



Software-Defined WAN

Andrii Ovrashko
Systems Engineer

May 18th, 2016

The World Changed

30
Year
s!



1986: Cisco's 1st Router
Advanced Gateway Server [AGS]

Current State of the Network



Dispersed Geography

Organizations continue to spread out from large, centralized locations to multiple smaller, distributed locations.¹



Applications Proliferation

56% of organizations currently deploy some application delivery optimization tools to deal with bandwidth growth and streaming videos.¹



Continued Device Explosion

By 2019, there will be 24 billion networked devices and connections, up from 14 billion in 2014.²



More Bandwidth Required

Business IP traffic will grow at 20% CAGR from 2014 to 2019.²



Mobility

80% of customer-facing employees are served at the branch.³

Sources:

1. WAN Key Trends, Nemertes Research 2015. DN4391.
2. State of the WAN Report, 2015. Webtorials.
3. US Census Bureau of the U.S. Department of Commerce, 2015.

WAN Evolution

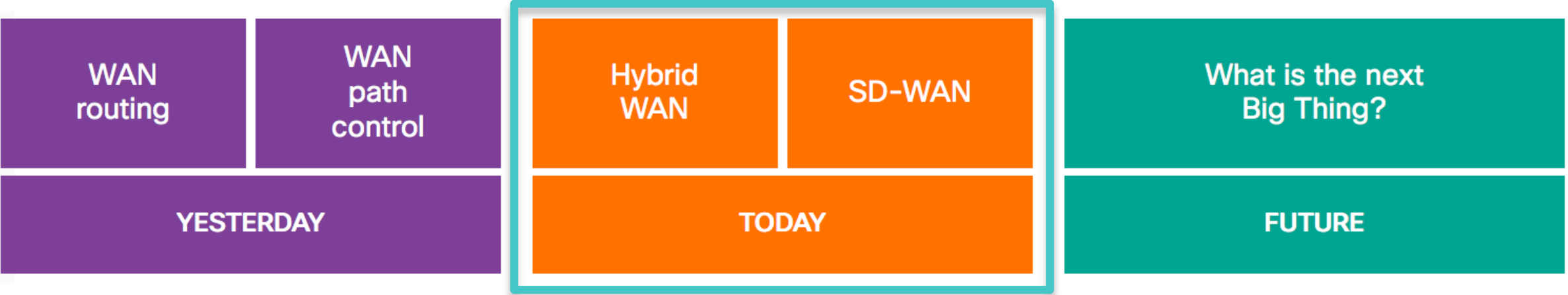

SD-WAN addresses some facets of today's IT challenges: simplicity, openness, and agility.

Why SDN?

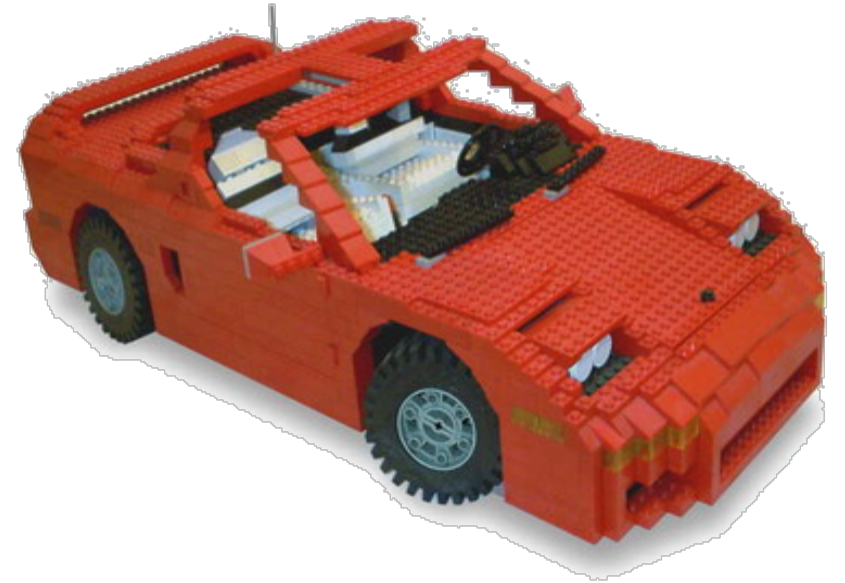
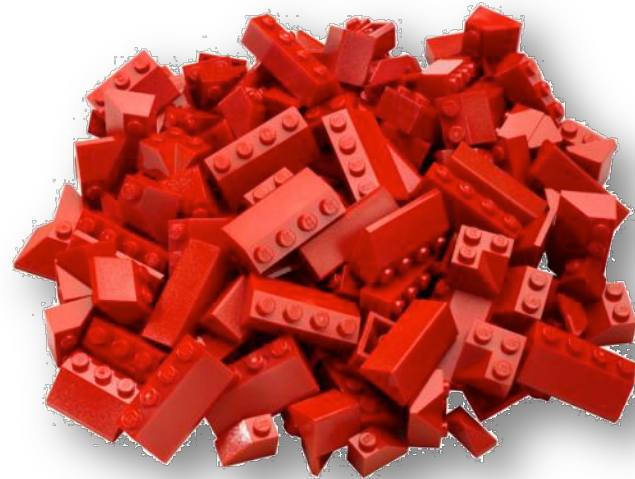

Why Adopt SD-WAN?

IT Capabilities

Increase flexibility¹

Simplify IT operations¹

Achieve rapid, elastic deployments¹

Business Outcomes

Cost reduction

Business agility

Faster time to market

Source:

1. State of the WAN Report, 2015. Webtorials.

What's Holding Back SD-WAN Adoption?



Immature products/solutions¹



Unproven implementation¹



Lack of ROI



Lack of mainstream deployments



Lack of partner support and solutions



Weak security

Source:

1. [State of the WAN Report, 2015](#). Webtorials.

SD-WAN Is One Approach to Solving Today's WAN Challenges

Simple

Automated tools to simplify IT operations

Open

Extensible and interoperable interfaces for customization

Agile

Policy-based system automation

Cisco Intelligent WAN (IWAN) = That Next-Generation Architecture

Simple

Agile

Open

Secure

Proven

Supported

IWAN Has the Key Technology Pillars to Enable Digital Transformation

Openness & Automation

Policy-based system management: WAN, access, data center

IWAN app with APIC-EM, Cisco Prime™ Infrastructure, Cisco Meraki®, Glue Networks, LiveAction

Network Innovations

Broadest scalable HW and SW portfolio and flexible deployment models

Routers, switches, security, unified communications and collaboration for branch, campus, and data center

Integrated Threat Defense

End-to-end security: At the perimeter, endpoint devices, and in the cloud

Web, cloud, zone-based firewall, intrusion prevention and detection systems

Application Experience

Intelligent path control with application visibility and optimization

Application Visibility and Control, NBAR2, PfRv3, WAAS, Akamai (SaaS)

Proven Implementation

Market leadership, broad partner ecosystem and services with 24x7 global support

SP (IWAN as a service), enterprises, small and midsize businesses

Cisco ONE: Investment Protection & Scale-as-You-Grow Model

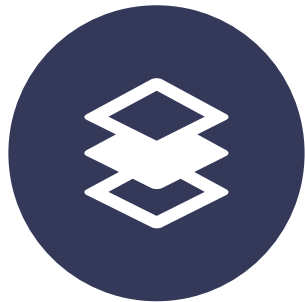

**Simple Set
of Solutions**



**Access to
Innovation**



**License
Flexibility**

Cisco Digital Network Architecture

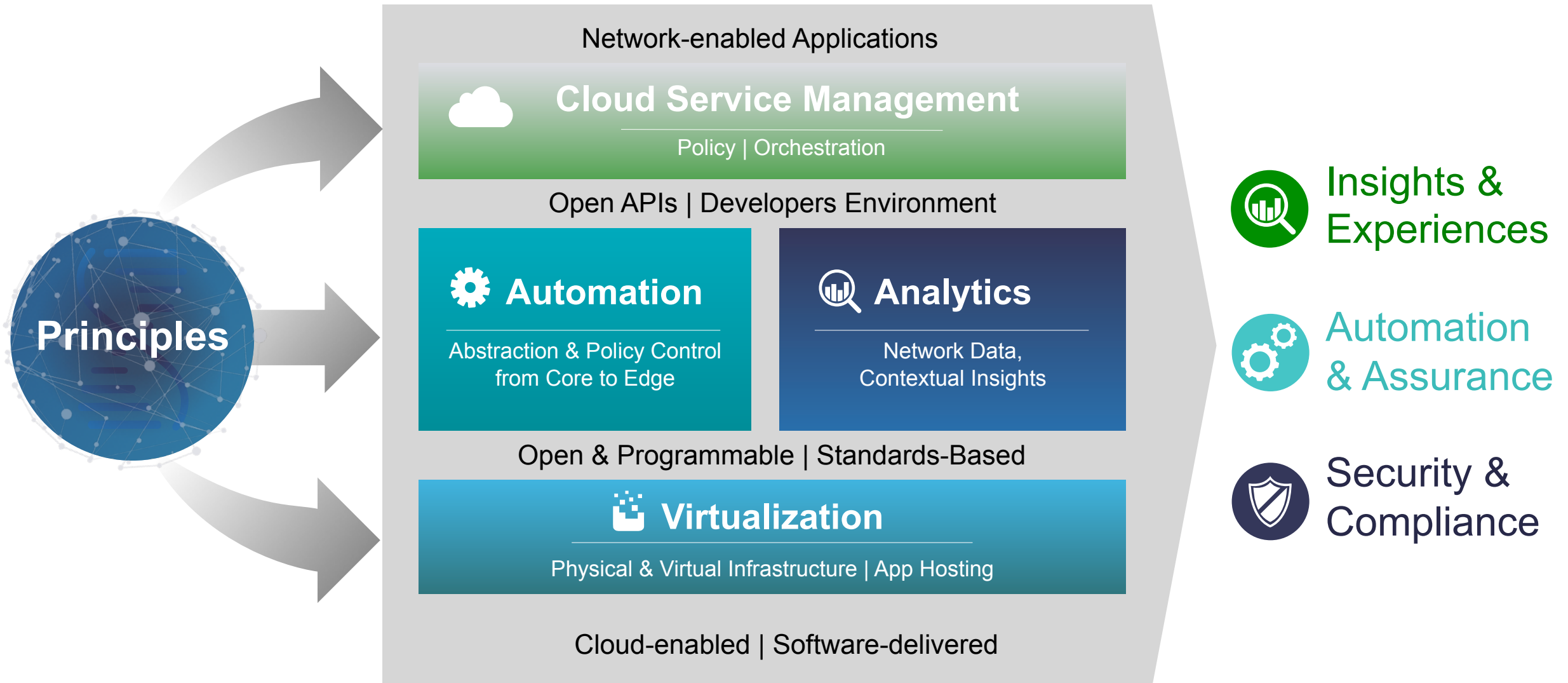

Why Move to Internet as WAN?

Low-Cost Alternative

46%

of Organizations
Are Planning to
Transition to
Internet
Connections

Internet Pricing vs. Reliability, 1998-2012

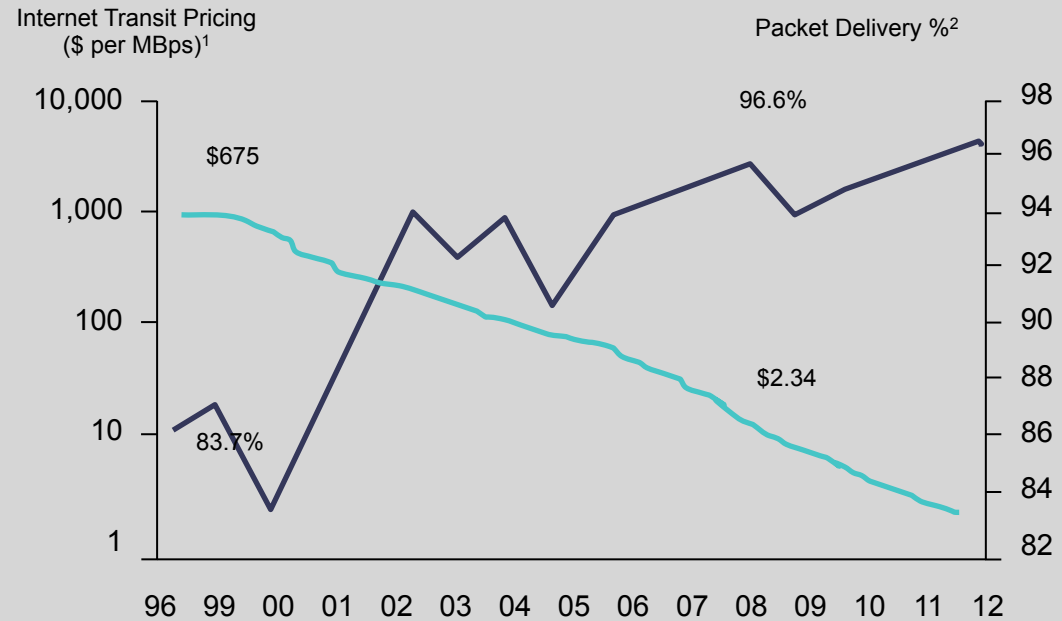

Requirements for Technology Assessment

Management

- ✓ To what extent does the solution support northbound API for third-party management or control applications?

Security

- ✓ How is direct Internet access (DIA) supported, and which security services does the solution offer or integrate with?

iWAN

компоненты архитектуры

Intelligent WAN (iWAN) компоненты архитектуры

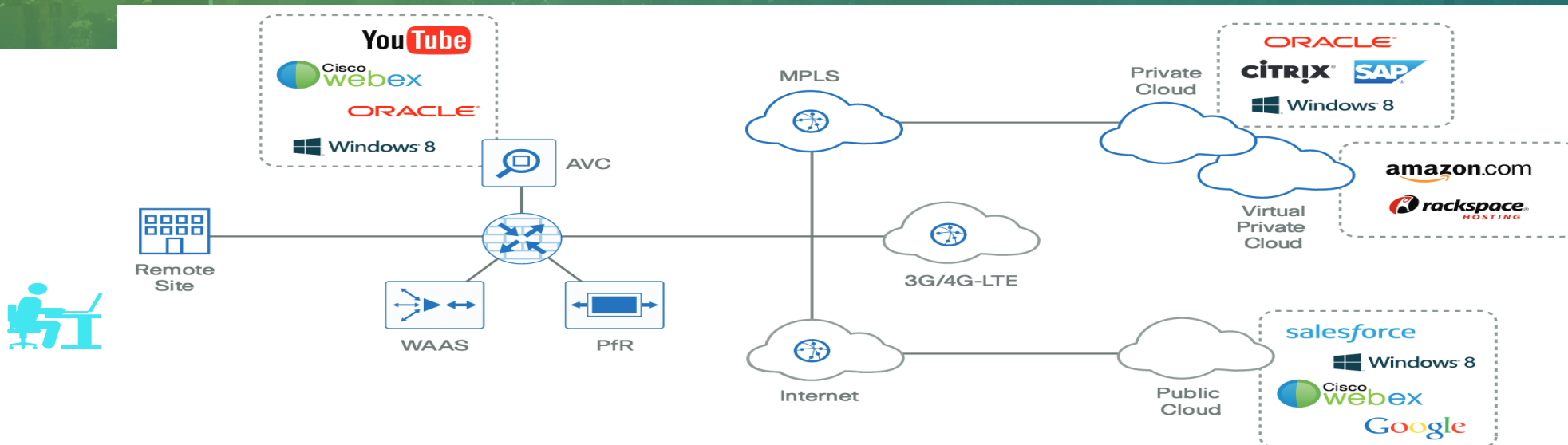

Prime
Infra



Автоматизация настройки & управления



Transport Independent

- DMVPN и IPSec
- Независимость от операторов
- Легкость смены типа каналов
- Упрощение, масштабирование



Intelligent Path Control

- PfRv3
- Маршрутизация на уровне классов приложений
- Учет качества работы приложений
- Выравнивание утилизации



Application Optimization

- AVC / WAAS / Akamai
- Видимость приложений и анализ их производ-ти
- Ускорение приложений и уменьшение нагрузки на каналы



Secure Connectivity

- ZBFW, IPSec, CWS
- Snort IDS
- Защита от угроз ИБ

Значение отказоустойчивости по устройствам и каналам

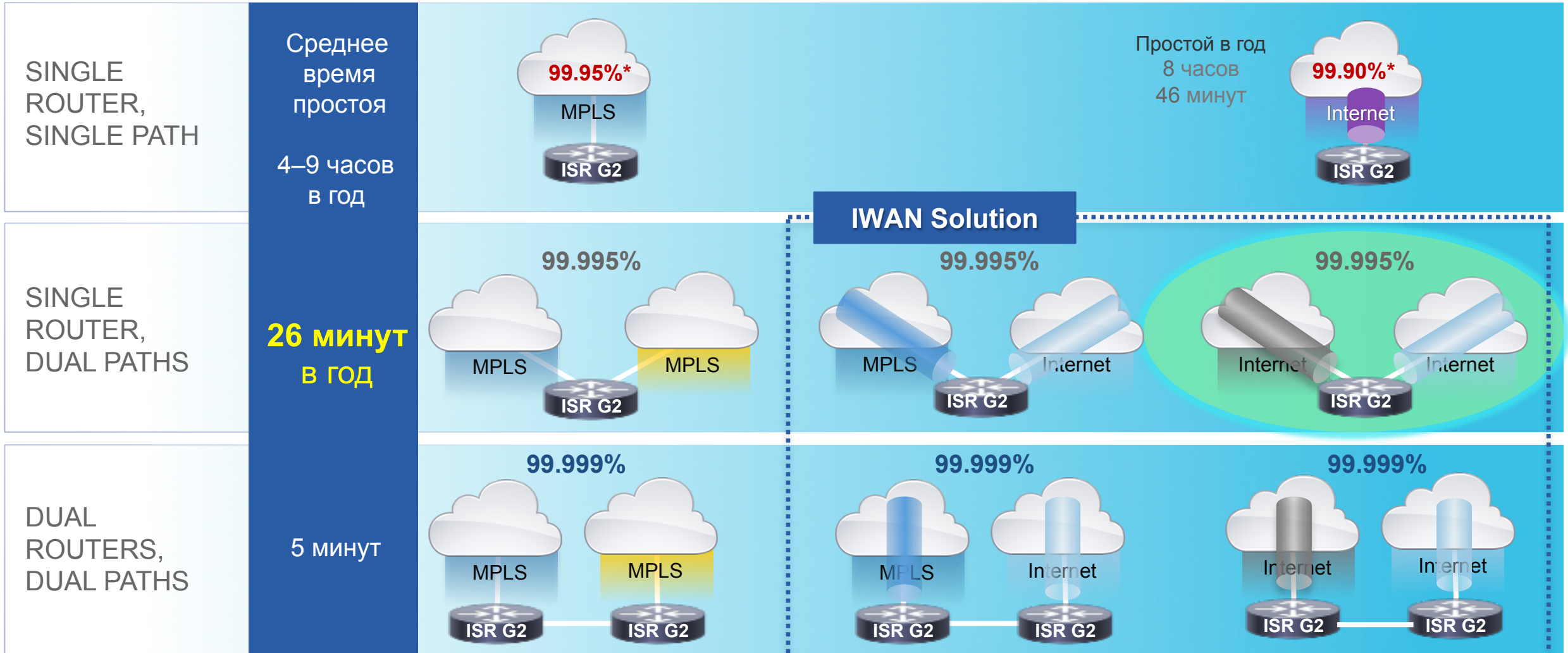
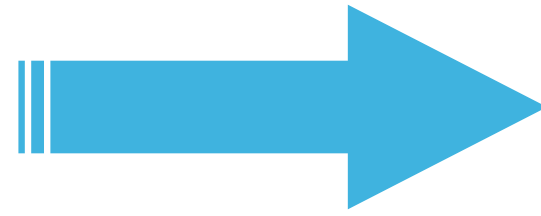

* Typical MPLS and Business Grade Broadband Availability SLAs and Downtime per Year, calculated with Cisco AS DAAP tool.

Cisco Intelligent WAN

- ✓ Удобный
- ✓ Доступный **SDN подход для WAN**
- ✓ Полезный

□ Провайдернезависимость

- PfRv3/FD-VRF: **Dual Path**
- **Cisco Validated Design**

□ Оптимальная утилизация каналов

- AVC+WAAS+Akamai: **App Centric**
- PfRv3+SDN: **Intelligent Path Control**

□ Простота настройки и управления

- PfRv3: Hub only configuration
- Единый домен маршрутизации
- Единое облако DMVPN
- **Сценарии настройки в APIC-EM**

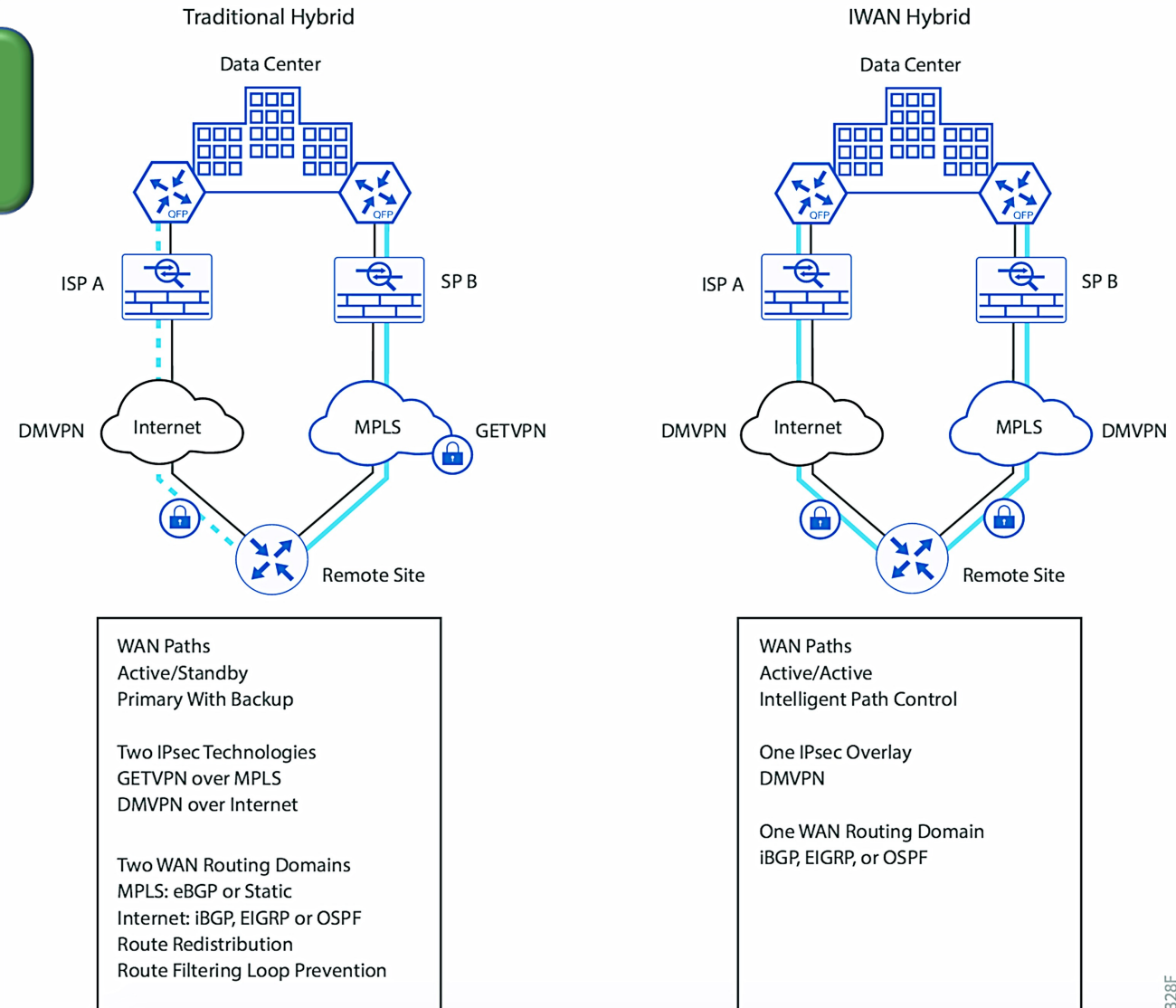

Cisco IWAN Technical Benefits

Cisco IWAN is certified by Open Networking User Group



Ten Requirements

Active-Active Architecture

Physical or Virtual Devices

Dynamic Traffic Engineering

Application Visibility, Prioritization and Steering

HA and Resilient Hybrid WAN

L2/3 Interoperability

Management Dashboard

Open North-bound API

Zero Touch Deployment

FIPS 140-2 with Certificate Management

Cisco IWAN is certified by Open Networking User Group



Ten Requirements

Active-Active Architecture

Physical or Virtual Devices

Dynamic Traffic Engineering

Application Visibility, Prioritization and Steering

HA and Resilient Hybrid WAN

L2/3 Interoperability

Management Dashboard

Open North-bound API

Zero Touch Deployment

FIPS 140-2 with Certificate Management

Application Aware Routing (PfR)

Intelligent Path
Control with Active-
Active Paths

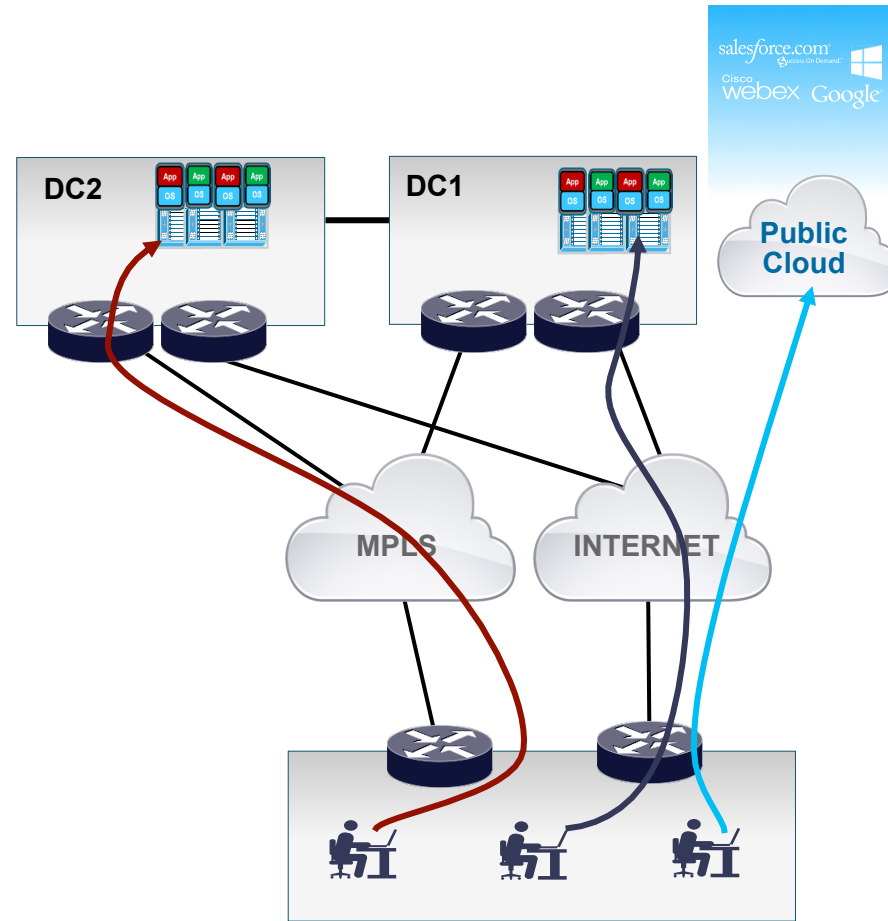

SD-WAN Automation

PfR Enterprise Domain Controller

Automated Discovery, Service Exchange, Peering & Coordination across the WAN Domain

Learning

Network Discovers the Apps (NBAR2) or based on DSCP

Network Discovers site topology, connected networks and prefix ownership

Passive Monitoring

Collect Application Performance

Using Unified Performance Monitors (AVC Infrastructure)

Dynamic Probing

Smart Probes for discovery

Also used if there is no traffic

Remote Feedback

Performance measured on ingress on the remote site

Sends performance feedback to Peers

QoS Synthesis

WAN Edge peers, learns link performance (per DSCP),

Manages congestion (local CAC, Remote CAC*)

How PfR Route Control Works

Key Operations

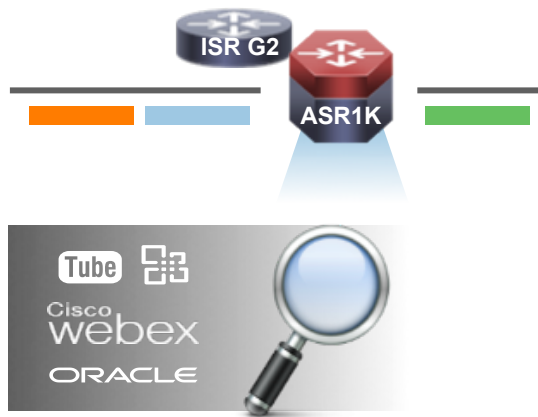

Define Your Traffic Policy

Identify Traffic Classes based on Applications or Transport Classifiers

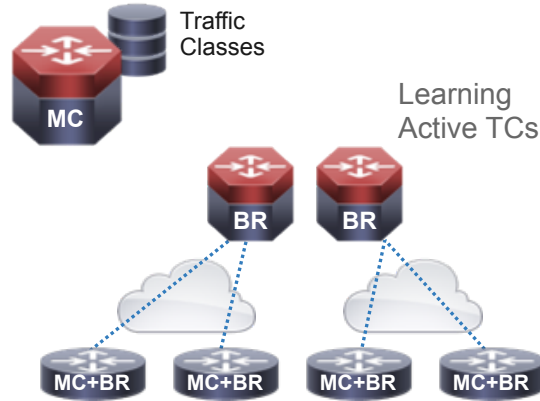

Learn the Traffic

ISR G2 and ASR Learn traffic classes flowing through Border Routers (BRs) based on your policy definitions

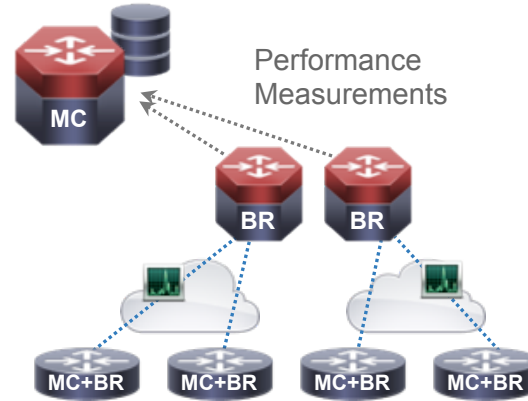

Measurement

Measure the traffic flow and network performance actively or passively and report metrics to the Master Controller

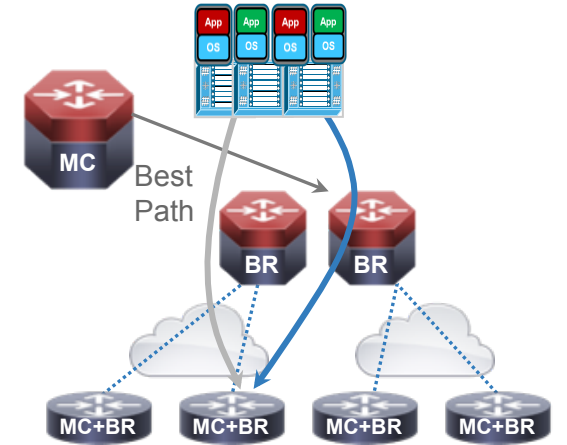

Path Enforcement

Master Controller commands path changes based on your traffic policy definitions

Securing IWAN Transports with Front-door VRF

Isolation of external networks

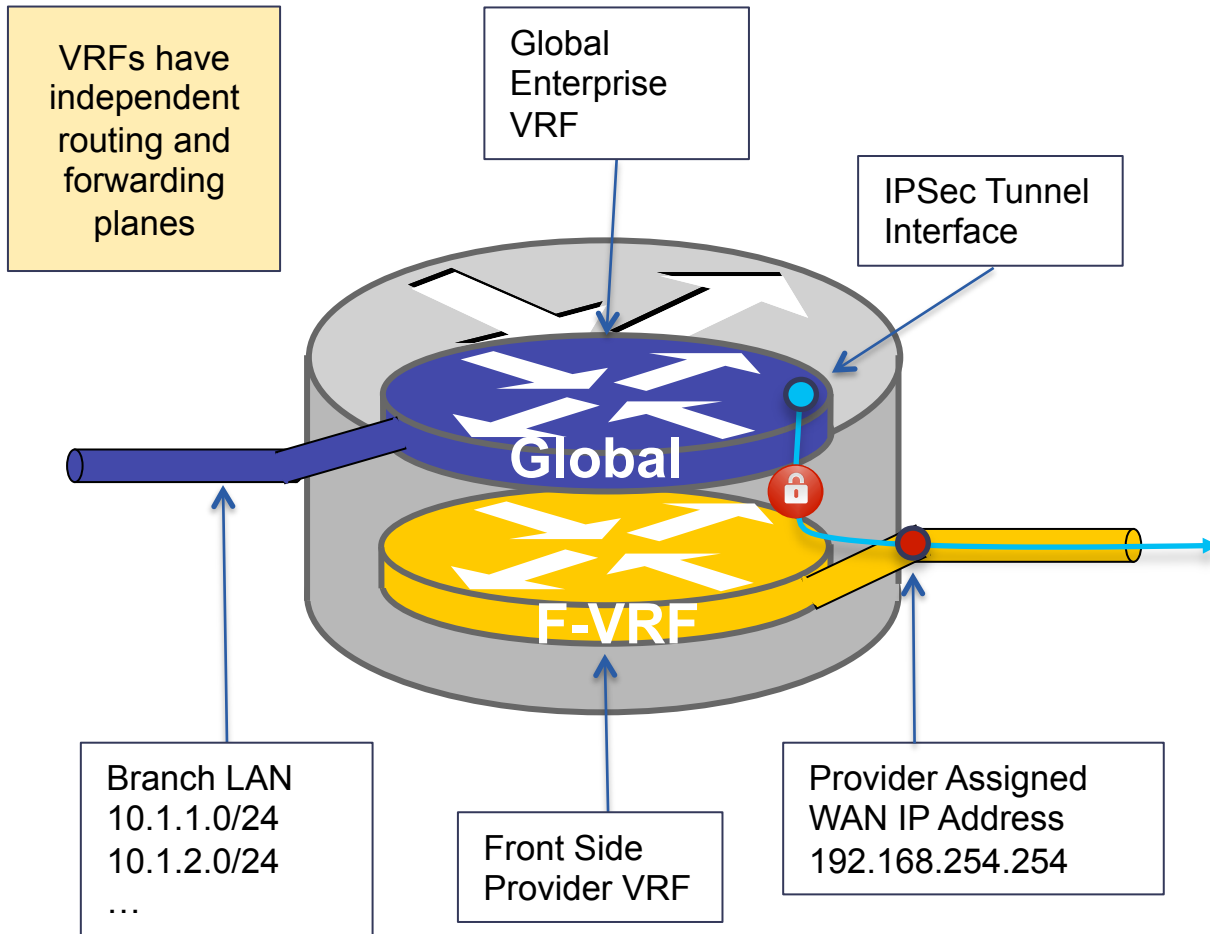

- Virtual Route Forwarding (VRFs) create multiple logical routers on a single device
 - Separate control/forwarding planes per VRF
 - No connectivity between VRFs by default
 - Provider side VRF (yellow) for external networks, Global VRF (blue) for internal networks
- Provider VRF minimizes threat exposure
 - Default routing only in Provider VRF
 - Provider assigned IP addressing hides internal network
 - Provider IP address used as IPsec tunnel source
 - Only IPsec allowed between internal Global and Provider Front Side VRFs

Add Application Classification and Control for IWAN

Group your traffic by application using NBAR2

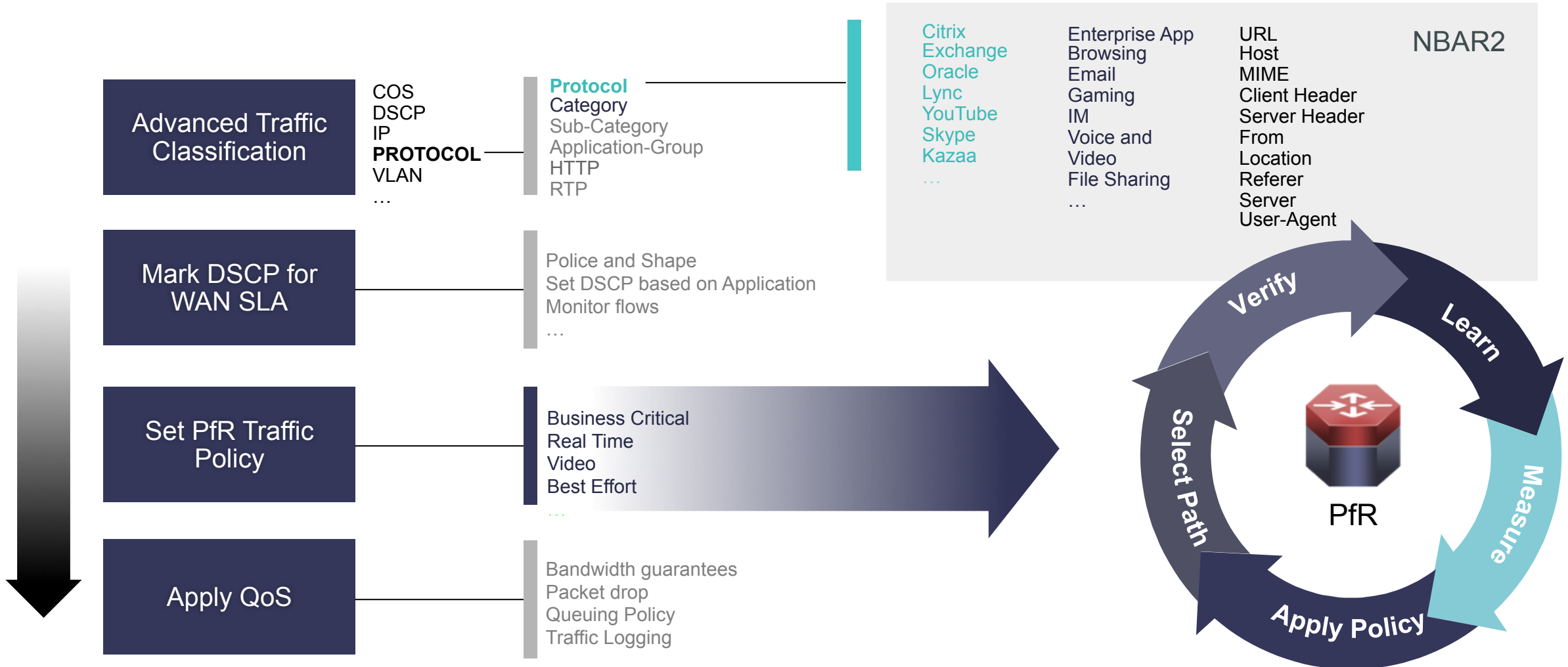

Application Recognition (NBAR w/ DPI)

What Applications, How Much Bandwidth, Flow Direction?
Application Response Time?
Voice and Video Performance?



What Difference Does AVC Make?

Top N Applications (no AVC)
Rate | Volume

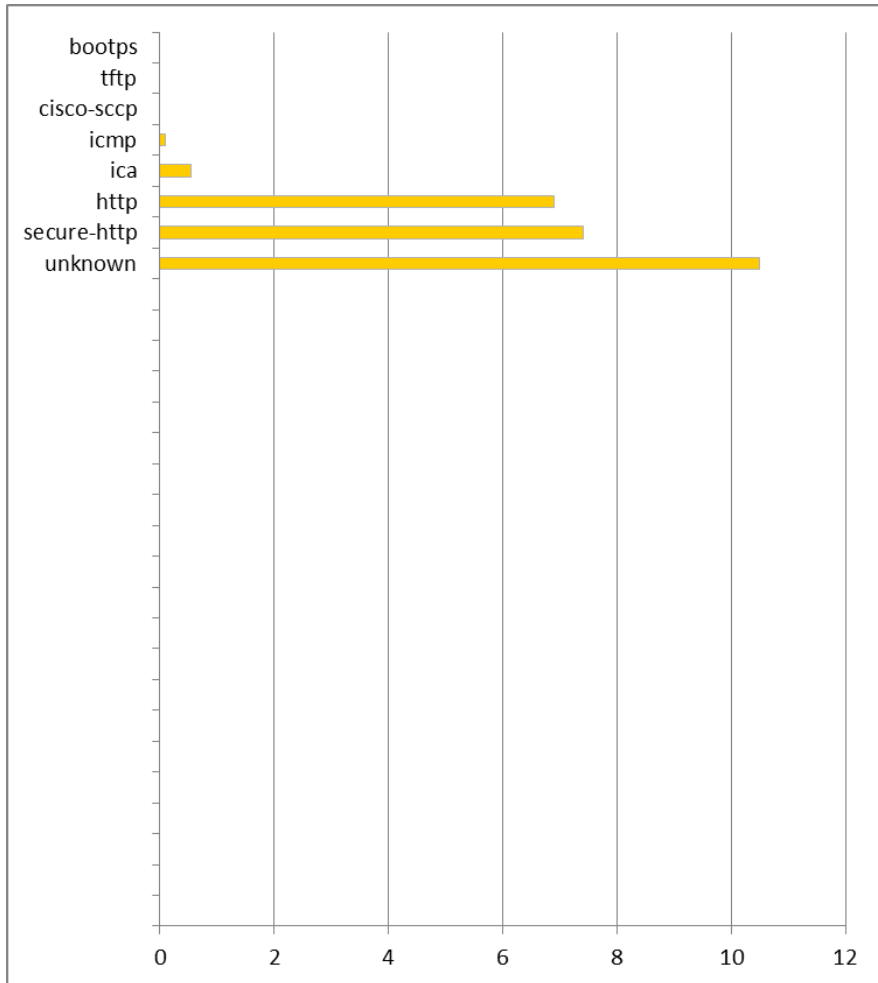

Traffic Wireless Wired ?



2013 March 12, 15:22:54 CET

Top N Applications (with AVC)
Rate | Volume

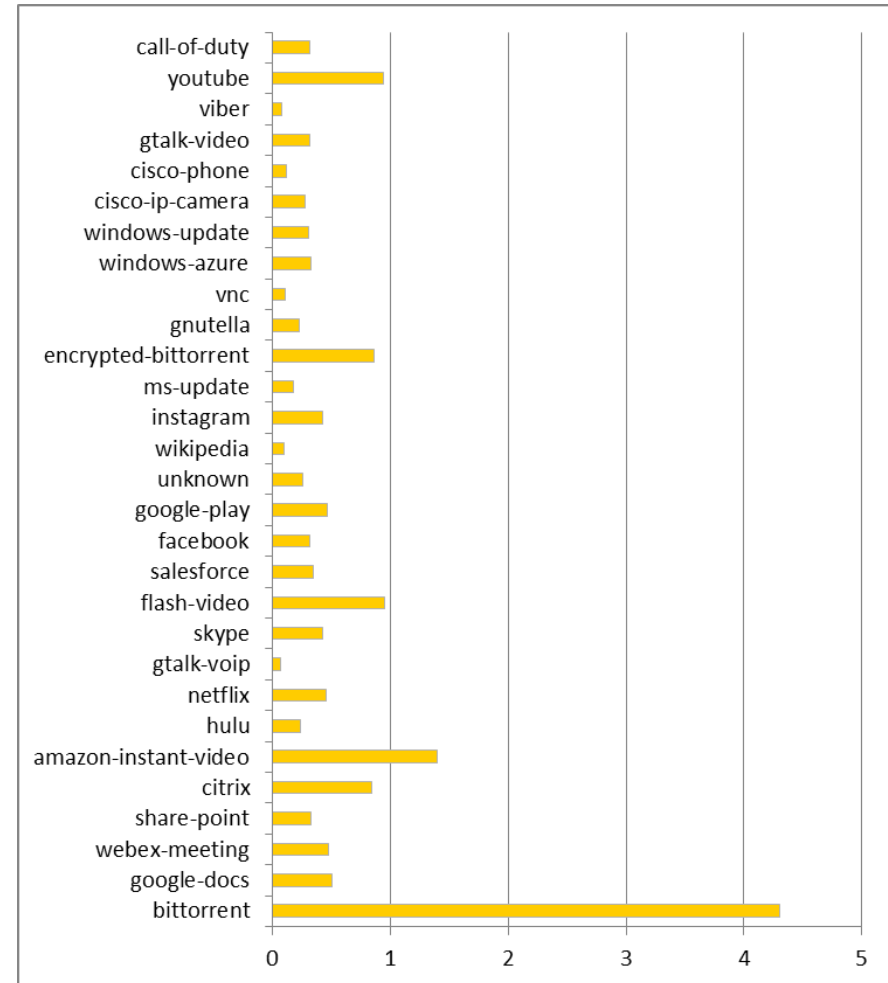

Traffic Wireless Wired ?



2013 March 12, 15:22:54 CET

Application Optimization (WAAS)



Email (5MB Attachment)

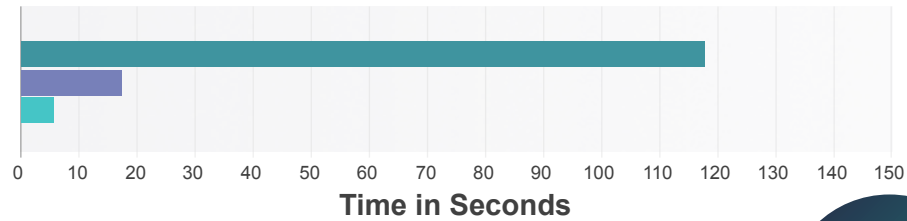

- Send and Receive Email over native WAN
- First Optimized with WAAS
- Second Pass Optimized with WAAS

**24x
Faster**



File Services (5MB File)

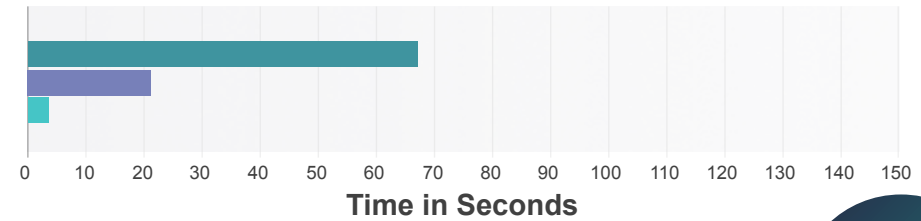

- File Drag and Drop Over native WAN
- First Optimized with WAAS
- Second Pass Optimized with WAAS

**17x
Faster**

Microsoft

SharePoint (5MB Document)

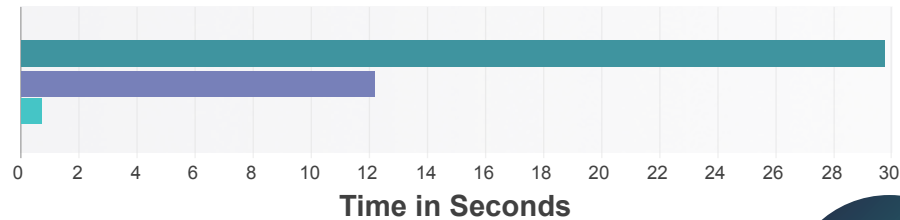

- Sharepoint File Download over Native WAN
- First Optimized with WAAS
- Second Pass Optimized with WAAS

**30x
Faster**

CITRIX® VDI (Citrix)

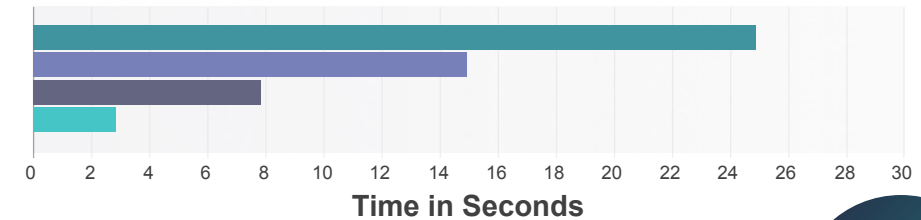

- Launch Citrix XenDesktop Over Native Citrix ICA/SSL
- Launch Citrix XenDesktop with WAAS
- Site Navigation Over Native Citrix ICA/SSL
- Site Navigation with WAAS

**3-8x
Faster**

Cisco WAAS Advanced Capabilities

Edge caching enhances the user experience

AKAMAI CONNECT **World's Best Optimization Solution for HTTP Traffic**

AKAMAI CACHING AND ACCELERATION

Transparent HTTP
Caching

Dynamic URL OTT
HTTP Caching

Akamai
Connected Cache

Content
Pre-positioning

CISCO WAAS

LZ
Compression

Data
De-duplication

TCP
Optimization

Application Specific
Acceleration

Now Supports

Akamai Cloud | Single-sided Optimization | Secure Direct Internet Access

HTTP/S Optimization (Akamai Connect)

Percentage Of Enterprise Network Traffic

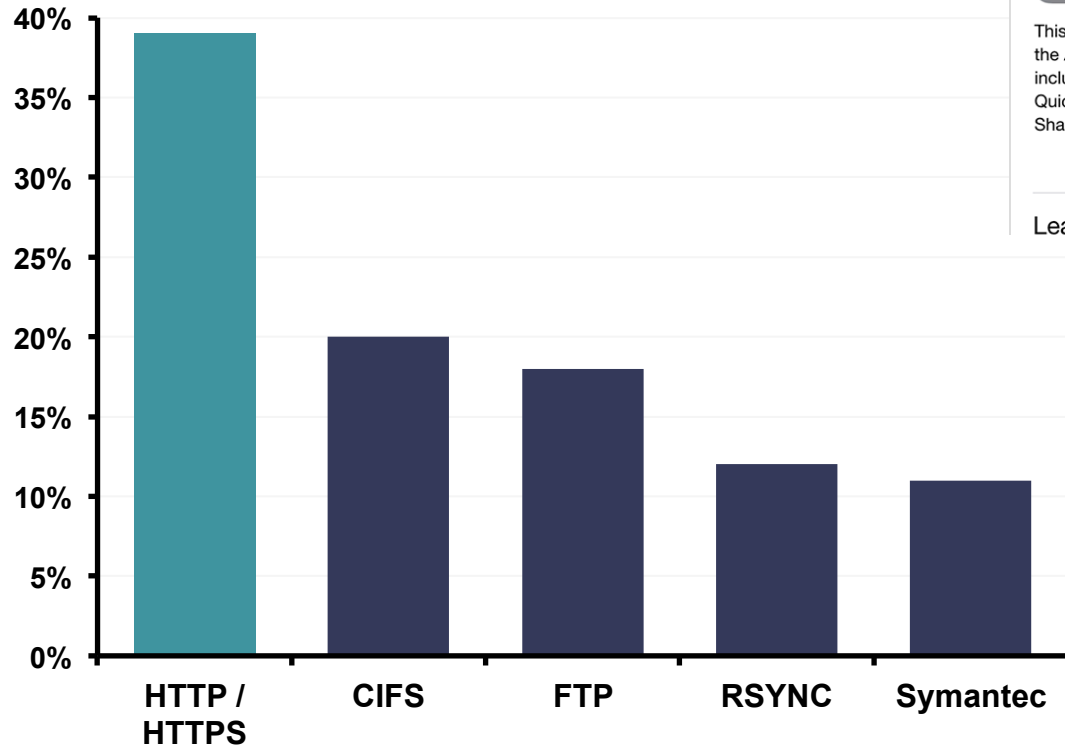

Windows Update

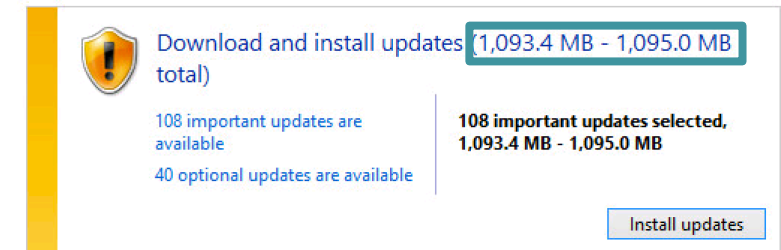

Akamai Connect
integrated into
Cisco ISR Routers

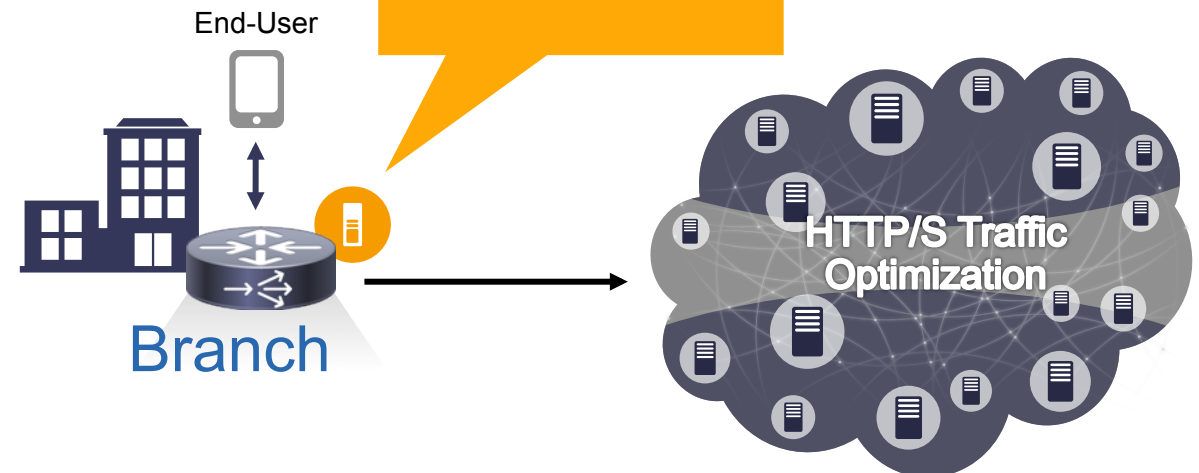

Industry Standard Application and Flow Export (Flexible NetFlow & IPFIX)

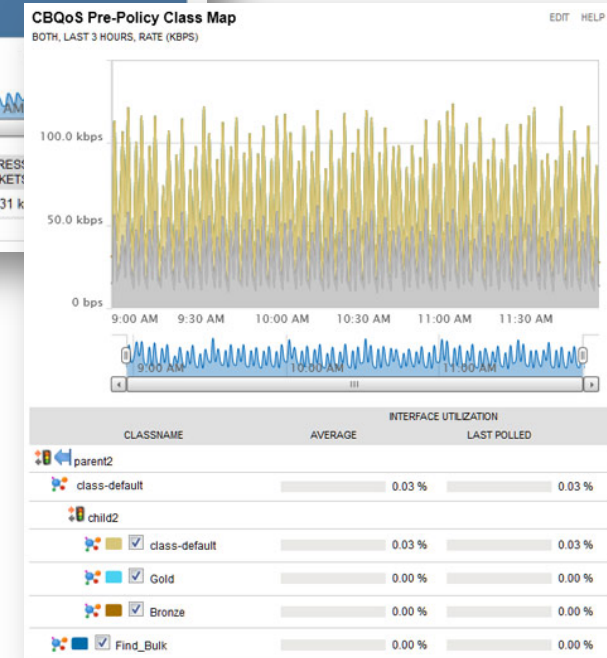
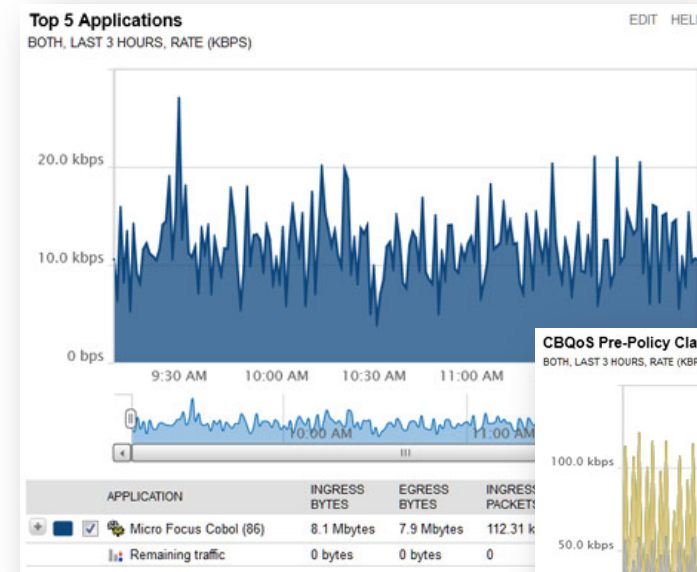
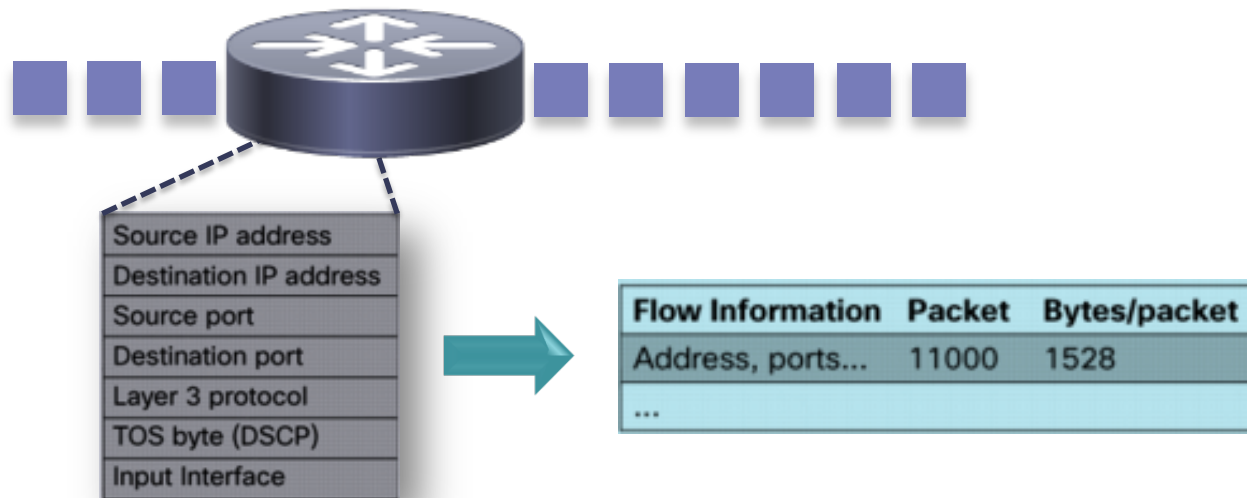

Image Signing & Secure Boot

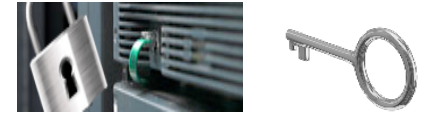

Image Signing

- Cryptographically signed images help ensure that the firmware, BIOSes, and other software are **authentic and unmodified**.
- These signatures provide a critical check so that **only authentic, unmodified software can be executed**.
- As the system boots, this signature is checked by an anchor of trust, ensuring the **integrity of the system's software**.

Secure Boot and Hardware Trust Anchors

- Secure Boot takes Image Signing to the next level by providing increased assurance about the **integrity of the hardware and software** that are performing image checks and other critical system functions.
- It does this through a combination of immutable hardware-based anchors of trust and it assures that a **system's foundational state and software that is to be loaded is unable to be modified** (regardless of a user's privilege level).

Supported in both ISR 4K and ASR 1K (1001/2-X) Platforms

Identity Aware Security (TrustSec)

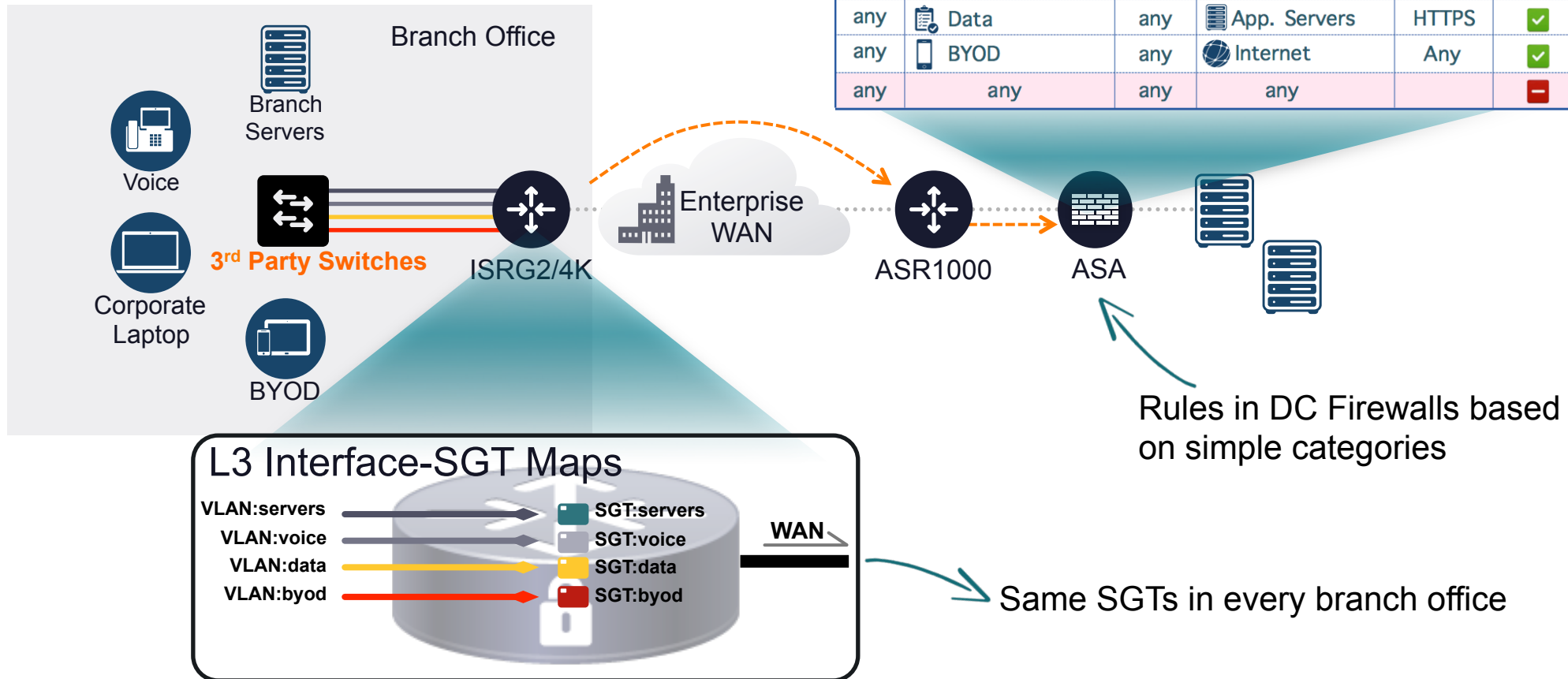

Identity Aware Security (TrustSec)

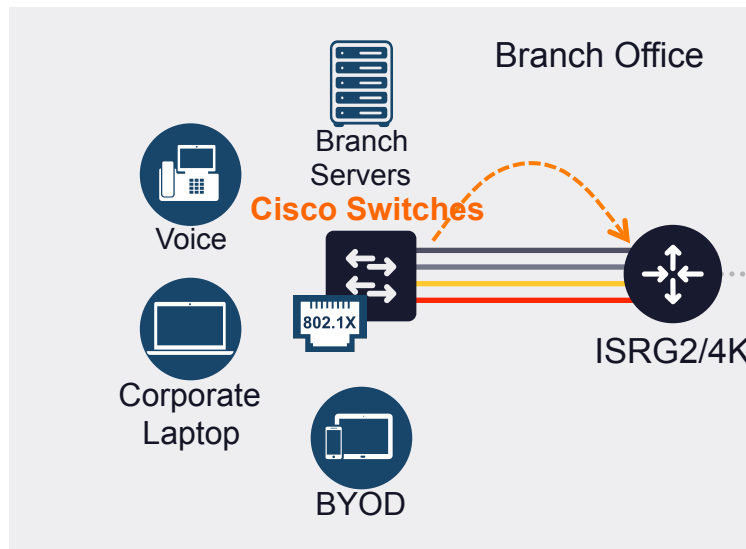

| Source Criteria: | | Destination Criteria: | | Service | Action |
|------------------|-----------|-----------------------|-----------------|---------|--------|
| IP | SGT | IP | SGT | | |
| any | Servers | any | Database | HTTPS | ✓ |
| any | Voice | any | Comm Services | HTTPS | ✓ |
| any | Data | any | App. Servers | HTTPS | ✓ |
| any | BYOD | any | Internet | Any | ✓ |
| any | Employee | any | App Servers | HTTPS | ✓ |
| any | Suppliers | any | Shared Services | HTTPS | ✓ |
| any | any | any | any | | ✗ |



Coarse-grained roles from VLAN mappings AND Fine-grained roles from authentication

802.1X Policy

| Status | Rule | Condition | SGT |
|--------|----------------------|-------------------------------|------------------------|
| ✓ | Non-Compliant | If Posture != compliant | ✗ Non-Compliant |
| ✓ | Employee | If AD:Group == employee | 👤 Employee |
| ✓ | Suppliers | If AD:Group == ext-contractor | 👥 Suppliers |
| ✓ | IP Phones | If DeviceType == Cisco Phone | 📞 Voice |
| ✓ | BYOD | If DeviceCert: Does not match | 📱 BYOD |

DNS Layer Protection (OpenDNS)

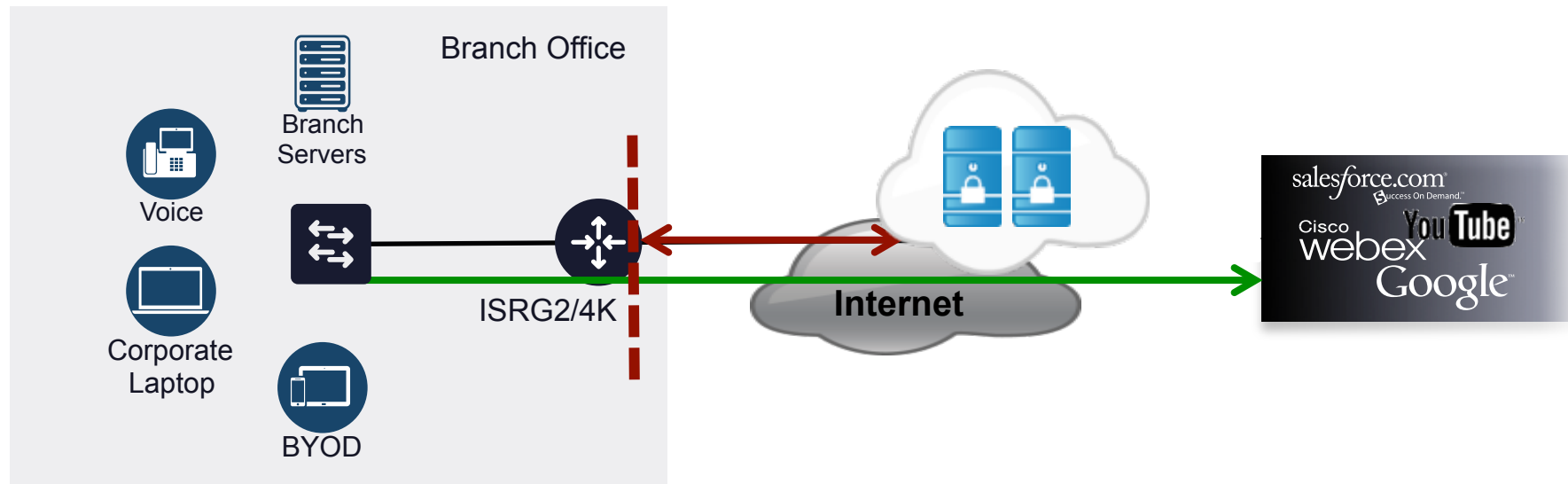

World's Broadest Service Offerings in One Box



IWAN Branch Services Routers

ISR4000 Series - IWAN AX Ready, Next Generation Branch

APPLIANCE LEVEL PERFORMANCE

- Service-Aware Dataplane
- Resilient Service Virtualization
- Multi-gigabit Fabric

APPLICATION CENTRIC

- App/User policy-driven deployment
- APIC_EM Automation: deploy in minutes
- Pay-as-you-grow
- Up-to-75% cost savings

INTEGRATED IWAN SERVICES

- IOS Firewall, VPN, IPSec, PfRV3, NBAR2, AVC, AppNav, VRF, MPLS
- Scalable on-chip service provisioning

ISR4451



1-2Gbps

ISR4431



500Mbps/1Gbps

ISR
4351



200/400Mbps

ISR 4331



100/300Mbps

ISR4321



50/100Mbps

IWAN Aggregation Border Routers

ASR1000 - IWAN AX ready, high performance routers

COMPACT, POWERFUL ROUTER

- Line-rate performance 2.5G to 200G+ with services enabled
- Crypto performance from 2G to 60G+
- Flexible I/O: SPAs and Ethernet LCs

BUSINESS-CRITICAL RESILIENCY

- Separate control and data planes
- Hardware and software redundancy
- In-service software upgrades

INTEGRATED IWAN SERVICES

- IOS Firewall, VPN, IPSec, PfRV3, NBAR2, AVC, AppNav, VRF, MPLS
- Scalable on-chip service provisioning

ASR1001-X



- 2.5G Upgradeable to 5G, 10G, 20G
- Up to 8G Crypto Throughput

ASR1002-X



- 5G Upgradeable to 10G, 20G, 36G
- Up to 4G Crypto Throughput

Modular ASR1006



- Modular, Redundant up to 200G
- Up to 60G Crypto Throughput

All Services Without “Killing” The Box

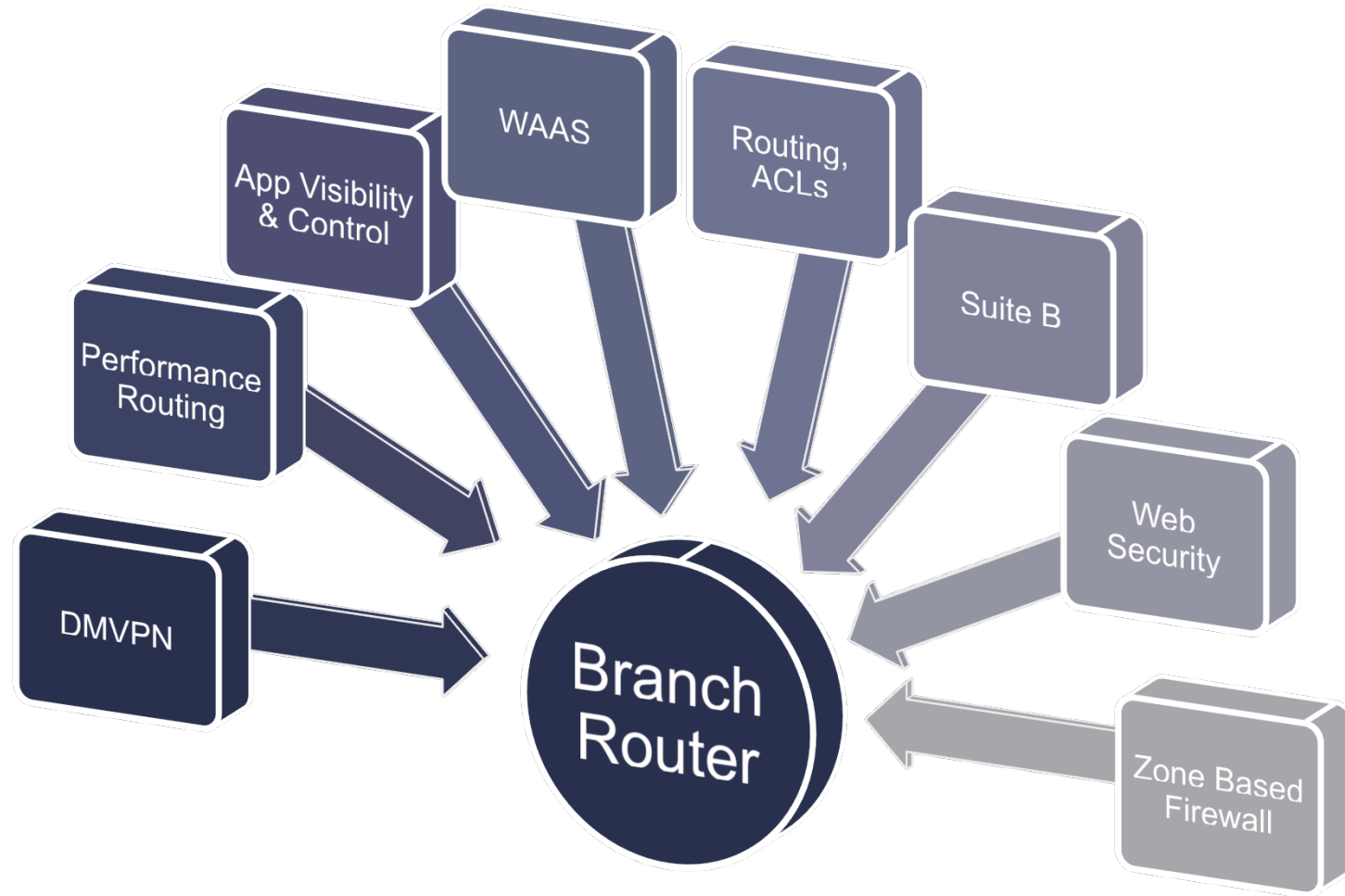

Unbeatable Investment Protection

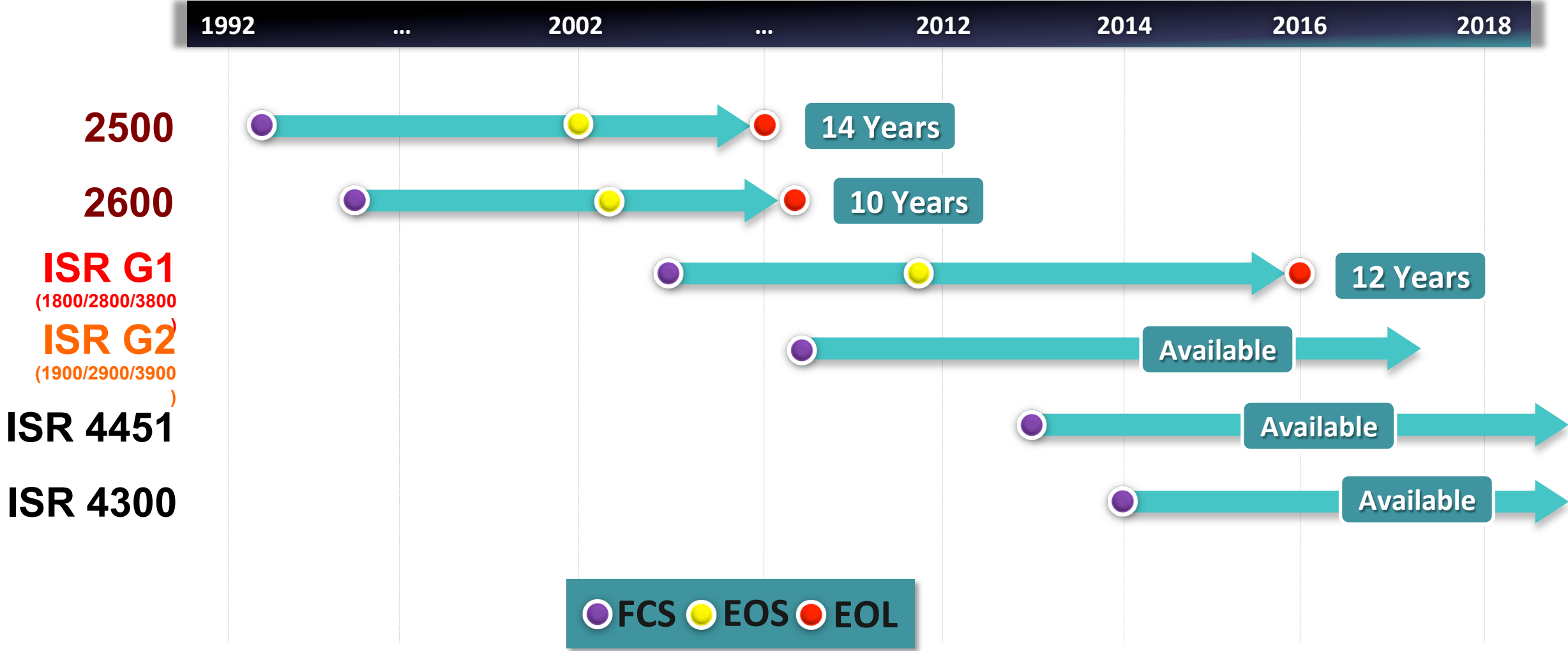

IWAN Management (APIC-EM + Prime Infra)

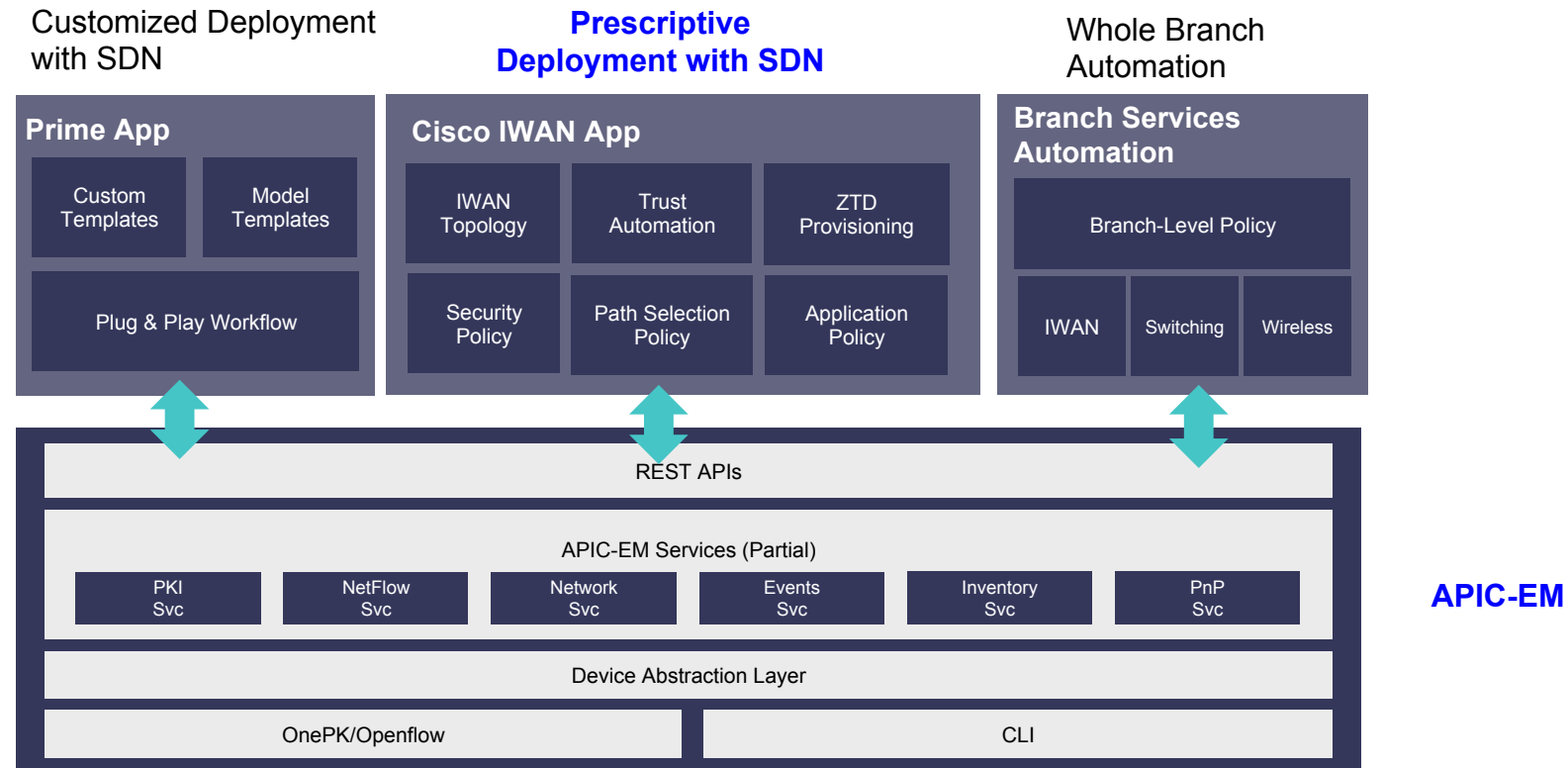

IWAN Management and Visualization



See
Visualize



Point
Troubleshoot,
Decision Making



Click
Control, Deploy



Fix
Improve

- An Application-aware Network Performance Management + QoS Control tool

- Fast, simple, cost effective way to monitor and control application performance leveraging Cisco capabilities

Flow



- End-to-End topology, flow and trace visualization
- Search capability
- Alert drilldown to applicable flows
- Point-and-click FnF configurations

QoS Monitor



- QoS dashboard and alert drill-down
- Pre and post-QoS graphs
- Congestion indicators
- Single-click QoS audit

QoS Configure

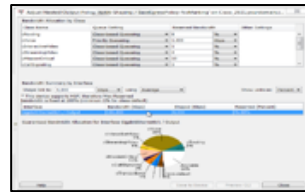

- QoS/ACL graphical configurator
- Customized policies with 25+ QoS templates
- Apply policy to multiple devices w/ single click
- CLI preview

LAN

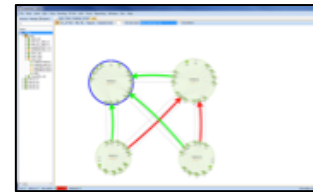

- LAN path and Spanning Tree connections
- Trunk and access bandwidth
- Layer 2 QoS stats
- VLAN filtering in topology view

Routing



- Topology view of active routes
- Graphical Policy Based Routing (PBR)
- Trace path to destination with return route
- Supports EIGRP, OSPF, IS-IS, BGP, RIP

IP SLA



- IP SLA topology view
- IP SLA dashboard
- Graphical IP SLA configurator
- Support all IP SLA tests including Video Operations

Key Deployment Topologies

Single DC/POP with Horizontal Scaling

- Multiple DMVPN Hubs per access network for redundancy and scaling
- Load balance or path preference option for Hub cluster
- If the current exit/channel to a remote site fails, converge over to an alternate exit/channel on the same (DMVPN1) network.
- Otherwise, converge over to the alternate (DMVPN2) network
- Scale – Distribute traffic/channels across multiple BRs/exits on a single (DMVPN)
- Utilize horizontal scaling for router capacity.
- Convergence across hubs/pops should only occur when all exits/channels in a hub/pop fail or reach max-bw limits.

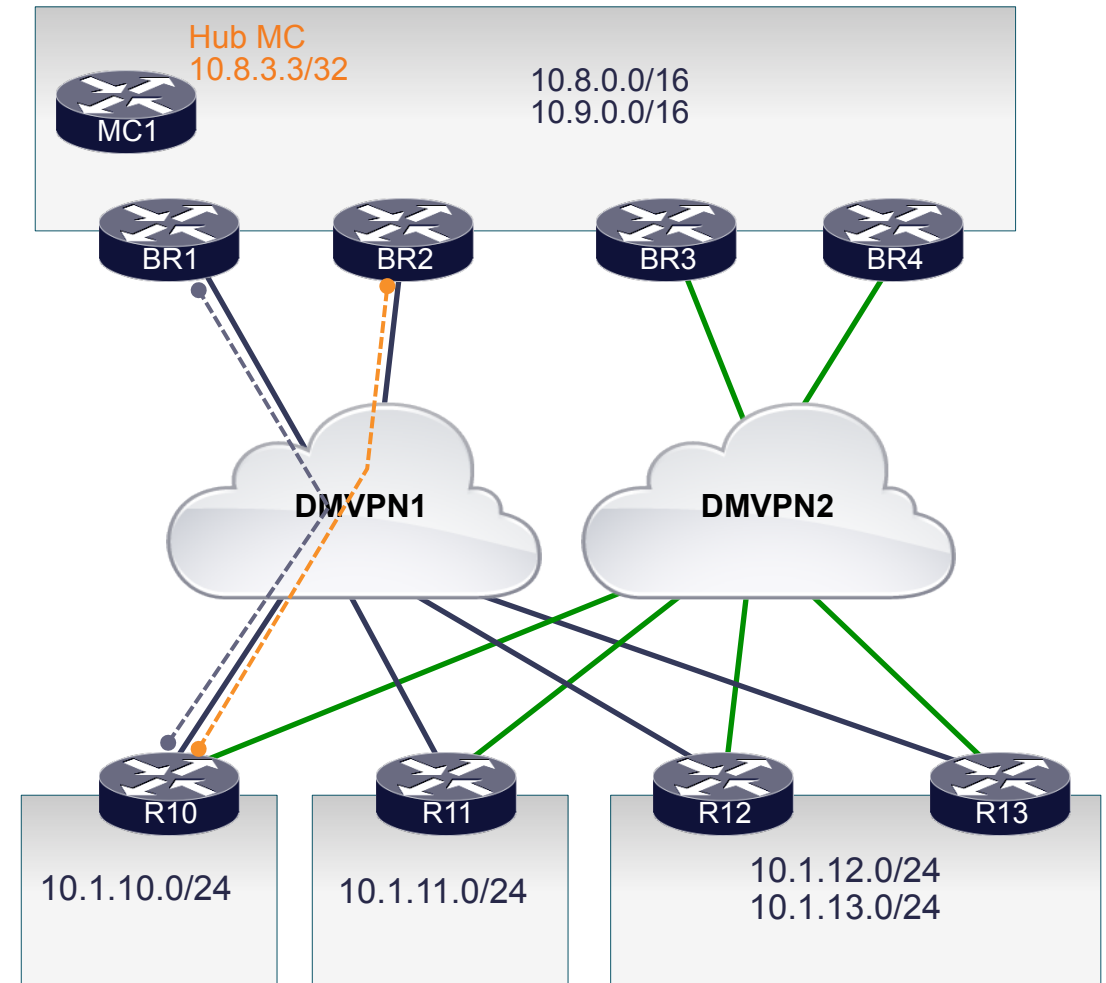

Multiple DCs with Dual POPs

- Dual DCs with DC backup link
- DCs collocate or separated from Access POPs
- Separate prefix advertised from each datacenters to spokes
- Single MC controlling all POP border routers
- PfR can redirect traffic through enterprise core to reach best egress point

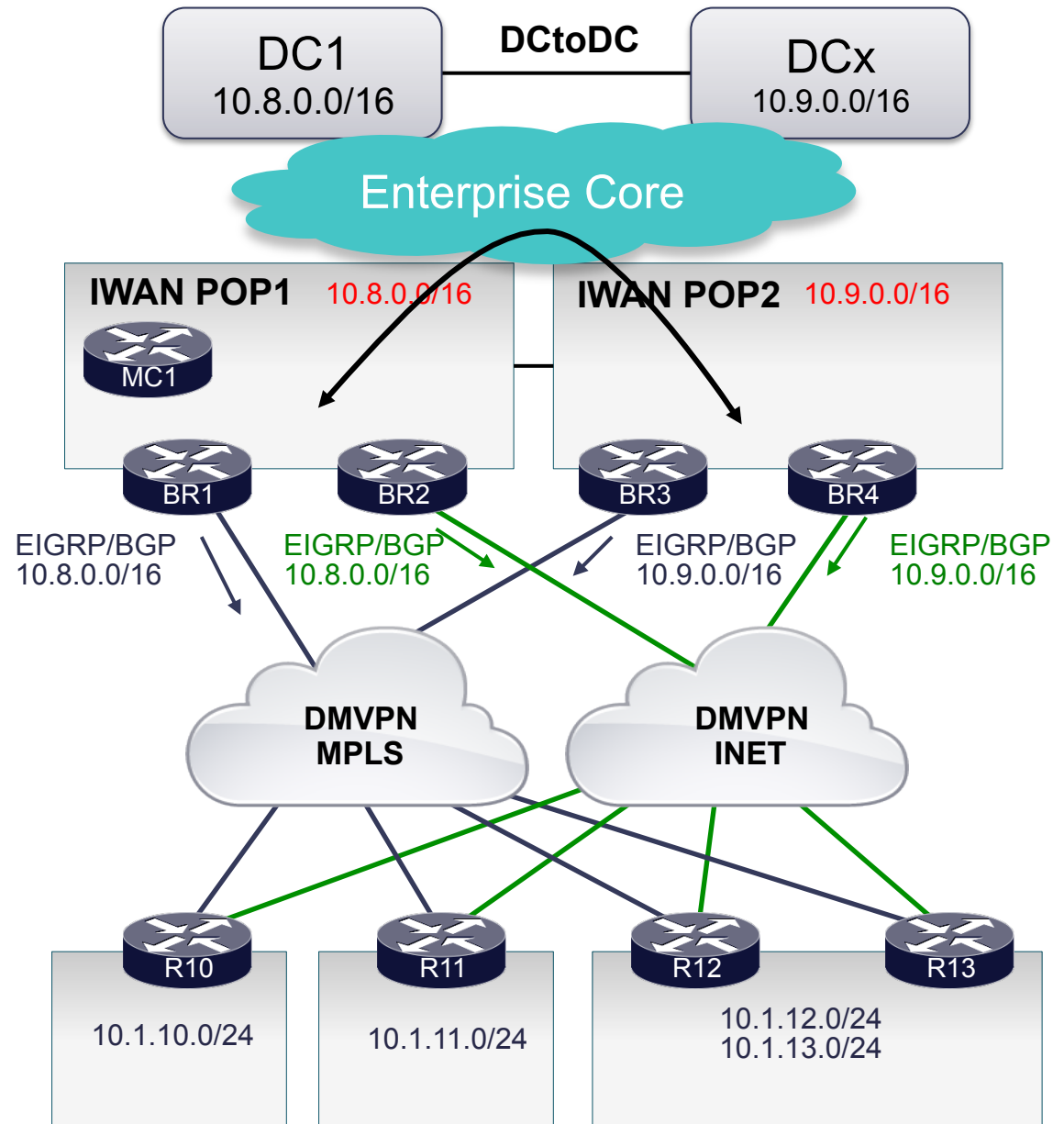

Multiple DCs with Scaling

- 2 POPs advertise the very same set of prefixes
- Datacenter may not be collocated with the POPs
- DCs/DMZs are reachable across the WAN Core for each PoP
- Branches can access any DC or DMZ across either POP(hub). And, DC/DMZs can reach any branch across multiple POPs (hubs).
- Multiple BRs per DMVPN per site may be required for crypto and bandwidth horizontal scaling

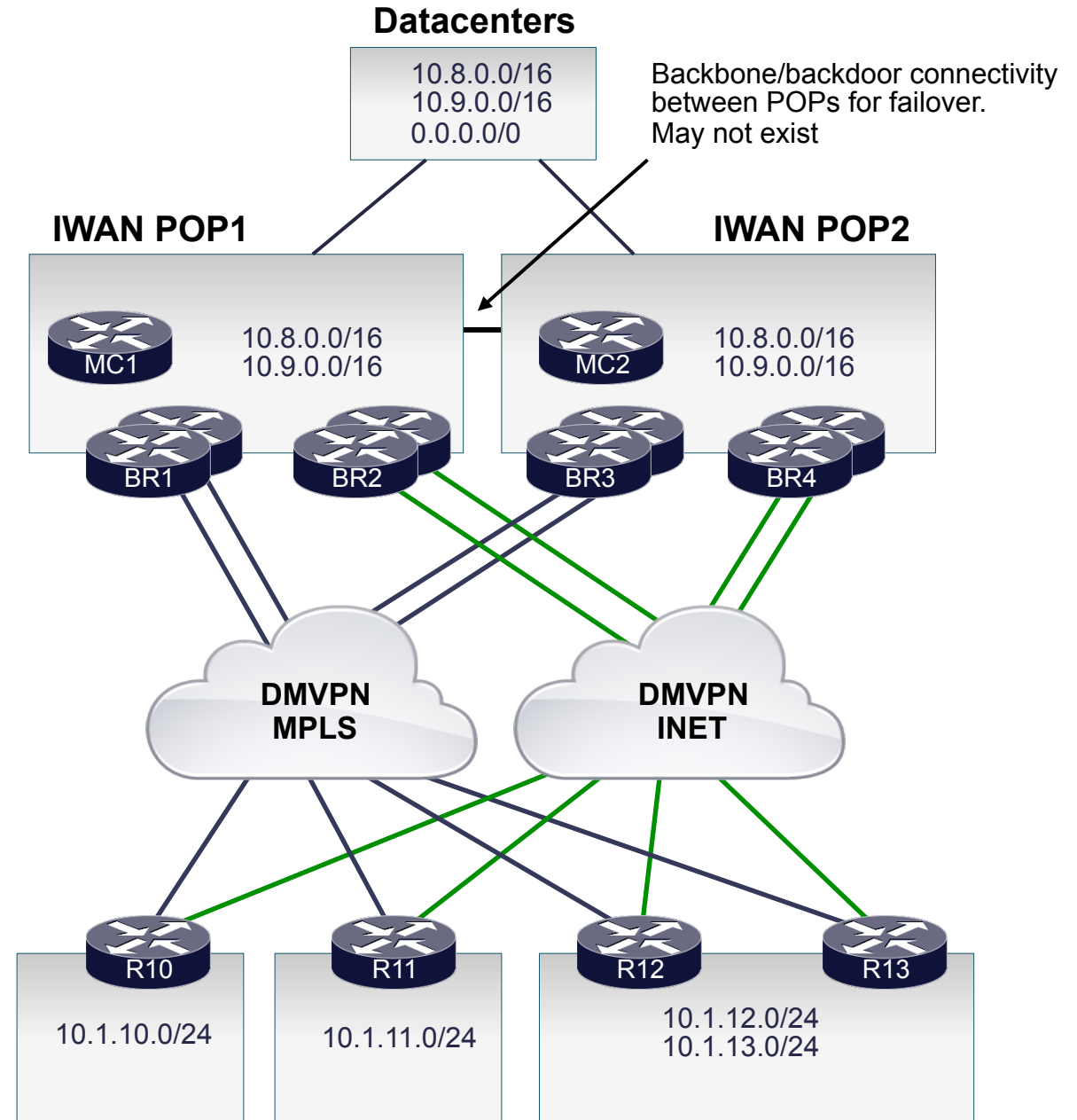

Home **Monitoring**

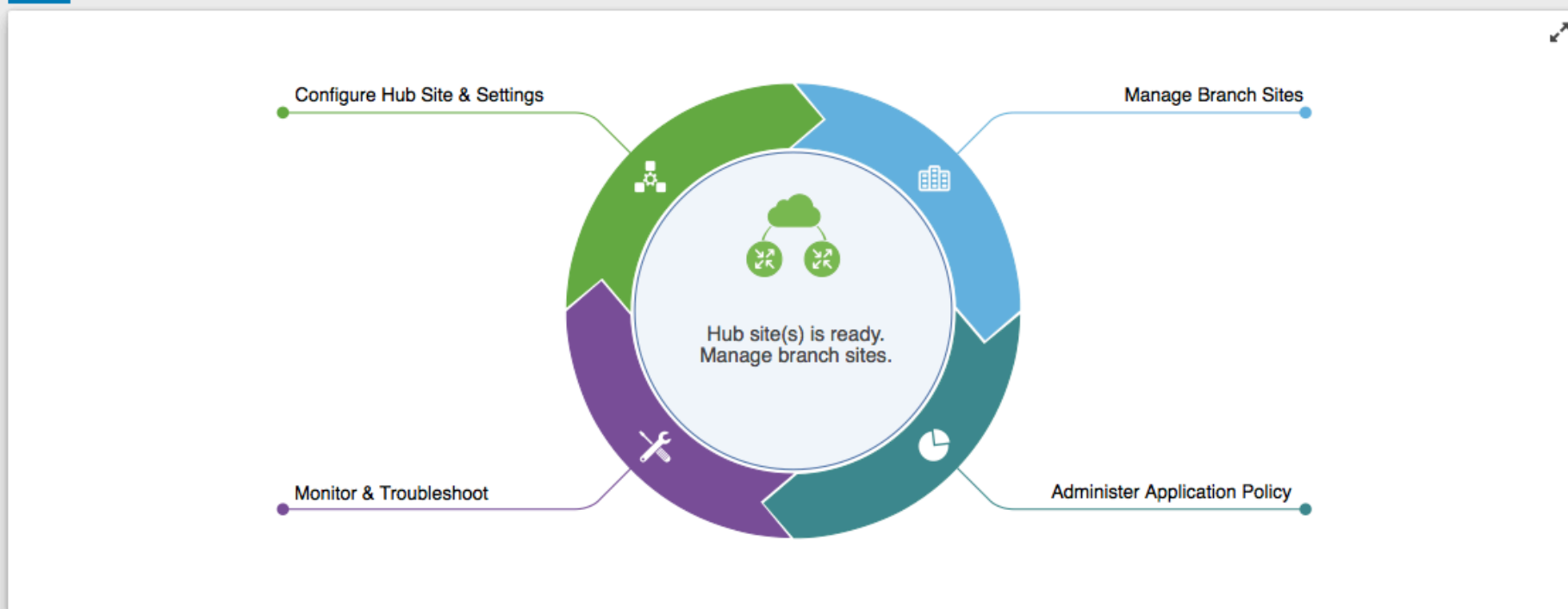

Site Dashboard

5 **Newly Discovered Devices**

12 **Sites**

1 In-Progress
2 Failed
9 Provisioned

1 **Scheduled Jobs**

0 Hubs
0 Branches
1 Application Policies

10 **Audit Logs**

Application Dashboard

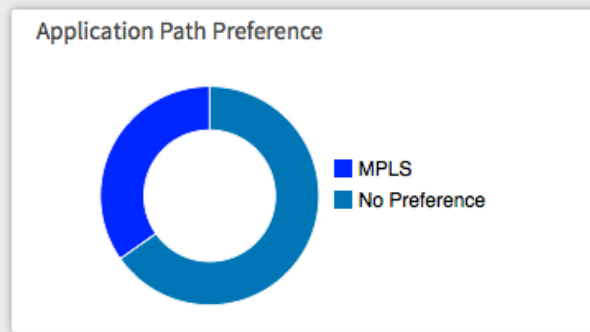
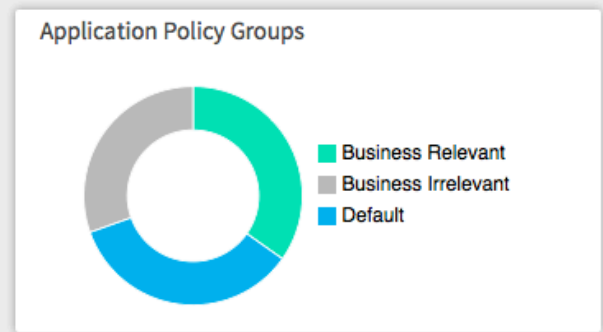
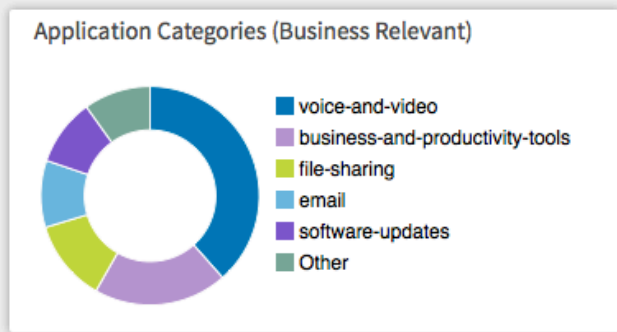

Provisioning Dashboard

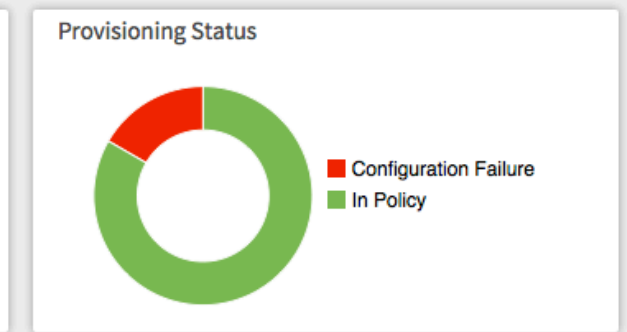

Network wide settings

- System
- IP Address Pools
- Service Providers
- IWAN aggregation site**
- Certified IOS releases

Apply Changes

Configure Hub Site

How many POPs/Datacenters do you have?

2

Pop 1: External MC Border Routers 2

Pop 2: External MC Border Routers 2

How many Providers do you have?

2

Connect the nodes based on your network topology

To connect any two nodes (Router & Cloud):

- Drag between nodes

To remove a link:

- Select a link by clicking on it. Pressing 'D' removes the selected link

To configure a Router or a link:

- Click on the Router
- Click on (+) icon over the link
- Enter the configuration and click save

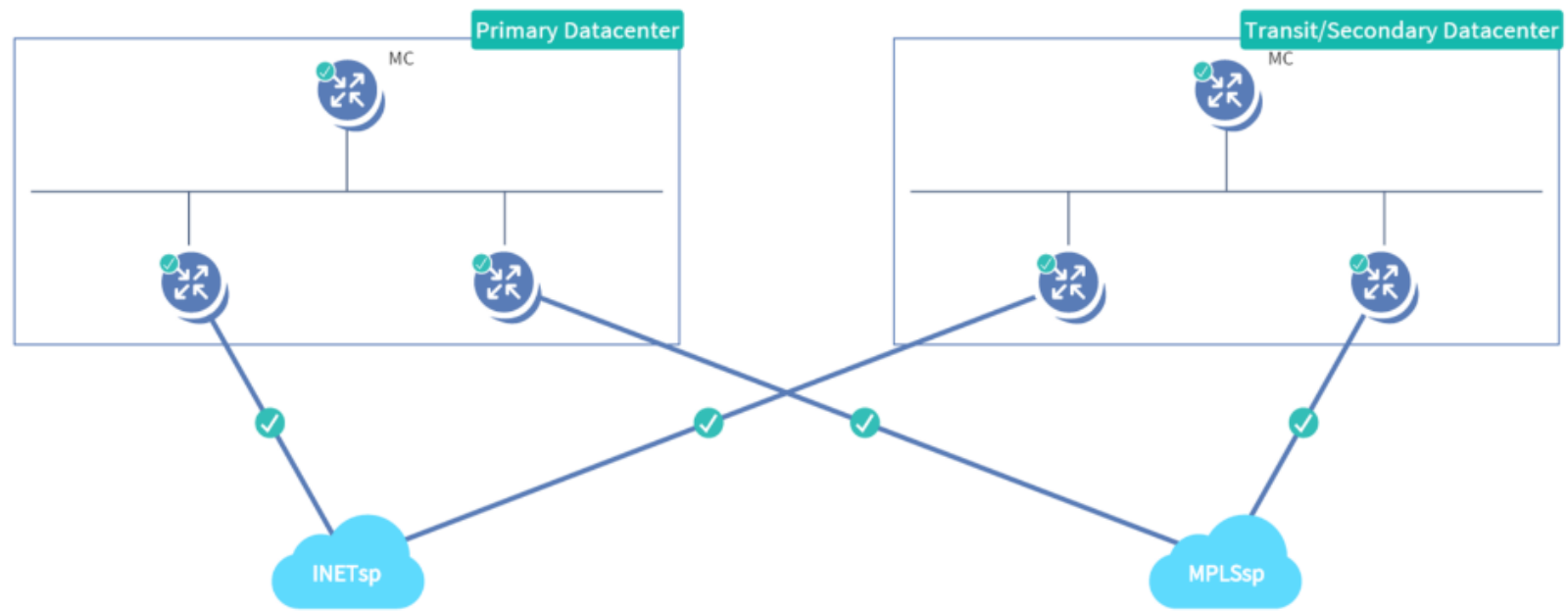

Previous

Next

Application Policy

Categorize Applications



Top 5 Application Categories

Define Application Policy

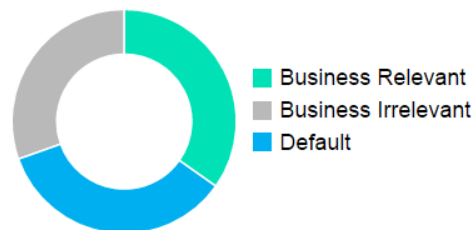

Application Bandwidth

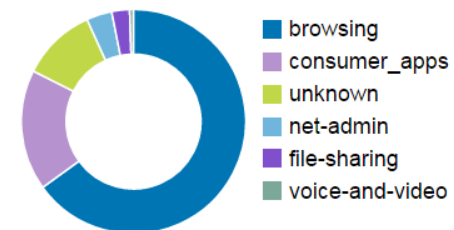

Apply Changes

Add Application

Search Apps

Applications can be dragged and dropped to other categories; By default not all the applications are visible, you can make them visible [Teach me.](#)

Not all Categories are shown by default, [Hide](#) less common categories.

anonymizers 0 ...

backup-and-storage 0 ...

browsing 4 ...

business-and-productivity-tools 18 ...

consumer_apps 48 ...

database 3 ...

email 8 ...

file-sharing 12 ...

gaming 0 ...

industrial-protocols 0 ...

instant-messaging 7 ...

inter-process-rpc 3 ...

internet-security 3 ...

layer3-over-ip 1 ...

net-admin 17 ...

other 17 ...

social-networking 6 ...

software-updates 6 ...

voice-and-video 28 ...

Application Policy

Categorize Applications



Top 5 Application Categories

Define Application Policy

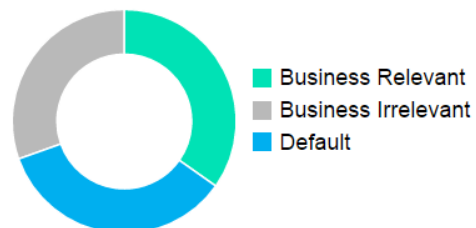

Application Bandwidth

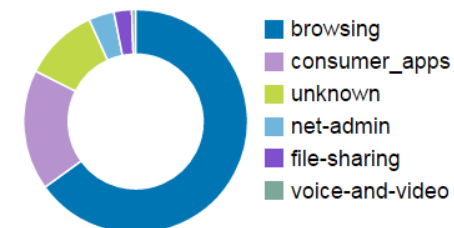

Apply Changes

Business Relevant

backup-and-storage *MPLS* ▼database *INET* ▼business-and-produ... *MPLS* ▼email *MPLS* ▼software-updates *INET* ▼voice-and-video *MPLS* ▼file-sharing *MPLS* ▼browsing *MPLS* ▼

Business Irrelevant

social-networking *No App Performance* ▼consumer-internet *No App Performance* ▼consumer... *No App Performance* ▼consumer... *No App Performance* ▼consumer... *No App Performance* ▼gaming *No App Performance* ▼instant-n... *No App Performance* ▼

Application Performance

 No path preference Path PreferencePrimary *int2* ▼Secondary *int1* ▼Last Resort *mpls*

Save

Cancel

Default

other *No App Performance* ▼epayment *No App Performance* ▼

Application Policy

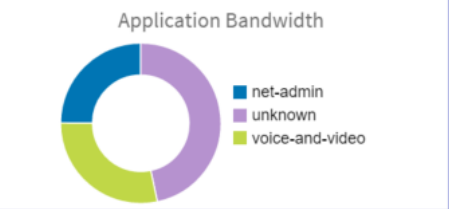
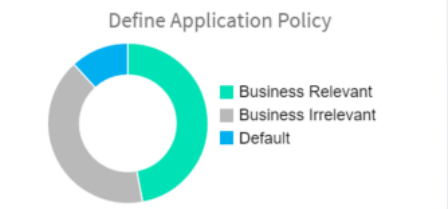

Apply Changes

Zoom: 1h | 6h | 1d | 1w | 2w | 4w | 3m

HUB

3.3.3.2 - INET

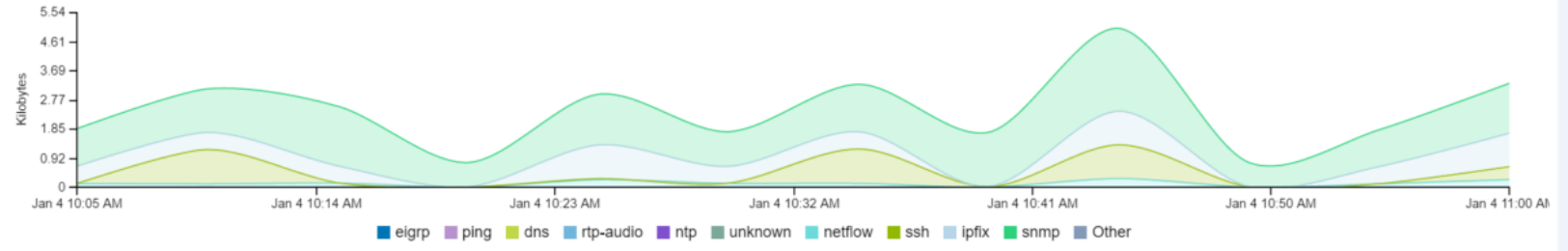

3.3.3.3 - MPLS

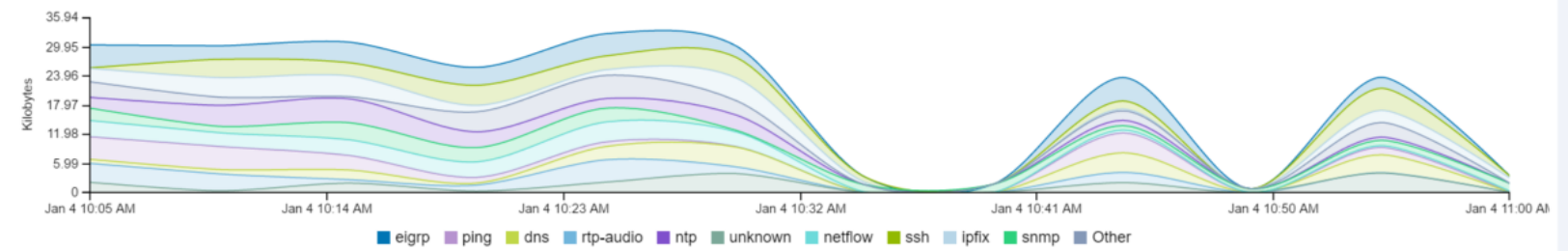

TRANSIT_HUB

3.3.3.4 - INET

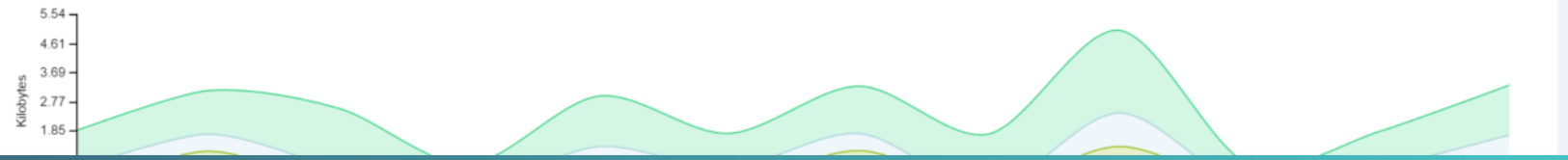
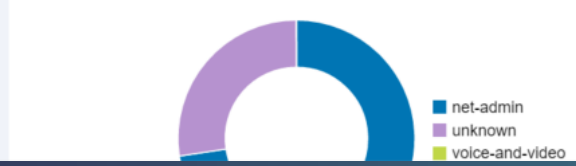

PfR Events Compare WAN Links

Time Filter: Past 24 Hours

1h | 24

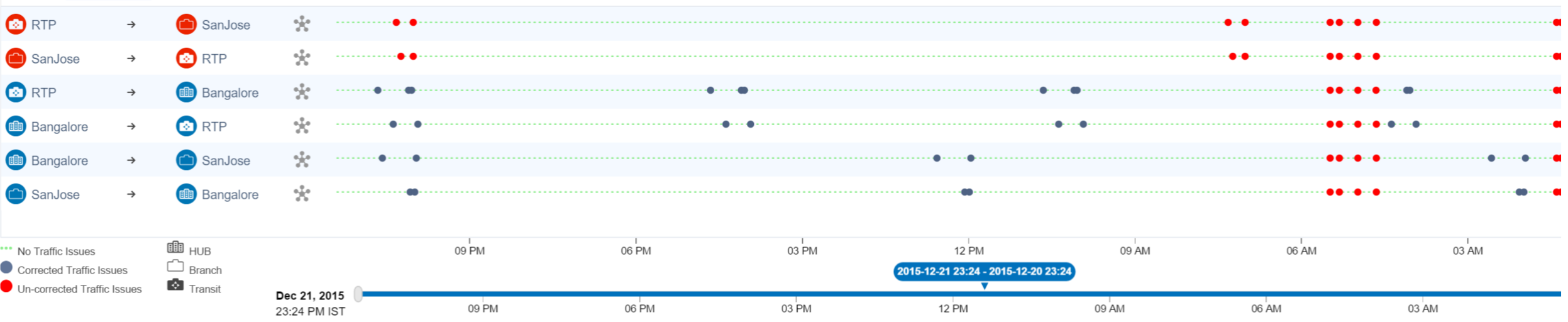

Service Provider DSCP

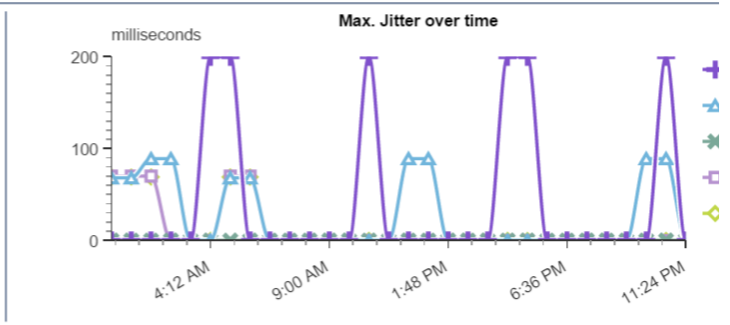
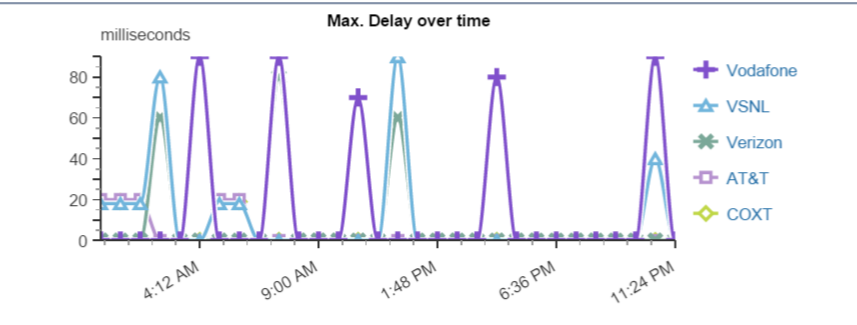
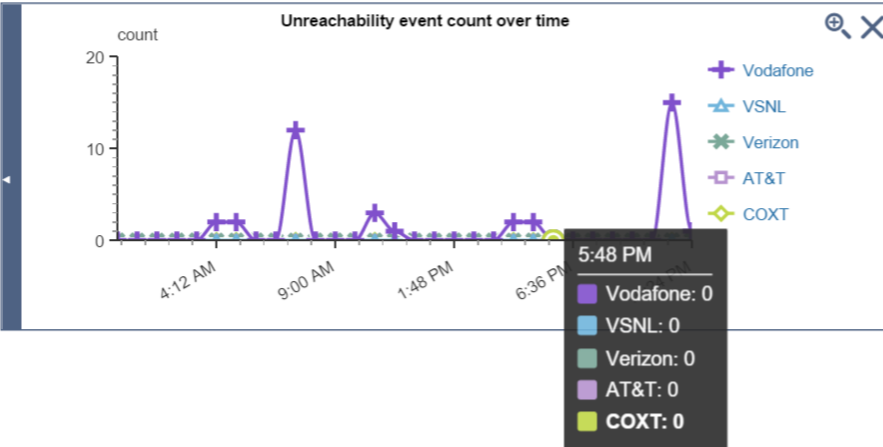

PfR Events Compare WAN Links

Time Filter: Past 24 Hours

1h | 24

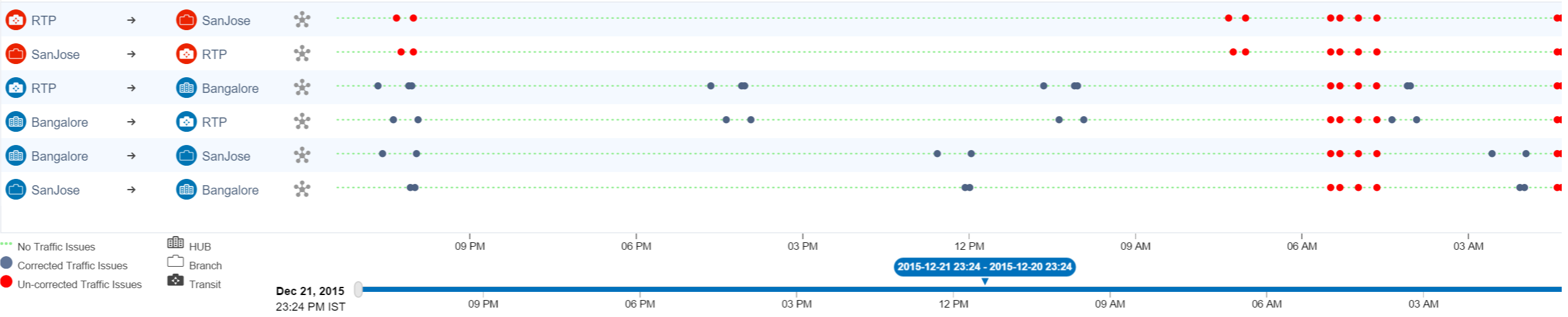

Service Provider DSCP

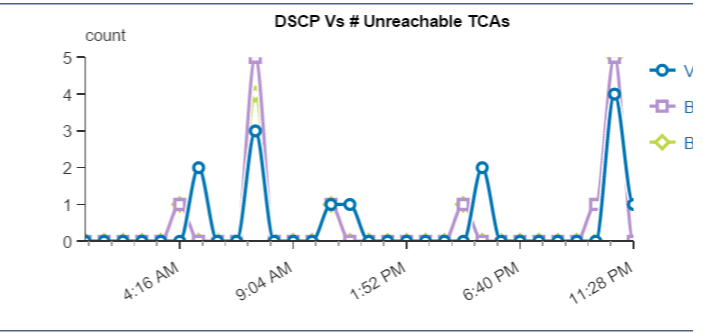
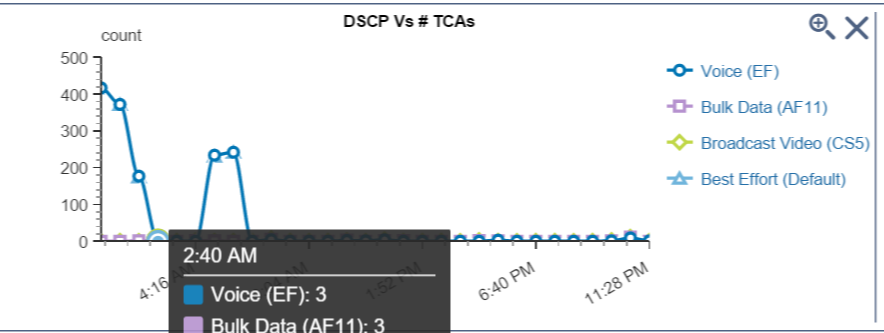
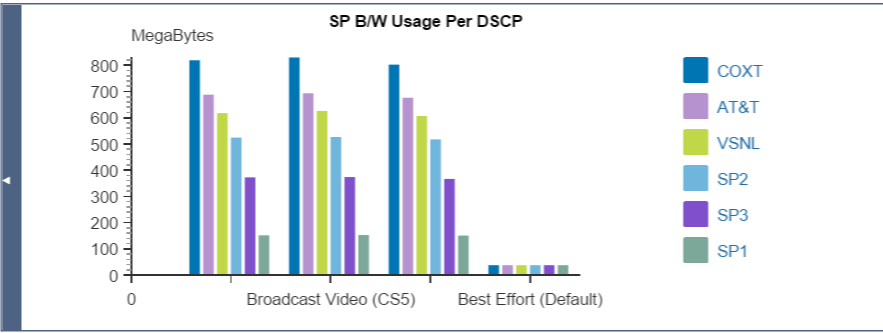

PfR Events Compare WAN Links

Time Filter: Past 24 Hours

1h | 24

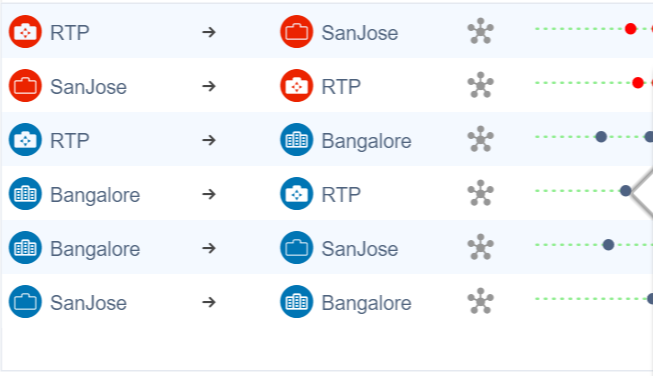

- No Traffic Issues
- Corrected Traffic Issues
- Un-corrected Traffic Issues
- HUB
- Branch
- Transit

Dec 21, 2015 23:24 PM IST

Bangalore → RTP

Time range : Dec 21, 2015 22:24 PM IST - Dec 21, 2015 22:04 PM IST

Total 6

Show Quick Filter

| Event | Servic... | Previo... | DSCP | % Pa... | Del... | J... ▲ | Rea... | Time |
|-------|-----------|-----------|-----------------------|---------|--------|---------|--------|-----------|
| TCA | Vodafone | | Broadcast Video (CS5) | 0 | 60 | 200 | ✓ | Dec 21... |
| RC | Verizon | Vodafone | Broadcast Video (CS5) | [0] | [60] | [200] | ✓ | Dec 21... |
| RC | Verizon | Verizon | Broadcast Video (CS5) | 7 | 0 | 80 | ✓ | Dec 21... |
| TCA | Vodafone | | Bulk Data (AF11) | 1 | 0 | 200 | ✓ | Dec 21... |

*[] represents a violated value resulting in RC or IME

Site to site details

Service Provider DSCP

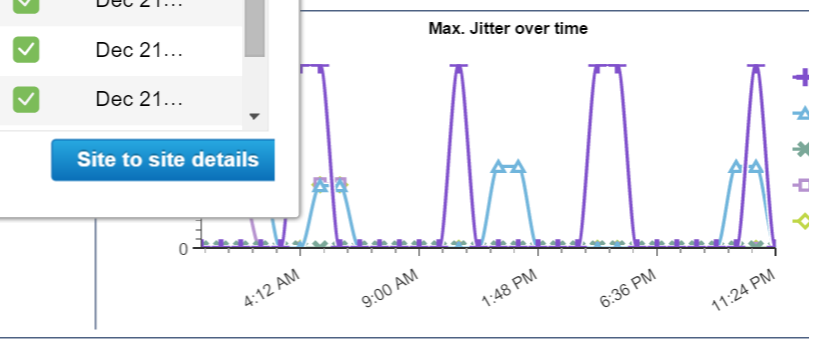
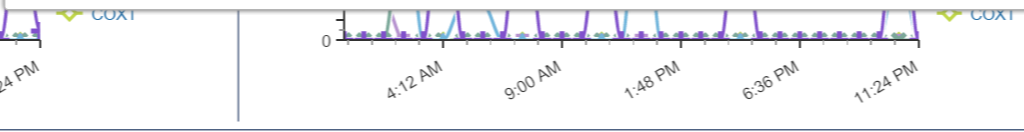
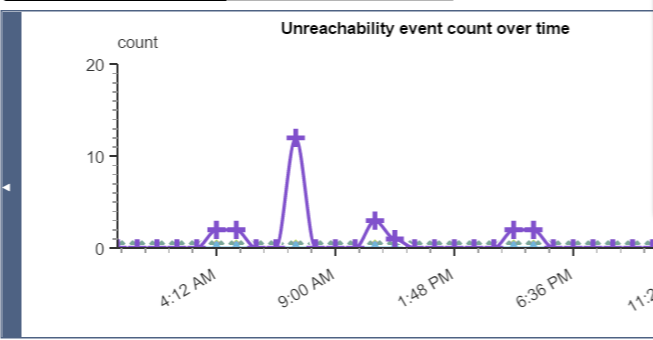

PfR Events **gasteiz → HUB** Compare WAN Links

Time Filter: 3/24/2016, 8:22 PM to 3/24/2016, 8:42 PM

Location/All Locations/gasteiz

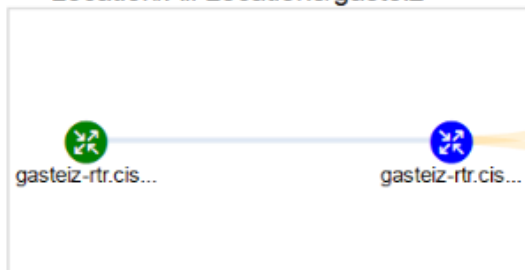

Location/All Locations/HUB

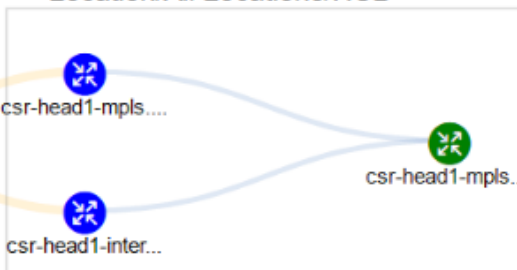

- Border Router
- Master Controller
- Service Provider
- Internal Link
- External WAN Link

All Events

| Time | Border Router | WAN Interface | SP | Previous ... | Event | DSCP | % Packet Loss | Reachability | Delay(ms) | Jitter(r) |
|----------------------------------|-----------------------|---------------|---------|--------------|-------|-----------------------|---------------|--------------|-----------|-----------|
| Mar 24, 2016 at 08:25:01 PM AEDT | gasteiz-rtr.cisco.com | | interne | mpls | RC | Best Effort (Default) | 0 | ✓ | 0 | 0 |
| Mar 24, 2016 at 08:25:01 PM AEDT | gasteiz-rtr.cisco.com | | mpls | mpls | RC | Best Effort (Default) | 0 | ✓ | 0 | 0 |
| Mar 24, 2016 at 08:25:01 PM AEDT | gasteiz-rtr.cisco.com | | interne | mpls | RC | Best Effort (Default) | 0 | ✓ | 0 | 0 |
| Mar 24, 2016 at 08:35:01 PM AEDT | gasteiz-rtr.cisco.com | | interne | interne | RC | Bulk Data (AF11) | 0 | ✓ | 0 | 0 |

PfR Events | Compare WAN Links

Events Filter: Route Change Event(s) x | Time Filter: Past 24 Hours

1h | 24h | 3d | 1w | 1m

- SanJose → Bangalore
- RTP → SanJose
- Bangalore → RTP
- RTP → Bangalore
- Bangalore → SanJose

Page 1 of 1 | Rows 1-5

No Traffic Issues HUB
Corrected Traffic Issues Branch
Un-corrected Traffic Issues Transit

Mar 22, 2016 14:02 PM IST

Service Provider View | DSCP View

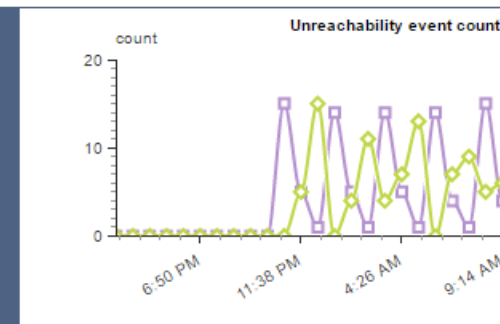

Bangalore → RTP

Time range : 14:04 - 2016-03-22 13:49 IST | 5 Mins | 15 Mins | 30 Mins | 1 Hour

Show DSCP labels View device/link metrics in pop-up dialog

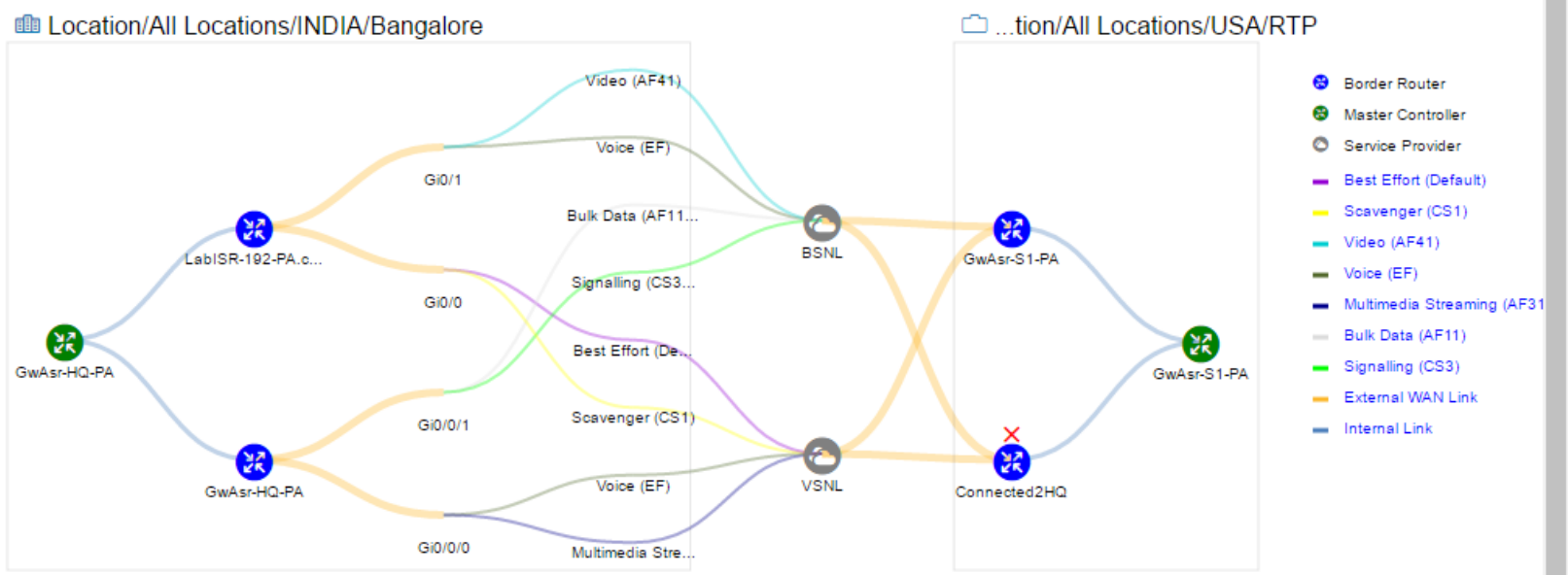

- Border Router
- Master Controller
- Service Provider
- Best Effort (Default)
- Scavenger (CS1)
- Video (AF41)
- Voice (EF)
- Multimedia Streaming (AF31)
- Bulk Data (AF11)
- Signalling (CS3)
- External WAN Link
- Internal Link

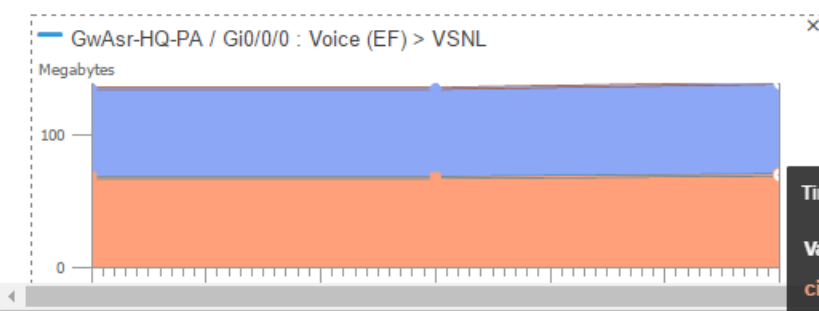

Time: 2016-03-22 14:00

Value(s) are in Megabytes

cisco-jabber-audio: 70

rtp: 70

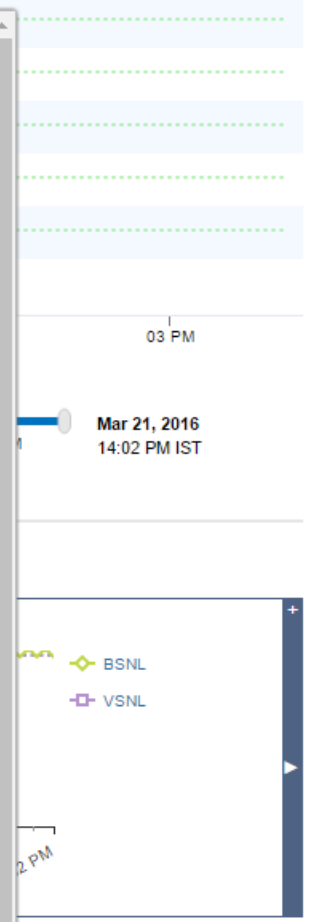

1

PfR Controlled Site gasteiz
Border Router gasteiz-rtr.cisco.com
WAN Interface / SP Tunnel11(interne)

2

PfR Controlled Site gasteiz
Border Router gasteiz-rtr.cisco.com
WAN Interface / SP Tunnel10(mpls)

+

WAN Link Utilization | Top N Application usage | BW usage trend per Qos class | Interface Availability

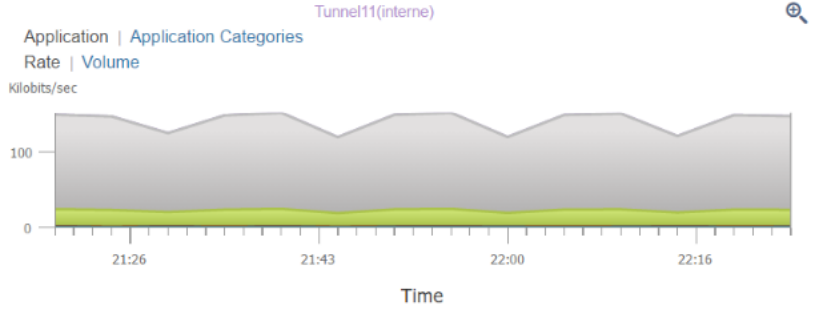

WAN Link Utilization | Top N Application usage | BW usage trend per Qos class | Interface Availability

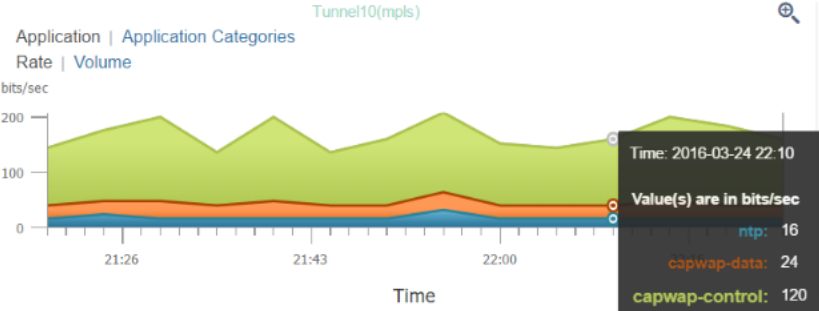

WAN Link Usage and Performance

| DSCP | Tunnel11(interne) - 200 Mbps | | | | | | Tunnel10(mpls) - 100 Mbps | | | | | |
|--|------------------------------------|------|-----|------|-------|--|------------------------------------|------|-----|------|-------|--|
| | Egress BW Usage | #TCA | #RC | #IME | #Apps | | Egress BW Usage | #TCA | #RC | #IME | #Apps | |
| Network Contro... | <input type="text" value="0.0%"/> | 0 | 0 | 0 | 2 | | <input type="text" value="0.0%"/> | 0 | 0 | 0 | 1 | |
| <div style="display: flex; justify-content: space-around;"> <div style="width: 45%;"> <p>DSCP APP</p> <p>Top Application Traffic (Out) Over Time</p> <p>Kilobytes</p> <p>Time: 22:00, 22:16</p> </div> <div style="width: 45%;"> <p>DSCP APP</p> <p>Top Application Traffic (Out) Over Time</p> <p>Kilobytes</p> <p>Time: 22:00, 22:16</p> </div> </div> | | | | | | | | | | | | |
| Best Effort (Def...) | <input type="text" value="0.0%"/> | 0 | 0 | 0 | 4 | | <input type="text" value="0.01%"/> | 0 | 0 | 0 | 3 | |
| Critical Applicat... | <input type="text" value="0.02%"/> | 0 | 0 | 0 | 0 | | <input type="text" value="0.0%"/> | 0 | 0 | 0 | 0 | |

Пусть WAN ведёт себя как LAN

Application Optimization Services

NETWORK VISIBILITY



Application Visibility and Control

- Probe-less deployment
- Wired/Wireless view of 1000+ apps
- Rapid root cause analysis

WAN PATH CONTROL



Performance Routing V3

- 2X WAN bandwidth
- Maintain App Continuity
- Lower bandwidth costs

APPLICATION ACCELERATION



Wide Area Application Service (WAAS)

- 50–70% bandwidth reduction
- 2x VDI Sessions
- Faster document processing

INTELLIGENT CACHING



Akamai Connect

- High quality Digital Experience
- Address Last Mile BW Congestion
- WAN Offload

Thank you.

