



## **Cisco Unified ICM ACD Supplement for Avaya Aura Contact Center**

July 2015

### **Corporate Headquarters**

Cisco Systems, Inc.  
170 West Tasman Drive  
San Jose, CA 95134-1706  
USA  
<http://www.cisco.com>  
Tel: 408 526-4000  
800 553-NETS (64387)  
Fax: 408 526-4100

THE SPECIFICATIONS AND INFORMATION REGARDING THE PRODUCTS IN THIS MANUAL ARE SUBJECT TO CHANGE WITHOUT NOTICE. ALL STATEMENTS, INFORMATION, AND RECOMMENDATIONS IN THIS MANUAL ARE BELIEVED TO BE ACCURATE BUT ARE PRESENTED WITHOUT WARRANTY OF ANY KIND, EXPRESS OR IMPLIED. USERS MUST TAKE FULL RESPONSIBILITY FOR THEIR APPLICATION OF ANY PRODUCTS.

THE SOFTWARE LICENSE AND LIMITED WARRANTY FOR THE ACCOMPANYING PRODUCT ARE SET FORTH IN THE INFORMATION PACKET THAT SHIPPED WITH THE PRODUCT AND ARE INCORPORATED HEREIN BY THIS REFERENCE. IF YOU ARE UNABLE TO LOCATE THE SOFTWARE LICENSE OR LIMITED WARRANTY, CONTACT YOUR CISCO REPRESENTATIVE FOR A COPY.

The Cisco implementation of TCP header compression is an adaptation of a program developed by the University of California, Berkeley (UCB) as part of UCBs public domain version of the UNIX operating system. All rights reserved. Copyright 1981, Regents of the University of California.

NOTWITHSTANDING ANY OTHER WARRANTY HEREIN, ALL DOCUMENT FILES AND SOFTWARE OF THESE SUPPLIERS ARE PROVIDED "AS IS" WITH ALL FAULTS. CISCO AND THE ABOVE-NAMED SUPPLIERS DISCLAIM ALL WARRANTIES, EXPRESSED OR IMPLIED, INCLUDING, WITHOUT LIMITATION, THOSE OF MERCHANTABILITY, FITNESS FOR A PARTICULAR PURPOSE AND NON-INFRINGEMENT OR ARISING FROM A COURSE OF DEALING, USAGE, OR TRADE PRACTICE.

IN NO EVENT SHALL CISCO OR ITS SUPPLIERS BE LIABLE FOR ANY INDIRECT, SPECIAL, CONSEQUENTIAL, OR INCIDENTAL DAMAGES, INCLUDING, WITHOUT LIMITATION, LOST PROFITS OR LOSS OR DAMAGE TO DATA ARISING OUT OF THE USE OR INABILITY TO USE THIS MANUAL, EVEN IF CISCO OR ITS SUPPLIERS HAVE BEEN ADVISED OF THE POSSIBILITY OF SUCH DAMAGES.

Cisco and the Cisco logo are trademarks or registered trademarks of Cisco and/or its affiliates in the U.S. and other countries. To view a list of Cisco trademarks, go to this URL: [www.cisco.com/go/trademarks](http://www.cisco.com/go/trademarks). Third-party trademarks mentioned are the property of their respective owners. The use of the word partner does not imply a partnership relationship between Cisco and any other company. (1110R)

Copyright 2015 Cisco Systems, Inc. All rights reserved.

---

# Contents

<b>Cisco Unified ICM ACD Supplement for Avaya Aura Contact Center .....</b>	<b>i</b>
<b>Contents .....</b>	<b>iii</b>
<b>Preface .....</b>	<b>9</b>
<b>1. Overview .....</b>	<b>13</b>
<b>1.1. ACD Interface Requirements .....</b>	<b>14</b>
1.1.1. 60BAura Contact Center ACD Scripts.....	15
1.1.2. 61BAura Contact Center ACD Applications and Skill Sets ...	15
1.1.3. 62BSwap Feature in Aura Contact Center ACD .....	16
1.1.4. 63BHardware and Software Requirements .....	19
1.1.5. 64BSpecial Requirements .....	20
1.1.6. 65BSupported Unified ICM Software Features .....	20
1.1.7. 66BMultiple Application Support.....	20
1.1.8. 67BGeneral Restrictions.....	20
1.1.9. 68BCTI Server Restrictions .....	21
<b>1.2. Aura Contact Center PG Platform Requirements .....</b>	<b>23</b>
<b>1.3. Working with Unified ICM MRs and ESs.....</b>	<b>23</b>
<b>2. ACD Configuration .....</b>	<b>25</b>
<b>2.1. Configuration Prerequisites.....</b>	<b>26</b>
<b>2.2. Script Modifications for Call Processing.....</b>	<b>26</b>
2.2.1. 69BArrived .....	27
2.2.2. 70BInterflowed.....	28
2.2.3. 71BEnqueued.....	29
2.2.4. 72BEnqueued_MLA .....	29
2.2.5. 73BEnqueued_MLA_Begin, Enqueued_MLA_Next, Enqueued_MLA_End.....	29
2.2.6. 74BEnqueued_Agent .....	30
2.2.7. 75BDequeued.....	30
2.2.8. 76BDequeued_Agent .....	30
2.2.9. 77BNACD_Queued .....	30

2.2.10.	78BNACD_Ping .....	31
2.2.11.	79BNACD_Dequeued .....	32
2.2.12.	80BRouted.....	32
2.2.13.	81BGive_Busy.....	33
2.2.14.	82BGive_Overflow.....	34
2.2.15.	83BControlled_Returned .....	34
2.2.16.	84BDisconnect.....	34
<b>2.3.</b>	<b>Script Modifications for Post-Routing .....</b>	<b>34</b>
<b>2.4.</b>	<b>Meridian 1 Configuration.....</b>	<b>34</b>
<b>2.5.</b>	<b>IVR Port Configuration and Considerations .....</b>	<b>35</b>
<b>2.6.</b>	<b>Meridian Mail Considerations .....</b>	<b>35</b>
<b>2.7.</b>	<b>NCCM Server Capacity Considerations.....</b>	<b>36</b>
<b>3.</b>	<b>Web Setup Tool and Configuration .....</b>	<b>37</b>
<b>3.1.</b>	<b>Web Setup Tool.....</b>	<b>38</b>
3.1.1.	85BInstalling the Aura Contact Center PG .....	38
3.1.2.	86BMeridian Link Configuration .....	39
3.1.3.	87BRTD Configuration .....	40
3.1.4.	88BHDX Configuration .....	40
<b>3.2.</b>	<b>Unified ICM Software Configuration .....</b>	<b>40</b>
3.2.1.	89BPeripheral Configuration .....	41
3.2.2.	90BPeripheral Target Configuration .....	41
3.2.3.	91BTrunk Group Configuration.....	42
3.2.4.	92BTrunk Configuration.....	43
3.2.5.	93BService Configuration.....	43
3.2.6.	94BSkill Group Configuration .....	43
3.2.7.	95BService Member Mappings .....	44
3.2.8.	96BAgent Configuration .....	44
3.2.9.	97BAgent State Mapping.....	45
3.2.10.	98BSkill Group Member Mappings.....	45
3.2.11.	99BTranslation Routes .....	46
3.2.12.	100BRoute Configuration .....	46
3.2.13.	101BRouting Client Configuration .....	46
3.2.14.	102BPeripheral Monitor Configuration of Aura Contact Center CDNs	46
3.2.15.	103BPeripheral Monitor Configuration of Aura Contact Center Positions	46
<b>3.3.</b>	<b>IVR Port Configurations .....</b>	<b>48</b>
<b>3.4.</b>	<b>Activity Code Configuration .....</b>	<b>48</b>
3.4.1.	Unified ICM Configuration .....	48
3.4.2.	10CTCTCTI OS Server Configuration .....	48
3.4.3.	106BMeridian PBX and SCCS Configuration.....	48
<b>3.5.</b>	<b>Special Considerations in NAM Environments.....</b>	<b>49</b>

<b>3.6. Maintaining Your Configuration .....</b>	<b>49</b>
<b>4. Post-Routing.....</b>	<b>51</b>
<b>4.1. Changes to the NCCM server Configuration.....</b>	<b>52</b>
4.1.1. 107BReserve CDNs or DNISs.....	52
4.1.2. 108BDO_POST_ROUTE Section of Master Script .....	52
4.1.3. 109BExample of Post-Routing Section in Master Script .....	54
<b>4.2. Changes to the Unified ICM Software Configuration .....</b>	<b>57</b>
4.2.1. 110BLabels.....	57
4.2.2. 111BCall Control Variable Map .....	57
<b>4.3. 39BCaller Entered Digits.....</b>	<b>58</b>
<b>4.4. Translation Routing .....</b>	<b>58</b>
4.4.1. 112BReview of How to Configure Translation Routes .....	58
4.4.2. 113BAura Contact Center Post-Routed Translation Routes .	59
<b>5. ACD-Specific Interpretation of Unified ICM Software Data .....</b>	<b>61</b>
<b>5.1. Method of Attributing Calls to Services.....</b>	<b>62</b>
<b>5.2. Method of Attributing Calls to Skill Groups .....</b>	<b>62</b>
<b>5.3. Calculation of Handle Time.....</b>	<b>62</b>
<b>5.4. Handling of ROUTE CALL Script Command .....</b>	<b>63</b>
<b>5.5. Handling of ROUTE CALL CONTROLLED Script Command .....</b>	<b>63</b>
<b>5.6. Handling of QUEUE TO NACD Script Command .....</b>	<b>64</b>
<b>5.7. Handling of GIVE BUSY Script Command.....</b>	<b>65</b>
<b>5.8. Handling of GIVE BUSY CONTROLLED Script Command.....</b>	<b>65</b>
<b>5.9. Handling of GIVE OVERFLOW Script Command.....</b>	<b>65</b>
<b>5.10. Handling of GIVE OVERFLOW CONTROLLED Script Command .....</b>	<b>66</b>
<b>5.11. Handling of DISCONNECT Script Command .....</b>	<b>66</b>
<b>5.12. Handling of Trunk Group Statistics .....</b>	<b>66</b>
<b>5.13. Enhancements to the Dialed Number List Tool.....</b>	<b>66</b>
<b>6. SEI Lite Interface with Avaya Aura Contact Center ...</b>	<b>67</b>

<b>6.1. Supporting Agent Re-skilling at the Unified ICM Software.....</b>	<b>68</b>
<b>6.2. Using the SEI Lite Feature with AAS.....</b>	<b>68</b>
6.2.1. 134BMinimum System Requirements .....	69
6.2.2. 135BKnown Limitations of the SEI Lite Feature .....	69
<b>Index .....</b>	<b>1</b>

**Tables**

Table 1: Symposium ACD Requirements ..... 19  
Table 2: Symposium-to-ICM Agent State Mapping ..... 46  
Table 3: Param String Format Examples ..... 48

**Figures**

Figure 1: Symposium Hardware Configuration ..... 14  
  
Figure 4: Unified ICM Software Setup 4.5, SP1 (for  
Symposium ACD 1.5, 3.0, or 4.0/4.2) ..... 39



---

# Preface

## Purpose

This document contains the specific information you need to maintain an Aura Contact Center Peripheral Gateway (PG) in a Cisco Unified Contact Center Enterprise (Unified CCE) environment. It is intended to be used as the Aura Contact Center-specific companion to the Cisco Unified ICM software documentation set.

While other Unified ICM documents (for example, the *Configuration Guide for Cisco Unified ICM/Contact Center Enterprise & Hosted*) cover general topics such as configuring an overall Unified ICM system and writing scripts to route contact center requests, this document provides specific information on configuring an Aura Contact Center PG and making any necessary adjustments to the Aura Contact Center ACD configuration.

## Audience

This document is intended for Unified ICM system managers. The reader should understand functions of the Unified ICM software as described in the following documents:

1. *Cisco Unified Contact Center Enterprise Installation and Upgrade Guide*
2. *Configuration Guide for Cisco Unified ICM/Contact Center Enterprise & Hosted*
3. *Scripting and Media Routing Guide for Cisco Unified ICM/Contact Center Enterprise & Hosted*

The reader should also have specific knowledge of the Avaya Aura Contact Center ACD.

## Organization

Chapter 1, “Overview”

Provides an overview of ACD interface and hardware and software requirements.

Chapter 2, “ACD Configuration”

Describes items in the Aura Contact Center configuration that must be changed to ensure compatibility with Unified ICM.

Chapter 3, “Web Setup Tool and Configuration”

Provides specific information on setting up an Aura Contact Center PG by using the Web Setup tool, and configuring an Aura Contact Center PG by using the Unified ICM configuration tools. This chapter also describes the relationships between the Aura Contact Center ACD objects and the Unified ICM database objects.

#### Chapter 4, “Post-Routing”

Describes the changes you must make to Unified ICM configuration, the Nortel Contact Center Manager (NCCM) server configuration, and the NCCM server scripts in order to post-route calls using the Aura Contact Center PG.

#### Chapter 5, “ACD-Specific Interpretation of Unified ICM Data”

Discusses the issues you might face when you attempt to compare the Unified ICM database reporting elements and Aura Contact Center ACD reporting elements.

#### Chapter 7, “SEI Lite Interface with Avaya Aura Contact Center”

Outlines what the Symposium Event Link (SEI Lite) feature is about and how it interfaces between the Automated Administrator for Symposium (AAS) and the NCCM server.

## Typographic Conventions

This manual uses the following conventions:

- Boldface type is used for emphasis; for example:  
Real-time information **is not** stored in the central database.
- Italic type indicates one of the following:
  - A newly introduced term; for example:  
*A skill group* is a collection of agents who share similar skills.
  - A generic syntax item that you must replace with a specific value; for example:  
IF (*condition, true-value, false-value*)
- A title of a publication; for example:  
For more information see the following guide:
  - *Cisco Unified Contact Center Enterprise Installation and Upgrade Guide*
- Sans serif type with small caps is used to represent keys on your keyboard; for example:  
Press the SHIFT key to select a range of items.
- An arrow (→) indicates an item from a pull-down menu. For example, the Save command from the File menu is referenced as File→Save.

## Other Publications

For more information on the Unified ICM software, see the following documents:

- *Administration Guide for Cisco Unified ICM/Contact Center Enterprise & Hosted*
- *Cisco Unified Contact Center Enterprise Installation and Upgrade Guide*
- *Configuration Guide for Cisco Unified ICM/Contact Center Enterprise & Hosted*
- *Product Description Guide for Cisco Unified ICM Hosted*
- *Scripting and Media Routing Guide for Cisco Unified ICM Enterprise*

For information on Cisco Network Applications Manager (NAM), see:

- *Cisco Network Applications Manager (NAM) Product Description*

For information on Automated Administrator for Symposium (AAS), see:

- *Cisco Unified ICM Automated Administrator for Symposium (AAS) Installation and Troubleshooting Guide*

## Obtaining Documentation, Obtaining Support, and Security Guidelines

For information on obtaining documentation, obtaining support, security guidelines, and general Cisco documents, see the monthly *What's New in Cisco Product Documentation*, which also lists all new and revised Cisco technical documentation, at:

<http://www.cisco.com/en/US/docs/general/whatsnew/whatsnew.html>

## Documentation Feedback

You can provide comments about this document by sending email to the following address:

[cbu\\_docfeedback@cisco.com](mailto:cbu_docfeedback@cisco.com)

We appreciate your comments.



---

# 1. Overview

The Aura Contact Center PG communicates with the Nortel Contact Center Manager (NCCM) server to obtain call and agent state information. Specifically, the PG communicates with the NCCM server by using three interfaces. All **three** interfaces are required by the PG:

- **Meridian Link Interface (MLink)**. This interface is used to obtain information about call state. It also supplements the agent state information provided by the RTD interface and implements third-party call and agent control.
- **Host Data Exchange Interface (HDX)**. This interface is used to supplement the call state information provided by the MLink interface. It is also used to implement software post-routing.
- **Real Time Data Interface (RTD)**. This interface is used to obtain information about agent state. It also supplements the call state information provided by the Meridian Link Interface.

The software to support these interfaces runs on the NCCM server.

This chapter provides an overview of the Aura Contact Center ACD interface, and presents the hardware and software requirements for Aura Contact Center ACD (required to interact with the software).

## 1.1. ACD Interface Requirements

An Aura Contact Center ACD configuration consists of a Meridian 1 switch (Option 11C, Option 51C), a NCCM server (formerly known as Aura Contact Center Server or SCCS), a switch Administration & Data Server (ADS). The Meridian 1 switch, the NCCM server, and switch ADS are connected together via a private Ethernet subnet that Avaya refers to as an ELAN. (See Figure 1.)

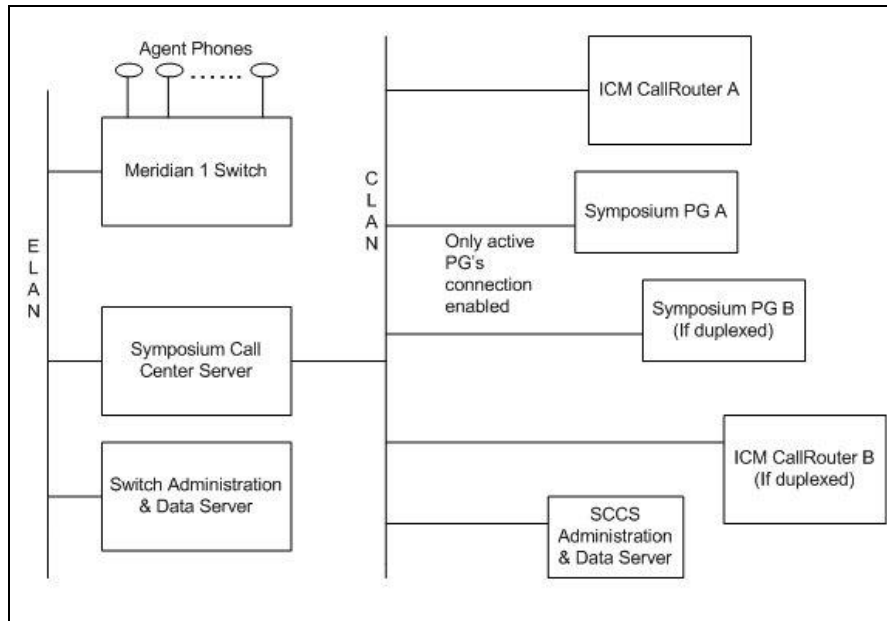

**Figure 1: Aura Contact Center Hardware Configuration**

The NCCM server is also attached to a public Ethernet subnet called a CLAN. The NCCM (NCCM) Administration & Data Server and the nodes on which the system software runs (PGs, CallRouter, etc.) are also attached to the CLAN. All communication is based on TCP/IP.

The Aura Contact Center Peripheral Gateway (PG) can run in simplex or duplexed configurations. In a duplexed configuration, only one side of the PG communicates with the ACD at any given time.

The Meridian 1 switch performs basic telephone switching functions. Most of the intelligence of the system is in the NCCM server. The only way Unified ICM can communicate with Aura Contact Center is via the NCCM server.

The Aura Contact Center PIM **does not support** configurations that use Nortel's Meridian Link Services 4.0 on a NCCM server. Meridian Link Services 4.0 is supported only for the Meridian PIM.

While configuring the Network Interface Controller (NIC) cards and switch ports, ensure that:

- The speed and duplexity of the PGs and switch are set to 100Mbps/full duplex.
- The network bindings on the PGs have the visible network listed first.

*See also:* For more information on the Meridian Link Services 4.0 and Meridian PIM configuration, see the *Cisco Unified ICM ACD Supplement for Nortel Meridian*.

### 1.1.1. Aura Contact Center ACD Scripts

In an Aura Contact Center ACD, all calls are processed by *scripts* that are written by call center administrators and run on the NCCM server.<sup>1</sup> These scripts determine caller attributes and make call treatment and queuing decisions for each call.

Every call being handled by a NCCM server system is sent to the *master script*. This script typically functions as a filter that invokes other scripts to handle the call, depending on the nature of the call and status of call center resources. A script that is directly invoked by the master script is called a *primary script*. A primary script may, in turn, invoke *secondary scripts* to handle some of the processing.

For a call to be handled by the NCCM server, it must terminate on a Meridian 1 Controlled DN (CDN) that has been acquired by the NCCM server. That is, the switch must be configured to associate CDNs with the NCCM server. Calls to switch resources that have not been acquired by the NCCM server will not be seen by the NCCM server.<sup>2</sup> Any number of CDNs can be acquired by the NCCM server. A call terminating on any of these will invoke the **same** master script, which will then determine how the call will be handled.

### 1.1.2. Aura Contact Center ACD Applications and Skill Sets

The activity undertaken by a primary script and its subordinate secondary scripts is referred to as an *application*. All primary scripts and the master

---

<sup>1</sup> NCCM Server scripts (formerly known as SCCS scripts) are completely distinct from CallRouter scripts. NCCM Server scripts run on the NCCM Server. They determine how a call is processed once it arrives at the server. For pre-routed calls, CallRouter scripts determine which Meridian 1 trunk group and DNIS the call is presented to. The Meridian 1 switch passes this information on to the NCCM Server when it delivers the call to the server. The NCCM Server scripts can then use the information to help make call processing decisions. For post-routed calls, CallRouter scripts determine what response type and response value are returned to the NCCM Server script that made the post-route request. (See Chapter 4 for more information on Post-Routing.)

<sup>2</sup> For example, a call center might have a Meridian switch that is configured with ACD-DNs (ACD queues) as well as NCCM Server CDNs.

script have corresponding applications against which performance information is gathered.

For example, a call center might have two scripts in addition to the master script, perhaps a “Sales script” and a “Service script.” All performance information (e.g., calls answered, calls abandoned) for calls being handled by the Sales script are pegged against the corresponding Sales application.

Note that the application associated with a call is determined by the **first** primary script that is executed for that call. That is, the application associated with a call does not change if the first primary script transfers control to another primary script.

A NCCM server system implements skills-based routing through *skill set* assignment. Agents can be assigned to multiple skill sets, and calls can be queued to multiple skill sets<sup>1</sup>.

### 1.1.3. Swap Feature in Aura Contact Center ACD

The Swap feature enables the agents to swap, or exchange between the customer calls and the consult calls, both from hardphones as well as softphones.

The Swap feature deploys a CTI toolbar with Unified ICM, offering most of the phone set functionalities. One of the most important functionalities is that it allows the agent to swap or alternate between primary and consult calls during a Consultation Call.

The agent performing the transfer must carry out a swap, or alternate between the primary key (ACD or DN) and the secondary key of transfer. On the phone set, a swap can be performed by using the transfer or primary key of the used line (ACD or DN).

---

<sup>1</sup>. Calls are no longer queued to ACD-DNs as they were in previous Nortel products.

### **Dependencies and patches for the Swap feature support in SoftPhones and HardPhones:**

The following patches are required for Swap feature support on:

#### **Aura Contact Center SCCS 5.0:**

- SU 05
- SUS0501/02/03
- NN\_SCCS\_5.0\_DP\_050302\_S [mandatory]
- NN\_SCCS\_5.0\_DP\_050301\_S [optional]

#### **NCCM 6.0:**

- SU03
- SUS0301
- PEP\_030130\_RU

#### **Meridian Option11C switch with Release 25.40B:**

- MPLR18683
- MPLR20429
- MPLR19115

#### **Nortel CS1000 Succession 4.0 or 4.5:**

- MPLR20429
- MPLR21764

### **Enabling Swap Feature on Meridian PBX**

The Swap feature must be enabled for the respective Agent sets at the Meridian switch. The AHA (Automatic hold allowed) class of service must be enabled for the respective Agent sets.

Following are the commands to be executed to enable this feature at the Meridian switch.

1. Login to Meridian ACD
2. At the prompt enter
3. ld 20  
REQ> PRT  
> DNB  
> 4001
4. Get the TN number (E.g. 5 0 00 0X)
5. Enable the feature for the TN

```
REQ > CHG (change)
TYPE > 2616 (Teleset type)
TN   > 5 X  (TN no. for the DN 4XXX)
ECHG yes
```

```
ITEM > cls aha (code to enable feature)
>**** (to save and exit)
```

**Note:** Meridian Option11C switch with Release 25.40B is no longer supported with Unified ICM. For the latest and updated information on Unified ICM-ACD supportability, refer *Cisco Unified ICM Supported Switches (ACDs)* at:  
[http://www.cisco.com/en/US/products/sw/custcosw/ps1001/prod\\_technical\\_reference\\_list.html](http://www.cisco.com/en/US/products/sw/custcosw/ps1001/prod_technical_reference_list.html)

### **Enabling Swap Feature on Unified ICM**

The Swap feature can be enabled with the help of Config REGISTRY Key called *NortelSwapPatchInstalled*. This key is created when the patch is installed. Set the value of this registry key to 1 before starting the PG.

If there are multiple instances of Aura Contact Center PG in the same box, the registry *NortelSwapPatchInstalled* needs to be set it to 1 for all the PG instances. This allows the CTIOS server to enable the alternate button on the client desktop.

### 1.1.4. Hardware and Software Requirements

To work with the system software, the Aura Contact Center must be configured with the hardware and software listed in Table 1.

**Table 1: Aura Contact Center ACD Requirements**

<b>Releases Supported</b>	<p>For specific release information for Aura Contact Center, see the <i>Cisco Unified ICM Supported Switches (ACDs)</i> document, located at Cisco.com.</p> <p><b>Note:</b> The software on the Meridian 1 switch must be compatible with the release of Aura Contact Center.</p>
<b>Meridian Link Server Requirements</b>	<p>The Meridian Link Server must be equipped with the following options:</p> <ul style="list-style-type: none"> <li>- Host Enhanced Routing</li> <li>- In-Bound Call Management</li> <li>- Out-Bound Call Management</li> </ul>
<b>Meridian 1 Requirements</b>	<p>The Meridian 1 must be equipped with enough Associate Set Assignment (AST) licenses so that all ACD positions can be configured as AST. Consult your Avaya representative to ensure that you have the appropriate level of AST support installed through Incremental Software Management (ISM).</p>
<b>ACD Interface Requirements</b>	<p>The Aura Contact Center must support the following interfaces. The Aura Contact Center PG requires all three of them:</p> <ul style="list-style-type: none"> <li>Meridian Link Interface (MLink)</li> <li>Real-Time Data (RTD)</li> <li>Host Data Exchange (HDX)</li> </ul>

### 1.1.5. Special Requirements

- The HDX interface requires that the NCCM server scripts be modified to include SEND INFO commands that notify Unified ICM when a call state transition occurs. (See Chapter 2, “ACD Configuration,” for more information.)
- You must set up the Avaya HDX and RTD client communications environment on the machine on which the Aura Contact Center PG will run. (See “Aura Contact Center PG Platform Requirements,” later in this chapter for more information.)
- For an agent to login successfully (either manually or through a CTI application), the phone has to be in “Off Hook” mode.

### 1.1.6. Supported Unified ICM Software Features

The Aura Contact Center PG supports the following software features:

- Pre-Routing
- Post-Routing
- Enterprise CTI (includes third-party call control)
- Agent Reporting
- Duplexed PG implementation
- SEI Lite Interface with NCCM server along with Automated Administrator for Aura Contact Center “(AAS)”<sup>1</sup>

### 1.1.7. Multiple Application Support

The current release of the Avaya HDX software allows only one application at a time to use the HDX interface. Therefore, you cannot run any other application that uses the HDX interface while the software is running.

### 1.1.8. General Restrictions

- Peripheral service level reporting is not supported by the Aura Contact Center PG.
- Due to limitations in the Avaya interfaces, the Aura Contact Center PG does not support the system software Trunk Group real-time data elements or Trunk Group half-hour data elements.
- Using Network ACD to divert calls to another NCCM server system will cause Unified ICM to report inaccurate data because the NCCM server does not report the progress of these calls to the PG. Therefore, it is recommended not to use the QUEUE TO NACD command in your NCCM server scripts.
- You **must not** specify an NACD DN<sup>1</sup> as the target of a ROUTE CALL command in your NCCM server scripts. If you must use NACD DNs,

---

<sup>1</sup> AAS supports ICM Releases 7.0(0) onward.

use the QUEUE TO NACD command – understanding that Unified ICM software reporting will then be inaccurate, as mentioned in the preceding bullet. However, the recommendation is that you find an alternate method that does not use NACD DNs.

- Avaya’s Network Skillset feature is not supported.
- The Aura Contact Center PG **does not** support Agent IDs, Position IDs, Extension IDs and CDNs that start with a zero.
- Call takeback and transfer operations are not supported by the Aura Contact Center PG.
- When the active Aura Contact Center PG fails over to the other side, the call control is lost on the CTI OS desktop. However, the call will be retained on the hard set. Also, agents who had active calls will resume their CTI operation on the agent desktop, after they are in the IDLE state on the ACD. This scenario is also observed for the MLSM service restarts on the switch during the call.

### 1.1.9. CTI Server Restrictions

- The Peripheral Gateway (and thus CTI clients) will not receive a CallEstablished Event for an off-switch call. As a result of this limitation, the feature *conference operation on off-switch* is not supported. The soft-phone has no way to know that the call has been connected off-switch, and thus the application requires manual intervention from the agent (who will either hear a dial-tone, a ring, or an answer, etc.) before completing the conference or transfer operation.
- The Transfer button is not enabled after an off-switch consult.
- Consultative Transfer to a Supervisor is not supported.
- Single-Step Conference is not supported.
- One is unable to transfer to an AgentID.
- One is unable to put a conference or consultative call on hold, therefore the button is disabled.
- There is a delay in switching from the NotReady state to the Ready state
- There is no equivalent to the Aura Contact Center state WalkAway. The ACD gives a NOT\_READY state to Unified ICM, but the switch will reject a request to set WalkAway to Not\_Ready.
- Third-party call control and agent control requests issued through the CTI Server interface sometimes return a Peripheral error code in the failure indication message if the request fails. For the Avaya Aura Contact Center, this Peripheral error code is either a Status value or a Cause value. Generally, Status values are returned for call requests

---

<sup>1</sup> That is, an ACD DN that has a day table or a night table (or both) associated with it.

such as MakeCall and Cause values are returned for agent control requests such as SetAgentState.

- The Aura Contact Center PG attributes answered calls to that skill group which corresponds to the NCCM server (formerly, SCCS) skill set in which the agent answered the particular call. Due to limitations in the Avaya Aura Contact Center interface, the PG needs several seconds after the queued call is answered by an agent to attribute the call to a particular skill group. Hence, there is a corresponding 15-20 second delay in the CTI interface before third party control is established.

For more information on peripheral-specific CTI support, see the *CTI OS Developer's Guide for Cisco Unified ICM/Contact Center Enterprise & Hosted*.

## 1.2. Aura Contact Center PG Platform Requirements

You must set up the Avaya HDX and RTD client communications environment on the machine(s) on which you will run Aura Contact Center PG(s).

*See also:* See “Configuring the Communications Environment” in *Nortel Host Data Exchange API Programmer’s Guide* and *Nortel Real Time Data API Programmer’s Guide* for information on setting up the Nortel HDX and RTD client communications environment.

If you do not set up the PG with the HDX and RTD communications environment, the Aura Contact Center PG will not be able to connect to the HDX and RTD servers running on your NCCM server system (but it will be able to connect to the Meridian Link server on the NCCM server system).

**Note:**

- To set up the communications environment, install the `nicoms_1.exe` and `nbnmsvc.exe` programs as described in the Avaya documents referenced earlier. These programs are on the client application CD that came with your Aura Contact Center Server.
- The Aura Contact Center PG does not support RTD compression; therefore, ensure that RTD compression is *disabled* on the NCCM server. The RTD Compression is *not supported* for SDK 6.0 installation. To verify if the compression is disabled on the NCCM server, choose **Start >All Programs >Nortel Contact Center > Manager Server > Multicast Stream Control**, and ensure that the “compression” check box is not checked.

**Important:** NCCM server does not allow connections from multiple PGs to avoid HDX messages being missed from the Aura Contact Center PIM, due to improper monitoring and scripting errors.

- When installing the SDK, you must manually copy the `.dll` files from the SDK folder and place them in the `icm/bin` directory. For more information, please check the Release Notes that were shipped with the SDK.

## 1.3. Working with Unified ICM MRs and ESs

When working with Unified ICM Software Maintenance Releases (MRs) and Engineering Specials (ESs), be sure to follow all instructions in the hot-fix read-me file. The hot-fix read-me file contains release-specific instructions that must be followed to ensure proper installation of the PIM.



---

## 2. ACD Configuration

Some configuration settings on the Aura Contact Center ACD must be changed to ensure proper operation with Unified ICM. For example, the NCCM server scripts must be modified to notify Unified ICM of call state transitions.

This section describes the ACD configuration adjustments necessary for the Aura Contact Center to work with Unified ICM. It also provides guidelines that will help you maintain your Aura Contact Center and Unified ICM configurations.

## 2.1. Configuration Prerequisites

Contact Avaya to make sure you have all the latest hot-fixes and patches for your ACD and for your particular country. Cisco cannot provide this information. Without the appropriate hot-fixes and patches, you may not be able to properly enable third-party call control on the ACD.

## 2.2. Script Modifications for Call Processing

You must modify your NCCM server scripts to include SEND INFO commands that notify Unified ICM when a call state transition occurs.<sup>1</sup> The SEND INFO commands are of the following form:

```
Send Info <provider_id> <message_type>, <p1>, ... ,<pn>
```

Where <provider\_id> is a value that uniquely identifies the Aura Contact Center PG to the HDX server; <message\_type> tells the PG what type of message is being sent; and <p<sub>1</sub>>, ..., <p<sub>n</sub>> are the parameters associated with the given message type.

The PG registers with the HDX server using <provider\_id>, and the same value must be used in the Send Info requests. The PG obtains this value from the following registry entry (relative to HKEY\_LOCAL\_MACHINE/SOFTWARE):

```
Cisco Systems,  
Inc./ICM/PG<xx>/PG/CurrentVersion/PIMS/pim1/SymposiumData/  
Config/HDXClientProviderID
```

This registry entry is set from the Client Provider ID in the HDX Link Configuration section of the “Aura Contact Center Configuration” screen in Unified Web Setup Tool. (See Chapter 3 for a sample Unified Web Setup Tool screen.)

**Note:** The NCCM server scripting language does not allow SEND INFO commands to contain constants. Therefore, <provider\_id>, ... actually denotes script variables containing the needed data. The variables are global variables if their value never changes (e.g., <provider\_id> or call variables if their value differs from call to call (e.g., the CLID parameter of the “Arrived” command described in the next section).

The following subsections describe the SEND INFO commands required in your scripts (depending on which NCCM server script commands you use). For brevity only the <message\_type> and the required parameters are listed.

---

<sup>1</sup> This information is not available from the MLink or RTD interfaces

### 2.2.1. Arrived

You must put an Arrived command<sup>1</sup> in your NCCM server master script. It tells the Aura Contact Center PG that a call has arrived at the Master Script. This command may follow a GIVE RINGBACK command, but must precede all other call processing commands in the master script (see the example that follows).

The parameters (in the order specified) are:

- Aura Contact Center Route Number<sup>2</sup>.
- CLID
- DNIS
- Transfer/Conference Flag
  - 1 If this is a consult call associated with a transfer
  - 2 If this is a consult call associated with a conference
  - 0 Otherwise

Since this is slightly complicated to set up, here is an example of what the beginning of your Master Script should look like:

GIVE RINGBACK

```
/* clid_ani is a call script variable of type CLID */
clid_ani ASSIGNED CLID
```

```
/* dnis_value is a call script variable of type DNIS */
dnis_value ASSIGNED DNIS
```

```
/* route_num is a call script variable of type integer, Route20 and
Route30 are global script variables of type Route_Number. You must
have one row in the WHERE command for every Aura Contact Center
Route
with a global script variable containing the appropriate route number.
```

Note that the Aura Contact Center call intrinsic “ROUTE NUMBER” (used in the WHERE statement below) returns zero if the call being processed is an internal ACD call. For this reason, you must configure your Aura Contact Center ACD so that all of its Route numbers are greater than zero. Otherwise, the Aura Contact Center PIM will think that external ACD calls on Route number zero are internal calls and will not process them correctly \*/

WHERE ROUTE NUMBER EQUALS

---

<sup>1</sup> The term “Arrived command” means that the <message\_type> is a global script variable whose value is the character string “Arrived” (case insensitive). The term “Arrived command” is also used to mean a SEND INFO command whose <message\_type> field is “Arrived.”

<sup>2</sup> Corresponds to Unified ICM Trunk Group Number. (See Chapter 3 for a description of the Unified ICM Trunk Group Number.)

```
VALUE Route20: route_num ASSIGNED 20
VALUE Route30: route_num ASSIGNED 30
DEFAULT:      route_num ASSIGNED -1
END WHERE
/* trans_conf_flag is a call script variable of type integer */
IF ( TRANSFERRED ) THEN
    trans_conf_flag ASSIGNED 1
ELSE IF ( CONFERENCED ) THEN
    trans_conf_flag ASSIGNED 2
ELSE
    trans_conf_flag ASSIGNED 0
END IF END IF

/* Inform the PG that a call has arrived at the Master Script. GeoTel_id is
a global script variable of type integer that contains the <provider_id>
discussed above. hdx_arrived is a global script variable of type
string that contains the string "Arrived" */

SEND INFO GeoTel_id hdx_arrived, route_num, clid_ani, dnis_value,
trans_conf_flag
```

< **Begin the call processing commands of your Master Script here** >

**Note:** In some rare scenarios, it is also necessary to use the Interflowed command in the Master Script, after the Arrived command. See [Section 2.2.2](#) for details.

### 2.2.2. Interflowed

This must be the first command in every Primary Script. It tells the Aura Contact Center PG that a call has interflowed from the Master Script to a Primary Script. This determines Unified ICM service (NCCM server application) to which the call is assigned. Since the NCCM server application for a call is determined by the **first** primary script to which the call is directed, Unified ICM ignores all interflowed messages for a call after the first one.

The parameter is:

- **Service Name.** The name of the service associated with the primary script.

Do not use the following Aura Contact Center ACD script commands in the Master Script: QUEUE TO SKILLSET, QUEUE TO AGENT, QUEUE TO NACD, and ROUTE CALL. They should be used in Primary or Secondary scripts.

If you use one of these commands in the Master Script, you need put an Interflowed command in the Master Script immediately following the Arrived command.

The Service Name parameter of the Interflowed command must be a global variable whose value is "Master\_Script."

### 2.2.3. Enqueued

This command must immediately follow every QUEUE TO SKILLSET NCCM server script command and every QUEUE TO SKILLSET BY LONGEST IDLE AGENT script command. (Also see the “Enqueued\_MLA” sections that follow.) The parameters are:

- **Priority** (a number from 1 to 6). This is the same as the number specified in the WITH PRIORITY clause of the QUEUE... script command. If there is no such clause, specify 6.
- **Skillset name(s)**. From 1 to 8 skillset names.<sup>1</sup> Note that if the QUEUE... script command specifies more than 8 skillsets, you must use multiple Enqueued commands.

### 2.2.4. Enqueued\_MLA

This command must immediately follow every QUEUE TO SKILLSET MOST LOGGED AGENTS<sup>2</sup> script command that specifies less than 9 skill groups.

The parameters are:

- **Priority** (a number from 1 to 6). This is the same as the number specified in the WITH PRIORITY clause of the QUEUE TO SKILLSET MOST LOGGED AGENTS script command. If there is no such clause, specify 6.
- **Skillset name(s)**. From 1 to 8 skillset names. Note that if the QUEUE command specifies more than 8 skillsets, you must use the Enqueued\_MLA\_Begin, Enqueued\_MLA\_Next and Enqueued\_MLA\_End commands, which are described in the next section.

### 2.2.5. Enqueued\_MLA\_Begin, Enqueued\_MLA\_Next, Enqueued\_MLA\_End

These commands must immediately follow every QUEUE TO SKILLSET MOST LOGGED AGENTS script command that specifies more than 8 skillsets.

---

<sup>1</sup> These are, of course, the skill set name(s) specified in the corresponding QUEUE TO SKILLSET or QUEUE TO SKILLSET BY LONGEST IDLE AGENT command

<sup>2</sup> See the *Nortel SCCS Scripting Guide* for details.

For example, the following script command:

```
QUEUE TO SKILLSET MOST LOGGED AGENTS SS1, SS2, ... , SS20
```

must be immediately followed by the following SEND INFO commands:

Enqueued\_MLA\_Begin priority, SS<sub>1</sub>, ... , SS<sub>8</sub>     **priority always required**

Enqueued\_MLA\_Next SS<sub>9</sub>, ... , SS<sub>17</sub>.

Enqueued\_MLA\_End SS<sub>18</sub>, ... , SS<sub>20</sub>             **one (and only one)  
MLA\_End message  
required**

### 2.2.6. Enqueued\_Agent

This command must immediately follow every QUEUE TO AGENT NCCM server script command.

The parameters are:

- **Priority** (a number from 1 to 6). This is the same as the number specified in the WITH PRIORITY clause of the QUEUE TO AGENT script command. If there is no such clause, specify 6.
- **Agent ID(s)**. From 1 to 8 agent IDs. Note that if the QUEUE TO AGENT command specifies more than 8 agent IDs, you must use multiple Enqueued\_Agent commands.

### 2.2.7. Dequeued

This command must immediately follow every REMOVE FROM SKILLSET NCCM server script command.

The parameter is:

- **Skillset name(s)**. From 1 to 8 skillset names. Note that if the REMOVE FROM SKILLSET command specifies more than 8 skillsets, you must use multiple Dequeued commands.

### 2.2.8. Dequeued\_Agent

This command must immediately follow every REMOVE FROM AGENT NCCM server script command.

The parameters are:

- **Agent ID(s)**. From 1 to 8 agent IDs. Note that if the REMOVE FROM AGENT command specifies more than 8 agent IDs, you must use multiple Enqueued\_Agent commands.

### 2.2.9. NACD\_Queued

You should avoid using QUEUE TO NACD commands in your NCCM server scripts.

(See “General Restrictions” in Chapter 1 and “Handling of QUEUE TO NACD Script Command” in Chapter 5 for more information on the use of the NACD\_Queued command.)

If you are unable to avoid using QUEUE TO NACD, you must put an HDX NACD\_Queued command immediately after every such use. In addition, you must also use the HDX NACD\_Ping command as described in the next section.

The parameter is:

- **ACD DN.** The ACD DN specified in the QUEUE TO NACD script command.

### 2.2.10. NACD\_Ping

This command must appear in every script in which you have put one or more QUEUE TO NACD script commands. There are no parameters.

When a QUEUE TO NACD command is executed during call processing, the call may be answered off-switch<sup>1</sup>. NCCM server does not inform the Aura Contact Center PG when the call is answered off-switch. The purpose of the HDX NACD\_Ping command is to inform the PG that the call has not yet been answered off-switch. (See “Handling of QUEUE TO NACD Script Command” in Chapter 5 for more information.)

If a script contains one or more QUEUE TO NACD script commands, you must put the following section in that script:

```
SECTION PING_LOOP
```

```
SEND INFO GeoTel_id hdx_nacd_ping
```

```
WAIT N
```

```
EXECUTE PING_LOOP
```

where hdx\_nacd\_ping is a global call variable containing the string NACD\_Ping, and where N is equal to one half of the value stored in the following registry entry (relative to HKEY\_LOCAL\_MACHINE/SOFTWARE):

```
Cisco Systems,
Inc./ICM/PG<xx>/PG/CurrentVersion/PIMS/pim1/SymposiumData/
Dynamic/QueueToNACDWaitTimeout
```

You must ensure that this section gets executed for any call whose processing includes a QUEUE TO NACD command. Since the section PING\_LOOP is an infinite loop that will only end when the call is answered, you must set up your script so that all other script commands for the call are executed before you enter the PING\_LOOP section.

---

<sup>1</sup> In which case, SCCS will not send the Symposium PG any more messages about the call.

You must also ensure that PING\_LOOP is entered no more than N seconds after the first QUEUE TO NACD command for the call was executed. Here is a simple example:

```
QUEUE TO NACD 5072
SEND INFO GeoTel_id hdx_nacd_queued, nacd_5072
QUEUE TO NACD 5111
SEND INFO GeoTel_id hdx_nacd_queued, nacd_5111
EXECUTE PING_LOOP
```

Where nacd\_5072 and nacd\_5111 are global script variables containing the strings 5072 and 5111 respectively.

### 2.2.11. NACD\_Dequeued

This command must immediately follow every REMOVE FROM NACD NCCM server script command.

The parameter is:

- **ACD DN.** The ACD DN specified in the REMOVE FROM NACD script command.

### 2.2.12. Routed

Unlike most of the commands in this chapter, this command must immediately **precede** every ROUTE CALL NCCM server script command<sup>1</sup>. There are restrictions on your use of the ROUTE CALL command (see “General Restrictions” in Chapter 1 for more information).

The command takes zero to two parameters. These are:

- **“controlled”**<sup>2</sup> if ROUTE CALL CONTROLLED was executed. In this case, a Controlled\_Returned SEND INFO script command must immediately follow the ROUTE CALL script command. (See “Controlled\_Returned,” later in this chapter.)

---

<sup>1</sup> The ROUTE CALL, GIVE BUSY, GIVE OVERFLOW, and DISCONNECT commands normally terminate SCCS script processing for the call, so the SEND INFO command would not be processed if it followed one of them.

<sup>2</sup> That is a global script variable of type string whose value is “controlled.”

- **“local”** if ROUTE CALL XXXX or ROUTE CALL XXXX CONTROLLED was executed, where XXXX is a number local to the NCCM server system. For example if 5100 is an ACD queue on the NCCM server system then,  
ROUTE CALL 5100  
must be followed by  
SEND INFO GeoTel\_id hdx\_routed, local\_str  
where hdx\_routed and local\_str are global call variables containing the strings “Routed” and “Local” respectively.
- Otherwise, there are no parameters.

### 2.2.13. Give\_Busy

Unlike most of the commands in this chapter, this command must immediately **precede** every GIVE BUSY NCCM server script command<sup>1</sup>.

The parameter is:

- **“controlled”** if GIVE BUSY CONTROLLED was executed. In this case, a Controlled\_Returned SEND INFO script command must immediately follow the GIVE BUSY script command. (See “Controlled\_Returned,” later in this chapter.)
- Otherwise, there are no parameters.

---

<sup>1</sup> The ROUTE CALL, GIVE BUSY, GIVE OVERFLOW, and DISCONNECT commands normally terminate SCCS script processing for the call, so the SEND INFO command would not be processed if it followed one of them.

#### 2.2.14. Give\_Overflow

Unlike most of the commands in this chapter, this command must immediately **precede** every GIVE OVERFLOW NCCM server script command<sup>1</sup>.

The parameter is:

- **“controlled”** if GIVE OVERFLOW CONTROLLED was executed. In this case, a Controlled\_Returned SEND INFO script command must immediately follow the GIVE OVERFLOW script command. (See the next section, “Controlled\_Returned.”)
- Otherwise, there are no parameters.

#### 2.2.15. Controlled\_Returned

This command must immediately follow every ROUTE CALL CONTROLLED, GIVE BUSY CONTROLLED, and GIVE OVERFLOW CONTROLLED script command.

There are no parameters.

#### 2.2.16. Disconnect

Unlike most of the commands in this chapter, this command must immediately **precede** every DISCONNECT NCCM server script command<sup>2</sup>.

There are no parameters.

### 2.3. Script Modifications for Post-Routing

You must also modify your NCCM server Script to implement post routing of calls. This is discussed in Chapter 4, “Post-Routing.”

### 2.4. Meridian 1 Configuration

In order for the PG to properly attribute calls to Unified ICM routes and services, you need to ensure that the following conditions are met.

---

<sup>1</sup> The ROUTE CALL, GIVE BUSY, GIVE OVERFLOW, and DISCONNECT commands normally terminate SCCS script processing for the call, so the SEND INFO command would not be processed if it followed one of them.

<sup>2</sup> The ROUTE CALL, GIVE BUSY, GIVE OVERFLOW, and DISCONNECT commands normally terminate SCCS script processing for the call, so the SEND INFO command would not be processed if it followed one of them.

- **Routes must have DNIS enabled.** The Aura Contact Center routes (trunk groups) on which the calls arrive must have DNIS enabled. You **must not** configure a Route Number of zero (0).
- **IAPG not used.** The IAPG parameter **is not used** for Aura Contact Center. Therefore, it does not matter what value is set in that field.
- **Set ISAP=NO (default).** If ACD DN's must be configured, set ISAP to YES. If DN's in ACD queue must be configured, set ISAP to NO.
- **ACD positions configured as AST.** All ACD positions must be configured as AST. This is done in LD 10 and LD 11. For BCS sets that contain both an ACD position and an IDN, you must configure both keys as AST in LD 11.
 

**Note:** Due to limitations in the Avaya Aura Contact Center Link interface, the Aura Contact Center PIM can only monitor two lines on a phone set. If you configure more than two lines on a phone set, Unified ICM software will not be able to track calls on the additional lines.
- **Aura Contact Center Route Numbers must be greater than zero.** The Aura Contact Center PIM requires that all Aura Contact Center Route Numbers be greater than zero.
- **Security (SECU) for ELAN.** You need to set the security (SECU) for the ELAN to YES in LD 17.
 

**Note:** As a part of your PBX maintenance, if you are attempting a service change by deleting or reconfiguring a device, ensure that the intended device is not involved in an active call of any state (connected, ringing and hold), and the corresponding agent is logged off.

## 2.5. IVR Port Configuration and Considerations

To configure IVR Voice ports as ACD agents belonging to IVR ACD-DN in Avaya PBX platforms:

- Configure the line side T1/E1 ports that are programmed as single line phones on the PBX as ACD phones. That is, CLS=AGTA, AACD=YES, AST=yes
- Program and acquire agents in Aura Contact Center according to Avaya documentation, as you would with real agents.

## 2.6. Meridian Mail Considerations

Meridian mail ports are configured as ACD agents belonging to an ACD-DN in Avaya PBX platforms.

Program and acquire agents in Aura Contact Center according to Avaya documentation.

- Note:** Use of the term *Meridian Mail* is confusing, and is often considered in lines with the IVR. However, the difference is that, IVR usually front-ends calls and transfers **to** the Aura Contact Center. The use of *Meridian*

*Mail* is when the call has arrived **in** the Aura Contact Center and gives treatments such as play announcements, menus, etc. It may not be required to track all individual call treatments.

In the example that follows, observe that the commands “Open Voice Session” and “GIVE IVR interruptible 2999...” are both within the Aura Contact Center script, and are both Meridian Mail treatments even though one command says to GIVE IVR.

For example, in Aura Contact Center, you can program the scripts as follows:

```
SEND INFO GeoTel_ID hdx_enqueued, PriorityValue, Skill_SpareParts
```

```
OPEN Voice Session 2998
    Play Prompt Voice Segment Y2KOrLonely
    END Voice Session
```

```
Wait 1
GIVE MUSIC 3
Wait 5
```

```
GIVE IVR interruptible 2999 with treatment 299901
Wait 5
```

```
GIVE IVR interruptible 2999 with treatment 299903
Wait 5
```

```
GIVE IVR interruptible 2999 with treatment 299904
Wait 5
```

```
EXECUTE EndlessLoop
```

```
Section EndlessLoop
IF (LOGGED AGENT COUNT SpareParts < 1) OR
    (TIME OF DAY <> 8:00.18:00)
    THEN EXECUTE Afterhours
    ELSE
GIVE IVR interruptible 2999 with treatment 299905
END IF
Wait 30
```

```
EXECUTE Endless Loop
```

## 2.7. NCCM Server Capacity Considerations

You must ensure that your Aura Contact Center system has the capacity to handle the message and CPU load you expect. See the following Avaya publications for NCCM server capacity guidelines:

- *Aura Contact Center Server Capacity Assessment Tool User Guide*
- *Aura Contact Center Server Planning and Engineering Guide*

---

## 3. Web Setup Tool and Configuration

The Web Setup Tool is used to install Unified ICM software components such as the Aura Contact Center PG software. A separate suite of Unified ICM software configuration tools is used to configure the Aura Contact Center PG. This chapter provides information specific to setting up an Aura Contact Center PG by using the Web Setup Tool. It also provides information specific to configuring an Aura Contact Center PG by using the Unified ICM configuration tools.

*See also:* For specific information on using Web Setup Tool, see the *Cisco Unified Contact Center Enterprise Installation and Upgrade Guide*. For specific information on using the Unified ICM software configuration tools, see the *Configuration Guide for Cisco Unified ICM Enterprise*.

### 3.1. Web Setup Tool

Before you use Web Setup Tool to install the Aura Contact Center PG, you must first create a peripheral object for the PG by using the Unified ICM Software configuration tools. Specifically, use Configure Unified ICM software or the newer PG Explorer tool (available in ICM 4.5 and greater) to configure a peripheral object for the PG.

Write down the Peripheral Number and Logical Controller ID values that Unified ICM assigns to the peripheral object. You will need these values when you install the PG through the Web Setup Tool.

*See also:* For more information on configuring peripheral objects, see “Unified Configuration” later in this chapter. For detailed instructions, see the *Installation Guide for Cisco Unified ICM/Contact Center Enterprise & Hosted*.

#### 3.1.1. Installing the Aura Contact Center PG

Follow the instructions for installing the Aura Contact Center PG that are outlined in the *Cisco Unified Contact Center Enterprise Installation and Upgrade Guide*. Use the detailed field descriptions provided in this chapter as supplementary information, if necessary.

Within the Web Setup Tool, one of the following dialog boxes is displayed, depending on which version of Unified ICM you are running:

**Figure 4: Unified Web Setup Tool 4.5, SP1 onward  
(for Symposium ACD 1.5, 3.0, or 4.0/4.2)**

Make the following settings in the Aura Contact Center Configuration screen:

- **Peripheral Name.** Set this field to the name by which you identify the Aura Contact Center ACD.

- **Peripheral ID.** Set this field to the integer identifier for the peripheral (ACD) from the Peripheral table of the Unified ICM database. This is the value you obtained when you created a Peripheral object for the Aura Contact Center PG in Configure Unified ICM (or the newer PG Explorer tool.)
- **NCCM server Host.** Set the NCCM server Host Name to the IP name or IP address of your NCCM server. Note that if you use a name it must be in the “hosts” file used by the PG.

**Note:** The PIM becomes active when the three interfaces – Meridian Link Interface (MLink), Host Data Exchange Interface (HDX) and Real Time Data Interface (RTD) register with the PIM. Once it becomes active, the PIM tries to additionally register the Position IDs, Individual Directory Number (IDN) and Controlled DN (DN) using the DNREG command.

If the register response (DNREGR) shows that the registrations failed because of bad Resource IDs, it indicates that configuration of position Ids, IDNs or CDNs for which the error was seen on the ACD side do not match with those on the Unified ICM. That is, the configuration numbers on the NCCM server instances should match with those on the Unified ICM.

### 3.1.2. Meridian Link Configuration

Make the following settings in the Meridian Link Configuration section:

- **Link Host Name.** Set the Link Host Name to the host name configured in the link 1 configuration file on the NCCM server system. This defaults to “Lanlink,” and normally you must not change it.
- **Server port.** Set the Server port field to the well-known port used by Meridian Link. The Meridian Link server and Web Setup Tool both default this value to 3000.
- **Link Machine.** Set the Link Machine field to the Meridian 1 Machine name in the link 0 configuration file on the NCCM server system. This defaults to “SL16” and normally you must not change it.
- **Instance Number.** Set the Instance Number field to the customer number on the Meridian 1 for which this PG will route calls. This defaults to 0.

### 3.1.3. RTD Configuration

Make the following settings in the RTD Link Configuration section:

- **Client Login.** Set the Client Login field to the user name you have set up on the NCCM server system for RTD requestors. The default is “sysadmin.”
- **Client Password.** Set the Client Password field to the password for that user. The default is “nortel.”

### 3.1.4. HDX Configuration

Make the following settings in the HDX Link Configuration section:

- **Client Host Name.** Set the Client Host Name field to the IP name or address of the machine on which the Aura Contact Center PG will run. Note that if you use a name it must be in the “hosts” file used by the PG. Also note that if you are running a duplexed PG, you will, of course, store different values in this field for side A and side B.<sup>1</sup>
- **Client Provider ID.** Set the Client Provider ID to the ID by which the PG will identify itself to the HDX server. The default for this field is 64206. Normally you must not change this default. You must use this provider id in all of the SEND INFO and SEND REQUEST commands that you put in your NCCM server script. See Chapter 2, “ACD Configuration,” for more information on NCCM server script modifications.
- **Client Instance.** Set the Client Instance String field to the string that you want the PG to send to the HDX server as the instance string. The default for this field is “Cisco Aura Contact Center PIM.” Normally, you must not change this default.

## 3.2. Unified ICM Software Configuration

In order to properly configure and maintain the Unified ICM database, you need to understand the relationships between the Aura Contact Center database objects and the Unified ICM database objects. For example, *skill groups* correspond to Aura Contact Center *skill sets*, and *services* correspond to Aura Contact Center *applications*. By understanding the relationships between the Aura Contact Center and Unified ICM database objects, it will be easier to keep the Aura Contact Center and Unified ICM databases synchronized (that is, up-to-date with each other).

This section describes the relationships between the Aura Contact Center and the Unified ICM database objects. It also provides information you can use to configure an Aura Contact Center PG by using the Unified ICM software configuration tools. Use the information in this section as a supplement to the information contained in the *Cisco Unified Contact Center Enterprise Installation and Upgrade Guide*.

---

<sup>1</sup> The IP name or address of the machines running side A and side B respectively

**Note:** In earlier releases of Unified ICM, the Configure ICM software tool was used to configure objects in the Unified ICM database. In Unified ICM 4.5 and beyond, a new set of configuration tools are available. In Unified ICM 4.5 and greater, use the Unified ICM Software Configuration Manager to start the appropriate configuration tool (For example, the PG Explorer tool).

### 3.2.1. Peripheral Configuration

In Unified ICM terms, the Aura Contact Center ACD itself corresponds to a *peripheral*. Unified ICM treats all contact center devices (e.g., ACDs, PBXs, IVR systems) as peripherals.

Depending on the version of Unified ICM you are running, use either Configure Unified ICM software or the PG Explorer to create a peripheral.

Be sure to set the **Available Holdoff Delay** option to zero.

Agent real time data on Aura Contact Center will work only if **Enable Agent Reporting** and therefore **Auto Configure** are checked.

**Note:** Aura Contact Center PG does not support auto-configuration of agents. Since Agent auto-configuration and Agent reporting are mutually inclusive in the Peripheral configuration screen, the following work around needs to be performed for Agent reporting to work without the call router performing the actual agent configuration. On the callrouters' registry, go to

HKey\_Local\_Machine/Software/Cisco Systems,  
Inc./ICM/IRS/RouterA/Router/CurrentVersion/Configuration/AutoConfig

Set the value for AgentEnabled to 0. This implies that the call router will not perform agent auto-configuration even though auto-configuration is turned on. Note that the agents will have to be manually configured even though auto-configuration is turned on.

### 3.2.2. Peripheral Target Configuration

A Unified ICM *Peripheral Target* is a network target identified by a Network Trunk Group and DNIS that terminates on the Meridian ACD.

You must configure a Unified ICM Software Peripheral Target for every DNIS and Network Trunk Group combination through which incoming ACD calls arrive. You must also configure Peripheral Targets for translation routing.

Depending on the version of Unified ICM you are running, use either Configure Unified ICM or the Peripheral Target Bulk tools to create a peripheral target.

*See also:* For more information on Translation Routing and Peripheral Targets, see Chapter 4, "Post-Routing."

Note that the Aura Contact Center ACD supports configurations in which multiple IDC (incoming digit conversion) tables are used to map a single DNIS value to different Aura Contact Center CDNs depending on which Aura Contact Center Route (Unified ICM software Peripheral Trunk Group) the call arrives. If you use this feature, you must be careful when configuring Network Trunk Groups and Peripheral Targets in Unified ICM. In particular, when you configure a Network Trunk Group you must ensure that all of the Peripheral Trunk Groups in that Network Trunk Group map a given DNIS value to the same Aura Contact Center CDN.<sup>1</sup> Therefore, if you are using multiple IDC tables you must create a separate Network Trunk Group for each of these tables. You must then create Peripheral Targets to correspond to each of these network trunk groups.

For Unified ICM Software Route statistics, the PG attributes calls to Unified ICM Software Routes by looking for a Peripheral Target that matches the Trunk Group and DNIS for the call. If it finds one, it uses the route associated with that Peripheral Target. Otherwise, it looks for *any* Peripheral Target that matches the DNIS for the call and uses the associated route.<sup>2</sup> Finally, if it finds no matching Peripheral Target it attributes the call to the default route for the peripheral (if one is configured). If there is none, Unified ICM will not gather route or service data for the call.

### 3.2.3. Trunk Group Configuration

A Unified ICM *Trunk Group* is equivalent to an Aura Contact Center *Route*. The Aura Contact Center PG requires that you configure the Aura Contact Center ACD so that all Aura Contact Center Route Numbers are greater than zero.

Depending on the version of Unified ICM you are running, use either Configure Unified ICM software or the Network Trunk Group – Trunk Group Explorer tool to configure trunk groups.

Configure a Unified ICM software Trunk Group for each Aura Contact Center route on which ACD calls arrive. Set the Unified ICM Software Peripheral Number to the Aura Contact Center Route Number. Leave the Unified ICM Software Trunk Count at the default value “Use Trunk Data.” Set the Unified ICM Software Trunk Group **Extension** to the Aura Contact Center route access code (ACOD) for the route.

---

<sup>1</sup> Example: Let D be a DNIS value. Suppose network trunk group X consists of peripheral trunk groups K, L, and M. Then (K, D), (L, D) and (M,D) all refer to the same software peripheral target so it is nonsensical to have K, L and M map D to different Symposium CDNs.

<sup>2</sup> You can cause the PG to bypass this step by setting the following registry variable to zero:  
HKEY\_LOCAL\_MACHINE/SOFTWARE/Cisco/ICM/PG<XX>/PG/CurrentVersion/OPC/CallControl/MapPeripheralTargetsWithoutTrunkGroup

### 3.2.4. Trunk Configuration

The Aura Contact Center PG does not monitor individual trunks. Therefore, you don't need to configure individual Unified ICM trunks for Aura Contact Center ACDs.

### 3.2.5. Service Configuration

A Unified ICM *service* is equivalent to an Aura Contact Center *application*.

Depending on the version of Unified ICM you are running, use either Configure Unified ICM software or the Service Explorer tool to create a service.

You must store the name of the corresponding Aura Contact Center application in the Unified ICM software service's **ConfigParam** field. Each application must have a unique Unified ICM peripheral number. You may set the value of this field to any value you desire as long as it is unique.

The Aura Contact Center PG does not use the **Extension** field. The "Peripheral Service Level Type" setting has no effect since the Aura Contact Center PG does not report a peripheral service level (although it does report a Unified ICM software service level).

**Important:** You must configure Unified ICM software service with the name, "Master\_Script." The **ConfigParam** field of this service must also be "Master\_Script." You need to configure this service before attempting to start the PIM. If you do not configure the Master\_Script service, the PIM will not start and errors will be logged to the PIM log.

**Note:** On an Aura Contact Center PG, ensure that:

- The services are properly configured with the corresponding routes and network trunk groups.
- The peripheral name and the configuration parameter of each service should be the same as the service name on SCCS.

Failure to meet these conditions may result in unexpected behavior of Agent desktops and Call routing.

### 3.2.6. Skill Group Configuration

A Unified ICM *skill group* is equivalent to an Aura Contact Center *skill set*.

Depending on the version of Unified ICM you are running, use either Configure Unified ICM software or the Skill Group Explorer tool in the Unified ICM Software Configuration Manager to configure skill groups.

You must store the name of the corresponding Aura Contact Center skill set in the Unified ICM skill group's **ConfigParam** field. (To avoid confusion, you should also use this name as the name of the Unified ICM skill group, but this is not required.) Each skill group must have a unique Unified ICM Software Peripheral Number. You may set the value of this field to any value you desire as long as it is unique.

A Aura Contact Center agent is a member of one or more skill sets. For each of these skill sets the agent is assigned a priority from 1 to 48 by the NCCM server administrator. Use **SS** as the Aura Contact Center skill set and **SG** as the corresponding Unified ICM software skill group.

Unified ICM configuration for **SG** must contain a sub-group for every priority level at which some agent is a member of **SS**. For example, if agent A is a member of **SS** at priority 1 and agent B is a member of **SS** at priority 5, and no other agents belong to **SS**, then **SG** must be configured with subgroups 1 and 5.

The Aura Contact Center PG does not use the **Extension** field.

The **Available Holdoff Delay** option should be set to zero.

**Note:** The skill group name is case sensitive. Ensure that it is the same as the skillset name configured in Aura Contact Center.

**Important:** You must configure a Unified ICM skill group with the name, “Unconfigured\_Agents.”<sup>1</sup> The **ConfigParam** field of this skill group must also be “Unconfigured\_Agents.” The PG will attribute calls to this skill group for any NCCM server agent who does not appear in Unified ICM configuration.<sup>2</sup> You need to configure this skill group before attempting to start the PIM. If you do not configure the Unconfigured\_Agents skill group, the PIM will not start and errors will be logged to the PIM log.

### **Calls Queued to Agents**

On the Aura Contact Center PIM, after a call that was queued to an agent has been answered by the agent, there is about a 15-20 second delay before third-party control is established.

Although the voice path happens without any delay, to suppress the delay that happens at any third-party control at the agent-side, add a skill group called **Agent\_Queued\_To** on Unified ICM. Ensure that you set the configuration parameter to “Agent Queued To.” Assign this skill group to those agents to whom the calls are queued.

## **3.2.7. Service Member Mappings**

No special configuration consideration required.

## **3.2.8. Agent Configuration**

A Unified ICM *agent* is equivalent to an Aura Contact Center *agent*.

---

<sup>1</sup> Even if Unified ICM is integrated with the Automated Administrator for Symposium (AAS), you need to configure the software skill group name as “Unconfigured Agents”. AAS will **not** configure the “Unconfigured Agents” skill group. For the Symposium PIM to become active, you will need to do the configuration manually.

<sup>2</sup> Thus, if you see calls being attributed to this skill group you will know that you have not configured all of your SCCS agents.

Depending on the version of Unified ICM you are running, use either Configure Unified ICM Software or the Agent Route Explorer tools to configure agents. You must enter every Aura Contact Center agent into Unified ICM configuration. Set the Unified ICM Software Agent Peripheral Number to the Aura Contact Center Agent ID.

- Note 1:** The ACD positions used by agents (known to Unified ICM) have to be configured as AST. If an agent moves to another location, the new ACD position also has to be configured as AST and equipped with an AST license.
- Note 2:** When you delete an agent in Unified ICM, ensure that the agent is permanently deleted. Before deleting, the agent must be logged off from Unified ICM.

### 3.2.9. Agent State Mapping

Table 2 defines the mapping between Aura Contact Center agent states and Unified ICM agent states.

**Table 2: Aura Contact Center-to-Unified ICM Agent State Mapping**

Aura Contact Center Agent State	Unified ICM Software Agent State
Not Ready Walkaway	Not Ready
Emergency	Not Ready
Not Ready	Work Ready
Break	Work Ready
Busy	Work Ready
Idle	Available
Call Presented	Reserved
Active	Talking
Consultation	Talking
On Hold	Hold
On Hold Walkaway	Hold

### 3.2.10. Skill Group Member Mappings

You must configure the skill groups to which an agent belongs (and the agent’s priority within each skill group) in Unified ICM skill group member table. Now, with the AAS option (Automated Administrator for Aura Contact Center), it is possible for Agent to Skill group mappings to be done automatically. For details, refer to Chapter 7, SEI Lite Interface with Avaya Aura Contact Center.

- Note:** When you change agent to skill group mapping, Unified ICM services need not be restarted. For example, if you re-assign an agent to another skill group or remove an agent from a skill group, it is not required to restart Unified ICM Service.

### 3.2.11. Translation Routes

The Aura Contact Center PG supports Translation Routes. See Chapter 4, “Post-Routing” for more information on Translation Routes.

### 3.2.12. Route Configuration

A Unified ICM *route* is one or more Unified ICM software peripheral targets. A Unified ICM peripheral target is a network target identified by a network trunk group and DNIS that terminates on the Aura Contact Center ACD. A peripheral target is equivalent to the combination of DNIS and the (network) trunk group(s) through which incoming ACD calls arrive.

Depending on the version of Unified ICM you are running, use either Configure ICM software or the Route Bulk tools to configure routes.

No special configuration consideration required.

### 3.2.13. Routing Client Configuration

The Aura Contact Center PG supports post-routing. The Aura Contact Center PG routing client is active whenever the PG itself is active.

Depending on the version of Unified ICM you are running, use either Configure ICM software or the PG Explorer tool to configure a routing client.

Enable post-routing for the Aura Contact Center PG. You must also configure appropriate Unified ICM dialed numbers and labels for use with post-routing. See Chapter 4, “[Post-Routing](#)” for more information.

No special configuration consideration required.

### 3.2.14. Peripheral Monitor Configuration of Aura Contact Center CDNs

You must configure all of your Aura Contact Center CDNs in the Unified ICM Software Peripheral Monitor table. This is required so that the PG can register with Meridian Link to receive events for these CDNs. The Aura Contact Center PG will not be able to track calls directed to any Aura Contact Center CDN that you have not configured.

Depending on the version of Unified ICM you are running, use either Configure ICM software or the PG Explorer tool to configure Aura Contact Center CDNs in the Peripheral Monitor table.

In addition, you must separately configure each Aura Contact Center CDN by creating a Peripheral Monitor table entry whose Type field is “Aura Contact Center CDN” and whose “Param String” field is the CDN number. The PG does not currently use the **Extension** field.

### 3.2.15. Peripheral Monitor Configuration of Aura Contact Center Positions

You must configure all of your ACD positions and their corresponding IDNs in the Unified ICM Software Peripheral Monitor table. This is required so that the PG can register with Meridian Link to receive events

for these positions. It also allows the PG to associate IDNs with their corresponding position ID values. If you don't configure all of your positions correctly you may experience difficulty monitoring data and using Enterprise CTL.

Depending on the version of Unified ICM you are running, use either Configure ICM software or the PG Explorer to configure ACD positions and IDNs in the Peripheral Monitor table.

You configure position IDs and IDNs by creating one or more Peripheral Monitor table entries whose Type field is "Meridian Position" and whose "Param String" field is described in the following paragraph. The PG does not currently use the **Extension** field.

You can use the Param String field to specify a single Aura Contact Center position, a range of positions, a single Aura Contact Center position and IDN pair, or a range of positions and IDN pairs (see Table 3). In Table 3, a dash indicates a range. A comma indicates that what follows is an IDN specification.

**Table 3: Param String Format Examples**

Param String Format	Example	Meaning
Position ID	5201	Indicates a single position "5201" with no associated IDN
Position ID, IDN	5201,4201	Indicates a single position "5201" with associated IDN "4201"
Position ID Range	5201-5299	Indicates a range of positions from "5201" up to "5299." None of these positions have associated IDN keys.
Position ID Range, IDN Range	5201-5299,4201-4299	Indicates a range of positions from "5201" up to "5299." Position 5201 is associated with IDN 4201. Position 5202 is associated with IDN 4202, etc.

If your position ID and IDN values are arranged in sequence, you can reduce the number of entries required in the Peripheral Monitor table by specifying ranges of positions. Note that the maximum range the PG allows is 200 positions.

If you have ranges that span more than 200 positions, you must enter them as multiple contiguous ranges in separate Peripheral Monitor table entries. For proper monitoring of Aura Contact Center positions and CDNs, please note the following:

- Do not add duplicate entries in the Peripheral Monitor table. This leads to the corruption of the table.
- You cannot change the Peripheral Monitor type from Meridian position to CDN and vice versa if the configuration parameters remain the same.

### 3.3. IVR Port Configurations

To configure the IVR Port in Unified ICM, add the ACD single line sets/IVR ports in the Peripheral Monitor table just as we would, the position ID and DN of a real agent. That is, set CLS =AGTA, AACD=YES, AST=yes

For information regarding adding agents to the Unified ICM Software Peripheral Monitor Table, refer to the section 3.2.15, \_ Monitor Configuration of Aura Contact Center Positions.

By monitoring these IVR ports, using either Meridian MAX/Link or Aura Contact Center, you can track all incoming calls from the trunk entry into the PBX, through ACD call modifications (IVR ports) and eventually to Aura Contact Center scripts and real agent/skillset queuing.

**Note 1:** For old MAX/Link platforms, remember to turn on RPRT=yes in ACDDN block and IAPG=yes in the phone overlay in addition to setting CLS =AGTA, AACD=YES, AST=yes.

**Note 2:** On the side of Unified ICM, Meridian mail ports need not be configured at the Peripheral Monitor table.

### 3.4. Activity Code Configuration

To configure Activity codes in Unified ICM, define the following:

#### 3.4.1. Unified ICM Configuration

In the PG Explorer tool, Peripheral tab, define the configuration parameter as /nrc xxx, where xxx is the default activity code.

#### 3.4.2. \_CTI OS Server Configuration

Make the following registry settings in the CTI OS server:

- [HKEY\_LOCAL\_MACHINE]\SOFTWARE\Cisco Systems\CTIOS\Server\Agent\<NotReadyReasonRequired>  
Specify the value of *NotReadyReasonRequired* as 1.
- [HKEY\_LOCAL\_MACHINE]\SOFTWARE\Cisco Systems\CTIOS\Server\Agent\ReasonCodes\NotReady\<Not ready reason code>  
Specify *Not ready reason code* as 1.

#### 3.4.3. Meridian PBX and SCCS Configuration

You need to configure Activity codes for the following:

- Agent sets on Meridian
- SCCS

### 3.5. Special Considerations in NAM Environments

In a Network Applications Manager (NAM) environment, multiple Customer ICM software systems (CICMs) can share the same ACD. If you are a NAM customer and you want to filter out events for ACD agents that are not monitored by your CICM system, then you have to set the LoginUnconfiguredAgents registry key to 1.

➤ **To change the LoginUnconfiguredAgents registry key:**

1. From the Start menu, click Run.
2. Type regedit to open the registry.
3. Create the following registry data field (REG\_DWORD) if it does not already exist:

```
SOFTWARE\Cisco Systems,
Inc.\...\pgXX\PG\CurrentVersion\PIMS\pimY\
SymposiumData\Dynamic>LoginUnconfiguredAgents
```

4. Set the value of this field to 1.

In non-NAM Unified ICM configurations, this field is set to 0 by default.

### 3.6. Maintaining Your Configuration

It is important to keep your Unified ICM configuration up-to-date when you make NCCM server configuration changes. The following types of NCCM server changes need to be reflected in Unified ICM configuration:

- Addition of a new application.
- Addition of a new skill set. Do not forget to configure sub-groups to reflect all of the priorities at which agents will be members of this skill set.
- Addition of a new agent. For every skill set SS to which the agent belongs, you must also add an entry to the skill group member table for the skill group that corresponds to SS. If the agent's priority, call it X, in a skill set SS is different from the priority in SS of any previously configured agent, you must create a new sub group for X in Unified ICM skill group that corresponds to SS.

**Note:** When the AAS option is in use, new skills and agents will be added automatically, but the skill group and agent names will be created with defaults, and manual updates within Unified ICM configuration are necessary to give appropriately descriptive names. For details, refer to Chapter 7, SEI Lite Interface with Avaya Aura Contact Center.

- Addition of a new Aura Contact Center route.

- Changes to Aura Contact Center CDNs must be reflected in your Unified ICM Software Peripheral Monitor table.
- Changes to ACD positions and IDNs must be reflected in your Unified ICM Software Peripheral Monitor table.

## 4. Post-Routing

This chapter describes the changes you must make to Unified ICM configuration, NCCM server configuration, and the NCCM server scripts to be able to post-route calls using the Aura Contact Center PG. It also discusses any considerations you should be aware of when using Post-Routing or Translation Routing on the Aura Contact Center PG.

## 4.1. Changes to the NCCM server Configuration

This section describes the changes you need to make to your NCCM server configuration to be able to post-route calls.

**Important:** Commands related to post-routing **must** be placed in the NCCM server Master Script. If you do not do this, the post-routed call will not be attributed to the correct Unified ICM service (NCCM server application).

### 4.1.1. Reserve CDNs or DNISs

Reserve a set of CDNs or a set of DNISs or both to use for post-routing. Your Master Script must contain lines of the following form:

```
IF (CDN = XXXX .. ZZZZ) THEN
    EXECUTE DO_POST_ROUTE
END IF
```

Where XXXX .. ZZZZ is the range of CDNs you have assigned to post routing , or

```
IF (DNIS = XXXX .. ZZZZ) THEN
    EXECUTE DO_POST_ROUTE
END IF
```

Where XXXX .. ZZZZ is the range of DNISs you have assigned to post-routing, or a more complicated IF statement if you are using both CDNs and DNISs.

**Note:** For simplicity, assume for the rest of this section that you are using only CDNs for post-routing.

### 4.1.2. DO\_POST\_ROUTE Section of Master Script

In the DO\_POST\_ROUTE section of the Master Script, you must use the following three-way handshake with the Aura Contact Center PG to initiate a post-route for a call:

- SEND REQUEST script command to ask the PG to obtain information that will allow the NCCM server script to determine the target of the call.
- GET RESPONSE script command to obtain a response type and a response value from the PG that the script can then use to continue processing the call.
- SEND INFO script command to tell the PG whether or not the NCCM server script timed out while waiting for the response from the PG.

These commands have the following forms:

```
SEND REQUEST <provider_id> pr_req, <dialed_num>, <clid_ani>,
<dnis>, <in_vars>
```

Where:

- **<provider\_id>** identifies the Aura Contact Center PG (see Chapter 2 for more information on <provider\_id>).
- **pr\_req** is a global script variable whose value is the character string “Post\_Route\_Request”
- **<dialed\_num>** is Unified ICM dialed number you have associated with the post route CDN that led to this SEND REQUEST command (see below for an example)
- **<clid\_ani>** is the CLID/ANI associated with the call being post routed
- **<dnis>** is the DNIS associated with the call being post routed
- **<in\_vars>** means zero to five NCCM server script variables separated by commas. The PG will store the values of these variables into Unified ICM call variables that it will pass to the CallRouter along with the route request. You can then use these call variables in your Unified ICM routing scripts to help control how calls are processed. Which Unified ICM call variables are used is specified by the Unified ICM Call Control Variable map (see the section “[Changes to Unified ICM Software Configuration](#)”). Different SEND REQUEST commands may specify different numbers of <in\_vars>.

```
GET RESPONSE <provider_id> <status>, <type>, <value>, <out_vars>
```

Where:

- **<provider\_id>** identifies the Aura Contact Center PG (see Chapter 2 for more information on <provider\_id>).
- **<status>** indicates the result of the post route request. A value of zero indicates that the request was successful. A non-zero value indicates failure. See the example below for a complete list of the failure values and their meaning.
- **<type>** and **<value>** tell your NCCM server script how to process the call. The values that the PG returns in <type> and <value> are determined by the Unified ICM label that your Unified ICM script returns to the PG in response to the post route request. You must set up your NCCM server and Unified ICM scripts so that the <type> and <value> returned for a given post route request cause the call to be processed in the way that you want. You can make this as simple or as complex as you need. For example, in the sample script fragments below we use CDN and <type> to determine which NCCM server primary script to execute, and use <value> to determine what processing is done within each primary script.
- **<out\_vars>** means zero to five NCCM server script variables separated by commas. Your Unified ICM scripts can return Unified ICM call variables to the PG as part of the response to the route request. The PG will return the values of these variables in the NCCM

server script variables. You can then use these variables in your NCCM server scripts to help control how calls are processed. Which Unified ICM call variables are returned is specified by the Unified ICM Call Control Variable map (see the section “[Changes to the Unified ICM Software Configuration](#)”). All GET RESPONSE commands *must* specify the same number of <out vars><sup>1</sup>.

```
SEND INFO <provider_id> post_route_response_ack, <status>
```

Where:

<provider\_id> identifies the Aura Contact Center PG (see Chapter 2 for more information on <provider\_id>). **post\_route\_response\_ack** is a global script variable whose value is the character string “Post\_Route\_Response\_Ack.”

- **<status>** tells the PG whether or not the NCCM server GET RESPONSE command timed out before it received the post route response from the PG. A value of 0 indicates that it did not time out and that the NCCM server script will use the post route response. A value of 1 indicates that it did time out, and that the response will not be used.

#### 4.1.3. Example of Post-Routing Section in Master Script

The post-routing section in the Master Script should look like the example shown below. The script global variables have the following values:

Script Global Variables	Values
pr_req	“Post_Route_Request”
pr_route_response_ack	“Post_Route_Response_Ack”
pr_ok	0
pr_sccs_timeout	1
pr_dn_XXXX	<the Unified ICM software dialed number you have associated with CDN XXXX>
pr_dn_ZZZZ	<the Unified ICM software dialed number you have associated with CDN ZZZZ>

```
SECTION DO_POST_ROUTE
```

```
/* You must set this script call variable to 1 so that you can detect when the GET
RESPONSE command below times out. The Aura Contact Center PG will never return
a status value of 1 */
post_route_status ASSIGNED 1
```

```
/* Send a different dialed number to the PG depending on the CDN. The duplicate
```

<sup>1</sup> The SCCS GET RESPONSE command requires that the PG returns exactly as many values as there are variables specified in the command. Since the PG has no way of determining how many were specified in a given GET RESPONSE command, we require that all commands specify the same number (and this number is known to the PG from the call control variable map)

```

GET RESPONSE messages are necessary because the script compiler will not allow
a single GET RESPONSE to be placed at the end of the where clause */
WHERE CDN EQUALS
  VALUE XXXX:
    SEND REQUEST GeoTel_id pr_req, pr_dn_XXXX, clid_ani, dnis_value, <in vars>
    GET RESPONSE GeoTel_id post_route_status_str, type, value, <out vars>
    .
    .
    .

  VALUE ZZZZ:
    SEND REQUEST GeoTel_id pr_req, pr_dn_ZZZZ, clid_ani, dnis_value, <in vars>
    GET RESPONSE GeoTel_id post_route_status, type, value, <out vars>

END WHERE

/* If the post route request failed, go log an error, and do something with the call */
IF ( NOT (post_route_status = 0) ) THEN
  EXECUTE POST_ROUTE_FAILED
END IF
/* If we get here, the post route succeeded, so complete the three way handshake with
the Aura Contact Center PG as described above */
SEND INFO GeoTel_id post_route_response_ack, pr_ok

/* Act on the information returned by the post route request. Each of the scripts
executed below will have a "WHERE response_value EQUALS" command
that will process the call based on the response_value */
WHERE CDN EQUALS
  VALUE XXXX:
    WHERE response_type EQUALS
      VALUE 0: EXECUTE SCRIPT <script for response type 0 and CDN XXXX>
      .
      .
      .
      VALUE N_xxxx: EXECUTE SCRIPT <script for response type N_xxxx and CDN XXXX>
    DEFAULT:
      LOG "Unknown response type"
      DISCONNECT
    END WHERE
  .
  .
  .
  VALUE ZZZZ:
    WHERE response_type EQUALS
      VALUE 0: EXECUTE SCRIPT <script for response type 0 and CDN ZZZZ>
      .
      .
      .
      VALUE N_zzzz: EXECUTE SCRIPT <script for response type N_zzzz and CDN ZZZZ>
    DEFAULT:
      LOG "Unknown response type"
      DISCONNECT
    END WHERE

END WHERE

QUIT

```

```
SECTION POST_ROUTE_FAILED
WHERE post_route_status EQUALS

    /* A status value of 1 means that the GET RESPONSE script command timed out. So
    we must inform the Aura Contact Center PG that this has happened */
VALUE 1:
    SEND INFO GeoTel_id post_route_response_ack, pr_sccs_timeout
    LOG "Route Request Failed: GET RESPONSE timed out"

VALUE 2:
    LOG "Route Request Failed: ICM timed out"

VALUE 3:
    LOG "Route Request Failed: PG routing client not running"

VALUE 4:
    LOG "Route Request Failed: Dialed Number is invalid"

VALUE 5:
    LOG "Route Request Failed: Bad params - wrong number, type or length"

VALUE 6:
    LOG "Route Request Failed: Bad ICM post-route label format"

VALUE 7:
    LOG "Route Request Failed: Too many params after DNIS in SEND REQUEST"

VALUE 8:
    LOG "Route Request Failed: Request led to circular route"

VALUE 9:
    LOG "Route Request Failed: Non-numeric or negative translation route label"

VALUE 10:
    LOG "Route Request Failed" /* For some reason other than those above */

DEFAULT:
    LOG "Unknown status returned for route request"
END WHERE
```

The above WHERE command must be followed by script commands that process the call for which the post route failed.

## 4.2. Changes to the Unified ICM Software Configuration

You need to make the following changes to your Unified ICM configuration for post-routing.

### 4.2.1. Labels

The label that your Unified ICM scripts must return in response to a post-route request can have one of two forms (where X and Y are integers in the range 0 to 2147483647):

- X** When the PG receives a label of this form from the CallRouter, it will return a response value of X and a response type of zero to the GET RESPONSE command.
- Y.X** When the PG receives a label of this form from the CallRouter, it will return a response type of Y and a response value of X to the GET RESPONSE command.

You configure these labels in the normal way using the Unified ICM configuration tools.

### 4.2.2. Call Control Variable Map

Depending on your Unified ICM release, the Call Control Variable Map is configured by using the PG Explorer (4.5 and beyond). The Unified ICM Call Control Variable map for the Aura Contact Center PG is a string of the form:

```
/RREQ <ICM call variable list> /RRES <ICM call variable list>
```

where <ICM call variable list> is a list of one to five integers in the range 1-10 separated by spaces. One or both of /RREQ and /RRES can be omitted. /RREQ specifies which Unified ICM call variables the <in vars> parameters of the SEND REQUEST should be assigned to. /RRES specifies which Unified ICM call variables should be returned in the <out vars> parameters of the GET RESPONSE.

**Note:** As mentioned above, every GET RESPONSE must have the same number of <out vars>. For example,

```
/RREQ 7 2 10
```

This specifies that the first <in vars> variable in every SEND REQUEST command should be assigned to Unified ICM software call variable 7, the second to Unified ICM call variable 2, and the third to Unified ICM call variable 10. If a SEND REQUEST command specifies more than three <in vars> the other ones will be ignored. If it specifies less, the Unified ICM call variables corresponding to the unspecified NCCM server <in vars> will not be set.

```
/RRES 8 3
```

This specifies that Unified ICM call variable 8 will be returned in the first <out vars> variable, Unified ICM software call variable 3 will be returned in the second <out vars> variable and that **all** GET RESPONSE commands in your NCCM server scripts will have exactly two <out vars> variables.

**Note:** Whenever you change the Call Control Variable Map, you need to restart the Aura Contact Center PG for the new Call Control Variable Map to take effect.

### 4.3. Caller Entered Digits

Caller-entered digits (CED) obtained using the Aura Contact Center “Collect Digits Into” script command can be passed to the PG in a call variable.

### 4.4. Translation Routing

Translation routing is described in the *Scripting and Media Routing Guide for Cisco Unified ICM/Contact Center Enterprise & Hosted*. A quick review is presented here with emphasis on implementing translation routing with Aura Contact Center ACDs. Note that the Translation Route Wizard now automates much of the actual Unified ICM configuration work for translation routes.

#### 4.4.1. Review of How to Configure Translation Routes

A translation route is a mechanism for sending a call to a destination ACD X and passing information along with the call. The call information is passed from the CallRouter to the PG connected to X.

To send calls to an ACD X through a translation route, you perform the following steps:

- Configure a translation route T and associate T with the logical controller for the PG connected to X. Note that each translation route is associated with a single destination peripheral regardless of the routing client that submitted Unified ICM route request.
- Decide how many calls can be targeted to T and be “pending” at any given point in time. “Pending” means that the initial route request has been received from the initial routing client but the call has not yet arrived at the target and been matched up by OPC. Once the call arrives at X and is matched up by the PG associated with X it is no longer “pending.” A typical maximum number of expected pending calls would be 10. Allocate 10 unique DNIS values on X to be used only by T.
- For each DNIS value D assigned to T, create a route R<sub>d</sub> and set the target of R<sub>d</sub> to be T. Set the service of R<sub>d</sub> to be the “Translation Routing” service for the peripheral.

- For each  $R_d$  created above, create a single peripheral target  $PT_d$  with the DNIS set to  $D$ . The network trunk group can be set to any valid trunk group for the peripheral. Each  $PT_d$  should target its corresponding  $R_d$ . Note that the same peripheral targets are used for all routing clients.
- For each of the  $PT_d$  created above, create one label  $L_{dr}$  for each routing client  $R$  that will target calls to this translation route.

#### 4.4.2. Aura Contact Center Post-Routed Translation Routes

Every translation-routed call goes through a post-route at the destination peripheral (to get the label associated with the translation route DNIS). A post-routed translation route goes through two post routes: one at the source peripheral and one at the destination peripheral. If the source and destination peripherals are the same Aura Contact Center ACD, the Aura Contact Center PG handles the second post route directly without involving the ACD.

To make this happen, create one label associated with the Aura Contact Center PG routing client for each of the  $PT_d$  defined above of the form<sup>1</sup>:

^XXXX

Where XXXX is the DNIS stored in  $PT_d$ . When the PG receives such a label as a response to a post route request, it issues a second post route request using DNIS XXXX, gets back a new label, and returns the `response_type` and `response_value` specified by that label to the GET RESPONSE command that initiated the original post route request.

---

<sup>1</sup> Note that in the case being discussed, the translation route  $T$  is associated with the Symposium ACD that is both the source and destination of the translation route.



## **5. ACD-Specific Interpretation of Unified ICM Software Data**

This chapter discusses principles to keep in mind when attempting to compare Unified ICM database reporting elements to the reporting elements of the Aura Contact Center ACD.

## 5.1. Method of Attributing Calls to Services

The Aura Contact Center PG attributes a call to the service corresponding to the application associated with the **first** primary script to which the call interflows. It will not change the associated application if the call interflows to another primary script. This is the same as what the NCCM server does. See “Interflowed” in Chapter 2, “ACD Configuration,” for more information.

If a call is answered and then transferred to an Aura Contact Center CDN, the second call is tracked as an independent call to the destination service by the Aura Contact Center PG.

## 5.2. Method of Attributing Calls to Skill Groups

The Aura Contact Center PG attributes answered calls to Unified ICM skill group that corresponds to the NCCM server skill set in which the agent answered the call. Due to limitations in the Avaya Aura Contact Center interfaces, the PG usually will not know which skill group to attribute the call to until several seconds after the call is answered.

## 5.3. Calculation of Handle Time

The Unified ICM defines *handle time* for a call as “the time an agent spends talking on a call and performing related after-call work.”

The Aura Contact Center ACD allows an agent to go into “Not Ready” state to perform after-call work, but does not directly support the concept of attributing after-call work time to an individual call. Since an agent can activate the “Not Ready” key at any time, simply dividing the total “Not Ready” time for an agent by the number of calls answered will not yield an accurate average per-call after-call work time.

Within the limitations described in the following paragraphs, the Aura Contact Center PG attributes “Not Ready” time to individual calls if the agent enters the NCCM server “Not Ready” state directly after handling a call and before the NCCM server -assigned break time has elapsed. If the agent enters the “Not Ready” state in this interval the handle time for the call (and for the service) will include the time spent in the “Not Ready” state and the time spent in the “Break” state prior to entering the “Not Ready” state. Note that all time in the “Not Ready” state is also accounted for in the Unified ICM skill group wrap-up time statistics.

The preceding paragraph is an oversimplification. Due to limitations in the Avaya Aura Contact Center interfaces, the PG does not know how much break time (if any) Aura Contact Center has assigned to a given agent, nor does it know whether an agent has entered the “Break” state until several seconds after the call hangs up. Therefore, when a call hangs up, the PG assumes that the associated agent has entered the “Break” state, and waits for an RTD message that will tell it what the agent’s NCCM server state

really is. If the agent enters the “Not Ready” state in this interval<sup>1</sup>, the PG will assign all of the time since the call hung up to the handle time for the call, even if the agent had actually entered the NCCM server “Idle” state after the call hung up and had subsequently entered the “Not Ready” state. Also if the agent answers another call in the above mentioned interval, the PG will attribute all of the time before the new call is answered, to the handle time for the previous call even if the agent was actually in the “Idle” state between the two calls.

## 5.4. Handling of ROUTE CALL Script Command

Two cases can occur when the processing of a NCCM server call leads to the execution of a ROUTE CALL XXXX script command:

- **XXXX is a number that sends the call off-switch** (e.g., a number that includes a trunk access code).

In this case, the call is no longer under the control of the NCCM server software. When this occurs the PG receives no more information about the call and stops monitoring it. The call is removed from real time calls in queue statistics. The disposition in the termination call detail record is set to “Redirected.” The call is reflected in historical services records as an “overflow out” call.

If the call is routed to another CDN or ACD DN on the same switch (e.g., a trunk call that winds up going to a number on the same switch) the PG will track this as a new call.

- **XXXX is a number that is local to the switch** (e.g., the number of a local ACD DN).

In this case, the Aura Contact Center PG will continue to track the call as long as you have specified the “local” parameter in the HDX Routed command. (See “Routed” in Chapter 2, “ACD Configuration,” for more information.)

## 5.5. Handling of ROUTE CALL CONTROLLED Script Command

Two cases can occur when the processing of a NCCM server call leads to the execution of a ROUTE CALL XXXX CONTROLLED script command:

- **XXXX is a number that sends the call off-switch** (e. g. a number that includes a trunk access code).

In this case, the call **may** no longer be under the control of the NCCM server software. When the PG receives the SEND INFO command associated with the ROUTE CALL CONTROLLED it has no way of determining whether the ROUTE CALL CONTROLLED will terminate NCCM server processing, or whether control will return to the NCCM server script. Therefore, the PG waits for a period of time to see if it

---

<sup>1</sup> The interval between when the call hangs up and when the PG receives an RTD message telling it what SCCS state the agent entered after the call hung up.

will receive a Controlled\_Returned SEND INFO script command indicating that control has returned to the NCCM server script (see “Controlled\_Returned” in Chapter 2, “ACD Configuration,” for more information). If it does not receive such a command during the period, it assumes the call is no longer under the control of the NCCM server software and behaves as in “Handling of ROUTE CALL Script Command,” earlier in this chapter.

- **XXXX is a number that is local to the switch** (e.g., the number of a local ACD DN).

In this case, the Aura Contact Center PG will continue to track the call as long as you have specified the “local” parameter in the HDX Routed command. (See “Routed” in Chapter 2, “ACD Configuration” for more information.)

## 5.6. Handling of QUEUE TO NACD Script Command

When the processing of a call includes the execution of a QUEUE TO NACD XXXX script command<sup>1</sup>, several different things can subsequently happen to the call. The call could be:

- **Answered by the local NCCM server system**, either because it was also queued to skill sets and/or agents and one of those agents became available before any agent associated with XXXX, or because the day table associated with the XXXX contained a local ACD queue YYYY, and an agent became available on YYYY.

In this case, the Aura Contact Center PG will continue to track the call (see below).

- **Dequeued from the NACD queue**, in which case the call continues to be processed by the local NCCM server script.

In this case, the Aura Contact Center PG will continue to track the call (see below).

- **Answered by a remote system.**

In this case, the call is no longer under the control of the NCCM server software.

When this occurs the PG receives no more information about the call and stops monitoring it. The call is removed from real time calls in queue statistics. The disposition in the termination call detail record is set to “Redirected.” The call is reflected in historical services records as an “overflow out” call (see below).

If the call is routed to another CDN or ACD DN on the same switch the PG will track this as a new call.

The problem is that the Aura Contact Center PG has no way of knowing, *a priori*, which of the cases above will happen. Also, it will **never** know for

---

<sup>1</sup> As mentioned earlier, you should avoid using the QUEUE TO NACD script command

sure that the last case has occurred, because NCCM server does not send it any message when the call is answered by a remote site.

So, when the PG receives an HDX NACD\_Queued message telling it that a QUEUE TO NACD command has been executed for a call, it sets a timer T whose duration in seconds is specified by the registry entry (relative to HKEY\_LOCAL\_MACHINE/SOFTWARE):

```
Cisco Systems,
Inc./ICM/PG<xx>/PG/CurrentVersion/PIMS/pim1/SymposiumData/
Dynamic/QueueToNACDWaitTimeout
```

Each time it receives an HDX NACD\_Ping message, it reschedules T. If T goes off, the PG assumes that the call has been answered by a remote site and behaves as described in the third case above. Otherwise, the PG continues to track the call as described in the first two cases above. (See “NACD\_Ping” in Chapter 2, “ACD Configuration,” for more information.)

## 5.7. Handling of GIVE BUSY Script Command

When the processing of an NCCM server call leads to the execution of a GIVE BUSY script command, the call is no longer under the control of the NCCM server software. When this occurs the PG receives no more information about the call and stops monitoring it. The call is removed from real time calls in queue statistics. The disposition in the termination call detail record is set to “Forced Busy.” The call is reflected in historical services records as a “terminated other” call.

## 5.8. Handling of GIVE BUSY CONTROLLED Script Command

When the processing of a NCCM server call leads to the execution of a GIVE BUSY CONTROLLED script command, the call **may** no longer be under the control of the NCCM server software. When the PG receives the SEND INFO command associated with the GIVE BUSY CONTROLLED it has no way of determining whether the GIVE BUSY CONTROLLED will terminate NCCM server processing, or whether control will return to the NCCM server script. Therefore, the PG waits for a period of time to see if it will receive a Controlled\_Returned SEND INFO script command indicating that control has returned to the NCCM server script (see “Controlled\_Returned” in Chapter 2, “ACD Configuration”). If it does not receive such a command during the period, it assumes the call is no longer under the control of the NCCM server software and behaves as in “Handling of GIVE BUSY Script Command,” earlier in this chapter.

## 5.9. Handling of GIVE OVERFLOW Script Command

When the processing of an NCCM server call leads to the execution of a GIVE OVERFLOW script command, the call is no longer under the control of the NCCM server software. When this occurs the PG receives no more information about the call and stops monitoring it. The call is removed

from real time calls in queue statistics. The disposition in the termination call detail record is set to “Disconnect Drop No Answer.” The call is reflected in historical service records as a “terminated other” call.

### 5.10. Handling of GIVE OVERFLOW CONTROLLED Script Command

When the processing of a NCCM server call leads to the execution of a GIVE OVERFLOW CONTROLLED script command, the call **may** no longer be under the control of the NCCM server software. When the PG receives the SEND INFO command associated with the GIVE OVERFLOW CONTROLLED it has no way of determining whether the GIVE OVERFLOW CONTROLLED will terminate NCCM server processing, or whether control will return to the NCCM server script. Therefore, the PG waits for a period of time to see if it will receive a Controlled\_Returned SEND INFO script command indicating that control has returned to the NCCM server script (see “Controlled\_Returned” in Chapter 2, “ACD Configuration”). If it does not receive such a command during the period, it assumes the call is no longer under the control of the NCCM server software and behaves as in “Handling of QUEUE OVERFLOW Script Command,” earlier in this chapter.

### 5.11. Handling of DISCONNECT Script Command

When the processing of a NCCM server call leads to the execution of a DISCONNECT script command, the call is no longer under the control of the NCCM server software. When this occurs the PG receives no more information about the call and stops monitoring it. The call is removed from real time calls in queue statistics. The disposition in the termination call detail record is set to “Disconnect Drop No Answer.” The call is reflected in historical service records as a “terminated other” call.

### 5.12. Handling of Trunk Group Statistics

Due to limitations in the Avaya interfaces, the Aura Contact Center PG does not support Unified ICM Trunk Group real-time data elements and Trunk Group half-hour data elements.

### 5.13. Enhancements to the Dialed Number List Tool

The Dialer Number List Tool is enhanced to accommodate **one million** dialed numbers. This is achieved by using the *Customer Definition filter* and *Routing Client filters*. Additionally, the tool is redesigned to load the labels when a label change is made "only". These enhancements increase tool performance and reduce user interface time.

## 6. SEI Lite Interface with Avaya Aura Contact Center

This chapter gives an overview about how the Avaya Aura Contact Center administration interfaces with the NCCM server Avaya Aura Contact Center Event Interface (SEI Lite) interface using the Automated Administrator for Symposium (AAS) software. Please be informed that the AAS is an optional package with the Avaya Aura Contact Center PG<sup>1</sup>.

*See also:* For specific information on installation and troubleshooting information, see the *Cisco Unified ICM Automated Administrator for Symposium (AAS) Installation and Troubleshooting Guide*.

---

<sup>1</sup> Please be informed that there is no SEI version of the Symposium PG. The same version of the Symposium PG functions in both AAS and non-AAS environments.

## 6.1. Supporting Agent Re-skilling at the Unified ICM Software

The Aura Contact Center PIM can be modified to update the dynamic change in the agent or skill group mappings at the Unified ICM database. The change of agent skill group mapping or association can be done at the Agent Explorer/Skill Group Explorer. Alternatively, it can be made in the Aura Contact Center configuration when AAS is in use. For details about AAS, refer to Section 7.2. Once the agent skill group association is modified dynamically at the Unified ICM database through the Agent/Skill Group Explorers, the information will flow from Logger to Router to OPC to PIM, where PIM will update the agent state at OPC.

**Note:** The agent re-skilling feature is supported only on the Unified ICM. This feature provided by the SEI Lite Interface with NCCM server (formerly known as Symposium Call Center Server) is supported only in ICM releases 5.0(0) SR10, 6.0(0) SR3 and beyond.

## 6.2. Using the SEI Lite Feature with AAS

The Automated Administrator for Symposium (AAS)<sup>1</sup> is middleware software within the PG service that converts the NCCM server Avaya Aura Contact Center Event Interface (SEI) messages into Unified ICM software ConAPI messages.

The AAS component within the PG service is started and stopped along with the other PG components. AAS synchronizes the administrative changes made on the NCCM server with the Unified ICM database, thereby eliminating the need for a system administrator to administer changes twice. Without the AAS component, the system administrator has to administer changes once in the Avaya Administration, and once in the Unified ICM administration.

All additions, deletions and updates to agents and their skill sets made using Avaya Aura Contact Center administration are dynamically made to the Unified ICM database. The AAS synchronizes with the Aura Contact Center at startup to make sure that Unified ICM is up-to-date. No attempt is made to synchronize changes in the other direction. (That is, changes to agents' skill sets made on Unified ICM are not automatically reflected on the Avaya System).

---

<sup>1</sup> For Unified ICM support to AAS, the Administration and Data Servers must be installed to support the use of the ConAPI interface. The Administration and Data Servers can either be installed as a co-resident with the PG, or installed on a separate machine.

### 6.2.1. Minimum System Requirements

Following are the minimum system requirements for the SEI Lite interface to be integrated with the NCCM server via the AAS:

Product	Required Version
NCCM server	5.0 SU03 (with designer patch (NN_SCCS_5.0_DP_03_S) or SU6
Aura Contact Center Event Interface	No separate versioning required here
ICM	ICM Releases 5.0(0) SR10 and 6.0(0) SR3 (with any appropriate patches)

### 6.2.2. Known Limitations of the SEI Lite Feature

The AAS component in the SEI Lite feature has some limitations:

- AAS will **not** delete any agents or skill groups in Unified ICM. It only adds and removes agents to and from skill groups after creating them.
- When agents or skill groups are added in Aura Contact Center, they are added to the Unified ICM Configuration database, but are given default (non-descriptive) names.
 

**Note:** If the agent already exists, AAS does not over-write the name with a non-descriptive name.
- Standby agent mode is not supported.
- PG name in Unified ICM and skill name in Aura Contact Center must be kept short. Otherwise, AAS cannot generate a unique Enterprise name for the skill in Unified ICM. Total length of PG name and skill name combined cannot be more than 15 characters.
- Aura Contact Center Skillset name cannot be longer than 29 characters. Otherwise, AAS cannot generate a unique peripheral name for the skill in Unified ICM.



# Index

## A

AAS, 71  
 ACD  
   configuration, 25  
 ACD script modifications, 26  
 ACD scripts, 15  
 Active, 45  
 agent re-skilling, 71  
 Agent states, 45  
 Application, 16  
 Arrived command, 27  
 Associate Telephone (AST), 35  
 Aura Contact Center ACD capacity, 36  
 Aura Contact Center Event Interface, 70  
 Aura Contact Center Server (SCCS), 14  
 Aura Contact Center Server(SCCS), 14  
 Available, 45

## B

Break, 45  
 Busy, 45

## C

Call Control Variable Map, 59  
 Call Presented, 45  
 Caller-entered digits (CED), 60  
 Client Host Name field, 40  
 Client Instance field, 40  
 Client Login field, 40  
 Client Password field, 40  
 Client Provider ID field, 40  
 Consultation, 45  
 Controlled DN (CDN), 15  
 Controlled\_Returned command, 34

## D

Dequeued command, 30  
 Dequeued\_Agent command, 30  
 Disconnect command, 34

DO\_POST\_ROUTE, 54  
 Duplexed PG, 14

## E

Emergency, 45  
 Enqueued command, 29  
 Enqueued\_Agent command, 30  
 Enqueued\_MLA command, 29  
 Enqueued\_MLA\_Begin command, 29  
 Enqueued\_MLA\_End command, 29  
 Enqueued\_MLA\_Next command, 29

## G

GIVE RINGBACK command, 27  
 Give\_Busy command, 33  
 Gove\_Overflow command, 34

## H

Handle time, 64  
 Hardware and software requirements,  
   19  
 Hardware configuration, 14  
 HDX, 23  
 HDX Link Configuration, 40  
 Hold, 45  
 Host Data Exchange (HDX), 19  
 Host Data Exchange Interface (HDX), 13  
 Host Enhanced Routing, 19

## I

ICM configuration, 40  
   maintaining, 50  
 ICM configuration tools, 37  
 ICM features, 20  
 ICM Setup tool, 37  
 ICM software configuration, 40  
 Idle, 45  
 In-Bound Call Management, 19  
 Instance Number field, 39  
 Interflowed command, 28

**L**

Labels, 59  
Link Host Name field, 39  
Link Machine field, 39

**M**

Master script, 15, 54  
    post-routing example, 56  
Master Script example, 27  
Meridian Link Configuration, 39  
Meridian Link Interface (MLink), 13, 19  
Multiple application support, 20

**N**

NACD\_Dequeued command, 32  
NACD\_Ping command, 31  
NACD\_Queued, 30  
nbnmsrvc.exe, 23  
nicoms\_1.exe, 23  
Nortel Contact Center Manager Server,  
    14  
Nortel Contact Center Manager Server  
    Host field, 39  
Nortel Contact Center Manager Server  
    master script, 54  
Not Ready, 45, 64  
Not Ready Walkaway, 45

**O**

On Hold, 45  
On Hold Walkaway, 45  
Out-Bound Call Management, 19

**P**

Param String field, 47  
Peripheral Monitor table, 46  
Peripheral, 41  
Peripheral ID field, 39  
Peripheral Monitor table, 47  
Peripheral Name field, 38  
Peripheral service level reporting, 20  
Peripheral target, 41  
PG platform requirements, 23

Post-Routing, 53  
Primary script, 15

**Q**

QUEUE TO NACD command, 20, 28, 30

**R**

Real Time Data Interface (RTD), 13  
Real-Time Data (RTD), 19  
Reporting data, 64  
Reserved, 45  
Route Number, 35  
Routed command, 32  
Routing client, 46  
RTD, 23  
RTD Link Configuration, 40

**S**

Script  
    modifications, 26  
scripts  
    ACD, 15  
Secondary scripts, 15  
SEI Lite, 70  
Server Port field, 39  
Service members, 45  
Services, 43  
Simplex PG, 14  
Skill group mapping, 46  
Skill groups, 43  
Support for multiple applications, 20  
Swap Feature, 16

**T**

Talking, 45  
Translation Route Wizard, 60  
Translation routing, 60  
Translation Routing, 53  
Trunk Group data, 20  
Trunk groups, 42

**W**

Work Ready, 45