



Cisco CMR Premises

Solution Overview

First Published: January 2016

Release 6.0

Cisco TelePresence Conductor XC4.1

Cisco TelePresence Management Suite 15.1

Cisco TMS Provisioning Extension 1.6

Cisco TelePresence Server 4.2

Contents

Contents	2
Change History	4
Related Documentation	4
More Product Documentation on Cisco.com	5
Introduction	6
About the Solution	6
Key Benefits	6
Conference Types	6
Core Architecture for the Solution	7
Licensing	7
Primary and Secondary Deployments	8
Conference Bridges	8
Role of TelePresence Conductor	8
Role of Cisco TMS and Cisco TMSPE	8
BE6000 / BE7000 Platforms	9
Entry-Level Conferencing	9
Solution Products and Required Versions	10
Infrastructure Products	10
Endpoints and Soft Clients	11
Primary Deployment for the Solution	13
Extensions to the Primary Deployment	15
External Deployment	15
Interop Deployment	16
Legacy Deployment	18
Combined Deployment	19
Conferencing Services	20
Configuration Basics	20
Auto-Dialed Participants	20
Endpoints	20
Chained Conferences	20
Conferencing Features and Options	21
Active Meeting Manager (Preview Feature)	21
Conference Placement Method	22
ActiveControl to Endpoints	22
Multistream Video for Enhanced Layouts	22

Cascading	23
ClearPath and Packet Loss Resilience	24
Multiparty Licensing	24
Administration for TIP Multiscreen Devices	25
Optimizing Resources	25
Microsoft Lync 2013 Interoperability	25
Segment-Switched Display of TelePresence Rooms	25
Scheduling Conferences	27
Monitoring Conferences	27
Technology Concepts	29
Locations	29
Pools and Service Preferences	30
Encryption	30
Unified CM Normalization Script (Unified CM-Based Deployments Only)	31
Early Offer for SIP Messaging (Unified CM-Based Deployments Only)	31
Audio-Only Quality Setting in Ad Hoc Conferencing (Unified CM-Based Deployments Only)	31
IPv4	31
H.323 Interworking	31
Resilience and Clustering	31
Appendix 1: Secondary Deployment (VCS for Call Control)	32
Standard Secondary Deployment	33
External Secondary Deployment	34
Interop Secondary Deployment	35
H.323 Interop	35
Non-VCS Call Control Interop	35
Lync 2013 Interop	35
Requirements	36
Combined Secondary Deployment	37
Appendix 2: Conference Types	38
Accessibility Notice	39
Cisco Legal Information	40
Cisco Trademark	40

Change History

Table 1 Document Change History

Date	Changes	Reason
January 2016	First version.	New solution release.

Related Documentation

Title	Link
Cisco CMR Premises Release Notes 6.x	http://www.cisco.com/c/en/us/support/conferencing/telepresence-conductor/products-release-notes-list.html
Cisco TelePresence Conductor with Cisco Unified Communications Manager Deployment Guide Unified CM 11.x	http://www.cisco.com/c/en/us/support/conferencing/telepresence-conductor/products-installation-and-configuration-guides-list.html
Cisco TMS Provisioning Extension with Cisco Unified Communications Manager Deployment Guide	http://www.cisco.com/c/en/us/support/conferencing/telepresence-management-suite-extensions/products-installation-guides-list.html
Cisco TelePresence Conductor with Cisco VCS (B2BUA) Deployment Guide	http://www.cisco.com/c/en/us/support/conferencing/telepresence-conductor/products-installation-and-configuration-guides-list.html
Cisco TMS Provisioning Extension with Cisco VCS Deployment Guide	http://www.cisco.com/c/en/us/support/conferencing/telepresence-management-suite-extensions/products-installation-guides-list.html
Cisco TelePresence Conductor Administrator Guide XC4.1	http://www.cisco.com/c/en/us/support/conferencing/telepresence-conductor/products-maintenance-guides-list.html
Cisco Unified Communications Manager Administration Guide	http://www.cisco.com/c/en/us/support/unified-communications/unified-communications-manager-callmanager/products-maintenance-guides-list.html
Cisco Unified Communications Manager with Cisco Expressway (SIP Trunk) Deployment Guide	http://www.cisco.com/c/en/us/support/unified-communications/expressway-series/products-installation-and-configuration-guides-list.html
Cisco Unified Communications Manager with Cisco VCS (SIP Trunk) Deployment Guide	http://www.cisco.com/c/en/us/support/unified-communications/telepresence-video-communication-server-vcs/products-installation-and-configuration-guides-list.html
Cisco TelePresence Multiway™ Deployment Guide, Cisco VCS, MCU, Conductor	http://www.cisco.com/c/en/us/support/conferencing/telepresence-conductor/products-installation-and-configuration-guides-list.html
Cisco Expressway Basic Configuration Deployment Guide	http://www.cisco.com/c/en/us/support/unified-communications/expressway-series/products-installation-and-configuration-guides-list.html
Cisco VCS Basic Configuration (Control with Expressway) Deployment Guide	http://www.cisco.com/c/en/us/support/unified-communications/telepresence-video-communication-server-vcs/products-installation-and-configuration-guides-list.html
Cisco TelePresence Conductor with Cisco TMS Deployment Guide	http://www.cisco.com/c/en/us/support/conferencing/telepresence-conductor/products-installation-and-configuration-guides-list.html

Title	Link
Cisco TMS Administrator Guide Version 15.1	http://www.cisco.com/c/en/us/support/conferencing/telepresence-management-suite-tms/products-maintenance-guides-list.html
Cisco Collaboration Meeting Rooms (CMR) Hybrid Configuration Guide	http://www.cisco.com/c/en/us/support/conferencing/telepresence-management-suite-tms/products-installation-and-configuration-guides-list.html
Cisco TelePresence Conductor Product Programming Reference Guide XC4.1	http://www.cisco.com/c/en/us/support/conferencing/telepresence-conductor/products-programming-reference-guides-list.html
Cisco Expressway Administrator Guide X8.7	http://www.cisco.com/c/en/us/support/unified-communications/expressway-series/products-maintenance-guides-list.html
Cisco Expressway and Microsoft Lync Deployment Guide	http://www.cisco.com/c/en/us/support/unified-communications/expressway-series/products-installation-and-configuration-guides-list.html
Cisco VCS and Microsoft Lync Deployment Guide	http://www.cisco.com/c/en/us/support/unified-communications/telepresence-video-communication-server-vcs/products-installation-and-configuration-guides-list.html
Cisco TelePresence Video Communication Server Administrator Guide	http://www.cisco.com/c/en/us/support/unified-communications/telepresence-video-communication-server-vcs/products-maintenance-guides-list.html

More Product Documentation on Cisco.com

Product	Link
TelePresence Conductor	http://www.cisco.com/c/en/us/support/conferencing/telepresence-conductor/tsd-products-support-series-home.html
Cisco TMS	http://www.cisco.com/c/en/us/support/conferencing/telepresence-management-suite-tms/tsd-products-support-series-home.html
Cisco TMSPE and Cisco TMSXE	http://www.cisco.com/c/en/us/support/conferencing/telepresence-management-suite-extensions/tsd-products-support-series-home.html
TelePresence Server	http://www.cisco.com/c/en/us/support/conferencing/telepresence-server/tsd-products-support-series-home.html
MCU 5300 Series	http://www.cisco.com/c/en/us/support/conferencing/telepresence-mcu-5300-series/tsd-products-support-series-home.html
MCU MSE Series	http://www.cisco.com/c/en/us/support/conferencing/telepresence-mcu-mse-series/tsd-products-support-series-home.html
Cisco Expressway	http://www.cisco.com/c/en/us/support/unified-communications/expressway-series/tsd-products-support-series-home.html
Cisco VCS	http://www.cisco.com/c/en/us/support/unified-communications/telepresence-video-communication-server-vcs/tsd-products-support-series-home.html
Unified CM	http://www.cisco.com/c/en/us/support/unified-communications/unified-communications-manager-callmanager/tsd-products-support-series-home.html

Introduction

This guide describes the architecture for the Cisco Collaboration Meeting Rooms (CMR) Premises solution and the features it supports. For information about how to implement the solution see the relevant *CMR Premises Deployment Guide* (for Unified CM or for VCS) on the [CMR Premises solution documentation](#) web page.

The guide and the product-related documents that it references are written for partners and technical sales people. We assume a good technical understanding of Cisco video infrastructure products and their place in a video architecture. We also assume that you are familiar with installing and configuring the relevant products.

About the Solution

Cisco Collaboration Meeting Rooms (CMR) provide business-quality video collaboration services, which can be deployed on-premises or in the cloud. The CMR Premises solution is for on-premises implementations. CMR is also available as:

- CMR Hybrid, which supports participation by Cisco WebEx users in video conferencing.
- CMR Cloud, which supports video conferencing (and web conferencing) services from the Cisco cloud.

CMR Premises comprises a SIP-based video conferencing architecture with a set of supported deployments and endpoints. Together these components support various video conferencing methods.

The solution is available in two variants:

- Our primary deployment is for networks that use Cisco Unified Communications Manager (Unified CM) for call control. This deployment and its supported extensions are described in the main body of this guide.
- We also support a secondary deployment for networks that use Cisco VCS for call control. For details, see [Appendix 1: Secondary Deployment \(VCS for Call Control\)](#), page 32.

Key Benefits

- Optimal user experience for conference participants, delivered in a consistent manner regardless of user location, device, or meeting type.
- Flexible deployment, with virtualized, and dedicated hardware options.
- Efficient resource usage with dynamic optimization of conference resources on the TelePresence Server for inbound calls, and service-level capping.
- Ability to increase the number of conference participants beyond the capacity of a single conference bridge.
- High scalability, with options for mid-market organizations, and larger enterprise organizations.
- Resilience in the video network, which allows conference bridges to be taken offline for maintenance.

Conference Types

When three or more participants are involved in a call, the call becomes a conference. CMR Premises supports the following video conference types:

- Personal CMR
- Scheduled
- CMR Hybrid (joint participation by Cisco TelePresence and WebEx users)
- Ad hoc (or Multiway for systems with Cisco VCS for call control)
- Rendezvous

For details, see [Appendix 2: Conference Types](#), page 38

Core Architecture for the Solution

The solution uses these products in its core architecture.

- TelePresence Server conference bridges (Cisco TelePresence MCU Series bridges are also optionally supported).
- TelePresence Conductor to manage the conference bridge resources.
- Cisco TelePresence Management Suite (Cisco TMS) to schedule and monitor conferences.
- Cisco TelePresence Management Suite Provisioning Extension (Cisco TMSPE) to set up Personal CMRs.
- Unified CM (recommended) or Cisco VCS for the call control.

Figure 1 High-level view of the architecture

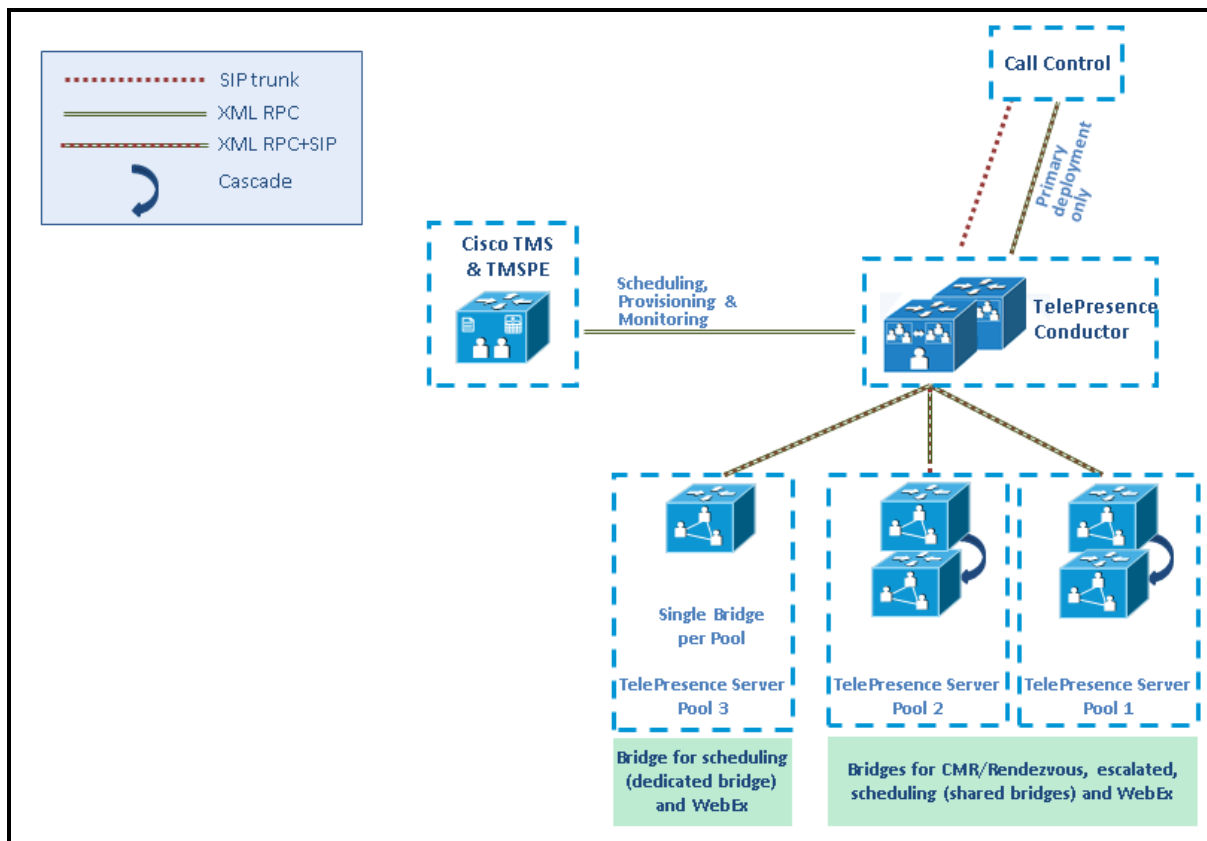

The conference bridges are SIP-trunked to the TelePresence Conductor, which manages the bridges centrally. Conductor is in turn trunked to one or more call controllers. All XML RPC connections route through the Conductor. Cisco TMS and TMSPE provide conference management services over XML RPC connections to Conductor.

The solution is IPv4 based, and is exclusively SIP. Conferencing with H.323 endpoints needs interworking by a Cisco VCS Control. TLS encryption is recommended for SIP signaling. SRTP encryption is recommended for media traffic.

The core architecture can be applied in various deployments, as described in this guide.

Licensing

As well as the conference bridges, Conductor also manages conference licensing centrally, using our Multiparty Licensing feature. Multiparty Licensing is the recommended licensing mode for the solution. We also support screen

licensing as an alternative (or port licensing with Cisco TelePresence MCU Series conference bridges).

Each Conductor can support either Multiparty Licensing or TelePresence Server screen licensing, but not both together. If you use a mix of TelePresence Server and MCU bridges, you can use Multiparty Licensing and port licensing on the same Conductor. That is, Multiparty Licensing for the TelePresence Servers and port licensing for the MCUs.

Primary and Secondary Deployments

The solution has two alternative deployments:

- **Primary Deployment.** For sites that use Cisco Unified Communications Manager for call control. Described in the main body of this guide. Also in *Cisco Collaboration Meeting Rooms (CMR) Premises Primary Deployment Guide* on the [CMR Premises solution documentation](#) web page.
- **Secondary Deployment.** For sites that use Cisco VCS for call control. Described in [Appendix 1: Secondary Deployment \(VCS for Call Control\)](#), page 32. Also in *Cisco Collaboration Meeting Rooms (CMR) Premises Secondary Deployment Guide* on the [CMR Premises solution documentation](#) listing page.

Each deployment has a set of supported extensions.

Conference Bridges

Conference bridges are grouped into pools of similar devices in TelePresence Conductor. Conductor applies Service Preferences to prioritize its use of the pools for specific conferences. The figure above shows co-located bridges in Pools 1-2 behind TelePresence Conductor.

Only Cisco multiparty conference bridges (such as the Cisco TelePresence Server and Cisco TelePresence MCU Series) are supported by Conductor. Other conference bridges are not supported.

Cisco TelePresence MCU Series Conference Bridges

We currently support Cisco TelePresence MCU Series conference bridges as an optional addition to the core architecture. The MCU supports Port Licensing whereas the TelePresence Server supports Multiparty Licensing.

Note: The MCU auto attendant is not used in the solution (it's not available on conference bridges managed behind Conductor).

Role of TelePresence Conductor

- Manages the video conferencing licenses centrally.
- Manages bridge resources. Selects which bridge or bridge pools to host a specific conference and balances the conference load across the bridges in the defined pools. The call controller is unaware of the individual bridges in the network and communicates only with TelePresence Conductor.
- Manages conference cascading across conference bridges.
- Dynamically optimizes the TelePresence Server conference bridges (*Optimize resources* must be enabled in the TelePresence Conductor conference template).

Role of Cisco TMS and Cisco TMSPE

- Provides conference scheduling facilities.
- Provides monitoring facilities for ongoing conferences, using the [Conference Control Center](#).
- Supports bulk provisioning of Personal CMRs by administrators, using Cisco TMSPE. Individuals can then activate and manage their own CMRs (and optionally set an access PIN) through the Cisco TMSPE user portal.
- As part of Personal CMR provisioning, notifies TelePresence Conductor how the video conferencing licenses are allocated.

BE6000 / BE7000 Platforms

The solution is supported for virtualized environments and is available for the Cisco Business Edition 6000 (BE6000) and Cisco Business Edition 7000 (BE7000) platforms.

Entry-Level Conferencing

We also support entry-level options using lower-cost platforms (which can be virtualized or physical) for lower capacity configurations.

Single-bridge configurations can use the Conductor Essentials trial version of Conductor, running as a virtual machine. Conductor Essentials does not need a release key.

Solution Products and Required Versions

To deploy the solution you need some or all of the products listed in this section, depending on which solution features you use. Each product you deploy must be running at a minimum the version specified here. The specified versions have been validated for this release of the solution.

Infrastructure Products

Table 2 Infrastructure product versions validated for this release

Product	Version	Role
TelePresence Conductor	XC4.1	Conference resource allocation
Cisco TMS	15.1	Conference management & scheduling
Cisco TMSPE	1.6	Conference provisioning
Cisco TMSXE	5.1	[Optional] Conference scheduling for Microsoft environments
TelePresence Server	4.2x (latest)	Conference bridge resource
MCU 5300 Series, MCU MSE 8510	4.5X (latest)	Conference bridge resource
Unified CM In networks with multiple Unified CM installations, for full solution functions each one must be at the version specified here.	11.0(1a)SU1 or later 10.5(2) also acceptable. Except not recommended for multistreaming / enhanced layouts.	Call control See the solution Release Notes , <i>Compatibility</i> section, for information about using earlier versions of Unified CM.
Cisco Expressway-C	X8.7 X8.5.3 or X8.6 also acceptable. Except Microsoft Lync screen sharing needs X8.6. Clustering with Lync screen sharing needs X8.7.	Remote endpoint registration to Unified CM, business-to-business connectivity, and Microsoft Lync interworking.
Cisco Expressway-E	X8.7 X8.5.3 or X8.6 also acceptable.	Secure firewall traversal
Cisco VCS Control In networks with multiple Cisco VCS installations, for full solution functions each one must be at the version specified here.	X8.7 X8.5.3 or X8.6 also acceptable. Except Microsoft Lync screen sharing needs X8.6. Clustering with Lync screen sharing needs X8.7.	Call control (Cisco VCS-Centric deployments). Microsoft Lync interworking. H.323 interworking.

Table 2 Infrastructure product versions validated for this release (continued)

Product	Version	Role
Cisco VCS Expressway	X8.7 X8.5.3 or X8.6 also acceptable.	Secure firewall traversal. Registration of standards-based endpoints across the Internet.
Microsoft Windows Server	Windows Server 2012 SP2 64-bit Windows Server 2008 R2 64-bit also acceptable. Except Active Meeting Manager feature needs Microsoft Server 2012 SP2 64-bit.	Database for Cisco TMS
Cisco WebEx	WBS (T) T30	Cloud conferencing with audio, video, and content sharing capabilities for WebEx clients

Microsoft Lync

You need Microsoft Lync Server 2013 and Lync 2013 for Windows clients. We do not support any other Lync servers or clients with the solution (including Skype for Business). For more details about Lync 2013 server and client requirements, see:

- *Cisco Expressway and Microsoft Lync Deployment Guide X8.7* on the [Expressway Configuration Guides](#) listing page for Unified CM-based deployments.
- *Cisco VCS and Microsoft Lync Deployment Guide X8.7* on the [VCS Configuration Guides](#) listing page for VCS-based deployments.

Endpoints and Soft Clients

Table 3 Endpoint and soft client versions validated for this release

Product	Version
Cisco TelePresence IX5000	IX 8.1
Cisco DX70, DX80	10.2.5
Cisco DX650	10.2.5
Cisco TelePresence MX200 G2, MX300 G2, MX700, MX800 (multistream-capable)	CE8.0 or TC7.3.4 CE8.0 needed for enhanced layouts (multistream video).
Cisco TelePresence MX200 G2, MX300 G2, MX700, MX800	TC7.3.4
Cisco TelePresence Quick Set SX20, SX80 (multistream-capable)	CE8.0 or TC7.3.4 CE8.0 needed for enhanced layouts (multistream video).

Table 3 Endpoint and soft client versions validated for this release (continued)

Product	Version
Cisco TelePresence Quick Set SX10, SX20	TC7.3.4
Cisco TelePresence Quick Set SX10 (not multistream-capable)	CE8.0 or TC7.3.4
Cisco TelePresence EX Series EX60 and EX90	TC7.3.4
Cisco TelePresence Quick Set C20	
Cisco TelePresence Codec C Series C40, C60, C90	
Cisco TelePresence Profile Series	
Cisco TelePresence MX200 and MX300	
Cisco TelePresence Systems CTS 3010, CTS 3210	CTS 1.10.11
Cisco TelePresence System CTS 1100, CTS 1300	CTS 1.10.11
Cisco TelePresence System CTS 500-32	TX6.1.9
Cisco TelePresence TX9000 and TX9200 immersive systems	TX6.1.9
Cisco Unified IP Phone 9900 Series and 8900 Series	9.4(2)
Cisco Jabber for Android	11.5
Cisco Jabber for iPad	
Cisco Jabber for iPhone	
Cisco Jabber for Mac	
Cisco Jabber for Windows	
Cisco Jabber Video for TelePresence	4.8.8

Primary Deployment for the Solution

Our primary deployment is for networks with Unified CM for call control. The deployment can be viewed as a single, large conference bridge behind the Conductor, combined with one or more Unified CMs for call control and a set of supported Unified CM-managed endpoints. Cisco TMS and Cisco TMSPE provide conference management services.

Figure 2 Standard primary deployment

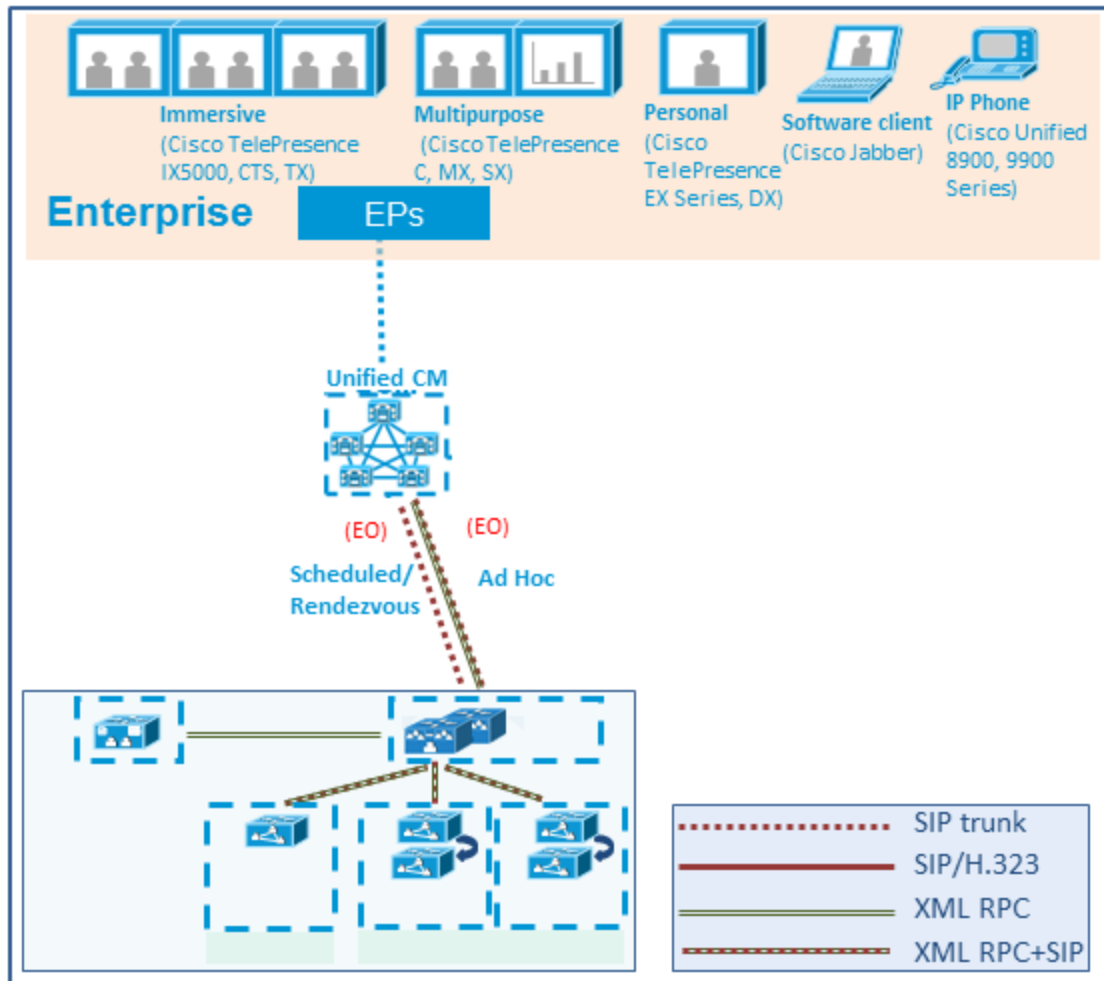

The standard primary deployment provides CMR Premises within the local enterprise. It can be extended to support the following cases:

- External. Participation by users outside the local enterprise.
- Interop. Interoperability with the Microsoft Lync service.
- Legacy. Interworking with standards-based endpoints.
- Combined. Any or all of these deployments in combination.

The Unified CM provides call registration services and routes voice and video between the connected endpoints.

Personal CMR / rendezvous, scheduled and ad hoc calls are carried over SIP trunks, as follows:

- Personal CMR / rendezvous and scheduled calls are routed along a single trunk from the Unified CM. The same trunk is used for outgoing calls.
Personal CMR / rendezvous and scheduled calls can route from any Unified CM. If a Cisco Unified Communications Manager Session Management Edition (Unified CM SME) is deployed it is assumed that it will be used for these trunks. Unified CM SME deployments need a trunk for each location.
- Ad hoc calls route directly to the TelePresence Conductor from the Unified CM which created the conference, so multiple ad hoc trunks may exist. Each one has an associated XML RPC connection. Ad hoc conferences are controlled by their originating Unified CM. This requires an API/SIP trunk pair from each Unified CM that supports conferencing.

Conferences for endpoints registered to Unified CM are channeled through TelePresence Conductor to the conference bridge.

Notes:

- Personal CMR / rendezvous and scheduled calls go to one or more IP addresses on TelePresence Conductor. These are separate from the IP addresses for ad hoc calls.
- Multiple Unified CMs can support the same Location. Where they do so, they can use the same Location destinations on TelePresence Conductor. For ad hoc and for Personal CMR / rendezvous and scheduled respectively.
- The Unified CMs do not need to be in the same physical location.

Extensions to the Primary Deployment

External Deployment

This deployment extends the standard architecture by trunking a Cisco Expressway to the Cisco Unified Communications Manager, to support conference access by external participants:

- Remote and mobile workers registered to the local Cisco Unified Communications Manager.
- WebEx based users.
- Users in other organizations (business-to-business conferencing).

Figure 3 Primary deployment with external access

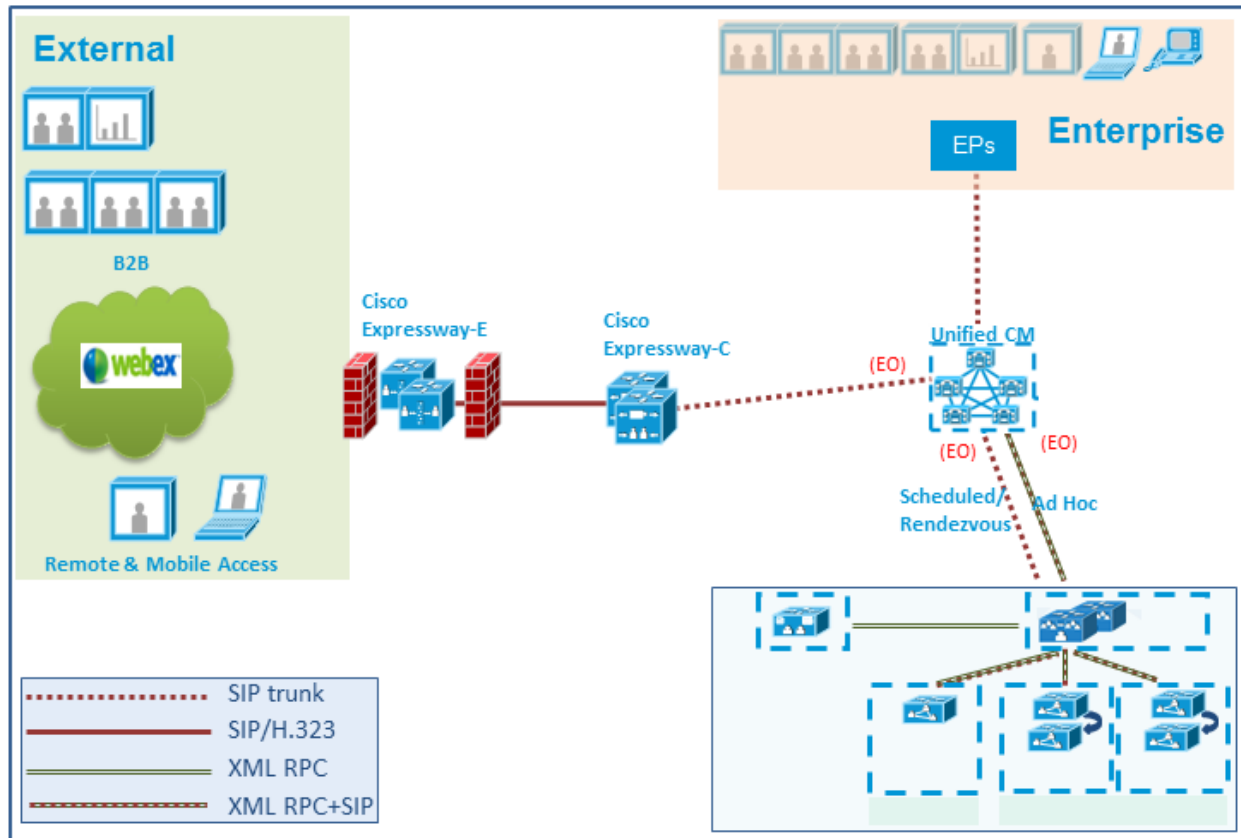

If you have not configured all SIP trunks for Early Offer as recommended, you *must* configure Early Offer between any bridges used for CMR Hybrid calls and the Cisco Expressway.

Interop Deployment

This deployment extends the standard architecture to support interoperability with the Microsoft Lync 2013 service over a Cisco Expressway-to-Unified CM trunk.

A Cisco Expressway-C acts as the Lync gateway, as follows:

- Interworks between Microsoft H.264 SVC (Scalable Video Coding) and standard H.264 SVC.
- Interworks between Microsoft H.264 SVC and standard H.264 AVC (Advanced Video Coding).
- From Expressway / VCS version X8.6, the solution supports screen sharing by Lync users within the local enterprise (not remote Lync users). Microsoft RDP originating from Lync clients is transcoded into H.264 for standards-based endpoints. Version X8.7 extends Lync screen sharing to clustered Expressway / VCS gateways. Clustering allows more screen sharing sessions to be simultaneously transcoded.

Reverse transcoding from the telepresence side (H.264) toward Lync (RDP) is not performed. Depending on the capability of the telepresence endpoint, Lync users see content either composed with the main video, or instead of the main video.

Limitations. Some restrictions currently apply to Lync screen sharing in the solution, as detailed in *Cisco Expressway with Microsoft Lync Deployment Guide X8.7* at [Expressway Configuration Guides](#) page (see the *Features and Limitations* section).

Lync users can participate in Personal CMR / rendezvous, scheduled, and ad hoc conferences.

Figure 4 Primary deployment with MS Lync 2013

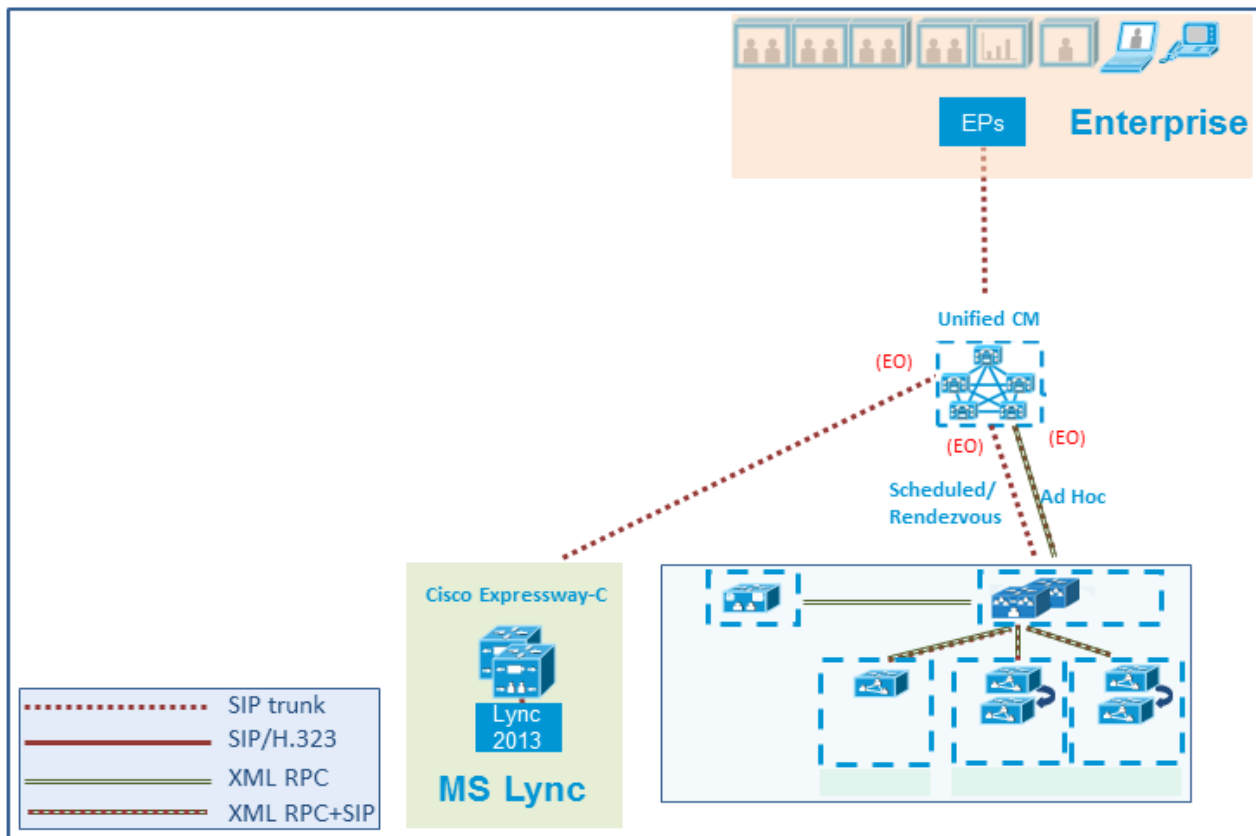

The following requirements apply to this deployment:

- You need Microsoft Lync Server 2013 and Lync 2013 for Windows clients. We do not support any other Lync servers or clients with the solution (including Skype for Business).
- For capacity reasons we recommend that you implement separate Cisco Expressway-C devices for Lync access, and for other networking requirements respectively. [Figure 6 Combined primary deployment, page 19](#) shows three devices: one for remote networking, one for Lync, and one for legacy interworking.
- You need the *Microsoft Interoperability* key (formerly known as *Enhanced OCS Collaboration*) for the Cisco Expressway-C.

More information is available in *Cisco Expressway and Microsoft Lync Deployment Guide* at [Expressway Configuration Guides](#) page.

Legacy Deployment

This deployment extends the standard architecture to support interworking with standards-based endpoints over a Cisco VCS-to-Unified CM trunk.

Figure 5 Primary deployment with standards-based endpoints

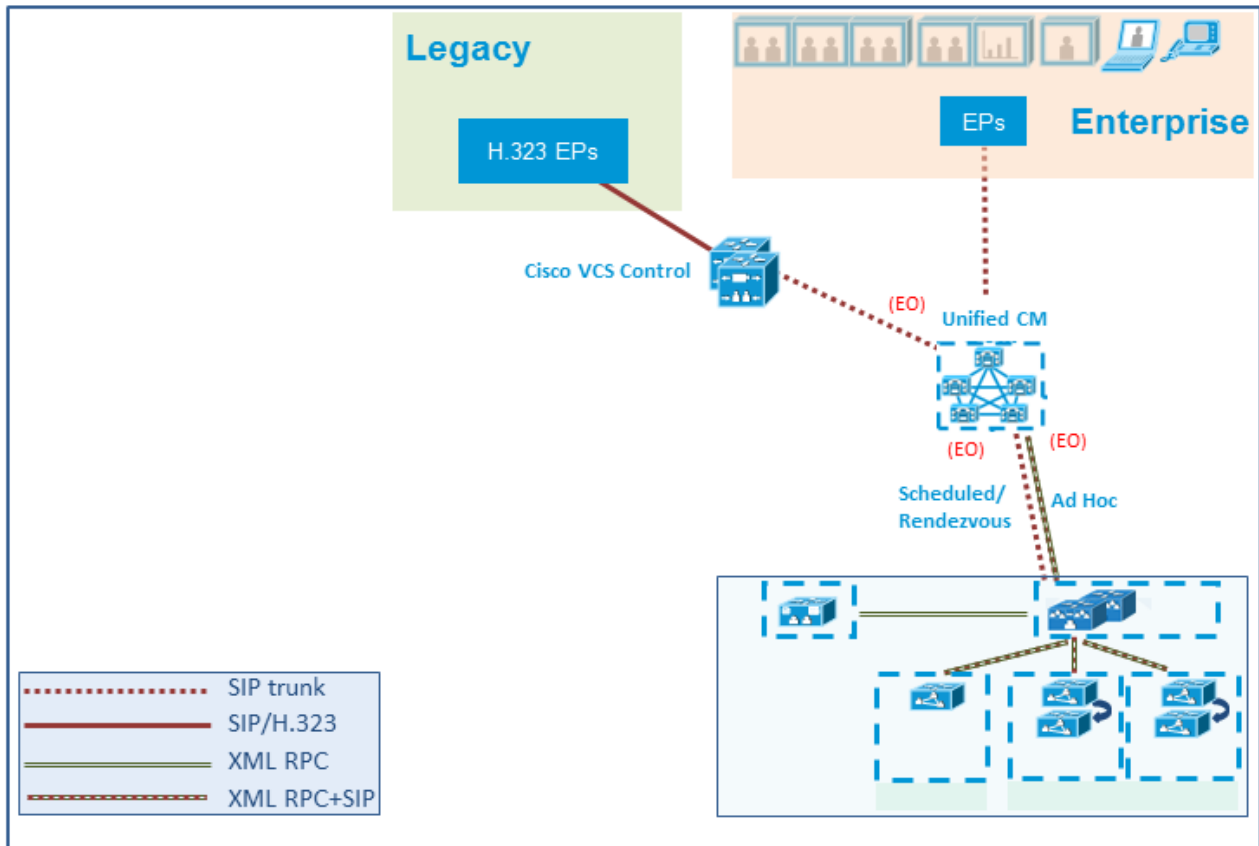

As in the standard primary deployment, Personal CMR / rendezvous conferences for endpoints registered to Unified CM are channeled through TelePresence Conductor to the conference bridge. Additionally for this deployment, endpoints registered to a Cisco VCS Control can be included in the following conferences:

- Personal CMR / rendezvous, scheduled, and CMR Hybrid conferences hosted on bridges behind the TelePresence Conductor connected to Unified CM.
- Ad hoc conferences can be initiated by an endpoint registered to Unified CM. Cisco VCS Control-registered endpoints cannot initiate ad hoc conferences, but can participate in them.

Combined Deployment

Any or all of the extended deployments can be used together. This diagram shows them all in a combined deployment:

Figure 6 Combined primary deployment

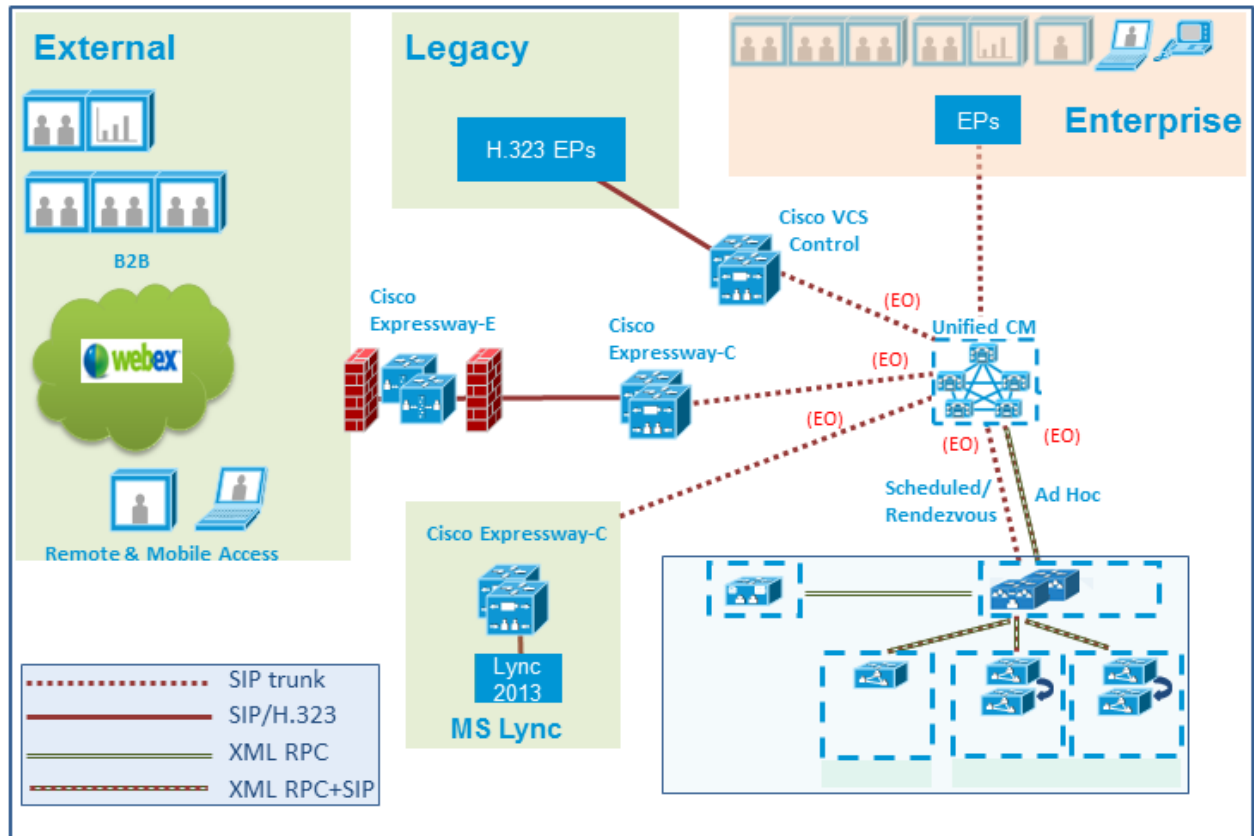

If you use Lync 2013 interworking in a combined deployment, for capacity reasons we recommend that you implement separate Cisco Expressway-C devices for Lync access. A further dedicated Cisco VCS Control is recommended if you need to support standards-based devices.

Conferencing Services

Configuration Basics

In the solution a Personal CMR / rendezvous conference is never statically defined on a single bridge. When the conference starts TelePresence Conductor load balances the conferences across the available bridges in a pool. Conference resilience is increased and you can still have unique conference settings per CMR.

CMR conferences need a SIP trunk between the call control device and TelePresence Conductor. The call control device routes CMR participants to the trunk's IP address.

Multiway conference requests are routed from Cisco VCS direct to the TelePresence Conductor, and hosted on a bridge connected to TelePresence Conductor. The endpoint user who escalates the call needs an endpoint that supports the Merge and Accept button. Multiway callers can be joined to a Personal CMR / rendezvous conference.

Conference bridges can be set up in the TelePresence Conductor to host ad hoc or Multiway escalated conferences only, Personal CMR / rendezvous conferences only, or both. Selecting both conference types can minimize the number of bridges needed. You only need equipment for the overall maximum number of conference participants, rather than the maximum ad hoc or Multiway participants and the maximum Personal CMR / rendezvous participants.

The solution does not support hosting mixed ad hoc escalations via Unified CM-registered endpoints and Multiway escalations via Cisco VCS-registered endpoints on the same set of conference bridges. We recommend migrating endpoint registration from Cisco VCS to Unified CM. For cases where endpoints must remain registered to Cisco VCS, separate, dedicated bridge resources should be implemented for ad hoc conferencing and for Multiway conferencing respectively.

Auto-Dialed Participants

The solution supports auto-dialing to participants for permanent conferences. Instead of dialing in to the conference themselves, participants can be auto-dialed. Auto-dialed participants are addresses that are automatically dialed when a conference starts. The address can relate to an endpoint or recording device or to any ID that can be dialed. Multiscreen endpoints do not support auto-dialed participants.

Endpoints

- Endpoints from other equipment providers can participate in conferences using standard SIP.
- For ad hoc conferences, endpoints must be registered to Unified CM.
- For Multiway conferences, endpoints must be registered to Cisco VCS.
- Unified CM-registered endpoints need a *Conference* button or softkey if they want to be hosts.
- Cisco VCS-registered endpoints need a *Merge/Accept* button or softkey if they want to be hosts.

Chained Conferences

Chained conferences should be avoided.

Usually all participants are part of the same conference. In contrast, a chained conference occurs if some participants are part of one conference, other participants are part of another conference, and the two conferences are linked or 'chained' together somehow.

For example, if a participant in an ad hoc conference is added into a Personal CMR / rendezvous or scheduled conference, or vice versa. The first conference is not extended to include the new participants. Instead a second conference is created and "chained" to the first. The result is a degraded conference experience. Each of the conferences appears as a single participant in the other conference, so multiple participants appear in a single video stream.

Conferencing Features and Options

Active Meeting Manager (Preview Feature)

The host of a CMR can easily make adjustments in an ongoing meeting using the Active Meeting Manager (AMM) in Cisco TMSPE. AMM uses a web browser interface and is a component of the CMR self-service portal.

Meetings that are currently scheduled by the Cisco TMSPE host are listed in the Cisco TMSPE Smart Scheduler.

The Cisco TMSPE administrator can control which AMM functions are available to meeting hosts. AMM displays the meeting participants list to hosts. From the list, hosts can:

- Mute or unmute a participant.
- Mute or unmute all participants.
- Remove a participant.
- Remove all participants.

Hosts can also generate and supply a WebEx link so that WebEx participants can join the meeting.

Limitations

- **WebEx**

- **Audio**

- If a WebEx connection is established for a meeting that uses TSP Audio, these two entries are displayed in the participants list:

- Cisco WebEx Meeting
 - Cisco WebEx Meeting (audio)

- If a WebEx connection is established for a meeting that uses IP Audio, only one entry is displayed in the participants list:

- Cisco WebEx Meeting

- **Muting and removing participants**

- If the host clicks the mute or unmute icon for the WebEx entry, the WebEx bridge is muted or unmuted, and therefore the audio from the bridge is muted/unmuted. All participants on the WebEx side of the conference will be muted/unmuted, accordingly.

- Muted WebEx participants can still send and receive audio and video from other WebEx participants, and receive audio from TelePresence endpoints.

- If the host clicks the remove icon for the WebEx entry, all participants who have joined the meeting through the WebEx bridge are disconnected from the TelePresence part of the conference.

- **Performance**

- Depending on your configuration and the number of concurrent meetings at any time, TMSPE and Smart Scheduler response times may be degraded if a significant number of meeting hosts use the AMM at the same time.

- **Endpoints**

- On multistreaming endpoints, participants do not see a video message on the endpoint if they are muted or removed from a meeting by the host.

- **Conferences**

- AMM only supports CMR conferences.

- **Browsers**

- Windows operating system**

- When using AMM with Windows, these browsers are recommended:

- Mozilla Firefox. Version 42
 - Internet Explorer. Version 11
 - Microsoft Edge. Version 20

- These browsers are *not* recommended for AMM with Windows:

- Chrome
 - Safari

- Mac operating system**

- Only the Mozilla Firefox version 42 browser is recommended when using AMM with the Mac OS.

Conference Placement Method

Conductor lets you specify the method it should use to select bridges for conferences:

- **Favor Scheduled.** Default setting. Selects the bridge with the fewest conferences currently in progress. Better for conferences that start at the same time.
- **Favor CMRs.** Selects the bridge with the most spare capacity. Better for conferences with staggered start times.

For details, see the relevant *CMR Premises Deployment Guide* (for Unified CM or for VCS) on the [CMR Premises solution documentation](#) web page

ActiveControl to Endpoints

ActiveControl allows participants in a video conference to view and change some aspects of the conference directly from the Touch controller on their endpoints. Users can see a list of participants and other conference information. On some models they can also change the local layout display and disconnect other participants.

ActiveControl is supported for endpoints with Touch controllers (version TC7.1.3 or later or CE 8.0 or later). It is not supported on other endpoints, including the Cisco TelePresence IX, TX or DX Series, Cisco TelePresence System CTS, or Cisco Jabber.

The ActiveControl feature on the TelePresence Server supports up to 500 participants.

Caution: ActiveControl needs to be configured with care, to avoid call problems when calling to external networks outside the local enterprise. For details, see the relevant *CMR Premises Deployment Guide* (for Unified CM or for VCS) on the [CMR Premises solution documentation](#) web page.

Multistream Video for Enhanced Layouts

The solution supports multistream video technology, which allows improved conference layouts on endpoints with multistreaming capability. The PiP placements are improved in the Equal and Prominent layouts when content is being shared. Dual-screen endpoints can display the conference participants across both screens. Conferences can have a mix of multistreamed and transcoded endpoints.

Requirements

- Cisco TelePresence Server on Virtual Machine, Cisco Multiparty Media 310/320, or Media 820 running TelePresence Server 4.2 software.

- Multistream-capable endpoints running software version CE8.0 (Cisco TelePresence MX200 G2, MX300 G2, MX700, MX800, SX20, SX80).
- The IX protocol must be enabled, and must be switched on in Unified CM and in Conductor. It's on by default in the TelePresence Server from Version 4.1.

Note By default multistreaming is on in the TelePresence Server and off in CE8.0 endpoints.

Limitations

Some restrictions currently apply to enhanced layouts. Detailed in the *Limitations* section of the *CMR Premises Release Notes* on the [CMR Premises solution documentation](#) web page.

- Enhanced layouts are only supported within the local enterprise. They are not supported for remote participants or for business-to-business conferences.
- Endpoints in multistream mode do not display conference status messages or administrator-configured messages on screen. So for example, users do not see conference end time warnings. Some message types are displayed on the Touch controller.
- Multistream systems may revert to transcoding mode if insufficient bandwidth exists to support video. This issue is more likely to occur with two-screen and three-screen systems, if insufficient bandwidth exists to support video to multiple screens.
- Upgrades to the next versions of the TelePresence Server software and the CE endpoints software should be done in parallel at the same time. If you upgrade the TelePresence Server software but not the endpoints, or conversely, conferences revert to transcoding mode until you upgrade the other component and they are back in step.

This requirement arises from our chosen approach to implement this feature. It is not a requirement of multistreaming itself.

- Enhanced layouts do not work through the Cisco Expressway / Cisco VCS back-to-back user agent (B2BUA). Note that the B2BUA is invoked if the **Media Encryption** mode setting for the Zone (trunk) is anything other than the default "Auto" setting.

Cascading

Within the local CMR Premises enterprise network, larger conferences that exceed the capacity of a single conference bridge can be cascaded. That is, distributed across one or more extra bridges. The bridges must be routable with each other and with TelePresence Conductor. The TelePresence Server (or MCU) API manages links between cascaded bridges.

The following conference types can be cascaded:

- Personal CMR / rendezvous.
- Scheduled, subject to the limitations described here.

Limitations and Requirements for Cascading

- Cascading is not supported from one conference bridge to another bridge that is outside the boundaries of the local enterprise network.
- Multistream video is not available over cascade links.
- Cascading is not supported from a TelePresence Server bridge to an MCU, or from an MCU to a TelePresence Server.
- On cascade-enabled conferences, cascading resources are reserved from the start of the conference based on the configured maximum number of cascades. The resources are reserved whether or not they are actually used.

For this reason, we recommend using the cascade option sparingly. Typically for large-scale meetings or for Personal CMR / rendezvous conferences used by VIP personnel.

- You should not enable cascading if it is critical to have certainty about resource availability. Such as a

- conference bridge that is reserved for scheduled conferences only.
- Cascade links share only a single screen of video between TelePresence Servers.

ClearPath and Packet Loss Resilience

Cisco ClearPath technology is supported for conferences, and uses advanced error correction techniques to optimize video quality over low quality connections. No configuration is required as ClearPath is enabled by default in all supported devices.

Multiparty Licensing

Multiparty Licensing lets you administer licenses centrally on the Cisco TelePresence Conductor instead of loading screen licenses locally onto the Cisco TelePresence Servers. Compared to traditional screen licensing, Multiparty Licensing allows for greater capacity at lower cost. Two variants are available:

- Personal Multiparty (PMP) licenses. Each license is assigned to a specific user. PMP licenses are suitable for users who initiate conferences frequently.
PMP licenses are purchased through Cisco Unified Workspace Licensing (CUWL Pro). They are available for deployments with Unified CM for call control.
- Shared Multiparty (SMP) licenses. Each license is shared by multiple users, but only in one conference at a time. SMP licenses are suitable for users who initiate conferences infrequently.
SMP licenses are available for deployments with either Unified CM or Cisco VCS for call control.

Each TelePresence Conductor can support either Multiparty Licensing or TelePresence Server screen licensing, but not both together. If you have a mix of TelePresence Server and Cisco TelePresence MCU Series conference bridges however, you can use Multiparty Licensing for the TelePresence Servers and port licensing for the MCUs together on the same Conductor.

Multiparty Licensing supports the following conference types:

- Personal CMR
- Ad hoc
- Scheduled
- [Cisco VCS-based deployments only] Multiway conferences can use SMP licenses, but not PMP licenses.

You assign PMP licenses to users when you configure Personal CMRs through Cisco TMSPE. If a user is not assigned a PMP then an SMP license is used for all video conferences initiated by the user (Personal CMR, scheduled, or ad hoc).

If license usage is exceeded, an alarm is raised that additional licenses need to be purchased.

Overlapping conferences consume two SMP licenses

Users who initiate back-to-back conferences will consume two SMP licenses if the first conference overlaps the second, either by running long or by the second conference starting five minutes early when the Allow Early Join feature is enabled on Cisco TMS.

Requirements for Multiparty Licensing

- Cisco TelePresence Server conference bridges, with software version 4.2 or later and running in remotely managed mode.
- TelePresence Conductor, with software version XC4.0 or later.
- Cisco TMSPE, with software version 1.5 or later. Cisco TMSPE is not required if you only use SMP licenses, although we recommend it to allow users to have a vanity URI/number.
- All connections between TelePresence Conductor and the TelePresence Servers must use HTTPS.

- [Unified CM-based deployments only] PMP licenses are associated with users for Personal CMR, scheduled, and ad hoc conferences, after the Personal CMRs have been configured in Cisco TMSPE.

Administration for TIP Multiscreen Devices

This feature applies to deployments with Cisco TIP multiscreen endpoints and TelePresence Server bridges. Cisco TIP devices are automatically allocated the appropriate number of screens up to the *Default maximum screens* setting in the template, except in the following cases:

- Pre-configured endpoints. Resources are allocated according to the configured settings.
- Ad hoc conferences. The default maximum screens defined in the conference template are allocated (although on subsequent successful connection, the allocation is optimized down if appropriate).

Manual configuration may still be needed for multiscreen devices that do not support TIP, and for some third-party devices. For details about resource allocation and optimization settings, see *Cisco TelePresence Conductor Administrator Guide*, on the [Conductor Maintain and Operate Guides](#) listing page.

Optimizing Resources

TelePresence Server resources are allocated to an individual endpoint based mainly on the number of screens it should use and the quality settings to apply for the endpoint. Resources are initially allocated when a participant joins the conference. Resource optimization refers to the ability subsequently to free up any unused portion of the initial allocation and make those resources available for other conferences or for later attendees. The **Optimize resources** setting for the conference template in Conductor controls resource optimization.

The TelePresence Server takes into account the receive bandwidth advertised by an endpoint, as well as the maximum resolution capabilities of the endpoint. Resource optimization does not occur for out-dialed participants. Out-dialed calling methods have their own mechanisms for defining specific quality requirements, which it would be inappropriate to override.

Note: For conferences on bridges that are dedicated for scheduling (one scheduling bridge per pool) Cisco TMS plans bridge usage ahead of actual usage, which means that the resources recovered by optimization are not actually re-used.

Microsoft Lync 2013 Interoperability

The solution supports interoperability with Microsoft Lync 2013 environments. Lync users can participate in Personal CMR / rendezvous and scheduled conferences, and in ad hoc or Multiway escalated conferences. For details, see [Interop Deployment, page 16](#) for Unified CM-based deployments, or [Interop Secondary Deployment, page 35](#) for VCS-based deployments.

Segment-Switched Display of TelePresence Rooms

The TelePresence Server supports two different switching modes for displaying speakers from telepresence rooms:

- Segment-switched (default)
- Room-switched

In the default segment switched mode (also known as speaker switching or panel switching) the TelePresence Server independently switches the display of individual cameras from a multiple camera system. Multiscreen endpoints show just the screen containing the loudest speaker of another multiscreen system instead of all screens. This can lead to a mixture of single-screen endpoints and individual screens of a multiscreen system being displayed at the same time. Segment switching only works for multiscreen systems that provide loudest pane information.

In room switched mode the TelePresence Server simultaneously switches all of the streams from the room into the display on another multiscreen endpoint. If a multiscreen endpoint is the loudest speaker, all of its screens are displayed full-screen on other multiscreen endpoints (if they have enough screens). If the multiscreen endpoint is not the loudest speaker, none of its screens are displayed full-screen on the other multiscreen endpoints.

An additional benefit of segment-switched mode is that single-screen endpoints are not forced into the Equal layout (NxN grid) when the group is in the conference. Instead they see the group in a row, and in the correct order. However, if the display of grouped endpoints on multi-screen systems is more important for your environment than segment switching or the single-screen experience, you can optionally change to room-switched mode.

For a detailed description of the two modes, including diagrams, see *Cisco TelePresence Server Release Notes* on the [TelePresence Server Release Notes](#) listing page.

Note: Conference participants with Cisco TelePresence IX5000, TX Series, or Cisco CTS endpoints can manually choose between segment-switched or room-switched mode.

Scheduling Conferences

Conferences are scheduled using Cisco TMS.

The configuration tasks to enable scheduling in CMR Premises are summarized in relevant *CMR Premises Deployment Guide* (for Unified CM or for VCS) on the [CMR Premises solution documentation](#) web page. The detailed configuration tasks are described in *Cisco TelePresence Conductor with Cisco TMS Deployment Guide* on the [TMS Configuration Guides](#) listing page.

Various configurations are possible to support scheduled conferencing in the solution. You can use a shared-bridge approach, which allows other conference types to run on the conference bridges, not just scheduled conferences. Or you can optionally reserve bridges for scheduling only. More information is in the relevant *CMR Premises Deployment Guide* (for Unified CM or for VCS) on the [CMR Premises solution documentation](#) web page.

Third-party endpoints from other equipment providers can also participate in scheduled conferences.

Caution: If you use clustered TelePresence Conductors, be aware that for failover purposes, Cisco TMS only recognizes one TelePresence Conductor node. If that cluster node should fail, the Cisco TMS scheduling service and its CMR provisioning service will be out of service (until the TelePresence Conductor is brought back up or Cisco TMS is updated to communicate with a different TelePresence Conductor in the cluster).

Participants in a scheduled conference should not escalate to an ad hoc or Multiway / instant conference. The effect is to create a new three-party conference, where one of the participants is the scheduled meeting. This results in a [chained conference](#) and a poor conference experience for the participants.

CMR Hybrid

If you have deployed CMR Hybrid, then Cisco WebEx and Cisco TelePresence users can participate jointly in scheduled meetings (or Personal CMRs). Both SIP and PSTN-based audio are supported for the audio portion of the call between WebEx and the conference bridges. The audio connections between WebEx participants and the WebEx conference can be PSTN audio, SIP audio, or computer telephony.

Personal CMRs

Users cannot schedule meetings to their Personal CMRs via the Cisco TMSPE user portal. However, when they schedule meetings through Microsoft Outlook they can include their Personal CMR for the meeting simply by adding the CMR alias to the “Location” field in the meeting invite.

Monitoring Conferences

The solution uses a subset of the Cisco TMS **Conference Control Center** features. Administrators can see which conferences are running on conference bridge resources, add or remove participants, hand over conference controls to a participant, and end a conference:

Table 4 Cisco TMS Conference Control Center features in the solution

On a conference	On a participant
Set the picture mode (only applied to participants who join after the setting is changed)	Mute/unmute audio
Add participant	Mute/unmute outgoing audio
End	Mute/unmute video
	Disconnect
	Change display name (the new name is not updated in the TMS interface)
	Send message

Table 4 Cisco TMS Conference Control Center features in the solution (continued)

On a conference	On a participant
	Show snapshot (MCU bridges only)
	Set picture mode

Conference Control Center features are not supported for cascaded conferences, except for visibility of which bridge a participant is connected to. Some Conference Control Center features are also unavailable on certain conference bridge models.

For information about using the Conference Control Center see *Cisco TelePresence Management Suite Administrator Guide* on the [TMS Maintain and Operate Guides](#) listing page, and the Cisco TMS help.

Technology Concepts

Information about how to configure the items described here is in *Cisco Collaboration Meeting Rooms (CMR) Premises Deployment Guide*.

Locations

In the context of CMR Premises, Locations are configured in the TelePresence Conductor. A standard TelePresence Conductor license supports up to 30 bridges and 30 locations.

Deployments with Unified CM for call control

In Unified CM-based solution deployments, Locations support Unified CM's need for separate trunks from Unified CM to TelePresence Conductor -- one for each Unified CM location (Unified CM expects to connect to separate conference bridges in different physical locations rather than to a single TelePresence Conductor).

Figure 7 Using Locations with Unified CM

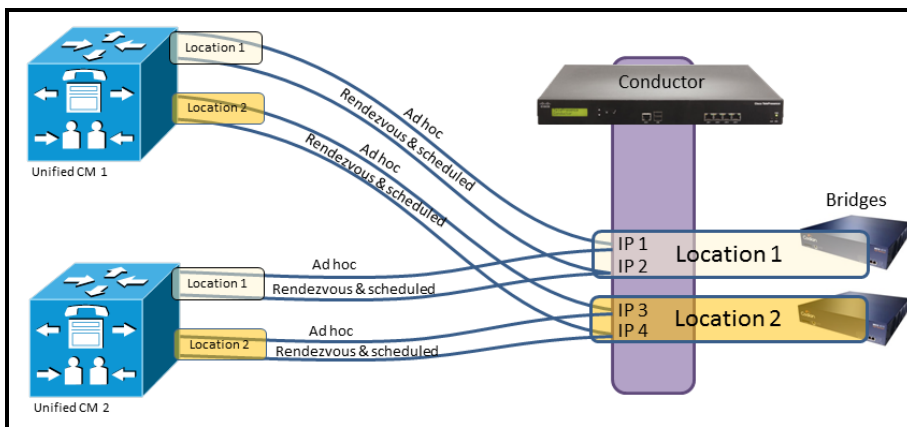

An ad hoc conference Location specifies an IP address on TelePresence Conductor to use for ad hoc calls in this Location. Plus the conference bridges and conference settings to use, as defined in the associated TelePresence Conductor conference template.

A Personal CMR / rendezvous conference Location specifies an IP address on TelePresence Conductor to use for Personal CMR / rendezvous calls in this Location. Plus the IP addresses and ports of the Unified CMs that are at the far end of the SIP trunks with TelePresence Conductor. These IP addresses and ports are used as the destination for outbound calls.

Notes:

- Personal CMR / rendezvous and scheduled calls go to one or more IP addresses on TelePresence Conductor. These are separate from the IP addresses for ad hoc calls.
- Multiple Unified CMs can support the same Location. Where they do so, they can use the same Location destinations on TelePresence Conductor. For ad hoc and for Personal CMR / rendezvous and scheduled respectively.
- The Unified CMs do not need to be in the same physical location.

Figure 7 Using Locations with Unified CM, page 29 shows multiple Unified CM clusters communicating with specific IP addresses on a TelePresence Conductor. UCM1 and UCM2 route ad hoc calls to Location 1 using the same IP address on TelePresence Conductor. UCM1 and UCM2 route ad hoc calls to Location 2 using another IP address. Personal CMR / rendezvous and scheduled calls are routed from both UCM1 and UCM2 to a single IP for Location 1 and to a single IP for Location 2.

Deployments with Cisco VCS for call control

In Cisco VCS-based solution deployments, a Location allows the Cisco VCS to forward conference call requests directly to the TelePresence Conductor back-to-back user agent (B2BUA). A single Location can handle all traffic between any Cisco VCS (or Cisco VCS cluster) and TelePresence Conductor.

Outbound Calls

Outbound calls from conference bridges to participants registered on or available via Unified CM are supported. Typically they are used to automatically dial participants into a conference, to add participants to an existing conference via the Cisco TMS Conference Control Center, or to add a recording server or audio bridge into a conference.

Outbound calls use the same SIP trunk as incoming Personal CMR / rendezvous or scheduled calls. To support outbound calls:

1. Specify one or more Trunk IP addresses and associated ports in the TelePresence Conductor Location. One of these Trunk IP addresses is used as the destination IP addresses for outbound calls.
2. Assign the Location to the bridge pool.

Pools and Service Preferences

Pools are configured in the TelePresence Conductor to organize and manage conference bridges. Each conference bridge in the deployment must be assigned to a conference bridge pool. To avoid unbalanced conference placement, the bridges in a pool should all be the same capacity. Usually it is best to configure a pool with bridges from the same location, although this is optional, not mandatory. Any conference bridge that is dedicated for scheduling use must be in a pool on its own.

Service Preferences are configured to define a prioritized order of preference in which TelePresence Conductor should attempt to use the conference bridge pools to host a conference. At least one Service Preference is required. A Service Preference can contain anywhere between 1 and 30 conference bridge pools. You can put all pools into a single Service Preference if you wish, and a pool can be used in any number of Service Preferences.

If you use Cisco TelePresence MCU Series bridges as well as TelePresence Servers, note that pools and Service Preferences should only contain the same bridge type (MCU or TelePresence Server).

For Personal CMR / rendezvous conferences, TelePresence Conductor uses the dialed number in order to select the conference bridges that it will use to host the conference. (Unified CM needs to select the trunk–Location trunk–based on the Personal CMR / rendezvous number or URI dialed.)

Figure 8 Pools and Service Preferences in CMR Premises

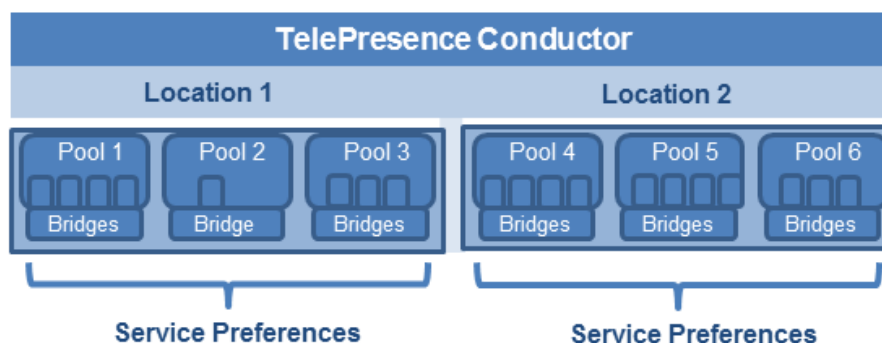

Encryption

- TLS is mandatory for TelePresence Conductor-to-bridge SIP communication, and Multiparty Licensing requires HTTPS connections between Conductor and the bridges.

- We recommend TLS encryption for other SIP (and XML RPC) communication between the endpoint and the call controller, and between the call controller and TelePresence Conductor.
- We recommend SRTP encryption for media traffic.

Unified CM Normalization Script (Unified CM-Based Deployments Only)

If you use encryption and TLS on SIP trunks used for TelePresence (recommended), you need to add one or more of the TelePresence normalization scripts to Cisco Unified Communications Manager.

Early Offer for SIP Messaging (Unified CM-Based Deployments Only)

With Early Offer messaging the session initiator sends its capabilities in the SIP Invite and the called device chooses the preferred codec. We strongly recommend that all SIP trunks which carry TelePresence calls are configured for Early Offer messaging. Early Offer is *required* for CMR Hybrid conferences and some third-party services.

Cisco VCS-Centric deployments always run in Early Offer mode, except for H.323 to SIP interworked calls. (Because H.323 uses Slow Start signaling mode on Cisco VCS and Cisco Expressway, SIP messaging for interworked calls is done using Delayed Offer.)

Audio-Only Quality Setting in Ad Hoc Conferencing (Unified CM-Based Deployments Only)

TelePresence Conductor supports audio-only as a quality setting (service level) for TelePresence Server conference bridges. Some limitations apply if you use the audio-only quality setting with ad hoc conferencing, and system behavior may not be as you expect.

IPv4

The solution supports IPv4 only. All Unified CM conference bridges and endpoints within the deployment must be configured to use IPv4.

H.323 Interworking

The CMR Premises network is SIP-based. If you want to connect H.323 endpoints to conferences in the CMR Premises network, the call must be interworked before reaching the TelePresence Conductor.

Resilience and Clustering

You can deploy the TelePresence Conductor as a cluster, except the TelePresence Conductor Essentials, which does not support clustering. Deploying clusters of TelePresence Conductors ensures service availability even if individual conference bridges or Conductors are taken out of service.

Clustering does not increase the maximum number of conference bridges / concurrent calls supported. So the full capacity Conductor can manage up to 30 conference bridges or 2400 concurrent conference calls, and this remains at 30 bridges / 2400 calls in a clustered deployment.

Caution: If you use clustered TelePresence Conductors, be aware that for failover purposes, Cisco TMS only recognizes one TelePresence Conductor node. If that cluster node should fail, the Cisco TMS scheduling service and its CMR provisioning service will be out of service (until the TelePresence Conductor is brought back up or Cisco TMS is updated to communicate with a different TelePresence Conductor in the cluster).

Appendix 1: Secondary Deployment (VCS for Call Control)

We provide a secondary deployment for organizations that use Cisco VCS for call control. The standard secondary deployment provides CMR Premises within the local Cisco VCS-managed enterprise. It can be extended to cover the following cases:

- External. Participation by users outside the local enterprise.
- Interop. Interoperability with non-VCS call control systems and Microsoft Lync 2013 services.
- Combined. Any or all of these deployments in combination.

Standard Secondary Deployment

Our secondary deployment can be viewed as a single, large conference bridge behind the TelePresence Conductor, combined with one or more Cisco VCSs for call control and a set of supported VCS-registered endpoints. Cisco TMS and Cisco TMSPE provide conference management services.

Figure 9 Standard secondary deployment

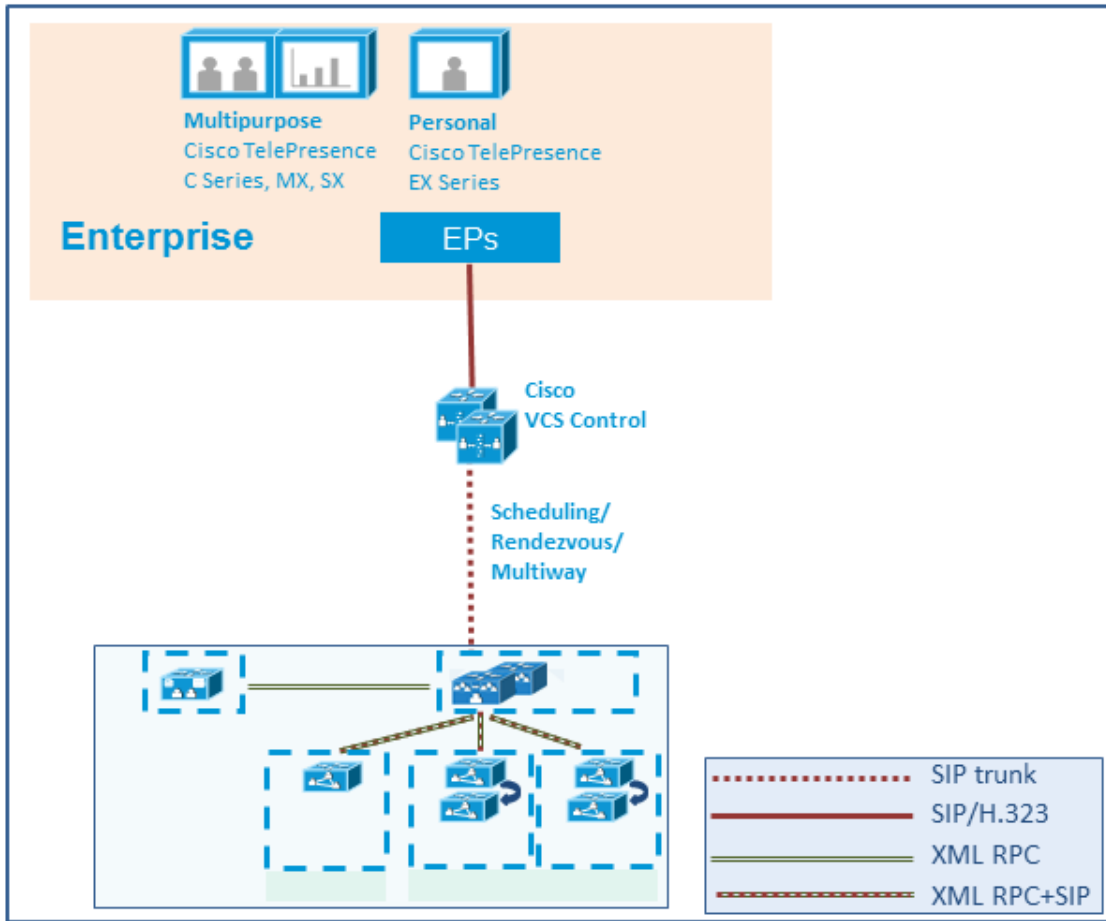

The Cisco VCS provides call registration and routing of voice and video between the connected standards-based endpoints. Personal CMR / rendezvous, Multiway and scheduled calls are carried over SIP trunks. All these call types are routed along a single trunk from the Cisco VCS. The same trunk is also used for outgoing calls.

Calls are managed by TelePresence Conductor on the conference bridges. Endpoints registered to the Cisco VCS Control can be included in Personal CMR / rendezvous, scheduled, and Multiway conferences hosted on the TelePresence Conductor-managed conference bridges. Multiway conferences can only be accessed if they are initiated by a Cisco VCS-registered endpoint.

External Secondary Deployment

This deployment trunks a Cisco VCS Expressway to the Cisco VCS Control to support conference access by external participants:

- Remote and mobile workers registered to the local Cisco VCS Expressway.
- WebEx based users.
- Users in other organizations (business-to-business conferencing).

Figure 10 Secondary deployment with external access

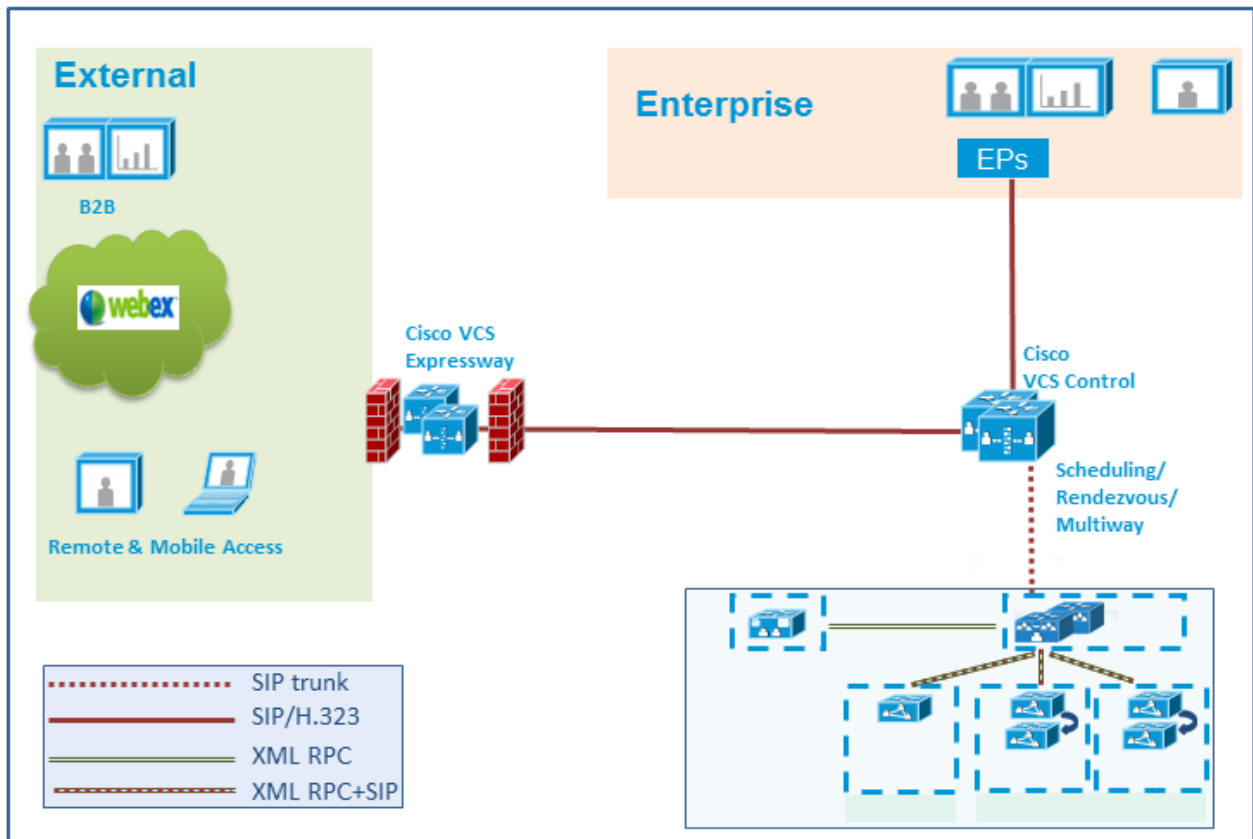

Interop Secondary Deployment

This deployment extends the standard secondary deployment to support interoperability with H.323 endpoints, non-VCS call control systems, and Microsoft Lync 2013 services within the enterprise.

Figure 11 Secondary deployment with interop support

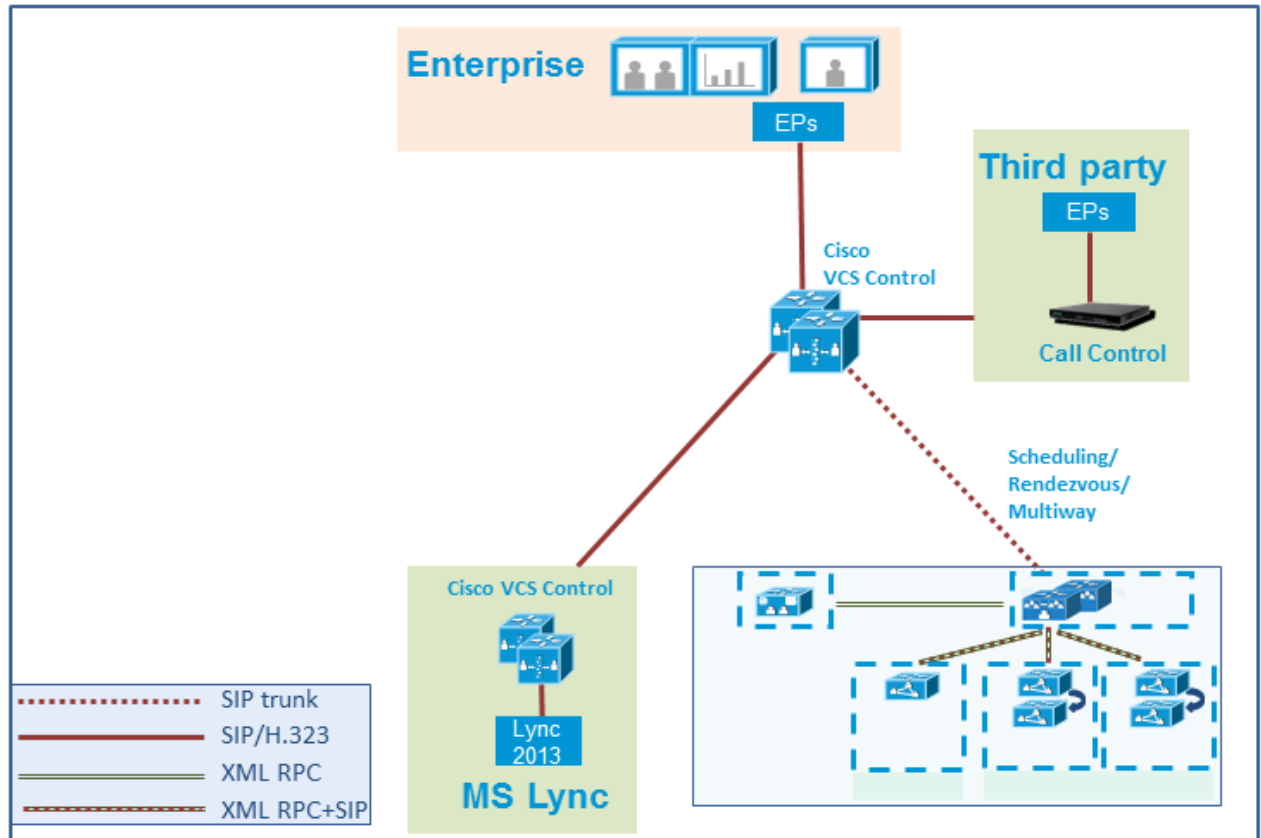

H.323 Interop

If you use H.323 endpoints in your deployment, they need H.323 / SIP interworking by a Cisco VCS Control component.

Non-VCS Call Control Interop

The diagram above shows a network configured to interoperate with a generic, third-party call control system for additional SIP-based voice and video endpoints. Calls managed by the third-party call controller are SIP-trunked to the Cisco VCS Control.

Lync 2013 Interop

A Cisco VCS Control acts as the Lync gateway, as follows:

- Interworks between Microsoft H.264 SVC (Scalable Video Coding) and standard H.264 SVC.
- Interworks between Microsoft H.264 SVC and standard H.264 AVC (Advanced Video Coding).

- From Expressway / VCS version X8.6, the solution supports screen sharing by Lync users within the local enterprise (not remote Lync users). Microsoft RDP originating from Lync clients is transcoded into H.264 for standards-based endpoints. Version X8.7 extends Lync screen sharing to clustered Expressway / VCS gateways. Clustering allows more screen sharing sessions to be simultaneously transcoded.

Reverse transcoding from the telepresence side (H.264) toward Lync (RDP) is not performed. Depending on the capability of the telepresence endpoint, Lync users see content either composed with the main video, or instead of the main video.

Limitations. Some restrictions currently apply to Lync screen sharing in the solution, as detailed in *Cisco TelePresence Microsoft Lync and Cisco VCS Deployment Guide X8.7* on the [VCS Configuration Guides](#) listing page (see the *Features and Limitations* section).

Lync users can participate in Multiway, Personal CMR / rendezvous and scheduled conferences.

Requirements

These points apply to the interop deployment:

- For Microsoft Lync interoperability, you need the following:
 - Microsoft Lync Server 2013 and Lync 2013 clients. We do not support any other Lync servers or clients with the solution (including Skype for Business).
 - The *Microsoft Interoperability* key (formerly *Enhanced OCS Collaboration*) for the Cisco VCS Control.
 - For capacity reasons we recommend that you implement separate Cisco VCS Control devices for Lync access and for general remote networking respectively (separate devices are illustrated in [Combined Secondary Deployment, page 37](#)).
- Conference participation by users of some external services, including Cisco WebEx, requires SIP messaging to be [Early Offer](#). This is the default for VCS-managed systems. But if you have a Unified CM in the network which supports WebEx or other Early Offer-based services, you must configure Early Offer messaging on the SIP trunks between the following elements:
 - Bridges used for calls between Early Offer-based services and the Cisco Expressway.
 - Any third-party call controller and the Cisco VCS Control.
 - Any Unified CM-managed endpoints and the Cisco Expressway. The entire path from the calling device to the service must be configured to support Early Offer.
- If you don't need external Early Offer-based services, then you can configure any Unified CMs in the network for either Delayed Offer or Early Offer.
- If you use Unified CMs in the network, we don't support the Unified CM-based ad hoc conference method in secondary deployments.

More information is available in *Cisco VCS and Microsoft Lync Deployment Guide* on the [VCS Configuration Guides](#) listing page.

Combined Secondary Deployment

Any or all of the extended secondary deployments can be used together. This diagram shows them all in a combined deployment:

Figure 12 Combined secondary deployment

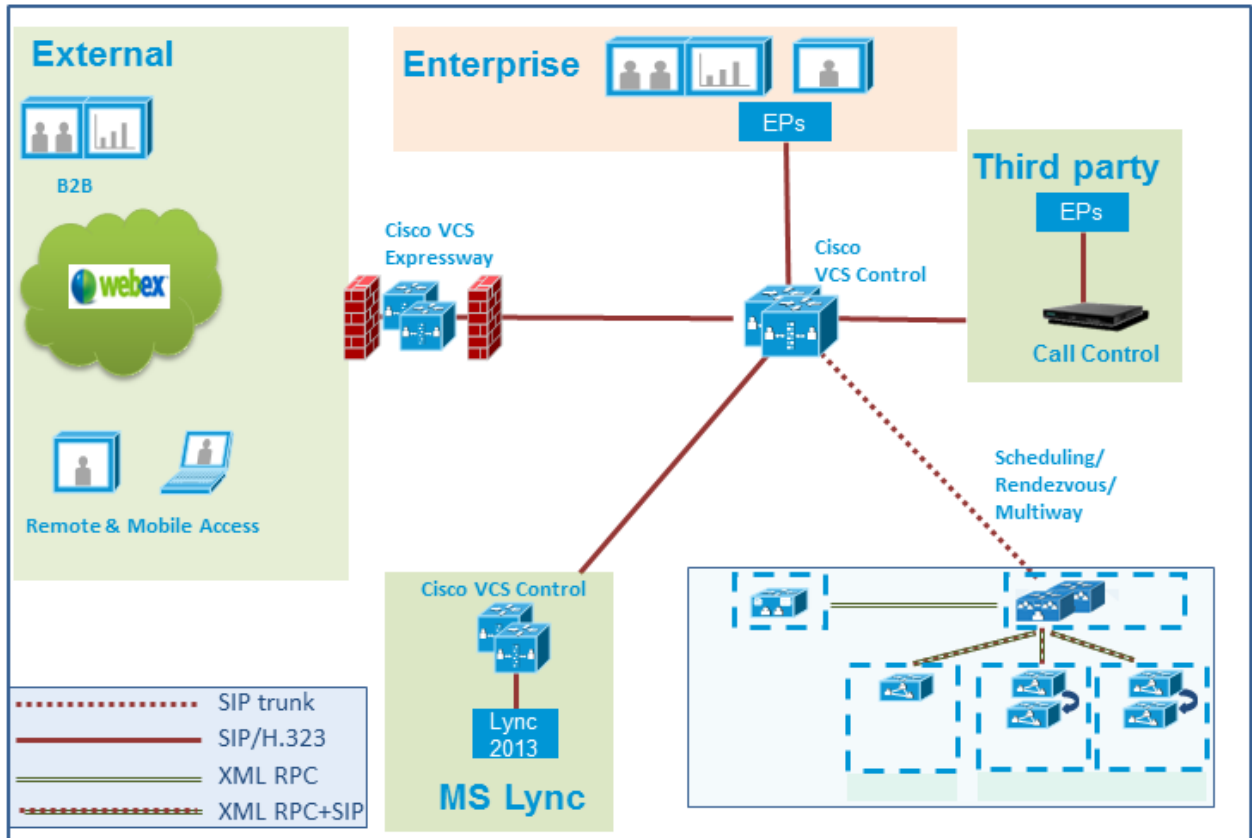

Use dedicated gateways with the Lync 2013 deployment

If you use Lync 2013 interworking in a combined deployment, for capacity reasons we recommend that you implement a separate Cisco VCS Control device for Lync access.

Appendix 2: Conference Types

Table 5 Video conference types supported in the solution

Type	Description	Notes
Personal CMRs Rendezvous	<p>Virtual meeting rooms provided by pre-defined aliases. Permanently available with no need to schedule in advance. Hosts invite other users to call into their virtual room.</p> <p>We support two permanent conferencing methods:</p> <ul style="list-style-type: none"> ■ Personal CMRs (recommended) ■ Rendezvous 	<p>Personal CMRs are managed through Cisco TMSPE.</p> <p>Rendezvous conferences are managed through TelePresence Conductor.</p>
Ad hoc	<p>The method used for instant (escalated) conferences in Unified CM-based deployments.</p> <p>An ad hoc conference happens when a user in a person-to-person call hosted on a Unified CM manually adds a third person into the call. The call becomes a multiparty call (an ad hoc conference) hosted on a conference bridge.</p> <p>More participants can be added to the ad hoc conference as necessary. When participants leave, the conference automatically returns to a point-to-point call when only two participants remain.</p>	<p>Also known as instant CMRs.</p> <p>Endpoints need a <i>Conference</i> button/softkey to add caller(s) and start an ad hoc conference.</p> <p>Remote access. Unified CM-managed endpoints which are located remotely from the CMR Premises enterprise network and registered through Cisco Expressway to the Unified CM can also escalate calls into an ad hoc conference.</p> <p>The solution does not support Multiway conferences in Unified CM networks.</p>
Scheduled	<p>Pre-booked conferences with a start and end time. Optionally with a pre-defined set of participants. Conferences are scheduled using Cisco TMS, typically by conference administrators.</p>	<p>Individuals can also schedule meetings to use their Personal CMRs, using standard Microsoft Outlook scheduling options (add the CMR alias to the Location field).</p>
CMR Hybrid	<p>Joint participation by Cisco TelePresence users and WebEx users in conferences is available by deploying the CMR Hybrid service.</p> <p>Combines on-premises video conferencing and WebEx cloud-based conferencing. Participants can join using the WebEx Meeting client or a TelePresence device, and experience two-way video, audio, and content sharing.</p> <p>Supported for scheduled meetings and for Personal CMRs.</p>	<p>Formerly known as WebEx Enabled TelePresence.</p>

Table 5 Video conference types supported in the solution (continued)

Type	Description	Notes
Multiway	<p>The method used for instant (escalated) conferences in VCS-based deployments.</p> <p>A Multiway conference happens when a user in a person-to-person call hosted on a Cisco VCS Control manually adds a third person into the call. The call becomes a multiparty call hosted on a conference bridge.</p> <p>More participants can be added to the Multiway conference as necessary. When participants leave, the conference automatically returns to a point-to-point call when only two participants remain.</p> <p>Users with CE8 endpoints can initiate ad hoc (instant) conferences on Unified CM, and participate in Multiway conferences initiated by others. A CE8 endpoint that initiates an ad hoc conference on Unified CM can invite VCS-registered endpoints.</p>	<p>Multiway conference requests are routed from Cisco VCS to the TelePresence Conductor and hosted on a Conductor-managed bridge.</p> <p>Endpoints need a <i>Merge and Accept</i> button to add callers and start a Multiway conference.</p> <p>Multiway callers can be joined to a Personal CMR / rendezvous conference.</p> <p>The solution does not support ad hoc conferences in Cisco VCS networks.</p>

Accessibility Notice

Cisco is committed to designing and delivering accessible products and technologies.

The Voluntary Product Accessibility Template (VPAT) for Cisco Collaboration Meeting Rooms (CMR) Premises is available here:

http://www.cisco.com/web/about/responsibility/accessibility/legal_regulatory/vpats.html#telepresence

You can find more information about accessibility here:

www.cisco.com/web/about/responsibility/accessibility/index.html

Cisco Legal Information

THE SPECIFICATIONS AND INFORMATION REGARDING THE PRODUCTS IN THIS MANUAL ARE SUBJECT TO CHANGE WITHOUT NOTICE. ALL STATEMENTS, INFORMATION, AND RECOMMENDATIONS IN THIS MANUAL ARE BELIEVED TO BE ACCURATE BUT ARE PRESENTED WITHOUT WARRANTY OF ANY KIND, EXPRESS OR IMPLIED. USERS MUST TAKE FULL RESPONSIBILITY FOR THEIR APPLICATION OF ANY PRODUCTS.

THE SOFTWARE LICENSE AND LIMITED WARRANTY FOR THE ACCOMPANYING PRODUCT ARE SET FORTH IN THE INFORMATION PACKET THAT SHIPPED WITH THE PRODUCT AND ARE INCORPORATED HEREIN BY THIS REFERENCE. IF YOU ARE UNABLE TO LOCATE THE SOFTWARE LICENSE OR LIMITED WARRANTY, CONTACT YOUR CISCO REPRESENTATIVE FOR A COPY.

The Cisco implementation of TCP header compression is an adaptation of a program developed by the University of California, Berkeley (UCB) as part of UCB's public domain version of the UNIX operating system. All rights reserved. Copyright © 1981, Regents of the University of California.

NOTWITHSTANDING ANY OTHER WARRANTY HEREIN, ALL DOCUMENT FILES AND SOFTWARE OF THESE SUPPLIERS ARE PROVIDED "AS IS" WITH ALL FAULTS. CISCO AND THE ABOVE-NAMED SUPPLIERS DISCLAIM ALL WARRANTIES, EXPRESSED OR IMPLIED, INCLUDING, WITHOUT LIMITATION, THOSE OF MERCHANTABILITY, FITNESS FOR A PARTICULAR PURPOSE AND NONINFRINGEMENT OR ARISING FROM A COURSE OF DEALING, USAGE, OR TRADE PRACTICE.

IN NO EVENT SHALL CISCO OR ITS SUPPLIERS BE LIABLE FOR ANY INDIRECT, SPECIAL, CONSEQUENTIAL, OR INCIDENTAL DAMAGES, INCLUDING, WITHOUT LIMITATION, LOST PROFITS OR LOSS OR DAMAGE TO DATA ARISING OUT OF THE USE OR INABILITY TO USE THIS MANUAL, EVEN IF CISCO OR ITS SUPPLIERS HAVE BEEN ADVISED OF THE POSSIBILITY OF SUCH DAMAGES.

Any Internet Protocol (IP) addresses and phone numbers used in this document are not intended to be actual addresses and phone numbers. Any examples, command display output, network topology diagrams, and other figures included in the document are shown for illustrative purposes only. Any use of actual IP addresses or phone numbers in illustrative content is unintentional and coincidental.

All printed copies and duplicate soft copies are considered un-Controlled copies and the original on-line version should be referred to for latest version.

Cisco has more than 200 offices worldwide. Addresses, phone numbers, and fax numbers are listed on the Cisco website at www.cisco.com/go/offices.

© 2016 Cisco Systems, Inc. All rights reserved.

Cisco Trademark

Cisco and the Cisco logo are trademarks or registered trademarks of Cisco and/or its affiliates in the U.S. and other countries. To view a list of Cisco trademarks, go to this URL: www.cisco.com/go/trademarks. Third-party trademarks mentioned are the property of their respective owners. The use of the word partner does not imply a partnership relationship between Cisco and any other company. (1110R)