

Cisco Bisync Tunneling Feature

PB508225

I.D. Number: 035PA Cisco Bisync Tunneling Feature

Last Updated: November 2008

Introduction

Cisco will add support for the Binary Synchronous (Bisync) protocol on the Cisco 2500, 4000, and 4500 serial interfaces. Bisync support will be added to Cisco's Internetwork Operating System™ (IOS) in the first half of 1995. Bisync support will allow customers to transport branch traffic from automated teller machines (ATMs) and other equipment that uses the Bisync protocol over the same links used for SNA and multiprotocol traffic. Integrated Bisync support will offer cost savings through consolidation of equipment and communication links in branch locations. Availability of Bisync applications is enhanced with Cisco's Bisync tunneling feature through the ability to reroute around failed links using IP rerouting.

Bisync Tunneling at a Glance

- Encapsulates Bisync traffic for transport over router links
- Supports installed Bisync devices and host applications without modification
- Uses standard synchronous serial interfaces on Cisco 2500s and the 4T network interface module (NIM) on the Cisco 4000 and 4500
- Supports point-to-point, multidrop, and Virtual Multidrop configurations

Bisync Tunneling Benefits Summary

- Consolidates Bisync traffic with other branch traffic
- Reduces equipment and line costs
- Enhances availability of Bisync applications
- Integrates network management

Binary Synchronous Protocol (Bisync)

Bisync is a byte-oriented, half-duplex, serial link protocol that predates SNA and SDLC. Although its use has declined since IBM introduced SNA in the early 1970s, Bisync is still used today in the banking, financial and retail markets. Bisync devices typically generate low traffic volumes and operate at line speeds of 9,600 bits per second, and in some cases, even lower. The maximum line speed support by Bisync is 19,200 bits per second. Low line speeds and traffic volumes make Bisync applications good candidates for consolidation over multiprotocol networks, however Bisync is not compatible with High-level Data Link Control (HDLC) and Synchronous Data Link Control (SDLC), the synchronous data-link protocols commonly supported by multiprotocol routers. Cisco will be the first major router vendor to support Bisync.

Cisco Bisync Tunneling Support

Cisco's IOS™ is being enhanced to support Bisync passthrough tunneling on Cisco routers. Cisco's Bisync support uses the same proven serial tunneling technology used in Cisco's SDLC tunneling and supports existing serial hardware on the Cisco 2500, 4000, and 4500 (4T NIM only).

Cisco's Bisync feature supports existing Bisync devices and Bisync host applications without modification to either. At the access router, traffic from the attached Bisync device is encapsulated in IP. The Bisync traffic can then be routed across arbitrary media to the host site where another Cisco router supporting Bisync will remove the IP encapsulation headers and present the Bisync traffic to the Bisync host or controller over a serial connection. HDLC can be used as an alternative encapsulation method for point-to-point links. Figure 1 below shows how Cisco routers can be used to support a Bisync connection.

Figure 1. Cisco routers consolidate Bisync traffic by encapsulating in IP or HDLC.

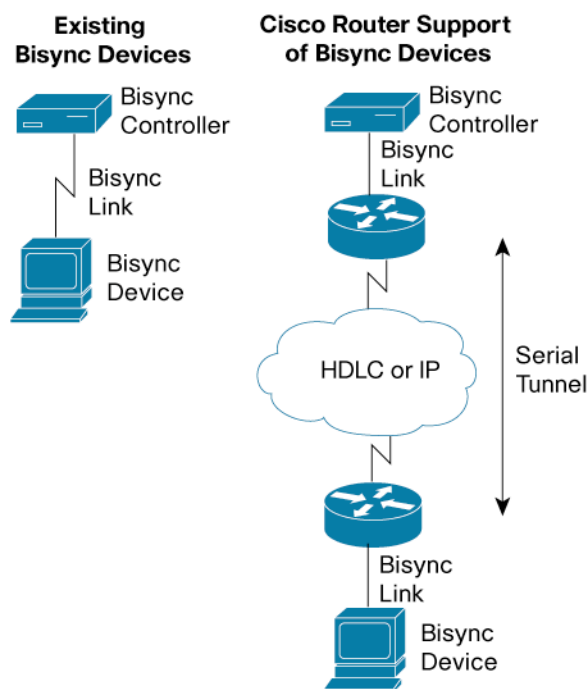

Cisco's Bisync feature supports point-to-point, multidrop, and Virtual Multidrop Bisync configurations. Multidrop configurations are common in Bisync networks where up to eight or ten Bisync devices are frequently connected to a Bisync controller port over a single low-speed link. Cisco's Virtual Multidrop support allows Bisync devices from different physical locations in the network to appear as a single multidrop line to the Bisync host or controller. Figure 2 below illustrates a multidrop Bisync configuration with and without Cisco routers.

Figure 2. Cisco's Virtual Multidrop support provides flexibility for integrating Bisync devices over a multiprotocol network.

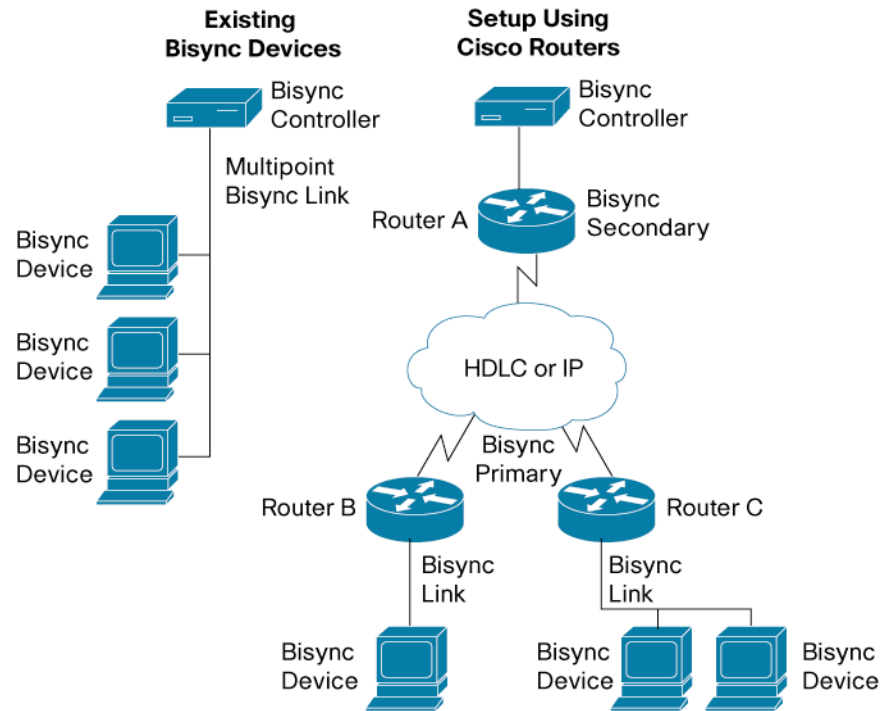

Bisync Integration

Support for Bisync tunneling on Cisco routers will allow enterprises to transport Bisync traffic over the same network that supports their SNA and multiprotocol traffic, eliminating the need for separate Bisync facilities. Banking and retail branches will be able to reduce networking costs, improve availability, and protect their investments in legacy Bisync equipment and applications by using Cisco's Bisync support.

A predominant use of Bisync today is in automated teller machine (ATM) networks. Much of the installed ATM equipment in North America was originally equipped with Bisync support. The cost to upgrade ATM devices to support SDLC is prohibitive in many cases. Maintaining separate communications facilities for Bisync ATMs is also expensive and is a deterrent to branch networking consolidation strategies. Using Cisco Bisync support to integrate ATM traffic with SDLC and LAN traffic in bank branches provides cost savings by eliminating dedicated Bisync transmission facilities and improves the availability of Bisync applications by rerouting around failed links. ATM integration using Cisco Bisync support is shown in Figure 3 below.

Figure 3. Automated Teller Machine (ATM) integration using Cisco Bisync support.

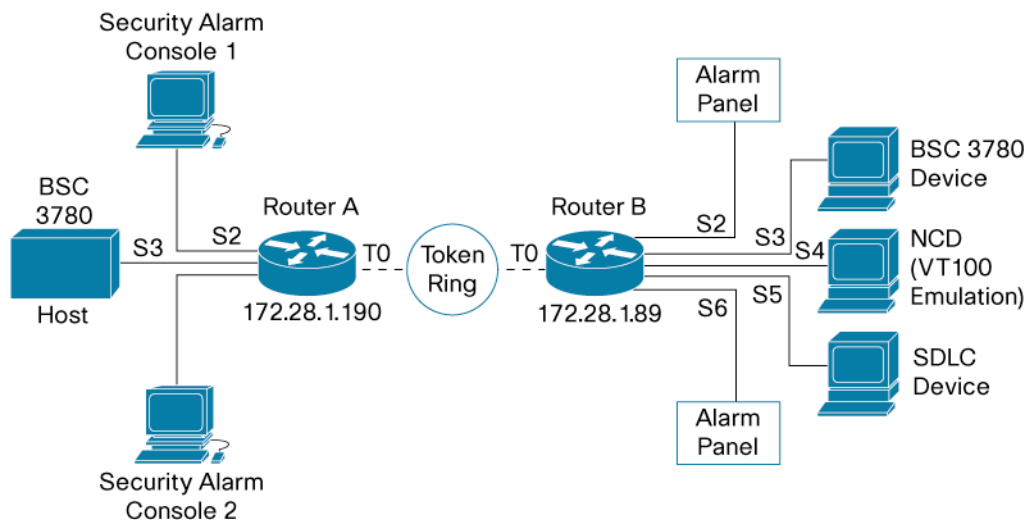

Bisync Interoperability

An age-old issue with Bisync is that, unlike SDLC and HDLC, Bisync is not based on a well-defined industry standard. As a result, Bisync implementations in products can vary in ways that effect compatibility and interoperability. Taking this issue into account, Cisco is implementing a passthrough tunneling method for Bisync support. Passthrough tunneling provides maximum flexibility to support a variety of Bisync implementations. The first products to be tested with Cisco Bisync support will be for ATMs that implement IBM 3270 Bisync and devices that emulate IBM 2780/3780 Bisync remote job entry (RJE) stations.

Limitations

Bisync tunneling will be supported only on the following Cisco hardware:

- Synchronous serial interfaces on the Cisco 2500 series
- The 4T serial network interface module (NIM) for the Cisco 4000 and 4500

Considering the low speed of Bisync, and the fact that most Bisync lines are multidropped, these platforms provide the most cost-effective interfaces for Bisync support—Cisco 2500s to connect Bisync devices in branches, and Cisco 4000 and 4500s to terminate multidrop Bisync lines in a host site.

Cisco Bisync supports products that implement IBM 3270 and 2780/3780 Bisync protocols. Other varieties of Bisync may not be compatible with Cisco's Bisync support feature.

The Cisco Bisync feature is a passthrough tunneling implementation, and as such, it does not support local acknowledgment or conversion to other media.

Cisco Bisync support is not a gateway and does not translate Bisync to SNA.

Planned Availability

Cisco Bisync support is currently in development. Field tests are planned for 4Q94. Controlled availability is planned for 1Q95, and general availability is planned for 2Q95.

Bisync support will be included in the IOS Enterprise feature set on the Cisco 2500 series and 4000 series routers.



Americas Headquarters
Cisco Systems, Inc.
San Jose, CA

Asia Pacific Headquarters
Cisco Systems (USA) Pte. Ltd.
Singapore

Europe Headquarters
Cisco Systems International BV
Amsterdam, The Netherlands

Cisco has more than 200 offices worldwide. Addresses, phone numbers, and fax numbers are listed on the Cisco Website at www.cisco.com/go/offices.

CCDE, CCENT, Cisco Eos, Cisco Lumin, Cisco Nexus, Cisco StadiumVision, Cisco TelePresence, Cisco WebEx, the Cisco logo, DCE, and Welcome to the Human Network are trademarks; Changing the Way We Work, Live, Play, and Learn and Cisco Store are service marks; and Access Registrar, Aironet, AsyncOS, Bringing the Meeting To You, Catalyst, CCDA, CCDP, CCIE, CCIP, CCNA, CCNP, CCSP, CCVP, Cisco, the Cisco Certified Internetwork Expert logo, Cisco IOS, Cisco Press, Cisco Systems, Cisco Systems Capital, the Cisco Systems logo, Cisco Unity, Collaboration Without Limitation, EtherFast, EtherSwitch, Event Center, Fast Step, Follow Me Browsing, FormShare, GigaDrive, HomeLink, Internet Quotient, IOS, iPhone, iQuick Study, IronPort, the IronPort logo, LightStream, Linksys, MediaTone, MeetingPlace, MeetingPlace Chime Sound, MGX, Networkers, Networking Academy, Network Registrar, PCNow, PIX, PowerPanels, ProConnect, ScriptShare, SenderBase, SMARTnet, Spectrum Expert, StackWise, The Fastest Way to Increase Your Internet Quotient, TransPath, WebEx, and the WebEx logo are registered trademarks of Cisco Systems, Inc. and/or its affiliates in the United States and certain other countries.

All other trademarks mentioned in this document or website are the property of their respective owners. The use of the word partner does not imply a partnership relationship between Cisco and any other company. (0809R)