

Gain 37 Percent More Network Throughput with Cisco Data Center VM-FEX and VMware vSphere Software



Performance Brief
August 2013

Highlights

Better Network Throughput

- Gain 37 percent greater network throughput using the Cisco® Data Center Virtual Machine Fabric Extender (VM-FEX) compared to the VMware Virtual Switch (vSwitch).

Better Transactional Performance

- Decrease round-trip times by 40 percent to accelerate performance of transactional applications.

Better Application Performance

- Using the same amount of bandwidth, data sent using the Cisco virtual interface card (VIC) with Cisco Data Center VM-FEX uses 41 percent fewer CPU resources than the VMware vSwitch, freeing CPU cycles to deliver better application performance.

Improve virtual machine network performance and free CPU cycles for better application performance with Cisco® virtual interface cards (VICs) and VMware vSphere software.

Traditional hypervisor environments handle network I/O by emulating virtual network interface cards (vNICs) and network switches. This approach consumes CPU cycles that could otherwise be used by applications while also slowing network throughput and performance. In conjunction with Cisco Data Center VM-FEX, Cisco VICs can directly connect virtual machines to physical network hardware that is dedicated to each virtual machine, eliminating the overhead of hypervisor intervention and switch emulation. Cisco's evaluation of a VMware vSphere environment with VMware vSwitch in comparison with a Cisco VIC with Cisco Data Center VM-FEX technology revealed that the Cisco solution provided 37 percent better network throughput and up to 40 percent shorter transaction round-trip times, with 41 percent less time consumed by the CPU core to transfer packets to the network. Better network throughput and shorter round-trip times can accelerate data-intensive and transactional applications, and the use of fewer CPU cycles to emulate network hardware makes more CPU cycles available to deliver application performance.

Cisco Data Center VM-FEX and VMware vSphere

Cisco VICs are converged network adapters (CNAs) that provide a set of dynamically configured NICs and host bus adapters (HBAs) to the PCI Express (PCIe) bus as independent physical devices without the need for any additional operating system software (Figure 1). The Cisco UCS® VIC 1240 used in Cisco's measurements can support up to 256 devices that can be accessed by operating systems, hypervisors, and virtual machines. Cisco Data Center VM-FEX makes this direct connection to the network possible. It is helped by VMware VMDirectPath technology, which allows per-virtual machine access to physical devices, and Intel® Virtualization Technology for Directed I/O (VT-d), which allows multiple virtual machine contexts to access the hardware with secure isolation from one another.

Cisco Data Center VM-FEX avoids the overhead of software-based networking to increase networking throughput and reduce system CPU utilization and provides a more responsive virtual infrastructure for I/O-intensive or CPU-bound applications. It also enables greater visibility of the virtual machine network and allows the network to be managed in the same way as the physical network.

Gain 37 Percent More Network Throughput with Cisco Data Center VM-FEX and VMware vSphere Software

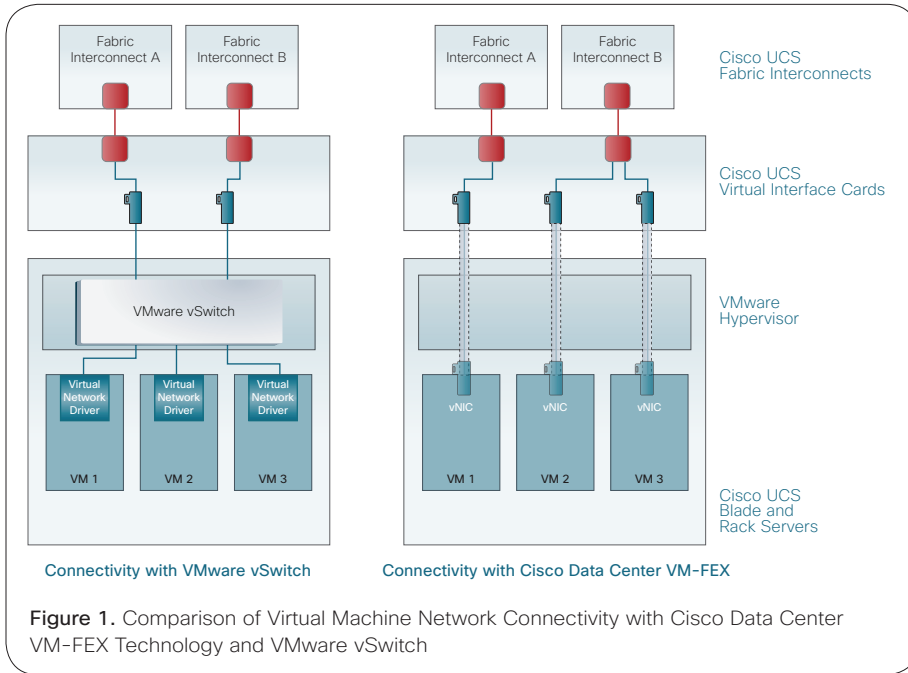

Figure 1. Comparison of Virtual Machine Network Connectivity with Cisco Data Center VM-FEX Technology and VMware vSwitch

Test Configuration

The goal of Cisco’s evaluation was to provide a simple, straightforward, and fair network performance comparison between virtual machines using a Cisco UCS VIC with Cisco Data Center VM-FEX and virtual machines using a VMware vSwitch. The test configuration included two Cisco UCS B200 M3 Blade Servers each equipped with a Cisco UCS VIC 1240. For the purpose of these benchmarks, a single virtual machine with a single virtual CPU (vCPU) and a single vNIC was attached to a single virtual machine running the test software.

Using the Cisco VIC with the VMware vSwitch, administrators can create multiple vNICs and associate them with one or more hypervisor switches

to distribute interrupt loads across multiple CPU cores. Conversely, Cisco Data Center VM-FEX enables direct

attachment of these independent vNICs to the virtual machine, bypassing the hypervisor network stack and the VMware vSwitch. This approach makes the Cisco VIC a uniquely flexible networking adapter that offers both scalability and performance without compromise.

The tests use the VMware esxtop tool to collect CPU utilization information. The netperf TCP_RR test was used to derive the bandwidth and round-trip-time metrics. For more information about the test configuration and results, please read Cisco Data Center Virtual Machine Fabric Extender (VM-FEX) Versus VMware vSwitch.

Performance Results

The benchmark results show that Cisco Data Center VM-FEX consumes less CPU while delivering higher bandwidth. When bidirectional bandwidth was tested, Cisco Data Center VM-FEX

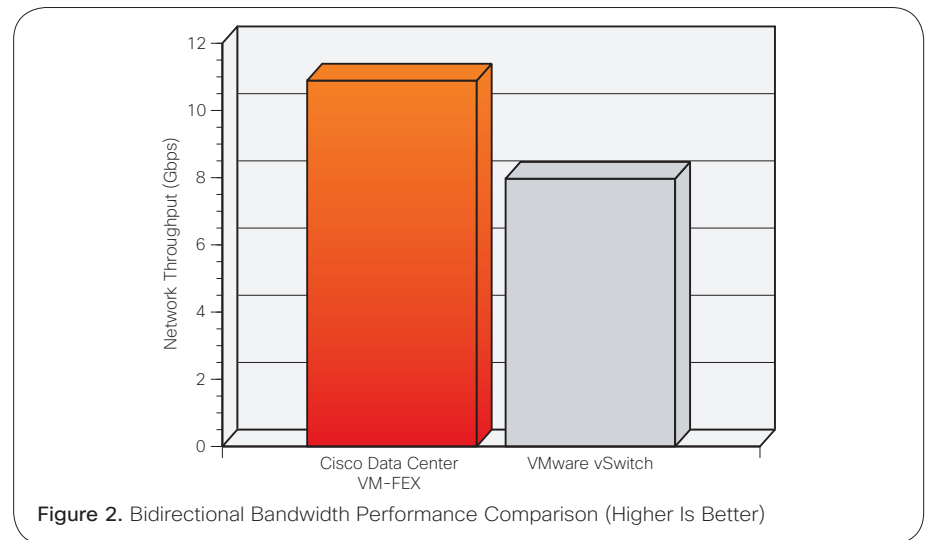

Figure 2. Bidirectional Bandwidth Performance Comparison (Higher Is Better)

Gain 37 Percent More Network Throughput with Cisco Data Center VM-FEX and VMware vSphere Software

delivered 36.6 percent greater network throughput than the VMware vSwitch for the same workload (Figure 2).

Cisco Data Center VM-FEX delivered 10.89 Gbps, and the VMware vSwitch delivered 7.97 Gbps of network throughput. When round-trip time was measured for small packet sizes (less than 512 bytes), Cisco Data Center VM-FEX delivered 46 percent faster times than the VMware vSwitch, with round-trip times as low as 16.11 microseconds.

Cisco Data Center VM-FEX used 65.60 percent of a single CPU core during this test, and the VMware vSwitch used 81.60 percent of the CPU (Figure 3). Using the same amount of bandwidth, Cisco Data Center VM-FEX uses 41 percent less of the CPU core than the VMware vSwitch to send and receive data.

Conclusion

Cisco Data Center VM-FEX with Cisco VICs offers significant performance benefits when compared to the VMware vSwitch. These performance benefits can lead to better application performance in scenarios in which network performance is important, such as streaming media applications and transactional environments in which fast round-trip time is critical. Cisco

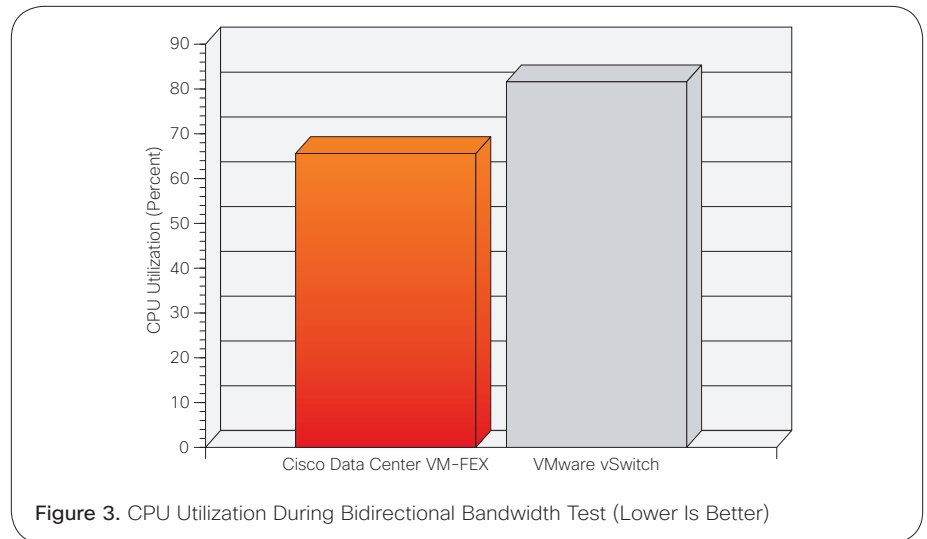

Figure 3. CPU Utilization During Bidirectional Bandwidth Test (Lower Is Better)

Data Center VM-FEX helps unburden the server CPU, giving business applications more processing power for greater performance and better response times.

For More Information

- For the complete story behind these performance results, please visit http://www.cisco.com/en/US/solutions/collateral/ns340/ns517/ns224/ns944/whitepaper_c11-727581.html.
- For more information about Cisco Data Center VM-FEX, please visit <http://www.cisco.com/en/US/netsol/ns1124/index.html>.

- For more information about the Cisco UCS VIC 1240 and I/O port expander card, please visit <http://www.cisco.com/en/US/products/ps12377/index.html>.
- For more information about the netperf performance tool, please visit: <http://www.netperf.org>
- For more information about the VMware esxstop tool, please visit: http://pubs.vmware.com/vsp40_i/wwhelp/wwhimpl/js/html/wwhelp.htm#context=resmgmt&file=c_performance_monitoring_utilities_resxstop_and_esxstop.html



Americas Headquarters
Cisco Systems, Inc.
San Jose, CA

Asia Pacific Headquarters
Cisco Systems (USA) Pte. Ltd.
Singapore

Europe Headquarters
Cisco Systems International BV Amsterdam,
The Netherlands

Cisco has more than 200 offices worldwide. Addresses, phone numbers, and fax numbers are listed on the Cisco Website at www.cisco.com/go/offices.