

# Cisco UCS C240 M8 EDSFF E3.S Rack Server

A printed version of this document is only a copy and not necessarily the latest version. Refer to the following link for the latest released version:

<https://www.cisco.com/c/en/us/products/servers-unified-computing/ucs-c-series-rack-servers/datasheet-listing.html>



---

# CONTENTS

<b>OVERVIEW</b>	<b>3</b>
<b>DETAILED VIEWS</b>	<b>4</b>
Chassis Front View	4
Chassis Rear View	5
<b>BASE SERVER STANDARD CAPABILITIES and FEATURES</b>	<b>7</b>
<b>CONFIGURING the SERVER</b>	<b>9</b>
STEP 1 SELECT SERVER SKU	10
STEP 2 SELECT MANAGEMENT MODE (REQUIRED)	11
STEP 3 SELECT RISER CARDS (REQUIRED)	12
STEP 4 SELECT CPU(s) (REQUIRED)	14
STEP 5 SELECT MEMORY (REQUIRED)	17
Memory configurations and mixing rules	20
STEP 6 SELECT DRIVE CONTROLLERS	21
STEP 7 SELECT DRIVE CABLING OPTIONS (REQUIRED)	22
STEP 8 SELECT DRIVES (OPTIONAL)	23
STEP 9 SELECT OPTION CARD(s) (OPTIONAL)	24
ORDER OPTIONAL PCIe OPTION CARD ACCESSORIES	27
STEP 10 ORDER GPU CARDS (OPTIONAL)	29
STEP 11 ORDER M.2 BOOT RAID CONTROLLER and SATA SSDs (OPTIONAL)	31
STEP 12 ORDER POWER SUPPLY (REQUIRED)	33
STEP 13 SELECT INPUT POWER CORD(s) (REQUIRED)	34
STEP 14 ORDER TOOL-LESS RAIL KIT (REQUIRED) AND REVERSIBLE CABLE MANAGEMENT ARM (OPTIONAL)	38
STEP 15 SELECT MANAGEMENT CONFIGURATION (OPTIONAL)	39
STEP 16 ORDER SECURITY DEVICES (REQUIRED)	40
STEP 17 SELECT LOCKING SECURITY BEZEL (OPTIONAL)	41
STEP 18 SELECT OPERATING SYSTEM	42
STEP 19 CISCO INTERSIGHT	45
<b>SUPPLEMENTAL MATERIAL</b>	<b>47</b>
Serial Port Details	49
KVM Cable	49
<b>SPARE PARTS</b>	<b>50</b>
<b>TECHNICAL SPECIFICATIONS</b>	<b>52</b>
Dimensions and Weight	52
Power Specifications	53
Extended Operating Temperature Hardware Configuration Limits	57
Compliance Requirements	58
<b>DISCONTINUED EOL PRODUCTS</b>	<b>59</b>

---

# CONTENTS

## OVERVIEW

The Cisco UCS C240 M8 EDSFF E3.S Rack Server extends the capabilities of Cisco's Unified Computing System portfolio in a 2U form factor with the Intel® Xeon® 6 Scalable Processors, 16 DIMM slots per CPU for DDR5-6400 Memory DIMMs with DIMM capacity points up to 256GB.

The Cisco UCS C240 M8 EDSFF E3.S Rack Server harnesses the power of the latest Intel® Xeon® 6 Scalable Processors and offers the following:

**CPU:** Up to 2x Intel® Xeon® 6 Scalable Processors with up to 86 cores per processor.

**Memory:** Up to 8TB with 32 x 256GB DDR5-6400 DIMMs, in a 2-socket configuration with Intel® Xeon® 6 Scalable Processors.

**mLOM:** The UCS C240 M8 EDSFF E3.S Rack Server has a single integrated 1GbE management port. A modular LAN on motherboard (mLOM)/OCP 3.0 slot provides various connectivity options from 10GbE to 200GbE.

The Cisco UCS C240 M8 EDSFF E3.S Rack Server can be used standalone, or as part of the Cisco Unified Computing System, which unifies computing, networking, management, virtualization, and storage access into a single integrated architecture, enabling end-to-end server visibility, management, and control in both bare metal and virtualized environments.

See [Figure 1 on page 3](#) for front and rear views of the UCS C240 M8 EDSFF E3.S Rack Server.

Figure 1 Cisco UCS C240 M8 EDSFF E3.S Rack Server

Front View (all slots shown unpopulated - see [Figure 2 on page 4](#) for details)



Rear View (all slots shown unpopulated - see [Figure 3 on page 5](#) for details)



# DETAILED VIEWS

## Chassis Front View

Figure 2 shows the front view of rack server configured with 32 front drives.

Figure 2 Chassis Front View

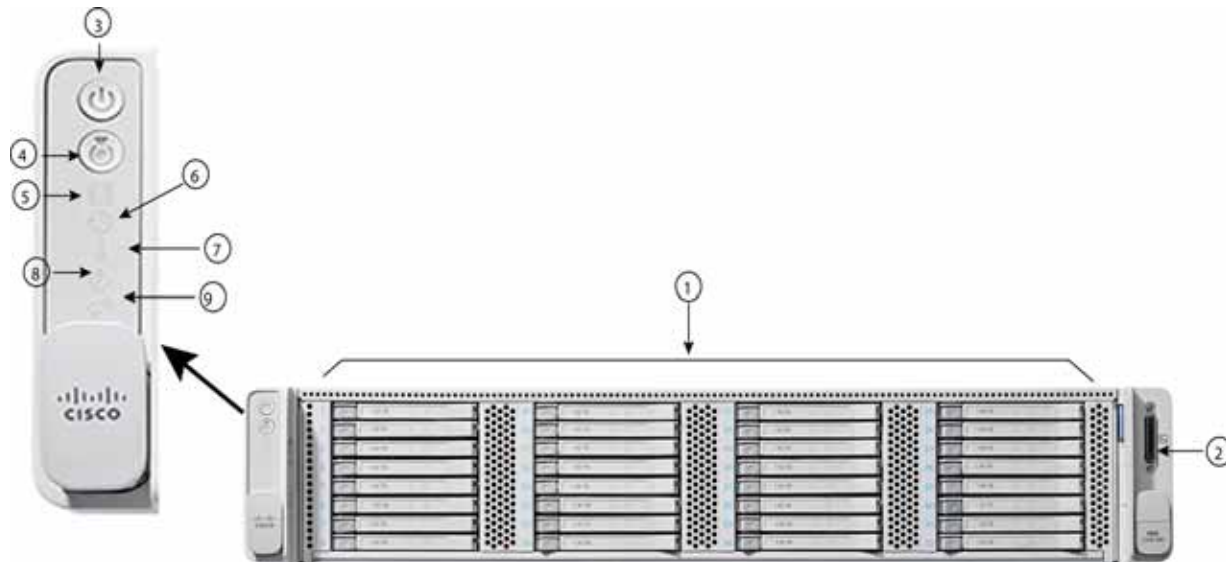

1	Drive bays 1 - 32 support E.3 1T direct attach NVMe	6	Fan status LED
2	KVM connector (used with KVM cable that provides two USB 2.0, one VGA, and one serial connector)	7	Temperature status LED
3	Power button/Power status LED	8	Power supply status LED
4	Unit Identification button/LED	9	Network link activity LED
5	System status LED	-	-

## Chassis Rear View

Figure 3 shows the external features of the rear panel.

Figure 3 Chassis Rear View

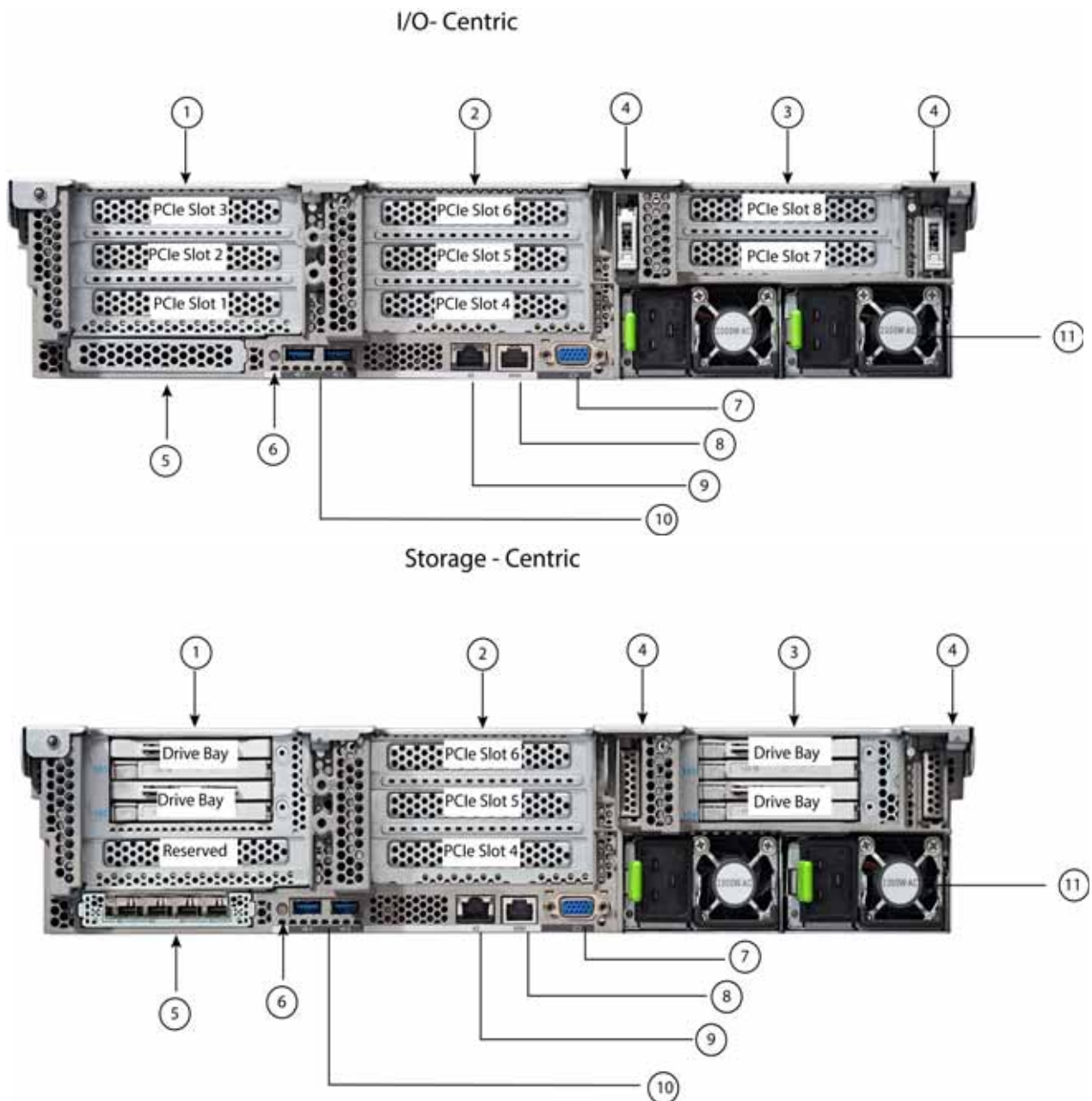

1	<p>There are three Riser 1 options:  <b>Riser 1A (I/O-centric, Gen 5, CPU1 control)</b>                  Supports three Gen 5 PCIe slots:</p> <ul style="list-style-type: none"> <li>■ Slot 1 is full-height, 3/4 length, x8, NCSI, single wide GPU</li> <li>■ Slot 2 is full-height, full-length, x16, NCSI, single/double wide GPU</li> <li>■ Slot 3 is full-height, full-length, x8, no NCSI, single wide GPU</li> </ul> <p><b>Riser 1C (I/O-centric, Gen 5, CPU1 control)</b>                  Supports two Gen 5 PCIe slots:</p> <ul style="list-style-type: none"> <li>■ Slot 1 is full-height, 3/4 length, x16, NCSI, single wide GPU</li> <li>■ Slot 2 is full-height, full-length, x16, no NCSI, single/double wide GPU</li> </ul> <p><b>Riser 1D (Gen 5, CPU1 control)</b>                  Supports two drive bays:</p> <ul style="list-style-type: none"> <li>■ Drive bay 101, x4, E3.S 1T NVMe</li> <li>■ Drive bay 102, x4, E3.S 1T NVMe</li> </ul>	7	VGA display port (DB15 connector)
2	<p>There are two Riser 2 options:  <b>Riser 2A (I/O-centric, Gen 5, CPU2 control)</b>                  Supports three Gen 5 PCIe slots:</p> <ul style="list-style-type: none"> <li>■ Slot 4 is full-height, 3/4 length, x8, NCSI, single wide GPU</li> <li>■ Slot 5 is full-height, full-length, x16, NCSI, single/double wide GPU</li> <li>■ Slot 6 is full-height, full length, x8, no NCSI, single wide GPU</li> </ul> <p><b>Riser 2C (I/O-centric, Gen 5, CPU2 control)</b>                  Supports two Gen 5 PCIe slots:</p> <ul style="list-style-type: none"> <li>■ Slot 4 is full-height, 3/4 length, x16, NCSI, single wide GPU</li> <li>■ Slot 5 is full-height, full-length, x16, no NCSI, single/double wide GPU</li> </ul>	8	COM port (RJ45 connector)
3	<p>There are three Riser 3 options  <b>Riser 3A (I/O-centric, CPU2 control)</b>                  Supports two PCIe slots:</p> <ul style="list-style-type: none"> <li>■ Slot 7 is full-height, full-length, x8, no NCSI, single wide GPU</li> <li>■ Slot 8 is full-height, full-length, x8, no NCSI, single wide GPU</li> </ul> <p><b>Riser 3C (for GPU, CPU2 control)</b>                  Supports one PCIe Slot:</p> <ul style="list-style-type: none"> <li>■ Slot 7 is one full-height, full-length, x16, no NCSI, double wide GPU</li> <li>■ Slot 8 is blocked by double wide GPU (not used)</li> </ul> <p><b>Riser 3D (CPU2 control)</b>                  Supports two drive bays:</p> <ul style="list-style-type: none"> <li>■ Drive bay 103, x4, E3.S 1T NVMe</li> <li>■ Drive bay 104, x4, E3.S 1T NVMe</li> </ul>	9	1 GbE dedicated Ethernet management port
4	Drive bays 243 and 244, support SATA M.2 drives or hot-swappable M.2	10	USB 3.0 ports (two)
5	Modular LAN on motherboard (mLOM)/OCP 3.0 slot or hot-swappable M.2 module (drive bays 241 and 242).	11	Power supplies (two)
6	System ID pushbutton/LED	-	-

## BASE SERVER STANDARD CAPABILITIES and FEATURES

*Table 1* lists the capabilities and features of the base server. Details about how to configure the server for a particular feature or capability (for example, number of processors, disk drives, or amount of memory) are provided in *CONFIGURING the SERVER, page 9*.

Table 1 Capabilities and Features

Capability/Feature	Description
Chassis	Two rack unit (2RU) chassis
CPU	<ul style="list-style-type: none"> <li>■ One or two Intel® Xeon® 6 Scalable Processors</li> <li>■ Each CPU has 8 channels with up to 2 DIMMs per channel, for up to 16 DIMMs per CPU</li> <li>■ UPI Links: Up to 4 at 24GT/s</li> </ul>
Memory	<ul style="list-style-type: none"> <li>■ 32 total DDR5-6400 MT/s DIMM slots with Intel® Xeon® 6 Scalable Processors (16 per CPU)</li> <li>■ Up to 16x MRDIMM 8000MT/s</li> </ul>
Video	<p>The Cisco Integrated Management Controller (CIMC) provides video using the Matrox G200e video/graphics controller:</p> <ul style="list-style-type: none"> <li>■ Integrated 2D graphics core with hardware acceleration</li> <li>■ Embedded DDR memory interface supports up to 512 MB of addressable memory (8 MB is allocated by default to video memory)</li> <li>■ Supports display resolutions up to 1920 x 1200 16bpp @ 60Hz</li> <li>■ High-speed integrated 24-bit RAMDAC</li> <li>■ Single lane PCI-Express host interface running at Gen 1 speed</li> </ul>
Power subsystem	<p>Up to two of the following hot-swappable power supplies:</p> <ul style="list-style-type: none"> <li>■ 1050W (DC)</li> <li>■ 1200W (AC)</li> <li>■ 1600 W (AC)</li> <li>■ 2300 W (AC)</li> </ul> <p>One power supply is mandatory; one more can be added for 1 + 1 redundancy.</p>
Front Panel	A front panel controller provides status indications and control buttons
ACPI	This server supports the advanced configuration and power interface (ACPI) 6.2 standard.
Fans	Six hot-swappable fans for front-to-rear cooling
Expansion slots	<ul style="list-style-type: none"> <li>■ Riser 1A (three Gen 5 PCIe slots)</li> <li>■ Riser 1C (two Gen 5 PCIe slots)</li> <li>■ Riser 1D (two E3.S drive bays)</li> <li>■ Riser 2A (three Gen 5 PCIe slots)</li> <li>■ Riser 2C (two Gen 5 PCIe slots)</li> <li>■ Riser 3A (two Gen 5 PCIe slots)</li> <li>■ Riser 3C (one Gen5 PCIe Slot)</li> <li>■ Riser 3D (two E3.S drive bays)</li> </ul>

Table 1 Capabilities and Features (continued)

Capability/Feature	Description						
Interfaces	<ul style="list-style-type: none"> <li>■ Rear panel:                             <ul style="list-style-type: none"> <li>• One 1Gbase-T RJ-45 management port</li> <li>• One RS-232 serial port (RJ45 connector)</li> <li>• One DB15 VGA connector</li> <li>• Two USB 3.0 port connectors</li> <li>• One flexible modular LAN on motherboard (mLOM)/OCP 3.0 slot that can accommodate various interface cards.</li> </ul> </li> <li>■ Front panel:                             <ul style="list-style-type: none"> <li>• One KVM console connector (supplies two USB 2.0 connectors, one VGA DB15 video connector, and one serial port (RS232) RJ45 connector)</li> </ul> </li> </ul>						
Integrated management processor	<ul style="list-style-type: none"> <li>■ Baseboard Management Controller (BMC) running Cisco Integrated Management Controller (CIMC) firmware.</li> <li>■ Depending on your CIMC settings, the CIMC can be accessed through the 1GE dedicated management port. Cisco virtual interface card (VIC).</li> <li>■ CIMC manages certain components within the server</li> </ul>						
Internal storage devices	<p>Drive storage:</p> <ul style="list-style-type: none"> <li>■ Up to 32 E.3 NVMe solid state drives (SSDs).</li> </ul>  <hr/> <p>Note: Drives are installed into front-panel drive bays, which provide hot-swappable access for E.3 NVMe drives.</p> <p>Other storage:</p> <ul style="list-style-type: none"> <li>■ A Boot Optimized RAID Controller supports                             <ul style="list-style-type: none"> <li>• Up to two internal SATA M.2 SSDs, or</li> <li>• Up to two rear-accessible hot-swappable SATA M.2 SSDs</li> </ul> </li> <li>■ 8GB FlexMMC utility storage for staging of firmware and other user data. 8GB FlexMMC storage is built into the motherboard on M8.</li> </ul>						
Modular LAN on Motherboard (mLOM)/ Open Compute Project (OCP) 3.0 slot	<p>The dedicated mLOM/Open Compute Project (OCP) 3.0 slot on the motherboard can flexibly accommodate the following cards:</p> <ul style="list-style-type: none"> <li>■ Cisco Virtual Interface Cards</li> <li>■ Open Compute Project (OCP) 3.0 network interface card</li> </ul>						
Fabric Interconnect	<ul style="list-style-type: none"> <li>■ Compatible with the Cisco UCS 6400, 6500, 6600 Series and UCSX-S9108-100G fabric interconnects.</li> <li>■ In addition to direct-connect of rack-server to the Fabric Interconnect, the rack-server can also connect via the “Nexus 93180YC-FX3 FEX” for having up to 160 servers behind a pair of Fabric Interconnect.</li> </ul>						
CIMC	Cisco Integrated Management Controller 4.3(6) or later						
Intersight	Intersight provides server management capabilities						
Firmware standards	<table border="0"> <tr> <td>UEFI Spec</td> <td>2.9</td> </tr> <tr> <td>ACPI</td> <td>6.5</td> </tr> <tr> <td>SMBIOS Ver</td> <td>3.7</td> </tr> </table>	UEFI Spec	2.9	ACPI	6.5	SMBIOS Ver	3.7
UEFI Spec	2.9						
ACPI	6.5						
SMBIOS Ver	3.7						

# CONFIGURING the SERVER

Follow these steps to configure the Cisco UCS C240 M8 EDSFF E3.S Rack Server:

- *STEP 1 SELECT SERVER SKU, page 10*
- *STEP 2 SELECT MANAGEMENT MODE (REQUIRED), page 11*
- *STEP 3 SELECT RISER CARDS (REQUIRED), page 12*
- *STEP 4 SELECT CPU(s) (REQUIRED), page 14*
- *STEP 5 SELECT MEMORY (REQUIRED), page 17*
- *STEP 6 SELECT DRIVE CONTROLLERS, page 21*
- *STEP 7 SELECT DRIVE CABLING OPTIONS (REQUIRED), page 22*
- *STEP 9 SELECT OPTION CARD(s) (OPTIONAL), page 24*
- *STEP 10 ORDER GPU CARDS (OPTIONAL), page 29*
- *STEP 11 ORDER M.2 BOOT RAID CONTROLLER and SATA SSDs (OPTIONAL), page 31*
- *STEP 12 ORDER POWER SUPPLY (REQUIRED), page 33*
- *STEP 13 SELECT INPUT POWER CORD(s) (REQUIRED), page 34*
- *STEP 14 ORDER TOOL-LESS RAIL KIT (REQUIRED) AND REVERSIBLE CABLE MANAGEMENT ARM (OPTIONAL), page 38*
- *STEP 15 SELECT MANAGEMENT CONFIGURATION (OPTIONAL), page 39*
- *STEP 16 ORDER SECURITY DEVICES (REQUIRED), page 40*
- *STEP 17 SELECT LOCKING SECURITY BEZEL (OPTIONAL), page 41*
- *STEP 18 SELECT OPERATING SYSTEM, page 42*
- *STEP 19 CISCO INTERSIGHT, page 45*
- *SUPPLEMENTAL MATERIAL, page 47*

## STEP 1 SELECT SERVER SKU

Top level ordering product ID (PID) is shown in [Table 2](#).

Table 2 Top Level Major Line Bundle ordering PIDs (MLB)

Product ID (PID)	Description
UCS-M8-MLB	UCS M8 RACK MLB This major line bundle (MLB) consists of the Rack Server (UCSC-C240-M8SX, UCSC-C240-M8L or UCSC-C240-M8E3S) with software PIDs. Use this PID to begin a new configuration.

Select one product ID (PID) as shown in [Table 3](#).



**CAUTION:** This product may not be purchased outside of the approved bundles (must be ordered under the MLB)

Table 3 PID of the Rack Base Server

Product ID (PID)	Description
UCSC-C240-M8E3S	<ul style="list-style-type: none"> <li>■ E3.S 1T Form Factor drives, with 32-drive backplane.</li> <li>■ Front facing drive bays 1-32 support E.3 1T direct attached NVMe SSDs</li> </ul>

The Cisco UCS C240 M8 EDSFF E3.S Rack Server:

- Includes a 32 drive backplane.
- Does not include power supply, CPU, memory, hard disk drives (HDDs), solid-state drives (SSDs), NVMe drives, SD cards, riser 1, riser 2, riser 3, tool-less rail kit, or PCIe cards.
- Use the steps on the following pages to configure the server with the components that you want to include.

## STEP 2 SELECT MANAGEMENT MODE (REQUIRED)

The available management modes are listed in [Table 4](#).

Table 4 Management Mode

Product ID (PID)	Description
IMM-MANAGED	Deployment mode for UCS FI connected Servers in IMM mode
UMM-MANAGED	Deployment mode for UCS FI connected Servers in UCSM mode
ISM-MANAGED	Deployment mode for C Series Servers in Standalone mode



**NOTE:** Cisco UCS M8 servers are the last generation to support UCS Manager (UCSM). Any customers choosing to use UCSM with M8 servers should proactively plan to transition to IMM by 2027

### STEP 3 SELECT RISER CARDS (REQUIRED)

Select desired risers from [Table 5](#).

Table 5 PIDs of the Risers

Product ID (PID)	Description
<b>Riser 1 Options</b>	
UCSC-RIS1A-240M8 (I/O riser)	UCS C240 M8 Riser 1A PCIe Gen5 (x8, x16, x8) <ul style="list-style-type: none"> <li>■ Slot 1 is full-height, 3/4 length, x8, Supports NCSI and single wide GPU</li> <li>■ Slot 2 is full-height, full-length, x16, Supports NCSI and single/double wide GPU</li> <li>■ Slot 3 is full-height, full-length, x8, Supports single wide GPU</li> </ul>
UCSC-RIS1C-240M8 (I/O riser)	UCS C240 M8 Riser 1C PCIe Gen5 (2x16) FH <ul style="list-style-type: none"> <li>■ Slot 1 is full-height, 3/4 length, x16, Supports NCSI and single wide GPU</li> <li>■ Slot 2 is full-height, full-length, x16, supports single/double wide GPU</li> </ul>
UCSC-RIS1D-240M8 (storage riser)	UCS C240 M8 Riser 1D support 2x E3.S 1T drives <ul style="list-style-type: none"> <li>■ Drive bay 102, x4, E3.S 1T NVMe drives</li> <li>■ Drive bay 101, x4, E3.S 1T NVMe drives</li> </ul>
<b>Riser 2 Options (2-CPU must be selected)</b>	
UCSC-RIS2A-240M8 (I/O riser)	UCS C240 M8 Riser 2A PCIe Gen5 (x8, x16, x8) (controlled with CPU2) <ul style="list-style-type: none"> <li>■ Slot 4 is full-height, 3/4 length, x8, Supports NCSI and single wide GPU</li> <li>■ Slot 5 is full-height, full-length, x16, Supports NCSI and single/double wide GPU</li> <li>■ Slot 6 is full-height, full length, x8, Supports single wide GPU</li> </ul>
UCSC-RIS2C-240M8 (I/O riser)	UCS C240 M8 Riser 2C PCIe Gen5 (2x16) (controlled with CPU2) <ul style="list-style-type: none"> <li>■ Slot 4 is full-height, 3/4 length, x16, Supports NCSI and single wide GPU</li> <li>■ Slot 5 is full-height, full-length, x16, Supports single/double wide GPU</li> </ul>
<b>Riser 3 Options (2-CPU must be selected)</b>	
UCSC-RIS3A-240M8 (I/O riser)	UCS C240 M8 Riser 3A PCIe Gen5 (controlled with CPU2) <ul style="list-style-type: none"> <li>■ Slot 7 is full-height, full-length, x8</li> <li>■ Slot 8 is full-height, full-length, x8</li> </ul>
UCSC-RIS3C-240M8	UCS C240 M8 Riser 3C PCIe Gen5 (x16) (controlled with CPU2) <ul style="list-style-type: none"> <li>■ Slot 7 is one full-height, full-length, x16, Supports double wide GPU</li> <li>■ Slot 8 is blocked by double wide GPU (not used)</li> </ul>
UCSC-RIS3D-240M8 (storage riser)	UCS C240 M8 Riser 3D support 2x E3.S 1T drives (CPU2) <ul style="list-style-type: none"> <li>■ Drive bay 103, x4, E3.S 1T NVMe drives</li> <li>■ Drive bay 104, x4, E3.S 1T NVMe drives</li> </ul>
Accessories/spare included along with selected risers: <ul style="list-style-type: none"> <li>■ UCSC-FBRS2-C240-D for riser 2 and UCSC-FBRS3-C245 riser filler blank for riser 3 is auto included, if riser 2 or riser 3 are not selected.</li> </ul>	
<b>NOTE:</b> Please note, if you are adding additional risers later, you may need to order the accessories with it.	



NOTE: For GPU support on a particular riser slot, see [Table 13 on page 29](#)

---

## STEP 4 SELECT CPU(s) (REQUIRED)

The standard CPU features are:

- Up to 86 cores
- Cache size of up to 336 MB
- Power: Up to 350 Watts
- UPI Links: Up to 4 at 24GT/s

Select CPUs from [Table 6](#)



**CAUTION:**

- Normal operating temperature is limited to 35° C [95° F], and is lowered to 28° C [82.4° F], with a fan fault. When rear drives are installed, the normal operating temperature is lowered to 30° C [86° F], and 26° C [78.8° F], respectively with a fan fault.
- With multiple GPU>75W installed, normal operating temperature is 30° C [86° F], lowered to 25° C [77° F], with a fan fault.
- When a GPU>75W is installed, CPUs with TDP greater than 330W are not supported

Table 6 Available Intel® Xeon® 6 Scalable CPUs

Product ID	Segment/ Workload	Maximum Socket	Cores	Clock Freq	Power	Cache Size	Highest DDR5 DIMM Clock	MRDIMM Support
(PID)		(S)	(C)	(GHz)	(W)	(MB)	(MT/s)	
UCS-CPU-I6787P	Performance	2S	86	2.00	350	336	6400	Yes
UCS-CPU-I6781P <sup>1</sup>	Single Socket	1S	80	2.00	350	336	6400	Yes
UCS-CPU-I6767P	Performance	2S	64	2.40	350	336	6400	Yes
UCS-CPU-I6761P <sup>1</sup>	Single Socket	1S	64	2.50	350	336	6400	Yes
UCS-CPU-I6760P	Mainline	2S	64	2.20	330	320	6400	No
UCS-CPU-I6747P	Performance	2S	48	2.70	330	288	6400	Yes
UCS-CPU-I6741P <sup>1</sup>	Single Socket	1S	48	2.50	300	288	6400	No
UCS-CPU-I6740P	Mainline	2S	48	2.10	270	288	6400	No
UCS-CPU-I6736P	Performance	2S	36	2.00	205	144	6400	No
UCS-CPU-I6745P	Performance	2S	32	3.10	300	336	6400	No
UCS-CPU-I6737P	Performance	2S	32	2.90	270	144	6400	No
UCS-CPU-I6731P <sup>1</sup>	Single Socket	1S	32	2.50	245	144	6400	No
UCS-CPU-I6730P	Performance	2S	32	2.50	250	288	6400	No

Table 6 Available Intel® Xeon® 6 Scalable CPUs

Product ID	Segment/ Workload	Maximum Socket	Cores	Clock Freq	Power	Cache Size	Highest DDR5 DIMM Clock	MRDIMM Support
(PID)		(S)	(C)	(GHz)	(W)	(MB)	(MT/s)	
UCS-CPU-I6530P	Mainline	2S	32	2.30	225	144	6400	No
UCS-CPU-I6728P	Socket scalable	2S	24	2.70	210	144	6400	No
UCS-CPU-I6527P	Performance	2S	24	3.00	255	144	6400	No
UCS-CPU-I6521P <sup>1</sup>	Single Socket	1S	24	2.60	225	144	6400	No
UCS-CPU-I6520P	Mainline	2S	24	2.40	210	144	6400	No
UCS-CPU-I6511P <sup>1</sup>	Single Socket	1S	16	2.50	150	72	6400	No
UCS-CPU-I6724P	Performance	2S	16	3.60	210	72	6400	No
UCS-CPU-I6517P	Performance	2S	16	3.20	190	72	6400	No
UCS-CPU-I6515P	Mainline	2S	16	2.30	150	72	6400	No
UCS-CPU-I6505P	Mainline	2S	12	2.20	150	48	6400	No
UCS-CPU-I6714P	Performance	2S	8	4.00	165	48	6400	No
UCS-CPU-I6507P	Performance	2S	8	3.50	150	48	6400	No

Accessories/spare included with CPU configuration:

- UCSC-HSLP-C240M8
- UCSC-HSLP-C220M8 if UCSC-GPUAD-240M8 is selected

NOTE: if you are adding a second CPU later, you may need to order accessories spares with it.

## Notes:

1. Single Socket only CPUs

Table 7 CPU PID Decoder

Identifier#1	Identifier#2	Identifier#3	Identifier#4	Identifier#5	Identifier#6	Identifier#7
Cisco Product Family	CPU supplier	CPU Generation	SKU Tier	CPU SKU (2 digits)	Core Architecture	Option/Spare CPU
UCS	I: Intel	6: 6th Generation	5: GNR-SP Mid Tier 7: GNR-SP High Tier	Examples: 20, 34, 48 See detailed SKUs stack from supplier 11, 21, 31, 41, 61, 81: single-socket	P: P-Core	Blank: Option =: Spare

## Supported Configurations

---

- 1-CPU Configuration:
  - Choose one CPU from [Table 6](#)
- 2-CPU Configuration:
  - Choose two identical CPUs from [Table 6](#)

The selection of 1 or 2 CPUs depends on the desired server functionality. See the following sections:

- [STEP 3 SELECT RISER CARDS \(REQUIRED\), page 12](#)
- [STEP 5 SELECT MEMORY \(REQUIRED\), page 17](#)
- [STEP 6 SELECT DRIVE CONTROLLERS, page 21](#)
- [STEP 7 SELECT DRIVE CABLING OPTIONS \(REQUIRED\), page 22](#)
- [STEP 8 SELECT DRIVES \(OPTIONAL\), page 23](#)
- [STEP 9 SELECT OPTION CARD\(s\) \(OPTIONAL\), page 24](#)

## STEP 5 SELECT MEMORY (REQUIRED)

The [Table 8](#) below describes the main memory DIMM features supported on the server.

Table 8 Server Main Memory Features

Memory server technologies	Description	
	DIMM	MRDIMM <sup>1</sup>
Intel® Xeon® CPU generation	Intel® Xeon® 6 CPUs	
DDR5 memory clock speed	Up to 6400 MT/s 1DPC; Up to 5200 MT/s 2DPC	Up to 8000 MT/s 1DPC
Operational voltage	1.1 Volts	
DRAM fab density	16Gb, 24Gb and 32Gb	16Gb
Memory type	RDIMM (Registered DDR5 DIMM)	MRDIMM (Multiplexed Rank DDR5 DIMM)
Memory DRAM DIMM/MRDIMM organization	Eight memory DIMM channels per CPU; up to 2 DIMMs Per Channel	Eight MRDIMM channels per CPU; 1 DIMM Per Channel
Maximum number of DRAM DIMM/MRDIMM per server	32 (2-Socket)	16 (2-Socket)
DRAM DIMM/MRDIMM Densities and Ranks	16GB 1Rx8, 32GB 1Rx4, 32GB 2Rx8, 48GB 1Rx4, 64GB 2Rx4, 96GB 2Rx4, 128GB 2Rx4, 256GB 4Rx4	32GB 2Rx8, 64GB 2Rx4
Maximum system memory capacity	8TB (32x256GB)	1TB (16x64GB)

Notes:

1. Intel® Xeon® 6 SKUs 6787P, 6781P, 6767P, 6761P, and 6747P support MRDIMM, Per Intel® Xeon® 6 documentation.

Figure 4 Memory Organization

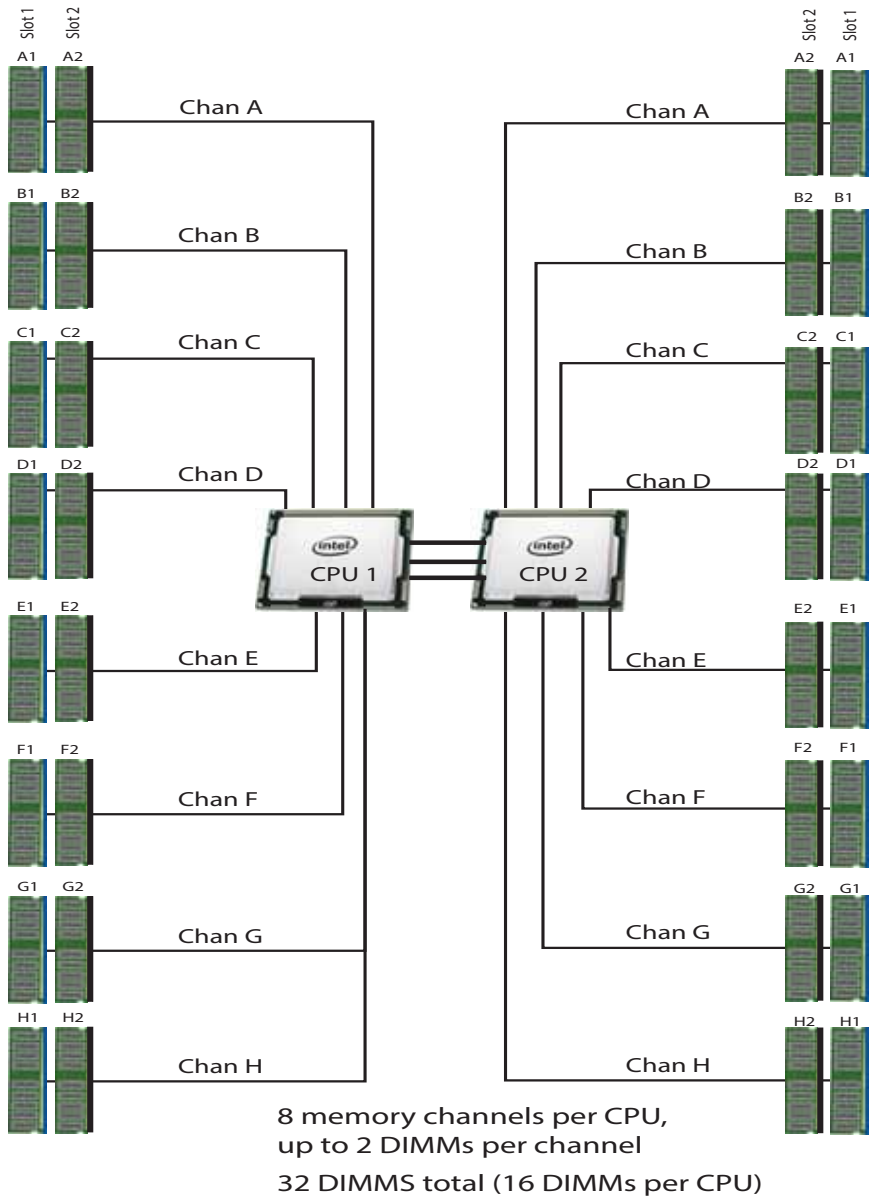

## Select DIMMs and Memory Mirroring

Select the memory configuration and whether or not you want the memory mirroring option. The available memory DIMMs and mirroring option are listed in [Table 9](#).



**NOTE:** When memory mirroring is enabled, the memory subsystem simultaneously writes identical data to two channels. If a memory read from one of the channels returns incorrect data due to an uncorrectable memory error, the system automatically retrieves the data from the other channel. A transient or soft error in one channel does not affect the mirrored data, and operation continues unless there is a simultaneous error in exactly the same location on a DIMM and its mirrored DIMM. Memory mirroring reduces the amount of memory available to the operating system by 50% because only one of the two populated channels provides data.



**CAUTION:** On C240 M8, when 256GB DIMMs are configured in the server, ambient temperature is limited to a maximum 30°C. 256GB DIMMs cannot be used in systems with GPUs > 75 Watts.

Table 9 Memory Options for UCS M8 servers with Intel® Xeon® 6th Gen. CPUs

Product ID (PID)	PID Description	Ranks/DIMM
<b>DDR5-6400 MT/s Cisco Memory PIDs list</b>		
UCS-MRX16G1RE5	16GB RDIMM 1Rx8 1.1Volts (16Gb)	1
UCS-MRX32G1RE5	32GB RDIMM 1Rx4 1.1Volts (16Gb)	1
UCS-MRX32G2RE5	32GB RDIMM 2Rx8 1.1Volts (16Gb)	2
UCS-MRX48G1RF5	48GB RDIMM 1Rx4 1.1Volts (24Gb)	1
UCS-MRX64G2RE5	64GB RDIMM 2Rx4 1.1Volts (16Gb)	2
UCS-MRX96G2RF5	96GB RDIMM 2Rx4 1.1Volts (24Gb)	2
UCS-MR128G2RG5	128GB RDIMM 2Rx4 1.1Volts (32Gb)	2
UCS-MR256G4RG5	256GB RDIMM 4Rx4 1.1Volts (32Gb)	4
<b>DDR5 MRDIMM-8800 MT/s Cisco Memory PIDs list</b>		
UCS-MCX32G2RE11 <sup>1</sup>	32GB DDR5 MRDIMM 8800 2Rx8 (16Gb)	2
UCS-MCX64G2RE11 <sup>1</sup>	64GB DDR5 MRDIMM 8800 2Rx4 (16Gb)	2
<b>Memory Mirroring Option</b>		
N01-MMIRRORD	Memory mirroring option	
<b>Accessories/spare included with Memory configuration:</b>		
<ul style="list-style-type: none"> <li>■ UCS-DDR5-BLK<sup>1</sup> is auto included for the unselected DIMMs slots</li> </ul>		

**Notes:**

1. Any empty DIMM slot must be populated with a DIMM blank to maintain proper cooling airflow.

## Memory configurations and mixing rules

- Golden Rule: Memory on every CPU socket shall be configured identically.
- For full details on supported memory configurations, count rules, population rules and mixing rules see the [Intel M8 Memory guide](#)

## STEP 6 SELECT DRIVE CONTROLLERS

---



NOTE: There is no raid controller support for this Server

---

## STEP 7 SELECT DRIVE CABLING OPTIONS (REQUIRED)

Select desired drive cabling from [Table 10](#)



**NOTE:** Once configured, drive cabling options are not field upgradable.

Table 10 Available drive cabling options

Product ID (PID)	PID Description	# of drives supported	Per Drive connection	Available PCIe risers	Type
UCSC-240M8E3-32X2	C240M8 E3.S 32 drives (x2 lanes) with riser 1,2&3	32	PCIe Gen5 x2	Riser 1, 2 & 3	Capacity & I/O Optimized
UCSC-240M8E3-16X4	C240M8 E3.S 16 drives (x4 lanes, slots 9-24) with riser 1,2&3	16	PCIe Gen5 x4	Riser 1, 2 & 3	Performance Optimized
UCSC-240M8E3-24X4	C240M8 E3.S 24 drives (x4 lanes) with riser 1 and 3 only	24	PCIe Gen5 x4	Riser 1 & 3 only	Performance Optimized
UCSC-240M8E3-32X4	C240M8 E3.S 32 drives (x4 lanes) with riser 3 only	32	PCIe Gen5 x4	Riser 3 only	Performance Optimized
<b>Accessories/spare included with drives</b> <ul style="list-style-type: none"> <li>■ CBL-E3SX2-2UM8-P1, CBL-E3SX2-2UM8-P2, CBL-E3SX2-2UM8-P3 (2CPU) and CBL-E3SX2-2UM8-P4 (2CPU) are auto included with UCSC-240M8E3-32X2</li> <li>■ CBL-E3SX4-2UM8-P1, CBL-E3SX4-2UM8-P2, CBL-E3SX4-2UM8-P3, CBL-E3SX4-2UM8-P4 are auto included with UCSC-240M8E3-16X4</li> <li>■ CBL-RIS2E-240M8, UCSC-RIS2E-240M8, and all above accessories included with UCSC-240M8E3-16X4, are auto included with UCSC-240M8E3-24X4</li> <li>■ CBL-RIS1E-240M8, UCSC-RIS1E-240M8, and all above accessories included with UCSC-240M8E3-24X4, are auto included with UCSC-240M8E3-32X4</li> </ul>					

### Caveats

- Performance Optimized Cabling Options (UCSC-240M8E3-16X4, UCSC-240M8E3-24X4, UCSC-240M8E3-32X4) are supported with 2 CPU configurations only.
- When Performance Optimized Cabling Options (UCSC-240M8E3-24X4, UCSC-240M8E3-32X4) are selected, rear storage riser 1D and 3D are not supported.
- When UCSC-240M8E3-24X4 is selected, rear riser 2 (2A or 2C) is not supported.
- When UCSC-240M8E3-32X4 is selected, rear riser 1 (1A, 1C or 1D) and 2 (2A or 2C) are not supported.

## STEP 8 SELECT DRIVES (OPTIONAL)

The standard disk drive features are:

- E3.S 1T NVMe Drives
- Hot-pluggable
- Drives come mounted in sleds

### Select Drives

- The available drives listed [Table 11](#)

Table 11 Available E3.S 1T NVMe Drives

Product ID (PID)	PID Description	Speed	Capacity
UCS-NVE112T8K1P	12.8TB E3.S1T KCD8XPJE HgPerf HgEnd Gen5 3X NVMe (SIE SCEF)	3X	12.8 TB
UCS-NVE115T3K1V	15.3TB E3.S1T KCD8XPJE HgPerf MedEnd Gen5 1X NVMe (SIE SCEF)	1X	15.3 TB
UCS-NVE111T6K1P	1.6TB E3.S1T KCD8XPJE HgPerf HgEnd Gen5 3X NVMe (SIE SCEF)	3X	1.6 TB
UCS-NVE111T9K1V	1.9TB E3.S1T KCD8XPJE HgPerf MedEnd Gen5 1X NVMe (SIE SCEF)	1X	1.9 TB
UCS-NVE13T2K1P	3.2TB E3.S1T KCD8XPJE HgPerf HgEnd Gen5 3X NVMe (SIE SCEF)	3X	3.2 TB
UCS-NVE13T8K1V	3.8TB E3.S1T KCD8XPJE HgPerf MedEnd Gen5 1X NVMe (SIE SCEF)	1X	3.8 TB
UCS-NVE16T4K1P	6.4TB E3.S1T KCD8XPJE HgPerf HgEnd Gen5 3X NVMe (SIE SCEF)	3X	6.4 TB
UCS-NVE17T6K1V	7.6TB E3.S1T KCD8XPJE HgPerf MedEnd Gen5 1X NVMe (SIE SCEF)	1X	7.6 TB
UCS-NVE111T6S1P	1.6TB E3.S1T PM1745 HgPerf HgEnd Gen5 3X NVMe (TCG OPAL)	3X	1.6 TB
UCS-NVE13T2S1P	3.2TB E3.S1T PM1745 HgPerf HgEnd Gen5 3X NVMe (TCG OPAL)	3X	3.2 TB
UCS-NVE16T4S1P	6.4TB E3.S1T PM1745 HgPerf HgEnd Gen5 3X NVMe (TCG OPAL)	3X	6.4 TB
UCS-NVE112T8S1P	12.8TB E3.S1T PM1745 HgPerf HgEnd Gen5 3X NVMe (TCG OPAL)	3X	12.8 TB
UCS-NVE111T9S1V	1.9TB E3.S1T PM1743 HgPerf MedEnd Gen5 1X NVMe (TCG OPAL)	1X	1.9 TB
UCS-NVE13T8S1V	3.8TB E3.S1T PM1743 HgPerf MedEnd Gen5 1X NVMe (TCG OPAL)	1X	3.8 TB
UCS-NVE115T3S1V	15.3TB E3.S1T PM1743 HgPerf MedEnd Gen5 1X NVMe (TCG OPAL)	1X	15.3 TB
<b>Accessories/spare included with drives</b>			
<ul style="list-style-type: none"> <li>■ UCSC-E3S1T-F is included for the not selected front storage device.</li> <li>■ If you are adding drive later as spare, you may need to order cables with it.</li> </ul>			

## STEP 9 SELECT OPTION CARD(S) (OPTIONAL)

For up-to-date server compatibility, please check the Hardware and Software compatibility list (HCL) at <https://ucshcltool.cloudapps.cisco.com/public/>.

The standard PCIe card offerings are:

- Modular LAN on Motherboard (mLOM)
- Open Compute Project (OCP) 3.0
- Virtual Interface Cards (VICs)
- Network Interface Cards (NICs)
- Host Bus Adapters (HBAs)

### Select Option Cards



**NOTE:**

- If a double-wide (DW) GPU is selected in Riser 1 Slot 2, it blocks the use of Riser 1 Slot 3; similarly, if a DW GPU is selected in Riser 2 Slot 5, it blocks Riser 2 Slot 6, preventing simultaneous selection of these adjacent PCIe slots
- Refer to [Cisco UCS C240 M8 Installation Guide](#) more info



**CAUTION:**

- When UCSC-P-N3140H are installed, normal operating temperature is 28°C [82.4°F], lowered to 24°C [75.2°F] with a fan fault.
- When UCSC-P-N7S400GFO or UCSC-P-N7S400GF is installed, normal operating temperature is 28°C [82.4°F], lowered to 22°C [71.6°F] with a fan fault.

The available option cards are listed in [Table 12](#)

Table 12 Available PCIe Option Cards

Product ID (PID)	PID Description	Location	Card Size <sup>1</sup>
<b>Modular LAN on Motherboard (mLOM)<sup>2</sup></b>			
UCSC-M-V5Q50GV2-D	Cisco VIC 15427 4x 10/25/50G mLOM C-Series w/Secure Boot	mLOM	HHHL, SS
UCSC-M-V5D200GV2D	Cisco VIC 15237 2x 40/100/200G mLOM C-Series w/Secure Boot	mLOM	HHHL, SS
<b>Open Compute Project (OCP)<sup>3</sup></b>			
UCSC-O-ID10GC-D	Intel X710T2LOCPV3G1L 2x10GbE RJ45 OCP3.0 NIC	OCP	SFF
UCSC-O-N6CD25GFO	NVIDIA OEM MCX631432AC-ADAB CX6Lx 2x25G SFP28 x8 OCP NIC	OCP	SFF
UCSC-O-N6CD100GFO	NVIDIA OEM MCX623436AC-CDAB CX6Dx 2x100G QSFP56 x16 OCP NIC	OCP	SFF
<b>Virtual Interface Cards (VICs)<sup>2,4</sup></b>			

Table 12 Available PCIe Option Cards (*continued*)

Product ID (PID)	PID Description	Location	Card Size <sup>1</sup>
UCSC-P-V5Q50G-D	Cisco VIC 15425 4x 10/25/50G PCIe C-Series w/Secure Boot	Riser 1 or 3	HHHL, SS
UCSC-P-V5D200G-D	Cisco VIC 15235 2x 40/100/200G PCIe C-Series w/Secure Boot	Riser 1 or 3	HHHL, SS
<b>Network Interface Cards (NICs)</b>			
<b>1GbE NICs</b>			
UCSC-P-IQ1GC	Cisco-Intel I710-T4L 4x1GBASE-T NIC	Riser 1, 2, or 3	HHHL, SS
<b>10GbE NICs</b>			
UCSC-P-ID10GC-D	Cisco-Intel X710T2LG 2x10GBE RJ45 PCIe NIC	Riser 1, 2, or 3	HHHL, SS
UCSC-P-IQ10GC-D	Cisco-Intel X710T4LG 4x10GBE RJ45 PCIe NIC	Riser 1, 2, or 3	HHHL, SS
<b>25GbE NICs</b>			
UCSC-P-I8D25GF-D	Cisco-Intel E810XXVDA2 2x25/10GBE SFP28 PCIe NIC	Riser 1, 2, or 3	HHHL, SS
UCSC-P-N6D25GFO	NVIDIA OEM MCX631102AS-ADAT CX6Lx 2x25GbE SFP28 x8 PCIe NIC	Riser 1, 2, or 3	HHHL, SS
UCSC-P-N7Q25GF	CX713104AS-ADAT: 4x25GbE SFP56 Gen4x16, PCIe NIC	Riser 1, 2, or 3	HHHL, SS
UCSC-P-I8Q25GF-D	Cisco-Intel E810XXVDA4L 4x25/10 GbE SFP28 PCIe NIC	Riser 1, 2, or 3	FHHL, SS
UCSC-P-N7Q25GFO	NVIDIA OEM CX713104AS-ADAT: 4x25GbE SFP56 Gen4x16, PCIe NIC	Riser 1, 2, or 3	HHHL, SS
<b>100GbE NICs</b>			
UCSC-P-M6CD100GFO	NVIDIA OEM MCX623106AC-CDAT, 2x100 GbE QSFP56 PCIe Crypto	Riser 1, 2, or 3	HHHL, SS
UCSC-P-M6DD100GFO	NVIDIA OEM MCX623106AS-CDAT, 2x100 GbE QSFP56 PCIe No Crypto	Riser 1, 2, or 3	HHHL, SS
UCSC-P-I8D100GF-D	Cisco-Intel E810CQDA2 2x100 GbE QSFP28 PCIe NIC	Riser 1, 2, or 3	HHHL, SS
<b>200GbE NICs</b>			
UCSC-P-N7D200GF	MCX755106AS-HEAT: CX-7 2x200GbE QSFP112 PCIe Gen5x16, VPI NIC	Riser 1, 2, or 3	HHHL, SS
UCSC-P-N7D200GF	MCX755106AS-HEAT: CX-7 2x200GbE QSFP112 PCIe Gen5x16, VPI NIC	Riser 1, 2, or 3	HHHL, SS
UCSC-P-N7D200GFO	NVIDIA OEM MCX755106AS-HEAT 2x200GbE QSFP112 PCIe Gen5 NIC	Riser 1, 2, or 3	HHHL, SS
UCSC-P-N3220L	Nvidia OEM BlueField-3 B3220L SuperNIC 2x200G	Riser 1, 2, or 3	FHHL, SS
UCSC-P-N3220	Nvidia OEM BlueField-3 B3220 DPU 2x200G	Riser 1, 2, or 3	FHHL, SS
UCSC-P-NC3220L	Nvidia Crypto B3220L SuperNIC 2x200GbE/IB QSFP112 Gen5 FHHL	Riser 1, 2, or 3	FHHL, SS
UCSC-P-NC3220	Nvidia Crypto B3220 DPU 2x200GbE/IB QSFP112 Gen5x16 FHHL	Riser 1, 2, or 3	FHHL, SS
<b>400GbE NICs</b>			
UCSC-P-N7S400GF <sup>5</sup>	MCX715105AS-WEAT CX-7 1x400GbE QSFP112 PCIe Gen5 x16 VPI NIC	Riser 1, 2, or 3	HHHL, SS
UCSC-P-N7S400GFO <sup>5</sup>	NVIDIA OEM MCX715105AS-WEAT 1x400GbE QSFP112 PCIe Gen5 NIC	Riser 1, 2, or 3	HHHL, SS
UCSC-P-N3140H <sup>6</sup>	Nvidia OEM BlueField-3 B3140H SuperNIC 1x400G	Riser 2	HHHL, SS

Table 12 Available PCIe Option Cards (continued)

Product ID (PID)	PID Description	Location	Card Size <sup>1</sup>
<b>Host Bus Adapters (HBAs)</b>			
UCSC-P-Q6D32GF-D	Cisco-QLogic QLE2772 2x32GFC Gen 6 Enhanced PCIe HBA	Riser 1, 2, or 3	HHHL, SS
UCSC-P-B7D32GF-D	Cisco-Emulex LPe35002-M2-2x32GFC Gen 7 PCIe HBA	Riser 1, 2, or 3	HHHL, SS
UCSC-PCIEBD16GF-D	Emulex LPe31002 dual port 16G FC HBA	Riser 1, 2, or 3	HHHL, SS
UCSC-P-Q7D64GF	Cisco-QLogic QLE2872, 2x64GFC Gen 7 PCIe HBA	Riser 1, 2, or 3	HHHL, SS
<b>Accessories/spare included with PCI Card.</b>			
<ul style="list-style-type: none"> <li>■ UCSC-OCP3-KIT-D is included along with the selection Open Compute Project (OCP) card</li> </ul>			

Notes:

1. HHHL = half-height, half-length; FHHL = full-height, half-length; SS = single-slot; DS = double-slot. SFF = small form factor.
2. 50G speed on the 4-port and 200G speed on the 2-port are only supported on standalone servers with supported cables. Please refer to the [VIC 15000 series datasheet](#) for supported switches and cables.
3. For installation in the mLOM slot, you can order either an mLOM VIC, or the OCP NIC - but not both. If ordering the OCP NIC, the OCP Mechanical Kit (UCSC-OCP3-KIT) must also be installed in order to mount OCP NIC in the mLOM slot.
4. This Virtual Interface Cards incorporate VIC Secure Boot technology.
5. - **Maximum Quantity:** You can install up to 3 cards per server, specifically in riser 1A/1C (slot 2), riser 2A/2C (slot 5), and riser 3C (slot 7).
  - **CPU Restrictions:** CPUs with a Thermal Design Power (TDP) exceeding 330W are not supported when these cards are installed.
  - **Memory (256GB):** 256GB DIMMs are not supported in this configuration.
  - **Memory (128GB):** 128GB DIMMs are supported only at 1 DIMM Per Channel (1DPC), with a maximum limit of 8 DIMMs per CPU.
  - **Operating Temperature:** The standard operating temperature is 28°C (82.4°F). This must be reduced to 25°C (77°F) if a fan fault occurs.
6. config rules:
  - **Maximum Support:** Only one UCSC-P-N3140H is supported per server, installed in riser 2A/2C, slot 5.
  - **Cabling Compatibility:** Only the UCSC-240M8E3-16X4 drive cabling option is supported. Other configurations, such as UCSC-240M8E3-32X2, UCSC-240M8E3-24X4, or UCSC-240M8E3-32X4, are not supported.
  - **Memory (256GB):** 256GB DIMMs are not supported with this configuration.
  - **Memory (128GB):** 128GB DIMMs are supported only at 1 DIMM Per Channel (1DPC), with a maximum of 8 DIMMs per CPU.
  - **Operating Temperature:** The standard operating temperature is 28°C (82.4°F). This limit is reduced to 22°C [71.6°F] if a fan fault occurs.

Caveats

- For 1-CPU systems:
  - All the PCIe slots on riser 1A and 1C are supported for the PCIe Cards.
  - Riser 2 and 3 are not supported in 1-CPU system.

- Only a single plug-in PCIe VIC card may be installed on a 1-CPU system, and it must be installed in slots 1 or 2 of riser 1A or slot 1 of riser 1C.
- You can order an mLOM VIC card to be installed in the mLOM/OCP 3.0 slot internal to the chassis and thus have two VIC cards in operation at the same time. If you order a double-width GPU, it must be installed in slot 2; then a PCIe VIC can be installed in slot 1. See the [Table 12 on page 24](#) for the selection of plug-in and mLOM/OCP 3.0 VIC cards.
- For 2-CPU systems:
  - All the PCIe slots on riser 1, 2, and 3 are supported for the PCIe Cards.
  - You can order an mLOM VIC card to be installed in the mLOM slot internal to the chassis. You can also have up to two PCIe VICs.
    - If Riser 1A and 2A are selected, two PCIe VIC can be installed in slot 2 of Riser 1A and slot 5 of Riser 2A. If GPUs are installed in slot 2 of riser 1A or slot 5 of riser 2A, the NCSI capability automatically switches over to slot 1 of riser 1A or slot 4 of Riser 2A. Therefore, Cisco PCIe VICs can be installed in slot 1 of Riser 1A and slot 4 of Riser 2A if GPUs are installed in slots 2 of Riser 1A and slot 5 of Riser 2A.
    - If Riser 1C and 2C are selected, two PCIe VIC and be installed in slot 1 of Riser 1C and slot 4 of Riser 2C.
    - Maximum 1 PCIe VIC per riser

See [Table 13 on page 29](#) for the selection of plug-in and mLOM VIC cards.

- The server supports up to two PCIe Cisco VICs plus an MLOM VIC. However, single wire management is supported on only one VIC at a time. If multiple VICs are installed on a server, only one slot has NCSI enabled at a time and for single wire management, priority goes to the MLOM slot, then slot 2 of riser 1A/slot 1 of riser 1C, then slot 5 of riser 2A/slot 4 of riser 2C for NCSI management traffic. When multiple cards are installed, connect the single wire management cables in the priority order mentioned above.
- For installation in the mLOM slot, you can order either an mLOM VIC, or the OCP NIC - but not both. If ordering the OCP NIC, the OCP Mechanical Kit (UCSC-OCP3-KIT) must also be installed in order to mount OCP NIC in the mLOM slot.



#### NOTE:

- UCSM managed servers are discoverable only if a PCIe VIC is installed or a VIC is installed in the MLOM slot.
- Select Cisco UCS Virtual Interface Cards incorporate VIC Secure Boot technology to ensure the integrity of the VIC hardware and firmware upon server boot. VIC Secure Boot is independent of server-level secure boot from Cisco, but both technologies contribute to the Cisco trust model ensuring customers' equipment is genuine and running validated firmware.
- To help ensure that your operating system is compatible with the card you have selected, or to see additional cards that have been qualified to work with the UCS C240 M8 server, but are not sold on the Cisco price list, check the [Hardware Compatibility List](#) link.

## ORDER OPTIONAL PCIe OPTION CARD ACCESSORIES

- At the time of first launch, the 3rd Party Ethernet adapters were tested for interoperability with an initial selection of Optical Modules and Cables. Please check the Product Briefs for this initial list of

interoperable optics and cables at

<https://www.cisco.com/c/en/us/products/servers-unified-computing/third-party-adapters-listing.html>.

- For list of supported optics and cables for VIC 15428 and VIC 15238, refer to the VIC 15000 series data sheet at <https://www.cisco.com/c/en/us/products/collateral/interfaces-modules/unified-computing-system-adapters/ucs-vic-15000-series-ds.html>
- Cisco Transceiver Module Group (TMG) conducts tests with Cisco optics and cables and publishes the results in the TMG Compatibility Matrix. The latest compatibility with optical modules and DACs can be found at <https://tmgmatrix.cisco.com/>
- Refer to the these links for additional connectivity options.

<b>Intel:</b>
<a href="#">Product Guide</a>
<a href="#">Speed White Paper</a>

## STEP 10 ORDER GPU CARDS (OPTIONAL)

### Select GPU Options

The available GPU PCIe options and their riser slot compatibilities are listed in [Table 13](#).



#### CAUTION:

- 256GB DIMMs cannot be combined with GPU cards > 75W
- With GPU>75W installed, normal operating temperature is 28° C [82.4° F], lowered to 25° C [77° F], with a fan fault.
- When a GPU>75W is installed, CPUs with TDP greater than 330W are not supported.
- When H200-NVL or RTX Pro 6000 is installed, H200-NVL or RTX Pro 6000 GPUs are power-limited to 450W for efficiency and ambient temperature shall be limited to a maximum of 28° C.



#### NOTE:

- GPUs cannot be mixed
- All GPU cards must be procured from Cisco as there is a unique SBIOS ID required by CIMC and UCSM
- If a GPU with TDP equal or greater than 75W is ordered, 2 CPUs and all the 3 risers are required., and GPU airblocker will be installed in the middle slot of any empty riser in the system.
- If GPUs are installed in slot 2 of riser 1A or slot 5 of riser 2A, the NCSI capability automatically switches over to slot 1 of riser 1A or slot 4 of Riser 2A. Therefore, Cisco PCIe VICs can be installed in slots 1 and 4 on riser 1A and 2A, if GPUs are installed in slots 2 and 5. If you order multiple GPUs, they must be installed as shown in [Table 13 on page 29](#).
- If a double-wide (DW) GPU is selected in Riser 1 Slot 2, it blocks the use of Riser 1 Slot 3; similarly, if a DW GPU is selected in Riser 2 Slot 5, it blocks Riser 2 Slot 6, preventing simultaneous selection of these adjacent PCIe slots
- Refer to [Cisco UCS C240 M8 Installation Guide](#) for the more information

Table 13 Available PCIe GPU Cards

GPU Product ID (PID)	PID Description	Card Size	Max GPU Per Node	Riser Slot Compatibility			
				Riser 1A/1C	Riser 2A/2C	Riser 3A/3C <sup>1</sup>	Riser 1B/3B
UCSC-GPU-H200-NVL <sup>2</sup>	NVIDIA OEM H200-NVL GPU 600W, 141GB, 2-slot FHFL	double -wide	3	slot 2	slot 5	slot 7 (3C Only)	n/a

Table 13 Available PCIe GPU Cards

GPU Product ID (PID)	PID Description	Card Size	Max GPU Per Node	Riser Slot Compatibility			
UCSC-GPU-L40S	NVIDIA L40S: 350W, 48GB, 2-slot FHFL GPU	double-wide	3	slot 2	slot 5	slot 7 (3C Only)	n/a
UCSC-GPU-L4 <sup>3</sup>	NVIDIA L4:70W, 24GB, 1-slot HHHH GPU	Single-wide	8	All slots	All slots	slot 7 (3C Only)	n/a
UCSC-GPU-A16-D	NVIDIA A16 PCIE 250W 4X16GB	double-wide	3	slot 2	slot 5	slot 7 (3C Only)	n/a
UCSC-GPU-RTXP6000 <sup>2</sup>	NVIDIA RTX Pro 6000: 600W, 96GB, 2-Slot FHFL GPU	double-wide	3	slot 2	slot 5	slot 7 (3C Only)	n/a
<p><b>Accessories/spare included with GPU:</b></p> <ul style="list-style-type: none"> <li>■ When a GPU ready configuration is ordered, the server comes with low-profile heatsinks PID (UCSC-HSLP-C220M8), and special airblocker PID (UCSC-RISAB-24XM7) for GPUs.</li> <li>■ Air duct (UCSC-GPUAD-C240M8) is not auto-included with the double wide GPUs, however it is required selection under configuration. For GPU UCSC-GPU-L4 air duct is not required.</li> <li>■ UCS-P100CBL-240-D is included with the selection of A16 GPUs.</li> <li>■ CBL-G5GPU-C240M7 power cable included with the selection of L40S,H200-NV and RTXP6000.</li> </ul> <p><b>NOTE:</b> If you are adding GPUs later to a non-GPU ready configuration, you need to order the GPU kit (UCSC-GPUKIT-240M8=) along with the GPUs. You only need to order 1 GPU kit per server, regardless of the number of GPUs added. This GPU kit includes 2x low profile heatsinks, 1x GPU air duct, 2x thermal paste and 2x GPU air blockers. Please note that the GPU kit does not include risers, so you may need to order those separately.</p>							

Notes:

1. The server supports one full-height, full-length, double-wide GPU (PCIe slot 7 only) in Riser 3C.
2. H200-NVL or RTX Pro 6000 GPUs are power-limited to 450W for efficiency and ambient
3. L4 is supported on all slots in PCIe risers. The maximum would be 8 when you have riser 1A+2A+3A and populate all 8 slots with L4

## STEP 11 ORDER M.2 BOOT RAID CONTROLLER and SATA SSDs (OPTIONAL)

- Order Cisco boot optimized M.2 RAID controller from [Table 14](#). The boot optimized RAID controller plugs into a connector on the motherboard and holds up to two M.2 SATA drives.



### NOTE:

- The Cisco boot optimized M.2 RAID controller supports RAID 1 and JBOD mode
- The Cisco boot optimized M.2 RAID controller is available only with 240GB, 480GB, and 960GB M.2 SSDs
- CIMC is supported for configuring of volumes and monitoring of the controller and installed SATA M.2 drives
- The SATA M.2 drives can boot in UEFI mode only. Legacy boot mode is not supported
- Up to 1 Boot-Optimized RAID Controller is supported per system

Table 14 Boot-Optimized RAID Controller

Product ID (PID)	PID Description	M.2 Location	Hot- Swappable_M.2
UCS-M2-HWRAID2 <sup>1</sup>	Cisco Boot optimized M.2 Raid controller for SATA drives	Internal	No
UCSC-M2RM-M8 <sup>2</sup>	UCS C220/240 M8 Rear Hot-plug M.2 module (MLOM)	MLOM Slot	Yes
UCSC-M2RR-240M8	UCS C240 M8 Rear Hot-plug M.2 module (Riser 3)	By Riser 3	Yes

### Notes:

1. UCS-M2-HWRAID2 plugs into a connector on the motherboard and holds up to two M.2 SATA drives. Hot-plug replacement of the M.2 drives is not supported with UCS-M2-HWRAID2. The server must be powered off. UCSC-M2I-240M8 is auto included with UCS-M2-HWRAID2. If you are adding M.2 RAID controller as spare, you may need to order accessories with it.
2. UCSC-M2RM-M8 is installed in the mLOM location. If UCSC-M2RM-M8 is selected, mLOM/OCP card cannot be used. Hot-plug replacement of the M.2 drives is supported with UCSC-M2RM-M8. CBL-M2RM-240M8 is auto included with UCSC-M2RM-M8. If you are adding M.2 RAID controller as spare, you may need to order accessories with it.

- Order one or two matching M.2 SATA SSDs from [Table 15](#) along with a boot-optimized RAID controller (see [Table 14](#)). Each boot-optimized RAID controller can accommodate up to two SATA M.2 SSDs.



### NOTE:

- It is recommended that M.2 SATA SSDs be used as boot-only devices.
- Order one or two identical M.2 SATA SSDs for the boot optimized RAID controller
- You cannot mix M.2 SATA SSD capacities.

Table 15 M.2 SATA SSDs

Product ID (PID)	PID Description
UCS-M2-240G-D	240GB M.2 SATA Micron G2 SSD
UCS-M2-480G-D	480GB M.2 SATA SSD
UCS-M2-960G-D	960GB M.2 SATA Micron G2 SSD
UCS-M2240OA1V	240GB M.2 Boot Solidigm S4520 SATA 1X SSD
UCS-M2480OA1V	480GB M.2 Boot Solidigm S4520 SATA 1X SSD

## STEP 12 ORDER POWER SUPPLY (REQUIRED)

Power supplies share a common electrical and physical design that allows for hot-plug and tool-less installation into M8 C-series servers. Each power supply is certified for high-efficiency operation and offers multiple power output options. This allows users to “right-size” based on server configuration, which improves power efficiency, lowers overall energy costs and avoids stranded capacity in the data center.

Use the power calculator at the following link to determine the needed power based on the options chosen (CPUs, drives, memory, and so on):

<http://ucspowercalc.cisco.com>



### WARNING:

- Starting 1<sup>st</sup> January 2024, only Titanium rated PSUs are allowed to be shipped to European Union (EU), European Economic Area (EEA), United Kingdom (UK), Switzerland and other countries that adopted Lot 9 Regulation.
- DC PSUs are not impacted by Lot 9 Regulation and are EU/UK Lot 9 compliant

Table 16 Power Supply

Product ID (PID)	PID Description
PSU (Input High Line 210VAC)	
UCSC-PSU1-1200W-D	1200W Titanium power supply for C-Series Servers
UCSC-PSUV21050D-D	Cisco UCS 1050W -48V DC Power Supply for Rack Server
UCSC-PSU1-1600W-D	UCS 1600W AC PSU Platinum (Not EU/UK Lot 9 Compliant)
UCSC-PSU1-2300W-D	Cisco UCS 2300W AC Power Supply for Rack Servers Titanium
PSU (Input Low Line 110VAC)	
UCSC-PSU1-1200W-D	1200W Titanium power supply for C-Series Servers <b>Titanium</b>
UCSC-PSU1-2300W-D	2300W Power supply for C-series servers <b>Titanium</b>



### NOTE:

- In a server with two power supplies, both power supplies must be identical.
- Refer to *Power Specifications, page 53* section for the full details on the each power supply.

## STEP 13 SELECT INPUT POWER CORD(S) (REQUIRED)

Using [Table 17](#) and [Table 18](#), select the appropriate AC power cords. You can select a minimum of no power cords and a maximum of two. If you select the option R2XX-DMYMPWRCORD, no power cord is shipped with the server.



**NOTE:** [Table 17](#) lists the power cords for servers that use power supplies less than 2300 W. [Table 18](#) lists the power cords for servers that use 2300 W power supplies. Note that the power cords for 2300 W power supplies use a C19 connector so they only fit the 2300 W power supply connector.

Table 17 Available Power Cords (for server PSUs less than 2300 W)

Product ID (PID)	PID Description	Images
NO-POWER-CORD	ECO friendly green option, no power cable will be shipped	
CAB-48DC40A8AWG-D	C-Series -48VDC PSU Power Cord, 3.5M, 3 Wire, 8AWG, 40A	
CAB-N5K6A-NA	Power Cord, 200/240V 6A, North America	
CAB-AC-L620-C13-D	AC Power Cord, NEMA L6-20 - C13, 2M/6.5ft	
CAB-C13-CBN	CABASY,WIRE,JUMPER CORD, 27" L, C13/C14, 10A/250V	
CAB-C13-C14-2M	CABASY,WIRE,JUMPER CORD, PWR, 2 Meter, C13/C14,10A/250V	

Table 17 Available Power Cords (for server PSUs less than 2300 W)

Product ID (PID)	PID Description	Images
CAB-C13-C14-AC	CORD,PWR,JMP,IEC60320/C14,IEC60320/C13, 3.0M	
CAB-250V-10A-AR	Power Cord, 250V, 10A, Argentina	
CAB-9K10A-AU	Power Cord, 250VAC 10A 3112 Plug, Australia	
CAB-250V-10A-CN	AC Power Cord - 250V, 10A - PRC	
CAB-9K10A-EU	Power Cord, 250VAC 10A CEE 7/7 Plug, EU	
CAB-250V-10A-ID	Power Cord, 250V, 10A, India	
CAB-C13-C14-3M-IN	Power Cord Jumper, C13-C14 Connectors, 3 Meter Length, India	Image not available
CAB-C13-C14-IN	Power Cord Jumper,C13-C14 Connectors,1.4 Meter Length, India	Image not available
CAB-250V-10A-IS	Power Cord, SFS, 250V, 10A, Israel	

Table 17 Available Power Cords (for server PSUs less than 2300 W)

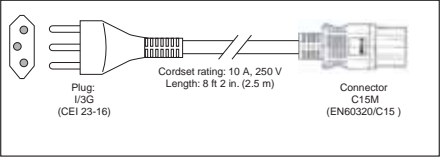
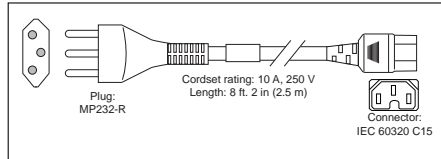
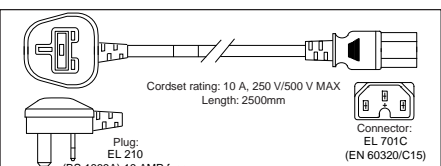
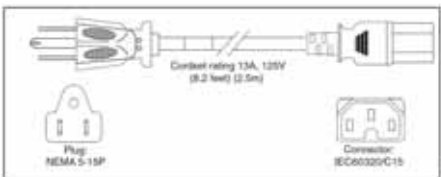
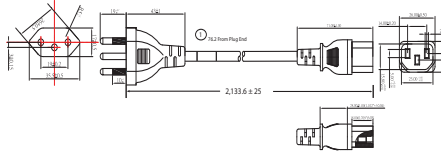
Product ID (PID)	PID Description	Images
CAB-9K10A-IT	Power Cord, 250VAC 10A CEI 23-16/VII Plug, Italy	
CAB-9K10A-SW	Power Cord, 250VAC 10A MP232 Plug, Switzerland	
CAB-9K10A-UK	Power Cord, 250VAC 10A BS1363 Plug (13 A fuse), UK	
CAB-9K12A-NA <sup>1</sup>	Power Cord, 125VAC 13A NEMA 5-15 Plug, North America	
CAB-250V-10A-BR	Power Cord - 250V, 10A - Brazil	
CAB-C13C142M-JP-D	Power Cord C13-C14, 2M/6.5ft Japan PSE mark	Image not available
CAB-9K10A-KOR <sup>1</sup>	Power Cord, 125VAC 13A KSC8305 Plug, Korea	Image not available
CAB-ACTW	AC Power Cord (Taiwan), C13, EL 302, 2.3M	Image not available
CAB-JPN-3PIN	Japan, 90-125VAC 12A NEMA 5-15 Plug, 2.4m	Image not available
CAB-48DC40A-INT-D	C-Series -48VDC PSU PWR Cord, 3.5M, 3 Wire, 8AWG, 40A (INT)	Image not available
CAB-48DC-40A-AS-D	C-Series -48VDC PSU PWR Cord, 3.5M, 3Wire, 8AWG, 40A (AS/NZ)	Image not available

Notes:

1. This power cord is rated to 125V and only supported for PSU rated at 1050W or less

Table 18 Available Power Cords (for servers with 2300 W PSUs)

Product ID (PID)	PID Description	Images
CAB-C19-CBN	Cabinet Jumper Power Cord, 250 VAC 16A, C20-C19 Connectors	Not applicable
CAB-S132-C19-ISRL	S132 to IEC-C19 14ft Israeli	Image not available
CAB-IR2073-C19-AR	IRSM 2073 to IEC-C19 14ft Argen	Image not available
CAB-BS1363-C19-UK	BS-1363 to IEC-C19 14ft UK	Image not available
CAB-SABS-C19-IND	SABS 164-1 to IEC-C19 India	Image not available
CAB-C2316-C19-IT	CEI 23-16 to IEC-C19 14ft Italy	Image not available
CAB-US515P-C19-US	NEMA 5-15 to IEC-C19 13ft US	Image not available
CAB-US520-C19-US	NEMA 5-20 to IEC-C19 14ft US	Image not available
CAB-US620P-C19-US	NEMA 6-20 to IEC-C19 13ft US	Image not available
CAB-9K16A-BRZ	Power Cord 250VAC 16A, Brazil, Src Plug EL224-C19	Image not available
CAB-9K16A-KOR	Power Cord 250VAC 16A, Korea, Src Plug	Image not available
CAB-AC-16A-AUS	Power Cord, 250VAC, 16A, Australia C19	Image not available
CAB-AC-2500W-EU	Power Cord, 250Vac 16A, Europe	Image not available
CAB-C14C19-10A-EU	Power Cord C14-C19 10A EU	Image not available
CAB-AC-2500W-INT	Power Cord, 250Vac 16A, INTL	Image not available
CAB-AC-2500W-ISRL	Power Cord,250VAC,16A,Israel	Image not available
CAB-AC-C19-TW	Power Cord, 250 V, 16A, C19, Taiwan	Image not available
CAB-AC-C6K-TWLK	Power Cord, 250Vac 16A, twist lock NEMA L6-20 plug, US	Image not available
CAB-AC16A-CH	16A AC Power Cord For China	Image not available
CAB-ACS-16	AC Power Cord (Swiss) 16A	Image not available
CAB-C19-C20-3M-JP	Power Cord C19-C20, 3M/10ft Japan PSE mark	Image not available
CAB-C19-C20-IND	Power Cord C19-C20 India	Image not available
NO-POWER-CORD	ECO friendly green option, no power cable will be shipped	Image not available

## STEP 14 ORDER TOOL-LESS RAIL KIT (REQUIRED) AND REVERSIBLE CABLE MANAGEMENT ARM (OPTIONAL)

### ■ Tool-less Rail Kit:

Select a tool-less rail kit (or no rail kit) from [Table 19](#).



#### NOTE:

- Cisco recommends a minimum quantity of 1 Rail Kit
- If you plan to rackmount your server, you must order a tool-less rail kit.

Table 19 Tool-less Rail Kit Options

Product ID (PID)	PID Description
UCSC-RAIL-D	Ball Bearing Rail Kit for M8 rack servers
UCSC-RAIL-NONE-D	No rail kit option

### ■ Optional Reversible Cable Management Arm:

The reversible cable management arm mounts on either the right or left slide rails at the rear of the server and is used for cable management. Select an Optional Reversible Cable Management Arm from [Table 20](#).



NOTE: If you plan to rackmount your server, you must order a tool-less rail kit. The same rail kits and CMAs are used for M6 and M7 servers.

Table 20 Cable Management Arm

Product ID (PID)	PID Description
UCSC-CMA-C240-D	Reversible CMA for M8 ball bearing rail kit

For more information about the tool-less rail kit and cable management arm, check the [Cisco UCS C240 M8 Installation Guide](#).

## STEP 15 SELECT MANAGEMENT CONFIGURATION (OPTIONAL)

By default, the server NIC mode is configured to be Shared LOM Extended. This NIC mode allows any LOM port or adapter card port to be used to access the Cisco Integrated Management Controller (CIMC). The Cisco VIC card must be installed in a slot with NCSI support.



### NOTE:

- There are no LOM ports on the C220 and C240 M8 servers. Servers ordered without a VIC or OCP card will ship in Dedicated network mode, unless otherwise specified by a configurable SW PID (**UCSC-CCARD-01**)
- For full details on all the NIC mode settings, see [Cisco UCS C240 M8 Installation Guide](#)

Table 21 Management Configuration Ordering Information

Product ID (PID)	PID Description
UCSC-DLOM-01-D	Dedicated Mode BIOS setting for C-Series Servers <ul style="list-style-type: none"> <li>■ To change the default NIC mode to Dedicated NIC mode, select this card.</li> <li>■ In Dedicated NIC mode, the CIMC can be accessed only through the dedicated management port.</li> <li>■ See <a href="#">Chassis Rear View, page 5</a> for the location of the management port</li> </ul>
UCSC-CCARD-01-D	Cisco Card Mode BIOS setting for C-Series Servers <ul style="list-style-type: none"> <li>■ To change the default NIC mode to Cisco Card Mode, select this card.</li> <li>■ If Cisco card selected, a VIC or MLOM must also be included in the configuration. if OCP card is included in the configuration, a VIC card must be selected.</li> <li>■ In this mode, you can assign an IP address to the CIMC using DHCP and from there you can fully automate your deployment.</li> </ul>

In addition, the optional software PIDs listed in [Table 24 on page 45](#) can be ordered for setting the server to operate in various modes.

## STEP 16 ORDER SECURITY DEVICES (REQUIRED)

A Trusted Platform Module (TPM) is a computer chip (microcontroller) that can securely store artifacts used to authenticate the platform (server). These artifacts can include passwords, certificates, or encryption keys. A TPM can also be used to store platform measurements that help ensure that the platform remains trustworthy. Authentication (ensuring that the platform can prove that it is what it claims to be) and attestation (a process helping to prove that a platform is trustworthy and has not been breached) are necessary steps to ensure safer computing in all environments.

A chassis intrusion switch gives a notification of any unauthorized mechanical access into the server.

The security device ordering information is listed in [Table 22](#)



**NOTE:**

- The TPM module used in this system conforms to TPM 2.0, as defined by the Trusted Computing Group (TCG). It is also SPI-based.
- TPM installation is supported after-factory. However, a TPM installs with a one-way screw and cannot be replaced, upgraded, or moved to another server. If a server with a TPM is returned, the replacement server must be ordered with a new TPM.

Table 22 Security Devices

Product ID (PID)	PID Description
UCS-TPM-002D-D	TPM 2.0 TCG FIPS140-2 CC+ Cert M7 Intel MSW2022 Compliant
UCSX-TPM-OPT-OUT-D	OPT OUT, TPM 2.0, TCG, FIPS140-2, CC EAL4+ Certified <sup>1</sup>
UCSC-INT-SW02-D	C220 and C240 M8 Chassis Intrusion Switch

**Notes:**

1. Please note that Microsoft certification requires a TPM 2.0 for bare-metal or guest VM deployments. Opt-out of the TPM 2.0 voids the Microsoft certification

## STEP 17 SELECT LOCKING SECURITY BEZEL (OPTIONAL)

An optional locking bezel can be mounted to the front of the chassis to prevent unauthorized access to the drives.

Select the locking bezel from [Table 23](#).

Table 23 Locking Bezel Option

Product ID (PID)	Description
UCSC-BZL-C240-D	C240 M8 Security Bezel

## STEP 18 SELECT OPERATING SYSTEM



**NOTE:**

- See this link for operating system guidance:  
<https://ucshcltool.cloudapps.cisco.com/public/>

Table 24 Operating System

Product ID (PID)	PID Description
<b>Microsoft Windows Server</b>	
MSWS-25-ST16C	Windows Server 2025 Standard (16 Cores)
MSWS-25-ST16C-NS	Windows Server 2025 Standard (16 Cores) - No Cisco SVC
MSWS-25-ST24C	Windows Server 2025 Standard (24 Cores)
MSWS-25-ST24C-NS	Windows Server 2025 Standard (24 Cores) - No SVC
MSWS-25-DC16C	Windows Server 2025 Datacenter (16 Core)
MSWS-25-DC16C-NS	Windows Server 2025 DC (16 Cores) - No SVC
MSWS-25-DC24C	Windows Server 2025 Datacenter (24 Core)
MSWS-25-DC24C-NS	Windows Server 2025 Datacenter (24 Core) - No SVC
<b>Red Hat</b>	
RHEL-2S2V-1A	Red Hat Enterprise Linux (1-2 CPU,1-2 VN); 1-Yr Support Req
RHEL-2S2V-3A	Red Hat Enterprise Linux (1-2 CPU,1-2 VN); 3-Yr Support Req
RHEL-2S2V-5A	Red Hat Enterprise Linux (1-2 CPU,1-2 VN); 5-Yr Support Req
RHEL-VDC-2SUV-1A	RHEL for Virt Datacenters (1-2 CPU, Unlim VN) 1 Yr Supp Req
RHEL-VDC-2SUV-3A	RHEL for Virt Datacenters (1-2 CPU, Unlim VN) 3 Yr Supp Req
RHEL-VDC-2SUV-5A	RHEL for Virt Datacenters (1-2 CPU, Unlim VN) 5 Yr Supp Req
<b>Red Hat Ent Linux/ High Avail/ Res Strg/ Scal</b>	
RHEL-2S2V-1S	Red Hat Enterprise Linux (1-2 CPU,1-2 VN); Prem 1Yr SnS Reqd
RHEL-2S2V-3S	Red Hat Enterprise Linux (1-2 CPU,1-2 VN); Prem 3Yr SnS Reqd
RHEL-2S-HA-1S	RHEL High Availability (1-2 CPU); Premium 1-yr SnS Reqd
RHEL-2S-HA-3S	RHEL High Availability (1-2 CPU); Premium 3-yr SnS Reqd
RHEL-2S-RS-1S	RHEL Resilent Storage (1-2 CPU); Premium 1-yr SnS Reqd
RHEL-2S-RS-3S	RHEL Resilent Storage (1-2 CPU); Premium 3-yr SnS Reqd
RHEL-VDC-2SUV-1S	RHEL for Virt Datacenters (1-2 CPU, Unlim VN) 1 Yr SnS Reqd

Table 24 Operating System (*continued*)

Product ID (PID)	PID Description
RHEL-VDC-2SUV-3S	RHEL for Virt Datacenters (1-2 CPU, Unlim VN) 3 Yr SnS Reqd
Red Hat SAP	
RHEL-SAP-2S2V-1S	RHEL for SAP Apps (1-2 CPU, 1-2 VN); Prem 1-Yr SnS Reqd
RHEL-SAP-2S2V-3S	RHEL for SAP Apps (1-2 CPU, 1-2 VN); Prem 3-Yr SnS Reqd
RHEL-SAPSP-3S	RHEL SAP Solutions Premium - 3 Years
RHEL-SAPSS-3S	RHEL SAP Solutions Standard - 3 Years
SUSE	
SLES-2S2V-1A	SUSE Linux Enterprise Svr (1-2 CPU,1-2 VM); 1-Yr Support Req
SLES-2S2V-3A	SUSE Linux Enterprise Svr (1-2 CPU,1-2 VM); 3-Yr Support Req
SLES-2S2V-5A	SUSE Linux Enterprise Svr (1-2 CPU,1-2 VM); 5-Yr Support Req
SLES-2S-LP-1A	SUSE Linux Live Patching Add-on (1-2 CPU); 1yr Support Req
SLES-2S-LP-3A	SUSE Linux Live Patching Add-on (1-2 CPU); 3yr Support Req
SLES-2SUVM-1A	SUSE Linux Enterprise Svr (1-2 CPU,Unl VM) LP; 1Y Supp Req
SLES-2SUVM-3A	SUSE Linux Enterprise Svr (1-2 CPU,Unl VM) LP; 3Y Supp Req
SLES-2SUVM-5A	SUSE Linux Enterprise Svr (1-2 CPU,Unl VM) LP; 5Y Supp Req
SLES-2S2V-1S	SUSE Linux Enterprise Svr (1-2 CPU,1-2 VM); Prio 1-Yr SnS
SLES-2S2V-3S	SUSE Linux Enterprise Svr (1-2 CPU,1-2 VM); Prio 3-Yr SnS
SLES-2S2V-5S	SUSE Linux Enterprise Svr (1-2 CPU,1-2 VM); Prio 5-Yr SnS
SLES-2S-HA-1S	SUSE Linux High Availability Ext (1-2 CPU); 1yr SnS
SLES-2S-HA-3S	SUSE Linux High Availability Ext (1-2 CPU); 3yr SnS
SLES-2S-HA-5S	SUSE Linux High Availability Ext (1-2 CPU); 5yr SnS
SLES-2S-GC-1S	SUSE Linux GEO Clustering for HA (1-2 CPU); 1yr Sns
SLES-2S-GC-3S	SUSE Linux GEO Clustering for HA (1-2 CPU); 3yr SnS
SLES-2S-GC-5S	SUSE Linux GEO Clustering for HA (1-2 CPU); 5yr SnS
SLES-2S-LP-1S	SUSE Linux Live Patching Add-on (1-2 CPU); 1yr SnS Required
SLES-2S-LP-3S	SUSE Linux Live Patching Add-on (1-2 CPU); 3yr SnS Required
SLES-2SUVM-1S	SUSE Linux Enterprise Svr (1-2 CPU,Unl VM) LP; Prio 1Y SnS
SLES-2SUVM-3S	SUSE Linux Enterprise Svr (1-2 CPU,Unl VM) LP; Prio 3Y SnS
SLES-2SUVM-5S	SUSE Linux Enterprise Svr (1-2 CPU,Unl VM) LP; Prio 5Y SnS

Table 24 Operating System (*continued*)

Product ID (PID)	PID Description
SLES and SAP	
SLES-SAP-2S2V-1S	SLES for SAP Apps (1-2 CPU, 1-2 VM); Priority 1-Yr SnS
SLES-SAP-2S2V-3S	SLES for SAP Apps (1-2 CPU, 1-2 VM); Priority 3-Yr SnS
SLES-SAP-2S2V-5S	SLES for SAP Apps (1-2 CPU, 1-2 VM); Priority 5-Yr SnS
SLES-SAP-2S2V-1A	SLES for SAP Apps w/ HA (1-2 CPU, 1-2 VM); 1-Yr Support Reqd
SLES-SAP-2S2V-3A	SLES for SAP Apps w/ HA (1-2 CPU, 1-2 VM); 3-Yr Support Reqd
SLES-SAP-2S2V-5A	SLES for SAP Apps w/ HA (1-2 CPU, 1-2 VM); 5-Yr Support Reqd

## STEP 19 CISCO INTERSIGHT

Cisco Intersight™ is a Software-as-a-Service (SaaS) hybrid cloud operations platform which delivers intelligent automation, observability, and optimization to customers for traditional and cloud-native applications and infrastructure.

Product ID (PID)	
DC-MGT-SAAS	Cisco Intersight SaaS

Select Cisco Intersight subscription option as desired from [Table 25](#)

Table 25 Cisco Intersight

Product ID (PID)	PID Description
<b>Cisco Intersight 2.0 Infrastructure Services</b>	
DC-MGT-IS-SAAS-ES <sup>1</sup>	Infrastructure Services SaaS/CVA - Essentials
DC-MGT-IS-SAAS-AD <sup>1</sup>	Infrastructure Services SaaS/CVA - Advantage
DC-MGT-IS-PVAPP-ES <sup>1</sup>	Infrastructure Services PVA - Essentials
DC-MGT-IS-PVAPP-AD <sup>1</sup>	Infrastructure Services PVA - Advantage
<b>Add-Ons</b>	
DC-MGT-IS-UCSD	UCS Director - 1 Server License (includes Network, Storage)
<b>Cisco Intersight Workload Optimizer (IWO) - SaaS</b>	
<b>VM Instance</b>	
DC-MGT-WO-SAAS-ES <sup>1</sup>	Cisco Intersight Workload Optimizer SaaS - Essentials
DC-MGT-WO-SAAS-AD <sup>1</sup>	Cisco Intersight Workload Optimizer SaaS - Advantage
DC-MGT-WO-SAAS-PR <sup>1</sup>	Cisco Intersight Workload Optimizer SaaS - Premier
<b>VDI Instance</b>	
DC-MGT-WOD-SAAS-ES <sup>1</sup>	Cisco Intersight Workload Optimizer SaaS VDI - Essentials
DC-MGT-WOD-SAAS-AD <sup>1</sup>	Cisco Intersight Workload Optimizer SaaS VDI - Advantage
DC-MGT-WOD-SAAS-PR <sup>1</sup>	Cisco Intersight Workload Optimizer SaaS VDI - Premier

**Notes:**

1. Smart account (SA) required

Select Cisco Intersight support option as desired from [Table 26](#)

---

Table 26 Cisco Intersight Support

Product ID (PID)	PID Description
Cisco Intersight Support	
SVS-SSTCS-DCMGMT <sup>1</sup>	Solution Support for DC Mgmt
SVS-L1DCS-INTER <sup>1</sup>	CXL1 for INTERSIGHT
SVS-L2DCS-INTER <sup>1</sup>	CXL2 for INTERSIGHT
SVS-DCM-SUPT-BAS	Basic Support for DCM

Notes:

1. Smart account (SA) required



**NOTE:** An Intersight license is required for every server.

---

# SUPPLEMENTAL MATERIAL

## PCIe Port Assignment

- With Gen5 x2 each drive

Slots	CPU1	CPU2
Riser 1A	Slot 1: Gen5 x8 Slot 2: Gen5 x16 Slot 3: Gen5 x8	
Riser 1C	Slot 1: Gen5 x16 Slot 2: Gen5 x16	
Riser 1D	Gen5 x4 each drive	
Riser 2A		Slot 4: Gen5 x8 Slot 5: Gen5 x16 Slot 6: Gen5 x8
Riser 2C		Slot 4: Gen5 x16 Slot 5: Gen5 x16
Riser 3A		Slot 7: Gen5 x8 Slot 8: Gen5 x8
Riser 3C		Slot 7: Gen5 x16
Riser 3D		Gen5 x4 each drive
mLOM / OCP	Gen4 x16	
E3.S NVMe slots 1-16		Gen5 x2 each
E3.S NVMe slots 17-32	Gen5 x2 each	
M.2 Boot RAID	Gen3 x2	

- With Gen5 x4 each drive



**NOTE:**

- In x4 config, Riser 1D and 3D are only supported with less than 16 front drives
- In x4 config, Riser 2E is required for more than 16 front drives
- In x4 config, Riser 1E and 2E are required for more than 24 front drive

Slots	CPU1	CPU2
Riser 1A	Slot 1: Gen5 x8 Slot 2: Gen5 x16 Slot 3: Gen5 x8	
Riser 1C	Slot 1: Gen5 x16 Slot 2: Gen5 x16	
Riser 1D	Gen5 x4 each drive	
Riser 1E	2x MCIO Gen5 x16 for retimers to support E3.S slots 25-32	
Riser 2A		Slot 4: Gen5 x8 Slot 5: Gen5 x16 Slot 6: Gen5 x8
Riser 2C		Slot 4: Gen5 x16 Slot 5: Gen5 x16
Riser 2E		2x MCIO Gen5 x16 for retimers to support E3.S slots 1-8
Riser 3A		Slot 7: Gen5 x8 Slot 8: Gen5 x8
Riser 3C		Slot 7: Gen5 x16
Riser 3D		Gen5 x4 each drive
mLOM / OCP	Gen4 x16	
E3.S NVMe slots 1-8		Gen5 x4 each
E3.S NVMe slots 9-16		Gen5 x4 each
E3.S NVMe slots 17-24	Gen5 x4 each	
E3.S NVMe slots 25-32	Gen5 x4 each	
M.2 Boot RAID	Gen3 x2	

## Serial Port Details

Figure 5 Serial Port (Female RJ-45 Connector) Pinout  
Serial Port (RJ-45 Female Connector)

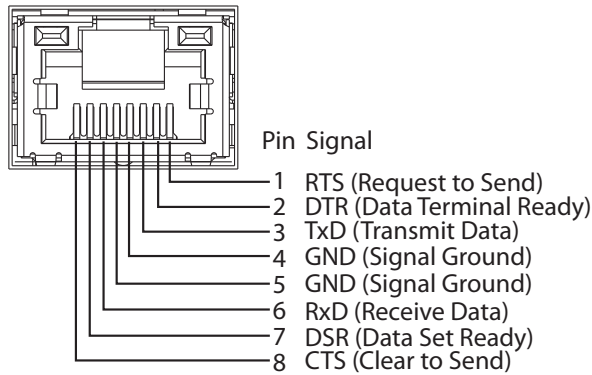

## KVM Cable

The KVM cable provides a connection into the server, providing a DB9 serial connector, a VGA connector for a monitor, and dual USB ports for a keyboard and mouse. With this cable, you can create a direct connection to the operating system and the BIOS running on the server.

Table 27 KVM Cable

Product ID (PID)	PID Description
N20-BKVM	KVM cable for UCS Server console port

Figure 6 KVM Cable

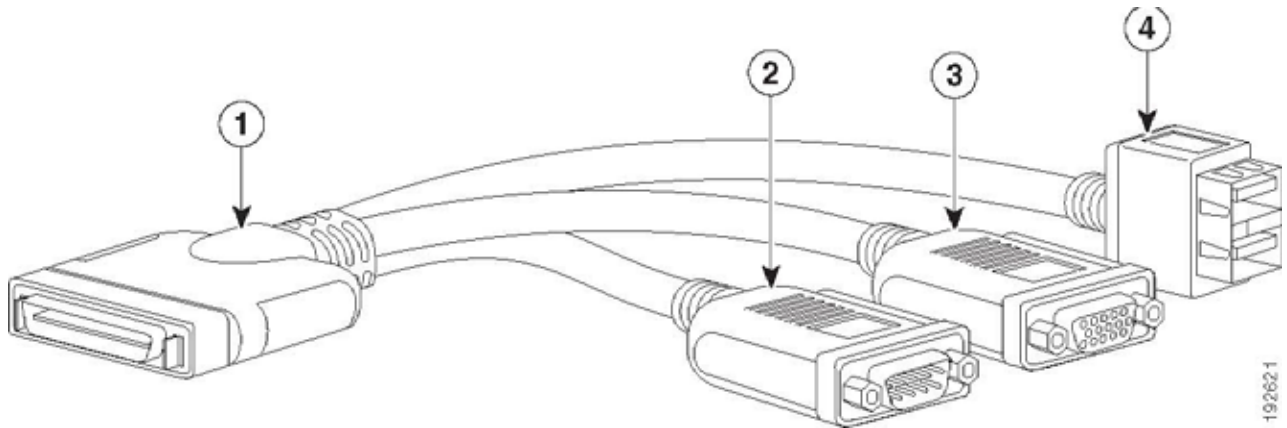

1	Connector (to server front panel)	3	VGA connector (for a monitor)
2	DB-9 serial connector	4	Two-port USB connector (for a mouse and keyboard)

## SPARE PARTS

This section lists the upgrade and service-related parts for the UCS C240 M8 server. Some of these parts are configured with every server.

- Spare parts for the Cisco UCS C240 M8 server use the same Product IDs (PIDs) as the regular components, with the addition of an equals sign (=) at the end of the PID. For example, if the regular PID for a component is UCS-CPU-I6760P, its corresponding spare PID would be UCS-CPU-I6760P=
- Therefore, to find the full list of available spare parts and their descriptions, refer to the relevant sections for each component (e.g., Risers, CPUs, Memory, Drive Controllers, Drives, PCIe Cards, Power Supplies, etc.) and append an = to the listed PIDs.



**NOTE:** Some spare parts you order may also require accessories for full functionality. For example, drives or RAID controllers may need accompanying cables. CPUs may need heatsinks, thermal paste, and installation tools. The spares and their accessory parts are listed in [Table 28](#).

However, the [Table 28](#) below lists the spare parts and their descriptions. These are different from the main components described in previous sections. This table is the complete list for all spare part IDs (they end with an '=' sign), as these specific spare parts are not listed individually in those earlier sections.

Table 28 Spare Parts

Product ID (PID)	PID Description
UCSC-HSHP-C240M8=	Heatsink for C240M8 w/o GPU
UCSC-HSLP-C220M8=	Heatsink for C220M8, C240M8L and C240M8 w/GPU
UCS-DDR5-BLK=	UCS DDR5 DIMM Blanks
UCSC-FBRS2-C240-D=	C240 M7 2U Riser2 Filler Blank
UCSC-FBRS3-C245=	C245 M8 2U Riser3 Filler Blank, Non-Perforated
UCSC-E3S1T-F=	UCS C-Series E3.S 1T Drive Filler
UCSC-RIS1E-240M8=	UCS C240 M8 Riser 1E support E3.S drive for Gen5x4
UCSC-RIS2E-240M8=	UCS C240 M8 Riser 2E support E3.S drive for Gen5x4 (CPU2)
UCSC-PSU-BLK-D=	Power Supply Blanking Panel for M7 / M8 servers
CBL-M2RM-240M8=	C240M8 rear Hot-plug M.2 (MLOM/OCP) cable
CBL-E3SX2-2UM8-P1=	C240M8 Y cable MB P1 to E3.S BP (x2)
CBL-E3SX2-2UM8-P2=	C240M8 Y cable MB P2 to E3.S BP (x2)
CBL-E3SX2-2UM8-P3=	C240M8 Y cable MB P3 to E3.S BP (x2)+F23:F27
CBL-E3SX2-2UM8-P4=	C240M8 Y cable MB P4 to E3.S BP (x2)
CBL-E3SX4-2UM8-P1=	C240M8 Y cable MB P1 to E3.S BP (x4) 21-24
CBL-E3SX4-2UM8-P2=	C240M8 Y cable MB P2 to E3.S BP (x4) 17-20
CBL-E3SX4-2UM8-P3=	C240M8 Y cable MB P3 to E3.S BP (x4) 13-16
CBL-E3SX4-2UM8-P4=	C240M8 Y cable MB P4 to E3.S BP (x4) 9-12
CBL-RIS1E-240M8=	C240M8 X cable Riser1E to E3.S BP 25-28 & 29-32

Table 28 Spare Parts

Product ID (PID)	PID Description
CBL-RIS2E-240M8=	C240M8 X cable Riser2E to E3.S BP 1-4 & 5-8
UCSC-RISAB-24XM7=	UCS C-Series M7 2U Air Blocker GPU only
UCSC-M2I-240M8=	UCS C240 M8 Internal M.2 module
UCS-P100CBL-240-D=	C240 NVIDIA P100 / A100 / A40 / A16 / A30 Cable
UCS-M10CBL-C240M7=	C240 GPU Power Cable for the UCSC-GPU-FLEX170
CBL-G5GPU-C240M7=	C240M7 PCIe CEM compliant 12VHPWR power cable(upto 450W)
UCSC-OCP3-KIT-D=	C2XX OCP 3.0 Interposer W/Mech Assy
UCSC-MBF3CBL-MX2U=	Cisco-UCSC M7/8 2U Power Cable for Nvidia BlueField-3 DPU
UCSC-FAN-C240M8=	UCS C240M8 Fan

# TECHNICAL SPECIFICATIONS

## Dimensions and Weight

Table 29 Dimensions and Weight

Parameter	Value
Height	3.42 in. (8.7 cm)
Width (including slam latches)	16.9 in. (42.9 cm)
Depth	30 in. (76.2 cm)
Weight	
0*E3.S HDDs, 0*CPU(w/o HS), 0*DIMM, 1*2300W PSU, mLOM, riser cage 1(w/o PCIe), riser cage 2(w/o PCIe), riser cage 3(w/o PCIe)	19.82 kg = 43.69 lb
0*E3.S HDDs, 0*CPU(w/o HS), 0*DIMM, 1*2300W PSU, mLOM, riser cage 1(w/o PCIe), riser cage 2(w/o PCIe), riser cage 3(w/o PCIe), Rail kit	23.58 kg = 51.99 lb
1*E3.S HDDs, 1*CPU(w/HS), 1*DIMM, 1*2300W PSU, mLOM, riser cage 1(w/o PCIe), riser cage 2(w/o PCIe), riser cage 3(w/o PCIe)	20.50 kg = 45.19 lb
1*E3.S HDDs, 1*CPU(w/HS), 1*DIMM, 1*2300W PSU, mLOM, riser cage 1(w/o PCIe), riser cage 2(w/o PCIe), riser cage 3(w/o PCIe), Rail kit	24.26 kg = 53.48 lb
32*E3.S HDDs, 2*CPU(w/HS), 32*DIMM, 2*2300W PSU, mLOM, riser cage 1(w/o PCIe), riser cage 2(w/o PCIe), riser cage 3(w/o PCIe)	26.47 kg = 58.36 lb
32*E3.S HDDs, 2*CPU(w/HS), 32*DIMM, 2*2300W PSU, mLOM, riser cage 1(w/o PCIe), riser cage 2(w/o PCIe), riser cage 3(w/o PCIe), Rail kit	30.23 kg = 66.65 lb

## Power Specifications

The server is available with the following types of power supplies:

- 1050W (DC) power supply (see [Table 30](#))
- 1200 W (AC) power supply (see [Table 31](#))
- 1600 W (AC) power supply (see [Table 32](#))
- 2300 W (AC) power supply (see [Table 33](#))

**Table 30 1050W (DC) Power Supply Specifications**

Parameter	Specification
Input Connector	Molex 42820
Input Voltage Range (V rms)	-48
Maximum Allowable Input Voltage Range (V rms)	-40 to -72
Frequency Range (Hz)	NA
Maximum Allowable Frequency Range (Hz)	NA
Maximum Rated Output (W)	1050
Maximum Rated Standby Output (W)	36
Nominal Input Voltage (V rms)	-48
Nominal Input Current (A rms)	24
Maximum Input at Nominal Input Voltage (W)	1154
Maximum Input at Nominal Input Voltage (VA)	1154
Minimum Rated Efficiency (%) <sup>1</sup>	91
Minimum Rated Power Factor <sup>1</sup>	NA
Maximum Inrush Current (A peak)	15
Maximum Inrush Current (ms)	0.2
Minimum Ride-Through Time (ms) <sup>2</sup>	5

**Notes:**

1. This is the minimum rating required to achieve 80 PLUS Platinum certification, see test reports published at <http://www.80plus.org/> for certified values
2. Time output voltage remains within regulation limits at 100% load, during input voltage dropout

Table 31 1200 W (AC) Power Supply Specifications

Parameter	Specification			
Input Connector	IEC320 C14			
Input Voltage Range (Vrms)	100 to 240			
Maximum Allowable Input Voltage Range (Vrms)	90 to 264			
Frequency Range (Hz)	50 to 60			
Maximum Allowable Frequency Range (Hz)	47 to 63			
Maximum Rated Output (W) <sup>1</sup>	1100	1200		
Maximum Rated Standby Output (W)	48			
Nominal Input Voltage (Vrms)	100	120	208	230
Nominal Input Current (Arms)	12.97	10.62	6.47	5.84
Maximum Input at Nominal Input Voltage (W)	1300	1264	1343	1340
Maximum Input at Nominal Input Voltage (VA)	1300	1266	1345	1342
Minimum Rated Efficiency (%) <sup>2</sup>	90	90	91	91
Minimum Rated Power Factor <sup>2</sup>	0.97	0.97	0.97	0.97
Maximum Inrush Current (A peak)	20			
Maximum Inrush Current (ms)	0.2			
Minimum Ride-Through Time (ms) <sup>3</sup>	12			

Notes:

1. Maximum rated output is limited to 1100W when operating at low-line input voltage (100-127V)
2. This is the minimum rating required to achieve 80 PLUS Titanium certification, see test reports published at <http://www.80plus.org/> for certified values
3. Time output voltage remains within regulation limits at 100% load, during input voltage dropout

Table 32 1600 W (AC) Power Supply Specifications

Parameter	Specification			
Input Connector	IEC320 C14			
Input Voltage Range (V rms)	200 to 240			
Maximum Allowable Input Voltage Range (V rms)	180 to 264			
Frequency Range (Hz)	50 to 60			
Maximum Allowable Frequency Range (Hz)	47 to 63			
Maximum Rated Output (W)	1600			
Maximum Rated Standby Output (W)	36			
Nominal Input Voltage (V rms)	100	120	208	230
Nominal Input Current (A rms)	NA	NA	8.8	7.9
Maximum Input at Nominal Input Voltage (W)	NA	NA	1778	1758
Maximum Input at Nominal Input Voltage (VA)	NA	NA	1833	1813
Minimum Rated Efficiency (%) <sup>1</sup>	NA	NA	90	91
Minimum Rated Power Factor <sup>2</sup>	NA	NA	0.97	0.97
Maximum Inrush Current (A peak)	30			
Maximum Inrush Current (ms)	0.2			
Minimum Ride-Through Time (ms) <sup>2</sup>	12			

Notes:

1. This is the minimum rating required to achieve 80 PLUS Platinum certification, see test reports published at <http://www.80plus.org/> for certified values
2. Time output voltage remains within regulation limits at 100% load, during input voltage dropout

Table 33 2300 W (AC) Power Supply Specifications

Parameter	Specification			
Input Connector	IEC320 C20			
Input Voltage Range (Vrms)	100 to 240			
Maximum Allowable Input Voltage Range (Vrms)	90 to 264			
Frequency Range (Hz)	50 to 60			
Maximum Allowable Frequency Range (Hz)	47 to 63			
Maximum Rated Output (W) <sup>1</sup>	2300			
Maximum Rated Standby Output (W)	36			
Nominal Input Voltage (Vrms)	100	120	208	230
Nominal Input Current (Arms)	13	11	12	10.8
Maximum Input at Nominal Input Voltage (W)	1338	1330	2490	2480
Maximum Input at Nominal Input Voltage (VA)	1351	1343	2515	2505
Minimum Rated Efficiency (%) <sup>2</sup>	92	92	93	93
Minimum Rated Power Factor <sup>2</sup>	0.99	0.99	0.97	0.97
Maximum Inrush Current (A peak)	30			
Maximum Inrush Current (ms)	0.2			
Minimum Ride-Through Time (ms) <sup>3</sup>	12			

Notes:

1. Maximum rated output is limited to 1200W when operating at low-line input voltage (100-127V)
2. This is the minimum rating required to achieve 80 PLUS Titanium certification, see test reports published at <http://www.80plus.org/> for certified values
3. Time output voltage remains within regulation limits at 100% load, during input voltage dropout



**NOTE:** For configuration-specific power specifications, use the Cisco UCS Power Calculator at this URL: <http://ucspowercalc.cisco.com>

## Environmental Specifications

The environmental specifications for the server are listed in [Table 34](#).

Table 34 Environmental Specifications

Parameter	Minimum
Operating Temperature	5 °C to 35 °C (supports ASHRAE Class A4 and/or Class A3 and/or Class A2) ASHRAE Class A3 will be generic test profile unless otherwise specified by product engineering. System shall continue to operate with a single fan failure (one failed impeller in dual impeller housings) across the ASHRAE recommended operating range of 18 °C to 27 °C. While undesired, increased power consumption and/or acoustic noise is permitted during a fan fail event.
Non-Operating Temperature	Dry bulb temperature of -40 °C to 65 °C (-40 °F to 149 °F)
Operating Relative Humidity	8% to 90% relative humidity, non-condensing, with maximum wet bulb 28 °C (82.4 °F) within operational temperature range of 5 °C to 50 °C (41 °F to 122 °F)
Non-Operating Relative Humidity	5% to 93% relative humidity, non-condensing, with a maximum wet bulb temperature of 28 °C across the 20 °C to 40 °C dry bulb range.
Maximum Operating Duration	Unlimited
Operating Altitude	A maximum elevation of 3050 meters (10,006 ft)
Non-Operating Altitude	An elevation of 0 to 12,000 meters (39,370 ft)
Sound Power level, Measure A-weighted per ISO7779 LWAd (Bels) Operation at 23 °C (73 °F)	1RU: 5.5B 2RU: 5.8B Racked product: 6.8B
Sound Pressure level, Measure A-weighted per ISO7779 LpAm (dBA) Operation at 23 °C (73 °F)	1RU: 40dB 2RU: 43dB Racked product: 55dB

## Extended Operating Temperature Hardware Configuration Limits

Table 35 Cisco UCS C240 M8 Extended Operating Temperature Hardware Configuration Limits

Platform <sup>1</sup>	ASHRAE A3 (5°C to 40°C) <sup>2</sup>	ASHRAE A4 (5°C to 45°C) <sup>3</sup>
Processor	<=350W	<=250W (up to 350W supported with Riser 2 only)
DIMMs	<= 128GB	<= 128GB
GPU	Not Supported	Not Supported
PCIe	PCIe Gen 4 devices only	PCIe Gen 4 devices only
Front Storage	SAS/SATA/NVMe (NVMe SSD up to 1.9TB)	SAS/SATA/NVMe (NVMe SSD up to 1.9TB)
Rear Storage	Not Supported	Not Supported
M.2	SATA M.2 Supported	SATA M.2 Supported
PSUs	2x2300W PSUs required in redundant mode	2x2300W PSUs required in redundant mode
MLOM / OCP	4x25G MLOM only. No OCP support	4x25G MLOM only. No OCP support

Notes:

1. Two PSUs are required and PSU failure is not supported
2. Non-Cisco UCS qualified peripherals and/or peripherals that consume more than 25W are not supported
3. High power or maximum power fan control policy must be applied.

## Compliance Requirements

The regulatory compliance requirements for C-Series servers are listed in [Table 36](#).

**Table 36 UCS C-Series Regulatory Compliance Requirements**

Parameter	Description
Regulatory Compliance	Products should comply with CE Markings per directives 2014/30/EU and 2014/35/EU
Safety	UL 60950-1/62368-1 CAN/CSA-C22.2 No. 60950-1/62368-1 IEC/EN 60950-1/62368-1 AS/NZS 62368.1 GB 4943.1-2022 CNS 15598-1:2020
EMC - Emissions	47CFR Part 15 (CFR 47) Class A AS/NZS CISPR32 Class A CISPR32 Class A EN55032 Class A ICES003 Class A VCCI-CISPR32 Class A EN61000-3-2 EN61000-3-3 KS C 9832 Class A EN 300386 Class A
EMC - Immunity	EN55035 EN55024 CISPR24/35 EN300386 KS C 9835 IEC/EN61000-6-1

## DISCONTINUED EOL PRODUCTS

Below is the list of parts were previously available for this product and are no longer sold. Please refer to the EOL Bulletin Links via table below to determine if still supported.

Table 37 EOS

Product ID	Description	EOL/EOS link
UCSB-CABL-C19-BRZ	NBR 14136 to C19 AC 14FT POWER CORD, BRAZIL	<a href="https://www.cisco.com/c/en/us/products/collateral/servers-unified-computing/ucs-c-series-rack-servers/select-ucs-accessories-eol15715.html">https://www.cisco.com/c/en/us/products/collateral/servers-unified-computing/ucs-c-series-rack-servers/select-ucs-accessories-eol15715.html</a>



**Americas Headquarters**  
Cisco Systems, Inc.  
San Jose, CA

**Asia Pacific Headquarters**  
Cisco Systems (USA) Pte. Ltd.  
Singapore

**Europe Headquarters**  
Cisco Systems International BV Amsterdam,  
The Netherlands

Cisco has more than 200 offices worldwide. Addresses, phone numbers, and fax numbers are listed on the Cisco Website at [www.cisco.com/go/offices](http://www.cisco.com/go/offices).

Cisco and the Cisco Logo are trademarks of Cisco Systems, Inc. and/or its affiliates in the U.S. and other countries. A listing of Cisco's trademarks can be found at [www.cisco.com/go/trademarks](http://www.cisco.com/go/trademarks). Third party trademarks mentioned are the property of their respective owners. The use of the word partner does not imply a partnership relationship between Cisco and any other company. (01/05)