This Product has been discontinued



Spec Sheet

Cisco UCS B460 M4
Blade Server
(with Intel® Xeon® E7 v4
CPU)

CISCO SYSTEMS
170 WEST TASMAN DR.
SAN JOSE, CA, 95134
WWW.CISCO.COM

PUBLICATION HISTORY

REV A.6 MAY 21, 2019

CONTENTS

OVERVIEW	3
DETAILED VIEWS	4
Chassis Front View	4
BASE SERVER STANDARD CAPABILITIES and FEATURES	5
CONFIGURING the SERVER	7
STEP 1 VERIFY BASE SKU	8
STEP 2 CHOOSE CPU(S)	10
STEP 3 CHOOSE MEMORY	12
STEP 4 CHOOSE SOLID-STATE DRIVES (SSDs)	18
STEP 5 CHOOSE RAID CONFIGURATION	19
STEP 6 CHOOSE ADAPTERS	20
STEP 7 ORDER A TRUSTED PLATFORM MODULE (OPTIONAL)	25
STEP 8 ORDER CISCO FLEXIBLE FLASH SECURE DIGITAL CARDS	26
STEP 9 ORDER OPTIONAL INTERNAL USB 2.0 DRIVE	27
STEP 10 ORDER OPTIONAL KVM CABLE	28
STEP 11 CHOOSE OPERATING SYSTEM AND VALUE-ADDED SOFTWARE	29
STEP 12 CHOOSE OPERATING SYSTEM MEDIA KIT	32
STEP 13 CHOOSE SERVICE and SUPPORT LEVEL	33
SUPPLEMENTAL MATERIAL	38
Motherboard	38
DIMM and CPU Layout	40
Memory Population Recommendations	41
Memory Mixing Guidelines	42
Upgrade and Servicing-Related Parts	43
Drive and Blade Server Blanking Panels	43
Replacing a CPU (with CPU heat sink)	43
CPU Removal and Installation (“pick n place”) Tool Set	43
Thermal Grease (with syringe applicator) for CPU to Heatsink Seal	44
CPU Heat Sink Cleaning Kit	44
Network Connectivity	45
VIC 1340 and Port Expander	47
Connectivity Using the Cisco UCS 2304/2208XP/2204XP Fabric Extender	48
TECHNICAL SPECIFICATIONS	54
Dimensions and Weight	54
Power Specifications	54
Discontinued EOL Products	55

OVERVIEW

The Cisco® UCS B460 M4 E7 v4 High-Performance Blade Server (*Figure 1*) is a four-socket, full-width double-high blade server supporting the Intel® Xeon® E7-4800 v4 and E7-8800 v4 series processor family CPUs, with up to 6 TB of double-data-rate 4 (DDR4) memory in 96 slots, up to 4 7 mm high small form factor (SFF), hot-swappable ¹ drive bays for solid state drives (SSDs), four dual-port and two quad-port mezzanine card connections for up to 320 Gbps aggregate I/O bandwidth. The Cisco UCS B460 M4 E7 v4 server is designed to power the most demanding enterprise applications.

As shown in *Figure 1*, the B460 M4 E7 v4 server consists of two Scalable M4 Blade Modules and a Scalability Connector that cross-connects the two Blade Modules and allows them to function as a single server. The Blade Module on the bottom is the “Master” and the Blade Module on the top is the “Slave.”

The server is controlled with UCS Manager (UCSM) version 2.2(8).

Figure 1 Cisco UCS B460 M4 E7 v4 Blade Server

Front View



NOTE: The Scalability Connector for the UCS B460 M4 E7 v4 is of Cisco Metallic Grey color (the Scalability Connector for the UCS B460 M4 E7 v2 or E7 v3 server is of Cisco Dark Grey color).

Notes . . .

1. Hot-swap replacement means that you do not have to precondition or shut down the component in software before you remove it.

DETAILED VIEWS

Chassis Front View

Figure 2 shows the front of the Cisco UCS B460 M4 E7 v4 Blade Server.

Figure 2 Chassis Front View

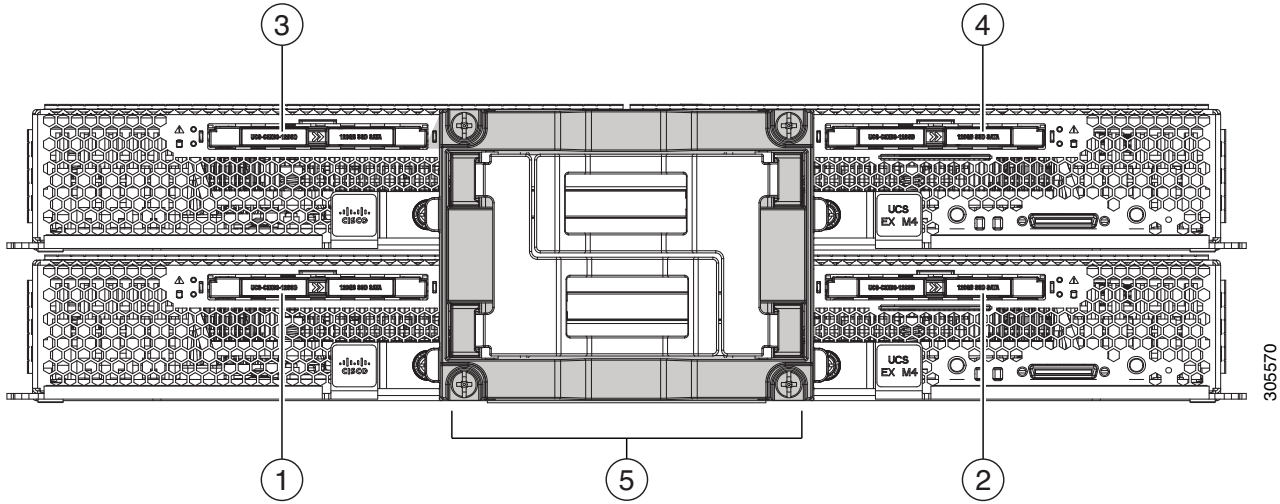

1	Drive bay 1	4	Drive bay 4
2	Drive bay 2	5	UCS Scalability Connector
3	Drive bay 3		

BASE SERVER STANDARD CAPABILITIES and FEATURES

Table 1 lists the capabilities and features of the base server. Details about how to configure the server for a particular feature or capability (for example, number of processors, disk drives, or amount of memory) are provided in *CONFIGURING the SERVER on page 7*.

Table 1 Capabilities and Features

Capability/Feature	Description
Chassis	The B460 M4 E7 v4 Blade Server mounts in a Cisco UCS 5100 series chassis and occupies four chassis slots (each chassis slot is a half-width slot).
CPU	Four Intel® Xeon® E7-8800 v4 or E7-4800 v4 series processor family CPUs.
Chipset	Intel® C602J chipset
Memory	96 slots (48 per Blade Module) for registered DIMMs (RDIMMs) or load-reduced DIMMs (LRDIMMs) . Maximum memory capacity is 6 TB. This is accomplished with 96 64 GB DIMMs.
Expansion slots	<p>Four dual-port slots and two quad-port mezzanine slot are provided that can accommodate PCIe compatible adapters.</p> <p>Two of the dual-port slots is dedicated for the VIC 1340 adapter, which provides Ethernet and Fibre Channel over Ethernet (FCoE)</p>
	 <p>NOTE: The Cisco VIC 1300 Series (1340 and 1380) is compatible with the 6200 Series Fabric Interconnects.</p>
Storage controller	<p>The other dual-port slot and the quad-port slot are used for various types of Cisco adapters and Cisco UCS Storage Accelerator adapters. The VIC 1380 can only be plugged into the quad-port slot.</p> <p>Two LSI SAS3008 12G SAS RAID controllers, one in each Blade Module, each providing 12 Gbps SAS connectivity as well as RAID 0, 1, and JBOD capability.</p>
Internal storage devices	<ul style="list-style-type: none"> ■ Up to four optional front-accessible, hot-swappable solid state drives (SSDs), two per Blade Module. ■ One optional USB flash drive, mounted inside the “Master” Blade Module. Note that the USB flash drive in the “Slave” Blade Module is not recognized. Only the USB flash drive in the “Master” Blade Module (bottom Blade Module) is recognized. ■ Dual sockets for optional Flexible Flash cards on the front left side of the “Master” Blade Module. Note that the USB card slot in the “Slave” Blade Module is not recognized. Only the USB card slot in the “Master” Blade Module (bottom Blade Module) is recognized.

Table 1 Capabilities and Features *(continued)*

Capability/Feature	Description
Video	<p>The Cisco Integrated Management Controller (CIMC) provides video using the Matrox G200e video/graphics controller:</p> <ul style="list-style-type: none"> ■ Integrated 2D graphics core with hardware acceleration ■ DDR2/3 memory interface supports up to 512 MB of addressable memory (8 MB is allocated by default to video memory) ■ Supports display resolutions up to 1920 x 1200 16bpp @ 60Hz ■ High-speed integrated 24-bit RAMDAC ■ Single lane PCI-Express host interface running at Gen 1 speed <p>Note that the two CIMCs (one in each server chassis) work together.</p>
Interfaces	<p>One front-accessible console connector on the master server chassis (see SUPPLEMENTAL MATERIAL on page 38)</p>
Power subsystem	<p>Integrated in the Cisco UCS 5100 series chassis</p>
Fans	<p>Integrated in the Cisco UCS 5100 series chassis</p>
Integrated management processor	<p>The built-in Cisco Integrated Management Controller (CIMC) GUI or CLI interface enables you to monitor the server inventory, health, and system event logs.</p>

CONFIGURING the SERVER

Follow these steps to configure the Cisco UCS B460 M4 E7 v4 Server:

- *STEP 1 VERIFY BASE SKU, page 8*
- *STEP 2 CHOOSE CPU(S), page 10*
- *STEP 3 CHOOSE MEMORY, page 12*
- *STEP 4 CHOOSE SOLID-STATE DRIVES (SSDs), page 18*
- *STEP 5 CHOOSE RAID CONFIGURATION, page 19*
- *STEP 6 CHOOSE ADAPTERS, page 20*
- *STEP 7 ORDER A TRUSTED PLATFORM MODULE (OPTIONAL), page 25*
- *STEP 8 ORDER CISCO FLEXIBLE FLASH SECURE DIGITAL CARDS, page 26*
- *STEP 11 CHOOSE OPERATING SYSTEM AND VALUE-ADDED SOFTWARE, page 29*
- *STEP 12 CHOOSE OPERATING SYSTEM MEDIA KIT, page 32*
- *STEP 13 CHOOSE SERVICE and SUPPORT LEVEL, page 33*

STEP 1 VERIFY BASE SKU

Verify the product ID (PID) of the base server as shown in [Table 2](#).

Table 2 PID of the Base B460 M4 E7 v4 Server

Product ID (PID)	Description
UCSB-EX-M4-3A	UCS Scalable M4 Blade Module w/o v4 CPU/DIMM/SSD for B460 M4

The B460 M4 E7 v4 base server:

- Includes two full-width Scalable M4 Blade Modules and a Scalability Connector that interconnects the two Blade Modules.
- Does not include CPUs, memory DIMMs, SSDs, or mezzanine cards.



NOTE: Use the steps on the following pages to configure the server with the components that you want to include.



NOTE: The B460 M4 E7 v4 server consists of two Scalable M4 Blade Modules and a Scalability Connector that cross-connects the two Blade Modules. The Blade Module on the bottom is the “Master” and the Blade Module on the top is the “Slave”. The optional USB flash and Flexible Flash cards must be mounted in the “Master” Blade Module of B460 M4 E7 v4 server; if they are in the “Slave” Blade Module, they are not recognized and do not operate.



NOTE: If the B460 M4 E7 v4 server is mixed with other full-width or half-width blades in the chassis, the B460 M4 E7 v4 must occupy the bottom two full-width slots in the chassis. The chassis should be loaded with the largest server on the bottom, starting with B460 M4 E7 v4 on the bottom, followed by full-width blades above, and the half-width blades at the very top of the chassis.

To upgrade from a B260 M4 E7 v4 server to a B460 M4 E7 v4 server:

- Order the upgrade kit (PID UCSB-EX-M4-3E-U), which consists of the following:
 - One Scalable M4 Blade Module
 - One Scalability Connector

- Configure the new Scalable M4 Blade Module with two Intel Xeon E7-8800 v4 or E7-4800 v4 series processor family CPU that are identical to the two processors in the B260 M4 E7 v4 server to be upgraded.



NOTE: The two CPUs in the original B260 E7 v4 M4 server and the two CPUs in the Scalable M4 Blade Module from the upgrade kit must be identical.

- Configure both Blade Modules with like kind DIMMs. All DIMMs must be either RDIMMs or LRDIMMs.
- Remove the Scalability Terminator from your original B260 M4 E7 v4. Install the new Scalable M4 Blade Module from the upgrade kit in the chassis slot above or below. Then install the new Scalability Connector into the front of both Blade Module, connecting them together. You now have a B460 M4 E7 v4 server, consisting of two Scalable M4 Blade Modules ganged together by the Scalability Connector.

STEP 2 CHOOSE CPU(S)

The standard CPU features are:

- Intel Xeon E7-8800 v4 or E7-4800 v4 series processor family CPUs
- Cache size of up to 60 MB

Choose CPUs

The available CPUs are listed in [Table 3](#).

Table 3 Available CPUs: Intel Xeon E7-8800 v4/E7-4800 v4 Family

Product ID (PID)	Intel Number	Clock Freq (GHz)	Power (W)	Cache Size (MB)	Cores	QPI (GT/s)	Highest DDR4 DIMM Clock Support (MHz)
UCS-CPU-E78894E	E7-8894 v4	2.4	165	60	24	9.6	1866
UCS-CPU-E78890E	E7-8890 v4	2.2	165	60	24	9.6	1866
UCS-CPU-E78880E	E7-8880 v4	2.2	150	55	22	9.6	1866
UCS-CPU-E78870E	E7-8870 v4	2.1	140	50	20	9.6	1866
UCS-CPU-E78860E	E7-8860 V4	2.2	140	45	18	9.6	1866
UCS-CPU-E74850E	E7-4850 V4	2.1	115	40	16	8.0	1866
UCS-CPU-E74830E	E7-4830 V4	2.0	115	35	14	8.0	1866
UCS-CPU-E74820E	E7-4820 V4	2.0	115	25	10	6.4	1866
UCS-CPU-E74809E	E7-4809 v4	2.1	115	20	8	6.4	1866
UCS-CPU-E78891E	E7-8891 v4	2.8	165	60	10	9.6	1866
UCS-CPU-E78893E	E7-8893 v4	3.2	140	60	4	9.6	1866
UCS-CPU-E78867E	E7-8867 v4	2.4	165	45	18	9.6	1866

Approved Configurations

(1) Four-CPU Configuration

- Choose four identical CPUs from any one row in [Table 3](#).

Caveats

- You must choose four identical CPUs.



NOTE: The B260 M4 server consists of a Scalable M4 Blade Module and a Scalability Terminator that plugs into the front of the blade module.

You can upgrade a B260 M4 E7 v4 blade server later to a B460 M4 E7 v4 server. See [To upgrade from a B260 M4 E7 v4 server to a B460 M4 E7 v4 server: on page 8](#) for details on upgrading.

STEP 3 CHOOSE MEMORY

The standard memory features are:

- DIMMs
 - Clock speed: 2400 or 2133 MHz
 - Ranks per DIMM: single, dual, or quad
 - Operational voltage: 1.2 V
 - Registered DIMM (RDIMM) or load-reduced DIMM (LRDIMM)
-



NOTE: You cannot mix RDIMMs with LRDIMMs within the same server.

- Each CPU controls four serial memory interface 2 (SMI-2) channels. Memory buffers convert each SMI-2 channel into two DDR4 subchannels. Memory is organized as 3 DIMMs per subchannel, totaling 6 DIMMs per SMI-2 channel. See [Figure 3](#).
-



NOTE: Memory mirroring is supported and settable using the UCSM Service Profile “Memory RAS Configuration” setting.

Figure 3 B460 M4 E7 v4 Memory Organization

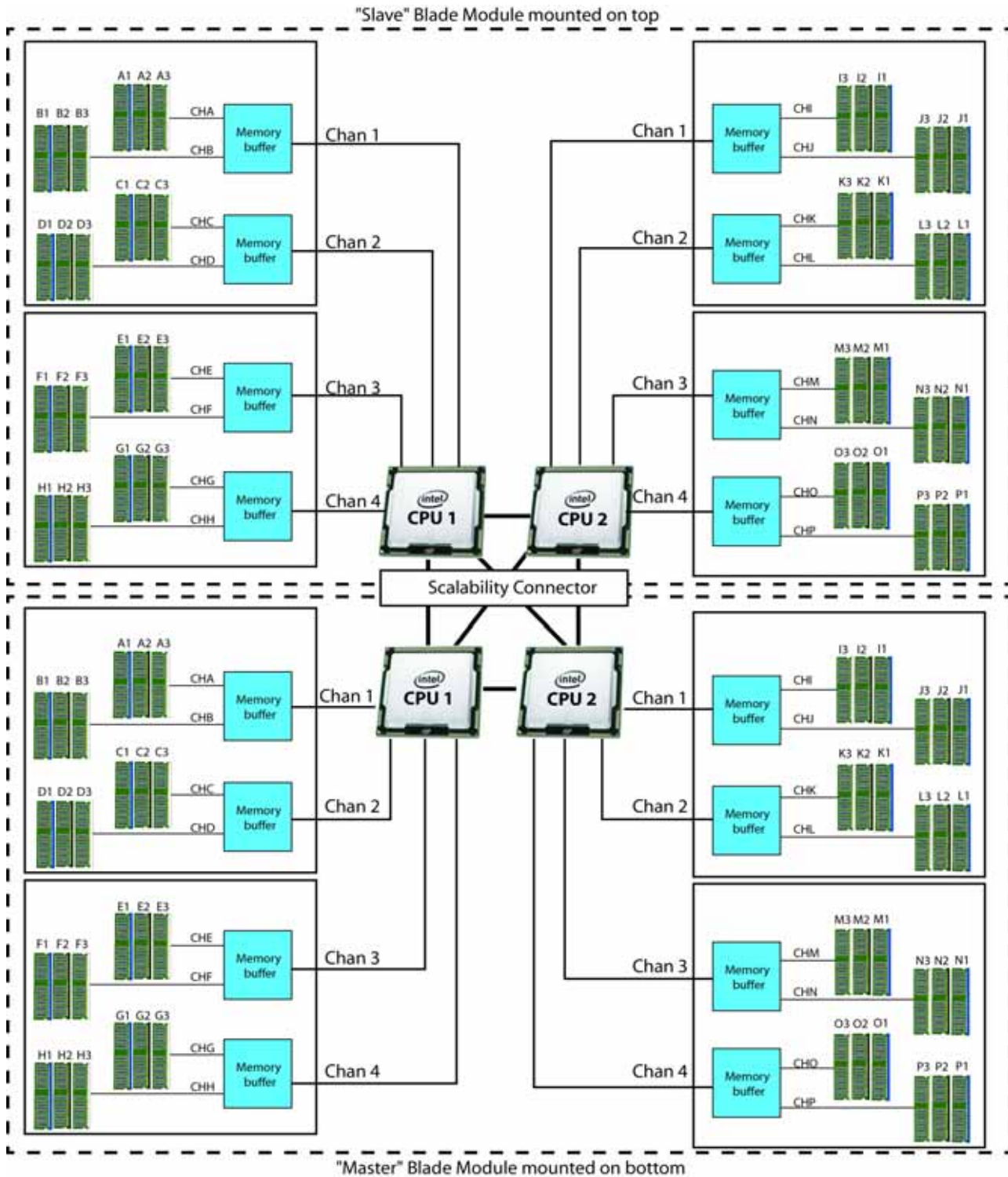

96 DIMMS, 6 TB maximum memory, 4 memory channels per CPU, up to 3 DIMMs per memory subchannel

Select DIMMs

Select DIMMs as desired from [Table 5](#).

Table 4 Available DDR4 DIMMs

Product ID (PID)	PID Description	Voltage	Ranks/ DIMM
DIMM Options			
UCS-ML-1X644RU-G	64GB DDR4-2133-MHz LRDIMM/PC4-17000/quad rank/x4	1.2 V	4
UCS-ML-1X324RU-G	32GB DDR4-2133-MHz LRDIMM/PC4-17000/quad rank/x4	1.2 V	4
UCS-MR-1X322RU-G	32GB DDR4-2133-MHz RDIMM/PC4-17000/dual rank/x4	1.2 V	2
UCS-MR-1X161RV-G	16GB DDR4-2400-MHz RDIMM/PC4-19200/single rank/x4	1.2 V	1
Memory Mirroring Option			
N01-MMIRROR	Memory mirroring option		

Approved Configurations

(1) 4-CPU Configuration

- 96 DIMMs capacity total, up to 24 DIMMs per CPU
- Select a minimum of 1 DIMM or a maximum of 24 DIMMs per CPU. The DIMMs for each CPU will be placed by the factory as shown in [Table 5](#). Refer also to [Figure 3 on page 13](#) and [DIMM and CPU Layout on page 40](#) for more information about DIMM placement and labeling.

Table 5 DIMM Population Order

DIMMs per CPU	CPU 1 DIMMs	CPU 2 DIMMs
1	(A1) - blue slot	(O1) - blue slot
2	(A1, B1) - blue slots	(O1, P1) - blue slots
3	(A1, B1) (C1) - blue slots	(O1, P1) (L1) - blue slots
4	(A1, B1) (C1, D1) - blue slots	(O1, P1) (L1, K1) - blue slots
5	(A1, B1) (C1, D1) (E1) - blue slots	(O1, P1) (L1, K1) (M1) - blue slots
6	(A1, B1) (C1, D1) (E1, F1) - blue slots	(O1, P1) (L1, K1) (M1, N1) - blue slots
7	(A1, B1) (C1, D1) (E1, F1) (G1) - blue slots	(O1, P1) (L1, K1) (M1, N1) (J1) - blue slots

Table 5 DIMM Population Order (*continued*)

DIMMs per CPU	CPU 1 DIMMs	CPU 2 DIMMs
8	(A1, B1) (C1, D1) (E1, F1) (G1, H1) - blue slots	(O1, P1) (L1, K1) (M1, N1) (J1, I1) - blue slots
9	(A1, B1) (C1, D1) (E1, F1) (G1, H1) - blue slots (A2) - black slot	(O1, P1) (L1, K1) (M1, N1) (J1, I1) - blue slots (O2) - black slot
10	(A1, B1) (C1, D1) (E1, F1) (G1, H1) - blue slots (A2, B2) - black slots	(O1, P1) (L1, K1) (M1, N1) (J1, I1) - blue slots (O2, P2) - black slots
11	(A1, B1) (C1, D1) (E1, F1) (G1, H1) - blue slots (A2, B2) (C2) - black slots	(O1, P1) (L1, K1) (M1, N1) (J1, I1) - blue slots (O2, P2) (L2) - black slots
12	(A1, B1) (C1, D1) (E1, F1) (G1, H1) - blue slots (A2, B2) (C2, D2) - black slots	(O1, P1) (L1, K1) (M1, N1) (J1, I1) - blue slots (O2, P2) (L2, K2) - black slots
13	(A1, B1) (C1, D1) (E1, F1) (G1, H1) - blue slots (A2, B2) (C2, D2) (E2) - black slots	(O1, P1) (L1, K1) (M1, N1) (J1, I1) - blue slots (O2, P2) (L2, K2) (M2) - black slots
14	(A1, B1) (C1, D1) (E1, F1) (G1, H1) - blue slots (A2, B2) (C2, D2) (E2, F2) - black slots	(O1, P1) (L1, K1) (M1, N1) (J1, I1) - blue slots (O2, P2) (L2, K2) (M2, N2) - black slots
15	(A1, B1) (C1, D1) (E1, F1) (G1, H1) - blue slots (A2, B2) (C2, D2) (E2, F2) (G2) - black slots	(O1, P1) (L1, K1) (M1, N1) (J1, I1) - blue slots (O2, P2) (L2, K2) (M2, N2) (J2) - black slots
16	(A1, B1) (C1, D1) (E1, F1) (G1, H1) - blue slots (A2, B2) (C2, D2) (E2, F2) (G2, H2) - black slots	(O1, P1) (L1, K1) (M1, N1) (J1, I1) - blue slots (O2, P2) (L2, K2) (M2, N2) (J2, I2) - black slots
17	(A1, B1) (C1, D1) (E1, F1) (G1, H1) - blue slots (A2, B2) (C2, D2) (E2, F2) (G2, H2) - black slots (A3) - white or ivory slots	(O1, P1) (L1, K1) (M1, N1) (J1, I1) - blue slots (O2, P2) (L2, K2) (M2, N2) (J2, I2) - black slots (O3) - white or ivory slots
18	(A1, B1) (C1, D1) (E1, F1) (G1, H1) - blue slots (A2, B2) (C2, D2) (E2, F2) (G2, H2) - black slots (A3, B3) - white or ivory slots	(O1, P1) (L1, K1) (M1, N1) (J1, I1) - blue slots (O2, P2) (L2, K2) (M2, N2) (J2, I2) - black slots (O3, P3) - white or ivory slots
18	(A1, B1) (C1, D1) (E1, F1) (G1, H1) - blue slots (A2, B2) (C2, D2) (E2, F2) (G2, H2) - black slots (A3, B3) (C3) - white or ivory slots	(O1, P1) (L1, K1) (M1, N1) (J1, I1) - blue slots (O2, P2) (L2, K2) (M2, N2) (J2, I2) - black slots (O3, P3) (L3) - white or ivory slots
20	(A1, B1) (C1, D1) (E1, F1) (G1, H1) - blue slots (A2, B2) (C2, D2) (E2, F2) (G2, H2) - black slots (A3, B3) (C3, D3) - white or ivory slots	(O1, P1) (L1, K1) (M1, N1) (J1, I1) - blue slots (O2, P2) (L2, K2) (M2, N2) (J2, I2) - black slots (O3, P3) (L3, K3) - white or ivory slots
21	(A1, B1) (C1, D1) (E1, F1) (G1, H1) - blue slots (A2, B2) (C2, D2) (E2, F2) (G2, H2) - black slots (A3, B3) (C3, D3) (E3) - white or ivory slots	(O1, P1) (L1, K1) (M1, N1) (J1, I1) - blue slots (O2, P2) (L2, K2) (M2, N2) (J2, I2) - black slots (O3, P3) (L3, K3) (M3) - white or ivory slots
22	(A1, B1) (C1, D1) (E1, F1) (G1, H1) - blue slots (A2, B2) (C2, D2) (E2, F2) (G2, H2) - black slots (A3, B3) (C3, D3) (E3, F3) - white or ivory slots	(O1, P1) (L1, K1) (M1, N1) (J1, I1) - blue slots (O2, P2) (L2, K2) (M2, N2) (J2, I2) - black slots (O3, P3) (L3, K3) (M3, N3) - white or ivory slots

Table 5 DIMM Population Order (continued)

DIMMs per CPU	CPU 1 DIMMs	CPU 2 DIMMs
23	(A1, B1) (C1, D1) (E1, F1) (G1, H1) - blue slots (A2, B2) (C2, D2) (E2, F2) (G2, H2) - black slots (A3, B3) (C3, D3) (E3, F3) (G3) - white or ivory slots	(O1, P1) (L1, K1) (M1, N1) (J1, I1) - blue slots (O2, P2) (L2, K2) (M2, N2) (J2, I2) - black slots (O3, P3) (L3, K3) (M3, N3) (J3) - white or ivory slots
24	(A1, B1) (C1, D1) (E1, F1) (G1, H1) - blue slots (A2, B2) (C2, D2) (E2, F2) (G2, H2) - black slots (A3, B3) (C3, D3) (E3, F3) (G3, H3) - white or ivory slots	(O1, P1) (L1, K1) (M1, N1) (J1, I1) - blue slots (O2, P2) (L2, K2) (M2, N2) (J2, I2) - black slots (O3, P3) (L3, K3) (M3, N3) (J3, I3) - white or ivory slots

Caveats

- **Memory Mode.** System speed is dependent on how many DIMMs are populated per channel and the BIOS memory mode. The BIOS default memory mode is performance mode. However, the BIOS can be changed to support lockstep mode.
 - **Memory Performance Mode.** In this mode, the main memory channel from the CPU to the memory buffer runs at double the clock rate of each of the two memory subchannels from the buffer to the DIMMs, and each DIMM subchannel is accessed sequentially. For example, if the CPU channel clock speed is 1866 MHz, each of the DIMM subchannels operates at 1333 MHz. For this reason, performance mode is referred to as 2:1. Performance mode does not provide data protection, but can yield up to 1.5 times the performance of lockstep mode and is the best choice for high throughput requirements.
 - **Memory Lockstep Mode.** In this mode, the main memory channel from the CPU to the memory buffer runs at the same clock rate of each of the two memory subchannels from the buffer to the DIMMs, and both DIMM subchannels are accessed simultaneously for a double-width access. For example, if the CPU channel clock speed is 1600 MHz, each of the DIMM subchannels operates at 1600 MHz. For this reason, lockstep mode is referred to as 1:1. Memory lockstep mode provides protection against both single-bit and multi-bit errors. Memory lockstep lets two memory channels work as a single channel, moving a data word two channels wide and providing eight bits of memory correction.
- **DIMM Clock Speeds**

DIMMs run at various clock speeds depending on the number of DIMMs per channel. See [Table 6](#).

Table 6 DIMM Performance (at 1.2 V)

DIMM GB/Rank/Type	Performance Mode (2:1) 1.2 V DIMM			Lockstep Mode (1:1) 1.2 V DIMM		
	1 DPC	2 DPC	3 DPC	1 DPC	2 DPC	3 DPC
16 GB/1R/RDIMM	1600	1600	1600	1866	1866	1600
32 GB/2R/RDIMM	1600	1600	1333	1866	1866	1333
32 GB/4R/LRDIMM	1600	1600	1600	1866	1866	1600
64 GB/4R/LRDIMM	1600	1600	1600	1866	1866	1600

- The only supported DIMM configurations are shown in [Table 5 on page 14](#). For best results, follow the DIMM population rules.
- The B460 M4 E7 v4 server needs at least one DIMM installed for each CPU.
- Memory DIMMs must be installed evenly across the installed CPUs.
- Do not mix RDIMMs and LRDIMMs within the same server.
- For DIMM size mixing rules, see [Table 23 on page 42](#).

STEP 4 CHOOSE SOLID-STATE DRIVES (SSDs)

The standard disk drive features are:

- 7 mm high Small form factor (SFF) SSDs (HDDs are not supported on this server)
- Hot-pluggable
- Sled-mounted

Choose Drives

The available drives are listed in [Table 7](#).



NOTE: 4K format drives are supported and qualified as bootable with Cisco UCS Manager Release 3.1(2b) and later versions.

Table 7 Available Hot-Swappable Sled-Mounted SSDs

Product ID (PID)	PID Description	Drive Type	Capacity
SSDs			
UCS-SD19TBKSS-EV	1.9 TB 2.5 inch Enterprise Value 6G SATA SSD (1 FWPD)(PM863)	SATA	1.9 TB
UCS-SD16TB7M-EV	1.6 TB 7mm Enterprise Value SSD	SATA	1.6 TB
UCS-SD480GBKSS-EV	480 GB 2.5 in Enterprise Value 6G SATA SSD (1FWPD) (PM86)	SATA	480 GB
UCS-SD480GB7M-EP	480 GB 7mm Enterprise Performance SSD	SATA	480 GB
UCS-SD120GB7M-EV	120 GB 7mm Enterprise Value SSD	SATA	120 GB

Approved Configurations

(1) Zero to Four Drives

- Select from 0 to 4 drives from [Table 7](#). You can select up to 2 drives per Blade Module.

Caveats

- SSDs of different classes (for example, an Enterprise Performance SSD and an Enterprise Value SSD) can be mixed within the server.
- SSDs of different capacities (for example, a 480 GB SSD and a 1.6TB SSD) can be mixed within the server.
- See [STEP 5 CHOOSE RAID CONFIGURATION, page 19](#) for available RAID configurations.

STEP 5 CHOOSE RAID CONFIGURATION

The B460 M4 E7 v4 chassis integrates the LSI SAS3008 12G SAS RAID controller (one in each Blade Module), which provides RAID 0/1 capability.

Caveats

- For each Blade Module, RAID configuration is possible if you have two identical drives. Otherwise, a JBOD configuration is supported.
- A RAID configuration cannot be built with drives residing in different Blade Modules.

STEP 6 CHOOSE ADAPTERS

The adapter offerings are:

■ Cisco Virtual Interface Cards (VICs)

Cisco has developed 1300 Series Virtual Interface Cards (VICs) to provide flexibility to create multiple NIC and HBA devices. The VICs also support adapter Fabric Extender and Virtual Machine Fabric Extender technologies. The VIC features are listed here:

- 1300 Series VICs include all of the 1200 Series features plus additional enhancements including network overlay offload support for NVGRE and VXLAN, and RoCE services.
- In addition, 1300 Series VICs support PCIe Gen 3.0 for greater bandwidth than 1200 Series VICs
- Two Converged Network Adapter (CNA) ports, supporting both Ethernet and FCoE
- Delivers 80 Gbps total I/O throughput to the server
 - VIC 1340 supports dual 4x 10 Gbps Unified I/O ports or 2x40 (native) Gbps Unified I/O ports
- Creates up to 256 fully functional unique and independent PCIe adapters and interfaces (NICs or HBAs) without requiring single-root I/O virtualization (SR-IOV) support from operating systems or hypervisors
- Provides virtual machine visibility from the physical network and a consistent network operations model for physical and virtual servers
- Supports customer requirements for a wide range of operating systems and hypervisors

■ Cisco UCS Storage Accelerator Adapters

Cisco UCS Storage Accelerator adapters are designed specifically for the Cisco UCS B-series M4 blade servers and integrate seamlessly to allow improvement in performance and relief of I/O bottlenecks.



NOTE: There are three slots in each of the two Blade Modules of the server. One is a dedicated slot for the VIC 1340 adapter only and the other two other Cisco adapters. [Table 8](#) shows which adapters plug into each of the three slots.

Table 8 shows the supported adapters.

To help ensure that your operating system is compatible with the cards you have selected, please check the Hardware Compatibility List at this URL:

http://www.cisco.com/en/US/products/ps10477/prod_technical_reference_list.html

Choose Adapters

The supported mezzanine adapters in each UCS B460 M4 E7 v4 are listed in *Table 8*.

Table 8 Supported Mezzanine Adapters

Product ID (PID)	PID Description	Connector ¹
Virtual Interface Cards (VICs)		
UCSB-MLOM-40G-03 ²	Cisco UCS VIC 1340 modular LOM for blade servers	Adapter 1
UCSB-VIC-M83-8P ¹	Cisco UCS VIC 1380 mezzanine adapter	Adapter 3
Cisco Storage Accelerators		
UCSB-F-FIO-1600MS	UCS 1600 GB Fusion ioMemory3 SX Scale line for B-Series	Adapter 2 or Adapter 3
UCSB-F-FIO-1300MP	UCS 1300 GB Fusion ioMemory3 PX Performance line for B-Series	Adapter 2 or Adapter 3
Port Expander Card for VIC Option		
UCSB-MLOM-PT-01	Cisco UCS Port Expander Card for VIC. This is a hardware option to enable an additional 4 ports of the VIC 1340, bringing the total capability of the VIC 1340 to dual 4 x 10 GbE	Adapter 2

Notes . . .

1. “Adapter 1,” “Adapter 2,” and “Adapter 3” refer to the UCSM naming convention for the adapter slots (this document uses the UCSM naming convention). In the server BIOS and on the motherboard, the corresponding slots are labeled as “mLOM,” “Mezz 1,” and “Mezz 2,” respectively. See *Table 9*.
2. The VIC 1340/1380 are only supported with the 6299 Series Fabric Interconnects. They are not supported with the 6100 Series Fabric Interconnects.

Table 9 Adapter Slot Naming and Bandwidth

Server BIOS and Motherboard Slot Naming	UCSM Slot Naming	Available Bandwidth
mLOM (VIC 1340 only)	Adapter 1	20 Gbps per Fabric Extender
Mezz1	Adapter 2	20 Gbps per Fabric Extender
Mezz2	Adapter 3	40 Gbps per Fabric Extender

Supported Configurations

Table 10 shows the supported adapter combinations. The configuration rules for each B460 M4 Blade Module are summarized as follows:

- Adapter slot 1 is dedicated for the VIC 1340 only. No other mezzanine card can fit in Adapter Slot 1.
- The Port Expander Card can only be selected if the VIC 1340 is also selected for the server.
- You must select at least one VIC. You may select up to four VICs.
- You cannot select more than two VIC 1340s. You cannot select more than two VIC 1380s.
- You can select up to four Storage Acceleration adapters.
- The VIC 1380 can only be installed in Adapter slot 3.

Select an adapter combination according to [Table 10](#).



NOTE: The table shows supported configurations for each Blade Module. At least one of the Blade Modules must be configured for network connectivity (a VIC 1340 at a minimum must be installed). If one Blade Module has network connectivity, network connectivity for the remaining Blade Module is optional



NOTE: CPU 1 controls adapter slot 1, and CPU 2 controls adapter slots 2 and 3.

Table 10 Supported 1340 and 1380 Adapter¹ Combinations (for each blade module)

Adapter Configurations			Fabric Extenders Aggregate Bandwidth (Gb/s)			Fabric Interconnects ²	
Adapter Slot 1	Adapter Slot 2	Adapter Slot 3	2 x 2304	2 x 2208XP	2 x 2204XP	2 x 63xx	2 x 62xx
Two VICs (VIC 1340 + VIC 1380)							
VIC 1340	Port Expander Card	VIC 1380	160	160	80	63xx	62xx
VIC 1340	Cisco UCS Storage Accelerator	VIC 1380	160	120	60	63xx	62xx
VIC 1340	Not populated	VIC 1380	120	120	60	63xx	62xx
One VIC (VIC 1380)							
Not populated	Cisco UCS Storage Accelerator	VIC 1380	80	80	40	63xx	62xx
Not populated	Not populated	VIC 1380	80	80	40	63xx	62xx
One VIC (VIC 1340)							
VIC 1340	Port Expander Card	Cisco UCS Storage Accelerator	80	80	40	63xx	62xx
VIC 1340	Port Expander Card	Not populated	80	80	40	63xx	62xx

Table 10 Supported 1340 and 1380 Adapter¹ Combinations (for each blade module) *(continued)*

Adapter Configurations			Fabric Extenders Aggregate Bandwidth (Gb/s)			Fabric Interconnects ²	
Adapter Slot 1	Adapter Slot 2	Adapter Slot 3	2 x 2304	2 x 2208XP	2 x 2204XP	2 x 63xx	2 x 62xx
VIC 1340	Cisco UCS Storage Accelerator	Cisco UCS Storage Accelerator	80	40	20	63xx	62xx
VIC 1340	Cisco UCS Storage Accelerator	Not populated	80	40	20	63xx	62xx
VIC 1340	Not populated	Not populated	40	40	20	63xx	62xx

Notes . . .

1. In the server BIOS and on the motherboard, “Adapter 1,” “Adapter 2,” and “Adapter 3” are labeled as “mLOM,” “Mezz 1,” and “Mezz 2,” respectively
2. 61xx Fabric Extenders are not supported

To check that your operating system is compatible with the adapter you have selected, please check the Hardware Compatibility List at this URL

http://www.cisco.com/en/US/products/ps10477/prod_technical_reference_list.html

STEP 7 ORDER A TRUSTED PLATFORM MODULE (OPTIONAL)

Trusted Platform Module (TPM) is a computer chip (microcontroller) that can securely store artifacts used to authenticate the platform (server). These artifacts can include passwords, certificates, or encryption keys. A TPM can also be used to store platform measurements that help ensure that the platform remains trustworthy. Authentication (ensuring that the platform can prove that it is what it claims to be) and attestation (a process helping to prove that a platform is trustworthy and has not been breached) are necessary steps to ensure safer computing in all environments.

The TPM ordering information is listed in [Table 11](#).

Table 11 Trusted Platform Module

Product ID (PID)	PID Description
UCSX-TPM1-001	Trusted Platform Module 1.2 for UCS
UCSX-TPM1-002	Trusted Platform Module 2.0 for UCS servers (LPC based)



NOTE: The B460 M4 E7 v4 requires two TPMs, one in each of the two Blade Modules.



NOTE: The module used in this server conforms to TPM v1.2/2.0, as defined by the Trusted Computing Group (TCG).



NOTE: TPM installation is supported after-factory. However, a TPM installs with a one-way screw and cannot be replaced, upgraded, or moved to another server. If a server with a TPM is returned, the replacement server must be ordered with a new TPM.

STEP 8 ORDER CISCO FLEXIBLE FLASH SECURE DIGITAL CARDS

Dual SDHC Flexible Flash card sockets are provided on the left side of the server, near the front. The SDHC card ordering information is listed in [Table 12](#). Order one or two identical SD cards.

Table 12 Supported Configurations - Flexible Flash Card(s)

Product ID (PID)	PID Description
UCS-SD-32G-S=	32 GB SD Card module for UCS Servers
UCS-SD-64G-S=	64 GB SD card for UCS servers



NOTE: SDHC Flexible Flash cards must be ordered as spares and are to be installed in the bottom (Master) blade module after the server is assembled.

Caveats

- Do not mix 32 GB SD cards with 64 GB SD cards.

STEP 9 ORDER OPTIONAL INTERNAL USB 2.0 DRIVE

You may order one optional internal USB 2.0 drive. The USB drive ordering information is listed in [Table 13](#).

Table 13 USB 2.0 Drive

Product ID (PID)	PID Description
UCS-USBFLSHB-16GB=	UCS Servers 16 GB Flash USB Drive



NOTE: USB drives must be ordered as spares and are to be installed in the bottom (Master) blade module after the server is assembled.



NOTE: A clearance of 0.950 inches (24.1 mm) is required for the USB device to be inserted and removed (see the following figure).

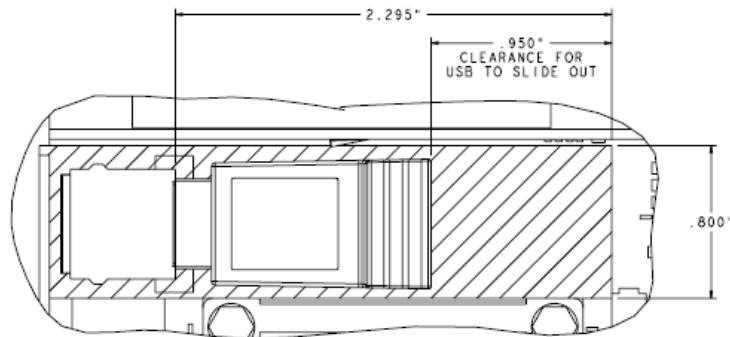

See [Figure 5 on page 38](#) for the location of the USB connector.

STEP 10 ORDER OPTIONAL KVM CABLE

The KVM cable provides a connection into the server, providing a DB9 serial connector, a VGA connector for a monitor, and dual USB 2.0 ports for a keyboard and mouse. With this cable, you can create a direct connection to the operating system and the BIOS running on the server.



NOTE: You can connect only one KVM cable to the B460 M4 E7 v4, and it must be connected to the lower (master) chassis only.

The KVM cable ordering information is listed in [Table 14](#).

Table 14 KVM Cable

Product ID (PID)	PID Description
37-1016-01	KVM Cable

Figure 4 KVM Cable

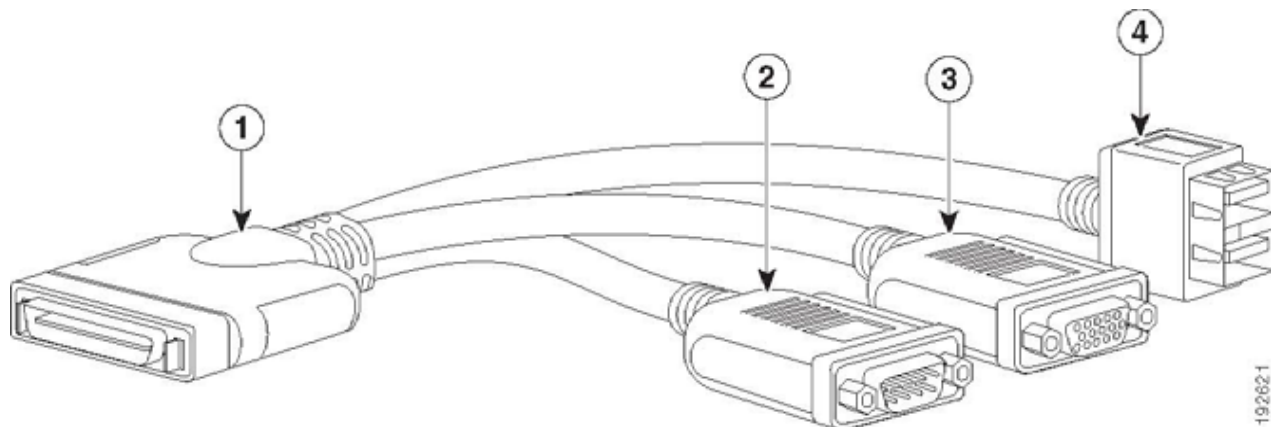

192621

1	Connector (to server front panel)	3	VGA connector (for a monitor)
2	DB-9 serial connector	4	Two-port USB 2.0 connector (for a mouse and keyboard)

STEP 11 CHOOSE OPERATING SYSTEM AND VALUE-ADDED SOFTWARE

Several software programs are available. Select as desired from [Table 15](#).

Table 15 OSs and Value-Added Software

PID Description	Product ID (PID)
Cisco One	
C1F2PUCSK9	Cisco ONE Foundation Perpetual UCS
C1A1PUCSK9	Cisco ONE Enterprise Cloud Perpetual UCS
C1UCS-OPT-OUT	Cisco One Data Center Compute Opt Out Option
Energy Management (JouleX)	
CEM-DC-ENERGY	Cisco Energy Management(JouleX) DataCenter License 1 Device More
UCS Director	
CUIC-PHY-SERV-BM-U	Cisco UCS Director Resource Lic - 1 Phy Sevr node bare metal
CUIC-PHY-SERV-U	Cisco UCS Director Resource Lic - One physical Server node
CUIC-TERM	Acceptance of Cisco UCS Director License Terms
UCS Performance Manager	
UCS-PM-IE	UCS Performance Manager
UCS-PM-EE	UCS Performance Manager Express
EVAL-UCS-PM-IE	UCS Performance Manager - 90 days evaluation
EVAL-UCS-PM-EE	UCS Performance Manager Express - 90 days evaluation
Nexus 1000V for Hyper-V and vSphere	
N1K-VSG-UCS-BUN	Nexus 1000V Adv Edition for vSphere Paper License Qty 1
IMC Supervisor	
CIMC-SUP-B10	IMC Supervisor- Branch Mgt SW for C & E-Series up to 1K Svrs
CIMC-SUP-B02	IMC Supervisor- Branch Mgt SW for C & E-Series up to 250 Svrs
UCS Multi-Domain Manager	
UCS-MDMGR-100S	UCS Multi-Domain Manager (Central) Per Server License (100+)
UCS-MDMGR-50S	UCS Multi-Domain Manager (Central) Per Server License (50+)
UCS-MDMGR-1S	UCS Multi-Domain Manager (Central) Per Server License
UCS-MDMGR-10S	UCS Multi-Domain Manager (Central) Per Server License (10+)
UCS-MDMGR-1DMN	UCS Multi-Domain Manager (Central) Per Domain License
VMware vCenter	
VMW-VCS-STD-1A	VMware vCenter 6 Server Standard, 1 yr support required
VMW-VCS-STD-3A	VMware vCenter 6 Server Standard, 3 yr support required
VMW-VCS-STD-5A	VMware vCenter 6 Server Standard, 5 yr support required
VMW-VCS-FND-1A	VMware vCenter 6 Server Foundation (3 Host), 1 yr supp reqd
VMW-VCS-FND-3A	VMware vCenter 6 Server Foundation (3 Host), 3 yr supp reqd
VMW-VCS-FND-5A	VMware vCenter 6 Server Foundation (3 Host), 5 yr supp reqd

Table 15 OSs and Value-Added Software (continued)

PID Description	Product ID (PID)
Microsoft Windows Server	
MSWS-12-ST2S	Windows Server 2012 Standard (2 CPU/2 VMs)
MSWS-12-DC2S	Windows Server 2012 Datacenter (2 CPU/Unlimited VMs)
MSWS-12-ST2S-NS	Windows Server 2012 Standard (2 CPU/2 VMs) No Cisco Svc
MSWS-12-DC2S-NS	Windows Server 2012 Datacenter (2 CPU/Unlim VM) No Cisco Svc
MSWS-12R2-ST2S	Windows Server 2012 R2 Standard (2 CPU/2 VMs)
MSWS-12R2-DC2S	Windows Server 2012 R2 Datacenter (2 CPU/Unlimited VMs)
MSWS-12R2-ST2S-NS	Windows Server 2012 R2 Standard (2 CPU/2 VMs) No Cisco SVC
MSWS-12R2-DC2S-NS	Windows Server 2012 R2 Databcen (2 CPU/Unlim VM) No Cisco Svc
Red Hat	
RHEL-2S2V-3A	Red Hat Enterprise Linux (1-2 CPU,1-2 VN); 3-Yr Support Req
RHEL-2S2V-1A	Red Hat Enterprise Linux (1-2 CPU,1-2 VN); 1-Yr Support Req
VMware	
VMW-VSP-EPL-5A	VMware vSphere 6 Ent Plus (1 CPU), 5-yr, Support Required
VMW-VSP-STD-1A	VMware vSphere 6 Standard (1 CPU), 1-yr, Support Required
VMW-VSP-STD-3A	VMware vSphere 6 Standard (1 CPU), 3-yr, Support Required
VMW-VSP-EPL-3A	VMware vSphere 6 Ent Plus (1 CPU), 3-yr, Support Required
VMW-VSP-EPL-1A	VMware vSphere 6 Ent Plus (1 CPU), 1-yr, Support Required
VMW-VSP-STD-5A	VMware vSphere 6 Standard (1 CPU), 5-yr, Support Required
SLES SAP	
SLES-SAP-2S2V-1S	SLES for SAP Apps (1-2 CPU, 1-2 VM); Priority 1-Yr SnS
SLES-SAP-2SUV-1S	SLES for SAP Apps (1-2 CPU, Unl VM); Priority 1-Yr SnS
SLES-SAP-2S2V-3S	SLES for SAP Apps (1-2 CPU, 1-2 VM); Priority 3-Yr SnS
SLES-SAP-2SUV-3S	SLES for SAP Apps (1-2 CPU, Unl VM); Priority 3-Yr SnS
SLES-SAP-2S2V-5S	SLES for SAP Apps (1-2 CPU, 1-2 VM); Priority 5-Yr SnS
SLES-SAP-2SUV-5S	SLES for SAP Apps (1-2 CPU, Unl VM); Priority 5-Yr SnS
SLES-SAP-2S2V-5A	SLES for SAP Apps (1-2 CPU, 1-2 VM); 5-Yr Support Reqd
SLES-SAP-2SUV-3A	SLES for SAP Apps (1-2 CPU, Unl VM); 3-Yr Support Reqd
SLES-SAP-2S2V-3A	SLES for SAP Apps (1-2 CPU, 1-2 VM); 3-Yr Support Reqd
SLES-SAP-2SUV-5A	SLES for SAP Apps (1-2 CPU, Unl VM); 5-Yr Support Reqd
SLES-SAP-2S2V-1A	SLES for SAP Apps (1-2 CPU, 1-2 VM); 1-Yr Support Reqd
SLES-SAP-2SUV-1A	SLES for SAP Apps (1-2 CPU, Unl VM); 1-Yr Support Reqd
SUSE	
SLES-2S2V-1A	SUSE Linux Enterprise Svr (1-2 CPU,1-2 VM); 1-Yr Support Req
SLES-2SUV-1A	SUSE Linux Enterprise Svr (1-2 CPU,Unl VM); 1-Yr Support Req
SLES-2S2V-3A	SUSE Linux Enterprise Svr (1-2 CPU,1-2 VM); 3-Yr Support Req
SLES-2SUV-3A	SUSE Linux Enterprise Svr (1-2 CPU,Unl VM); 3-Yr Support Req

Table 15 OSs and Value-Added Software (continued)

PID Description	Product ID (PID)
SLES-2S2V-5A	SUSE Linux Enterprise Svr (1-2 CPU,1-2 VM); 5-Yr Support Req
SLES-2SUV-5A	SUSE Linux Enterprise Svr (1-2 CPU,Unl VM); 5-Yr Support Req
SLES-2S2V-1S	SUSE Linux Enterprise Svr (1-2 CPU,1-2 VM); Prio 1-Yr SnS
SLES-2SUV-1S	SUSE Linux Enterprise Svr (1-2 CPU,Unl VM); Prio 1-Yr SnS
SLES-2S2V-3S	SUSE Linux Enterprise Svr (1-2 CPU,1-2 VM); Prio 3-Yr SnS
SLES-2SUV-3S	SUSE Linux Enterprise Svr (1-2 CPU,Unl VM); Prio 3-Yr SnS
SLES-2S2V-5S	SUSE Linux Enterprise Svr (1-2 CPU,1-2 VM); Prio 5-Yr SnS
SLES-2SUV-5S	SUSE Linux Enterprise Svr (1-2 CPU,Unl VM); Prio 5-Yr SnS
SLES-2S-HA-1S	SUSE Linux High Availability Ext (1-2 CPU); 1yr SnS
SLES-2S-HA-3S	SUSE Linux High Availability Ext (1-2 CPU); 3yr SnS
SLES-2S-HA-5S	SUSE Linux High Availability Ext (1-2 CPU); 5yr SnS
SLES-2S-GC-1S	SUSE Linux GEO Clustering for HA (1-2 CPU); 1yr Sns
SLES-2S-GC-3S	SUSE Linux GEO Clustering for HA (1-2 CPU); 3yr SnS
SLES-2S-GC-5S	SUSE Linux GEO Clustering for HA (1-2 CPU); 5yr SnS

STEP 12 CHOOSE OPERATING SYSTEM MEDIA KIT

Choose the optional operating system media listed in [Table 16](#).

Table 16 OS Media

Product ID (PID)	PID Description
RHEL-6	RHEL 6 Recovery Media Only (Multilingual)
SLES-11	SLES 11 media only (multilingual)
MSWS-08R2-STHV-RM	Windows Svr 2008 R2 ST (1-4CPU, 5CAL), Media
MSWS-08RS-ENHV-RM	Windows Svr 2008 R2 EN (1-8CPU, 25CAL), Media
MSWS-08R2-DCHV-RM	Windows Svr 2008 R2 DC (1-8CPU, 25CAL), Media
MSWS-12-ST2S-RM	Windows Server 2012 Standard (2 CPU/2 VMs) Recovery Media
MSWS-12-DC2S-RM	Windows Server 2012 Datacenter (2 CPU/Unlimited VM) Rec Media
MSWS-12R2-ST2S-RM	Windows Server 2012 R2 Standard (2 CPU/2 VMs) Recovery Media
MSWS-12R2-DC2S-RM	Windows Server 2012 R2 Datacen(2 CPU/Unlimited VM) Rec Media

STEP 13 CHOOSE SERVICE and SUPPORT LEVEL

A variety of service options are available, as described in this section.



NOTE: Because the B460 M4 E7 v4 server is structurally two Scalable M4 Blade Modules connected by means of the Scalability Connector, separate support for each of the two Scalable M4 Blade Modules in the B460 M4 E7 v4 server configuration is automatically purchased when you order support for the B460 M4 E7 v4 server. The online ordering tool enforces that the service level is always the same (for example, SNTP) for both Scalable M4 Blade Modules. If you change the service level, the new service level is applied to both Scalable M4 Blade Modules so that they remain the same.

In addition, there are no separate, single-support SKUs for the B460 M4 E7 v4 server or for the Scalability Connector.

Unified Computing Warranty, No Contract

If you have noncritical implementations and choose to have no service contract, the following coverage is supplied:

- Three-year parts coverage.
- Next business day (NBD) onsite parts replacement eight hours a day, five days a week.
- 90-day software warranty on media.
- Ongoing downloads of BIOS, drivers, and firmware updates.
- UCSM updates for systems with Unified Computing System Manager. These updates include minor enhancements and bug fixes that are designed to maintain the compliance of UCSM with published specifications, release notes, and industry standards.

SMARTnet for UCS

For support of the entire Unified Computing System, Cisco offers the Cisco SMARTnet for UCS Service. This service provides expert software and hardware support to help sustain performance and high availability of the unified computing environment. Access to Cisco Technical Assistance Center (TAC) is provided around the clock, from anywhere in the world.

For UCS blade servers, there is Smart Call Home, which provides proactive, embedded diagnostics and real-time alerts. For systems that include Unified Computing System Manager, the support service includes downloads of UCSM upgrades. The Cisco SMARTnet for UCS Service includes flexible hardware replacement options, including replacement in as little as two hours. There is also access to Cisco’s extensive online technical resources to help maintain optimal efficiency and uptime of the unified computing environment. You can choose a desired service listed in [Table 17](#).

Table 17 Cisco SMARTnet for UCS Service

Service SKU	On Site?	Description
CON-PREM-B260M4	Yes	ONSITE 24X7X2 UCS Blade Module for B260/B460 M4
CON-OSP-B260M4	Yes	ONSITE 24X7X4 UCS Blade Module for B260/B460 M4
CON-OSE-B260M4	Yes	ONSITE 8X5X4 UCS Blade Module for B260/B460 M4
CON-OS-B260M4	Yes	ONSITE 8X5XNBD UCS Blade Module for B260/B460 M4
CON-S2P-B260M4	No	SMARTNET 24X7X2 UCS Blade Module for B260/B460 M4
CON-SNTP-B260M4	No	SMARTNET 24X7X4 UCS Blade Module for B260/B460 M4
CON-SNTE-B260M4	No	SMARTNET 8X5X4 UCS Blade Module for B260/B460 M4
CON-SNT-B260M4	No	SMARTNET 8X5XNBD UCS Blade Module for B260/B460 M4

SMARTnet for UCS Hardware Only Service

For faster parts replacement than is provided with the standard Cisco Unified Computing System warranty, Cisco offers the Cisco SMARTnet for UCS Hardware Only Service. You can choose from two levels of advanced onsite parts replacement coverage in as little as four hours. SMARTnet for UCS Hardware Only Service provides remote access any time to Cisco support professionals who can determine if a return materials authorization (RMA) is required. You can choose a service listed in [Table 18](#).

Table 18 SMARTnet for UCS Hardware Only Service

Service SKU	Service Level GSP	On Site?	Description
CON-UCW7-B260M4	UCW7	Yes	UC PLUS 24X7X4OS UCS Blade Module for B260/B460 M4
CON-UCW5-B260M4	UCW5	Yes	UC PLUS 8X5XNBDOS UCS Blade Module for B260/B460 M4

Unified Computing Partner Support Service

Cisco Partner Support Service (PSS) is a Cisco Collaborative Services service offering that is designed for partners to deliver their own branded support and managed services to enterprise customers. Cisco PSS provides partners with access to Cisco's support infrastructure and assets to help them:

- Expand their service portfolios to support the most complex network environments
- Lower delivery costs
- Deliver services that increase customer loyalty

Partner Unified Computing Support Options enable eligible Cisco partners to develop and consistently deliver high-value technical support that capitalizes on Cisco intellectual assets. This helps partners to realize higher margins and expand their practice.

Partner Unified Computing Support Options are available to Cisco PSS partners. For additional information, see the following URL:

www.cisco.com/go/partnerucssupport

The two Partner Unified Computing Support Options include:

- Partner Support Service for UCS
- Partner Support Service for UCS Hardware Only

Partner Support Service for UCS provides hardware and software support, including triage support for third party software, backed by Cisco technical resources and level three support. See [Table 19](#).

Table 19 Partner Support Service for UCS

Service SKU	Service Level GSP	On Site?	Description
CON-PSJ1-B260M4	PSJ1	No	UCS SUPP PSS 8X5XNBD UCS Blade Module for B260/B460 M4
CON-PSJ2-B260M4	PSJ2	No	UCS SUPP PSS 8X5X4 UCS Blade Module for B260/B460 M4
CON-PSJ3-B260M4	PSJ3	No	UCS SUPP PSS 24X7X4 UCS Blade Module for B260/B460 M4
CON-PSJ4-B260M4	PSJ4	No	UCS SUPP PSS 24X7X2 UCS Blade Module for B260/B460 M4
CON-PSJ6-B260M4	PSJ6	Yes	UCS SUPP PSS 8x5x4 Onsite UCS Blade Module for B260/B460 M4
CON-PSJ7-B260M4	PSJ7	Yes	UCS SUPP PSS 24X7X4 Onsite UCS Blade Module for B260/B460 M4
CON-PSJ8-B260M4	PSJ8	Yes	UCS SUPP PSS 24X7X2 Onsite UCS Blade Module for B260/B460 M4

Partner Support Service for UCS Hardware Only provides customers with replacement parts in as little as two hours. See [Table 20](#).

Table 20 Partner Support Service for UCS (Hardware Only)

Service SKU	Service Level GSP	On Site?	Description
CON-PSW2-B260M4	PSW2	No	UCS W PL PSS 8X5X4 UCS Blade Module for B260/B460 M4
CON-PSW3-B260M4	PSW3	No	UCS W PL PSS 24X7X4 UCS Blade Module for B260/B460 M4
CON-PSW4-B260M4	PSW4	No	UCS W PL PSS 24X7X2 UCS Blade Module for B260/B460 M4
CON-PSW6-B260M4	PSW6	Yes	UCS HW ONLY PSS 8x5x4 Onsite UCS Blade Module for B260/B460 M4
CON-PSW7-B260M4	PSW7	Yes	UCS HW ONLY PSS 24x7x4 Onsite UCS Blade Module for B260/B460 M4

Cisco Combined Services

Combined Services makes it easier to purchase and manage required services under one contract. SMARTnet services for UCS help increase the availability of your vital data center infrastructure and realize the most value from your unified computing investment. The more benefits you realize from the Cisco Unified Computing System (Cisco UCS), the more important the technology becomes to your business. These services allow you to:

- Optimize the uptime, performance, and efficiency of your UCS
- Protect your vital business applications by rapidly identifying and addressing issues
- Strengthen in-house expertise through knowledge transfer and mentoring
- Improve operational efficiency by allowing UCS experts to augment your internal staff resources
- Enhance business agility by diagnosing potential issues before they affect your operations

Unified Computing Drive Retention Service

With the Cisco Unified Computing Drive Retention (UCDR) Service, you can obtain a new disk drive in exchange for a faulty drive without returning the faulty drive. In exchange for a Cisco replacement drive, you provide a signed Certificate of Destruction (CoD) confirming that the drive has been removed from the system listed, is no longer in service, and has been destroyed.

Sophisticated data recovery techniques have made classified, proprietary, and confidential information vulnerable, even on malfunctioning disk drives. The UCDR service enables you to retain your drives and ensures that the sensitive data on those drives is not compromised, which reduces the risk of any potential liabilities. This service also enables you to comply with regulatory, local, and federal requirements.

If your company has a need to control confidential, classified, sensitive, or proprietary data, you might want to consider one of the Drive Retention Services listed in [Table 21](#), [Table 22](#), or [Table 23](#).



NOTE: Cisco does not offer a certified drive destruction service as part of this service.

Table 21 Drive Retention Service Options

Service Description	Service Program Name	Service Level GSP	Service Level	Product ID (PID)
SMARTnet for UCS Service with Drive Retention	UCS DR	UCSD7	24x7x4 Onsite	CON-UCSD7-B260M4
		UCSD5	8x5xNBD Onsite	CON-UCSD5-B260M4
SMARTnet for UCS HW ONLY+Drive Retention	UCS HW+DR	UCWD7	24x7x4 Onsite	CON-UCWD7-B260M4
		UCWD5	8x5xNBD Onsite	CON-UCWD5-B260M4

Table 22 Drive Retention Service Options for Partner Support Service

Service Description	Service Level GSP	Service Level	Product ID (PID)
Partner Support Service for UCS Drive Retention	PSJD6	8x5x4 Onsite	CON-PSJD6-B260M4
	PSJD7	24x7x4 Onsite	CON-PSJD7-B260M4

Table 23 Drive Retention Service Options for Partner Support Service (Hardware Only)

Service Description	Service Level GSP	Service Level	Product ID (PID)
Partner Support Service for UCS Drive Retention Hardware only	PSWD6	8x5x4 Onsite	CON-PSWD6-B260M4
	PSWD7	24x7x4 Onsite	CON-PSWD7-B260M4

For more service and support information, see the following URL:

http://www.cisco.com/en/US/services/ps2961/ps10312/Unified_Computing_Services_Overview.pdf

For a complete listing of available services for Cisco Unified Computing System, see this URL:

http://www.cisco.com/en/US/products/ps10312/serv_group_home.html

SUPPLEMENTAL MATERIAL

Motherboard

The top view of one of the two Blade Modules with the cover removed is shown in *Figure 5*. The B460 M4 consists of two Blade Modules connected by a Scalability Connector.

Figure 5 Top view of one of the two Blade Modules for B460 M4 E7 v4 (cover off)

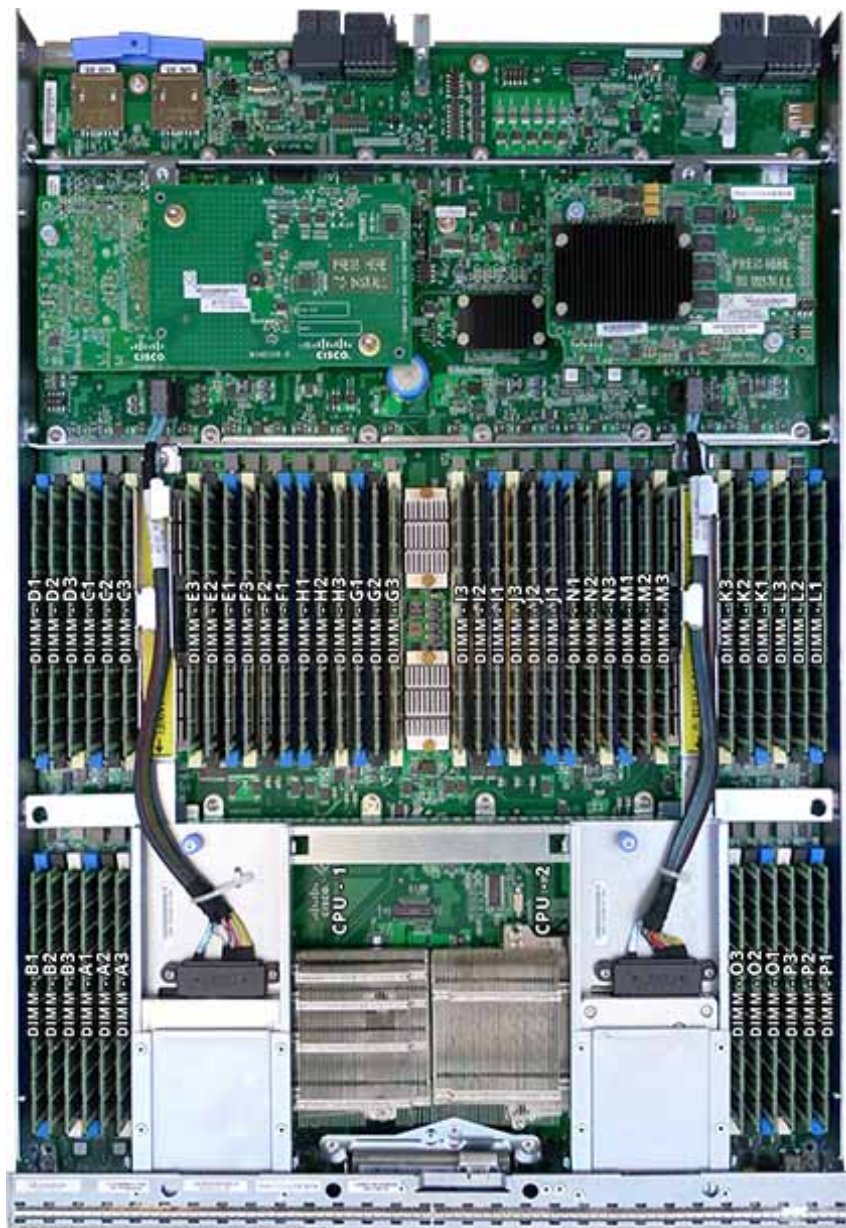

A drawing of the top view of one of the two Blade Modules for B460 M4 E7 v4 with the cover removed is shown in Figure [Figure 5](#).

Figure 6 Top view of one of the two Blade Modules for B460 M4 E7 v4 (cover off)

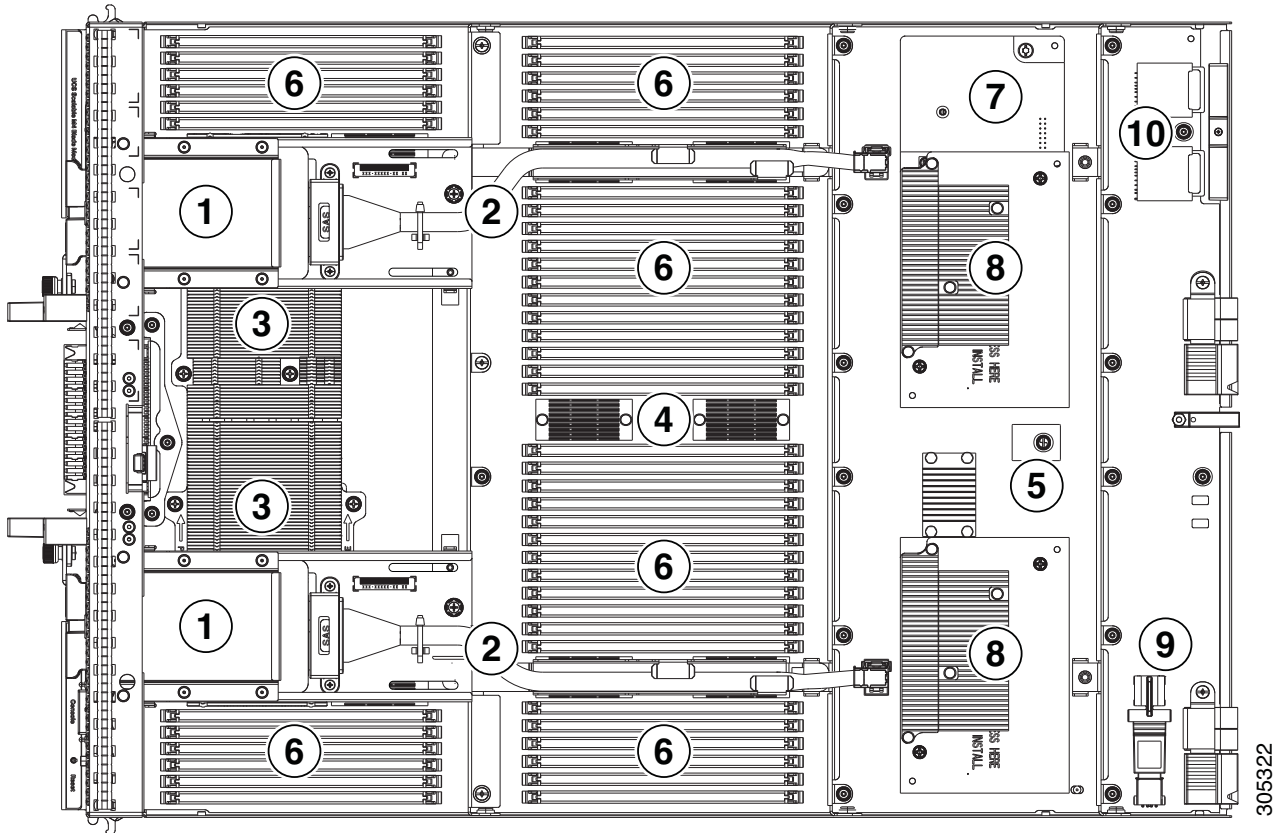

1	Drive bay	6	DIMM slots
2	SSD cable	7	mLOM card
3	Heat sinks covering CPU 1 on the left (facing the server) and CPU 2 on the right (facing the server)	8	Adapter cards
4	Memory buffers	9	IUSB memory
5	Trusted Platform Module (TPM)	10	SD card slots

DIMM and CPU Layout

The DIMM and CPU layout is shown in *Figure 7*.

Figure 7 DIMM and CPU Layout

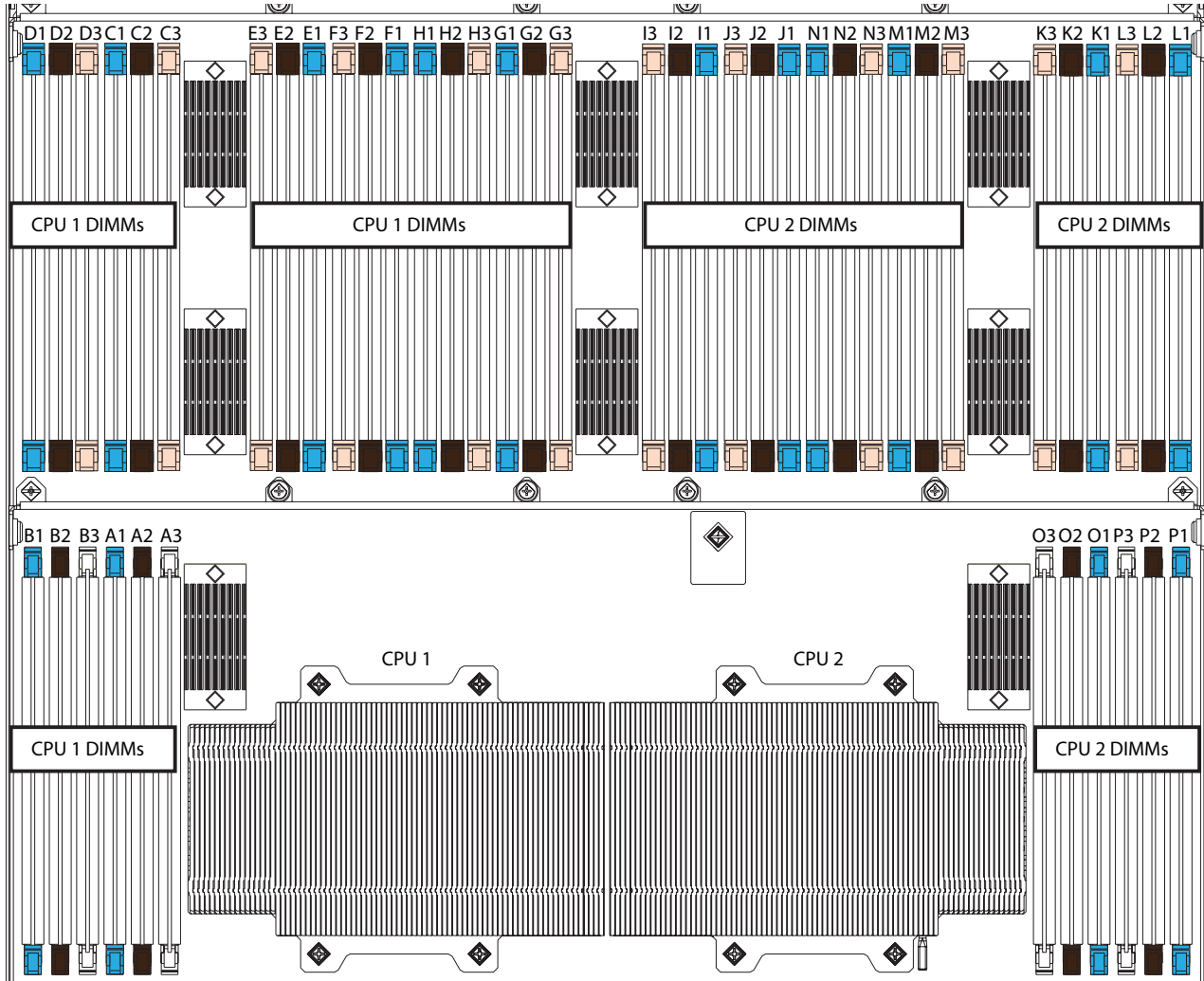

Each CPU controls four memory channels, and each memory channel controls two subchannels each through individual memory buffers placed around the motherboard (shown as black rectangles on *Figure 7*). Each subchannel controls 3 DIMMs as follows (refer also to *Figure 3* on page 13):

- CPU 1 subchannels A through H and DIMMs controlled:
 - A1 (blue DIMM slot), A2 (black DIMM slot), A3 (white DIMM slot)
 - B1 (blue DIMM slot), B2 (black DIMM slot), B3 (white DIMM slot)
 - C1 (blue DIMM slot), C2 (black DIMM slot), C3 (ivory DIMM slot)
 - D1 (blue DIMM slot), D2 (black DIMM slot), D3 (ivory DIMM slot)
 - E1 (blue DIMM slot), E2 (black DIMM slot), E3 (ivory DIMM slot)

- F1 (blue DIMM slot), F2 (black DIMM slot), F3 (ivory DIMM slot)
- G1 (blue DIMM slot), G2 (black DIMM slot), G3 (ivory DIMM slot)
- H1 (blue DIMM slot), H2 (black DIMM slot), H3 (ivory DIMM slot)
- CPU 2 subchannels I through P and DIMMs controlled:
 - I1 (blue DIMM slot), I2 (black DIMM slot), I3 (ivory DIMM slot)
 - J1 (blue DIMM slot), J2 (black DIMM slot), J3 (ivory DIMM slot)
 - K1 (blue DIMM slot), K2 (black DIMM slot), K3 (ivory DIMM slot)
 - L1 (blue DIMM slot), L2 (black DIMM slot), L3 (ivory DIMM slot)
 - M1 (blue DIMM slot), M2 (black DIMM slot), M3 (ivory DIMM slot)
 - N1 (blue DIMM slot), N2 (black DIMM slot), N3 (ivory DIMM slot)
 - O1 (blue DIMM slot), O2 (black DIMM slot), O3 (white DIMM slot)
 - P1 (blue DIMM slot), P2 (black DIMM slot), P3 (white DIMM slot)

Memory Population Recommendations

See [Table 5 on page 14](#) for DIMM population guidelines.

When considering the memory configuration of your server, you should observe the following:

- Performance degradation can result from unevenly populating DIMMs between CPUs.

Memory Mixing Guidelines

For the most part, it is recommended that all DIMMs that are installed be of the same type and size. See the following rules for mixing DIMMS.

- For 16 GB RDIMMs (UCS-MR-1X161RV-G):
Can only be mixed with 32 GB RDIMMs (UCS-MR-1X322RU-G). If 32 GB RDIMMs (UCS-MR-1X322RU-G) are mixed with 16 GB RDIMMs (UCS-MR-1X161RV-G), the total DIMM quantity must be multiples of 4. Sum cannot be greater than 96.
- For 32 GB RDIMMs (UCS-MR-1X322RU-G):
Can only be mixed with 16 GB RDIMMs (UCS-MR-1X161RV-G). If 16 GB RDIMMs (UCS-MR-1X161RV-G) are mixed with 32 GB RDIMMs (UCS-MR-1X322RU-G), the total DIMM quantity must be multiples of 4. Sum cannot be greater than 96.
- For 32 GB LRDIMMs (UCS-ML-1X324RU-G):
Can only be mixed with 64 GB LRDIMMs (UCS-ML-1X644RU-G). If 64 GB LRDIMMs (UCS-ML-1X644RU-G) are mixed with 32 GB LRDIMMs (UCS-ML-1X324RU-G), the total DIMM quantity must be multiples of 4. Sum cannot be greater than 96.
- For 64 GB LRDIMMs (UCS-ML-1X644RU-G):
Can only be mixed with 32 GB LRDIMMs (UCS-ML-1X324RU-G). If 64 GB LRDIMMs (UCS-ML-1X644RU-G) are mixed with 32 GB LRDIMMs (UCS-ML-1X324RU-G), the total DIMM quantity must be multiples of 4. Sum cannot be greater than 96.

Upgrade and Servicing-Related Parts

This section lists the upgrade and servicing-related parts you may need during the life of your server. Some of these parts are configured with every server or with every UCS 5108 blade server chassis, and some may be ordered when needed or may be ordered and kept on hand as spares for future use. See [Table 24](#).

Table 24 Upgrade and Servicing-related Parts for UCS B460 M4 E7 v4 Server

Spare Product ID (PID)	Description
N20-BBLKD-7MM=	UCS 7 mm SSD Blanking Panel ¹
UCSB-HS-01-EX=	CPU Heat Sink for UCS B260 M4 and B460 M4 ¹
N20-BKVM=	KVM local IO cable for UCS servers console port ²
UCS-CPU-EP-PNP=	Pick n place CPU tools for M4 CPUs ³
UCS-CPU-GREASE3=	Thermal grease for M4/EX heat sink seal ³
UCSX-HSCK=	UCS Processor Heat Sink Cleaning Kit (when replacing a CPU) ³
UCS-SD-32G-S=4	32 GB SD card module for UCS servers
UCS-SD-64G-S=5	64GB SD Card for UCS Servers
UCS-USBFLSHB-16GB=	16 GB Flash USB drive ⁵

Notes . . .

1. This part is included/configured with your UCS server (in some cases, as determined by the configuration of your server).
2. This part is included/configured with the UCS 5108 blade server chassis.
3. This part is included with the purchase of each optional or spare CPU processor kit.
4. Only half the capacity of the 32 GB SD card is available in this server. Must be installed only in Master (bottom) blade module.
5. Must be installed only in Master (bottom) blade module.

Drive and Blade Server Blanking Panels

An SSD blanking panel (N20-BBLKD-7MM=) must be installed if you remove an SSD from the UCS server. These panels are required to maintain system temperatures at safe operating levels, and to keep dust away from system components.

Replacing a CPU (with CPU heat sink)

Instructions for replacing a CPU and heat sink can be found at the following link:

http://www.cisco.com/c/en/us/td/docs/unified_computing/ucs/hw/blade-servers/B460M4.html

CPU Removal and Installation (“pick n place”) Tool Set

The Pick n Place tool set is used to install a CPU in its socket without damage. It must be used each time a CPU is installed in the server.

Instructions for using this tool set are found at the following link:

http://www.cisco.com/c/en/us/td/docs/unified_computing/ucs/hw/blade-servers/B460M4.html



NOTE: When you purchase a spare CPU, the Pick n Place Toolkit is included.

Thermal Grease (with syringe applicator) for CPU to Heatsink Seal

Thermal grease must be applied to the top of the CPU where it comes in contact with the heat sink. Instructions for applying thermal grease are found at:

http://www.cisco.com/c/en/us/td/docs/unified_computing/ucs/hw/blade-servers/B460M4.html



CAUTION:
DO NOT use thermal grease available for purchase at any commercial electronics store. If these instructions are not followed, the CPU may overheat and be destroyed.



NOTE: When you purchase a spare CPU, the thermal grease with syringe applicator is included.

CPU Heat Sink Cleaning Kit

The cleaning kit is used to remove the existing thermal compound from the bottom of the heat sink during a CPU replacement process. Instructions for cleaning are found at the following link:

http://www.cisco.com/c/en/us/td/docs/unified_computing/ucs/hw/blade-servers/B460M4.html



NOTE: When you purchase a spare CPU, the CPU cleaning kit is included.

Network Connectivity

This section shows how the supported adapter card configurations for each one of the two Blade Modules connecting to the Fabric Extender modules in the 5108 blade server chassis. Recall that the B460 M4 E7 v4 consists of two cross-connected Scalable M4 Blade Modules.

There are three configurable adapter slots on each one of the two Blade Modules for B460 M4 E7 v4. For each Blade Module, one slot supports only the VIC 1340/ adapter, and two additional slots can accommodate other Cisco adapters. [Table 10 on page 23](#) shows supported adapter configurations. You must install at least one VIC or CNA in one of the six adapter slots.

“Adapter 1,” “Adapter 2,” and “Adapter 3” refer to the UCSM naming convention for the adapter slots (this document uses the UCSM naming convention). In the server BIOS and on the motherboard, the corresponding slots are labeled as “mLOM,” “Mezz 1,” and “Mezz 2,” respectively. See [Table 25](#).

Table 25 Adapter Slot Naming and Bandwidth

B460 M4 E7 v4 Blade Module	Server BIOS and Motherboard Slot Naming	UCSM Slot Naming	Available Bandwidth
“Slave” Blade Module (top)	mLOM (VIC 1340 only)	Adapter 1	20 Gbps per Fabric Extender
	Mezz1	Adapter 2	20 Gbps per Fabric Extender
	Mezz2	Adapter 3	40 Gbps per Fabric Extender
“Master” Blade Module (bottom)	mLOM (VIC 1340 only)	Adapter 1	20 Gbps per Fabric Extender
	Mezz1	Adapter 2	20 Gbps per Fabric Extender
	Mezz2	Adapter 3	40 Gbps per Fabric Extender

Total bandwidth is a function of the Fabric Extender, the adapter, and the adapter slot, as shown in [Table 26](#) and [Table 27](#).

Table 26 Maximum Bandwidth Using Dual Fabric Extenders (FEXs)

FEX Model	Maximum Bandwidth Using Dual FEXs
2304	160 Gb
2208XP	160 Gb
2204XP	160 Gb

Table 27 Maximum Bandwidth for Each of the Three Adapter Slots

Adapter Slot	Maximum Bandwidth Using Dual FEXs
VIC 1340 (Adapter 1) slot	40 Gb
Adapter 2 Slot	40 Gb
Adapter 3 Slot	80 Gb

Figure 8 shows the configuration for maximum bandwidth for each Blade Module in the Server, where the following ports are routed to Fabric Extender Modules A and B inside the 5108 blade server chassis:

- Two 2 x 10G KR ports from the VIC 1340 adapter
- Two 2 x 10G KR ports from the Port Expander
- Two 4 x 10G KR ports from the VIC 1380 adapter

The resulting aggregate bandwidth is 160 Gb (80 Gb to each Fabric Extender).

Figure 8 Connections from Each Blade Module in the Server to the Fabric Extenders

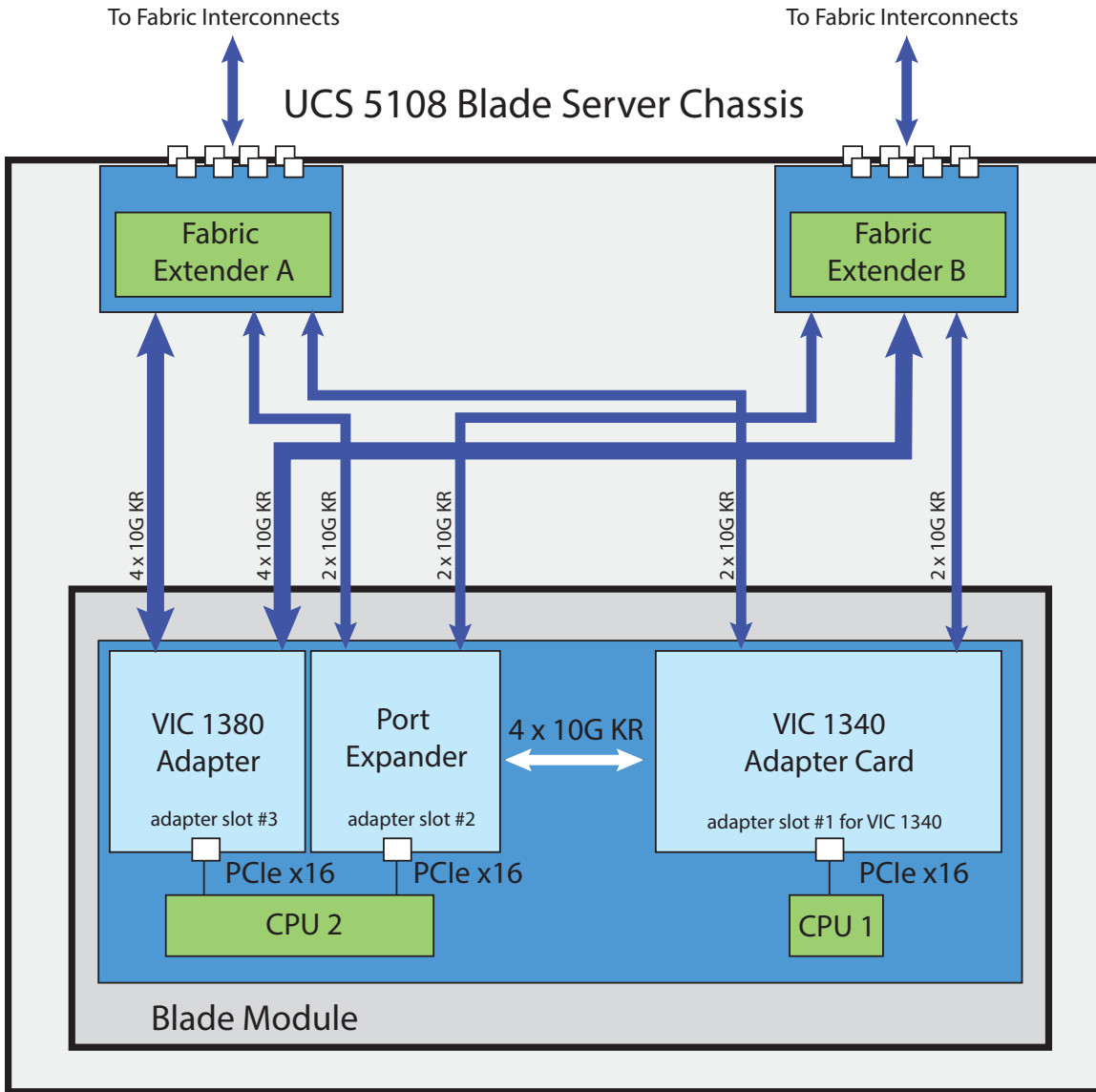

VIC 1340 and Port Expander

Adapter slot 1 is dedicated to the VIC 1340 adapter, and no other adapter card can be installed in this slot. There are two groups of four ports on the VIC 1340:

- Two ports of the first group and two ports of the second group are wired through the UCS 5108 Blade Server chassis to Fabric Extender A and Fabric Extender B.
- The other two ports of each group are wired to adapter slot 2. The VIC 1340 adapter senses the type of adapter installed in adapter slot 2. If a Port Expander is installed in adapter slot 2, the four 10G KR ports between the adapters are used for port expansion; otherwise they are unused.

With the Port Expander installed, there are up to eight (depending on the Fabric Extender installed) 10 Gb network interfaces, as represented in [Figure 9](#).

Figure 9 VIC 1340 Connectivity

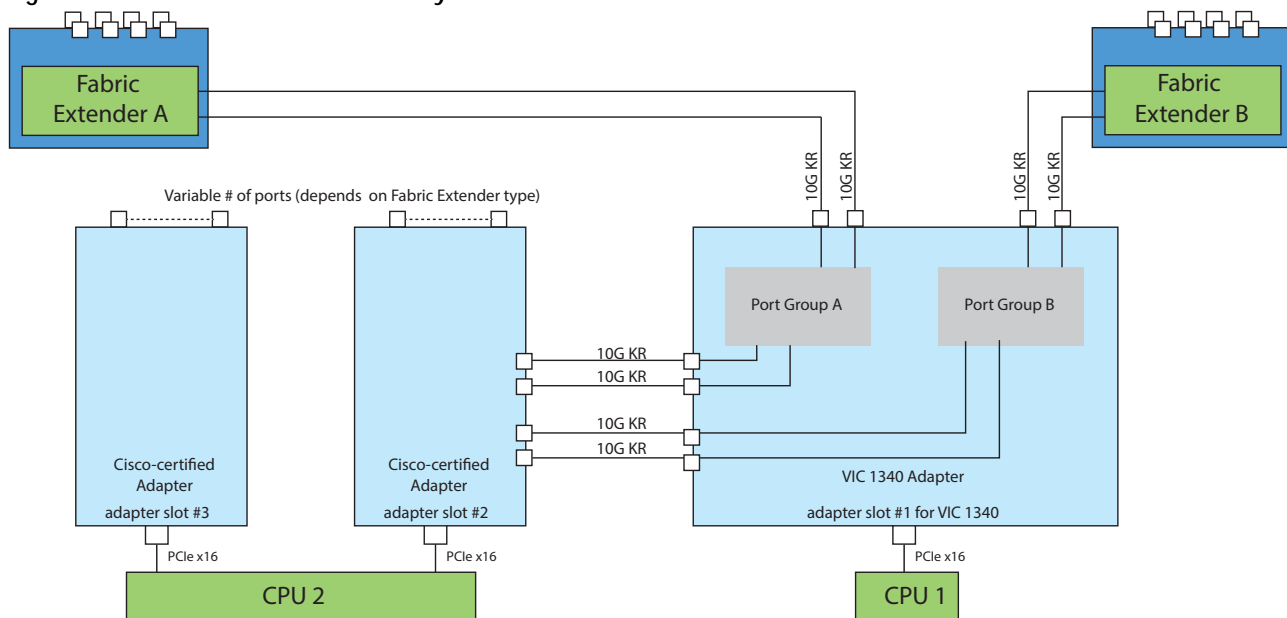

Connectivity Using the Cisco UCS 2304/2208XP/2204XP Fabric Extender

The connectivity options for each of the two Blade Modules shown in *Figure 10* through *Figure 19* are summarized in *Table 28*.

Table 28 Supported Adapter¹ Combinations Using the 2208XP/2204XP FEX

Adapter Slot 1	Adapter Slot 2	Adapter Slot 3	Total Available Bandwidth
			2 x 2304 2 x 2208XP/ 2 x 2204XP
VIC 1340	Port Expander Card	VIC 1380	160/160/80 Gb <i>Figure 10 on page 49</i>
VIC 1340	Cisco UCS Storage Accelerator	VIC 1380	160/120/60 Gb <i>Figure 11 on page 49</i>
VIC 1340	Not populated	VIC 1380	120/120/60Gb <i>Figure 12 on page 50</i>
Not populated	Cisco UCS Storage Accelerator	VIC 1380	80/80/40 Gb <i>Figure 13 on page 50</i>
Not populated	Not populated	VIC 1380	80/80/40 Gb <i>Figure 14 on page 51</i>
VIC 1340	Port Expander Card	Cisco UCS Storage Accelerator	80/80/40 Gb <i>Figure 15 on page 51</i>
VIC 1340	Port Expander Card	Not populated	80/80/40 Gb <i>Figure 16 on page 52</i>
VIC 1340	Cisco UCS Storage Accelerator	Cisco UCS Storage Accelerator	80/40/20 Gb <i>Figure 17 on page 52</i>
VIC 1340	Cisco UCS Storage Accelerator	Not populated	80/40/20 Gb <i>Figure 18 on page 53</i>
VIC 1340	Not populated	Not populated	40/40/20 Gb <i>Figure 19 on page 53</i>

Notes . . .

1. In the server BIOS and on the motherboard, “Adapter 1,” “Adapter 2,” and “Adapter 3” are labeled as “mLOM,” “Mezz 1,” and “Mezz 2,” respectively

In *Figure 10*, two ports from the VIC 1340 are channelled to Fabric Extender A and two are channelled to Fabric Extender B. The Port Expander Card installed in adapter slot 2 acts as a pass-through device, channeling two ports to each of the Fabric Extenders. In addition, the VIC 1380 channels four ports to each Fabric Extender. The result is 80 Gb of bandwidth to each Fabric Extender.

Figure 10 VIC 1340, Port Expander in adapter slot 2, and VIC 1380 in adapter slot 3

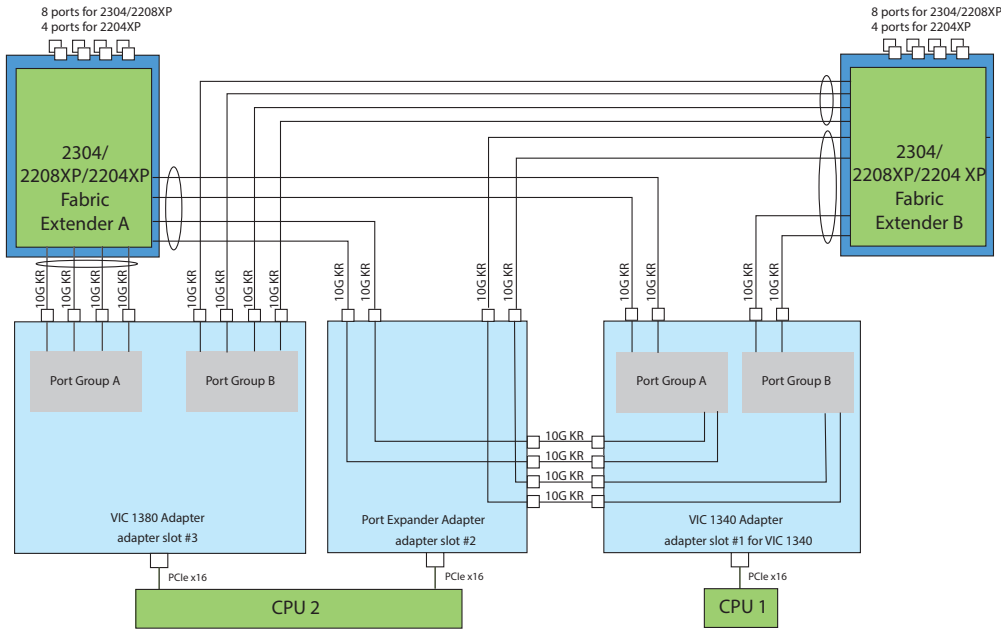

In *Figure 11*, two ports from the VIC 1340 are channelled to Fabric Extender A and two are channelled to Fabric Extender B. A Cisco UCS Storage Accelerator adapter is installed in slot 2, but provides no network connectivity. The VIC 1380 installed in adapter slot 3 channels four ports to each of the Fabric Extenders. The result is 80 Gb of bandwidth to each Fabric Extender.

Figure 11 VIC 1340, Cisco UCS SA in adapter slot 2, and VIC 1380 in adapter slot 3

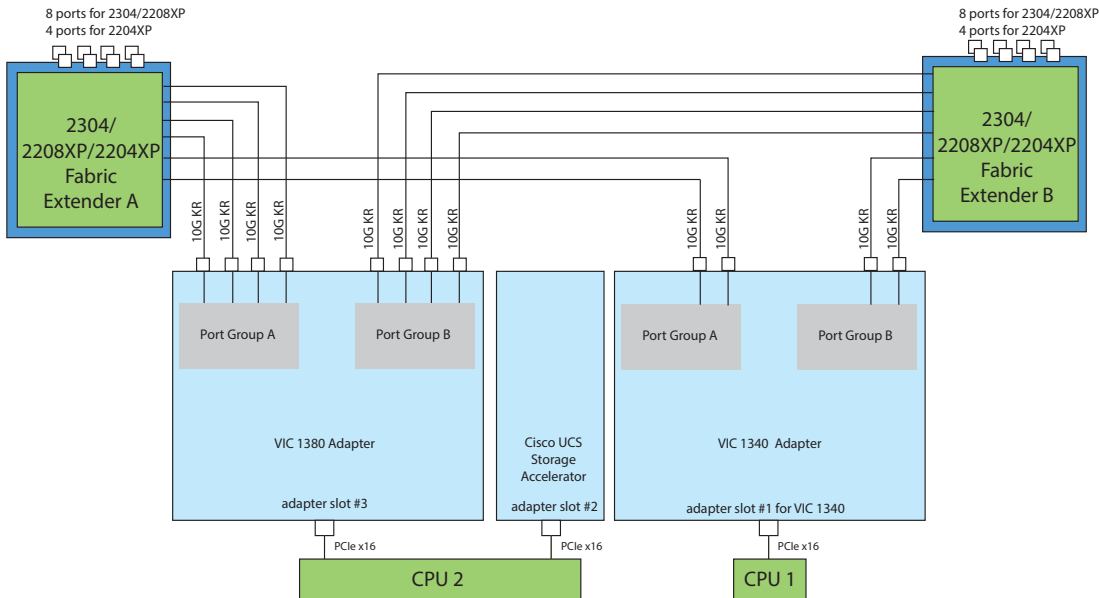

In *Figure 12*, two ports from the VIC 1340 are channelled to Fabric Extender A and two are channelled to Fabric Extender B. Adapter slot 2 is empty. The VIC 1380 installed in adapter slot 3 channels four ports to each of the Fabric Extenders. The result is 60 Gb of bandwidth to each Fabric Extender.

Figure 12 VIC 1340 and VIC 1380 (adapter slot 2 empty)

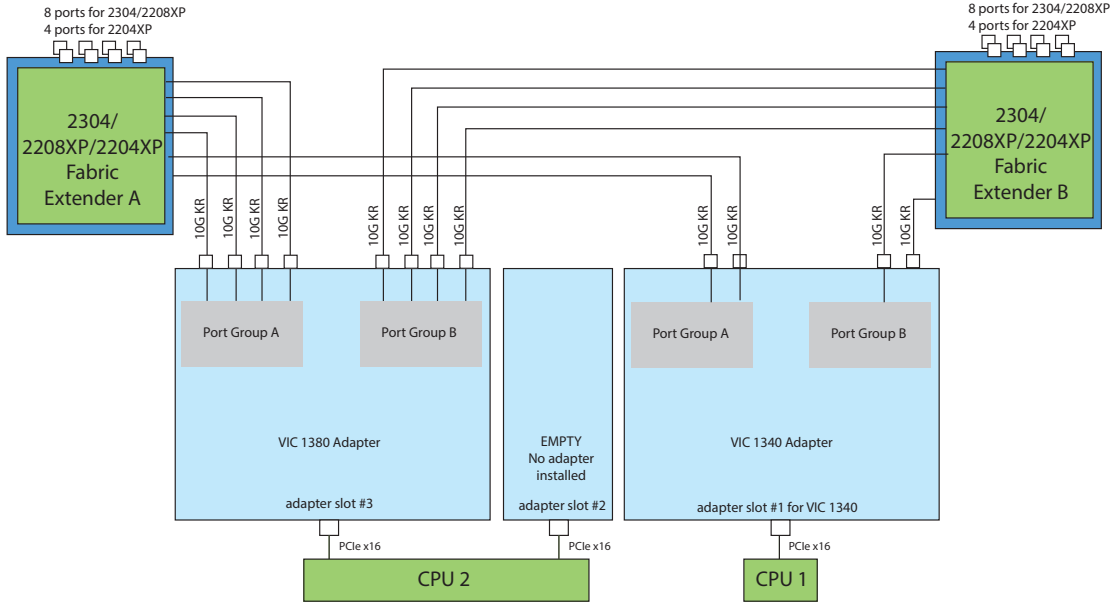

In *Figure 13*, no VIC 1340 is installed. A Cisco UCS Storage Accelerator adapter is installed in slot 2, but provides no network connectivity. The VIC 1380 installed in adapter slot 3 channels four ports to each of the Fabric Extenders. The result is 40 Gb of bandwidth to each Fabric Extender.

Figure 13 No VIC 1340 installed, UCS Storage Accelerator in slot 2 and VIC 1380 in slot 3

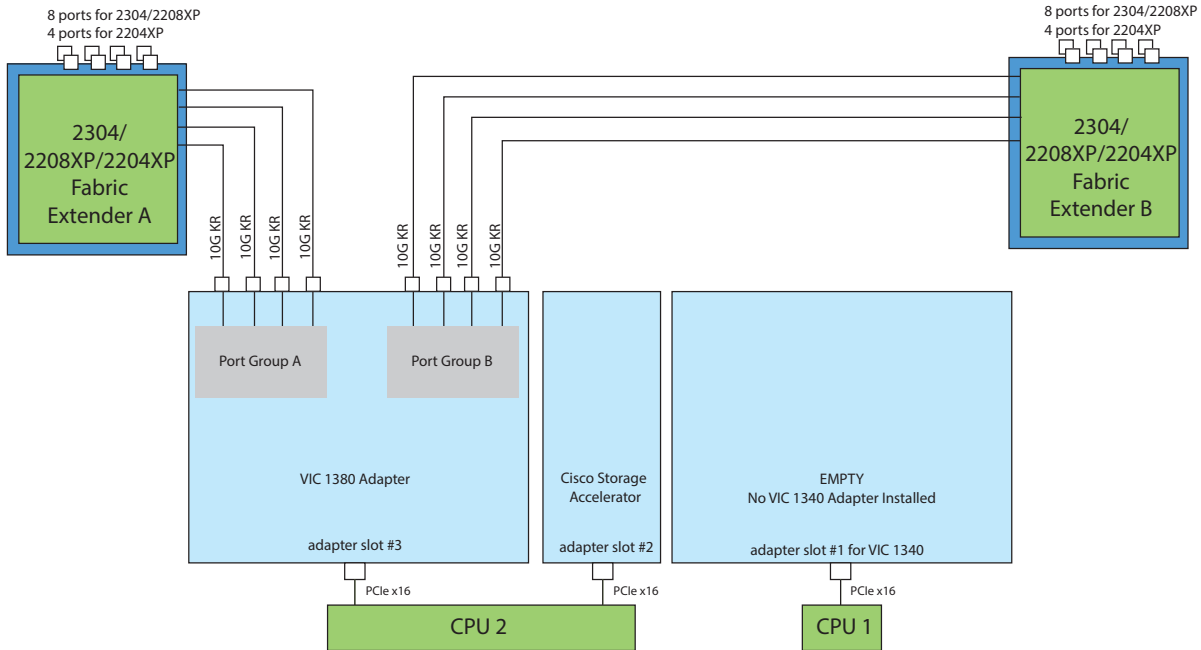

In *Figure 14*, no VIC 1340 is installed. Adapter 2 slot is also not occupied. The VIC 1380 installed in adapter slot 3 channels four ports to each of the Fabric Extenders. The result is 40 Gb of bandwidth to each Fabric Extender.

Figure 14 No VIC 1340 installed, no adapter installed in slot 2, and VIC 1380 in slot 3

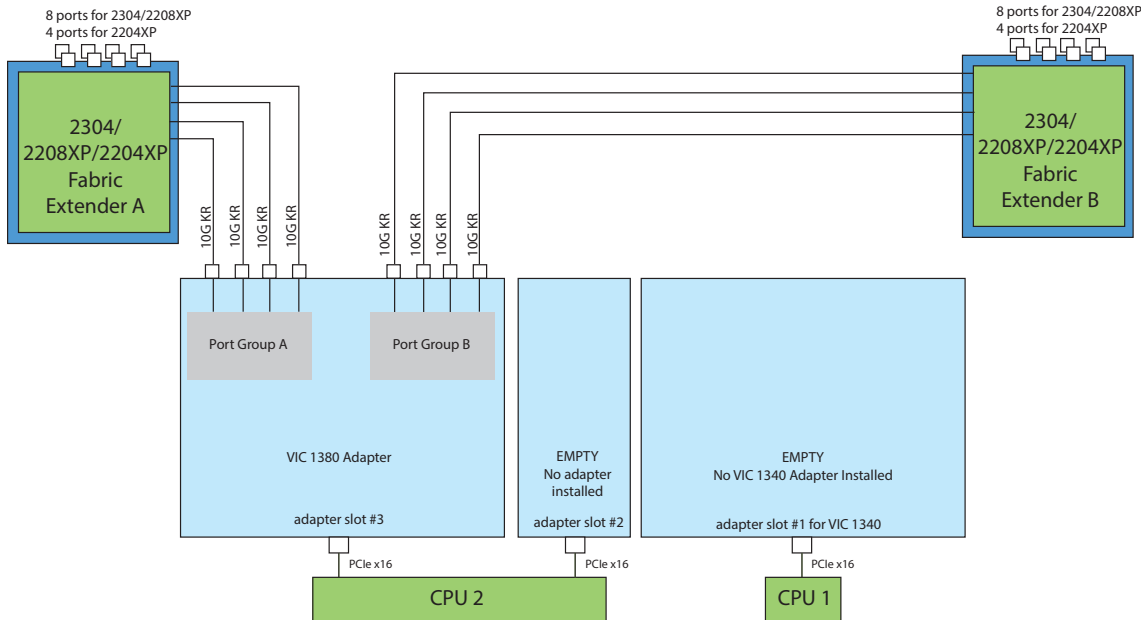

In *Figure 15*, two ports from the VIC 1340 are channeled to Fabric Extender A and two are channeled to Fabric Extender B. The Port Expander Card installed in adapter slot 2 acts as a pass-through device, channeling two ports to each of the Fabric Extenders. A Cisco UCS storage accelerator is installed in slot 3, but provides no network connectivity. The result is 40 Gb of bandwidth to each Fabric Extender.

Figure 15 VIC 1340 and Port Expander in Adapter Slot 2 with UCS storage accelerator in slot 3

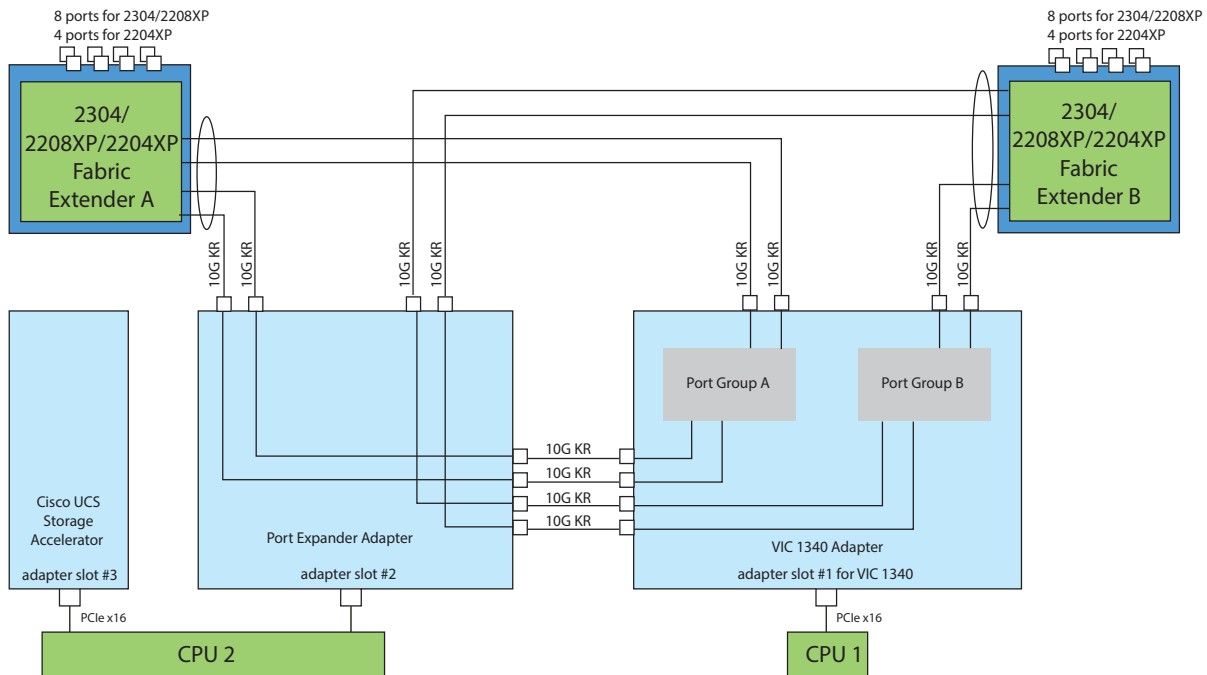

In *Figure 16*, two ports from the VIC 1340 are channeled to Fabric Extender A and two are channeled to Fabric Extender B. The Port Expander Card installed in adapter slot 2 acts as a pass-through device, channeling two ports to each of the Fabric Extenders. Adapter slot 3 is empty. The result is 40 Gb of bandwidth to each Fabric Extender.

Figure 16 VIC 1340 and Port Expander in Adapter Slot 2 (adapter slot 3 empty)

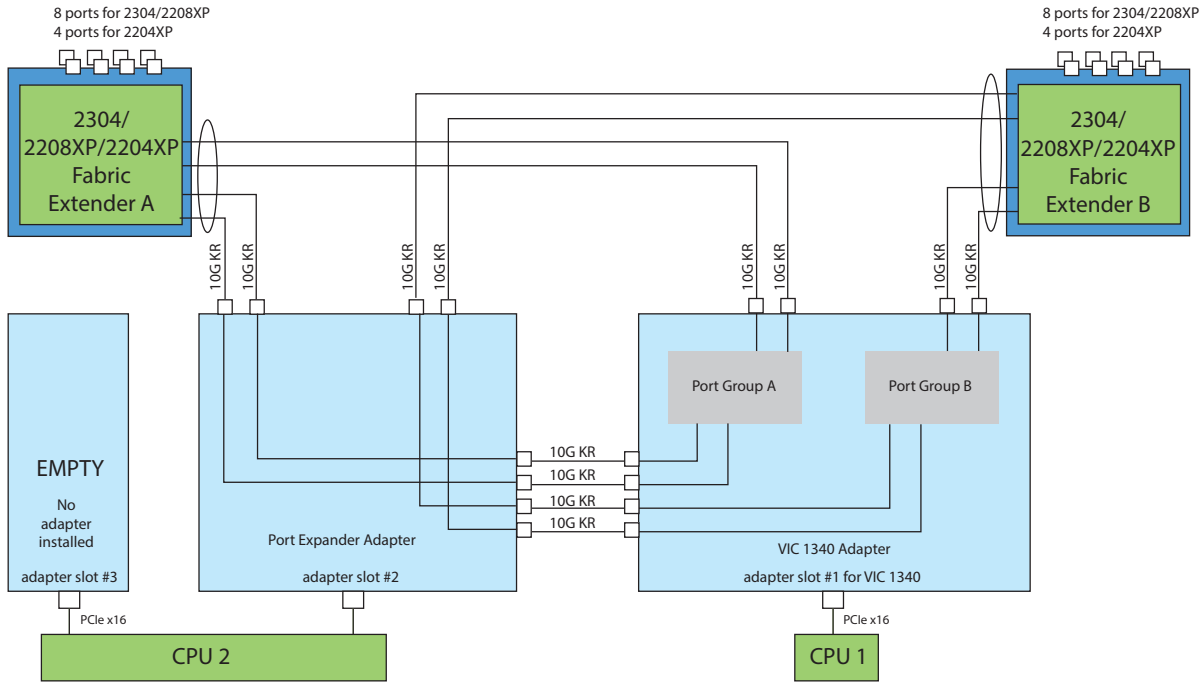

In *Figure 17*, two ports from the VIC 1340 adapter are channeled to Fabric Extender A and two are channeled to Fabric Extender B. UCS storage accelerators are installed in adapter slots 2 and 3, but provide no network connectivity. The result is 20 Gb of bandwidth to each Fabric Extender.

Figure 17 VIC 1340 with UCS storage accelerators installed in adapter slots 2 and 3

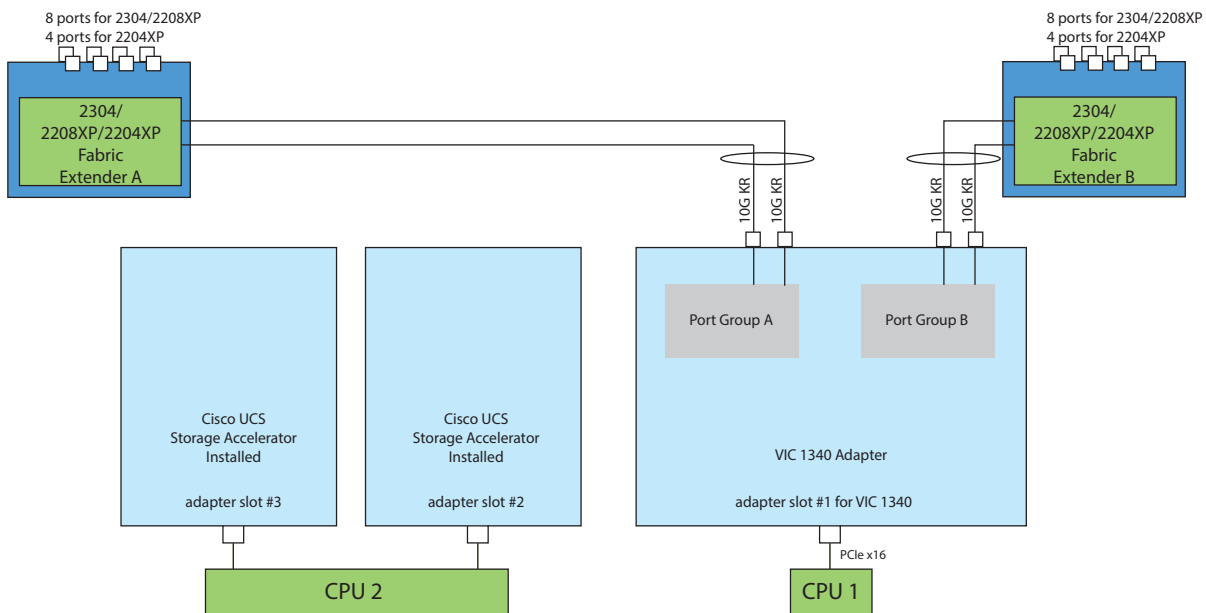

In *Figure 18*, two ports from the VIC 1340 adapter are channeled to Fabric Extender A and two are channeled to Fabric Extender B. A UCS storage accelerator is installed in adapter slot 2 but provides no network connectivity and slot 3 is empty. The result is 20 Gb of bandwidth to each Fabric Extender.

Figure 18 VIC 1340 with UCS storage accelerator installed in adapter slot 2 and slot 3 empty

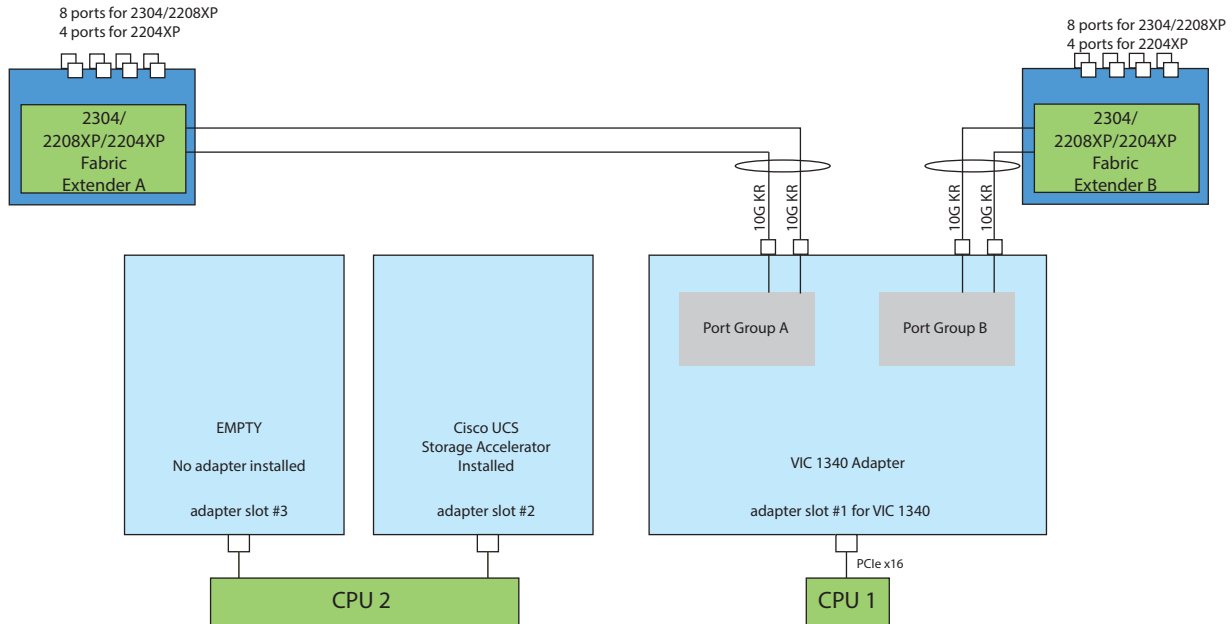

In *Figure 19*, two ports from the VIC 1340 adapter are channeled to Fabric Extender A and two are channeled to Fabric Extender B. Adapter slots 2 and 3 are empty. The result is 20 Gb of bandwidth to each Fabric Extender.

Figure 19 VIC 1340 (adapter slots 2 and 3 empty)

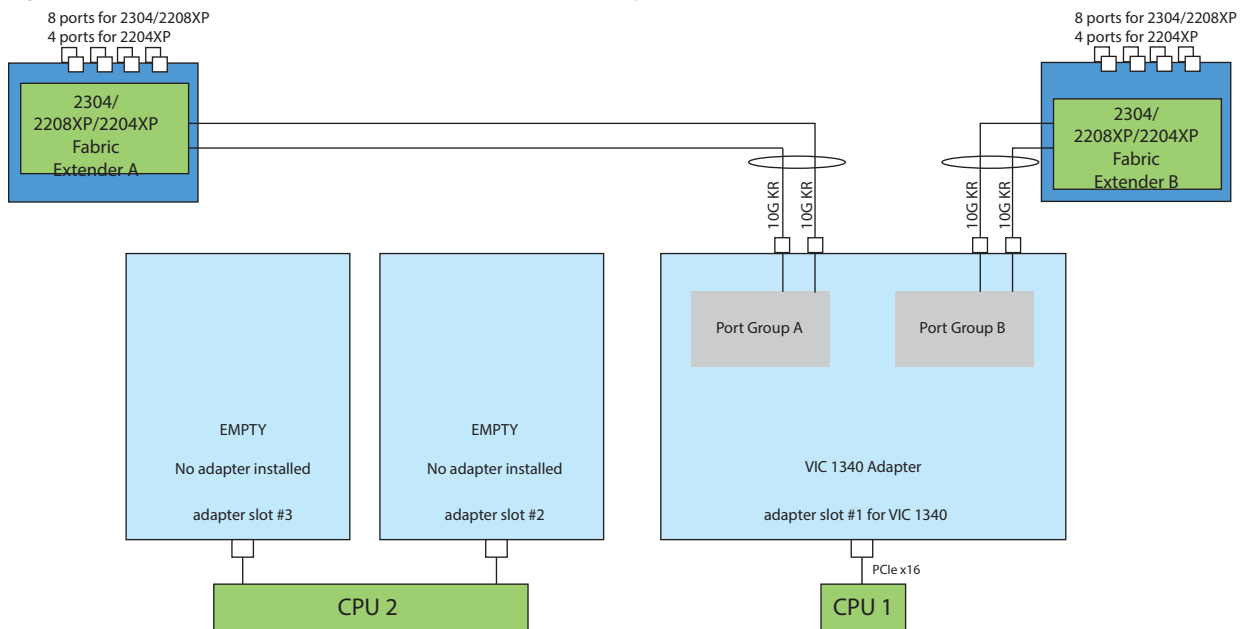

TECHNICAL SPECIFICATIONS

Dimensions and Weight

Table 29 UCS B460 M4 E7 v4 Dimensions and Weight¹

Parameter	Value
Height	4.04 in. (102.6 mm)
Width	17.20 in. (436.9 mm)
Depth	25.5 in. (647.7 mm)
Weight	61.8 lbs (28.0 kg)*

Notes . . .

1. The system weight given here is an estimate for a fully configured system and will vary depending on the number of CPUs, memory DIMMs, and other optional items.

Power Specifications

For configuration-specific power specifications, use the Cisco UCS Power Calculator at:

<http://ucspowercalc.cisco.com>.

Discontinued EOL Products

Below is the list of parts were previously available for this product and are no longer sold. Please refer to the EOL Bulletin Links via the [Table 30](#) below to determine if still supported.

Table 30 EOL Products

EOS option PID	Description	EOL bulletin link
MEMORY		
UCS-ML-1X324RU-G	32 GB DDR4-2133/2400-MHz LRDIMM/4R/x4/1.2v 1.2 4	https://www.cisco.com/c/en/us/products/collateral/servers-unified-computing/ucs-c-series-rack-servers/eos-eol-notice-c51-741234.html
UCS-ML-1X644RU-G	64 GB DDR4-2133/2400-MHz LRDIMM/4R/x4/1.2v 1.2 4	https://www.cisco.com/c/en/us/products/collateral/servers-unified-computing/ucs-c-series-rack-servers/eos-eol-notice-c51-741234.html
UCS-MR-1X161RV-G	16GB DDR4-2133MHz/2400-MHz RDIMM/single rank/x4/1.2v	https://www.cisco.com/c/en/us/products/collateral/servers-unified-computing/ucs-c-series-rack-servers/eos-eol-notice-c51-741234.html
UCS-MR-1X322RU-G	32 GB DDR4-2133/2400-MHz RDIMM/2R/x4/1.2v 1.2 2	https://www.cisco.com/c/en/us/products/collateral/servers-unified-computing/ucs-c-series-rack-servers/eos-eol-notice-c51-741234.html
UCS-MR-1X322RUG-S	32GB DDR4-2133-MHz RDIMM/PC4-17000/dual rank/x4/1.2v Samsung	https://www.cisco.com/c/en/us/products/collateral/servers-unified-computing/ucs-c-series-rack-servers/eos-eol-notice-c51-741234.html
DRIVES		
Enterprise Performance		
UCS-SD480GB7M-EP	480GB 7mm Enterprise Performance SATA SSD	https://www.cisco.com/c/en/us/products/collateral/servers-unified-computing/ucs-c-series-rack-servers/eos-eol-notice-c51-741234.html
Enterprise Value		
UCS-SD120GB7M-EV	120 GB 7mm Enterprise Value SATA SSD	https://www.cisco.com/c/en/us/products/collateral/servers-unified-computing/ucs-c-series-rack-servers/eos-eol-notice-c51-741234.html
UCS-SD16TB7M-EV	1.6TB 7mm Enterprise Value SATA SSD	https://www.cisco.com/c/en/us/products/collateral/servers-unified-computing/ucs-c-series-rack-servers/eos-eol-notice-c51-741234.html



Americas Headquarters
Cisco Systems, Inc.
San Jose, CA

Asia Pacific Headquarters
Cisco Systems (USA) Pte. Ltd.
Singapore

Europe Headquarters
Cisco Systems International BV Amsterdam,
The Netherlands

Cisco has more than 200 offices worldwide. Addresses, phone numbers, and fax numbers are listed on the Cisco Website at www.cisco.com/go/offices.

Cisco and the Cisco Logo are trademarks of Cisco Systems, Inc. and/or its affiliates in the U.S. and other countries. A listing of Cisco's trademarks can be found at www.cisco.com/go/trademarks. Third party trademarks mentioned are the property of their respective owners. The use of the word partner does not imply a partnership relationship between Cisco and any other company. (1005R)