

Cisco Compute Hyperconverged with Nutanix XE130c M8 Edge Server



CISCO SYSTEMS
170 WEST TASMAN DR.
SAN JOSE, CA, 95134
WWW.CISCO.COM

PUBLICATION HISTORY

REV A.01 APRIL4 , 2026

OVERVIEW	3
DETAILED VIEWS	4
Front View	4
SERVER STANDARD CAPABILITIES and FEATURES	6
CONFIGURING THE CISCO COMPUTE HYPERCONVERGED WITH NUTANIX XE130C M8 EDGE SERVER	8
STEP 1 CHOOSE BASE SERVER SKU	9
STEP 2 CHOOSE AI INTENT (REQUIRED)	10
STEP 3 SELECT MEMORY (REQUIRED)	11
Memory configurations and mixing rules	14
STEP 4 CHOOSE GPUs (OPTIONAL)	15
STEP 5 SELECT M.2 BOOT RAID CONTROLLER and SATA SSDs (REQUIRED)	16
STEP 6 SELECT RISERS (REQUIRED)	17
STEP 7 SELECT DRIVES (REQUIRED)	18
STEP 8 CHOOSE OPTIONAL TRUSTED PLATFORM MODULE	19
STEP 9 SELECT GUEST VM OPERATING SYSTEM LICENSES (Optional)	20
STEP 10 SELECT HYPERVISOR	21
STEP 11 SELECT NUTANIX SOFTWARE AND NUTANIX PROFESSIONAL SERVICES	22
Top Level Nutanix Software And Professional Services PIDs	23
Nutanix Software And Professional Services PID Decoder	25
Nutanix Software PIDs and Description	26
Nutanix software limited orderability	62
Professional Services PIDs and Description	64
Nutanix Support:	76
Software With Professional Services PID Mapping	77
	84
SUPPLEMENT MATERIAL	86
System Board	86
TECHNICAL SPECIFICATIONS	87
Dimensions and Weight	87
Environmental Specifications	87
System Requirements	87
Power Specifications	88

OVERVIEW

Cisco Compute Hyperconverged with Nutanix accelerates and simplifies the delivery of infrastructure and applications, at a global scale, through best-in-class cloud-operating models, industry-leading flexibility, and enhanced support and resiliency capabilities so you can power your hybrid multicloud future with the industry's most complete hyperconverged solution.

Cisco Unified Edge brings together computing, storage, routing, switching, and security into a single configurable solution to help IT organizations simplify the deployment, operations, and lifecycle management of edge infrastructure at global scale. Cisco Unified Edge is a fully integrated, edge-optimized, AI-ready, and SaaS managed platform, engineered to deliver a superior user experience with unprecedented visibility, consistency, and control for a host of edge use cases.

Cisco Unified Edge is a modular edge platform, with a 3RU, short-depth, multi-mountable chassis with features to operate in extended temperature range (5°C to 45°C), maintain a quiet acoustic profile (40s dBA at 25°C and 20% PWM), and offer protection against high particulate environments, allowing deployments in a wide range of physical spaces.

The Cisco Compute Hyperconverged with Nutanix XE130c M8 Edge Server is a family of 1RU, half-width server; up to five Cisco Compute Hyperconverged with Nutanix XE130c M8 Edge Server can be housed inside a Cisco UCS XE9305 chassis. It delivers enterprise class, performance, versatility and density but in a compact edge-optimized form factor. Powered by the Intel® Xeon® 6 SoC processors with Performance-Cores and available in two riser configurations (“Storage-Optimized” and “IO-Optimized”), the Cisco Compute Hyperconverged with Nutanix XE130c M8 Edge Server offers industry-leading adaptability at the edge, supporting a variety of PCIe accelerators (such as GPUs) and adaptors, and integrated networking with two front-panel 1/10 Gbps NICs and two rear-facing 25 Gbps NICs connecting to the in-chassis network mid-plane. This versatility enables the Cisco Compute Hyperconverged with Nutanix XE130c M8 Edge Server as a building block in the deployment of a wide range of workloads including bare-metal servers, virtualization, containers, and AI/ML.

NOTE: All options listed in the spec Sheet are compatible with Intersight Managed Mode configurations. For firmware requirements for all components in Intersight Managed Mode [see Supported Systems](#).

Figure 1 Front View

Four Drive Configuration



Three Drive Configuration



DETAILED VIEWS

Front View

Figure 2 & Figure 3 is a front view of the Cisco Compute Hyperconverged with Nutanix XE130c M8 Edge Server.

Figure 2 Front View

When Selected Storage Riser with four drive configuration

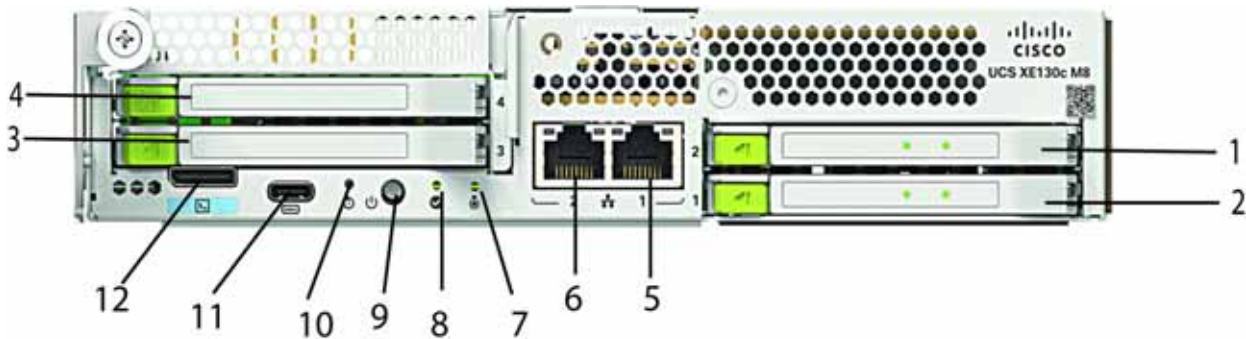

1	Drive Bay 1 (shown populated)	7	Status LED
2	Drive Bay 2 (shown populated)	8	Network activity LED
3	Drive Bay 3 (shown populated)	9	Power button/LED
4	Drive Bay 3 (shown populated)	10	Locate button/LED
5	RJ45 Connector	11	USB-C console
6	RJ45 Connector	12	OCuLink console port ¹

Notes:

1. An adapter cable (PID UCSX-C-DEBUGCBL) is required to connect the OCuLink port to the transition serial USB and video (SUV) octopus cable.

Figure 3 Front View

When Selected Storage Riser with three drive configuration

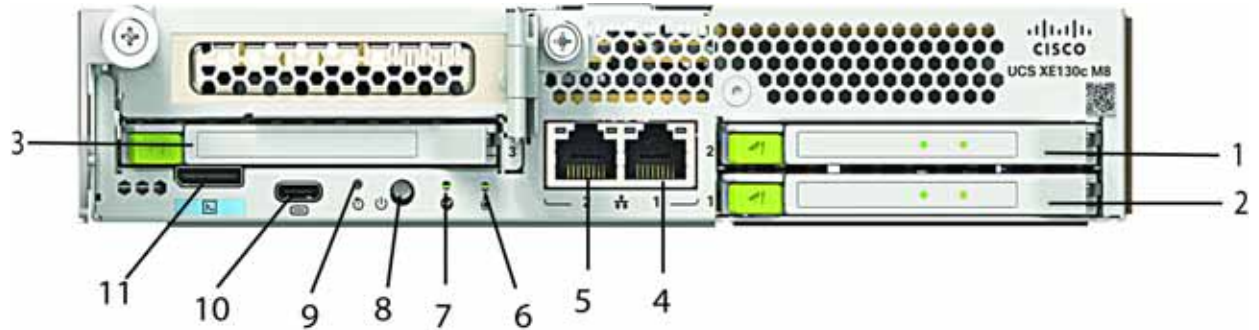

1	Drive Bay 1 (shown populated)	7	Network activity LED
2	Drive Bay 2 (shown populated)	8	Power button/LED
3	Drive Bay 3 (shown populated)	9	Locate button/LED
4	RJ45 Connector	10	USB-C console
5	RJ45 Connector	11	OCuLink console port ¹
6	Status LED	-	-

Notes:

1. An adapter cable (PID UCSX-C-DEBUGCBL) is required to connect the OcuLink port to the transition serial USB and video (SUV) octopus cable.

SERVER STANDARD CAPABILITIES and FEATURES

Table 1 lists the capabilities and features of the base Cisco Compute Hyperconverged with Nutanix XE130c M8 Edge Server. Details about how to configure the server for a listed feature or capability (for example, GPUs number of processors, drives, or amount of memory) are provided in [CONFIGURING THE CISCO COMPUTE HYPERCONVERGED WITH NUTANIX XE130C M8 EDGE SERVER](#) on page 8

Table 1 Capabilities and Features

Capability/Feature	Description
Form Factor and Chassis	<ul style="list-style-type: none"> ■ 1RU-high and half-width server. ■ The Cisco Compute Hyperconverged with Nutanix XE130c M8 Edge Server mounts in a Cisco UCS XE9305 chassis.
CPU	One Intel® Xeon® 6 SoC with P-Cores Processor, with 20 or 32 physical cores.
Memory	<ul style="list-style-type: none"> ■ 8 total DDR5 DIMM Slots, at up to 6400 MT/s RDIMMs ■ Up to 768GB of main memory with eight 96 GB DDR5-6400 DIMMs.
GPU	<ul style="list-style-type: none"> ■ One dedicated PCIe Gen5 GPU slot for a HHHL GPU
Networking	<ul style="list-style-type: none"> ■ Two rear-facing integrated 25 Gbps uplink ports connecting via chassis mid-plane to the embedded switches on both Cisco UCS XE9305 chassis management controllers. ■ Two front-facing integrated 10 Gbps RJ45 host ports.
Storage	<p>There are two types of flash storage options simultaneously available in the Cisco Compute Hyperconverged with Nutanix XE130c M8 Edge Server:</p> <ul style="list-style-type: none"> ■ Internal M.2 SSDs: Up to two M.2 SSDs protected by hardware RAID 1 ■ Front-Facing E3.S NVMe Drives: <ul style="list-style-type: none"> • Storage-Optimized” configuration: up to four E3.S NVMe drive slots • IO-Optimized” configuration: up to three E3.S NVMe drive slots
PCIe Adapter	<ul style="list-style-type: none"> ■ One PCIe Gen5 slot for a HHHL PCIe adapter requires IO-optimized configuration.
Front Panel Interfaces	<ul style="list-style-type: none"> ■ One KVM connector ■ One USB-C port
Power subsystem	Power is supplied from the Cisco UCS XE9305 chassis power supplies. The Cisco Compute Hyperconverged with Nutanix XE130c M8 Edge Server consumes a maximum of 425W.
Fans	Integrated in the Cisco UCS XE9305 chassis.
Integrated management processor	<ul style="list-style-type: none"> ■ The built-in Cisco Integrated Management Controller enables monitoring of Cisco Compute Hyperconverged with Nutanix XE130c M8 Edge Server inventory, health, and system event logs. ■ ASPEED AST2600

Table 1 Capabilities and Features (*continued*)

Capability/Feature	Description
Firmware standards	<ul style="list-style-type: none"> ■ UEFI Spec 2.9 ■ ACPI 6.5 ■ SMBIOS Ver 3.7
Front Indicators	<ul style="list-style-type: none"> ■ Power button and indicator ■ System activity indicator ■ Location button and indicator
Management	<ul style="list-style-type: none"> ■ Cisco Intersight software (SaaS, Virtual Appliance and Private Virtual Appliance)
Security	<ul style="list-style-type: none"> ■ The server supports an optional trusted platform module (TPM). Additional features include a secure boot FPGA and ACT2 anti-counterfeit provisions.

CONFIGURING THE CISCO COMPUTE HYPERCONVERGED WITH NUTANIX XE130C M8 EDGE SERVER

Follow these steps to configure the Cisco Compute Hyperconverged with Nutanix XE130c M8 Edge Server:

- [STEP 1 CHOOSE BASE SERVER SKU, page 9](#)
- [STEP 2 CHOOSE AI INTENT \(REQUIRED\), page 10](#)
- [STEP 3 SELECT MEMORY \(REQUIRED\), page 11](#)
- [STEP 4 CHOOSE GPUs \(OPTIONAL\), page 15](#)
- [STEP 5 SELECT M.2 BOOT RAID CONTROLLER and SATA SSDs \(REQUIRED\), page 16](#)
- [STEP 6 SELECT RISERS \(REQUIRED\), page 17](#)
- [STEP 7 SELECT DRIVES \(REQUIRED\), page 18](#)
- [STEP 8 CHOOSE OPTIONAL TRUSTED PLATFORM MODULE, page 19](#)
- [STEP 9 SELECT GUEST VM OPERATING SYSTEM LICENSES \(Optional\), page 20](#)
- [STEP 10 SELECT HYPERVISOR, page 21](#)
- [STEP 11 SELECT NUTANIX SOFTWARE AND NUTANIX PROFESSIONAL SERVICES, page 22](#)

STEP 1 CHOOSE BASE SERVER SKU

Top Level ordering product ID (PID) of the Cisco Compute Hyperconverged with Nutanix XE130c M8 Edge Server as shown in [Table 2](#).

Table 2 Top level ordering PID

Product ID (PID)	Description
HCIXE-M8-NTNX-MLB	Cisco Compute Hyperconverged XE-Series M8 with Nutanix MLB

Select the product ID (PID) of the Cisco Compute Hyperconverged with Nutanix XE130c M8 Edge Server as shown in [Table 3](#).



NOTE:

- The CPU core count is part of the SKU and cannot be changed. Choose nodes based on the desired CPU core count and the number of sleds.
- For HCIXENX130C-M8-20, HCIXENX130C-M8-32 (non-stand alone nodes): These are required selections, multi-select, with a minimum of 1 (out of 2 sleds) and a maximum of 5 total server per chassis.

Table 3 PID of the Base Cisco Compute Hyperconverged with Nutanix XE130c M8 Edge Server

Product ID (PID)	Description
HCIXENX130C-M8-20	Cisco Compute Hyperconverged XE130c M8 20-Core 1U Server without memory, risers, drives, GPUs, or adapters (ordered as a UCS XE9305 chassis option)
HCIXENX130C-M8-32	Cisco Compute Hyperconverged XE130c M8 32-Core 1U Server without memory, risers, drives, GPUs, or adapters (ordered as a UCS XE9305 chassis option)
HCIXENX130C-M8-20U	Cisco Compute Hyperconverged XE130c M8 20-Core 1U Server without memory, risers, drives, GPUs, or adapters (ordered standalone)
HCIXENX130C-M8-32U	Cisco Compute Hyperconverged XE130c M8 32-Core 1U Server without memory, risers, drives, GPUs, or adapters (ordered standalone)

A base Cisco Compute Hyperconverged with Nutanix XE130c M8 Edge Server ordered in [Table 3](#) does not include any components or options. They must be selected during product ordering.

Please follow the steps on the following pages to order components such as the following, which are required in a functional server:

- GPU
- Memory
- Risers
- Drives
- TPM

STEP 2 CHOOSE AI INTENT (REQUIRED)

Select AI Intent

The available AI Intent options are listed in [Table 4](#)



NOTE: For stand-alone (-U) server, a required AI Intent must be selected to define the primary use case.

Table 4 Available AI Intent

GPU Product ID (PID)	PID Description
COMPUTE-AI	Compute Artificial Intelligence Use Case
COMPUTE-OTHER	Compute Other Use Case

STEP 3 SELECT MEMORY (REQUIRED)

The [Table 5](#) below describes the main memory DIMM features supported on the server.

Table 5 Server Main Memory Features

Memory server technologies	Description
	DIMM
Intel® Xeon® CPU generation	Intel® Xeon® 6 SoC with P-Cores Processor
DDR5 memory clock speed	Intel® Xeon® 6 SoC CPU: Up to 5600 MT/s 1DPC
Operational voltage	1.1 Volts
DRAM fab density	16Gb and 24Gb
Memory type	RDIMM (Registered DDR5 DIMM)
Memory DRAM DIMM organization	Four memory DIMM channels per CPU; up to 2 DIMMs Per Channel
Maximum number of DRAM DIMM per server	8 (1-Socket)
DRAM DIMM Densities and Ranks	16GB 1Rx8, 32GB 1Rx4, 48GB 1Rx4, 64GB 2Rx4, 96GB 2Rx4
Maximum system memory capacity	768GB (8x96GB)

Figure 4 Memory Organization Block Diagram

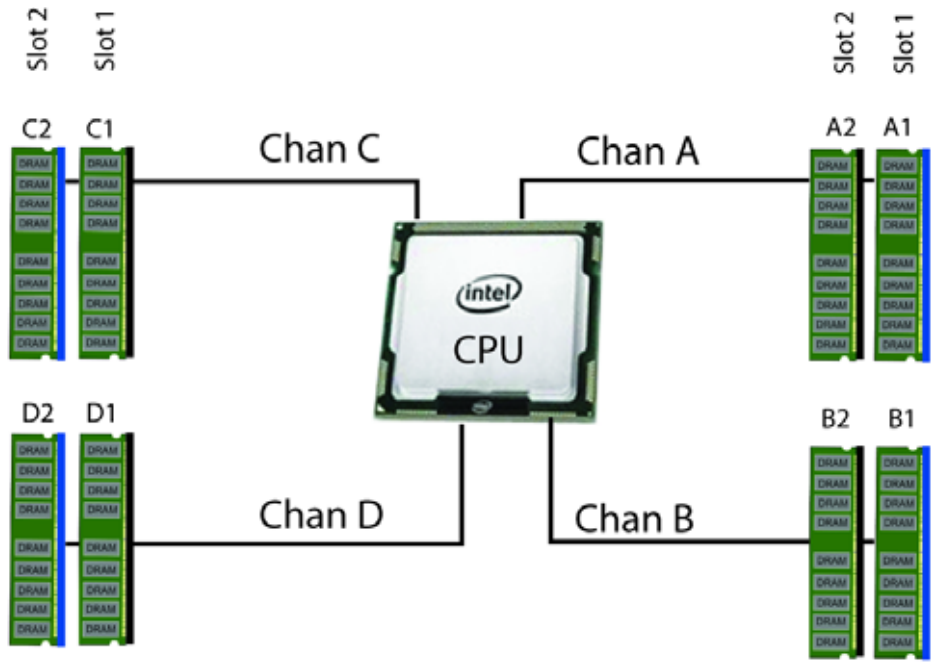

4 memory channels per CPU and up to 2 DIMMs per channel
8 DIMMs in total (Single CPU)

Select DIMMs

Select the memory configuration from [Table 6](#).



NOTE:

- When paired with Intel® Xeon® 6 SoC CPUs, all memory DIMMs must be Cisco DDR5-6400 memory PIDs, although the memory will operate at the maximum speed of the Intel® Xeon® 6 SoC CPUs memory controller, up to 5600 MT/s.

Table 6 Memory Options

Product ID (PID)	PID Description	Ranks/DIMM
DDR5-6400 MT/s Cisco Memory PIDs list¹		
HCIXE-MRX16G1RE5	16GB RDIMM 1Rx8 1.1Volts (16Gb)	1
HCIXE-MRX32G1RE5	32GB RDIMM 1Rx4 1.1Volts (16Gb)	1
HCIXE-MRX48G1RF5	48GB RDIMM 1Rx4 1.1Volts (24Gb)	1
HCIXE-MRX64G2RE5	64GB RDIMM 2Rx4 1.1Volts (16Gb)	2
HCIXE-MRX96G2RF5	96GB RDIMM 2Rx4 1.1Volts (24Gb)	2
Accessories/spare included with Memory configuration:		
<ul style="list-style-type: none"> ■ UCS-DDR5-BLK² is auto included for the unpopulated DIMM slots 		

Notes:

1. Memory will operate at the maximum speed of the Intel® Xeon® 6 SoC CPUs memory controller, up to 5600 MT/s. Check the [Table 7](#) for the CPU highest clock speed.
2. Any empty DIMM slot must be populated with a DIMM blank to maintain proper cooling airflow.

Table 7 Integrated Intel® Xeon® 6 Scalable CPUs

CPU Number (PID)	Cores (C)	Clock Freq (GHz)	Power (W)	Highest DDR5 DIMM Clock (MT/s)
6543P-B	32	2.00	160	5600
6513P-B	20	2.00	130	5600

Memory configurations and mixing rules

- **Golden Rule:** Memory on every CPU socket shall be configured identically. Unbalanced populations are unsupported. Mixing different DIMM densities within the channel or across the channel is not supported
- For full details on supported memory configuration, see the [UCS XE130C M8 Memory Guide](#).

STEP 4 CHOOSE GPUs (OPTIONAL)

Select GPU

The available server GPU options are listed in [Table 8](#)



NOTE:

- GPU selection is optional, with a maximum of 1 GPU per server.
- Selecting a GPU will require the necessary NVIDIA AI Enterprise (NVAIE) software license. For a complete list of supported GPUs, please refer to the Hardware and Software Compatibility List (HCL)

Table 8 Available GPU Card

GPU Product ID (PID)	PID Description
HCIXE-GPU-L4	NVIDIA L4:70W, 24GB, 1-slot HHHL GPU

STEP 5 SELECT M.2 BOOT RAID CONTROLLER and SATA SSDs (REQUIRED)

- **Select Cisco M.2 drives:** Order two matching M.2 drives. This connector accepts the boot-optimized RAID controller (see [Table 10](#)). Each boot-optimized RAID controller can accommodate two M.2 drives shown in [Table 9](#).



NOTE:

- Each boot-optimized RAID controller can accommodate two M.2 drives shown in [Table 9](#). The boot-optimized RAID controller plugs into the motherboard.
- Two M.2 drives are required for Nutanix cluster deployment.
- M.2 drives support UEFI boot mode only; legacy boot mode is not supported.

Table 9 M.2 Drives

Product ID (PID)	PID Description
HCIXE-M2-480G	480GB 2.5in M.2 SATA Micron G2 SSD
HCIXE-M24800A1V	480GB M.2 Boot Solidigm S4520 SATA 1X SSD

- **Cisco 6GB/s SATA Boot-Optimized M.2 RAID Controller (included):** Boot-Optimized RAID controller (HCIXE-M2I-HWRD-FPS) for hardware RAID across two SATA M.2 storage modules. The Boot-Optimized RAID controller plugs into the motherboard and the M.2 SATA drives plug into the Boot-Optimized RAID controller.



NOTE:

- The HCIXE-M2-HWRD2 is auto included with the server configuration if M.2 drives are selected.
- The HCIXE-M2-HWRD2 controller supports RAID 1 and JBOD mode is only available with M.2 SATA SSDs listed in [Table 9](#).
- Cisco Intersight is supported for configuring of volumes and monitoring of the controller and installed SATA M.2 drives
- Hot-plug replacement is not supported. The server must be powered off to replace.

Table 10 M.2 RAID Controller

Product ID (PID)	PID Description
HCIXE-M2-HWRD2	M.2 RAID Controller for HCI XE-Series servers

STEP 6 SELECT RISERS (REQUIRED)

The riser PIDs are listed in [Table 11](#).

Table 11 PIDs of the Risers

Product ID (PID)	Description	Approved Configurations
Storage Riser		
HCIXE-1U-E3S-2L	Left E3.S 2-Drive Riser Assembly for HCI Unified Edge server (4-drive back plane)	When the HCIXE-1U-E3S-1L storage riser is included in the server configuration, the HCIXE-1U-PCI-L IO riser is also required
HCIXE-1U-E3S-1L	Left E3.S 1-Drive Riser Assembly for HCI Unified Edge server (3-drive back plane)	
IO Riser		
HCIXE-1U-PCI-L	Left PCIe Riser for HCI Unified Edge server	When the HCIXE-1U-PCI-L IO riser is chosen for the server configuration, the HCIXE-1U-E3S-1L storage riser must also be selected

STEP 7 SELECT DRIVES (REQUIRED)

The standard disk drive features are:

- E3.S 1T NVMe Drives
- Hot-pluggable
- Drives come mounted in sleds

Select Drives

The available drives listed [Table 12](#).



NOTE:

- At least two E3.S drives are required for a HCI configuration.
- The maximum number of E3.S drives is 4 for If the HCIXE-1U-E3S-2L riser is selected.
- If the HCIXE-1U-PCI-L (Left PCIe Riser) is selected, the maximum number of E3.S drives is 3.

Table 12 Available E3.S 1T NVMe Drives

Product ID (PID)	PID Description	Speed	Capacity
HCIXE-NVE11T9K1V	1.9TB E3.S1T KCD8XPJE HgPerf MedEnd Gen5 1X NVMe (SIE SCEF)	1X	1.9 TB
HCIXE-NVE13T8K1V	3.8TB E3.S1T KCD8XPJE HgPerf MedEnd Gen5 1X NVMe (SIE SCEF)	1X	3.8 TB
HCIXE-NVE17T6K1V	7.6TB E3.S1T KCD8XPJE HgPerf MedEnd Gen5 1X NVMe (SIE SCEF)	1X	7.6 TB
HCIXE-NVE115T3K1V	15.3TB E3.S1T KCD8XPJE HgPerf MedEnd Gen5 1X NVMe (SIE SCEF)	1X	15.3 TB
Accessories/spare included with drives			
<ul style="list-style-type: none"> ■ HCIXE-E3S1T-F is included for any unpopulated front storage device bays. 			

STEP 8 CHOOSE OPTIONAL TRUSTED PLATFORM MODULE

Trusted Platform Module (TPM) is a computer chip or microcontroller that can securely store artifacts used to authenticate the platform or Cisco Compute Hyperconverged with Nutanix XE130c M8 Edge Server. These artifacts can include passwords, certificates, or encryption keys. A TPM can also be used to store platform measurements that help ensure that the platform remains trustworthy. Authentication (ensuring that the platform can prove that it is what it claims to be) and attestation (a process helping to prove that a platform is trustworthy and has not been breached) are necessary steps to ensure safer computing in all environments.

Table 13 Available TPM Option

Product ID (PID)	Description
HCIXE-TPM-002D	TPM 2.0 TCG FIPS140-2 CC+ Cert M7 Intel MSW2022 Compliant



NOTE:

- TPM selection is optional, with a maximum of 1 TPM per server.
- The TPM module used in this system conforms to TPM v2.0 as defined by the Trusted Computing Group (TCG).
- TPM installation is supported after-factory. However, a TPM installs with a one-way screw and cannot be replaced, upgraded, or moved to another server. If a Server with a TPM is returned, the replacement unit must be ordered with a new TPM. If there is no existing TPM in the Server, you can install a TPM 2.0. Refer to the following document for Installation location and instructions:

STEP 9 SELECT GUEST VM OPERATING SYSTEM LICENSES (Optional)

Select VM Operating System Licenses desired from [Table 14](#)



NOTE: Microsoft operating system: Optional Microsoft guest OS license that may be purchased for Virtual Machines that run on top of AHV hypervisor.

Table 14 Guest VM Operating System Licenses

Product ID (PID)	PID Description
Microsoft Options	
MSWS-25-ST16C	Windows Server 2025 Standard, 16 Cores
MSWS-25-ST16C-NS	Windows Server 2025 Standard, 16 Cores - No Cisco SVC
MSWS-25-ST24C	Windows Server 2025 Standard, 24 Cores
MSWS-25-ST24C-NS	Windows Server 2025 Standard, 24 Cores - No SVC
MSWS-25-DC16C	Windows Server 2025 Datacenter, 16 Cores
MSWS-25-DC16C-NS	Windows Server 2025 Datacenter, 16 Cores - No SVC
MSWS-25-DC24C	Windows Server 2025 Datacenter, 24 Cores
MSWS-25-DC24C-NS	Windows Server 2025 Datacenter, 24 Cores - No SVC

STEP 10 SELECT HYPERVISOR

Cisco Hypervisor options are listed in [Table 15](#).

Table 15 Hypervisor





Product ID (PID)	Description
HCIXE-AOSAHV75SWK9	Cisco Compute Hyperconverged Acropolis Operating System (AOS) Acropolis Hypervisor (AHV) 7.5 Software
HCI-AOSAHV-NO-OS	HCI AOS AHV No OS Factory Install-Special Approval Required

STEP 11 SELECT NUTANIX SOFTWARE AND NUTANIX PROFESSIONAL SERVICES

- **Top Level Nutanix Software And Professional Services PIDs on page 23**
 - Table 16, *Top Level Nutanix Software And Professional Services PIDs*
 - Table 17, *Nutanix NCI Software License Use case*
- **Nutanix Software And Professional Services PID Decoder on page 25**
 - Table 18.0, *Nutanix Software PID Decoder (WW-XX-YY-ZZ)*
 - Table 18.1, *Nutanix Professional Services PID Decoder (WW-XX-YY-ZZ)*
- **Nutanix Software PIDs and Description on page 26**
 - Table 21.0, *Nutanix Cloud Infrastructure (NCI)*
 - Table 21.1, *Nutanix Cloud Infrastructure Data (NCI-D)*
 - Table 21.2, *Nutanix Cloud Infrastructure Edge (NCI-E)*
 - Table 21.3, *End User Computing (EUC)*
 - Table 21.4, *Nutanix Cloud Manager (NCM)*
 - Table 21.3, *Nutanix Cloud Manager Edge (NME)*
 - Table 21.3, *Nutanix Cloud Manager EUC (NCM-U)*
 - Table 21.7, *Nutanix Cloud Platform (NCP)*
 - Table 21.8, *Nutanix Unified Storage™ (NUS)*
 - Table 21.9, *Nutanix Data Lens (NDL)*
 - Table 21.10, *Nutanix Kubernetes Platform (NKP)*
 - Table 21.11, *Nutanix Enterprise AI (NAI)*
- **Nutanix software limited orderability on page 62**
 - Table 22.0, *End User Computing Hyperspace (EUCH)*
- **Professional Services PIDs and Description on page 64**
 - Table 23.0, *NCI Design Workshop*
 - Table 23.1, *NCI Cluster Deployment or Expansion*
 - Table 23.2, *Virtual Machine Migration Workshop*
 - Table 23.3, *Virtual Machine Migration*
 - Table 23.4, *NCM Self-Service Design Workshop*
 - Table 23.5, *NCM Intelligent Operations Design Workshop*
 - Table 23.6, *NCM Intelligent Operations Deployment*
 - Table 23.7, *FastTrack for NCM Self-Service*
 - Table 23.8, *FastTrack for NCM Cost Governance*
 - Table 23.9, *NKP Design Workshop*
 - Table 23.10, *NKP Deployment*
 - Table 23.11, *Nutanix Flexible Credits*
- **Nutanix Support: on page 76**
- **Software With Professional Services PID Mapping on page 77**
 - Table 25.0, *Nutanix Software NCI, NCI-D, NCP (NCI-PRO), NCP (NCI-ULT), 1 YEAR SUBSCRIPTION with professional services PID Mapping*
 - Table 25.1, *Nutanix Software NCI, NCI-D, NCP (NCI-PRO), NCP (NCI-ULT), 3 YEAR SUBSCRIPTION with professional services PID Mapping*
 - Table 26, *Nutanix Software NCM STR 1 YEAR AND 3 YEAR & ABOVE SUBSCRIPTION with Professional Services PID Mapping*
 - Table 27, *Nutanix Software NCM PRO, NCM ULT, NCP (NCM-PRO), NCP (NCM-ULT) 1 YEAR AND 3 YEAR & ABOVE SUBSCRIPTION with Professional services*

Top Level Nutanix Software And Professional Services PIDs

Table 16 Top Level Nutanix Software And Professional Services PIDs

ATO Product ID (PID)	Description
NTX-SW	<p>Nutanix Software 3Y and above</p> <hr/>  NOTE: Please refer to the complete list of Nutanix Software PIDs and Description on page 26
NTX-SW-LO	<p>Nutanix Limited Orderable Software Offer</p> <hr/>  NOTE: Please refer to the complete list of Nutanix software limited orderability on page 62
NTX-SW-1Y	<p>Nutanix Software 1Y</p> <hr/>  NOTE: Please refer to the complete list of Nutanix Software PIDs and Description on page 26
NTX-NCI-USE-CASE ¹	<p>Nutanix NCI Software License Use case</p> <hr/>  NOTE: Please refer to the complete list of Nutanix Software PIDs and Description on page 26
NTX-SW-PS	<p>Nutanix Professional Service</p> <hr/>  NOTE: Please refer to the complete list of Professional Services PIDs and Description on page 64

Notes:

1. A selection of NTX-NCI-USE-CASE from Nutanix Software Category is required when Nutanix Cloud Infrastructure Software License (NCI / NCI-D / NCI-E) is selected. There are a few conditions under which NT-PUBLIC-CLOUD can be used. refer to the [KB article](#) for more details. Please choose one of them from the [Table 17](#), if you select the NTX-NCI-USE-CASE.

Table 17 Nutanix NCI Software License Use case

Product ID (PID)	Description
NT-ON-PREM-UCS	Use Case to License Nutanix SW on Certified Cisco UCS HW
NT-PUBLIC-CLOUD	Use Case to License Nutanix SW (NC2) Running in Public Cloud (AWS/Azure)Hide
NT-OTHER	Use Case for all other Nutanix SW that is not covered above

**NOTE:****(1) 1 Year Subscription term:**

- For Nutanix Cloud Infrastructure (NCI), Nutanix Cloud Infrastructure - Data (NCI-D) and Nutanix Cloud Manager (NCM) softwares, it requires mandatory attach of Nutanix Professional Services.

(2) 3 Year Subscription term:

- For Nutanix Cloud Infrastructure (NCI), Nutanix Cloud Infrastructure - Data (NCI-D) and Nutanix Cloud Manager (NCM), only Starter (STR) softwares, it is recommended to attach Nutanix Professional Services during ordering.
- For Nutanix Cloud Manager (NCM) software, only Professional (PRO) and Ultimate (ULT) softwares requires mandatory Nutanix Professional Services.

(3) Nutanix NCI Software License Use case:

- Ratio of cores between cloud and on-prem must be 70/30 or greater, meaning $\geq 30\%$ of cores must be licensed for on-prem usage. Cloud only deals, public cloud marketplace deals, and hybrid cloud deals with other vendor hardware are not allowed.
- Must include mention of hybrid cloud in your Nutanix deal registration.
- Must select the appropriate public cloud use-case SKU when building a CCW configuration.

(4) Any future expansion opportunity does not require **mandatory Nutanix Professional Services attach.**

(5) Cisco and Nutanix products are each subject to their own terms and conditions, including support timelines and milestones. This includes the Nutanix Cloud Platform software and qualified Cisco UCS hardware platforms sold together as part of the Cisco Compute Hyperconverged with Nutanix solution. Carefully review [Nutanix's EoL portal](#) for support timelines by hardware platform. Cisco's UCS hardware support milestones may not align with Nutanix's support milestones. Therefore, it is important to plan your hardware and software refresh cycles based on the earlier of the two dates (hardware support from Cisco and software support from Nutanix). It is your responsibility to check the Nutanix software term length desired against the support time frames for the quoted UCS hardware platform.

Nutanix licenses are transferable to newer generation Cisco UCS platforms subject to Nutanix's end user license agreement. Refer to [Nutanix's Support FAQs](#) for details and definitions of Nutanix's End of Life and End of Support Life milestones. Refer to [Cisco's EoL policy](#) for details and definitions of Cisco's End of Life and Last Date of Support milestones.

Nutanix Software And Professional Services PID Decoder

Table 18.0 Nutanix Software PID Decoder (WW-XX-YY-ZZ)

Identifier#1 (WW)	Identifier#2 (XX)	Identifier#3 (YY)	Identifier#4 (ZZ)
Nutanix Product Family:	Nutanix Software Type/Category:	License Tiers:	Support Tier:
NT	NCI: Nutanix Cloud Infrastructure NCI-D: Nutanix Cloud Infrastructure Data NCI-E: Nutanix Cloud Infrastructure Edge EUC: End User Computing NCM: Nutanix Cloud Manager NME: Nutanix Cloud Manager Edge NCM-U: Nutanix Cloud Manager End User Computing NCP: Nutanix Cloud Platform NUS: Nutanix Unified Storage™ NDL: Nutanix Data Lens NKP: Nutanix Kubernetes Platform NAI: Nutanix Enterprise AI EUCH: END User Computing Hyperspace	STR: Starter PRO: Professional ULT: Ultimate	PR: Production MC: Mission Critical AP: (ASP Production) AM: (ASP Mission Critical) FP: US Federal Production FM: US Federal Mission Critical
NOTE: Note for example “NT-NCI-STR-PR” PID can be decoded as, NT=Nutanix, NCI=Nutanix Cloud Infrastructure, STR=Starter, PR=Production			

Table 18.1 Nutanix Professional Services PID Decoder (WW-XX-YY-ZZ)

Identifier#1 (WW)	Identifier#2 (XX)	Identifier#3 (YY)	Identifier#4 (ZZ)
Nutanix Product Family:	Nutanix Professional Services Offering:	Nutanix Product Tier:	Nutanix Professional Services Option:
NT	Design W-DS: NCI Design Workshop W-SSD: NCM Self-Service Design Workshop W-OD: NCM Intelligent Operations Design Workshop W-KD: NKP Design Workshop Deploy S-DP: NCI Cluster Deployment or Expansion S-OP: NCM Intelligent Operations Deployment F-SS: FastTrack for NCM Self-Service F-CG: FastTrack for NCM Cost Governance S-KD: NKP Deployment Migrate W-MG: Virtual Machine Migration Workshop S-MG-VM: Virtual Machine Migration Custom FLEX-CST-CR: Flexible Credits	STR: Starter PRO: Professional ULT: Ultimate	Design SD: Standard Documentation Deploy AV-PB: Pro AHV Nodes Base AV-PV: Pro AHV Nodes Variable EX-PB: Pro ESX Nodes Base EX-PV: Pro ESX Nodes Variable AV-SB: Starter AHV Nodes Base AV-SV: Starter AHV Nodes Variable EX-SB: Starter ESX Nodes Base EX-SV: Starter ESX Nodes Variable AVB: Starter AHV Nodes Base AVV: Starter AHV Nodes Variable EXB: Starter ESX Nodes Base EXV: Starter ESX Nodes Variable AV-UB: Ultimate AHV Nodes Base AV-UV: Ultimate AHV Nodes Variable EX-UB: Ultimate ESX Nodes Base EX-UV: Ultimate ESX Nodes Variable
NOTE: Note for example “NT-W-DS-STR-SD” PID can be decoded as, NT=Nutanix, W-DS= Design Workshop, STR=Starter, SD= Standard Documentation			

Nutanix Software PIDs and Description

Table 19 Software Options and Metric

Software Option	Software Description	Metric
Nutanix Cloud Infrastructure (NCI)	NCI is a complete software stack to unify your hybrid cloud infrastructure including compute, storage and network, hypervisors, and containers, in public or enterprise clouds	Per Core
Nutanix Cloud Infrastructure Data (NCI-D)	Delivers rich data and storage services but does not include Nutanix compute and networking capabilities. No support for AHV	Per Core
Nutanix Cloud Infrastructure Edge (NCI-Edge)	Nutanix Cloud Infrastructure - Edge (NCI-Edge) provides a distributed infrastructure platform for small edge deployments. NCI-Edge provides the same capabilities as NCI, combining compute, storage, and networking resources from a cluster of servers into a single logical pool with integrated resiliency, security, performance, and simplified administration.	Per VM
Nutanix Cloud Manager (NCM)	NCM offers intelligent operations, self service and orchestration, visibility and governance of spend, security and teams	Per Core
Nutanix Cloud Manager Edge (NCM-E)	Provides NCM capabilities for Edge deployments	Per VM
Nutanix Cloud Manager EUC (NCM-U)	Provides NCM capabilities in VDI use cases	Per User
Nutanix Cloud Platform (NCP)	Bundle for NCI and NCM	Per Core
Nutanix Unified Storage™ (NUS)	Nutanix Unified Storage™ (NUS) is a software-defined data services platform that consolidates the management and protection of siloed block, file, and object storage into a single, unified platform.	Per TIB
Nutanix Data Lens (NDL)	Nutanix Data Lens is a SaaS-based cyberstorage solution offering ransomware resilience and global data visibility for unstructured data on Nutanix Unified Storage (NUS).	Per TIB
End User Computing (EUC)	on-prem VDI and Desktop as a Service (DaaS) use cases	Per User
Nutanix Kubernetes Platform (NKP)	Nutanix Kubernetes Platform (NKP) combines the Nutanix Kubernetes Engine (NKE) features with their acquisition of the D2iQ product family to bring a consolidated runtime, orchestration, and management environment to our cloud native customers.	Per Core/Per VM ¹
Nutanix Enterprise AI (NAI)	Nutanix Enterprise AI is a comprehensive software platform designed to simplify and secure the deployment, management, and scaling of generative AI (GenAI) applications.	Per Core/vCPU and GB ²

Notes:

1. For NKP FS STR/PRO/ULT, the metric is calculated per core, whereas for NKP PRO/ULT, the calculated is measured per VM.
2. For NAI both per core/vCPU and GPU memory (GB) licenses are required.

Table 20 Nutanix Software License Tiers

NCI Starter	NCI Professional	NCI Ultimate
<p>Core set of software functionality</p> <p>Ideal for: Small-scale deployments with a limited set of workloads (on-prem only)</p>	<p>Rich data services, resilience and management features</p> <p>Ideal for: Running multiple applications or large-scale single workload deployments (on-prem or in public clouds)</p>	<p>Full suite of Nutanix software capabilities to tackle complex infrastructure challenges</p> <p>Ideal for: Multi-site deployments and advanced security requirements (on-prem or in public clouds)</p>



NOTE:

- Prism Central will be required for all licensing actions.
- Licenses are portable across Cisco hardware platforms in HCL.

(1) Nutanix Cloud Infrastructure (NCI):

Nutanix Cloud Infrastructure (NCI) converges the entire datacenter stack, including compute, storage, storage networking, and virtualization and is at the core of creating a hyperconverged infrastructure environment. Complex and expensive legacy infrastructure is replaced by NCI, running on industry-standard servers loaded with the latest hardware technologies. This allows enterprises to deploy what you need for the short term, and scale on-demand as infrastructure needs increase over time. Each server, often referred to as a node in the context of HCI, is an x86 platform with direct-attached storage drives. NCI software runs on each node, distributing all operating functions across the cluster for superior performance and resilience, and enabling seamless scalability.



NOTE:

- For more information about Nutanix Cloud Infrastructure (NCI), please visit <https://www.nutanix.com/products/nutanix-cloud-infrastructure>
- For more information about Nutanix Cloud Platform software options, please visit <https://www.nutanix.com/products/cloud-platform/software-options>
- Please note that the Federal Support program is reserved for US Federal accounts. US Federal accounts must select Federal Support Tier for the order to be fulfilled. If a non-Federal account selects a Federal Support program, Nutanix may not fulfill the order. Additionally, Nutanix's Mixed Support Level Guidelines (<https://www.nutanix.com/support-services/product-support/support-policies-and-faqs?show=accordion-4>) requires all software assets within a cluster to have the same support level, else software support will default to the lower option.
- Sellers in the Federal space need to ensure they have the Federal Support SKU's on the quote and order. All orders without the Federal Support SKU's will be rejected by Nutanix. Refer this Knowledge base article for more info: <https://computekb.cisco.com/article/nutanix-support-for-federal-customers.html>
- Authorized Partners of Nutanix can offer Level 1 & Level 2 support for Nutanix Software. for the complete list visit <https://computekb.cisco.com/article/rules-for-ordering-nutanix-partner-support-skus.html>
- The quantity of NCI license must match with total number for processor cores in hardware platforms.

Table 21.0 Nutanix Cloud Infrastructure (NCI)

Product ID (PID)	PID Description
STR - STARTER	
NT-NCI-STR-PR	Subscription, Nutanix Cloud Infrastructure (NCI) Starter Software License & Production Software Support Service for 1 CPU Core
NT-NCI-STR-MC	Subscription, Nutanix Cloud Infrastructure (NCI) Starter Software License & Mission Critical Software Support Service for 1 CPU Core
NT-NCI-STR-AP	Subscription, Nutanix Cloud Infrastructure (NCI) Starter Software License & L3 Production Software Support Service for 1 CPU Core (Authorized Support Partners provides L1, L2 support)
NT-NCI-STR-AM	Subscription, Nutanix Cloud Infrastructure (NCI) Starter Software License & L3 Mission Critical Software Support Service for 1 CPU Core (Authorized Support Partners provides L1, L2 support)

Table 21.0 Nutanix Cloud Infrastructure (NCI)

NT-NCI-STR-FP	Subscription, Nutanix Cloud Infrastructure (NCI) Starter Software License & Federal Production Software Support Service for 1 CPU Core
NT-NCI-STR-FM	Subscription, Nutanix Cloud Infrastructure (NCI) Starter Software License & Federal Mission Critical Software Support Service for 1 CPU Core
PRO - PROFESSIONAL	
NT-NCI-PRO-PR	Subscription, Nutanix Cloud Infrastructure (NCI) Pro Software License & Production Software Support Service for 1 CPU Core
NT-NCI-PRO-MC	Subscription, Nutanix Cloud Infrastructure (NCI) Pro Software License & Mission Critical Software Support Service for 1 CPU Core
NT-NCI-PRO-AP	Subscription, Nutanix Cloud Infrastructure (NCI) Professional Software License & L3 Production Software Support Service for 1 CPU Core (Authorized Support Partners provides L1, L2 support)
NT-NCI-PRO-AM	Subscription, Nutanix Cloud Infrastructure (NCI) Professional Software License & L3 Mission Critical Software Support Service for 1 CPU Core (Authorized Support Partners provides L1, L2 support)
NT-NCI-PRO-FP	Subscription, Nutanix Cloud Infrastructure (NCI) Pro Software License & Federal Production Software Support Service for 1 CPU Core
NT-NCI-PRO-FM	Subscription, Nutanix Cloud Infrastructure (NCI) Pro Software License & Federal Mission Critical Software Support Service for 1 CPU Core
ULT - ULTIMATE	
NT-NCI-ULT-PR	Subscription, Nutanix Cloud Infrastructure (NCI) Ultimate Software License & Production Software Support Service for 1 CPU Core
NT-NCI-ULT-MC	Subscription, Nutanix Cloud Infrastructure (NCI) Ultimate Software License & Mission Critical Software Support Service for 1 CPU Core
NT-NCI-ULT-AP	Subscription, Nutanix Cloud Infrastructure (NCI) Ultimate Software License & L3 Production Software Support Service for 1 CPU Core (Authorized Support Partners provides L1, L2 support)
NT-NCI-ULT-AM	Subscription, Nutanix Cloud Infrastructure (NCI) Ultimate Software License & Mission Critical Software Support Service for 1 CPU Core (Authorized Support Partners provides L1, L2 support)
NT-NCI-ULT-FP	Subscription, Nutanix Cloud Infrastructure (NCI) Ultimate Software License & Federal Production Software Support Service for 1 CPU Core
NT-NCI-ULT-FM	Subscription, Nutanix Cloud Infrastructure (NCI) Ultimate Software License & Federal Mission Critical Software Support Service for 1 CPU Core
ADVANCED REPLICATION	
NT-A-NCI-ADR-PR	Subscription, Nutanix Cloud Infrastructure (NCI) Advanced Replication add-on Software License & Production Software Support Service for 1 CPU Core
NT-A-NCI-ADR-MC	Subscription, Nutanix Cloud Infrastructure (NCI) Advanced Replication add-on Software License & Mission Critical Software Support Service for 1 CPU Core

Table 21.0 Nutanix Cloud Infrastructure (NCI)

NT-A-NCI-ADR-AP	Subscription, Nutanix Cloud Infrastructure (NCI) Advanced Replication add-on Software License & L3 Production Software Support Service for 1 CPU Core (Authorized Support Partners provides L1, L2 support)
NT-A-NCI-ADR-AM	Subscription, Nutanix Cloud Infrastructure (NCI) Advanced Replication add-on Software License & L3 Mission Critical Software Support Service for 1 CPU Core (Authorized Support Partners provides L1, L2 support)
NT-A-NCI-ADR-FP	Subscription, Nutanix Cloud Infrastructure (NCI) Advanced Replication add-on Software License & Federal Production Software Support Service for 1 CPU Core
NT-A-NCI-ADR-FM	Subscription, Nutanix Cloud Infrastructure (NCI) Advanced Replication add-on Software License & Federal Mission Critical Software Support Service for 1 CPU Core
SECURITY	
NT-A-NCI-SEC-PR	Subscription, Nutanix Cloud Infrastructure (NCI) Security add-on Software License & Production Software Support Service for 1 CPU Core
NT-A-NCI-SEC-MC	Subscription, Nutanix Cloud Infrastructure (NCI) Security add-on Software License & Mission Critical Software Support Service for 1 CPU Core
NT-A-NCI-SEC-AP	Subscription, Nutanix Cloud Infrastructure (NCI) Security add-on Software License & L3 Production Software Support Service for 1 CPU Core (Authorized Support Partners provides L1, L2 support)
NT-A-NCI-SEC-AM	Subscription, Nutanix Cloud Infrastructure (NCI) Security add-on Software License & L3 Mission Critical Software Support Service for 1 CPU Core (Authorized Support Partners provides L1, L2 support)
NT-A-NCI-SEC-FP	Subscription, Nutanix Cloud Infrastructure (NCI) Security add-on Software License & Federal Production Software Support Service for 1 CPU Core
NT-A-NCI-SEC-FM	Subscription, Nutanix Cloud Infrastructure (NCI) Security add-on Software License & Federal Mission Critical Software Support Service for 1 CPU Core

[Table 25.0, Nutanix Software NCI, NCI-D, NCP \(NCI-PRO\), NCP \(NCI-ULT\), 1 YEAR SUBSCRIPTION with professional services PID Mapping](#)

[Table 25.1, Nutanix Software NCI, NCI-D, NCP \(NCI-PRO\), NCP \(NCI-ULT\), 3 YEAR SUBSCRIPTION with professional services PID Mapping](#)

(2) Nutanix Cloud Infrastructure Data (NCI-D):

Nutanix supports freedom of choice of hypervisor and container platform, by offering a version called NCI Data that delivers rich data and storage services but does not include Nutanix compute and networking capabilities. Support for Hypervisor specific features, such as GPU support on ESXi, is not impacted by NCI Data licensing tiers.



NOTE:

- For more information about Nutanix Cloud Infrastructure (NCI), please visit <https://www.nutanix.com/products/nutanix-cloud-infrastructure>
- For more information about Nutanix Cloud Platform software options, please visit <https://www.nutanix.com/products/cloud-platform/software-options> Please note, the grey rows in the software options table under NCI are not included in NCI Data.
- Please note that the Federal Support program is reserved for US Federal accounts. US Federal accounts must select Federal Support Tier for the order to be fulfilled. If a non-Federal account selects a Federal Support program, Nutanix may not fulfill the order. Additionally, Nutanix's Mixed Support Level Guidelines(<https://www.nutanix.com/support-services/product-support/support-policies-and-faqs?show=accordion-4>) requires all software assets within a cluster to have the same support level, else software support will default to the lower option.
- Sellers in the Federal space need to ensure they have the Federal Support SKU's on the quote and order. All orders without the Federal Support SKU's will be rejected by Nutanix. Refer this Knowledge base article for more info: <https://compute.kb.cisco.com/article/nutanix-support-for-federal-customers.html>
- Authorized Partners of Nutanix can offer Level 1 & Level 2 support for Nutanix Software. for the complete list visit <https://compute.kb.cisco.com/article/rules-for-ordering-nutanix-partner-support-skus.html>
- The quantity of NCI-D license must match with total number for processor cores in hardware platforms.

Table 21.1 Nutanix Cloud Infrastructure Data (NCI-D)

Product ID (PID)	PID Description
STR - STARTER	
NT-NCI-D-STR-PR	Subscription, Nutanix Cloud Infrastructure Data (NCI-D) Starter Software License & Production Software Support Service for 1 CPU Core
NT-NCI-D-STR-MC	Subscription, Nutanix Cloud Infrastructure Data (NCI-D) Starter Software License & Mission Critical Software Support Service for 1 CPU Core
NT-NCI-D-STR-AP	Subscription, Nutanix Cloud Infrastructure Data (NCI-D) Starter Software License & L3 Production Software Support Service for 1 CPU Core (Authorized Support Partners provides L1, L2 support)
NT-NCI-D-STR-AM	Subscription, Nutanix Cloud Infrastructure Data (NCI-D) Starter Software License & L3 Mission Critical Software Support Service for 1 CPU Core (Authorized Support Partners provides L1, L2 support)
NT-NCI-D-STR-FP	Subscription, Nutanix Cloud Infrastructure Data (NCI-D) Starter Software License & Federal Production Software Support Service for 1 CPU Core
NT-NCI-D-STR-FM	Subscription, Nutanix Cloud Infrastructure Data (NCI-D) Starter Software License & Federal Mission Critical Software Support Service for 1 CPU Core

Table 21.1 Nutanix Cloud Infrastructure Data (NCI-D)

PRO - PROFESSIONAL	
NT-NCI-D-PRO-PR	Subscription, Nutanix Cloud Infrastructure Data (NCI-D) Pro Software License & Production Software Support Service for 1 CPU Core
NT-NCI-D-PRO-MC	Subscription, Nutanix Cloud Infrastructure Data (NCI-D) Pro Software License & Mission Critical Software Support Service for 1 CPU Core
NT-NCI-D-PRO-AP	Subscription, Nutanix Cloud Infrastructure Data (NCI-D) Pro Software License & L3 Production Software Support Service for 1 CPU Core (Authorized Support Partners provides L1, L2 support)
NT-NCI-D-PRO-AM	Subscription, Nutanix Cloud Infrastructure Data (NCI-D) Pro Software License & L3 Mission Critical Software Support Service for 1 CPU Core (Authorized Support Partners provides L1, L2 support)
NT-NCI-D-PRO-FP	Subscription, Nutanix Cloud Infrastructure Data (NCI-D) Pro Software License & Federal Production Software Support Service for 1 CPU Core
NT-NCI-D-PRO-FM	Subscription, Nutanix Cloud Infrastructure Data (NCI-D) Pro Software License & Federal Mission Critical Software Support Service for 1 CPU Core
ULT - ULTIMATE	
NT-NCI-D-ULT-PR	Subscription, Nutanix Cloud Infrastructure Data (NCI-D) Ultimate Software License & Production Software Support Service for 1 CPU Core
NT-NCI-D-ULT-MC	Subscription, Nutanix Cloud Infrastructure Data (NCI-D) Ultimate Software License & Mission Critical Software Support Service for 1 CPU Core
NT-NCI-D-ULT-AP	Subscription, Nutanix Cloud Infrastructure Data (NCI-D) Ultimate Software License & L3 Production Software Support Service for 1 CPU Core (Authorized Support Partners provides L1, L2 support)
NT-NCI-D-ULT-AM	Subscription, Nutanix Cloud Infrastructure Data (NCI-D) Ultimate Software License & L3 Mission Critical Software Support Service for 1 CPU Core (Authorized Support Partners provides L1, L2 support)
NT-NCI-D-ULT-FP	Subscription, Nutanix Cloud Infrastructure Data (NCI-D) Ultimate Software License & Federal Production Software Support Service for 1 CPU Core
NT-NCI-D-ULT-FM	Subscription, Nutanix Cloud Infrastructure Data (NCI-D) Ultimate Software License & Federal Mission Critical Software Support Service for 1 CPU Core
ADVANCED REPLICATION	
NT-A-NCI-D-ADR-PR	Subscription, Nutanix Cloud Infrastructure Data (NCI-D) Advanced Replication add-on Software License & Production Software Support Service for 1 CPU Core
NT-A-NCI-D-ADR-MC	Subscription, Nutanix Cloud Infrastructure Data (NCI-D) Advanced Replication add-on Software License & Mission Critical Software Support Service for 1 CPU Core
NT-A-NCI-D-ADR-AP	Subscription, Nutanix Cloud Infrastructure Data (NCI-D) Advanced Replication add-on Software License & L3 Production Software Support Service for 1 CPU Core (Authorized Support Partners provides L1, L2 support)

Table 21.1 Nutanix Cloud Infrastructure Data (NCI-D)

NT-A-NCI-D-ADR-AM	Subscription, Nutanix Cloud Infrastructure Data (NCI-D) Advanced Replication add-on Software License & L3 Mission Critical Software Support Service for 1 CPU Core (Authorized Support Partners provides L1, L2 support)
NT-A-NCI-D-ADR-FP	Subscription, Nutanix Cloud Infrastructure Data (NCI-D) Advanced Replication add-on Software License & Federal Production Software Support Service for 1 CPU Core
NT-A-NCI-D-ADR-FM	Subscription, Nutanix Cloud Infrastructure Data (NCI-D) Advanced Replication add-on Software License & Federal Mission Critical Software Support Service for 1 CPU Core
SECURITY	
NT-A-NCI-D-SEC-PR	Subscription, Nutanix Cloud Infrastructure Data (NCI-D) Security add-on Software License & Production Software Support Service for 1 CPU Core
NT-A-NCI-D-SEC-MC	Subscription, Nutanix Cloud Infrastructure Data (NCI-D) Security add-on Software License & Mission Critical Software Support Service for 1 CPU Core
NT-A-NCI-D-SEC-AP	Subscription, Nutanix Cloud Infrastructure Data (NCI-D) Security add-on Software License & L3 Production Software Support Service for 1 CPU Core (Authorized Support Partners provides L1, L2 support)
NT-A-NCI-D-SEC-AM	Subscription, Nutanix Cloud Infrastructure Data (NCI-D) Security add-on Software License & L3 Mission Critical Software Support Service for 1 CPU Core (Authorized Support Partners provides L1, L2 support)
NT-A-NCI-D-SEC-FP	Subscription, Nutanix Cloud Infrastructure Data (NCI-D) Security add-on Software License & Federal Production Software Support Service for 1 CPU Core
NT-A-NCI-D-SEC-FM	Subscription, Nutanix Cloud Infrastructure Data (NCI-D) Security add-on Software License & Federal Mission Critical Software Support Service for 1 CPU Core

[Table 25.0, Nutanix Software NCI, NCI-D, NCP \(NCI-PRO\), NCP \(NCI-ULT\), 1 YEAR SUBSCRIPTION with professional services PID Mapping](#)

[Table 25.1, Nutanix Software NCI, NCI-D, NCP \(NCI-PRO\), NCP \(NCI-ULT\), 3 YEAR SUBSCRIPTION with professional services PID Mapping](#)

(3) Nutanix Cloud Infrastructure Edge (NCI-E):

Nutanix Cloud Infrastructure - Edge (NCI-E) provides a distributed infrastructure platform for small edge deployments. NCI-Edge provides the same capabilities as NCI, combining compute, storage, and networking resources from a cluster of servers into a single logical pool with integrated resiliency, security, performance, and simplified administration. With NCI-Edge, organizations can efficiently extend the Nutanix platform to remote office/branch office (ROBO) and other edge use cases.

- 1 TiB of NUS Pro per NCI-Edge cluster is included at no cost with NCI-Edge.
- NCI-Edge licenses must run on a dedicated licensed cluster with no core-based licensing. Mixing of NCI-Edge licenses with other types of NCI licensing within a cluster is not supported.
- NCI-Edge can be used with any cluster deployment type as long as the conditions mentioned are followed.
- Maximum nodes for the Edge cluster is 5.



NOTE:

- For more information about Nutanix Cloud Infrastructure (NCI), please visit <https://www.nutanix.com/products/nutanix-cloud-infrastructure>
- For more information about Nutanix NCI Edge software options, please visit <https://www.nutanix.com/products/cloud-platform/software-options>
- Please note that the Federal Support program is reserved for US Federal accounts. US Federal accounts must select Federal Support Tier for the order to be fulfilled. If a non-Federal account selects a Federal Support program, Nutanix may not fulfill the order. Additionally, Nutanix's Mixed Support Level Guidelines (<https://www.nutanix.com/support-services/product-support/support-policies-and-faqs?show=acordion-4>) requires all software assets within a cluster to have the same support level, else software support will default to the lower option.
- Sellers in the Federal space need to ensure they have the Federal Support SKU's on the quote and order. All orders without the Federal Support SKU's will be rejected by Nutanix. Refer this Knowledge base article for more info: <https://computekb.cisco.com/article/nutanix-support-for-federal-customers.html>
- Authorized Partners of Nutanix can offer Level 1 & Level 2 support for Nutanix Software. for the complete list visit <https://computekb.cisco.com/article/rules-for-ordering-nutanix-partner-support-skus.html>
- NCI-Edge is limited to a maximum of 25 VMs in a cluster, with each VM being limited to a maximum of 96GB of memory.
- The quantity of NCI-Edge license must match with Total number for VMs running in the cluster.
- For the purpose of calculation, internal VMs (or Nutanix infrastructure VMs) such as Controller VM or Prism Central VM are not counted.

Table 21.2 Nutanix Cloud Infrastructure Edge (NCI-E)

Product ID (PID)	PID Description
STR - STARTER	
NT-NCI-E-STR-PR	Subscription, Nutanix Cloud Infrastructure (NCI) Starter Software License for Edge sites & Production Software Support Service for 1 VM
NT-NCI-E-STR-MC	Subscription, Nutanix Cloud Infrastructure (NCI) Starter Software License for Edge sites & Mission Critical Software Support Service for 1 VM
NT-NCI-E-STR-AP	Subscription, Nutanix Cloud Infrastructure (NCI) Starter Software License for Edge sites & L3 Production Software Support Service for 1 VM (Authorized Support Partners provides L1, L2 support)

Table 21.2 Nutanix Cloud Infrastructure Edge (NCI-E)

NT-NCI-E-STR-AM	Subscription, Nutanix Cloud Infrastructure (NCI) Starter Software License for Edge sites & L3 Mission Critical Software Support Service for 1 VM (Authorized Support Partners provides L1, L2 support)
NT-NCI-E-STR-FP	Subscription, Nutanix Cloud Infrastructure (NCI) Starter Software License for Edge sites & Federal Production Software Support Service for 1 VM
NT-NCI-E-STR-FM	Subscription, Nutanix Cloud Infrastructure (NCI) Starter Software License for Edge sites & Federal Mission Critical Software Support Service for 1 VM
PRO - PROFESSIONAL	
NT-NCI-E-PRO-PR	Subscription, Nutanix Cloud Infrastructure (NCI) Pro Software License for Edge sites & Production Software Support Service for 1 VM
NT-NCI-E-PRO-MC	Subscription, Nutanix Cloud Infrastructure (NCI) Pro Software License for Edge sites & Mission Critical Software Support Service for 1 VM
NT-NCI-E-PRO-AP	Subscription, Nutanix Cloud Infrastructure (NCI) Pro Software License for Edge sites & L3 Production Software Support Service for 1 VM (Authorized Support Partners provides L1, L2 support)
NT-NCI-E-PRO-AM	Subscription, Nutanix Cloud Infrastructure (NCI) Pro Software License for Edge sites & L3 Mission Critical Software Support Service for 1 VM (Authorized Support Partners provides L1, L2 support)
NT-NCI-E-PRO-FP	Subscription, Nutanix Cloud Infrastructure (NCI) Pro Software License for Edge sites & Federal Production Software Support Service for 1 VM
NT-NCI-E-PRO-FM	Subscription, Nutanix Cloud Infrastructure (NCI) Pro Software License for Edge sites & Federal Mission Critical Software Support Service for 1 VM
ULT - ULTIMATE	
NT-NCI-E-ULT-PR	Subscription, Nutanix Cloud Infrastructure (NCI) Ultimate Software License for Edge sites & Production Software Support Service for 1 VM
NT-NCI-E-ULT-MC	Subscription, Nutanix Cloud Infrastructure (NCI) Ultimate Software License for Edge sites & Mission Critical Software Support Service for 1 VM
NT-NCI-E-ULT-AP	Subscription, Nutanix Cloud Infrastructure (NCI) Ultimate Software License for Edge sites & L3 Production Software Support Service for 1 VM (Authorized Support Partners provides L1, L2 support)
NT-NCI-E-ULT-AM	Subscription, Nutanix Cloud Infrastructure (NCI) Ultimate Software License for Edge sites & L3 Mission Critical Software Support Service for 1 VM (Authorized Support Partners provides L1, L2 support)
NT-NCI-E-ULT-FP	Subscription, Nutanix Cloud Infrastructure (NCI) Ultimate Software License for Edge sites & Federal Production Software Support Service for 1 VM
NT-NCI-E-ULT-FM	Subscription, Nutanix Cloud Infrastructure (NCI) Ultimate Software License for Edge sites & Federal Mission Critical Software Support Service for 1 VM

[Table 25.0, Nutanix Software NCI, NCI-D, NCP \(NCI-PRO\), NCP \(NCI-ULT\), 1 YEAR SUBSCRIPTION with professional services PID Mapping](#)

[Table 25.1, Nutanix Software NCI, NCI-D, NCP \(NCI-PRO\), NCP \(NCI-ULT\), 3 YEAR SUBSCRIPTION with professional services PID Mapping](#)

(4) End User Computing (EUC):

Per user model offers hybrid cloud infrastructure capabilities appropriate for on-prem virtual desktop infrastructure (VDI) and Desktop as a Service (DaaS) use cases with pricing based on a Maximum Concurrent User basis (maximum number of provisioned end-user VMs). EUC per user is an alternative to the core-based NCI licensing option and is designed to provide simple, transparent licensing for all VDI users, regardless of the underlying hardware, hypervisor, or cloud.

- **Agnostic:** Works with any EUC management platform including Citrix Virtual Apps & Desktops and VMware Horizon
- **Term license:** Term license must run on a dedicated software licensed VDI cluster with no core-based licensing. Mixing of non-VDI workloads is not supported
- **Unified Storage:** Built-in and also available as a per TiB base add-on
- No additional license cost for DR site
- Portable across on-premises and public cloud, public cloud use requires Ultimate edition
- Available in Starter, Pro, and Ultimate editions
- Cloud Native and Database Service Add-ons not available with NCI EUC. Advanced Replication and Security Add-on features require NCI Ultimate edition

	EUC STARTER	EUC PROFESSIONAL	VDI ULTIMATE
NCI Feature Set	Everything in NCI Starter	Everything in NCI Professional	Everything in NCI Ultimate
Nutanix Unified Storage	1 TiB Free Capacity	50 GB Per User	100GB Per User



NOTE:

- For more information on End User Computing (EUC), please visit <https://www.nutanix.com/solutions/end-user-computing>
- For more information about Nutanix Cloud Platform software options, please visit <https://www.nutanix.com/products/cloud-platform/software-options>
- If the end user wants to run a mixed workload on same server (virtual machines that are not part of the VDI environment), NCI license is required.
- Please note that the Federal Support program is reserved for US Federal accounts. US Federal accounts must select Federal Support Tier for the order to be fulfilled. If a non-Federal account selects a Federal Support program, Nutanix may not fulfill the order. Additionally, Nutanix's Mixed Support Level Guidelines(<https://www.nutanix.com/support-services/product-support/support-policies-and-faqs?show=accordion-4>) requires all software assets within a cluster to have the same support level, else software support will default to the lower option.
- Sellers in the Federal space need to ensure they have the Federal Support SKU's on the quote and order. All orders without the Federal Support SKU's will be rejected by Nutanix. Refer this Knowledge base article for more info: <https://computekb.cisco.com/article/nutanix-support-for-federal-customers.html>
- Authorized Partners of Nutanix can offer Level 1 & Level 2 support for Nutanix Software. for the complete list visit <https://computekb.cisco.com/article/rules-for-ordering-nutanix-partner-support-skus.html>
- For 'PURE" EUC/VDI environment, there is no NCI license required.

Table 21.3 End User Computing (EUC)

Product ID (PID)	PID Description
STR - STARTER	
NT-EUC-STR-PR	Subscription, End User Computing (EUC) Starter Software License & Production Software Support Service for 1 User
NT-EUC-STR-MC	Subscription, End User Computing (EUC) Starter Software License & Mission Critical Software Support Service for 1 User
NT-EUC-STR-AP	Subscription, End User Computing (EUC) Starter Software License & L3 Production Software Support Service for 1 User (Authorized Support Partners provides L1, L2 support)
NT-EUC-STR-AM	Subscription, End User Computing (EUC) Starter Software License & L3 Mission Critical Software Support Service for 1 User (Authorized Support Partners provides L1, L2 support)
NT-EUC-STR-FP	Subscription, End User Computing (EUC) Starter Software License & Federal Production Software Support Service for 1 User
NT-EUC-STR-FM	Subscription, End User Computing (EUC) Starter Software License & Federal Mission Critical Software Support Service for 1 User
PRO- PROFESSIONAL	
NT-EUC-PRO-PR	Subscription, End User Computing (EUC) Pro Software License & Production Software Support Service for 1 User
NT-EUC-PRO-MC	Subscription, End User Computing (EUC) Pro Software License & Mission Critical Software Support Service for 1 User
NT-EUC-PRO-AP	Subscription, End User Computing (EUC) Pro Software License & L3 Production Software Support Service for 1 User (Authorized Support Partners provides L1, L2 support)
NT-EUC-PRO-AM	Subscription, End User Computing (EUC) Pro Software License & L3 Mission Critical Software Support Service for 1 User (Authorized Support Partners provides L1, L2 support)
NT-EUC-PRO-FP	Subscription, End User Computing (EUC) Pro Software License & Federal Production Software Support Service for 1 User
NT-EUC-PRO-FM	Subscription, End User Computing (EUC) Pro Software License & Federal Mission Critical Software Support Service for 1 User
ULT - ULTIMATE	
NT-EUC-ULT-PR	Subscription, End User Computing (EUC) Ultimate Software License & Production Software Support Service for 1 User
NT-EUC-ULT-MC	Subscription, End User Computing (EUC) Ultimate Software License & Mission Critical Software Support Service for 1 User
NT-EUC-ULT-AP	Subscription, End User Computing (EUC) Ultimate Software License & L3 Production Software Support Service for 1 User (Authorized Support Partners provides L1, L2 support)

Table 21.3 End User Computing (EUC)

NT-EUC-ULT-AM	Subscription, End User Computing (EUC) Ultimate Software License & L3 Mission Critical Software Support Service for 1 User (Authorized Support Partners provides L1, L2 support)
NT-EUC-ULT-FP	Subscription, End User Computing (EUC) Ultimate Software License & Federal Production Software Support Service for 1 User
NT-EUC-ULT-FM	Subscription, End User Computing (EUC) Ultimate Software License & Federal Mission Critical Software Support Service for 1 User

[Table 25.0, Nutanix Software NCI, NCI-D, NCP \(NCI-PRO\), NCP \(NCI-ULT\), 1 YEAR SUBSCRIPTION with professional services PID Mapping](#)

[Table 25.1, Nutanix Software NCI, NCI-D, NCP \(NCI-PRO\), NCP \(NCI-ULT\), 3 YEAR SUBSCRIPTION with professional services PID Mapping](#)

(5) Nutanix Cloud Manager (NCM):

Nutanix Cloud Manager (NCM) is a hybrid multi-cloud management platform for building a cloud operating model. NCM provides Intelligent Operations, Self-Service, Cost Governance, and Security natively with the Nutanix Platform or through a SaaS subscription.

- Self-service VMs and Apps are defined via simple blueprints, easily created, and managed via GUI/CLI.
- Management of IT lifecycle includes visibility, optimization, and financial control over multi-cloud deployments.
- Detect, monitor, and remediate security vulnerabilities and compliance near real-time across multiple cloud environment



NOTE:

- For more information Nutanix Cloud Manager (NCM), please visit <https://www.nutanix.com/products/cloud-manager>
- For more information about Nutanix Cloud Platform software options, please visit <https://www.nutanix.com/products/cloud-platform/software-options>
- Please note that the Federal Support program is reserved for US Federal accounts. US Federal accounts must select Federal Support Tier for the order to be fulfilled. If a non-Federal account selects a Federal Support program, Nutanix may not fulfill the order. Additionally, Nutanix's Mixed Support Level Guidelines(<https://www.nutanix.com/support-services/product-support/support-policies-and-faqs?show=accordion-4>) requires all software assets within a cluster to have the same support level, else software support will default to the lower option.
- Sellers in the Federal space need to ensure they have the Federal Support SKU's on the quote and order. All orders without the Federal Support SKU's will be rejected by Nutanix. Refer this Knowledge base article for more info: <https://computekb.cisco.com/article/nutanix-support-for-federal-customers.html>
- Authorized Partners of Nutanix can offer Level 1 & Level 2 support for Nutanix Software. For the complete list visit <https://computekb.cisco.com/article/rules-for-ordering-nutanix-partner-support-skus.html>
- The quantity of NCM license must match with total number for processor cores in hardware platforms.

Table 21.4 Nutanix Cloud Manager (NCM)

Product ID (PID)	PID Description
STR - STARTER	
NT-NCM-STR-PR	Subscription, Nutanix Cloud Manager (NCM) Starter Software License & Production Software Support Service for 1 CPU Core
NT-NCM-STR-MC	Subscription, Nutanix Cloud Manager (NCM) Starter Software License & Mission Critical Software Support Service for 1 CPU Core
NT-NCM-STR-AP	Subscription, Nutanix Cloud Manager (NCM) Starter Software License & L3 Production Software Support Service for 1 CPU Core (Authorized Support Partners provides L1, L2 support)
NT-NCM-STR-AM	Subscription, Nutanix Cloud Manager (NCM) Starter Software License & L3 Mission Critical Software Support Service for 1 CPU Core (Authorized Support Partners provides L1, L2 support)

Table 21.4 Nutanix Cloud Manager (NCM)

NT-NCM-STR-FP	Subscription, Nutanix Cloud Manager (NCM) Starter Software License & Federal Production Software Support Service for 1 CPU Core
NT-NCM-STR-FM	Subscription, Nutanix Cloud Manager (NCM) Starter Software License & Federal Mission Critical Software Support Service for 1 CPU Core
PRO - PROFESSIONAL	
NT-NCM-PRO-PR	Subscription, Nutanix Cloud Manager (NCM) Pro Software License & Production Software Support Service for 1 CPU Core
NT-NCM-PRO-MC	Subscription, Nutanix Cloud Manager (NCM) Pro Software License & Mission Critical Software Support Service for 1 CPU Core
NT-NCM-PRO-AP	Subscription, Nutanix Cloud Manager (NCM) Pro Software License & L3 Production Software Support Service for 1 CPU Core (Authorized Support Partners provides L1, L2 support)
NT-NCM-PRO-AM	Subscription, Nutanix Cloud Manager (NCM) Pro Software License & L3 Mission Critical Software Support Service for 1 CPU Core (Authorized Support Partners provides L1, L2 support)
NT-NCM-PRO-FP	Subscription, Nutanix Cloud Manager (NCM) Pro Software License & Federal Production Software Support Service for 1 CPU Core
NT-NCM-PRO-FM	Subscription, Nutanix Cloud Manager (NCM) Pro Software License & Federal Mission Critical Software Support Service for 1 CPU Core
ULT - ULTIMATE	
NT-NCM-ULT-PR	Subscription, Nutanix Cloud Manager (NCM) Ultimate Software License & Production Software Support Service for 1 CPU Core
NT-NCM-ULT-MC	Subscription, Nutanix Cloud Manager (NCM) Ultimate Software License & Mission Critical Software Support Service for 1 CPU Core
NT-NCM-ULT-AP	Subscription, Nutanix Cloud Manager (NCM) Ultimate Software License & L3 Production Software Support Service for 1 CPU Core (Authorized Support Partners provides L1, L2 support)
NT-NCM-ULT-AM	Subscription, Nutanix Cloud Manager (NCM) Ultimate Software License & L3 Mission Critical Software Support Service for 1 CPU Core (Authorized Support Partners provides L1, L2 support)
NT-NCM-ULT-FP	Subscription, Nutanix Cloud Manager (NCM) Ultimate Software License & Federal Production Software Support Service for 1 CPU Core
NT-NCM-ULT-FM	Subscription, Nutanix Cloud Manager (NCM) Ultimate Software License & Federal Mission Critical Software Support Service for 1 CPU Core
COST GOVERNANCE	
NT-NCM-CM-FP	Subscription, NCM Cost Governance as a Service for US Federal including Production Support for 1 VM
NT-NCM-CM-OV-FP	Overage, NCM Cost Governance as a Service for US Federal including Production Support for 1 VM

Table 21.4 Nutanix Cloud Manager (NCM)

NT-NCM-CM-OV-PR	Overage, NCM Cost Governance as a Service including Production Support for 1 VM
NT-NCM-CM-PR	Subscription, NCM Cost Governance as a Service including Production Support for 1 VM
SECURITY CENTRAL	
NT-NCM-SC-FP	Subscription, NCM Security Central as a Service for US Federal including Production Support for 1 VM
NT-NCM-SC-OV-FP	Overage, NCM Security Central as a Service for US Federal including Production Support for 1 VM
NT-NCM-SC-OV-PR	Overage, NCM Security Central as a Service including Production Support for 1 VM
NT-NCM-SC-PR	Subscription, NCM Security Central as a Service including Production Support for 1 VM
SELF SERVICE	
NT-NCM-SS-OV-PR	Overage, NCM Self-Service & Orchestration as a Service including Production Support for 1 VM
NT-NCM-SS-PR	Subscription, NCM Self-Service & Orchestration as a Service including Production Support for 1 VM

Table 26, Nutanix Software NCM STR 1 YEAR AND 3 YEAR & ABOVE SUBSCRIPTION with Professional Services PID Mapping

Table 27, Nutanix Software NCM PRO, NCM ULT, NCP (NCM-PRO), NCP (NCM-ULT) 1 YEAR AND 3 YEAR & ABOVE SUBSCRIPTION with Professional services

(6) Nutanix Cloud Manager Edge (NME):

Nutanix Cloud Manager (NCM) is a hybrid multi-cloud management platform for building a cloud operating model. NCM provides Intelligent Operations, Self-Service, Cost Governance, and Security natively with the Nutanix Platform or through a SaaS subscription.

- Self-service VMs and Apps are defined via simple blueprints, easily created, and managed via GUI/CLI.
- Management of IT lifecycle includes visibility, optimization, and financial control over multi-cloud deployments.
- Detect, monitor, and remediate security vulnerabilities and compliance near real-time across multiple cloud environment.



NOTE:

- For more information Nutanix Cloud Manager (NCM), please visit <https://www.nutanix.com/products/cloud-manager>
- For more information about Nutanix Cloud Platform software options, please visit <https://www.nutanix.com/products/cloud-platform/software-options>
- Please note that the Federal Support program is reserved for US Federal accounts. US Federal accounts must select Federal Support Tier for the order to be fulfilled. If a non-Federal account selects a Federal Support program, Nutanix may not fulfill the order. Additionally, Nutanix's Mixed Support Level Guidelines(<https://www.nutanix.com/support-services/product-support/support-policies-and-faqs?show=accordion-4>) requires all software assets within a cluster to have the same support level, else software support will default to the lower option.
- Sellers in the Federal space need to ensure they have the Federal Support SKU's on the quote and order. All orders without the Federal Support SKU's will be rejected by Nutanix. Refer this Knowledge base article for more info: <https://computekb.cisco.com/article/nutanix-support-for-federal-customers.html>
- PC 2024.2 is the minimum requirement for these licenses to be applied. Check and confirm the release schedule of PC before ordering these licenses.
- Authorized Partners of Nutanix can offer Level 1 & Level 2 support for Nutanix Software. For the complete list visit <https://computekb.cisco.com/article/rules-for-ordering-nutanix-partner-support-skus.html>

Table 21.5 Nutanix Cloud Manager Edge (NME)

Product ID (PID)	PID Description
STR - STARTER	
NT-NME-STR-PR	Subscription, Nutanix Cloud Manager (NCM) Starter Software License for Edge Sites & Production Software Support Service per VM
NT-NME-STR-MC	Subscription, Nutanix Cloud Manager (NCM) Starter Software License for Edge Sites & Mission Critical Software Support Service per VM
NT-NME-STR-AP	Subscription, Nutanix Cloud Manager (NCM) Starter Software License for Edge Sites & L3 Production Software Support Service per VM (Authorized Support Partners provides L1, L2 support)
NT-NME-STR-AM	Subscription, Nutanix Cloud Manager (NCM) Starter Software License for Edge Sites & L3 Mission Critical Software Support Service per VM (Authorized Support Partners provides L1, L2 support)

Table 21.5 Nutanix Cloud Manager Edge (NME)

NT-NME-STR-FP	Subscription, Nutanix Cloud Manager (NCM) Starter Software License for Edge Sites & FED Production Software Support Service per VM
NT-NME-STR-FM	Subscription, Nutanix Cloud Manager (NCM) Starter Software License for Edge Sites & FED Mission Critical Software Support Service per VM
PRO- PROFESSIONAL	
NT-NME-PRO-PR	Subscription, Nutanix Cloud Manager (NCM) Professional Software License for Edge Sites & Production Software Support Service per VM
NT-NME-PRO-MC	Subscription, Nutanix Cloud Manager (NCM) Professional Software License for Edge Sites & Mission Critical Software Support Service per VM
NT-NME-PRO-AP	Subscription, Nutanix Cloud Manager (NCM) Professional Software License for Edge Sites & L3 Production Software Support Service per VM (Authorized Support Partners provides L1, L2 support)
NT-NME-PRO-AM	Subscription, Nutanix Cloud Manager (NCM) Professional Software License for Edge Sites & L3 Mission Critical Software Support Service per VM (Authorized Support Partners provides L1, L2 support)
NT-NME-PRO-FP	Subscription, Nutanix Cloud Manager (NCM) Professional Software License for Edge Sites & FED Production Software Support Service per VM
NT-NME-PRO-FM	Subscription, Nutanix Cloud Manager (NCM) Professional Software License for Edge Sites & FED Mission Critical Software Support Service per VM
ULT - ULTIMATE	
NT-NME-ULT-PR	Subscription, Nutanix Cloud Manager (NCM) Ultimate Software License for Edge Sites & Production Software Support Service per VM
NT-NME-ULT-MC	Subscription, Nutanix Cloud Manager (NCM) Ultimate Software License for Edge Sites & Mission Critical Software Support Service per VM
NT-NME-ULT-AP	Subscription, Nutanix Cloud Manager (NCM) Ultimate Software License for Edge Sites & L3 Production Software Support Service per VM (Authorized Support Partners provides L1, L2 support)
NT-NME-ULT-AM	Subscription, Nutanix Cloud Manager (NCM) Ultimate Software License for Edge Sites & L3 Mission Critical Software Support Service per VM (Authorized Support Partners provides L1, L2 support)
NT-NME-ULT-FP	Subscription, Nutanix Cloud Manager (NCM) Ultimate Software License for Edge Sites & FED Production Software Support Service per VM
NT-NME-ULT-FM	Subscription, Nutanix Cloud Manager (NCM) Ultimate Software License for Edge Sites & FED Mission Critical Software Support Service per VM

[Table 26, Nutanix Software NCM STR 1 YEAR AND 3 YEAR & ABOVE SUBSCRIPTION with Professional Services PID Mapping](#)

[Table 27, Nutanix Software NCM PRO, NCM ULT, NCP \(NCM-PRO\), NCP \(NCM-ULT\) 1 YEAR AND 3 YEAR & ABOVE SUBSCRIPTION with Professional services](#)

(7) Nutanix Cloud Manager EUC (NCM-U):

Nutanix Cloud Manager (NCM) is a hybrid multi-cloud management platform for building a cloud operating model. NCM provides Intelligent Operations, Self-Service, Cost Governance, and Security natively with the Nutanix Platform or through a SaaS subscription.

- Self-service VMs and Apps are defined via simple blueprints, easily created, and managed via GUI/CLI.
- Management of IT lifecycle includes visibility, optimization, and financial control over multi-cloud deployments.
- Detect, monitor, and remediate security vulnerabilities and compliance near real-time across multiple cloud environment.



NOTE:

- For more information Nutanix Cloud Manager (NCM), please visit <https://www.nutanix.com/products/cloud-manager>
- For more information about Nutanix Cloud Platform software options, please visit <https://www.nutanix.com/products/cloud-platform/software-options>
- Please note that the Federal Support program is reserved for US Federal accounts. US Federal accounts must select Federal Support Tier for the order to be fulfilled. If a non-Federal account selects a Federal Support program, Nutanix may not fulfill the order. Additionally, Nutanix's Mixed Support Level Guidelines(<https://www.nutanix.com/support-services/product-support/support-policies-and-faqs?show=accordion-4>) requires all software assets within a cluster to have the same support level, else software support will default to the lower option.
- Sellers in the Federal space need to ensure they have the Federal Support SKU's on the quote and order. All orders without the Federal Support SKU's will be rejected by Nutanix. Refer this Knowledge base article for more info: <https://computekb.cisco.com/article/nutanix-support-for-federal-customers.html>
- PC 2024.2 is the minimum requirement for these licenses to be applied. Check and confirm the release schedule of PC before ordering these licenses.
- Authorized Partners of Nutanix can offer Level 1 & Level 2 support for Nutanix Software. For the complete list visit <https://computekb.cisco.com/article/rules-for-ordering-nutanix-partner-support-skus.html>

Table 21.6 Nutanix Cloud Manager EUC (NCM-U)

Product ID (PID)	PID Description
STR - STARTER	
NT-NCM-U-STR-PR	Subscription, Nutanix Cloud Manager (NCM) Starter Software License for EUC & Production Software Support Service per User
NT-NCM-U-STR-MC	Subscription, Nutanix Cloud Manager (NCM) Starter Software License for EUC & Mission Critical Software Support Service per User
NT-NCM-U-STR-AP	Subscription, Nutanix Cloud Manager (NCM) Starter Software License for EUC & L3 Production Software Support Service per User (Authorized Support Partners provides L1, L2 support)
NT-NCM-U-STR-AM	Subscription, Nutanix Cloud Manager (NCM) Starter Software License for EUC & L3 Mission Critical Software Support Service per User (Authorized Support Partners provides L1, L2 support)
NT-NCM-U-STR-FP	Subscription, Nutanix Cloud Manager (NCM) Starter Software License for EUC & FED Production Software Support Service per User

Table 21.6 Nutanix Cloud Manager EUC (NCM-U)

NT-NCM-U-STR-FM	Subscription, Nutanix Cloud Manager (NCM) Starter Software License for EUC & FED Mission Critical Software Support Service per User
PRO - PROFESSIONAL	
NT-NCM-U-PRO-PR	Subscription, Nutanix Cloud Manager (NCM) Professional Software License for EUC & Production Software Support Service per User
NT-NCM-U-PRO-MC	Subscription, Nutanix Cloud Manager (NCM) Professional Software License for EUC & Mission Critical Software Support Service per User
NT-NCM-U-PRO-AP	Subscription, Nutanix Cloud Manager (NCM) Professional Software License for EUC & L3 Production Software Support Service per User (Authorized Support Partners provides L1, L2 support)
NT-NCM-U-PRO-AM	Subscription, Nutanix Cloud Manager (NCM) Professional Software License for EUC & L3 Mission Critical Software Support Service per User (Authorized Support Partners provides L1, L2 support)
NT-NCM-U-PRO-FP	Subscription, Nutanix Cloud Manager (NCM) Professional Software License for EUC & FED Production Software Support Service per User
NT-NCM-U-PRO-FM	Subscription, Nutanix Cloud Manager (NCM) Professional Software License for EUC & FED Mission Critical Software Support Service per User
ULT - ULTIMATE	
NT-NCM-U-ULT-PR	Subscription, Nutanix Cloud Manager (NCM) Ultimate Software License for EUC & Production Software Support Service per User
NT-NCM-U-ULT-MC	Subscription, Nutanix Cloud Manager (NCM) Ultimate Software License for EUC & Mission Critical Software Support Service per User
NT-NCM-U-ULT-AP	Subscription, Nutanix Cloud Manager (NCM) Ultimate Software License for EUC & L3 Production Software Support Service per User (Authorized Support Partners provides L1, L2 support)
NT-NCM-U-ULT-AM	Subscription, Nutanix Cloud Manager (NCM) Ultimate Software License for EUC & L3 Mission Critical Software Support Service per User (Authorized Support Partners provides L1, L2 support)
NT-NCM-U-ULT-FP	Subscription, Nutanix Cloud Manager (NCM) Ultimate Software License for EUC & FED Production Software Support Service per User
NT-NCM-U-ULT-FM	Subscription, Nutanix Cloud Manager (NCM) Ultimate Software License for EUC & FED Mission Critical Software Support Service per User

Table 26, Nutanix Software NCM STR 1 YEAR AND 3 YEAR & ABOVE SUBSCRIPTION with Professional Services PID Mapping

Table 27, Nutanix Software NCM PRO, NCM ULT, NCP (NCM-PRO), NCP (NCM-ULT) 1 YEAR AND 3 YEAR & ABOVE SUBSCRIPTION with Professional services

(8) Nutanix Cloud Platform (NCP)

Nutanix Cloud Infrastructure (NCI) and Nutanix Cloud Manager (NCM) can be purchased together in ‘better together’ Nutanix Cloud Platform (NCP) bundles:

Nutanix Cloud Platform (NCP)	Nutanix Cloud Infrastructure (NCI) Included	Nutanix Cloud Manager (NCM) Edition included
NCP Starter	NCI Professional	NCM Professional
NCP Professional	NCI Ultimate	NCM Professional
NCP Ultimate	NCI Ultimate	NCM Ultimate



NOTE:

- For more information on Nutanix Cloud Platform (NCP) bundles, please visit <https://www.nutanix.com/products/cloud-platform/software-options>
- For more information about Nutanix Cloud Platform software options, please visit <https://www.nutanix.com/products/cloud-platform/software-options>
- Please note that the Federal Support program is reserved for US Federal accounts. US Federal accounts must select Federal Support Tier for the order to be fulfilled. If a non-Federal account selects a Federal Support program, Nutanix may not fulfill the order. Additionally, Nutanix’s Mixed Support Level Guidelines (<https://www.nutanix.com/support-services/product-support/support-policies-and-faqs?show=accordion-4>) requires all software assets within a cluster to have the same support level, else software support will default to the lower option.
- Sellers in the Federal space need to ensure they have the Federal Support SKU’s on the quote and order. All orders without the Federal Support SKU’s will be rejected by Nutanix. Refer this Knowledge base article for more info: <https://computekb.cisco.com/article/nutanix-support-for-federal-customers.html>
- Authorized Partners of Nutanix can offer Level 1 & Level 2 support for Nutanix Software. For the complete list visit <https://computekb.cisco.com/article/rules-for-ordering-nutanix-partner-support-skus.html>
- The total number of cores for NCI and NCM should be same as NCP
- The support tiers for NCI and NCM should be same as NCP

Table 21.7 Nutanix Cloud Platform (NCP)

Product ID (PID)	PID Description
NCP STR - STARTER	
NT-NCP-STR-PR	Subscription, Nutanix Cloud Platform Starter Software License & Production Software Support Service for 1 CPU Core
NT-NCP-STR-MC	Subscription, Nutanix Cloud Platform Starter Software License & Mission Critical Software Support Service for 1 CPU Core
NT-NCP-STR-AP	Subscription, Nutanix Cloud Platform Starter Software License & L3 Production Software Support Service for 1 CPU Core (Authorized Support Partners provides L1, L2 support)

Table 21.7 Nutanix Cloud Platform (NCP)

NT-NCP-STR-AM	Subscription, Nutanix Cloud Platform Starter Software License & L3 Mission Critical Software Support Service for 1 CPU Core (Authorized Support Partners provides L1, L2 support)
NT-NCP-STR-FP	Subscription, Nutanix Cloud Platform Starter Software License & Federal Production Software Support Service for 1 CPU Core
NT-NCP-STR-FM	Subscription, Nutanix Cloud Platform Starter Software License & Federal Mission Critical Software Support Service for 1 CPU Core
NCP PRO- PROFESSIONAL	
NT-NCP-PRO-PR	Subscription, Nutanix Cloud Platform Pro Software License & Production Software Support Service for 1 CPU Core
NT-NCP-PRO-MC	Subscription, Nutanix Cloud Platform Pro Software License & Mission Critical Software Support Service for 1 CPU Core
NT-NCP-PRO-AP	Subscription, Nutanix Cloud Platform Pro Software License & L3 Production Software Support Service for 1 CPU Core (Authorized Support Partners provides L1, L2 support)
NT-NCP-PRO-AM	Subscription, Nutanix Cloud Platform Pro Software License & L3 Mission Critical Software Support Service for 1 CPU Core (Authorized Support Partners provides L1, L2 support)
NT-NCP-PRO-FP	Subscription, Nutanix Cloud Platform Pro Software License & Federal Production Software Support Service for 1 CPU Core
NT-NCP-PRO-FM	Subscription, Nutanix Cloud Platform Pro Software License & Federal Mission Critical Software Support Service for 1 CPU Core
NCP ULT-ULTIMATE	
NT-NCP-ULT-PR	Subscription, Nutanix Cloud Platform Ultimate Software License & Production Software Support Service for 1 CPU Core
NT-NCP-ULT-MC	Subscription, Nutanix Cloud Platform Ultimate Software License & Mission Critical Software Support Service for 1 CPU Core
NT-NCP-ULT-AP	Subscription, Nutanix Cloud Platform Ultimate Software License & L3 Production Software Support Service for 1 CPU Core (Authorized Support Partners provides L1, L2 support)
NT-NCP-ULT-AM	Subscription, Nutanix Cloud Platform Ultimate Software License & L3 Mission Critical Software Support Service for 1 CPU Core (Authorized Support Partners provides L1, L2 support)
NT-NCP-ULT-FP	Subscription, Nutanix Cloud Platform Ultimate Software License & Federal Production Software Support Service for 1 CPU Core
NT-NCP-ULT-FM	Subscription, Nutanix Cloud Platform Ultimate Software License & Federal Mission Critical Software Support Service for 1 CPU Core
NCI PROFESSIONAL	
NT-NCP-NCI-PRO-PR	Subscription, (included in NCP) Nutanix Cloud Infrastructure (NCI) Pro Software License & Production Software Support Service for 1 CPU Core

Table 21.7 Nutanix Cloud Platform (NCP)

NT-NCP-NCI-PRO-MC	Subscription, (included in NCP) Nutanix Cloud Infrastructure (NCI) Pro Software License & Mission Critical Software Support Service for 1 CPU Core
NT-NCP-NCI-PRO-AP	Subscription, (included in NCP) Nutanix Cloud Infrastructure (NCI) Pro Software License & L3 Production Software Support Service for 1 CPU Core (Authorized Support Partners provides L1, L2 support)
NT-NCP-NCI-PRO-AM	Subscription, (included in NCP) Nutanix Cloud Infrastructure (NCI) Pro Software License & L3 Mission Critical Software Support Service for 1 CPU Core (Authorized Support Partners provides L1, L2 support)
NT-NCP-NCI-PRO-FP	Subscription, (included in NCP) Nutanix Cloud Infrastructure (NCI) Pro Software License & Federal Production Software Support Service for 1 CPU Core
NT-NCP-NCI-PRO-FM	Subscription, (included in NCP) Nutanix Cloud Infrastructure (NCI) Pro Software License & Federal Mission Critical Software Support Service for 1 CPU Core
NCI ULTIMATE	
NT-NCP-NCI-ULT-PR	Subscription, (included in NCP) Nutanix Cloud Infrastructure (NCI) Ultimate Software License & Production Software Support Service for 1 CPU Core
NT-NCP-NCI-ULT-MC	Subscription, (included in NCP) Nutanix Cloud Infrastructure (NCI) Ultimate Software License & Mission Critical Software Support Service for 1 CPU Core
NT-NCP-NCI-ULT-AP	Subscription, (included in NCP) Nutanix Cloud Infrastructure (NCI) Ultimate Software License & L3 Production Software Support Service for 1 CPU Core (Authorized Support Partners provides L1, L2 support)
NT-NCP-NCI-ULT-AM	Subscription, (included in NCP) Nutanix Cloud Infrastructure (NCI) Ultimate Software License & L3 Mission Critical Software Support Service for 1 CPU Core (Authorized Support Partners provides L1, L2 support)
NT-NCP-NCI-ULT-FP	Subscription, (included in NCP) Nutanix Cloud Infrastructure (NCI) Ultimate Software License & Federal Production Software Support Service for 1 CPU Core
NT-NCP-NCI-ULT-FM	Subscription, (included in NCP) Nutanix Cloud Infrastructure (NCI) Ultimate Software License & Federal Mission Critical Software Support Service for 1 CPU Core
NCM PROFESSIONAL	
NT-NCP-NCM-PRO-PR	Subscription, (included in NCP) Nutanix Cloud Manager (NCM) Pro Software License & Production Software Support Service for 1 CPU Core
NT-NCP-NCM-PRO-MC	Subscription, (included in NCP) Nutanix Cloud Manager (NCM) Pro Software License & Mission Critical Software Support Service for 1 CPU Core
NT-NCP-NCM-PRO-AP	Subscription, (included in NCP) Nutanix Cloud Manager (NCM) Pro Software License & L3 Production Software Support Service for 1 CPU Core (Authorized Support Partners provides L1, L2 support)
NT-NCP-NCM-PRO-AM	Subscription, (included in NCP) Nutanix Cloud Manager (NCM) Pro Software License & L3 Mission Critical Software Support Service for 1 CPU Core (Authorized Support Partners provides L1, L2 support)
NT-NCP-NCM-PRO-FP	Subscription, (included in NCP) Nutanix Cloud Manager (NCM) Pro Software License & Federal Production Software Support Service for 1 CPU Core

Table 21.7 Nutanix Cloud Platform (NCP)

NT-NCP-NCM-PRO-FM	Subscription, (included in NCP) Nutanix Cloud Manager (NCM) Pro Software License & Federal Mission Critical Software Support Service for 1 CPU Core
NCM ULTIMATE	
NT-NCP-NCM-ULT-PR	Subscription, (included in NCP) Nutanix Cloud Manager (NCM) Ultimate Software License & Production Software Support Service for 1 CPU Core
NT-NCP-NCM-ULT-MC	Subscription, (included in NCP) Nutanix Cloud Manager (NCM) Ultimate Software License & Mission Critical Software Support Service for 1 CPU Core
NT-NCP-NCM-ULT-AP	Subscription, (included in NCP) Nutanix Cloud Manager (NCM) Ultimate Software License & L3 Production Software Support Service for 1 CPU Core (Authorized Support Partners provides L1, L2 support)
NT-NCP-NCM-ULT-AM	Subscription, (included in NCP) Nutanix Cloud Manager (NCM) Ultimate Software License & L3 Mission Critical Software Support Service for 1 CPU Core (Authorized Support Partners provides L1, L2 support)
NT-NCP-NCM-ULT-FP	Subscription, (included in NCP) Nutanix Cloud Manager (NCM) Ultimate Software License & Federal Production Software Support Service for 1 CPU Core
NT-NCP-NCM-ULT-FM	Subscription, (included in NCP) Nutanix Cloud Manager (NCM) Ultimate Software License & Federal Mission Critical Software Support Service for 1 CPU Core

[Table 26, Nutanix Software NCM STR 1 YEAR AND 3 YEAR & ABOVE SUBSCRIPTION with Professional Services PID Mapping](#)

[Table 27, Nutanix Software NCM PRO, NCM ULT, NCP \(NCM-PRO\), NCP \(NCM-ULT\) 1 YEAR AND 3 YEAR & ABOVE SUBSCRIPTION with Professional services](#)

(9) Nutanix Unified Storage™ (NUS):

Nutanix Unified Storage™ (NUS) is a software-defined data services platform that consolidates the management and protection of siloed block, file, and object storage into a single, unified platform. NUS harnesses the power of rich data services such as analytics, ransomware protection, lifecycle management, and data protection. These features enable organizations to seamlessly adapt to the ever-changing requirements of modern applications, allowing them to shift their management focus from data storage to data management. Leveraging the Nutanix Cloud Platform™ (NCP) software, NUS is specifically built to meet the needs of modern applications deployed across core, cloud, and edge infrastructure. With its capacity for seamless scaling, high performance, and integrated data security, NUS provides a comprehensive solution for organizations.

Includes:

- **Nutanix Files Storage:** simple and secure software-defined scale-out file storage solution to store, manage, and scale files data (NFS and SMB)
- **Nutanix Objects Storage:** distributed scale-out S3-compatible object storage for both archive and high-performance analytics
- **Nutanix Volumes Storage:** high-performance low-latency block storage
- **Nutanix Data Lens:** available as an add-on for data analytics, anomaly behavior detection and ransomware protection
- **Nutanix AOS:** scale-out storage technology that makes hyperconverged infrastructure (HCI) possible.
- **Nutanix AHV:** lightweight cloud hypervisor built into Nutanix platform and offers enterprise-grade storage capabilities and built-in Kubernetes support.
- **App VMs running on storage:** NUS dedicated clusters are entitled to 1 app/user VM per node in the cluster. NCI clusters don't have any limit on the number of app/user VMs on the cluster.

**NOTE:**

- For more information **Nutanix Unified Storage™ (NUS)**, please visit <https://www.nutanix.com/products/cloud-platform/software-options#nus>
 - For more information about Nutanix Cloud Platform software options, please visit <https://www.nutanix.com/products/cloud-platform/software-options>
 - Please note that the Federal Support program is reserved for US Federal accounts. US Federal accounts must select Federal Support Tier for the order to be fulfilled. If a non-Federal account selects a Federal Support program, Nutanix may not fulfill the order. Additionally, Nutanix's Mixed Support Level Guidelines(<https://www.nutanix.com/support-services/product-support/support-policies-and-faqs?show=accordion-4>) requires all software assets within a cluster to have the same support level, else software support will default to the lower option.
 - Sellers in the Federal space need to ensure they have the Federal Support SKU's on the quote and order. All orders without the Federal Support SKU's will be rejected by Nutanix. Refer this Knowledge base article for more info: <https://compute.kb.cisco.com/article/nutanix-support-for-federal-customers.html>
 - Authorized Partners of Nutanix can offer Level 1 & Level 2 support for Nutanix Software. For the complete list visit <https://compute.kb.cisco.com/article/rules-for-ordering-nutanix-partner-support-skus.html>
-

Table 21.8 Nutanix Unified Storage™ (NUS)

Product ID (PID)	PID Description
PRO - PROFESSIONAL	
NT-NUS-PRO-PR	Nutanix Unified Storage Professional Software License & Production Software Support for 1 TiB
NT-NUS-PRO-MC	Nutanix Unified Storage Professional Software License & Mission Critical Software Support for 1 TiB
NT-NUS-PRO-AP	Nutanix Unified Storage Professional Software License & L3 Production Software Support for 1 TiB (Authorized Support Partners provides L1, L2 support)
NT-NUS-PRO-AM	Nutanix Unified Storage Professional Software License & L3 Mission Critical Software Support for 1 TiB (Authorized Support Partners provides L1, L2 support)
NT-NUS-PRO-FP	Nutanix Unified Storage Professional Software License & Federal Production Software Support for 1 TiB
NT-NUS-PRO-FM	Nutanix Unified Storage Professional Software License & Federal Mission Critical Software Support for 1 TiB
ADVANCED REPLICATION	
NT-A-NUS-ADR-PR	Nutanix Unified Storage Advanced Replication add-on Software License & Production Software Support 1 TiB
NT-A-NUS-ADR-MC	Nutanix Unified Storage Advanced Replication add-on Software License & Mission Critical Software Support 1 TiB
NT-A-NUS-ADR-AP	Nutanix Unified Storage Advanced Replication add-on Software License & L3 Production Software Support 1 TiB (Authorized Support Partners provides L1, L2 support)
NT-A-NUS-ADR-AM	Nutanix Unified Storage Advanced Replication add-on Software License & L3 Mission Critical Software Support 1 TiB (Authorized Support Partners provides L1, L2 support)
NT-A-NUS-ADR-FP	Nutanix Unified Storage Advanced Replication add-on Software License & Federal Production Software Support 1 TiB
NT-A-NUS-ADR-FM	Nutanix Unified Storage Advanced Replication add-on Software License & Federal Mission Critical Support 1 TiB
SECURITY	
NT-A-NUS-SEC-PR	Nutanix Unified Storage Security add-on Software License & Production Software Support 1 TiB
NT-A-NUS-SEC-MC	Nutanix Unified Storage Security add-on Software License & Mission Critical Software Support 1 TiB
NT-A-NUS-SEC-AP	Nutanix Unified Storage Security add-on Software License & L3 Production Software Support 1 TiB (Authorized Support Partners provides L1, L2 support)
NT-A-NUS-SEC-AM	Nutanix Unified Storage Security add-on Software License & L3 Mission Critical Software Support 1 TiB (Authorized Support Partners provides L1, L2 support)

Table 21.8 Nutanix Unified Storage™ (NUS)

NT-A-NUS-SEC-FP	Nutanix Unified Storage Security add-on Software License & Federal Production Software Support 1 TiB
NT-A-NUS-SEC-FM	Nutanix Unified Storage Security add-on Software License & Federal Mission Critical Software Support 1 TiB

Nutanix Unified Storage Allowed Capacity

Nutanix Unified Storage	Nutanix Unified Storage Support Tier	Storage Capacity Allowed (TiB)
Pro (Professional) License Tier (NT-NUS-PRO-*) Advanced Replication (NT-A-NUS-ADR-*) Security (NT-A-NUS-SEC-*)	Production Mission Critical Federal Production Federal Mission Critical	1-50
		75
		100
		150
		200
		250
		300
		350
		400
		450
		500
		550
		600
		700
		800
		900
		1000
		1200
		1400
		1600
1800		
2000		
2200		
2400		
2600		
2800		
3000		
4000		
5000		
6000		
7000		
8000		
9000		
10000		

(10) Nutanix Data Lens (NDL):

Nutanix Data Lens is a SaaS-based cyberstorage solution offering ransomware resilience and global data visibility for unstructured data on Nutanix Unified Storage (NUS). This cloud-based data analytics service proactively assesses and mitigates data security risks by identifying anomalous activity, auditing user behavior, and adhering to compliance requirements. while enabling efficient data lifecycle management.

Nutanix Data Lens is currently offered through a “Freemium” licensing model, consisting of two tiers:

1. “Basic Tier” comprises limited capabilities that are available perpetually free for NUS Pro customers
2. “Premium Tier” comprises extended capabilities, including Ransomware security, and is licensed on a per TiB basis for all NUS customers.

Self-service onboarding for current Nutanix Unified Storage Customers through [My Nutanix Portal](#).



NOTE:

- For more information **Nutanix Data Lens (NDL)**, please visit <https://www.nutanix.com/products/cloud-platform/software-options#nus>
- For more information about Nutanix Cloud Platform software options, please visit <https://www.nutanix.com/products/cloud-platform/software-options>
- Please note that the Federal Support program is reserved for US Federal accounts. US Federal accounts must select Federal Support Tier for the order to be fulfilled. If a non-Federal account selects a Federal Support program, Nutanix may not fulfill the order. Additionally, Nutanix's Mixed Support Level Guidelines(<https://www.nutanix.com/support-services/product-support/support-policies-and-faqs?show=accordion-4>) requires all software assets within a cluster to have the same support level, else software support will default to the lower option.
- Sellers in the Federal space need to ensure they have the Federal Support SKU's on the quote and order. All orders without the Federal Support SKU's will be rejected by Nutanix.Refer this Knowledge base article for more info: <https://compute.kb.cisco.com/article/nutanix-support-for-federal-customers.html>
- Authorized Partners of Nutanix can offer Level 1 & Level 2 support for Nutanix Software. For the complete list visit <https://compute.kb.cisco.com/article/rules-for-ordering-nutanix-partner-support-skus.html>

Table 21.9 Nutanix Data Lens (NDL)

Product ID (PID)	PID Description
NDL	
NT-NDL-PR	Nutanix Data Lens as a hosted service including Production Support for 1 TiB
NT-NDL-FP	Nutanix Data Lens as a hosted service incl Fed Production Support for 1 TiB

Nutanix Data Lens Allowed Capacity

Nutanix Data Lens	Nutanix Data Lens Support Tier	Storage Capacity Allowed (TiB)
NDL	Production Federal Production	1-50
		75
		100
		150
		200
		250
		300
		350
		400
		450
		500
		550
		600
		700
		800
		900
		1000
		1200
		1400
		1600
1800		
2000		
2200		
2400		
2600		
2800		
3000		

(11) Nutanix Kubernetes Platform (NKP):

Nutanix Kubernetes Platform (NKP) combines the Nutanix Kubernetes Engine (NKE) features with their acquisition of the D2iQ product family to bring a consolidated runtime, orchestration, and management environment to our cloud native customers. The SKUs have two ordering options:

1. NKP Full Stack (Starter, Pro & Ultimate) - This includes the Complete Nutanix stack, bundling NCI, NDK and NKP. This is core based licensing (for all cores in cluster) and feature/capability inclusions depend on the whether it's starter, Pro or Ultimate. This is suitable for customers who will have Nutanix clusters exclusively for container workloads.
2. NKP (Pro & Ultimate) - NKP Starter is Bundled with NCI Pro and Ultimate . This adds NKP to existing NCI deployments (for AHV, ESXi, AWS EC2 & Azure). The Kubernetes and associated NKP functionality is provided by running master and worker node VMs on NCI. This is licensed on vCPU for the workload VMs that will be deployed. This is suitable for customers who already have Nutanix NCI clusters.



NOTE:

- For more information about Nutanix Kubernetes Platform (NKP), please visit <https://www.nutanix.com/products/cloud-platform/software-options#nkp>
- For more information about Nutanix Cloud Platform software options, please visit <https://www.nutanix.com/products/cloud-platform/software-options>
- Please note that the Federal Support program is reserved for US Federal accounts. US Federal accounts must select Federal Support Tier for the order to be fulfilled. If a non-Federal account selects a Federal Support program, Nutanix may not fulfill the order. Additionally, Nutanix's Mixed Support Level Guidelines(<https://www.nutanix.com/support-services/product-support/support-policies-and-faqs?show=accordion-4>) requires all software assets within a cluster to have the same support level, else software support will default to the lower option.
- Sellers in the Federal space need to ensure they have the Federal Support SKU's on the quote and order. All orders without the Federal Support SKU's will be rejected by Nutanix.Refer this Knowledge base article for more info: <https://computekb.cisco.com/article/nutanix-support-for-federal-customers.html>
- Authorized Partners of Nutanix can offer Level 1 & Level 2 support for Nutanix Software. For the complete list visit <https://computekb.cisco.com/article/rules-for-ordering-nutanix-partner-support-skus.html>
- The quantity of NKP Full Stack (FS) license must match with total number for processor cores in hardware platforms.

Table 21.10 Nutanix Kubernetes Platform (NKP)

Product ID (PID)	PID Description
FS STR - FULL STACK STARTER	
NT-NKP-FS-STR-PR	Subscription, Nutanix Kubernetes Platform (NKP) Full Stack Starter Software License and Production Software Support Service for 1 CPU Core
NT-NKP-FS-STR-MC	Subscription, Nutanix Kubernetes Platform (NKP) Full Stack Starter Software License and Mission Critical Software Support Service for 1 CPU Core
NT-NKP-FS-STR-AP	Subscription, Nutanix Kubernetes Platform (NKP) Full Stack Starter Software License and L3 Production Software Support Service for 1 CPU Core (Authorized Support Partners provides L1, L2 support)
NT-NKP-FS-STR-AM	Subscription, Nutanix Kubernetes Platform (NKP) Full Stack Starter Software License and L3 Mission Critical Software Support Service for 1 CPU Core (Authorized Support Partners provides L1, L2 support)

Table 21.10 Nutanix Kubernetes Platform (NKP)

NT-NKP-FS-STR-FP	Subscription, Nutanix Kubernetes Platform (NKP) Full Stack Starter Software License and Federal Production Software Support Service for 1 CPU Core
NT-NKP-FS-STR-FM	Subscription, Nutanix Kubernetes Platform (NKP) Full Stack Starter Software License and Federal Mission Critical Software Support Service for 1 CPU Core
FS PRO - FULL STACK PROFESSIONAL	
NT-NKP-FS-PRO-PR	Subscription, Nutanix Kubernetes Platform (NKP) Full Stack Pro Software License and Production Software Support Service for 1 CPU Core
NT-NKP-FS-PRO-MC	Subscription, Nutanix Kubernetes Platform (NKP) Full Stack Pro Software License and Mission Critical Software Support Service for 1 CPU Core
NT-NKP-FS-PRO-AP	Subscription, Nutanix Kubernetes Platform (NKP) Full Stack Pro Software License and L3 Production Software Support Service for 1 CPU Core (Authorized Support Partners provides L1, L2 support)
NT-NKP-FS-PRO-AM	Subscription, Nutanix Kubernetes Platform (NKP) Full Stack Pro Software License and L3 Mission Critical Software Support Service for 1 CPU Core (Authorized Support Partners provides L1, L2 support)
NT-NKP-FS-PRO-FP	Subscription, Nutanix Kubernetes Platform (NKP) Full Stack Pro Software License and Federal Production Software Support Service for 1 CPU Core
NT-NKP-FS-PRO-FM	Subscription, Nutanix Kubernetes Platform (NKP) Full Stack Pro Software License and Federal Mission Critical Software Support Service for 1 CPU Core
FS ULT - FULL STACK ULTIMATE	
NT-NKP-FS-ULT-PR	Subscription, Nutanix Kubernetes Platform (NKP) Full Stack Ultimate Software License and Production Software Support Service for 1 CPU Core
NT-NKP-FS-ULT-MC	Subscription, Nutanix Kubernetes Platform (NKP) Full Stack Ultimate Software License and Mission Critical Software Support Service for 1 CPU Core
NT-NKP-FS-ULT-AP	Subscription, Nutanix Kubernetes Platform (NKP) Full Stack Ultimate Software License and L3 Production Software Support Service for 1 CPU Core (Authorized Support Partners provides L1, L2 support)
NT-NKP-FS-ULT-AM	Subscription, Nutanix Kubernetes Platform (NKP) Full Stack Ultimate Software License and L3 Mission Critical Software Support Service for 1 CPU Core (Authorized Support Partners provides L1, L2 support)
NT-NKP-FS-ULT-FP	Subscription, Nutanix Kubernetes Platform (NKP) Full Stack Ultimate Software License and Federal Production Software Support Service for 1 CPU Core
NT-NKP-FS-ULT-FM	Subscription, Nutanix Kubernetes Platform (NKP) Full Stack Ultimate Software License and Federal Mission Critical Software Support Service for 1 CPU Core
PRO - PROFESSIONAL	
NT-NKP-PRO-PR	Subscription, Nutanix Kubernetes Platform (NKP) Pro Software License for NCI or non-Nutanix infrastructure and Production Software Support Service for 1 vCPU (or 1 CPU Core on bare metal)

Table 21.10 Nutanix Kubernetes Platform (NKP)

NT-NKP-PRO-MC	Subscription, Nutanix Kubernetes Platform (NKP) Pro Software License for NCI or non-Nutanix infrastructure and Mission Critical Software Support Service for 1 vCPU (or 1 CPU Core on bare metal)
NT-NKP-PRO-AP	Subscription, Nutanix Kubernetes Platform (NKP) Pro Software License for NCI or non-Nutanix infrastructure and L3 Production Software Support Service for 1 vCPU (or 1 CPU Core on bare metal) (Authorized Support Partners provides L1, L2 support)
NT-NKP-PRO-AM	Subscription, Nutanix Kubernetes Platform (NKP) Pro Software License for NCI or non-Nutanix infrastructure and L3 Mission Critical Software Support Service for 1 vCPU (or 1 CPU Core on bare metal) (Authorized Support Partners provides L1, L2 support)
NT-NKP-PRO-FP	Subscription, Nutanix Kubernetes Platform (NKP) Pro Software License for NCI or non-Nutanix infrastructure and Federal Production Software Support Service for 1 vCPU (or 1 CPU Core on bare metal)
NT-NKP-PRO-FM	Subscription, Nutanix Kubernetes Platform (NKP) Pro Software License for NCI or non-Nutanix infrastructure and Federal Mission Critical Software Support Service for 1 vCPU (or 1 CPU Core on bare metal)
ULT - ULTIMATE	
NT-NKP-ULT-PR	Subscription, Nutanix Kubernetes Platform (NKP) Ultimate Software License for NCI or non-Nutanix infrastructure and Production Software Support Service for 1 vCPU (or 1 CPU Core on bare metal)
NT-NKP-ULT-MC	Subscription, Nutanix Kubernetes Platform (NKP) Ultimate Software License for NCI or non-Nutanix infrastructure and Mission Critical Software Support Service for 1 vCPU (or 1 CPU Core on bare metal)
NT-NKP-ULT-AP	Subscription, Nutanix Kubernetes Platform (NKP) Ultimate Software License for NCI or non-Nutanix infrastructure and L3 Production Software Support Service for 1 vCPU (or 1 CPU Core on bare metal) (Authorized Support Partners provides L1, L2 support)
NT-NKP-ULT-AM	Subscription, Nutanix Kubernetes Platform (NKP) Ultimate Software License for NCI or non-Nutanix infrastructure and L3 Mission Critical Software Support Service for 1 vCPU (or 1 CPU Core on bare metal) (Authorized Support Partners provides L1, L2 support)
NT-NKP-ULT-FP	Subscription, Nutanix Kubernetes Platform (NKP) Ultimate Software License for NCI or non-Nutanix infrastructure and Federal Production Software Support Service for 1 vCPU (or 1 CPU Core on bare metal)
NT-NKP-ULT-FM	Subscription, Nutanix Kubernetes Platform (NKP) Ultimate Software License for NCI or non-Nutanix infrastructure and Federal Mission Critical Software Support Service for 1 vCPU (or 1 CPU Core on bare metal)

[Table 25.0, Nutanix Software NCI, NCI-D, NCP \(NCI-PRO\), NCP \(NCI-ULT\), 1 YEAR SUBSCRIPTION with professional services PID Mapping](#)

[Table 25.1, Nutanix Software NCI, NCI-D, NCP \(NCI-PRO\), NCP \(NCI-ULT\), 3 YEAR SUBSCRIPTION with professional services PID Mapping](#)

(12) Nutanix Enterprise AI (NAI):

The Nutanix Enterprise AI (NAI) solution offers endpoint APIs for the leading LLM providers, including NVIDIA NIM and Hugging Face, making it easy for organizations to deploy a wide range of GenAI models securely, on-premises or in the public cloud. NAI includes a simple UI, role-based access controls (RBAC), and the capability for untethered operations (dark site or air-gapped deployments) to simplify the operation, monitoring, and adaptation of AI models (LLMs) with enterprise resiliency, Day 2 operations, and compliance.

Nutanix AI Platform has 2 ordering requirements & both need to be ordered:

- CPU (measured in vCPU/Core): This quantity should correspond to the number of physical cores for bare-metal deployments or the vCPUs for virtual deployments.
- GB (memory on GPU): Note that this refers to the total GPU memory, not the physical memory of the nodes in the cluster, and it depends on the GPU selected.



NOTE:

- For more information about Nutanix Enterprise AI (NAI), please visit <https://www.nutanix.com/library/datasheets/nutanix-enterprise-ai>
- For more information about Nutanix Cloud Platform software options, please visit <https://www.nutanix.com/products/cloud-platform/software-options>
- Please note that the Federal Support program is reserved for US Federal accounts. US Federal accounts must select Federal Support Tier for the order to be fulfilled. If a non-Federal account selects a Federal Support program, Nutanix may not fulfill the order. Additionally, Nutanix's Mixed Support Level Guidelines(<https://www.nutanix.com/support-services/product-support/support-policies-and-faqs?show=accordion-4>) requires all software assets within a cluster to have the same support level, else software support will default to the lower option.
- Sellers in the Federal space need to ensure they have the Federal Support SKU's on the quote and order. All orders without the Federal Support SKU's will be rejected by Nutanix. Refer this Knowledge base article for more info: <https://computekb.cisco.com/article/nutanix-support-for-federal-customers.html>
- Authorized Partners of Nutanix can offer Level 1 & Level 2 support for Nutanix Software. For the complete list visit <https://computekb.cisco.com/article/rules-for-ordering-nutanix-partner-support-skus.html>

Table 21.11 Nutanix Enterprise AI (NAI)

Product ID (PID)	PID Description
PROFESSIONAL LICENSE FOR GPU	
NT-AI-PRO-GB-PR	Subscription, Nutanix Enterprise AI (NAI) Pro Software License and Production Software Support Service for 1 GB of GPU RAM
NT-AI-PRO-GB-MC	Subscription, Nutanix Enterprise AI (NAI) Pro Software License and Mission Critical Software Support Service for 1 GB of GPU RAM
NT-AI-PRO-GB-AP	Subscription, Nutanix Enterprise AI (NAI) Pro Software License and L3 Production Software Support Service for 1 GB of GPU RAM (Authorized Service Provider provides L1, L2 support)
NT-AI-PRO-GB-AM	Subscription, Nutanix Enterprise AI (NAI) Pro Software License and L3 Mission Critical Software Support Service for 1 GB of GPU RAM (Authorized Service Provider provides L1, L2 support)

Table 21.11 Nutanix Enterprise AI (NAI)

NT-AI-PRO-GB-FP	Subscription, Nutanix Enterprise AI (NAI) Pro Software License and Federal Production Software Support Service for 1 GB of GPU RAM
NT-AI-PRO-GB-FM	Subscription, Nutanix Enterprise AI (NAI) Pro Software License and Federal Mission Critical Software Support Service for 1 GB of GPU RAM
PROFESSIONAL LICENSE FOR CORE or vCPU	
NT-AI-PRO-C-PR	Subscription, Nutanix Enterprise AI (NAI) Pro Software License and Production Software Support Service for 1 vCPU
NT-AI-PRO-C-MC	Subscription, Nutanix Enterprise AI (NAI) Pro Software License and Mission Critical Software Support Service for 1 vCPU
NT-AI-PRO-C-AP	Subscription, Nutanix Enterprise AI (NAI) Pro Software License and L3 Production Software Support Service for 1 vCPU (Authorized Service Provider provides L1, L2 support)
NT-AI-PRO-C-AM	Subscription, Nutanix Enterprise AI (NAI) Pro Software License and L3 Mission Critical Software Support Service for 1 vCPU (Authorized Service Provider provides L1, L2 support)
NT-AI-PRO-C-FP	Subscription, Nutanix Enterprise AI (NAI) Pro Software License and Federal Production Software Support Service for 1 vCPU
NT-AI-PRO-C-FM	Subscription, Nutanix Enterprise AI (NAI) Pro Software License and Federal Mission Critical Software Support Service for 1 vCPU
PROFESSIONAL GPT	
NT-AI-GPT-PO-C-PR	Subscription, Nutanix Enterprise AI (NAI) GPT-in-a-box Pro Software License & Production Software Support Service for 1 CPU Core
NT-AI-GPT-PO-C-MC	Subscription, Nutanix Enterprise AI (NAI) GPT-in-a-box Pro Software License & Mission Critical Software Support Service for 1 CPU Core
NT-AI-GPT-PO-C-AP	Subscription, Nutanix Enterprise AI (NAI) GPT-in-a-box Pro Software License & L3 Production Software Support Service for 1 CPU Core (Authorized Service Provider provides L1, L2 support)
NT-AI-GPT-PO-C-AM	Subscription, Nutanix Enterprise AI (NAI) GPT-in-a-box Pro Software License & L3 Mission Critical Software Support Service for 1 CPU Core (Authorized Service Provider provides L1, L2 support)
NT-AI-GPT-PO-C-FP	Subscription, Nutanix Enterprise AI (NAI) GPT-in-a-box Pro Software License & Federal Production Software Support Service for 1 CPU Core
NT-AI-GPT-PO-C-FM	Subscription, Nutanix Enterprise AI (NAI) GPT-in-a-box Pro Software License & Federal Mission Critical Software Support Service for 1 CPU Core
ULTIMATE GPT	
NT-AI-GPT-UT-C-PR	Subscription, Nutanix Enterprise AI (NAI) GPT-in-a-box Ultimate Software License & Production Software Support Service for 1 CPU Core
NT-AI-GPT-UT-C-MC	Subscription, Nutanix Enterprise AI (NAI) GPT-in-a-box Ultimate Software License & Mission Critical Software Support Service for 1 CPU Core

Table 21.11 Nutanix Enterprise AI (NAI)

NT-AI-GPT-UT-C-AP	Subscription, Nutanix Enterprise AI (NAI) GPT-in-a-box Ultimate Software License & L3 Production Software Support Service for 1 CPU Core (Authorized Service Provider provides L1, L2 support)
NT-AI-GPT-UT-C-AM	Subscription, Nutanix Enterprise AI (NAI) GPT-in-a-box Ultimate Software License & L3 Mission Critical Software Support Service for 1 CPU Core (Authorized Service Provider provides L1, L2 support)
NT-AI-GPT-UT-C-FP	Subscription, Nutanix Enterprise AI (NAI) GPT-in-a-box Ultimate Software License & Federal Production Software Support Service for 1 CPU Core
NT-AI-GPT-UT-C-FM	Subscription, Nutanix Enterprise AI (NAI) GPT-in-a-box Ultimate Software License & Federal Mission Critical Software Support Service for 1 CPU Core
NAI NKP PROFESSIONAL	
NT-AI-NKP-PO-C-PR	Subscription, Nutanix Enterprise AI (NAI) Pro and Nutanix Kubernetes Platform (NKP) Pro Software License & Production Software Support Service for 1 vCPU or 1 physical CPU Core
NT-AI-NKP-PO-C-MC	Subscription, Nutanix Enterprise AI (NAI) Pro and Nutanix Kubernetes Platform (NKP) Pro Software License & Mission Critical Software Support Service for 1 vCPU or 1 physical CPU Core
NT-AI-NKP-PO-C-AP	Subscription, Nutanix Enterprise AI (NAI) Pro and Nutanix Kubernetes Platform (NKP) Pro Software License & L3 Production Software Support Service for 1 vCPU or 1 physical CPU Core (Authorized Service Provider provides L1, L2 support)
NT-AI-NKP-PO-C-AM	Subscription, Nutanix Enterprise AI (NAI) Pro and Nutanix Kubernetes Platform (NKP) Pro Software License & L3 Mission Critical Software Support Service for 1 vCPU or 1 physical CPU Core (Authorized Service Provider provides L1, L2 support)
NT-AI-NKP-PO-C-FP	Subscription, Nutanix Enterprise AI (NAI) Pro and Nutanix Kubernetes Platform (NKP) Pro Software License & Federal Production Software Support Service for 1 vCPU or 1 physical CPU Core
NT-AI-NKP-PO-C-FM	Subscription, Nutanix Enterprise AI (NAI) Pro and Nutanix Kubernetes Platform (NKP) Pro Software License & Federal Mission Critical Software Support Service for 1 vCPU or 1 physical CPU Core
NAI NKP ULTIMATE	
NT-AI-NKP-UT-C-PR	Subscription, Nutanix Enterprise AI (NAI) Pro and Nutanix Kubernetes Platform (NKP) Ultimate Software License & Production Software Support Service for 1 vCPU or 1 physical CPU Core
NT-AI-NKP-UT-C-MC	Subscription, Nutanix Enterprise AI (NAI) Pro and Nutanix Kubernetes Platform (NKP) Ultimate Software License & Mission Critical Software Support Service for 1 vCPU or 1 physical CPU Core
NT-AI-NKP-UT-C-AP	Subscription, Nutanix Enterprise AI (NAI) Pro and Nutanix Kubernetes Platform (NKP) Ultimate Software License & L3 Production Software Support Service for 1 vCPU or 1 physical CPU Core (Authorized Service Provider provides L1, L2 support)

Table 21.11 Nutanix Enterprise AI (NAI)

NT-AI-NKP-UT-C-AM	Subscription, Nutanix Enterprise AI (NAI) Pro and Nutanix Kubernetes Platform (NKP) Ultimate Software License & L3 Mission Critical Software Support Service for 1 vCPU or 1 physical CPU Core (Authorized Service Provider provides L1, L2 support)
NT-AI-NKP-UT-C-FP	Subscription, Nutanix Enterprise AI (NAI) Pro and Nutanix Kubernetes Platform (NKP) Ultimate Software License & Federal Production Software Support Service for 1 vCPU or 1 physical CPU Core
NT-AI-NKP-UT-C-FM	Subscription, Nutanix Enterprise AI (NAI) Pro and Nutanix Kubernetes Platform (NKP) Ultimate Software License & Federal Mission Critical Software Support Service for 1 vCPU or 1 physical CPU Core

Nutanix software limited orderability

(1) End User Computing Hyperspace (EUCH):

Epic software is suite of software that is primarily used in the Healthcare industry. The Epic software can be deployed on Nutanix HCI. Solution & details can be found here (<https://portal.nutanix.com/page/documents/solutions/details?targetId=BP-2055-Epic-on-Nutanix:BP-2055-Epic-on-Nutanix>)

NTX-SW-LO is an ATO that has specific SKUs for Epic customers using Hyperspace or Hyperdrive. Hyperspace EUC SKU's begin with (NT-EUC-H-) and there are a total of 18 SKUs.

Refer to the link in the notes section for the process details

These SKUs can only be bought by customers who satisfy the following 2 conditions:

- End-user is Epic software customer (Epic headquarters is in Verona, WI)
- End-user must include the client presentation of Epic Hyperspace or Hyperdrive (component of the Epic suite of software). SKUs are for this component.



NOTE:

- KB article on process for EUC SKUs: <https://compute.kb.cisco.com/article/process-flow-when-ordering-hyperspace-euc-skus.html>
- Please note that the Federal Support program is reserved for US Federal accounts. US Federal accounts must select Federal Support Tier for the order to be fulfilled. If a non-Federal account selects a Federal Support program, Nutanix may not fulfill the order. Additionally, Nutanix's Mixed Support Level Guidelines(<https://www.nutanix.com/support-services/product-support/support-policies-and-faqs?show=accordion-4>) requires all software assets within a cluster to have the same support level, else software support will default to the lower option.
- Sellers in the Federal space need to ensure they have the Federal Support SKU's on the quote and order. All orders without the Federal Support SKU's will be rejected by Nutanix. Refer this Knowledge base article for more info: <https://compute.kb.cisco.com/article/nutanix-support-for-federal-customers.html>
- Authorized Partners of Nutanix can offer Level 1 & Level 2 support for Nutanix Software. for the complete list visit <https://compute.kb.cisco.com/article/rules-for-ordering-nutanix-partner-support-skus.html>

Table 22 End User Computing Hyperspace (EUCH)

Product ID (PID)	PID Description
STR - STARTER	
NT-EUC-H-STR-PR	Subscription, End User Computing (EUC) Starter Software License for Epic Hyperspace & Production Software Support Service for 1 User
NT-EUC-H-STR-MC	Subscription, End User Computing (EUC) Starter Software License for Epic Hyperspace & Mission Critical Software Support Service for 1 User
NT-EUC-H-STR-AP	Subscription, End User Computing (EUC) Starter Software License for Epic Hyperspace & L3 Production Software Support Service for 1 User (Authorized Support Partners provides L1, L2 support)

Table 22 End User Computing Hyperspace (EUCH)

NT-EUC-H-STR-AM	Subscription, End User Computing (EUC) Starter Software License for Epic Hyperspace & L3 Mission Critical Software Support Service for 1 User (Authorized Support Partners provides L1, L2 support)
NT-EUC-H-STR-FP	Subscription, End User Computing (EUC) Starter Software License for Epic Hyperspace & Federal Production Software Support Service for 1 User
NT-EUC-H-STR-FM	Subscription, End User Computing (EUC) Starter Software License for Epic Hyperspace & Federal Mission Critical Software Support Service for 1 User
PRO- PROFESSIONAL	
NT-EUC-H-PRO-PR	Subscription, End User Computing (EUC) Professional Software License for Epic Hyperspace & Production Software Support Service for 1 User
NT-EUC-H-PRO-MC	Subscription, End User Computing (EUC) Professional Software License for Epic Hyperspace & Mission Critical Software Support Service for 1 User
NT-EUC-H-PRO-AP	Subscription, End User Computing (EUC) Professional Software License for Epic Hyperspace & L3 Production Software Support Service for 1 User (Authorized Support Partners provides L1, L2 support)
NT-EUC-H-PRO-AM	Subscription, End User Computing (EUC) Professional Software License for Epic Hyperspace & L3 Mission Critical Software Support Service for 1 User (Authorized Support Partners provides L1, L2 support)
NT-EUC-H-PRO-FP	Subscription, End User Computing (EUC) Professional Software License for Epic Hyperspace & Federal Production Software Support Service for 1 User
NT-EUC-H-PRO-FM	Subscription, End User Computing (EUC) Professional Software License for Epic Hyperspace & Federal Mission Critical Software Support Service for 1 User
ULT - ULTIMATE	
NT-EUC-H-ULT-PR	Subscription, End User Computing (EUC) Ultimate Software License for Epic Hyperspace & Production Software Support Service for 1 User
NT-EUC-H-ULT-MC	Subscription, End User Computing (EUC) Ultimate Software License for Epic Hyperspace & Mission Critical Software Support Service for 1 User
NT-EUC-H-ULT-AP	Subscription, End User Computing (EUC) Ultimate Software License for Epic Hyperspace & L3 Production Software Support Service for 1 User (Authorized Support Partners provides L1, L2 support)
NT-EUC-H-ULT-AM	Subscription, End User Computing (EUC) Ultimate Software License for Epic Hyperspace & L3 Mission Critical Software Support Service for 1 User (Authorized Support Partners provides L1, L2 support)
NT-EUC-H-ULT-FP	Subscription, End User Computing (EUC) Ultimate Software License for Epic Hyperspace & Federal Production Software Support Service for 1 User
NT-EUC-H-ULT-FM	Subscription, End User Computing (EUC) Ultimate Software License for Epic Hyperspace & Federal Mission Critical Software Support Service for 1 User

Professional Services PIDs and Description

(1) NCI Design Workshop:

The Nutanix Cloud Infrastructure (NCI) Design Workshop offers IT teams in-depth and practical guidance to create a comprehensive design for on-premises NCI clusters. It covers various aspects such as scalability, functionality, integration, and operational needs. This workshop is beneficial during the Design stage of a Hybrid Multicloud journey, especially for complex solutions that involve third-party applications and automation.



NOTE:

- For more information on NCI Design workshop, please visit - <https://www.nutanix.com/content/dam/nutanix/resources/service-descriptions/sd-nci-design-workshop.pdf>
- For more information on Cisco version of Nutanix Professional services, please visit - <https://www.nutanix.com/content/dam/nutanix/resources/service-descriptions/professional-services-service-descriptions-cisco.pdf>

Table 23.0 NCI Design Workshop

Nutanix Software Product/Edition	Cisco Product PID	Cisco PID Description PS Offer Name - PS Offer Edition - PS Offer Option - Base/Variable	Nutanix PS Edition	Nutanix PS Option
NCI Starter	NT-W-DS-STR	NCI Design Workshop - Starter - Workshop Only	Starter	Workshop Only
NCI Starter	NT-W-DS-STR-SD	NCI Design Workshop - Starter - Standard Doc	Starter	Standard Documentation
NCI Pro	NT-W-DS-PRO	NCI Design Workshop - Pro - Workshop Only	Pro	Workshop Only
NCI Pro	NT-W-DS-PRO-SD	NCI Design Workshop - Pro - Enhanced Doc	Pro	Enhanced Documentation
NCI Ultimate	NT-W-DS-ULT-SD	NCI Design Workshop - Ultimate - Standard Doc	Ultimate	Standard Documentation

Table 25.0, Nutanix Software NCI, NCI-D, NCP (NCI-PRO), NCP (NCI-ULT), 1 YEAR SUBSCRIPTION with professional services PID Mapping

Table 25.1, Nutanix Software NCI, NCI-D, NCP (NCI-PRO), NCP (NCI-ULT), 3 YEAR SUBSCRIPTION with professional services PID Mapping

(2) NCI Cluster Deployment or Expansion:

The Nutanix Cloud Infrastructure (NCI) Cluster Deployment or Expansion accelerates the deployment of hybrid cloud infrastructure to support any application and workload. Highly skilled consultants can deploy on-premises NCI clusters or dedicated Nutanix Unified Storage (NUS) clusters. The clusters can be deployed to various supported hardware platforms, regardless of whether it's Nutanix, our OEM partners, or other platform providers. This offer is ideal for the Deploy stage of the Hybrid Multicloud journey.



NOTE:

- For more information on NCI Cluster deployment and expansion workshop, please visit - <https://www.nutanix.com/content/dam/nutanix/resources/service-descriptions/sd-nci-cluster-deployment-or-expansion.pdf>
- For more information on Cisco version of Nutanix Professional services, please visit - <https://www.nutanix.com/content/dam/nutanix/resources/service-descriptions/professional-services-service-descriptions-cisco.pdf>

Table 23.1 NCI Cluster Deployment or Expansion

Nutanix Software Product/Edition	Cisco Product PID	Cisco PID Description PS Offer Name - PS Offer Edition - PS Offer Option - Base/Variable	Nutanix PS Edition	Nutanix PS Option
NCI Starter	NT-S-DP-STR-AVB	NCI Cluster Deployment or Expansion - Starter - AHV - Base	Starter	AHV Nodes
NCI Starter	NT-S-DP-STR-AVV	NCI Cluster Deployment or Expansion - Starter - AHV - Var	Starter	AHV Nodes
NCI Starter	NT-S-DP-STR-EXB	NCI Cluster Deployment or Expansion - Starter - ESX - Base	Starter	ESX Nodes
NCI Starter	NT-S-DP-STR-EXV	NCI Cluster Deployment or Expansion - Starter - ESX - Var	Starter	ESX Nodes
NCI Pro	NT-S-DP-PRO-AV-SB	NCI Cluster Deployment or Expansion - Starter - AHV - Base	Starter	AHV Nodes
NCI Pro	NT-S-DP-PRO-AV-SV	NCI Cluster Deployment or Expansion - Starter - AHV - Var	Starter	AHV Nodes
NCI Pro	NT-S-DP-PRO-EX-SV	NCI Cluster Deployment or Expansion - Starter - ESX - Var	Starter	ESX Nodes
NCI Pro	NT-S-DP-PRO-EX-SB	NCI Cluster Deployment or Expansion - Starter - ESX - Base	Starter	ESX Nodes
NCI Pro	NT-S-DP-PRO-AV-PB	NCI Cluster Deployment or Expansion - Pro - AHV - Base	Pro	AHV Nodes
NCI Pro	NT-S-DP-PRO-AV-PV	NCI Cluster Deployment or Expansion - Pro - AHV - Var	Pro	AHV Nodes
NCI Pro	NT-S-DP-PRO-EX-PB	NCI Cluster Deployment or Expansion - Pro - ESX - Base	Pro	ESX Nodes
NCI Pro	NT-S-DP-PRO-EX-PV	NCI Cluster Deployment or Expansion - Pro - ESX - Var	Pro	ESX Nodes

Table 23.1 NCI Cluster Deployment or Expansion

NCI Ultimate	NT-S-DP-ULT-AV-SB	NCI Cluster Deployment or Expansion - Starter - AHV - Base	Starter	AHV Nodes
NCI Ultimate	NT-S-DP-ULT-AV-SV	NCI Cluster Deployment or Expansion - Starter - AHV - Var	Starter	AHV Nodes
NCI Ultimate	NT-S-DP-ULT-EX-SB	NCI Cluster Deployment or Expansion - Starter - ESX - Base	Starter	ESX Nodes
NCI Ultimate	NT-S-DP-ULT-EX-SV	NCI Cluster Deployment or Expansion - Starter - ESX - Var	Starter	ESX Nodes
NCI Ultimate	NT-S-DP-ULT-AV-PB	NCI Cluster Deployment or Expansion - Pro - AHV - Base	Pro	AHV Nodes
NCI Ultimate	NT-S-DP-ULT-AV-PV	NCI Cluster Deployment or Expansion - Pro - AHV - Var	Pro	AHV Nodes
NCI Ultimate	NT-S-DP-ULT-EX-PB	NCI Cluster Deployment or Expansion - Pro - ESX - Base	Pro	ESX Nodes
NCI Ultimate	NT-S-DP-ULT-EX-PV	NCI Cluster Deployment or Expansion - Pro - ESX - Var	Pro	ESX Nodes
NCI Ultimate	NT-S-DP-ULT-AV-UB	NCI Cluster Deployment or Expansion- Ultimate - AHV - Base	Ultimate	AHV Nodes
NCI Ultimate	NT-S-DP-ULT-AV-UV	NCI Cluster Deployment or Expansion- Ultimate - AHV - Var	Ultimate	AHV Nodes
NCI Ultimate	NT-S-DP-ULT-EX-UB	NCI Cluster Deployment or Expansion- Ultimate - ESX - Base	Ultimate	ESX Nodes
NCI Ultimate	NT-S-DP-ULT-EX-UV	NCI Cluster Deployment or Expansion- Ultimate - ESX - Var	Ultimate	ESX Nodes

[Table 25.0, Nutanix Software NCI, NCI-D, NCP \(NCI-PRO\), NCP \(NCI-ULT\), 1 YEAR SUBSCRIPTION with professional services PID Mapping](#)

[Table 25.1, Nutanix Software NCI, NCI-D, NCP \(NCI-PRO\), NCP \(NCI-ULT\), 3 YEAR SUBSCRIPTION with professional services PID Mapping](#)

(3) Virtual Machine Migration Workshop:

The Virtual Machine Migration Workshop offers IT teams in-depth and practical guidance to create a comprehensive virtual machine migration plan for migrating virtual machines to Nutanix Cloud Infrastructure (NCI). This offer is ideal for the Migrate state of a Hybrid Multicloud journey.



NOTE:

- For more information on Virtual Machine Migration Workshop, please visit - <https://www.nutanix.com/content/dam/nutanix/resources/service-descriptions/sd-virtual-machine-migration-workshop.pdf>
- For more information on Cisco version of Nutanix Professional services, please visit - <https://www.nutanix.com/content/dam/nutanix/resources/service-descriptions/professional-services-service-descriptions-cisco.pdf>

Table 23.2 Virtual Machine Migration Workshop

Nutanix Software Product/Edition	Cisco Product PID	Cisco PID Description PS Offer Name - PS Offer Edition - PS Offer Option - Base/Variable	Nutanix PS Edition	Nutanix PS Option
NCI Starter	NT-W-MG-STR-SD	Virtual Machine Migration Workshop - Standard Doc	None	Standard Documentation
NCI Pro	NT-W-MG-PRO-SD	Virtual Machine Migration Workshop - Standard Doc	None	Standard Documentation
NCI Ultimate	NT-W-MG-ULT-SD	Virtual Machine Migration Workshop - Standard Doc	None	Standard Documentation

[Table 25.0, Nutanix Software NCI, NCI-D, NCP \(NCI-PRO\), NCP \(NCI-ULT\), 1 YEAR SUBSCRIPTION with professional services PID Mapping](#)

[Table 25.1, Nutanix Software NCI, NCI-D, NCP \(NCI-PRO\), NCP \(NCI-ULT\), 3 YEAR SUBSCRIPTION with professional services PID Mapping](#)

(4) Virtual Machine Migration:

Virtual machine (VM) Migration offers IT teams strong domain expertise to migrate virtual machines to Nutanix Cloud Infrastructure (NCI) per the customer-provided migration plan. This offer is ideal for the Migrate stage of a Hybrid Multicloud journey



NOTE:

- For more information on Virtual Machine Migration, please visit - <https://www.nutanix.com/content/dam/nutanix/resources/service-descriptions/sd-virtual-machine-migration.pdf>
- For more information on Cisco version of Nutanix Professional services, please visit - <https://www.nutanix.com/content/dam/nutanix/resources/service-descriptions/professional-services-service-descriptions-cisco.pdf>

Table 23.3 Virtual Machine Migration

Nutanix Software Product/Edition	Cisco Product PID	Cisco PID Description PS Offer Name - PS Offer Edition - PS Offer Option - Base/Variable	Nutanix PS Edition	Nutanix PS Option
NCI Starter	NT-S-MG-VM-STR-AVB	Virtual Machine Migration - From AHV - Base	None	From AHV
NCI Starter	NT-S-MG-VM-STR-AVV	Virtual Machine Migration - From AHV - Var	None	From AHV
NCI Starter	NT-S-MG-VM-STR-EXB	Virtual Machine Migration - From ESX - Base	None	From ESX
NCI Starter	NT-S-MG-VM-STR-EXV	Virtual Machine Migration - From ESX - Var	None	From ESX
NCI Pro	NT-S-MG-VM-PRO-AVB	Virtual Machine Migration - From AHV - Base	None	From AHV
NCI Pro	NT-S-MG-VM-PRO-AVV	Virtual Machine Migration - From AHV - Var	None	From AHV
NCI Pro	NT-S-MG-VM-PRO-EXB	Virtual Machine Migration - From ESX - Base	None	From ESX
NCI Pro	NT-S-MG-VM-PRO-EXV	Virtual Machine Migration - From ESX - Var	None	From ESX
NCI Ultimate	NT-S-MG-VM-ULT-AVB	Virtual Machine Migration - From AHV - Base	None	From AHV
NCI Ultimate	NT-S-MG-VM-ULT-AVV	Virtual Machine Migration - From AHV - Var	None	From AHV
NCI Ultimate	NT-S-MG-VM-ULT-EXB	Virtual Machine Migration - From ESX - Base	None	From ESX
NCI Ultimate	NT-S-MG-VM-ULT-EXV	Virtual Machine Migration - From ESX - Var	None	From ESX

[Table 25.0, Nutanix Software NCI, NCI-D, NCP \(NCI-PRO\), NCP \(NCI-ULT\), 1 YEAR SUBSCRIPTION with professional services PID Mapping](#)

[Table 25.1, Nutanix Software NCI, NCI-D, NCP \(NCI-PRO\), NCP \(NCI-ULT\), 3 YEAR SUBSCRIPTION with professional services PID Mapping](#)

(5) NCM Self-Service Design Workshop:

The Nutanix Cloud Management (NCM) Self-Service Design Workshop offers automation teams in-depth and practical guidance to create a comprehensive design for application-centric infrastructure automation and lifecycle management (LCM) platforms to streamline and accelerate application development. This workshop is beneficial during the Design stage of a Hybrid Multicloud journey.



NOTE:

- For more information on Nutanix Cloud Management (NCM) Self-Service Design Workshop, please visit - <https://www.nutanix.com/content/dam/nutanix/resources/datasheets/professional-services-service-descriptions.pdf>
- For more information on Cisco version of Nutanix Professional services, please visit - <https://www.nutanix.com/content/dam/nutanix/resources/service-descriptions/professional-services-service-descriptions-cisco.pdf>

Table 23.4 NCM Self-Service Design Workshop

Nutanix Software Product/Edition	Cisco Product PID	Cisco PID Description PS Offer Name - PS Offer Edition - PS Offer Option - Base/Variable	Nutanix PS Edition	Nutanix PS Option
NCM Pro	NT-W-SSD-PRO-SD-S	NCM Self-Service Design Workshop - Starter - Standard Doc	Starter	Standard Documentation
NCM Pro	NT-W-SSD-PRO-SD-P	NCM Self-Service Design Workshop - Pro - Standard Doc	Pro	Standard Documentation
NCM Ultimate	NT-W-SSD-ULT-SD-S	NCM Self-Service Design Workshop - Starter - Standard Doc	Starter	Standard Documentation
NCM Ultimate	NT-W-SSD-ULT-SD-P	NCM Self-Service Design Workshop - Pro - Standard Doc	Pro	Standard Documentation

Table 26, Nutanix Software NCM STR 1 YEAR AND 3 YEAR & ABOVE SUBSCRIPTION with Professional Services PID Mapping

Table 27, Nutanix Software NCM PRO, NCM ULT, NCP (NCM-PRO), NCP (NCM-ULT) 1 YEAR AND 3 YEAR & ABOVE SUBSCRIPTION with Professional services

(6) NCM Intelligent Operations Design:

The Nutanix Cloud Management (NCM) Intelligent Operations Design Workshop offers IT teams in-depth and practical guidance to create a comprehensive design for Nutanix X-Play automation and playbooks to automate common tasks.



NOTE:

- For more information on NCM Intelligent Operations Design Workshop, please visit - <https://www.nutanix.com/content/dam/nutanix/resources/service-descriptions/sd-ncm-intelligent-operations-design.pdf>
- For more information on Cisco version of Nutanix Professional services, please visit - <https://www.nutanix.com/content/dam/nutanix/resources/service-descriptions/professional-services-service-descriptions-cisco.pdf>

Table 23.5 NCM Intelligent Operations Design Workshop

Nutanix Software Product/Edition	Cisco Product PID	Cisco PID Description PS Offer Name - PS Offer Edition - PS Offer Option - Base/Variable	Nutanix PS Edition	Nutanix PS Option
NCM Starter	NT-W-OD-STR-SD	NCM Intelligent Operations Design Workshop - Standard Doc	None	Standard Documentation
NCM Pro	NT-W-OD-PRO-SD	NCM Intelligent Operations Design Workshop - Standard Doc	None	Standard Documentation
NCM Ultimate	NT-W-OD-ULT-SD	NCM Intelligent Operations Design Workshop - Standard Doc	None	Standard Documentation

Table 26, Nutanix Software NCM STR 1 YEAR AND 3 YEAR & ABOVE SUBSCRIPTION with Professional Services PID Mapping

Table 27, Nutanix Software NCM PRO, NCM ULT, NCP (NCM-PRO), NCP (NCM-ULT) 1 YEAR AND 3 YEAR & ABOVE SUBSCRIPTION with Professional services

(7) NCM Intelligent Operations Deployment:

The Nutanix Cloud Management (NCM) Intelligent Operations Deployment accelerates the deployment of Nutanix X-Play automation and playbooks to automate common tasks with in-depth expertise from highly skilled consultants.



NOTE:

- For more information on NCM Intelligent Operations Deployment Workshop, please visit - <https://www.nutanix.com/content/dam/nutanix/resources/service-descriptions/sd-ncm-intelligent-operations-deployment.pdf>
- For more information on Cisco version of Nutanix Professional services, please visit - <https://www.nutanix.com/content/dam/nutanix/resources/service-descriptions/professional-services-service-descriptions-cisco.pdf>

Table 23.6 NCM Intelligent Operations Deployment

Nutanix Software Product/Edition	Cisco Product PID	Cisco PID Description PS Offer Name - PS Offer Edition - PS Offer Option - Base/Variable	Nutanix PS Edition	Nutanix PS Option
NCM Starter	NT-S-OP-STR	NCM Intelligent Operations Deployment	None	None
NCM Pro	NT-S-OP-PRO	NCM Intelligent Operations Deployment	None	None
NCM Ultimate	NT-S-OP-ULT	NCM Intelligent Operations Deployment	None	None

Table 26, Nutanix Software NCM STR 1 YEAR AND 3 YEAR & ABOVE SUBSCRIPTION with Professional Services PID Mapping

Table 27, Nutanix Software NCM PRO, NCM ULT, NCP (NCM-PRO), NCP (NCM-ULT) 1 YEAR AND 3 YEAR & ABOVE SUBSCRIPTION with Professional services

(8) FastTrack for NCM Self-Service:

FastTrack for Nutanix Cloud Manager (NCM) Self-Service accelerates the deployment and configuration of NCM Self-Service, which streamlines how teams manage, deploy, and scale applications across hybrid clouds with self-service, automation, and centralized role-based governance, with expertise from highly skilled automation consultants.



NOTE:

- For more information on Fast Track for NCM Self-Service, please visit - <https://www.nutanix.com/content/dam/nutanix/resources/service-descriptions/sd-ncm-intelligent-operations-deployment.pdf>
- For more information on Cisco version of Nutanix Professional services, please visit - <https://www.nutanix.com/content/dam/nutanix/resources/service-descriptions/professional-services-service-descriptions-cisco.pdf>

Table 23.7 FastTrack for NCM Self-Service

Nutanix Software Product/Edition	Cisco Product PID	Cisco PID Description PS Offer Name - PS Offer Edition - PS Offer Option - Base/Variable	Nutanix PS Edition	Nutanix PS Option
NCM Pro	NT-F-PRO-SS	FastTrack for NCM Self-Service	None	None
NCM Ultimate	NT-F-ULT-SS	FastTrack for NCM Self-Service	None	None

Table 26, Nutanix Software NCM STR 1 YEAR AND 3 YEAR & ABOVE SUBSCRIPTION with Professional Services PID Mapping

Table 27, Nutanix Software NCM PRO, NCM ULT, NCP (NCM-PRO), NCP (NCM-ULT) 1 YEAR AND 3 YEAR & ABOVE SUBSCRIPTION with Professional services

(9) FastTrack for NCM Cost Governance:

The FastTrack for Nutanix Cloud Management (NCM) Cost Governance accelerates the onboarding of deep visibility and rich analytics detailing cloud consumption patterns along with one-click cost optimization across cloud environments with expertise from highly skilled consultants. IT teams can choose to onboard on-premises Nutanix Cloud Infrastructure (NCI) clusters or a public cloud platform.



NOTE:

- For more information on Fast Track for NCM Cost Governance, please visit - <https://www.nutanix.com/content/dam/nutanix/resources/service-descriptions/sd-ncm-intelligent-operations-deployment.pdf>
- For more information on Cisco version of Nutanix Professional services, please visit - <https://www.nutanix.com/content/dam/nutanix/resources/service-descriptions/professional-services-service-descriptions-cisco.pdf>

Table 23.8 FastTrack for NCM Cost Governance

Nutanix Software Product/Edition	Cisco Product PID	Cisco PID Description PS Offer Name - PS Offer Edition - PS Offer Option - Base/Variable	Nutanix PS Edition	Nutanix PS Option
NCM Pro	NT-F-PRO-CG	FastTrack for NCM Cost Governance	None	None
NCM Ultimate	NT-F-ULT-CG	FastTrack for NCM Cost Governance	None	None

Table 26, Nutanix Software NCM STR 1 YEAR AND 3 YEAR & ABOVE SUBSCRIPTION with Professional Services PID Mapping

Table 27, Nutanix Software NCM PRO, NCM ULT, NCP (NCM-PRO), NCP (NCM-ULT) 1 YEAR AND 3 YEAR & ABOVE SUBSCRIPTION with Professional services

(10) NKP Design Workshop:

The NKP (Nutanix Kubernetes Platform) Design Workshop is a professional services offering that provides IT teams with in-depth and practical guidance to create a comprehensive design for on-premises Nutanix Cloud Infrastructure (NCI) clusters. This workshop covers various aspects such as scalability, functionality, integration, and operational needs. It is particularly beneficial during the Design stage of a Hybrid Multicloud journey, especially for complex solutions involving third-party applications and automation.



NOTE:

- For more information on NKP Design Workshop, please visit - <https://www.nutanix.com/viewer/content/dam/nutanix/en/resources/service-descriptions/sd-nkp-design-workshop.pdf>
- For more information on Cisco version of Nutanix Professional services, please visit - <https://www.nutanix.com/content/dam/nutanix/resources/service-descriptions/professional-services-service-descriptions-cisco.pdf>

Table 23.9 NKP Design Workshop

Nutanix Software Product/Edition	Cisco Product PID	Cisco PID Description		Nutanix PS Edition	Nutanix PS Option
		PS Offer Name - PS Offer Edition - PS Offer Option - Base/Variable			
NKP Starter	NT-W-KD-STR-SD	NKP Design Workshop - Essential - Std Doc (Qty=Provider)		None	Standard Documentation
NKP Pro	NT-W-KD-PRO-SD	NKP Design Workshop - Advantage - Std Doc (Qty=Provider)		None	Standard Documentation
NKP Ultimate	NT-W-KD-ULT-SD	NKP Design Workshop - Enterprise - Std Doc (Qty=Pair of Sites)		None	Standard Documentation

[Table 26, Nutanix Software NCM STR 1 YEAR AND 3 YEAR & ABOVE SUBSCRIPTION with Professional Services PID Mapping](#)

[Table 27, Nutanix Software NCM PRO, NCM ULT, NCP \(NCM-PRO\), NCP \(NCM-ULT\) 1 YEAR AND 3 YEAR & ABOVE SUBSCRIPTION with Professional services](#)

(11) NKP Deployment:

The Nutanix Kubernetes Platform (NKP) Deployment on Cisco Compute Hyperconverged infrastructure involves several key steps and components to automate and simplify Kubernetes cluster management.



NOTE:

- For more information on NCM Intelligent NKP Deployment, please visit - <https://www.nutanix.com/viewer/content/dam/nutanix/en/resources/service-descriptions/sd-nkp-deployment.pdf>
- For more information on Cisco version of Nutanix Professional services, please visit - <https://www.nutanix.com/content/dam/nutanix/resources/service-descriptions/professional-services-service-descriptions-cisco.pdf>

Table 23.10 NKP Deployment

Nutanix Software Product/Edition	Cisco Product PID	Cisco PID Description PS Offer Name - PS Offer Edition - PS Offer Option - Base/Variable	Nutanix PS Edition	Nutanix PS Option
NKP Starter	NT-S-KD-STR	NKP Deployment - Essential (Qty=Cluster)	None	None
NKP Pro	NT-S-KD-PRO	NKP Deployment - Advantage (Qty=Provider)	None	None
NKP Ultimate	NT-S-KD-ULT	NKP Deployment - Enterprise (Qty=Provider)	None	None

Table 26, Nutanix Software NCM STR 1 YEAR AND 3 YEAR & ABOVE SUBSCRIPTION with Professional Services PID Mapping

Table 27, Nutanix Software NCM PRO, NCM ULT, NCP (NCM-PRO), NCP (NCM-ULT) 1 YEAR AND 3 YEAR & ABOVE SUBSCRIPTION with Professional services

(12) Nutanix Services Flexible Credits:

Nutanix Flex Credits provide a credits program for purchasing Nutanix Professional Services. This program provides the flexibility to utilize your budget cycles to pre-buy credits for future use of Nutanix Professional Services and training via redemption of credits. Within the terms of validity of your Flex Credits, use the credits for the portfolio of Nutanix Professional Services including Consulting, Resident, Technical Account Manager, and Education.



NOTE:

- For more information on Nutanix Services Flexible Credits, please visit - <https://www.nutanix.com/content/dam/nutanix/resources/service-descriptions/sd-ncm-intelligent-operations-deployment.pdf>
- For more information on Cisco version of Nutanix Professional services, please visit - <https://www.nutanix.com/content/dam/nutanix/resources/service-descriptions/professional-services-service-descriptions-cisco.pdf>

Table 23.11 Nutanix Flexible Credits

Nutanix Software Product/Edition	Cisco Product PID	Cisco PID Description PS Offer Name - PS Offer Edition - PS Offer Option - Base/Variable	Nutanix PS Edition	Nutanix PS Option
All	NT-FLEX-CST-CR	Nutanix Services Flexible Credits (1 QTY = 100 Credits)	None	None

Table 26, Nutanix Software NCM STR 1 YEAR AND 3 YEAR & ABOVE SUBSCRIPTION with Professional Services PID Mapping

Table 27, Nutanix Software NCM PRO, NCM ULT, NCP (NCM-PRO), NCP (NCM-ULT) 1 YEAR AND 3 YEAR & ABOVE SUBSCRIPTION with Professional services

Nutanix Support:

Table 24 Nutanix Support

Product ID (PID)	PID Description
Nutanix Support	
SVS-NT-SUP	Entitlement ONLY for Nutanix Cloud Infrastructure SW

Software With Professional Services PID Mapping



NOTE: Recommended to select the matching/higher level of service options for the subscribed software. For example: If ULT (Ultimate) software is selected, recommended to choose the ULT services from the below columns. However, it is allowed to select the lower version of the services.

Table 25.0 Nutanix Software NCI, NCI-D, NCP (NCI-PRO), NCP (NCI-ULT), **1 YEAR SUBSCRIPTION** with professional services PID Mapping

Software PIDs	Mandatory Professional Services PIDs	
	NCI Design Workshop (select one service)	NCI Cluster Deployment or Expansion (select a Pair of service)
STR: NCI NT-NCI-STR-PR NT-NCI-STR-MC NT-NCI-STR-AP NT-NCI-STR-AM NT-NCI-STR-FP NT-NCI-STR-FM NCI-D NT-NCI-D-STR-PR NT-NCI-D-STR-MC NT-NCI-D-STR-AP NT-NCI-D-STR-AM NT-NCI-D-STR-FP NT-NCI-D-STR-FM	STR: NT-W-DS-STR NT-W-DS-STR-SD PRO: NT-W-DS-PRO NT-W-DS-PRO-SD ULT: NT-W-DS-ULT-SD	STR: NT-S-DP-STR-AVB and NT-S-DP-STR-AVV or NT-S-DP-STR-EXB and N T-S-DP-STR-EXV PRO: NT-S-DP-PRO-AV-SB and NT-S-DP-PRO-AV-SV or NT-S-DP-PRO-EX-SB and NT-S-DP-PRO-EX-SV or NT-S-DP-PRO-AV-PB and NT-S-DP-PRO-AV-PV or NT-S-DP-PRO-EX-PB and NT-S-DP-PRO-EX-PV ULT: NT-S-DP-ULT-AV-SB and NT-S-DP-ULT-AV-SV or NT-S-DP-ULT-EX-SB and NT-S-DP-ULT-EX-SV or NT-S-DP-ULT-AV-PB and NT-S-DP-ULT-AV-PV or NT-S-DP-ULT-EX-PB and NT-S-DP-ULT-EX-PV or NT-S-DP-ULT-AV-UB and NT-S-DP-ULT-AV-UV or NT-S-DP-ULT-EX-UB and NT-S-DP-ULT-EX-UV

Table 25.0 Nutanix Software NCI, NCI-D, NCP (NCI-PRO), NCP (NCI-ULT), 1 YEAR SUBSCRIPTION with professional services PID Mapping

<p>PRO: NCI NT-NCI-PRO-PR NT-NCI-PRO-MC NT-NCI-PRO-AP NT-NCI-PRO-AM NT-NCI-PRO-FP NT-NCI-PRO-FM</p> <p>NCI-D NT-NCI-D-PRO-PR NT-NCI-D-PRO-MC NT-NCI-D-PRO-AP NT-NCI-D-PRO-AM NT-NCI-D-PRO-FP NT-NCI-D-PRO-FM</p> <p>NCP (NCI-PRO) NT-NCP-NCI-PRO-PR NT-NCP-NCI-PRO-MC NT-NCP-NCI-PRO-AP NT-NCP-NCI-PRO-AM NT-NCP-NCI-PRO-FP NT-NCP-NCI-PRO-FM</p>		
--	--	--

Table 25.0 Nutanix Software NCI, NCI-D, NCP (NCI-PRO), NCP (NCI-ULT), 1 YEAR SUBSCRIPTION with professional services PID Mapping

<p>ULT:</p> <p>NCI</p> <p>NT-NCI-ULT-PR NT-NCI-ULT-MC NT-NCI-ULT-AP NT-NCI-ULT-AM NT-NCI-ULT-FP NT-NCI-ULT-FM</p> <p>NCI-D</p> <p>NT-NCI-D-ULT-PR NT-NCI-D-ULT-MC NT-NCI-D-ULT-AP NT-NCI-D-ULT-AM NT-NCI-D-ULT-FP NT-NCI-D-ULT-FM</p> <p>NCP (NCI-ULT)</p> <p>NT-NCP-NCI-ULT-PR NT-NCP-NCI-ULT-MC NT-NCP-NCI-ULT-AP NT-NCP-NCI-ULT-AM NT-NCP-NCI-ULT-FP NT-NCP-NCI-ULT-FM</p>		
--	--	--



NOTE: Recommended to select the matching/higher level of service options for the subscribed software. For example: If ULT (Ultimate) software is selected, recommended to choose the ULT services from the below columns. However, it is allowed to select the lower version of the services.

Table 25.1 Nutanix Software NCI, NCI-D, NCP (NCI-PRO), NCP (NCI-ULT), **3 YEAR SUBSCRIPTION** with professional services PID Mapping

Software PIDs	Mandatory Professional Services PIDs	
	NCI Design Workshop (select one service)	NCI Cluster Deployment or Expansion (select a Pair of service)
STR: NCI NT-NCI-STR-PR NT-NCI-STR-MC NT-NCI-STR-AP NT-NCI-STR-AM NT-NCI-STR-FP NT-NCI-STR-FM NCI-D NT-NCI-D-STR-PR NT-NCI-D-STR-MC NT-NCI-D-STR-AP NT-NCI-D-STR-AM NT-NCI-D-STR-FP NT-NCI-D-STR-FM	STR: NT-W-DS-STR NT-W-DS-STR-SD PRO: NT-W-DS-PRO NT-W-DS-PRO-SD ULT: NT-W-DS-ULT-SD	STR: NT-S-DP-STR-AVB and NT-S-DP-STR-AVV or NT-S-DP-STR-EXB and N T-S-DP-STR-EXV PRO: NT-S-DP-PRO-AV-SB and NT-S-DP-PRO-AV-SV or NT-S-DP-PRO-EX-SB and NT-S-DP-PRO-EX-SV or NT-S-DP-PRO-AV-PB and NT-S-DP-PRO-AV-PV or NT-S-DP-PRO-EX-PB and NT-S-DP-PRO-EX-PV ULT: NT-S-DP-ULT-AV-SB and NT-S-DP-ULT-AV-SV or NT-S-DP-ULT-EX-SB and NT-S-DP-ULT-EX-SV or NT-S-DP-ULT-AV-PB and NT-S-DP-ULT-AV-PV or NT-S-DP-ULT-EX-PB and NT-S-DP-ULT-EX-PV or NT-S-DP-ULT-AV-UB and NT-S-DP-ULT-AV-UV or NT-S-DP-ULT-EX-UB and NT-S-DP-ULT-EX-UV

Table 25.1 Nutanix Software NCI, NCI-D, NCP (NCI-PRO), NCP (NCI-ULT), 3 YEAR SUBSCRIPTION with professional services PID Mapping

<p>PRO:</p> <p>NCI</p> <p>NT-NCI-PRO-PR NT-NCI-PRO-MC NT-NCI-PRO-AP NT-NCI-PRO-AM NT-NCI-PRO-FP NT-NCI-PRO-FM</p> <p>NCI-D</p> <p>NT-NCI-D-PRO-PR NT-NCI-D-PRO-MC NT-NCI-D-PRO-AP NT-NCI-D-PRO-AM NT-NCI-D-PRO-FP NT-NCI-D-PRO-FM</p> <p>NCP (NCI-PRO)</p> <p>NT-NCP-NCI-PRO-PR NT-NCP-NCI-PRO-MC NT-NCP-NCI-PRO-AP NT-NCP-NCI-PRO-AM NT-NCP-NCI-PRO-FP NT-NCP-NCI-PRO-FM</p>		
--	--	--

Table 25.1 Nutanix Software NCI, NCI-D, NCP (NCI-PRO), NCP (NCI-ULT), 3 YEAR SUBSCRIPTION with professional services PID Mapping

<p>ULT:</p> <p>NCI</p> <p>NT-NCI-ULT-PR NT-NCI-ULT-MC NT-NCI-ULT-AP NT-NCI-ULT-AM NT-NCI-ULT-FP NT-NCI-ULT-FM</p> <p>NCI-D</p> <p>NT-NCI-D-ULT-PR NT-NCI-D-ULT-MC NT-NCI-D-ULT-AP NT-NCI-D-ULT-AM NT-NCI-D-ULT-FP NT-NCI-D-ULT-FM</p> <p>NCP (NCI-ULT)</p> <p>NT-NCP-NCI-ULT-PR NT-NCP-NCI-ULT-MC NT-NCP-NCI-ULT-AP NT-NCP-NCI-ULT-AM NT-NCP-NCI-ULT-FP NT-NCP-NCI-ULT-FM</p>		
--	--	--



NOTE: Recommended to select the matching/higher level of service options for the subscribed software. For example: If ULT (Ultimate) software is selected, recommended to choose the ULT services from the below columns. However, it is allowed to select the lower version of the services.

Table 26 Nutanix Software NCM STR [redacted] with Professional Services PID Mapping

Software PIDs	Recommended Professional Services PIDs	
	NCM Intelligent Operations Design (select one service)	NCM Intelligent Operations Deployment (select one service)
STR: NCM NT-NCM-STR-PR NT-NCM-STR-MC NT-NCM-STR-AP NT-NCM-STR-AM NT-NCM-STR-FP NT-NCM-STR-FM	STR: NT-W-OD-STR-SD PRO: NT-W-OD-PRO-SD ULT: NT-W-OD-ULT-SD	STR: NT-S-OP-STR PRO: NT-S-OP-PRO ULT: NT-S-OP-ULT



NOTE: Recommended to select the matching/higher level of service options for the subscribed software. For example: If ULT (Ultimate) software is selected, recommended to choose the ULT services from the below columns. However, it is allowed to select the lower version of the services.

Table 27 Nutanix Software NCM PRO, NCM ULT, NCP (NCM-PRO), NCP (NCM-ULT) with Professional services

Software PIDs	Mandatory Professional Services PIDs	
	NCM Intelligent Operations Design (select one service)	NCM Intelligent Operations Deployment (select one service)
PRO: NCM NT-NCM-PRO-PR NT-NCM-PRO-MC NT-NCM-PRO-AP NT-NCM-PRO-AM NT-NCM-PRO-FP NT-NCM-PRO-FM NCP (NCM-PRO) NT-NCP-NCM-PRO-PR NT-NCP-NCM-PRO-MC NT-NCP-NCM-PRO-AP NT-NCP-NCM-PRO-AM NT-NCP-NCM-PRO-FP NT-NCP-NCM-PRO-FM ULT: NCM NT-NCM-ULT-PR NT-NCM-ULT-MC NT-NCM-ULT-AP NT-NCM-ULT-AM NT-NCM-ULT-FP NT-NCM-ULT-FM NCP (NCM-ULT) NT-NCP-NCM-ULT-PR NT-NCP-NCM-ULT-MC NT-NCP-NCM-ULT-AP NT-NCP-NCM-ULT-AM NT-NCP-NCM-ULT-FP NT-NCP-NCM-ULT-FM	STR: NT-W-OD-STR-SD PRO: NT-W-OD-PRO-SD ULT: NT-W-OD-ULT-SD	STR: NT-S-OP-STR PRO: NT-S-OP-PRO ULT: NT-S-OP-ULT

SUPPLIMENT MATERIAL

System Board

A top view of the Server system board is shown in [Figure 5](#).

Figure 5 Cisco Compute Hyperconverged with Nutanix XE130c M8 Edge Server System Board

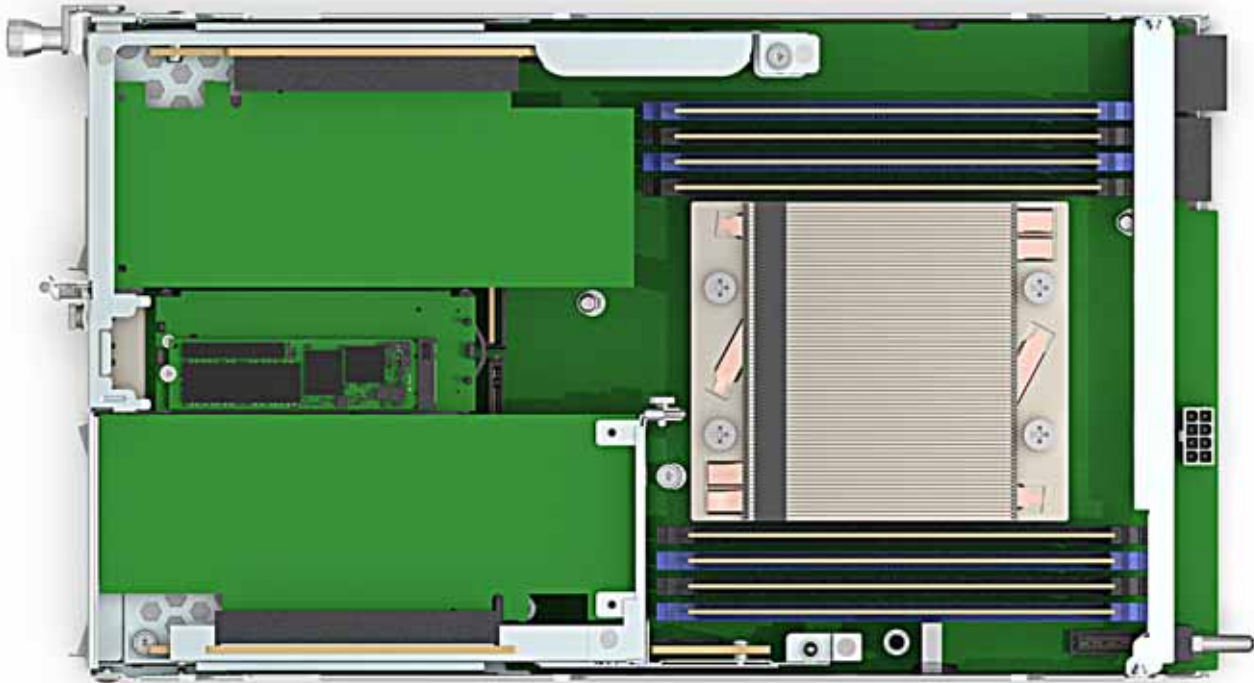

TECHNICAL SPECIFICATIONS

Dimensions and Weight

Table 28 Server Dimensions and Weight

Parameter	Value
Height	1.61 in. (41 mm)
Width	8.19 in. (208 mm)
Depth	13.86 in. (352 mm)
Weight	<ul style="list-style-type: none"> ■ Minimally configured node weight: 6.61 lbs. (3.0 kg) ■ Fully configured server weight: 8.82 lbs. (4.0 kg)

Environmental Specifications

Table 29 Environmental Specifications

Parameter	Value
Operating temperature	23° to 113° F (-5° to 45° C)
Non-operating temperature	-40° to 185° F (-40° to 85° C)
Operating humidity	5% to 85% noncondensing
Non-operating humidity	5% to 93% noncondensing
Operating altitude	0 to 10,000 ft (0 to 3000m); maximum ambient temperature decreases by 1° C per 300m
Non-operating altitude	40,000 ft (12,000m)

System Requirements

Table 30 System Requirements

Parameter	Value
Cisco Unified Edge Chassis	Cisco UCS XE9305 chassis
Cisco Intersight	Intersight Managed Mode (minimum Essentials license per server)

Power Specifications

For configuration-specific power specifications, use the Cisco UCS Power Calculator at:

<http://ucspowercalc.cisco.com>



NOTE: The Cisco Compute Hyperconverged XE130c Server Node has a power cap of 1300 Watts for all combinations of components (CPUs, DIMMs, drives, and so on). Also, the ambient temperature must be less than 35 °C (95 °F).



Americas Headquarters
Cisco Systems, Inc.
San Jose, CA

Asia Pacific Headquarters
Cisco Systems (USA) Pte. Ltd.
Singapore

Europe Headquarters
Cisco Systems International BV Amsterdam,
The Netherlands

Cisco has more than 200 offices worldwide. Addresses, phone numbers, and fax numbers are listed on the Cisco Website at www.cisco.com/go/offices.

Cisco and the Cisco Logo are trademarks of Cisco Systems, Inc. and/or its affiliates in the U.S. and other countries. A listing of Cisco's trademarks can be found at www.cisco.com/go/trademarks. Third party trademarks mentioned are the property of their respective owners. The use of the word partner does not imply a partnership relationship between Cisco and any other company. (1005R)