



Cisco Compute Hyperconverged with vSAN

HCIVS220C M8 All-NVMe vSAN ReadyNode

A printed version of this document is only a copy and not necessarily the latest version. Refer to the following link for the latest released version:
<https://www.cisco.com/c/en/us/products/hyperconverged-infrastructure/compute-hyperconverged/datasheet-listing.html>

CONTENTS

OVERVIEW	3
DETAILED VIEWS	4
Detailed Chassis Front View	4
Detailed Chassis Rear Views	5
Three Half-Height Risers	6
Two Full-Height Risers	7
BASE SERVER STANDARD CAPABILITIES and FEATURES	8
CONFIGURING the SERVER	10
STEP 1 SELECT SERVER SKU	11
STEP 2 AI INTENT (OPTIONAL)	12
STEP 3 SELECT MANAGEMENT MODE (REQUIRED)	13
STEP 4 SELECT RISER CARDS (REQUIRED)	14
STEP 5 SELECT CPU(s) (REQUIRED)	15
STEP 6 SELECT MEMORY (REQUIRED)	18
Memory configurations and mixing rules	20
STEP 7 SELECT DRIVE CONTROLLERS	21
STEP 8 SELECT DRIVES (REQUIRED)	22
STEP 9 SELECT OPTION CARD(s) (OPTIONAL)	24
ORDER OPTIONAL PCIe OPTION CARD ACCESSORIES	28
STEP 10 ORDER GPU CARDS (OPTIONAL)	29
STEP 11 ORDER POWER SUPPLY (REQUIRED)	30
STEP 12 SELECT INPUT POWER CORD(s) (REQUIRED)	31
STEP 13 ORDER TOOL-LESS RAIL KIT (REQUIRED) AND REVERSIBLE CABLE MANAGEMENT ARM (OPTIONAL)	35
STEP 14 ORDER SECURITY DEVICES (REQUIRED)	36
SUPPLEMENTAL MATERIAL	37
Serial Port Details	37
KVM Cable	38
TECHNICAL SPECIFICATIONS	39
Dimensions and Weight	39
Dimensions and Weight	40
Power Specifications	41
Compliance Requirements	45

CONTENTS

OVERVIEW

VMware vSAN Express Storage Architecture (ESA) is a software-defined storage solution that runs natively as part of ESXi hypervisor. It aggregates local storage from multiple hosts to create a shared storage pool for virtual machines that can then be accessed by all hosts in the vSAN cluster.

Cisco Compute Hyperconverged with vSAN solutions are purpose-built platforms that unify compute, storage, and networking into a single, software-defined infrastructure. Cisco and VMware by Broadcom have partnered to deliver a robust, scalable, and high-performance hyperconverged infrastructure (HCI) solution for modern workloads.

VMware vSAN ReadyNodes is pre-configured, tested, and jointly certified by Broadcom and Cisco to deliver enterprise-grade storage performance and reliability for IT customers. When deployed on Cisco UCS® servers qualified as vSAN Ready Nodes customers can confidently build a robust hyperconverged infrastructure stack that maximizes hardware utilization, simplifies operations, and scales linearly with business growth.

The Cisco Compute Hyperconverged HCI V5220C M8 All-NVMe vSAN ReadyNode harnesses the power of the latest Intel® Xeon® 6 Scalable Processors. Refer to [BASE SERVER STANDARD CAPABILITIES and FEATURES, page 8](#).

See [Figure 1 on page 3](#) for front and rear views of the Cisco Compute Hyperconverged HCI V5220C M8 All-NVMe vSAN ReadyNode.

Figure 1 Cisco Compute Hyperconverged HCI V5220C M8 All-NVMe vSAN ReadyNode

Front View



Rear View (three half-height riser card version)



Rear View (two full-height riser card version - shown with riser blanks installed)



DETAILED VIEWS

Detailed Chassis Front View

Figure 2 shows the detailed front view of the server

Figure 2 Detailed Chassis Front View

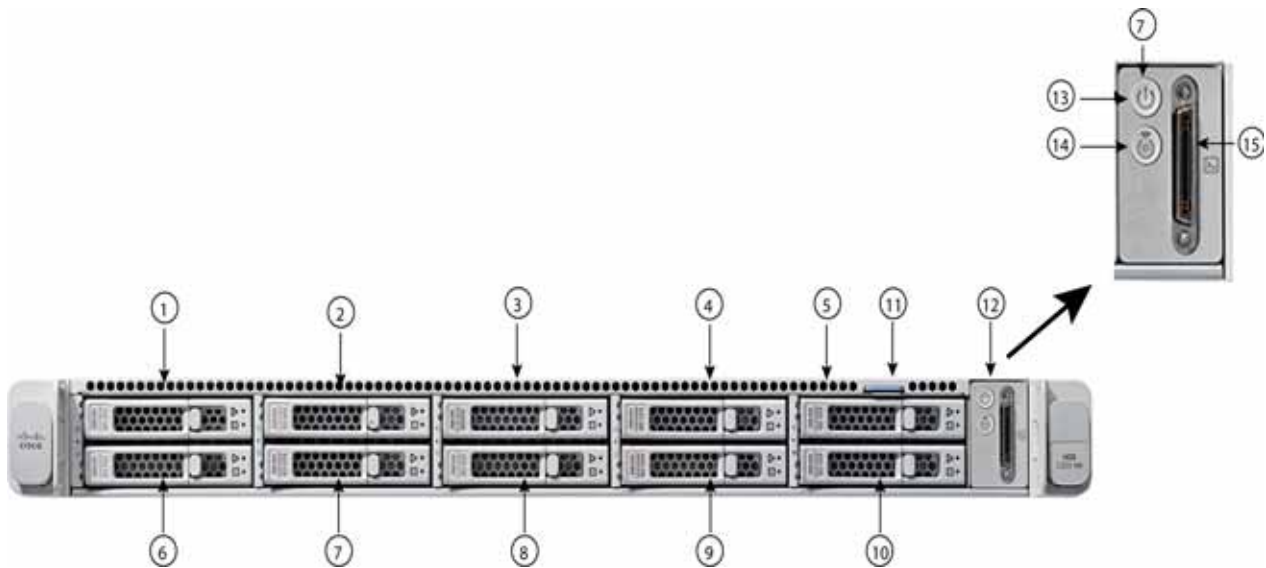

1	Drive bays 1 - 10 support direct attach NVMe	4	Power button/power status LED
2	Asset Tag	5	Unit Identification button/LED
3	Control panel	6	KVM connector (used with KVM cable that provides two USB 2.0, one VGA, and one serial connector)

Detailed Chassis Rear Views

Figure 3 shows the details of the rear panel for the server with three rear half-height PCIe risers.

Figure 4 shows the details of the rear panel for the server with two rear full-height PCIe risers.

Three Half-Height Risers



NOTE: Only 2-CPU servers support all three half-height risers.

Figure 3 Chassis Rear View (three half-height, 3/4 length PCIe risers)

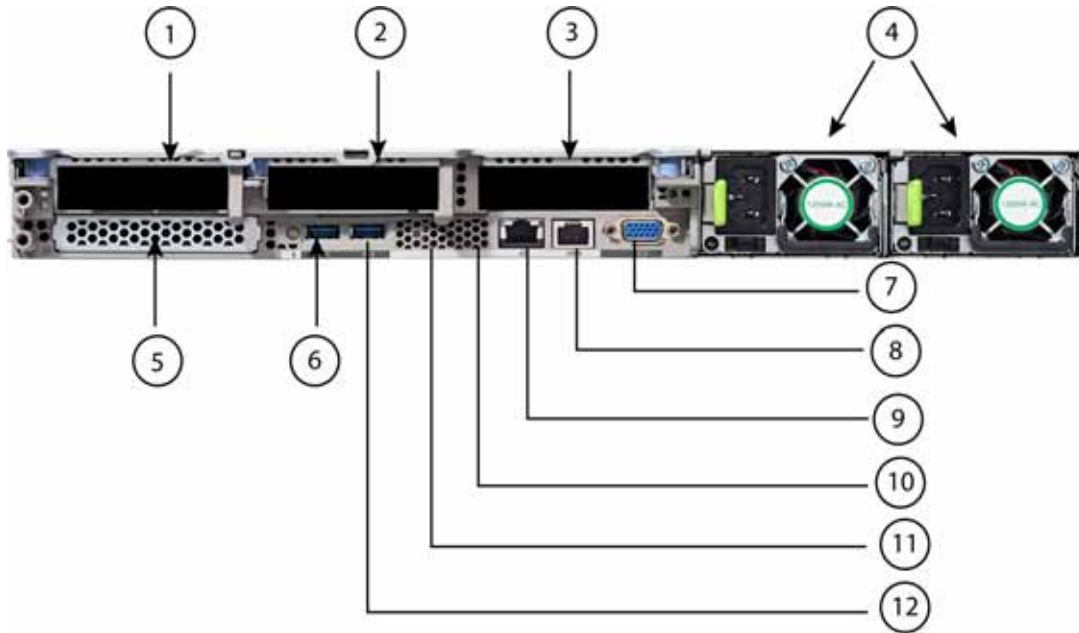

1	Riser 1A PCIe Gen5 (CPU1 control) <ul style="list-style-type: none"> ■ Supports one PCIe slot (slot 1) ■ Slot 1 is half-height, 3/4 length, x16, NCSI, Single Wide GPU 	6	System ID pushbutton/LED
2	Riser 2A PCIe Gen5 x16 (CPU1 control) <ul style="list-style-type: none"> ■ Supports one PCIe slot (slot 2) ■ Slot 2 is half-height, 3/4 length, x16, Single Wide GPU 	7	VGA display port (DB15 connector)
3	Riser 3A PCIe Gen5 x16 (CPU2 control) <ul style="list-style-type: none"> ■ Supports one PCIe slot (slot 3) ■ Slot 3 is half-height, 3/4 length, x16, NCSI, Single Wide GPU 	8	COM port (RJ45 connector)
4	Power supplies (two, redundant as 1+1)	9	1GBE dedicated Ethernet management port
5	Modular LAN on motherboard (mLOM)/OCP 3.0 slot or hot-swappable M.2 module.	10	USB 3.0 ports (two)

Two Full-Height Risers



NOTE: 1-CPU servers support only full-height riser 1 while 2-CPU servers support both full-height risers.

Figure 4 Chassis Rear View (two full-height, 3/4-length PCIe risers)

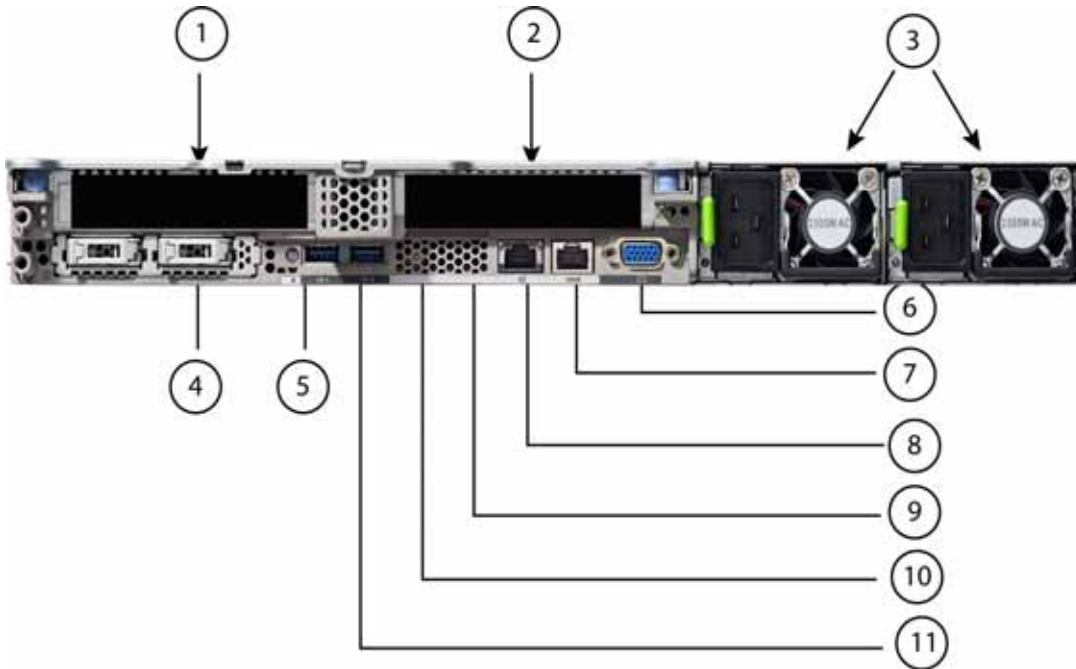

1	Riser 1B PCIe Gen5 (CPU1 control) <ul style="list-style-type: none"> ■ Supports one PCIe slot (slot 1) ■ Slot 1 is full-height, 3/4 length, x16,NCSI, Single Wide GPU 	6	VGA display port (DB15 connector)
2	Riser 3B PCIe Gen5 x16 (CPU2 control) <ul style="list-style-type: none"> ■ Supports one PCIe slot (slot 3) ■ Slot 3 is Full-height, 3/4 length, x16, NCSI, Single Wide GPU 	7	COM port (RJ45 connector)
3	Power supplies (two, redundant as 1+1)	8	1GBE dedicated Ethernet management port
4	Modular LAN on motherboard (mLOM)/OCP 3.0 slot or hot-swappable M.2 module (drive bays 241 and 242).	9	USB 3.0 ports (two)
5	System ID pushbutton/LED	-	-

BASE SERVER STANDARD CAPABILITIES and FEATURES

Table 1 lists the capabilities and features of the base server. Details about how to configure the server for a particular feature or capability (for example, number of processors, drives, or amount of memory) are provided in *CONFIGURING the SERVER, page 10*.

Table 1 Capabilities and Features

Capability/Feature	Description
Chassis	One rack unit (1RU) chassis
CPU	<ul style="list-style-type: none"> ■ One or two Intel® Xeon® 6 Scalable Processors ■ Each CPU has 8 channels with up to 2 DIMMs per channel, for up to 16 DIMMs per CPU ■ UPI Links: Up to 3 at 24GT/s
Memory	<ul style="list-style-type: none"> ■ 32 total DDR5-6400 MT/s DIMM slots with Intel® Xeon® 6 Scalable Processors (16 per CPU) ■ Up to 16x MRDIMM 8000MT/s
Video	<p>The Cisco Integrated Management Controller (CIMC) provides video using the Matrox G200e video/graphics controller:</p> <ul style="list-style-type: none"> ■ Integrated 2D graphics core with hardware acceleration ■ Embedded DDR memory interface supports up to 512 MB of addressable memory (8 MB is allocated by default to video memory) ■ Supports display resolutions up to 1920 x 1200 16bpp @ 60Hz ■ High-speed integrated 24-bit RAMDAC ■ Single lane PCI-Express host interface running at Gen 1 speed
Power subsystem	<p>Up to two of the following hot-swappable power supplies:</p> <ul style="list-style-type: none"> ■ 1050W (DC) ■ 1200W (AC) ■ 1600 W (AC) ■ 2300 W (AC) <p>One power supply is mandatory; one more can be added for 1 + 1 redundancy.</p>
Front Panel	A front panel controller provides status indications and control buttons
ACPI	This server supports the advanced configuration and power interface (ACPI) 6.2 standard.
Fans	Eight hot-swappable fans for front-to-rear cooling
Expansion slots	<ul style="list-style-type: none"> ■ Half-height riser slots (select up to three) <ul style="list-style-type: none"> • Riser 1A PCIe Gen5 x16 HH • Riser 2A PCIe Gen5 x16 HH • Riser 3A PCIe Gen5 x16 HH (CPU2 Control) ■ Full-height riser slots (select up to two) <ul style="list-style-type: none"> • Riser 1B PCIe Gen5 x16 FH • Riser 3B PCIe Gen5 x16 FH (CPU2 Control)

Table 1 Capabilities and Features *(continued)*

Capability/Feature	Description						
Interfaces	<ul style="list-style-type: none"> ■ Rear panel <ul style="list-style-type: none"> • One 1Gbase-T RJ-45 management port • One RS-232 serial port (RJ45 connector) • One DB15 VGA connector • Two USB 3.0 port connectors • One flexible modular LAN on motherboard (mLOM/OCP 3.0) slot that can accommodate various interface cards ■ Front panel <ul style="list-style-type: none"> • One KVM console connector (supplies two USB 2.0 connectors, one VGA DB15 video connector, and one serial port (RS232) RJ45 connector) 						
Integrated management processor	<ul style="list-style-type: none"> ■ Baseboard Management Controller (BMC) running Cisco Integrated Management Controller (CIMC) firmware. ■ Depending on your CIMC settings, the CIMC can be accessed through the 1GE dedicated management port. Cisco virtual interface card (VIC). ■ CIMC manages certain components within the server 						
Internal storage devices	<p>Drive storage:</p> <ul style="list-style-type: none"> ■ Up to 10 NVMe solid state drives (SSDs).  <hr/> <p>Note: Drives are installed into front-panel drive bays, which provide hot-swappable access for NVMe drives.</p> <p>Other storage:</p> <ul style="list-style-type: none"> ■ A Boot Optimized RAID Controller supports <ul style="list-style-type: none"> • Up to two internal SATA M.2 SSDs, or • Up to two rear-accessible hot-swappable SATA M.2 SSDs ■ 8GB FlexMMC utility storage for staging of firmware and other user data. 8GB FlexMMC storage is built into the motherboard on M8. 						
Modular LAN on Motherboard (mLOM)/ Open Compute Project (OCP) 3.0 slot	<p>The dedicated mLOM/Open Compute Project (OCP) 3.0 slot on the motherboard can flexibly accommodate the following cards:</p> <ul style="list-style-type: none"> ■ Cisco Virtual Interface Cards ■ Open Compute Project (OCP) 3.0 network interface card 						
Fabric Interconnect	<ul style="list-style-type: none"> ■ Compatible with the Cisco UCS 6454, 64108, 6536, 6664 and UCSX-S9108-100G fabric interconnects. ■ In addition to direct-connect of rack-server to the Fabric Interconnect, the rack-server can also connect via the “Nexus 93180YC-FX3 FEX” for having up to 160 servers behind a pair of Fabric Interconnect. 						
CIMC	Cisco Integrated Management Controller 4.3 (6) or later						
Intersight	Intersight provides server management capabilities						
Firmware standards	<table border="0"> <tr> <td>UEFI Spec</td> <td>2.9</td> </tr> <tr> <td>ACPI</td> <td>6.5</td> </tr> <tr> <td>SMBIOS Ver</td> <td>3.7</td> </tr> </table>	UEFI Spec	2.9	ACPI	6.5	SMBIOS Ver	3.7
UEFI Spec	2.9						
ACPI	6.5						
SMBIOS Ver	3.7						

CONFIGURING the SERVER

Follow these steps to configure the Cisco Compute Hyperconverged HCIVS220C M8 All-NVMe vSAN ReadyNode:

- *STEP 1 SELECT SERVER SKU, page 11*
- *STEP 2 AI INTENT (OPTIONAL), page 12*
- *STEP 3 SELECT MANAGEMENT MODE (REQUIRED), page 13*
- *STEP 3 SELECT MANAGEMENT MODE (REQUIRED), page 13*
- *STEP 4 SELECT RISER CARDS (REQUIRED), page 14*
- *STEP 5 SELECT CPU(s) (REQUIRED), page 15*
- *STEP 6 SELECT MEMORY (REQUIRED), page 18*
- *STEP 7 SELECT DRIVE CONTROLLERS, page 21*
- *STEP 8 SELECT DRIVES (REQUIRED), page 22*
- *STEP 9 SELECT OPTION CARD(s) (OPTIONAL), page 24*
- *STEP 10 ORDER GPU CARDS (OPTIONAL), page 29*
- *STEP 11 ORDER POWER SUPPLY (REQUIRED), page 30*
- *STEP 12 SELECT INPUT POWER CORD(s) (REQUIRED), page 31*
- *STEP 13 ORDER TOOL-LESS RAIL KIT (REQUIRED) AND REVERSIBLE CABLE MANAGEMENT ARM (OPTIONAL), page 35*
- *STEP 14 ORDER SECURITY DEVICES (REQUIRED), page 36*

STEP 1 SELECT SERVER SKU

Top level ordering product ID (PID) is shown in [Table 2](#).

Table 2 Top Level Major Line Bundle ordering PIDs (MLB)

Product ID (PID)	Description
HCI-M8-VSAN-MLB	Cisco Compute Hyperconverged M8 with vSAN MLB

Select one product ID (PID) as shown in [Table 3](#).



CAUTION: This product may not be purchased outside of the approved bundles (must be ordered under the MLB)

Table 3 PID of the Base Server

Product ID (PID)	Description
HCIVS220C-M8SN	Cisco Compute Hyperconverged HCI 220cM8 NVMe vSAN Node

The Cisco Compute Hyperconverged HCIVS220C M8 All-NVMe vSAN ReadyNode:

- Includes a 10 NVMe drive backplane.
- Does not include power supply, CPU, memory, NVMe drives, SD cards, riser 1, riser 2, riser 3, tool-less rail kit, or PCIe cards.
- Use the steps on the following pages to configure the server with the components that you want to include.

STEP 2 AI INTENT (OPTIONAL)

Select AI Intent

- The available AI Intent options are listed in [Table 4](#).

Table 4 AI Intent

Product ID (PID)	Description
COMPUTE-AI	Compute Artificial Intelligence Use Case
COMPUTE-OTHER	Compute Other Use Case

STEP 3 SELECT MANAGEMENT MODE (REQUIRED)

The available management modes are listed in [Table 5](#).

Table 5 Management Modes

Product ID (PID)	Description
IMM-MANAGED	Deployment mode for UCS FI connected Servers in IMM mode
UMM-MANAGED	Deployment mode for UCS FI connected Servers in UCSM mode
ISM-MANAGED	Deployment mode for C Series Servers in Standalone mode



NOTE: Cisco UCS M8 servers are the last generation to support UCS Manager (UCSM). Any customers choosing to use UCSM with M8 servers should proactively plan to transition to IMM by 2027.

STEP 4 SELECT RISER CARDS (REQUIRED)

The riser PIDs are listed in [Table 6](#).



CAUTION: Full-height risers cannot be mixed with half-height risers

Table 6 PIDs of the Risers and Riser Blanks

Product ID (PID)	Description
Riser 1 Option	
UCSC-RIS1A-220M8	UCS C220 M8 Riser 1A PCIe Gen5 x16 HH <ul style="list-style-type: none"> ■ Half-height riser 1 (controlled by CPU 1) ■ One x16 PCIe Gen5 riser, standard PCIe, supports Cisco VIC, half-height, 3/4 length
UCSC-RIS1B-220M8	UCS C220 M8 Riser 1B PCIe Gen5 x16 FH <ul style="list-style-type: none"> ■ Half-height riser 1 (controlled by CPU 1) ■ One x16 PCIe Gen5 riser, standard PCIe, supports Cisco VIC, half-height, 3/4 length
Riser 2 Option	
UCSC-RIS2A-220M8	UCS C220 M8 Riser 2A PCIe Gen5 x16 HH <ul style="list-style-type: none"> ■ Half-height riser 2 (controlled by CPU 1) ■ One x16 PCIe Gen5 riser, standard PCIe, half-height, 3/4 length
Riser 3 Option	
UCSC-RIS3A-220M8	UCS C220 M8 Riser 3A PCIe Gen5 x16 HH (CPU2) <ul style="list-style-type: none"> ■ Half-height riser 3 (controlled by CPU 2) ■ One x16 PCIe Gen5 riser, standard PCIe, supports Cisco VIC, half-height, 3/4 length
UCSC-RIS3B-220M8	UCS C220 M8 Riser 3B PCIe Gen5 x16 FH (CPU2) <ul style="list-style-type: none"> ■ Full-height riser 3 (controlled by CPU 2) ■ One x16 PCIe Gen5 riser, standard PCIe, supports Cisco VIC, full-height, 3/4 length
Accessories/spare included along with selected risers: <ul style="list-style-type: none"> ■ UCSC-FBRSF-220M8 is auto included if only one full height riser is selected ■ UCSC-FBRS2-C220M7 and UCSC-FBRS-C220-D are auto included if only Riser 1A is selected ■ UCSC-FBRS-C220-D is auto included if only Riser 1A and 2A are selected 	

Approved Configurations

(1) Half-height riser 1A, 2A, and 3A only. riser 1A and 2A are controlled from CPU1 and Riser 3 is controlled from CPU2.

Full-height risers 1B and 3B only. Riser 1B is controlled from CPU1 and riser 3B is controlled from CPU2.

STEP 5 SELECT CPU(s) (REQUIRED)

The standard CPU features are:

- Up to 86 cores
- Cache size of up to 336 MB
- Power: Up to 350 Watts
- UPI Links: Up to 4 at 24GT/s

Select CPUs from [Table 7](#)



CAUTION:

- Normal operating temperature is limited to 35° C [95° F], and is lowered to 28° C [82.4° F], with a fan fault. When rear drives are installed, the normal operating temperature is lowered to 30° C [86° F], and 26° C [78.8° F], respectively with a fan fault.
- With multiple GPU>75W installed, normal operating temperature is 30° C [86° F], lowered to 25° C [77° F], with a fan fault.
- When a GPU>75W is installed, CPUs with TDP greater than 330W are not supported

Table 7 Available Intel® Xeon® 6 Scalable CPUs

Product ID	Segment/ Workload	Maximum Socket	Cores	Clock Freq	Power	Cache Size	Highest DDR5 DIMM Clock
(PID)		(S)	(C)	(GHz)	(W)	(MB)	(MT/s)
UCS-CPU-I6787P	Performance	2S	86	2.00	350	336	6400
UCS-CPU-I6781P ¹	Single Socket	1S	80	2.00	350	336	6400
UCS-CPU-I6767P	Performance	2S	64	2.40	350	336	6400
UCS-CPU-I6761P ¹	Single Socket	1S	64	2.50	350	336	6400
UCS-CPU-I6760P	Mainline	2S	64	2.20	330	320	6400
UCS-CPU-I6747P	Performance	2S	48	2.70	330	288	6400
UCS-CPU-I6741P ¹	Single Socket	1S	48	2.50	300	288	6400
UCS-CPU-I6740P	Mainline	2S	48	2.10	270	288	6400
UCS-CPU-I6736P	Performance	2S	36	2.00	205	144	6400
UCS-CPU-I6745P	Performance	2S	32	3.10	300	336	6400
UCS-CPU-I6737P	Performance	2S	32	2.90	270	144	6400
UCS-CPU-I6731P ¹	Single Socket	1S	32	2.50	245	144	6400
UCS-CPU-I6730P	Performance	2S	32	2.50	250	288	6400

Table 7 Available Intel® Xeon® 6 Scalable CPUs

Product ID	Segment/ Workload	Maximum Socket	Cores	Clock Freq	Power	Cache Size	Highest DDR5 DIMM Clock
(PID)		(S)	(C)	(GHz)	(W)	(MB)	(MT/s)
UCS-CPU-I6530P	Mainline	2S	32	2.30	225	144	6400
UCS-CPU-I6728P	Socket scalable	2S	24	2.70	210	144	6400
UCS-CPU-I6527P	Performance	2S	24	3.00	255	144	6400
UCS-CPU-I6521P ¹	Single Socket	1S	24	2.60	225	144	6400
UCS-CPU-I6520P	Mainline	2S	24	2.40	210	144	6400
UCS-CPU-I6511P ¹	Single Socket	1S	16	2.50	150	72	6400
UCS-CPU-I6724P	Performance	2S	16	3.60	210	72	6400
UCS-CPU-I6517P	Performance	2S	16	3.20	190	72	6400
UCS-CPU-I6515P	Mainline	2S	16	2.40	150	72	6400
UCS-CPU-I6505P	Mainline	2S	12	2.20	150	48	6400
UCS-CPU-I6714P	Performance	2S	8	4.00	165	48	6400
UCS-CPU-I6507P	Performance	2S	8	3.50	150	48	6400
Accessories/spare included with CPU configuration: ■ UCSC-HSLP-C220M8 NOTE: if you are adding a second CPU later, you may need to order accessories spares with it.							

Notes:

1. Single Socket only CPUs

Table 8 CPU PID Decoder

Identifier#1	Identifier#2	Identifier#3	Identifier#4	Identifier#5	Identifier#6	Identifier#7
Cisco Product Family	CPU supplier	CPU Generation	SKU Tier	CPU SKU (2 digits)	Core Architecture	Option/Spare CPU
UCS	I: Intel	6: 6th Generation	5: GNR-SP Mid Tier 7: GNR-SP High Tier	Examples: 20, 34, 48 See detailed SKUs stack from supplier 11, 21, 31, 41, 61, 81: single-socket	P: P-Core	Blank: Option =: Spare

Supported Configurations

- 1-CPU Configuration:
 - Choose one CPU from [Table 7](#)
- 2-CPU Configuration:
 - Choose two identical CPUs from [Table 7](#)

STEP 6 SELECT MEMORY (REQUIRED)

The [Table 9](#) below describes the main memory DIMM features supported on the server.

Table 9 Server Main Memory Features

Memory server technologies	Description	
	DIMM	MRDIMM ¹
Intel® Xeon® CPU generation	Intel® Xeon® 6 CPUs	
DDR5 memory clock speed	Up to 6400 MT/s 1DPC; Up to 5200 MT/s 2DPC	Up to 8000 MT/s 1DPC
Operational voltage	1.1 Volts	
DRAM fab density	16Gb, 24Gb and 32Gb	16Gb
Memory type	RDIMM (Registered DDR5 DIMM)	MRDIMM (Multiplexed Rank DDR5 DIMM)
Memory DRAM DIMM/MRDIMM organization	Eight memory DIMM channels per CPU; up to 2 DIMMs Per Channel	Eight MRDIMM channels per CPU; 1 DIMM Per Channel
Maximum number of DRAM DIMM/MRDIMM per server	32 (2-Socket)	16 (2-Socket)
DRAM DIMM/MRDIMM Densities and Ranks	16GB 1Rx8, 32GB 1Rx4, 32GB 2Rx8, 48GB 1Rx4, 64GB 2Rx4, 96GB 2Rx4, 128GB 2Rx4, 256GB 4Rx4	32GB 2Rx8, 64GB 2Rx4
Maximum system memory capacity	8TB (32x256GB)	1TB (16x64GB)

Notes:

1. Intel® Xeon® SKUs 6747P supports MRDIMM, Per Intel® Xeon® 6 documentation

Figure 5 Cisco UCS 220 M8 Memory Organization

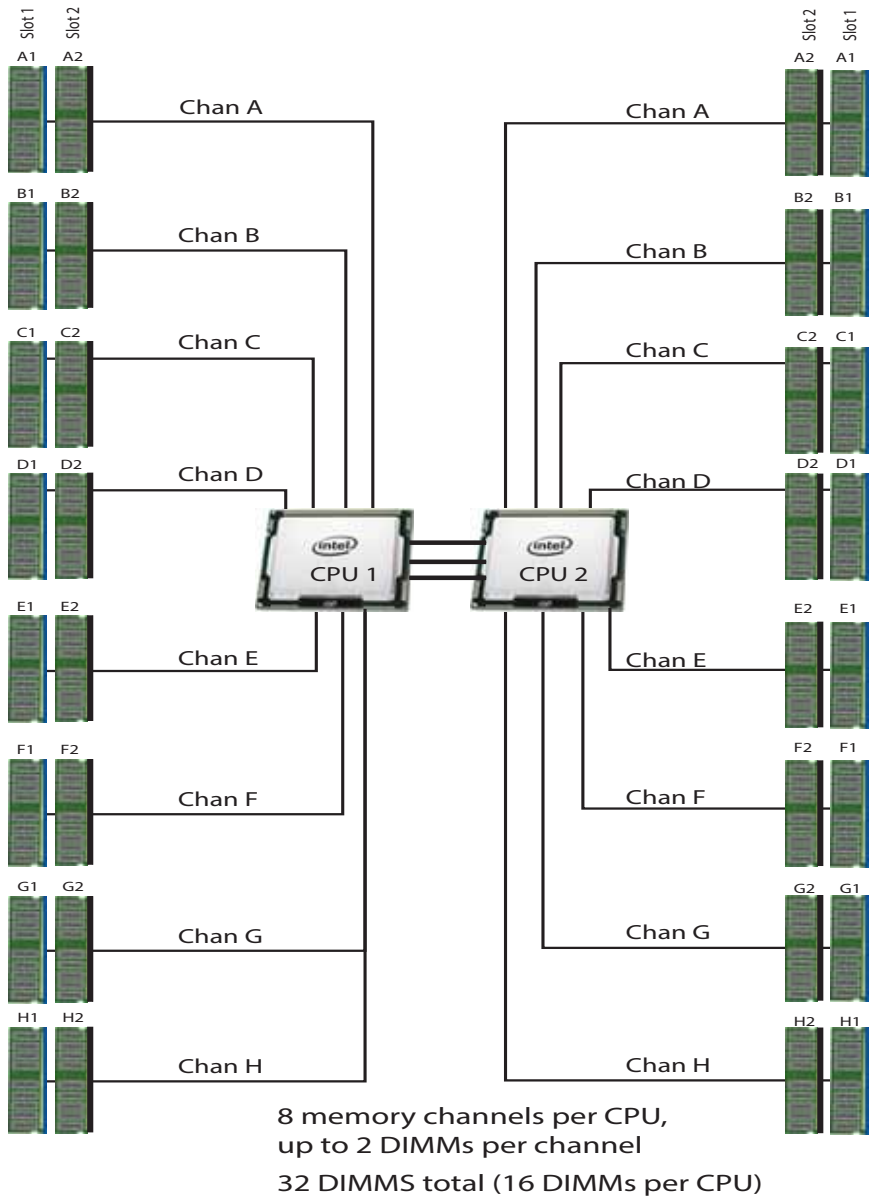

Select DIMMs

The available memory DIMMs option are listed in [Table 10](#).



CAUTION: On 220 M8, when 256GB DIMMs are configured in the server, ambient temperature is limited to a maximum of 30°C.

Table 10 Memory Options for M8 servers with Intel® Xeon® 6th Gen. CPUs

Product ID (PID)	PID Description	Ranks/DIMM
DDR5-6400 MT/s Cisco Memory PIDs list		
UCS-MRX16G1RE5	16GB RDIMM 1Rx8 1.1Volts (16Gb)	1
UCS-MRX32G1RE5	32GB RDIMM 1Rx4 1.1Volts (16Gb)	1
UCS-MRX32G2RE5	32GB RDIMM 2Rx8 1.1Volts (16Gb)	2
UCS-MRX48G1RF5	48GB RDIMM 1Rx4 1.1Volts (24Gb)	1
UCS-MRX64G2RE5	64GB RDIMM 2Rx4 1.1Volts (16Gb)	2
UCS-MRX96G2RF5	96GB RDIMM 2Rx4 1.1Volts (24Gb)	2
UCS-MR128G2RG5	128GB RDIMM 2Rx4 1.1Volts (32Gb)	2
UCS-MR256G4RG5	256GB RDIMM 4Rx4 1.1Volts (32Gb)	4
DDR5 MRDIMM-8800 MT/s Cisco Memory PIDs list		
UCS-MCX32G2RE11 ¹	32GB DDR5 MRDIMM 8800 2Rx8 (16Gb)	2
UCS-MCX64G2RE11 ¹	64GB DDR5 MRDIMM 8800 2Rx4 (16Gb)	2
Accessories/spare included with Memory configuration:		
<ul style="list-style-type: none"> ■ UCS-DDR5-BLK¹ is auto included for the unselected DIMMs slots 		

Notes:

1. Any empty DIMM slot must be populated with a DIMM blank to maintain proper cooling airflow.

Memory configurations and mixing rules

- **Golden Rule:** Memory on every CPU socket shall be configured identically.
- For full details on supported memory configurations, count rules, population rules and mixing rules see the [Intel M8 Memory guide](#)

STEP 7 SELECT DRIVE CONTROLLERS



NOTE: There is no raid controller support for this Server

STEP 8 SELECT DRIVES (REQUIRED)

The standard drive features are:

- NVMe Drives
- Hot-pluggable
- Drives come mounted in sleds

Select Drives

The available drives listed [Table 11](#)



CAUTION: Cisco uses solid state drives (SSDs) from a number of vendors. All solid state drives (SSDs) are subject to physical write limits and have varying maximum usage limitation specifications set by the manufacturer. Cisco will not replace any solid state drives (SSDs) that have exceeded any maximum usage specifications set by Cisco or the manufacturer, as determined solely by Cisco.

Table 11 Available Drives

Product ID (PID)	PID Description	Drive Type	Capacity	Memory Tier Support
Capacity Drive				
UCS-NVMEG4-M1600D	1.6TB 2.5in U.3 15mm P7450 Hg Perf Hg End NVMe (3X)	NVMe	1.6 TB	Yes
UCS-NVMEG4-M7680D	7.6TB 2.5in U.3 15mm P7450 Hg Perf Med End NVMe	NVMe	7.6 TB	Yes
UCS-NVMEG4-M1536D	15.3TB 2.5in U.3 15mm P7450 Hg Perf Med End NVMe	NVMe	15.3 TB	Yes
UCS-NVMEG4-M6400D	6.4TB 2.5in U.3 15mm Micron P7450 Hg Perf Hg End NVMe (3X)	NVMe	6.4 TB	Yes
UCS-NVB1T9M2V	1.9TB 2.5in U.3 15mm Micron 7500 Hg Perf Med End 1X NVMe	NVMe	1.9 TB	No
UCS-NVB3T2M2P	3.2TB 2.5in U.3 15mm Micron 7500 Hg Perf Hg End 3X NVMe	NVMe	3.2 TB	Yes
UCS-NVB3T8M2V	3.8TB 2.5in U.3 15mm Micron 7500 Hg Perf Med End 1X NVMe	NVMe	3.8 TB	No
UCS-NVB7T6M2V	7.6TB 2.5in U.3 15mm Micron 7500 Hg Perf Med End 1X NVMe	NVMe	7.6 TB	No
Boot Drive				
UCS-M2-480G-D	480GB M.2 SATA SSD	SATA	480GB	
UCS-M2-960G-D	960GB M.2 SATA Micron G2 SSD	SATA	960GB	
UCS-M2480OA1V	480GB M.2 Boot Solidigm S4520 SATA 1X SSD	SATA	480GB	
M.2 Raid controller (Internal)				
UCS-M2-HWRAID2	Cisco Boot optimized M.2 Raid controller for SATA drives			

Approved Configurations

- Combined two to ten capacity tier and memory tier drives
- Two boot drives with M.2 Raid controller

**NOTE:**

- Dual M.2 SATA SSD with the HW RAID controller is the only supported boot configuration for this solution.
 - It is recommended that M.2 SATA SSDs be used as boot-only devices.
 - Two identical M.2 SATA SSDs for the boot optimized RAID controller
 - You cannot mix M.2 SATA SSD capacities.
 - The SATA M.2 drives can boot in UEFI mode only. Legacy boot mode is not supported.
 - CIMC is supported for configuring of volumes and monitoring of the controller and installed SATA M.2 drives
-

STEP 9 SELECT OPTION CARD(S) (OPTIONAL)

For up-to-date server compatibility, please check the Hardware and Software compatibility list (HCL) at <https://ucshcltool.cloudapps.cisco.com/public/>.

The standard PCIe card offerings are:

- Modular LAN on Motherboard (mLOM)
- Open Compute Project (OCP) 3.0
- Virtual Interface Cards (VICs)
- Network Interface Cards (NICs)
- Host Bus Adapters (HBAs)

Select Option Cards



NOTE:

- Refer to [Cisco UCS C220 M8 Installation Guide](#) for the more information

The available option cards are listed in [Table 12](#)

Table 12 Available PCIe Option Cards

Product ID (PID)	PID Description	Location	Card Size ¹
Modular LAN on Motherboard (mLOM)²			
UCSC-M-V5Q50GV2-D	Cisco VIC 15427 4x 10/25/50G mLOM C-Series w/Secure Boot	mLOM	HHHL, SS
UCSC-M-V5D200GV2D	Cisco VIC 15237 2x 40/100/200G mLOM C-Series w/Secure Boot	mLOM	HHHL, SS
Open Compute Project (OCP)³			
UCSC-O-N6CD25GFO	NVIDIA OEM MCX631432AC-ADAB CX6Lx 2x25G SFP28 x8 OCP NIC	OCP	SFF
UCSC-O-N6CD100GFO	NVIDIA OEM MCX623436AC-CDAB CX6Dx 2x100G QSFP56 x16 OCP NIC	OCP	SFF
Virtual Interface Cards (VICs)²			
UCSC-P-V5Q50G-D	Cisco VIC 15425 4x 10/25/50G PCIe C-Series w/Secure Boot	Riser 1 or 3	HHHL, SS
UCSC-P-V5D200G-D	Cisco VIC 15235 2x 40/100/200G PCIe C-Series w/Secure Boot	Riser 1 or 3	HHHL, SS
Network Interface Cards (NICs)			
10GbE NICs			
UCSC-P-ID10GC-D	Cisco-Intel X710T2LG 2x10GBE RJ45 PCIe NIC	Riser 1, 2, or 3	HHHL, SS
UCSC-P-IQ10GC-D	Cisco-Intel X710T4LG 4x10GBE RJ45 PCIe NIC	Riser 1, 2, or 3	HHHL, SS
25GbE NICs			
UCSC-P-I8D25GF-D	Cisco-Intel E810XXVDA2 2x25/10GBE SFP28 PCIe NIC	Riser 1, 2, or 3	HHHL, SS

Table 12 Available PCIe Option Cards (*continued*)

Product ID (PID)	PID Description	Location	Card Size ¹
UCSC-P-N6D25GFO	NVIDIA OEM MCX631102AS-ADAT CX6Lx 2x25GbE SFP28 x8 PCIe NIC	Riser 1, 2, or 3	HHHL, SS
UCSC-P-N7Q25GF	CX713104AS-ADAT: 4x25GbE SFP56 Gen4x16, PCIe NIC	Riser 1, 2, or 3	HHHL, SS
UCSC-P-I8Q25GF-D	Cisco-Intel E810XXVDA4L 4x25/10 GbE SFP28 PCIe NIC	Riser 1, 2, or 3	FHHL, SS
100GbE NICs			
UCSC-P-M6CD100GFO	NVIDIA OEM MCX623106AC-CDAT, 2x100 GbE QSFP56 PCIe Crypto	Riser 1, 2, or 3	HHHL, SS
UCSC-P-M6DD100GFO	NVIDIA OEM MCX623106AS-CDAT, 2x100 GbE QSFP56 PCIe No Crypto	Riser 1, 2, or 3	HHHL, SS
UCSC-P-I8D100GF-D	Cisco-Intel E810CQDA2 2x100 GbE QSFP28 PCIe NIC	Riser 1, 2, or 3	HHHL, SS
200GbE NICs			
UCSC-P-N7D200GF	MCX755106AS-HEAT: CX-7 2x200GbE QSFP112 PCIe Gen5x16, VPI NIC	Riser 1, 2, or 3	HHHL, SS
Host Bus Adapters (HBAs)			
UCSC-P-Q6D32GF-D	Cisco-QLogic QLE2772 2x32GFC Gen 6 Enhanced PCIe HBA	Riser 1, 2, or 3	HHHL, SS
UCSC-P-B7D32GF-D	Cisco-Emulex LPe35002-M2-2x32GFC Gen 7 PCIe HBA	Riser 1, 2, or 3	HHHL, SS
UCSC-PCIEBD16GF-D	Emulex LPe31002 dual port 16G FC HBA	Riser 1, 2, or 3	HHHL, SS
UCSC-P-Q7D64GF	Cisco-QLogic QLE2872, 2x64GFC Gen 7 PCIe HBA	Riser 1, 2, or 3	HHHL, SS
Accessories/spare included with PCI Card.			
<ul style="list-style-type: none"> ■ UCSC-OCP3-KIT-D is included along with the selection Open Compute Project (OCP) card 			

Notes:

1. HHHL = half-height, half-length; FHHL = full-height, half-length; SS = single-slot; DS = double-slot. SFF = small form factor.
2. 50G speed on the 4-port and 200G speed on the 2-port are only supported on standalone servers with supported cables. Please refer to the [VIC 15000 series datasheet](#) for supported switches and cables.
3. For installation in the mLOM slot, you can order either an mLOM VIC, or the OCP NIC - but not both. If ordering the OCP NIC, the OCP Mechanical Kit (UCSC-OCP3-KIT) must also be installed in order to mount OCP NIC in the mLOM slot.
4. This Virtual Interface Cards incorporate VIC Secure Boot technology.

Approved Configurations

(1) 1-CPU Systems

- You can select up to two of the PCIe option cards listed in [Table 12](#) to be installed in Riser 1 and Riser 2. Riser 1 and Riser 2 is controlled by CPU 1. Risers 3 cannot installed in a 1-CPU system.

(2) 2-CPU Systems

- You can select up to two of the PCIe option cards listed in [Table 12](#) for a two-riser system and up to three of the PCIe option cards for a three-riser system. Risers 1 and 2 are controlled by CPU and riser 3 is controlled by CPU 2.

Caveats

- For 1-CPU systems:
 - Half Height Riser 1 and Riser 2 is supported. Full Height Riser 1 is supported
 - Only a single plug-in PCIe VIC card is supported and must be installed in Riser 1. However, in addition to the one PCIe VIC card, you can also choose to install an mLOM/OCP 3.0 card in the mLOM slot at the rear of the chassis.
- For 2-CPU systems:
 - All risers (Risers 1, 2, and 3) are supported
 - Two plug-in PCIe VIC cards can be installed in 2-CPU systems. VICs can be placed in Riser 1 or 3 only in half height riser combination. For full height riser, you can use either Riser 1 or 3 for the VICs. In addition, you can order an mLOM/OCP 3.0 card, which is installed in the mLOM/OCP 3.0 slot at the rear of the chassis and thus have three VIC cards in operation at the same time. See [Table 12 on page 24](#) for the selection of plug-in and mLOM VIC cards.
- To help ensure that your operating system is compatible with the card you have selected, or to see additional cards that have been qualified to work with the server, but are not sold on the Cisco pricelist, check the Hardware Compatibility List at this URL:
http://www.cisco.com/en/US/products/ps10477/prod_technical_reference_list.html

- For installation in the mLOM slot, you can order either an mLOM VIC, or the OCP NIC - but not both. If ordering the OCP NIC, the OCP Mechanical Kit (UCSC-OCP3-KIT) must also be installed in order to mount OCP NIC in the mLOM slot.

**NOTE:**

- UCSM managed servers are discoverable only if a PCIe VIC is installed or a VIC is installed in the MLOM slot.
 - Select Cisco UCS Virtual Interface Cards incorporate VIC Secure Boot technology to ensure the integrity of the VIC hardware and firmware upon server boot. VIC Secure Boot is independent of server-level secure boot from Cisco, but both technologies contribute to the Cisco trust model ensuring customers' equipment is genuine and running validated firmware.
 - To help ensure that your operating system is compatible with the card you have selected, or to see additional cards that have been qualified to work with the UCS C220 M8 server, but are not sold on the Cisco price list, check the [Hardware Compatibility List](#) link.
-

ORDER OPTIONAL PCIe OPTION CARD ACCESSORIES

- At the time of first launch, the 3rd Party Ethernet adapters were tested for interoperability with an initial selection of Optical Modules and Cables. Please check the Product Briefs for this initial list of interoperable optics and cables at <https://www.cisco.com/c/en/us/products/servers-unified-computing/third-party-adapters-listing.html>.
- For list of supported optics and cables for VIC 15428 and VIC 15238, refer to the VIC 15000 series data sheet at <https://www.cisco.com/c/en/us/products/collateral/interfaces-modules/unified-computing-system-adapters/ucs-vic-15000-series-ds.html>
- Cisco Transceiver Module Group (TMG) conducts tests with Cisco optics and cables and publishes the results in the TMG Compatibility Matrix. The latest compatibility with optical modules and DACs can be found at <https://tmgmatrix.cisco.com/>
- Refer to the these links for additional connectivity options.

Intel:
Product Guide
Speed White Paper

STEP 10 ORDER GPU CARDS (OPTIONAL)

Select GPU Options

The available GPU PCIe options are listed in [Table 13](#)

Table 13 Available PCIe GPU Cards¹

Product ID (PID)	PID Description	Card Size	Maximum cards Per node	Riser Compatibility
UCSC-GPU-L4	NVIDIA L4:70W, 24GB, 1-slot HHHL GPU	HHHL, single-wide	3	All Risers

Notes:

1. Refer to [installation guide](#) for the more details.



NOTE:

- All GPU cards must be procured from Cisco as there is a unique SBIOS ID required by CIMC and UCSM
- GPUs cannot be mixed.
- Refer to [Cisco UCS C220 M8 Installation Guide](#) for the more information

STEP 11 ORDER POWER SUPPLY (REQUIRED)

Power supplies share a common electrical and physical design that allows for hot-plug and tool-less installation into M8 C-series servers. Each power supply is certified for high-efficiency operation and offers multiple power output options. This allows users to “right-size” based on server configuration, which improves power efficiency, lowers overall energy costs and avoids stranded capacity in the datacenter.

Use the power calculator at the following link to determine the needed power based on the options chosen (CPUs, drives, memory, and so on):

<http://ucspowercalc.cisco.com>



WARNING:

- Starting 1st January 2024, only Titanium rated PSUs are allowed to be shipped to European Union (EU), European Economic Area (EEA), United Kingdom (UK), Switzerland and other countries that adopted Lot 9 Regulation.
- DC PSUs are not impacted by Lot 9 Regulation and are EU/UK Lot 9 compliant

Table 14 Power Supply

Product ID (PID)	PID Description
PSU (Input High Line 210VAC)	
UCSC-PSU1-1200W	1200W Titanium power supply for C-Series Servers
UCSC-PSUV21050D	Cisco UCS 1050W -48V DC Power Supply for Rack Server
UCSC-PSU1-1600W	UCS 1600W AC PSU Platinum (Not EU/UK Lot 9 Compliant)
UCSC-PSU1-2300W	Cisco UCS 2300W AC Power Supply for Rack Servers Titanium
PSU (Input Low Line 110VAC)	
UCSC-PSU1-1200W	1200W Titanium power supply for C-Series Servers Titanium
UCSC-PSU1-2300W	2300W Power supply for C-series servers Titanium



NOTE:

- In a server with two power supplies, both power supplies must be identical.
- Refer to *Power Specifications, page 41* section for the full details on the each power supply.

STEP 12 SELECT INPUT POWER CORD(S) (REQUIRED)

Using [Table 15](#) and [Table 16](#), select the appropriate AC power cords. If you select the option NO-POWER-CORD, no power cord is shipped with the server.



NOTE: [Table 15](#) lists the power cords for servers that use power supplies less than 2300 W. [Table 16](#) lists the power cords for servers that use 2300 W power supplies. Note that the power cords for 2300 W power supplies use a C19 connector so they only fit the 2300 W power supply connector.

Table 15 Available Power Cords (for server PSUs less than 2300 W)

Product ID (PID)	PID Description	Images
NO-POWER-CORD	ECO friendly green option, no power cable will be shipped	
CAB-48DC-40A-8AWG	C-Series -48VDC PSU Power Cord, 3.5M, 3 Wire, 8AWG, 40A	
CAB-N5K6A-NA	Power Cord, 200/240V 6A, North America	
CAB-AC-L620-C13	AC Power Cord, NEMA L6-20 - C13, 2M/6.5ft	
CAB-C13-CBN	CABASY,WIRE,JUMPER CORD, 27" L, C13/C14, 10A/250V	
CAB-C13-C14-2M	CABASY,WIRE,JUMPER CORD, PWR, 2 Meter, C13/C14,10A/250V	

Table 15 Available Power Cords (for server PSUs less than 2300 W)

Product ID (PID)	PID Description	Images
CAB-C13-C14-AC	CORD,PWR,JMP,IEC60320/C14,IEC60320/C13, 3.0M	
CAB-250V-10A-AR	Power Cord, 250V, 10A, Argentina	
CAB-9K10A-AU	Power Cord, 250VAC 10A 3112 Plug, Australia	
CAB-250V-10A-CN	AC Power Cord - 250V, 10A - PRC	
CAB-9K10A-EU	Power Cord, 250VAC 10A CEE 7/7 Plug, EU	
CAB-250V-10A-ID	Power Cord, 250V, 10A, India	
CAB-C13-C14-3M-IN	Power Cord Jumper, C13-C14 Connectors, 3 Meter Length, India	Image not available
CAB-C13-C14-IN	Power Cord Jumper,C13-C14 Connectors,1.4 Meter Length, India	Image not available
CAB-250V-10A-IS	Power Cord, SFS, 250V, 10A, Israel	

Table 15 Available Power Cords (for server PSUs less than 2300 W)

Product ID (PID)	PID Description	Images
CAB-9K10A-IT	Power Cord, 250VAC 10A CEI 23-16/VII Plug, Italy	
CAB-9K10A-SW	Power Cord, 250VAC 10A MP232 Plug, Switzerland	
CAB-9K10A-UK	Power Cord, 250VAC 10A BS1363 Plug (13 A fuse), UK	
CAB-9K12A-NA ¹	Power Cord, 125VAC 13A NEMA 5-15 Plug, North America	
CAB-250V-10A-BR	Power Cord - 250V, 10A - Brazil	
CAB-C13-C14-2M-JP	Power Cord C13-C14, 2M/6.5ft Japan PSE mark	Image not available
CAB-9K10A-KOR ¹	Power Cord, 125VAC 13A KSC8305 Plug, Korea	Image not available
CAB-ACTW	AC Power Cord (Taiwan), C13, EL 302, 2.3M	Image not available
CAB-JPN-3PIN	Japan, 90-125VAC 12A NEMA 5-15 Plug, 2.4m	Image not available
CAB-48DC-40A-INT	C-Series -48VDC PSU PWR Cord, 3.5M, 3 Wire, 8AWG, 40A (INT)	Image not available
CAB-48DC-40A-ASD	C-Series -48VDC PSU PWR Cord, 3.5M, 3Wire, 8AWG, 40A (AS/NZ)	Image not available

Notes:

1. This power cord is rated to 125V and only supported for PSU rated at 1050W or less

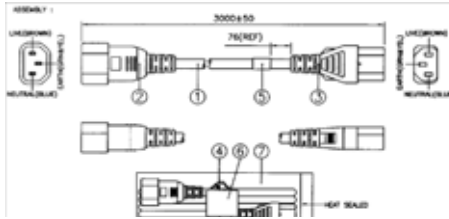
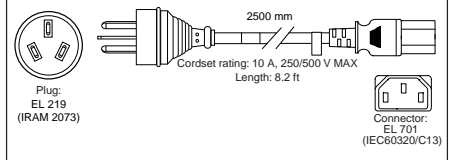
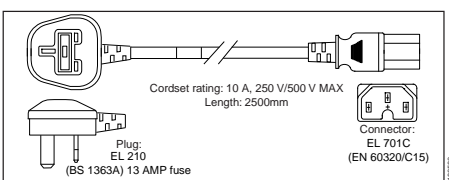
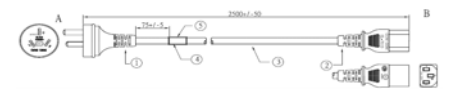
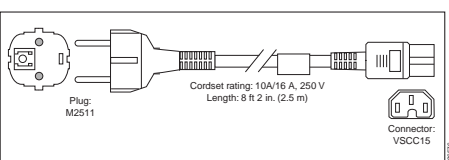
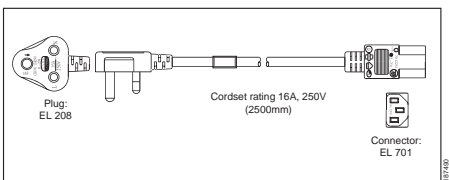
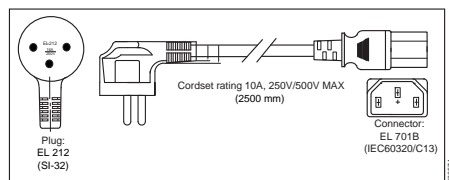
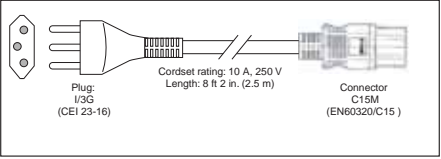
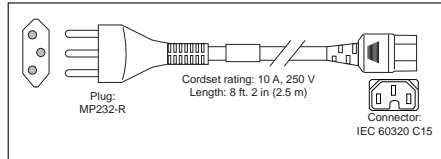
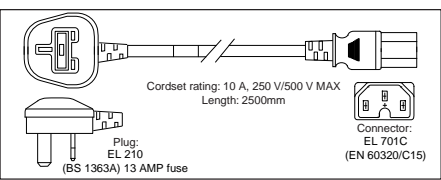
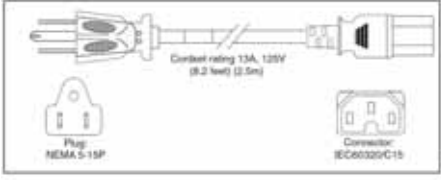
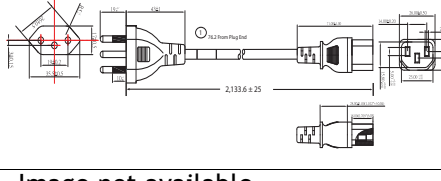
Table 16 Available Power Cords (for servers with 2300 W PSUs)

Product ID (PID)	PID Description	Images
CAB-C19-CBN	Cabinet Jumper Power Cord, 250 VAC 16A, C20-C19 Connectors	Not applicable
CAB-S132-C19-ISRL	S132 to IEC-C19 14ft Israeli	Image not available
CAB-IR2073-C19-AR	IRSM 2073 to IEC-C19 14ft Argen	Image not available
CAB-BS1363-C19-UK	BS-1363 to IEC-C19 14ft UK	Image not available
CAB-SABS-C19-IND	SABS 164-1 to IEC-C19 India	Image not available
CAB-C2316-C19-IT	CEI 23-16 to IEC-C19 14ft Italy	Image not available
CAB-US515P-C19-US	NEMA 5-15 to IEC-C19 13ft US	Image not available
CAB-US520-C19-US	NEMA 5-20 to IEC-C19 14ft US	Image not available
CAB-US620P-C19-US	NEMA 6-20 to IEC-C19 13ft US	Image not available
NO-POWER-CORD	ECO friendly green option, no power cable will be shipped	Image not available

STEP 13 ORDER TOOL-LESS RAIL KIT (REQUIRED) AND REVERSIBLE CABLE MANAGEMENT ARM (OPTIONAL)

■ Tool-less Rail Kit:

Select a tool-less rail kit (or no rail kit) from [Table 17](#).



NOTE:

- Cisco recommends a minimum quantity of 1 Rail Kit
- If you plan to rackmount your server, you must order a tool-less rail kit.

Table 17 Tool-less Rail Kit Options

Product ID (PID)	PID Description
UCSC-RAIL-M7	Ball Bearing Rail Kit for M8 servers
UCSC-RAIL-NONE	No rail kit option

■ Optional Reversible Cable Management Arm:

The reversible cable management arm mounts on either the right or left slide rails at the rear of the server and is used for cable management. Select an Optional Reversible Cable Management Arm from [Table 18](#).



NOTE: If you plan to rackmount your server, you must order a tool-less rail kit. The same rail kits and CMAs are used for M6 and M7 servers.

Table 18 Cable Management Arm

Product ID (PID)	PID Description
UCSC-CMA-C220-D	Reversible CMA for C220 M7/M8 ball bearing rail kit

For more information about the tool-less rail kit and cable management arm, Refer to [Cisco UCS C220 M8 Installation Guide](#) for the more information.

STEP 14 ORDER SECURITY DEVICES (REQUIRED)

A Trusted Platform Module (TPM) is a computer chip (microcontroller) that can securely store artifacts used to authenticate the platform (server). These artifacts can include passwords, certificates, or encryption keys. A TPM can also be used to store platform measurements that help ensure that the platform remains trustworthy. Authentication (ensuring that the platform can prove that it is what it claims to be) and attestation (a process helping to prove that a platform is trustworthy and has not been breached) are necessary steps to ensure safer computing in all environments.

A chassis intrusion switch gives a notification of any unauthorized mechanical access into the server.

The security device ordering information is listed in [Table 19](#)



NOTE:

- The TPM module used in this system conforms to TPM 2.0, as defined by the Trusted Computing Group (TCG). It is also SPI-based.
- TPM installation is supported after-factory. However, a TPM installs with a one-way screw and cannot be replaced, upgraded, or moved to another server. If a server with a TPM is returned, the replacement server must be ordered with a new TPM.

Table 19 Security Devices

Product ID (PID)	PID Description
UCSC-TPM-002D	TPM 2.0 TCG FIPS140-2 CC+ Cert M7/M8 Intel MSW2022 Compliant
UCSC-TPM-OPT-OUT	OPT OUT, TPM 2.0, TCG, FIPS140-2, CC EAL4+ Certified ¹
UCSC-INT-SW02	M8 Chassis Intrusion Switch

Notes:

1. Please note that Microsoft certification requires a TPM 2.0 for bare-metal or guest VM deployments. Opt-out of the TPM 2.0 voids the Microsoft certification

SUPPLEMENTAL MATERIAL

PCIe Port Assignment

Slots	CPU1	CPU2
Riser 1 (1A/1B)	Gen5 x16	
Riser 2 (2A)	Gen5 x16	
Riser 3 (3A / 3B)		Gen5 x16
mLOM / OCP	Gen4 x16	
SFF NVMe slots 1,2,3,4 ¹		Gen4 x4 each
SFF NVMe slots 6,7,8,9 ¹	Gen4 x4 each	
M.2 Boot RAID	Gen3 x2	

Notes:

1. NVMe Drives are connected directly to CPUs if not behind a Raid controller

Serial Port Details

Figure 6 Serial Port (Female RJ-45 Connector) Pinout
Serial Port (RJ-45 Female Connector)

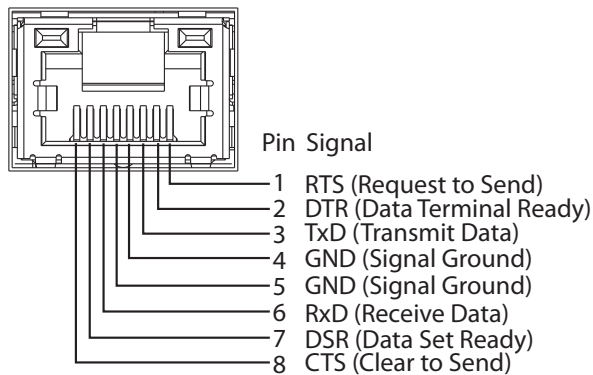

KVM Cable

The KVM cable provides a connection into the server, providing a DB9 serial connector, a VGA connector for a monitor, and dual USB ports for a keyboard and mouse. With this cable, you can create a direct connection to the operating system and the BIOS running on the server.

Table 20 KVM Cable

Product ID (PID)	PID Description
N20-BKVM	KVM cable for UCS Server console port

Figure 7 KVM Cable

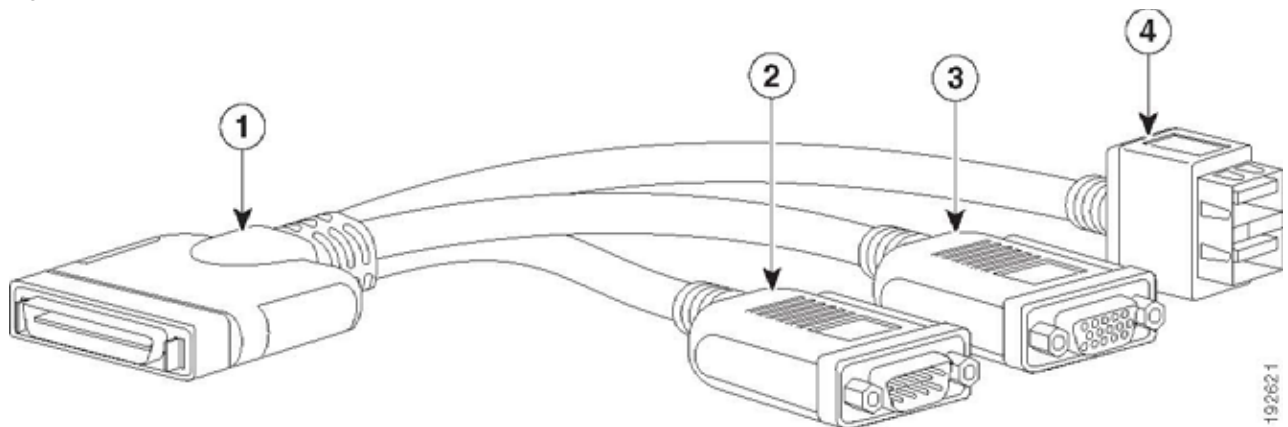

1	Connector (to server front panel)	3	VGA connector (for a monitor)
2	DB-9 serial connector	4	Two-port USB connector (for a mouse and keyboard)

TECHNICAL SPECIFICATIONS

Dimensions and Weight

Table 21 Dimensions and Weight

Parameter	Value
Height	3.42 in. (8.7 cm)
Width (including slam latches)	16.9 in.(42.9 cm)
Depth	30 in. (76.2 cm)
Weight	
0*2.5" HDDs, 0*CPU(w/o HS), 0*DIMM, 1*2300W PSU, 2*Raid tray, mLOM, riser cage 1(w/o PCIe), riser cage 2(w/o PCIe), riser cage 3(w/o PCIe)	19.47 kg = 42.92 lb
0*2.5" HDDs, 0*CPU(w/o HS), 0*DIMM, 1*2300W PSU, 2*Raid tray, mLOM, riser cage 1(w/o PCIe), riser cage 2(w/o PCIe), riser cage 3(w/o PCIe), Rail kit	23.23 kg = 51.21 lb
1*2.5" HDDs, 1*CPU(w/HS), 1*DIMM, 1*2300W PSU, 2*Raid tray, mLOM, riser cage 1(w/o PCIe), riser cage 2(w/o PCIe), riser cage 3(w/o PCIe)	20.31 kg = 44.78 lb
1*2.5" HDDs, 1*CPU(w/HS), 1*DIMM, 1*2300W PSU, 2*Raid tray, mLOM, riser cage 1(w/o PCIe), riser cage 2(w/o PCIe), riser cage 3(w/o PCIe), Rail kit	24.07 kg = 53.07 lb
24*2.5" HDDs, 2*CPU(w/HS), 32*DIMM, 2*2300W PSU, 2*Raid tray, mLOM, riser cage 1(w/o PCIe), riser cage 2(w/o PCIe), riser cage 3(w/o PCIe)	28.96 kg = 63.85 lb
24*2.5" HDDs, 2*CPU(w/HS), 32*DIMM, 2*2300W PSU, 2*Raid tray, mLOM, riser cage 1(w/o PCIe), riser cage 2(w/o PCIe), riser cage 3(w/o PCIe), Rail kit	32.72 kg = 72.14 lb

Dimensions and Weight

Table 22 Server Dimensions and Weight

Parameter	Value
Height	1.70 in. (4.3 cm)
Width (including slam latches)	16.9 in. (42.9 cm)
Depth	30 in. (76.2 cm)
Weight	
0*2.5" HDDs, 0*CPU(w/o HS), 0*DIMM, 1*2300W PSU, 2FH riser 1(w/o PCIe), 2FH riser 2(w/o PCIe), BBU+M.2 module, mLOM, Raid tray	14.22 kg = 31.35 lb
0*2.5" HDDs, 0*CPU(w/o HS), 0*DIMM, 1*2300W PSU, 2FH riser 1(w/o PCIe), 2FH riser 2(w/o PCIe), BBU+M.2 module, mLOM, Raid tray, Rail kit	17.98 kg = 39.64 lb
1*2.5" HDDs, 1*CPU(w/HS), 1*DIMM, 1*2300W PSU, 2FH riser 1(w/o PCIe), 2FH riser 2(w/o PCIe), BBU+M.2 module, mLOM, Raid tray	15.09 kg = 33.27 lb
1*2.5" HDDs, 1*CPU(w/HS), 1*DIMM, 1*2300W PSU, 2FH riser 1(w/o PCIe), 2FH riser 2(w/o PCIe), BBU+M.2 module, mLOM, Raid tray, Rail kit	18.85 kg = 41.56 lb
10*2.5" HDDs, 2*CPU(w/HS), 32*DIMM, 2*2300W PSU, 2FH riser 1(w/o PCIe), 2FH riser 2(w/o PCIe), BBU+M.2 module, mLOM, Raid tray	19.84 kg = 43.74 lb
10*2.5" HDDs, 2*CPU(w/HS), 32*DIMM, 2*2300W PSU, 2FH riser 1(w/o PCIe), 2FH riser 2(w/o PCIe), BBU+M.2 module, mLOM, Raid tray, Rail kit	23.60 kg = 52.03 lb

Power Specifications

The server is available with the following types of power supplies:

- 1050W (DC) power supply (see [Table 23](#))
- 1200 W (AC) power supply (see [Table 24](#))
- 1600 W (AC) power supply (see [Table 25](#))
- 2300 W (AC) power supply (see [Table 26](#))

Table 23 1050W (DC) Power Supply Specifications

Parameter	Specification
Input Connector	Molex 42820
Input Voltage Range (V rms)	-48
Maximum Allowable Input Voltage Range (V rms)	-40 to -72
Frequency Range (Hz)	NA
Maximum Allowable Frequency Range (Hz)	NA
Maximum Rated Output (W)	1050
Maximum Rated Standby Output (W)	36
Nominal Input Voltage (V rms)	-48
Nominal Input Current (A rms)	24
Maximum Input at Nominal Input Voltage (W)	1154
Maximum Input at Nominal Input Voltage (VA)	1154
Minimum Rated Efficiency (%) ¹	91
Minimum Rated Power Factor ¹	NA
Maximum Inrush Current (A peak)	15
Maximum Inrush Current (ms)	0.2
Minimum Ride-Through Time (ms) ²	5

Notes:

1. This is the minimum rating required to achieve 80 PLUS Platinum certification, see test reports published at <http://www.80plus.org/> for certified values
2. Time output voltage remains within regulation limits at 100% load, during input voltage dropout

Table 24 1200 W (AC) Power Supply Specifications

Parameter	Specification			
Input Connector	IEC320 C14			
Input Voltage Range (Vrms)	100 to 240			
Maximum Allowable Input Voltage Range (Vrms)	90 to 264			
Frequency Range (Hz)	50 to 60			
Maximum Allowable Frequency Range (Hz)	47 to 63			
Maximum Rated Output (W) ¹	1100	1200		
Maximum Rated Standby Output (W)	48			
Nominal Input Voltage (Vrms)	100	120	208	230
Nominal Input Current (Arms)	12.97	10.62	6.47	5.84
Maximum Input at Nominal Input Voltage (W)	1300	1264	1343	1340
Maximum Input at Nominal Input Voltage (VA)	1300	1266	1345	1342
Minimum Rated Efficiency (%) ²	90	90	91	91
Minimum Rated Power Factor ²	0.97	0.97	0.97	0.97
Maximum Inrush Current (A peak)	20			
Maximum Inrush Current (ms)	0.2			
Minimum Ride-Through Time (ms) ³	12			

Notes:

1. Maximum rated output is limited to 1100W when operating at low-line input voltage (100-127V)
2. This is the minimum rating required to achieve 80 PLUS Titanium certification, see test reports published at <http://www.80plus.org/> for certified values
3. Time output voltage remains within regulation limits at 100% load, during input voltage dropout

Table 25 1600 W (AC) Power Supply Specifications

Parameter	Specification			
Input Connector	IEC320 C14			
Input Voltage Range (V rms)	200 to 240			
Maximum Allowable Input Voltage Range (V rms)	180 to 264			
Frequency Range (Hz)	50 to 60			
Maximum Allowable Frequency Range (Hz)	47 to 63			
Maximum Rated Output (W)	1600			
Maximum Rated Standby Output (W)	36			
Nominal Input Voltage (V rms)	100	120	208	230
Nominal Input Current (A rms)	NA	NA	8.8	7.9
Maximum Input at Nominal Input Voltage (W)	NA	NA	1778	1758
Maximum Input at Nominal Input Voltage (VA)	NA	NA	1833	1813
Minimum Rated Efficiency (%) ¹	NA	NA	90	91
Minimum Rated Power Factor ²	NA	NA	0.97	0.97
Maximum Inrush Current (A peak)	30			
Maximum Inrush Current (ms)	0.2			
Minimum Ride-Through Time (ms) ²	12			

Notes:

1. This is the minimum rating required to achieve 80 PLUS Platinum certification, see test reports published at <http://www.80plus.org/> for certified values
2. Time output voltage remains within regulation limits at 100% load, during input voltage dropout

Table 26 2300 W (AC) Power Supply Specifications

Parameter	Specification			
Input Connector	IEC320 C20			
Input Voltage Range (Vrms)	100 to 240			
Maximum Allowable Input Voltage Range (Vrms)	90 to 264			
Frequency Range (Hz)	50 to 60			
Maximum Allowable Frequency Range (Hz)	47 to 63			
Maximum Rated Output (W) ¹	2300			
Maximum Rated Standby Output (W)	36			
Nominal Input Voltage (Vrms)	100	120	208	230
Nominal Input Current (Arms)	13	11	12	10.8
Maximum Input at Nominal Input Voltage (W)	1338	1330	2490	2480
Maximum Input at Nominal Input Voltage (VA)	1351	1343	2515	2505
Minimum Rated Efficiency (%) ²	92	92	93	93
Minimum Rated Power Factor ²	0.99	0.99	0.97	0.97
Maximum Inrush Current (A peak)	30			
Maximum Inrush Current (ms)	0.2			
Minimum Ride-Through Time (ms) ³	12			

Notes:

1. Maximum rated output is limited to 1200W when operating at low-line input voltage (100-127V)
2. This is the minimum rating required to achieve 80 PLUS Titanium certification, see test reports published at <http://www.80plus.org/> for certified values
3. Time output voltage remains within regulation limits at 100% load, during input voltage dropout



NOTE: For configuration-specific power specifications, use the Cisco UCS Power Calculator at this URL: <http://ucspowercalc.cisco.com>

Compliance Requirements

The regulatory compliance requirements for C-Series servers are listed in [Table 27](#).

Table 27 UCS C-Series Regulatory Compliance Requirements

Parameter	Description
Regulatory Compliance	Products should comply with CE Markings per directives 2014/30/EU and 2014/35/EU
Safety	UL 60950-1/62368-1 CAN/CSA-C22.2 No. 60950-1/62368-1 IEC/EN 60950-1/62368-1 AS/NZS 62368.1 GB 4943.1-2022 CNS 15598-1:2020
EMC - Emissions	47CFR Part 15 (CFR 47) Class A AS/NZS CISPR32 Class A CISPR32 Class A EN55032 Class A ICES003 Class A VCCI-CISPR32 Class A EN61000-3-2 EN61000-3-3 KS C 9832 Class A EN 300386 Class A
EMC - Immunity	EN55035 EN55024 CISPR24/35 EN300386 KS C 9835 IEC/EN61000-6-1



Americas Headquarters
Cisco Systems, Inc.
San Jose, CA

Asia Pacific Headquarters
Cisco Systems (USA) Pte. Ltd.
Singapore

Europe Headquarters
Cisco Systems International BV Amsterdam,
The Netherlands

Cisco has more than 200 offices worldwide. Addresses, phone numbers, and fax numbers are listed on the Cisco Website at www.cisco.com/go/offices.

Cisco and the Cisco Logo are trademarks of Cisco Systems, Inc. and/or its affiliates in the U.S. and other countries. A listing of Cisco's trademarks can be found at www.cisco.com/go/trademarks. Third party trademarks mentioned are the property of their respective owners. The use of the word partner does not imply a partnership relationship between Cisco and any other company. (01/2015)

