



IP Multicast Routing Configuration Guide, Cisco IOS Release 15.2(2)E (Cisco IE 3000 Switches)

First Published: June 27, 2014

Americas Headquarters

Cisco Systems, Inc.
170 West Tasman Drive
San Jose, CA 95134-1706
USA
<http://www.cisco.com>
Tel: 408 526-4000
800 553-NETS (6387)
Fax: 408 527-0883

Text Part Number: OL-32532-01

THE SPECIFICATIONS AND INFORMATION REGARDING THE PRODUCTS IN THIS MANUAL ARE SUBJECT TO CHANGE WITHOUT NOTICE. ALL STATEMENTS, INFORMATION, AND RECOMMENDATIONS IN THIS MANUAL ARE BELIEVED TO BE ACCURATE BUT ARE PRESENTED WITHOUT WARRANTY OF ANY KIND, EXPRESS OR IMPLIED. USERS MUST TAKE FULL RESPONSIBILITY FOR THEIR APPLICATION OF ANY PRODUCTS.

THE SOFTWARE LICENSE AND LIMITED WARRANTY FOR THE ACCOMPANYING PRODUCT ARE SET FORTH IN THE INFORMATION PACKET THAT SHIPPED WITH THE PRODUCT AND ARE INCORPORATED HEREIN BY THIS REFERENCE. IF YOU ARE UNABLE TO LOCATE THE SOFTWARE LICENSE OR LIMITED WARRANTY, CONTACT YOUR CISCO REPRESENTATIVE FOR A COPY.

The Cisco implementation of TCP header compression is an adaptation of a program developed by the University of California, Berkeley (UCB) as part of UCB's public domain version of the UNIX operating system. All rights reserved. Copyright © 1981, Regents of the University of California.

NOTWITHSTANDING ANY OTHER WARRANTY HEREIN, ALL DOCUMENT FILES AND SOFTWARE OF THESE SUPPLIERS ARE PROVIDED "AS IS" WITH ALL FAULTS. CISCO AND THE ABOVE-NAMED SUPPLIERS DISCLAIM ALL WARRANTIES, EXPRESSED OR IMPLIED, INCLUDING, WITHOUT LIMITATION, THOSE OF MERCHANTABILITY, FITNESS FOR A PARTICULAR PURPOSE AND NONINFRINGEMENT OR ARISING FROM A COURSE OF DEALING, USAGE, OR TRADE PRACTICE.

IN NO EVENT SHALL CISCO OR ITS SUPPLIERS BE LIABLE FOR ANY INDIRECT, SPECIAL, CONSEQUENTIAL, OR INCIDENTAL DAMAGES, INCLUDING, WITHOUT LIMITATION, LOST PROFITS OR LOSS OR DAMAGE TO DATA ARISING OUT OF THE USE OR INABILITY TO USE THIS MANUAL, EVEN IF CISCO OR ITS SUPPLIERS HAVE BEEN ADVISED OF THE POSSIBILITY OF SUCH DAMAGES.

Any Internet Protocol (IP) addresses and phone numbers used in this document are not intended to be actual addresses and phone numbers. Any examples, command display output, network topology diagrams, and other figures included in the document are shown for illustrative purposes only. Any use of actual IP addresses or phone numbers in illustrative content is unintentional and coincidental.

Cisco and the Cisco logo are trademarks or registered trademarks of Cisco and/or its affiliates in the U.S. and other countries. To view a list of Cisco trademarks, go to this URL: <http://www.cisco.com/go/trademarks>. Third-party trademarks mentioned are the property of their respective owners. The use of the word partner does not imply a partnership relationship between Cisco and any other company. (1110R)

© 2014 Cisco Systems, Inc. All rights reserved.



CONTENTS

Preface

Preface **xiii**

Document Conventions **xiii**

Related Documentation **xv**

Obtaining Documentation and Submitting a Service Request **xv**

CHAPTER 1

IP Multicast Routing Technology Overview **1**

Finding Feature Information **1**

Information About IP Multicast Technology **1**

Role of IP Multicast in Information Delivery **1**

IP Multicast Routing Protocols **2**

Multicast Group Transmission Scheme **2**

IP Multicast Boundary **4**

IP Multicast Group Addressing **5**

IP Class D Addresses **5**

IP Multicast Address Scoping **5**

Layer 2 Multicast Addresses **7**

IP Multicast Delivery Modes **7**

Source Specific Multicast **7**

Additional References **8**

CHAPTER 2

Configuring IGMP **11**

Finding Feature Information **11**

Prerequisites for IGMP **11**

Restrictions for Configuring IGMP **12**

Information About IGMP **12**

Role of the Internet Group Management Protocol **12**

IGMP Multicast Addresses **13**

IGMP Versions	13
IGMP Version 1	13
IGMP Version 2	13
IGMP Version 3	14
IGMPv3 Host Signalling	14
IGMP Versions Differences	14
IGMP Join and Leave Process	16
IGMP Join Process	16
IGMP Leave Process	17
Default IGMP Configuration	18
How to Configure IGMP	18
Configuring the Switch as a Member of a Group	18
Controlling Access to IP Multicast Group	20
Changing the IGMP Version	22
Modifying the IGMP Host-Query Message Interval	24
Changing the IGMP Query Timeout for IGMPv2	26
Changing the Maximum Query Response Time for IGMPv2	28
Configuring the Switch as a Statically Connected Member	30
Monitoring IGMP	31
Configuration Examples for IGMP	32
Example: Configuring the Switch as a Member of a Multicast Group	32
Example: Controlling Access to IP Multicast Groups	33
Additional References	33

CHAPTER 3**Configuring CGMP 35**

Finding Feature Information	35
Prerequisites for Configuring CGMP	35
Restrictions for CGMP	35
Information About CGMP	36
Enabling CGMP Server Support	36
Monitoring CGMP	38
Additional References	39

CHAPTER 4**Configuring PIM 41**

Finding Feature Information	41
-----------------------------	----

Prerequisites for PIM	41
Restrictions for PIM	42
PIMv1 and PIMv2 Interoperability	42
Restrictions for Configuring PIM Stub Routing	43
Restrictions for Configuring Auto-RP and BSR	43
Information About PIM	44
Protocol Independent Multicast	44
PIM Dense Mode	45
PIM Sparse Mode	45
Sparse-Dense Mode	46
PIM Versions	47
PIM Stub Routing	47
IGMP Helper	48
Rendezvous Points	49
Auto-RP	49
Sparse-Dense Mode for Auto-RP	50
Bootstrap Router	50
PIM Domain Border	51
Multicast Forwarding	51
Multicast Distribution Source Tree	51
Multicast Distribution Shared Tree	52
Source Tree Advantage	53
Shared Tree Advantage	53
PIM Shared Tree and Source Tree	54
Reverse Path Forwarding	55
RPF Check	56
Default PIM Routing Configuration	57
How to Configure PIM	58
Enabling PIM Stub Routing	58
Configuring a Rendezvous Point	60
Manually Assigning an RP to Multicast Groups	60
Setting Up Auto-RP in a New Internetwork	62
Adding Auto-RP to an Existing Sparse-Mode Cloud	65
Configuring Sparse Mode with a Single Static RP	68
Preventing Join Messages to False RPs	70

Filtering Incoming RP Announcement Messages	71
Configuring PIMv2 BSR	73
Defining the PIM Domain Border	73
Defining the IP Multicast Boundary	75
Configuring Candidate BSRs	78
Configuring the Candidate RPs	79
Delaying the Use of PIM Shortest-Path Tree	81
Modifying the PIM Router-Query Message Interval	83
Verifying PIM Operations	85
Verifying IP Multicast Operation in a PIM-SM or a PIM-SSM Network	85
Verifying IP Multicast on the First Hop Router	86
Verifying IP Multicast on Routers Along the SPT	87
Verifying IP Multicast Operation on the Last Hop Router	88
Using PIM-Enabled Routers to Test IP Multicast Reachability	91
Configuring Routers to Respond to Multicast Pings	91
Pinging Routers Configured to Respond to Multicast Pings	92
Monitoring and Troubleshooting PIM	93
Monitoring PIM Information	93
Monitoring the RP Mapping and BSR Information	93
Troubleshooting PIMv1 and PIMv2 Interoperability Problems	94
Configuration Examples for PIM	94
Example: Enabling PIM Stub Routing	94
Example: Verifying PIM Stub Routing	95
Example: Manually Assigning an RP to Multicast Groups	95
Example: Configuring Auto-RP	96
Example: Defining the IP Multicast Boundary to Deny Auto-RP Information	96
Example: Filtering Incoming RP Announcement Messages	96
Example: Preventing Join Messages to False RPs	97
Example: Configuring Candidate BSRs	97
Example: Configuring Candidate RPs	97
Additional References	98

CHAPTER 5**Configuring HSRP Aware PIM 101**

HSRP Aware PIM 101

Finding Feature Information 101

Restrictions for HSRP Aware PIM	101
Information About HSRP Aware PIM	102
HSRP	102
HSRP Aware PIM	102
How to Configure HSRP Aware PIM	103
Configuring an HSRP Group on an Interface	103
Configuring PIM Redundancy	105
Configuration Examples for HSRP Aware PIM	106
Example: Configuring an HSRP Group on an Interface	106
Example: Configuring PIM Redundancy	107
Additional References for HSRP Aware PIM	107
Feature Information for HSRP Aware PIM	108

CHAPTER 6**Configuring VRRP Aware PIM 109**

VRRP Aware PIM	109
Finding Feature Information	109
Restrictions for VRRP Aware PIM	109
Information About VRRP Aware PIM	110
Overview of VRRP Aware PIM	110
How to Configure VRRP Aware PIM	111
Configuring VRRP Aware PIM	111
Configuration Examples for VRRP Aware PIM	113
Example: VRRP Aware PIM	113
Additional References for VRRP Aware PIM	113

CHAPTER 7**Configuring Basic IP Multicast Routing 115**

Finding Feature Information	115
Prerequisites for Basic IP Multicast Routing	115
Restrictions for Basic IP Multicast Routing	116
Information About Basic IP Multicast Routing	116
Multicast Routing and Switch Stacks	116
Default IP Multicast Routing Configuration	117
sdr Listener Support	117
How to Configure Basic IP Multicast Routing	118
Configuring Basic IP Multicast Routing	118

Configuring Optional IP Multicast Routing Features	121
Defining the IP Multicast Boundary	121
Configuring Multicast VRFs	123
Advertising Multicast Multimedia Sessions Using SAP Listener	125
Monitoring and Maintaining Basic IP Multicast Routing	126
Clearing Caches, Tables, and Databases	126
Displaying System and Network Statistics	127
Displaying Multicast Peers, Packet Rates and Loss Information, and Path Tracing	128
Additional References	129

CHAPTER 8**Configuring SSM 131**

Finding Feature Information	131
Prerequisites for Configuring SSM	131
Restrictions for Configuring SSM	132
Information About SSM and SSM Mapping	133
SSM Components Overview	133
How SSM Differs from Internet Standard Multicast	133
SSM Operations	134
IGMPv3 Host Signaling	135
Benefits of SSM	135
SSM Mapping Overview	136
Static SSM Mapping	137
DNS-Based SSM Mapping	137
SSM Mapping Benefits	138
How to Configure SSM and SSM Mapping	139
Configuring SSM	139
Configuring SSM Mapping	141
Configuring Static SSM Mapping	141
Configuring DNS-Based SSM Mapping	143
Configuring Static Traffic Forwarding with SSM Mapping	145
Verifying SSM Mapping Configuration and Operation	147
Monitoring SSM and SSM Mapping	149
Monitoring SSM	149
Monitoring SSM Mapping	149
Configuration Examples for SSM and SSM Mapping	150

SSM with IGMPv3 Example	150
SSM Filtering Example	150
SSM Mapping Example	151
DNS Server Configuration Example	154
Additional References	154

CHAPTER 9**Configuring IGMP Snooping and Multicast VLAN Registration 157**

Finding Feature Information	157
Prerequisites for Configuring IGMP Snooping and MVR	157
Prerequisites for IGMP Snooping	157
Restrictions for Configuring IGMP Snooping and MVR	158
Restrictions for IGMP Snooping	158
Restrictions for MVR	159
Information About IGMP Snooping and MVR	160
IGMP Snooping	160
IGMP Versions	161
Joining a Multicast Group	161
Leaving a Multicast Group	163
Immediate Leave	163
IGMP Configurable-Leave Timer	163
IGMP Report Suppression	164
Default IGMP Snooping Configuration	164
Multicast VLAN Registration	165
MVR and IGMP	165
Modes of Operation	165
MVR in a Multicast Television Application	166
Default MVR Configuration	167
IGMP Filtering and Throttling	167
Default IGMP Filtering and Throttling Configuration	168
How to Configure IGMP Snooping and MVR	169
Enabling or Disabling IGMP Snooping on a Switch	169
Enabling or Disabling IGMP Snooping on a VLAN Interface	170
Setting the Snooping Method	171
Configuring a Multicast Router Port	173
Configuring a Host Statically to Join a Group	174

Enabling IGMP Immediate Leave	176
Configuring the IGMP Leave Timer	178
Configuring TCN-Related Commands	179
Controlling the Multicast Flooding Time After a TCN Event	179
Recovering from Flood Mode	181
Disabling Multicast Flooding During a TCN Event	182
Configuring the IGMP Snooping Querier	184
Disabling IGMP Report Suppression	186
Configuring MVR Global Parameters	187
Configuring MVR Interfaces	190
Configuring IGMP Profiles	192
Applying IGMP Profiles	195
Setting the Maximum Number of IGMP Groups	196
Configuring the IGMP Throttling Action	198
Monitoring IGMP Snooping and MVR	200
Monitoring IGMP Snooping Information	200
Monitoring MVR	201
Monitoring IGMP Filtering and Throttling Configuration	202
Configuration Examples for IGMP Snooping and MVR	203
Example: Configuring IGMP Snooping Using CGMP Packets	203
Example: Enabling a Static Connection to a Multicast Router	203
Example: Configuring a Host Statically to Join a Group	203
Example: Enabling IGMP Immediate Leave	203
Example: Setting the IGMP Snooping Querier Source Address	204
Example: Setting the IGMP Snooping Querier Maximum Response Time	204
Example: Setting the IGMP Snooping Querier Timeout	204
Example: Setting the IGMP Snooping Querier Feature	204
Example: Configuring IGMP Profiles	205
Example: Applying IGMP Profile	205
Example: Setting the Maximum Number of IGMP Groups	205
Example: Configuring MVR Global Parameters	205
Example: Configuring MVR Interfaces	205
Additional References	206

Finding Feature Information	209
209	
Information About Multicast Source Discovery Protocol	209
209	
MSDP Benefits	212
Default MSDP Peers	212
MSDP Mesh Groups	213
Benefits of MSDP Mesh Groups	214
SA Origination Filters	214
Use of Outgoing Filter Lists in MSDP	214
Use of Incoming Filter Lists in MSDP	215
TTL Thresholds in MSDP	216
MSDP Message Types	216
SA Messages	216
SA Request Messages	217
SA Response Messages	217
Keepalive Messages	217
Default MSDP Configuration	217
How to Configure MSDP	217
Configuring a Default MSDP Peer	217
Caching Source-Active State	219
Requesting Source Information from an MSDP Peer	220
Controlling Source Information that Your Switch Originates	221
Redistributing Sources	222
Filtering Source-Active Request Messages	223
Controlling Source Information that Your Switch Forwards	225
Using a Filter	225
Using TTL to Limit the Multicast Data Sent in SA Messages	227
Controlling Source Information that Your Switch Receives	228
Configuring an MSDP Mesh Group	230
Shutting Down an MSDP Peer	231
Including a Bordering PIM Dense-Mode Region in MSDP	233
Configuring an Originating Address other than the RP Address	234
Monitoring and Maintaining MSDP	236
Monitoring MSDP	236

Clearing MSDP Connections Statistics and SA Cache Entries	238
Configuration Examples for Configuring MSDP	239
Configuring a Default MSDP Peer: Example	239
Caching Source-Active State: Example	240
Requesting Source Information from an MSDP Peer: Example	240
Controlling Source Information that Your Switch Originates: Example	240
Controlling Source Information that Your Switch Forwards: Example	240
Controlling Source Information that Your Switch Receives: Example	240
Example: Configuring MSDP Mesh Groups	240
Requesting Source Information from an MSDP Peer: Example	241
Additional References	241



Preface

This book describes configuration information and examples for IP multicast routing on the switch.

- [Document Conventions](#), page [xiii](#)
- [Related Documentation](#), page [xv](#)
- [Obtaining Documentation and Submitting a Service Request](#), page [xv](#)

Document Conventions

This document uses the following conventions:

Convention	Description
<code>^</code> or <code>Ctrl</code>	Both the <code>^</code> symbol and <code>Ctrl</code> represent the Control (<code>Ctrl</code>) key on a keyboard. For example, the key combination <code>^D</code> or <code>Ctrl-D</code> means that you hold down the Control key while you press the <code>D</code> key. (Keys are indicated in capital letters but are not case sensitive.)
bold font	Commands and keywords and user-entered text appear in bold font .
<i>Italic font</i>	Document titles, new or emphasized terms, and arguments for which you supply values are in <i>italic font</i> .
<code>Courier font</code>	Terminal sessions and information the system displays appear in <code>courier font</code> .
Bold Courier font	Bold Courier font indicates text that the user must enter.
[x]	Elements in square brackets are optional.
...	An ellipsis (three consecutive nonbolded periods without spaces) after a syntax element indicates that the element can be repeated.
	A vertical line, called a pipe, indicates a choice within a set of keywords or arguments.

Convention	Description
[x y]	Optional alternative keywords are grouped in brackets and separated by vertical bars.
{x y}	Required alternative keywords are grouped in braces and separated by vertical bars.
[x {y z}]	Nested set of square brackets or braces indicate optional or required choices within optional or required elements. Braces and a vertical bar within square brackets indicate a required choice within an optional element.
string	A nonquoted set of characters. Do not use quotation marks around the string or the string will include the quotation marks.
<>	Nonprinting characters such as passwords are in angle brackets.
[]	Default responses to system prompts are in square brackets.
!, #	An exclamation point (!) or a pound sign (#) at the beginning of a line of code indicates a comment line.

Reader Alert Conventions

This document may use the following conventions for reader alerts:



Note

Means *reader take note*. Notes contain helpful suggestions or references to material not covered in the manual.



Tip

Means *the following information will help you solve a problem*.



Caution

Means *reader be careful*. In this situation, you might do something that could result in equipment damage or loss of data.



Timesaver

Means *the described action saves time*. You can save time by performing the action described in the paragraph.

**Warning****IMPORTANT SAFETY INSTRUCTIONS**

This warning symbol means danger. You are in a situation that could cause bodily injury. Before you work on any equipment, be aware of the hazards involved with electrical circuitry and be familiar with standard practices for preventing accidents. Use the statement number provided at the end of each warning to locate its translation in the translated safety warnings that accompanied this device. Statement 1071

SAVE THESE INSTRUCTIONS

Related Documentation

**Note**

Before installing or upgrading the switch, refer to the switch release notes.

- Cisco Industrial Ethernet 3000 Series Switch documentation, located at:
<http://www.cisco.com/c/en/us/support/switches/industrial-ethernet-3000-series-switches/tsd-products-support-series-home.html>
- Cisco SFP module documentation, including compatibility matrixes, located at:
http://www.cisco.com/en/US/products/hw/modules/ps5455/tsd_products_support_series_home.html
- Error Message Decoder, located at:
<https://www.cisco.com/cgi-bin/Support/Errordecoder/index.cgi>

Obtaining Documentation and Submitting a Service Request

For information on obtaining documentation, submitting a service request, and gathering additional information, see the monthly *What's New in Cisco Product Documentation*, which also lists all new and revised Cisco technical documentation, at:

<http://www.cisco.com/c/en/us/td/docs/general/whatsnew/whatsnew.html>

Subscribe to the *What's New in Cisco Product Documentation* as a Really Simple Syndication (RSS) feed and set content to be delivered directly to your desktop using a reader application. The RSS feeds are a free service and Cisco currently supports RSS version 2.0.



CHAPTER

1

IP Multicast Routing Technology Overview

- [Finding Feature Information, page 1](#)
- [Information About IP Multicast Technology, page 1](#)
- [Additional References, page 8](#)

Finding Feature Information

Your software release may not support all the features documented in this module. For the latest caveats and feature information, see [Bug Search Tool](#) and the release notes for your platform and software release. To find information about the features documented in this module, and to see a list of the releases in which each feature is supported, see the feature information table at the end of this module.

Use Cisco Feature Navigator to find information about platform support and Cisco software image support. To access Cisco Feature Navigator, go to www.cisco.com/go/cfn. An account on Cisco.com is not required.

Information About IP Multicast Technology

Role of IP Multicast in Information Delivery

IP multicast is a bandwidth-conserving technology that reduces traffic by delivering a single stream of information simultaneously to potentially thousands of businesses and homes. Applications that take advantage of multicast include video conferencing, corporate communications, distance learning, and distribution of software, stock quotes, and news.

IP multicast routing enables a host (source) to send packets to a group of hosts (receivers) anywhere within the IP network by using a special form of IP address called the IP multicast group address. The sending host inserts the multicast group address into the IP destination address field of the packet and IP multicast routers and multilayer switches forward incoming IP multicast packets out all interfaces that lead to the members of the multicast group. Any host, regardless of whether it is a member of a group, can send to a group. However, only the members of a group receive the message.

IP Multicast Routing Protocols

The software supports the following protocols to implement IP multicast routing:

- IGMP is used between hosts on a LAN and the routers (and multilayer switches) on that LAN to track the multicast groups of which hosts are members. To participate in IP multicasting, multicast hosts, routers, and multilayer switches must have the Internet Group Management Protocol (IGMP) operating.
- Protocol Independent Multicast (PIM) is used between routers so that they can track which multicast packets to forward to each other and to their directly connected LANs.

This figure shows where these protocols operate within the IP multicast environment.

Figure 1: IP Multicast Routing Protocols

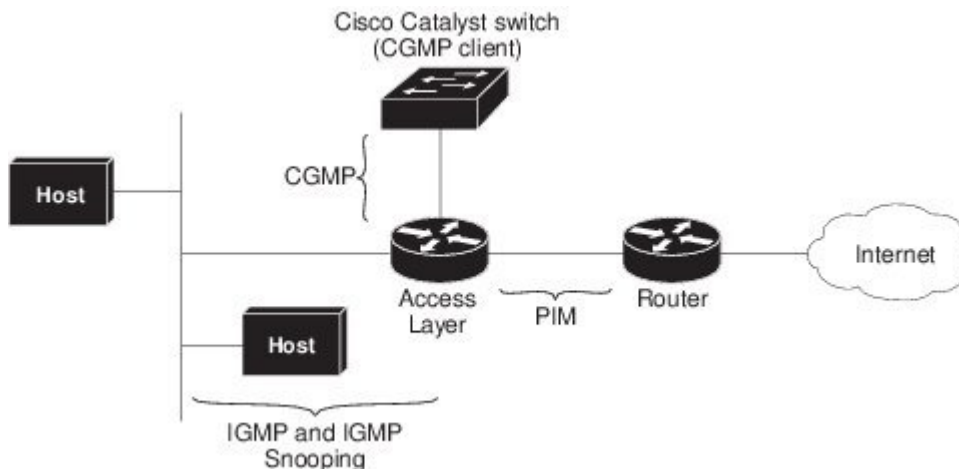

According to IPv4 multicast standards, the MAC destination multicast address begins with 0100:5e and is appended by the last 23 bits of the IP address. For example, if the IP destination address is 239.1.1.39, the MAC destination address is 0100:5e01:0127.

A multicast packet is unmatched when the destination IPv4 address does not match the destination MAC address. The switch forwards the unmatched packet in hardware based upon the MAC address table. If the destination MAC address is not in the MAC address table, the switch floods the packet to the all port in the same VLAN as the receiving port.

Multicast Group Transmission Scheme

IP communication consists of hosts that act as senders and receivers of traffic as shown in the first figure. Senders are called sources. Traditional IP communication is accomplished by a single host source sending packets to another single host (unicast transmission) or to all hosts (broadcast transmission). IP multicast provides a third scheme, allowing a host to send packets to a subset of all hosts (multicast transmission). This subset of receiving hosts is called a multicast group. The hosts that belong to a multicast group are called group members.

Multicast is based on this group concept. A multicast group is an arbitrary number of receivers that join a group in order to receive a particular data stream. This multicast group has no physical or geographical

boundaries--the hosts can be located anywhere on the Internet or on any private internetwork. Hosts that are interested in receiving data from a source to a particular group must join that group. Joining a group is accomplished by a host receiver by way of the Internet Group Management Protocol (IGMP).

In a multicast environment, any host, regardless of whether it is a member of a group, can send to a group. However, only the members of a group can receive packets sent to that group. Multicast packets are delivered to a group using best-effort reliability, just like IP unicast packets.

Unicast transmission—One host sends and the other receives.



Broadcast transmission—One sender to all receivers.

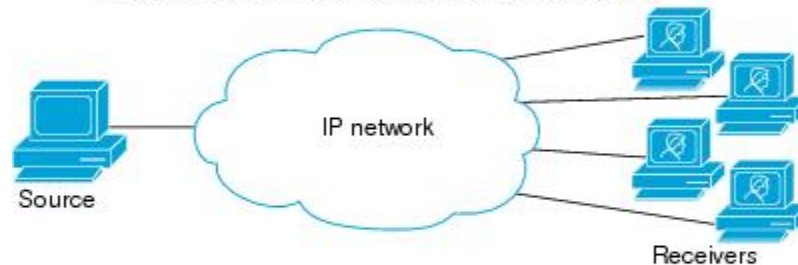

Multicast transmission—One sender to a group of receivers.

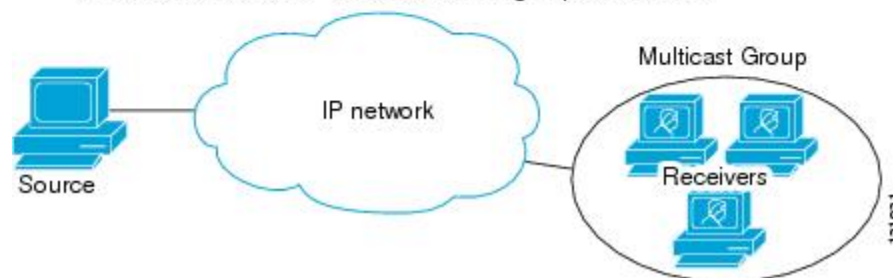

In the next figure, the receivers (the designated multicast group) are interested in receiving the video data stream from the source. The receivers indicate their interest by sending an IGMP host report to the routers in the network. The routers are then responsible for delivering the data from the source to the receivers. The routers use Protocol Independent Multicast (PIM) to dynamically create a multicast distribution tree. The video data stream will then be delivered only to the network segments that are in the path between the source and the receivers.

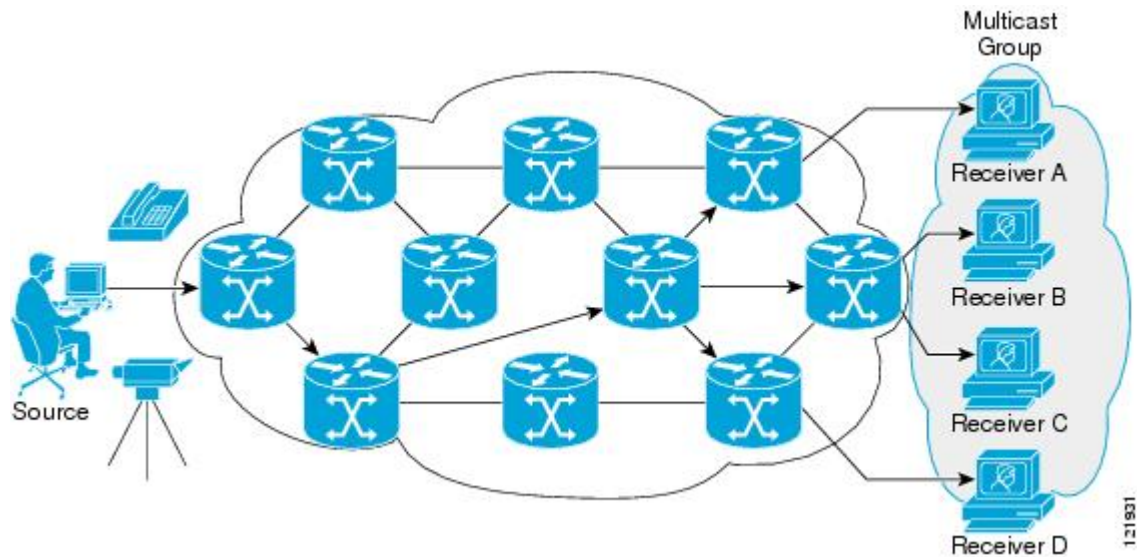

IP Multicast Boundary

As shown in the figure, address scoping defines domain boundaries so that domains with RPs that have the same IP address do not leak into each other. Scoping is performed on the subnet boundaries within large domains and on the boundaries between the domain and the Internet.

Figure 2: Address Scoping at Boundaries

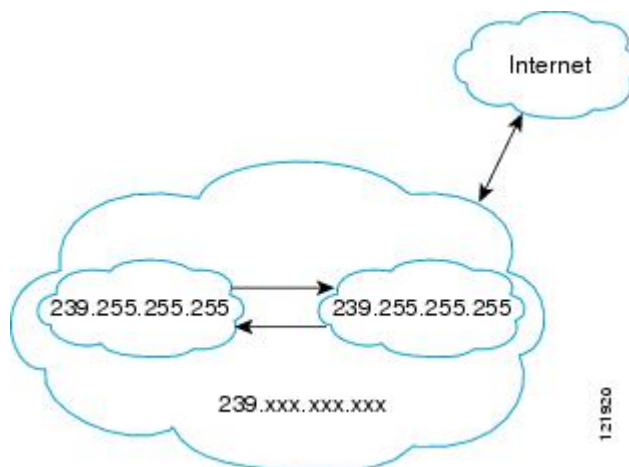

You can set up an administratively scoped boundary on an interface for multicast group addresses using the **ip multicast boundary** command with the *access-list* argument. A standard access list defines the range of addresses affected. When a boundary is set up, no multicast data packets are allowed to flow across the boundary from either direction. The boundary allows the same multicast group address to be reused in different administrative domains.

The Internet Assigned Numbers Authority (IANA) has designated the multicast address range 239.0.0.0 to 239.255.255.255 as the administratively scoped addresses. This range of addresses can be reused in domains administered by different organizations. They would be considered local, not globally unique.

You can configure the **filter-autorp** keyword to examine and filter Auto-RP discovery and announcement messages at the administratively scoped boundary. Any Auto-RP group range announcements from the Auto-RP packets that are denied by the boundary access control list (ACL) are removed. An Auto-RP group range announcement is permitted and passed by the boundary only if all addresses in the Auto-RP group range are permitted by the boundary ACL. If any address is not permitted, the entire group range is filtered and removed from the Auto-RP message before the Auto-RP message is forwarded.

IP Multicast Group Addressing

A multicast group is identified by its multicast group address. Multicast packets are delivered to that multicast group address. Unlike unicast addresses that uniquely identify a single host, multicast IP addresses do not identify a particular host. To receive the data sent to a multicast address, a host must join the group that address identifies. The data is sent to the multicast address and received by all the hosts that have joined the group indicating that they wish to receive traffic sent to that group. The multicast group address is assigned to a group at the source. Network administrators who assign multicast group addresses must make sure the addresses conform to the multicast address range assignments reserved by the Internet Assigned Numbers Authority (IANA).

IP Class D Addresses

IP multicast addresses have been assigned to the IPv4 Class D address space by IANA. The high-order four bits of a Class D address are 1110. Therefore, host group addresses can be in the range 224.0.0.0 to 239.255.255.255. A multicast address is chosen at the source (sender) for the receivers in a multicast group.



Note

The Class D address range is used only for the group address or destination address of IP multicast traffic. The source address for multicast datagrams is always the unicast source address.

IP Multicast Address Scoping

The multicast address range is subdivided to provide predictable behavior for various address ranges and for address reuse within smaller domains. The table provides a summary of the multicast address ranges. A brief summary description of each range follows.

Table 1: Multicast Address Range Assignments

Name	Range	Description
Reserved Link-Local Addresses	224.0.0.0 to 224.0.0.255	Reserved for use by network protocols on a local network segment.
Globally Scoped Addresses	224.0.1.0 to 238.255.255.255	Reserved to send multicast data between organizations and across the Internet.

Name	Range	Description
Source Specific Multicast	232.0.0.0 to 232.255.255.255	Reserved for use with the SSM datagram delivery model where data is forwarded only to receivers that have explicitly joined the group.
GLOP Addresses	233.0.0.0 to 233.255.255.255	Reserved for statically defined addresses by organizations that already have an assigned autonomous system (AS) domain number.
Limited Scope Address	239.0.0.0 to 239.255.255.255	Reserved as administratively or limited scope addresses for use in private multicast domains.

Reserved Link-Local Addresses

The IANA has reserved the range 224.0.0.0 to 224.0.0.255 for use by network protocols on a local network segment. Packets with an address in this range are local in scope and are not forwarded by IP routers. Packets with link local destination addresses are typically sent with a time-to-live (TTL) value of 1 and are not forwarded by a router.

Within this range, reserved link-local addresses provide network protocol functions for which they are reserved. Network protocols use these addresses for automatic router discovery and to communicate important routing information. For example, Open Shortest Path First (OSPF) uses the IP addresses 224.0.0.5 and 224.0.0.6 to exchange link-state information.

IANA assigns single multicast address requests for network protocols or network applications out of the 224.0.1.xxx address range. Multicast routers forward these multicast addresses.

Globally Scoped Addresses

Addresses in the range 224.0.1.0 to 238.255.255.255 are called globally scoped addresses. These addresses are used to send multicast data between organizations across the Internet. Some of these addresses have been reserved by IANA for use by multicast applications. For example, the IP address 224.0.1.1 is reserved for Network Time Protocol (NTP).

Source Specific Multicast Addresses

Addresses in the range 232.0.0.0/8 are reserved for Source Specific Multicast (SSM) by IANA. In Cisco IOS software, you can use the `ip pim ssm` command to configure SSM for arbitrary IP multicast addresses also. SSM is an extension of Protocol Independent Multicast (PIM) that allows for an efficient data delivery mechanism in one-to-many communications. SSM is described in the [IP Multicast Delivery Modes, on page 7](#) section.

GLOP Addresses

GLOP addressing (as proposed by RFC 2770, GLOP Addressing in 233/8) proposes that the 233.0.0.0/8 range be reserved for statically defined addresses by organizations that already have an AS number reserved. This practice is called GLOP addressing. The AS number of the domain is embedded into the second and third octets of the 233.0.0.0/8 address range. For example, AS 62010 is written in hexadecimal format as F23A.

Separating the two octets F2 and 3A results in 242 and 58 in decimal format. These values result in a subnet of 233.242.58.0/24 that would be globally reserved for AS 62010 to use.

Limited Scope Addresses

The range 239.0.0.0 to 239.255.255.255 is reserved as administratively or limited scoped addresses for use in private multicast domains. These addresses are constrained to a local group or organization. Companies, universities, and other organizations can use limited scope addresses to have local multicast applications that will not be forwarded outside their domain. Routers typically are configured with filters to prevent multicast traffic in this address range from flowing outside an autonomous system (AS) or any user-defined domain. Within an AS or domain, the limited scope address range can be further subdivided so that local multicast boundaries can be defined.

**Note**

Network administrators may use multicast addresses in this range, inside a domain, without conflicting with others elsewhere in the Internet.

Layer 2 Multicast Addresses

Historically, network interface cards (NICs) on a LAN segment could receive only packets destined for their burned-in MAC address or the broadcast MAC address. In IP multicast, several hosts need to be able to receive a single data stream with a common destination MAC address. Some means had to be devised so that multiple hosts could receive the same packet and still be able to differentiate between several multicast groups. One method to accomplish this is to map IP multicast Class D addresses directly to a MAC address. Using this method, NICs can receive packets destined to many different MAC address.

Cisco Group Management Protocol (CGMP) is used on routers connected to Catalyst switches to perform tasks similar to those performed by IGMP. CGMP is necessary for those Catalyst switches that cannot distinguish between IP multicast data packets and IGMP report messages, both of which are addressed to the same group address at the MAC level.

IP Multicast Delivery Modes

IP multicast delivery modes differ only for the receiver hosts, not for the source hosts. A source host sends IP multicast packets with its own IP address as the IP source address of the packet and a group address as the IP destination address of the packet.

Source Specific Multicast

Source Specific Multicast (SSM) is a datagram delivery model that best supports one-to-many applications, also known as broadcast applications. SSM is a core network technology for the Cisco implementation of IP multicast targeted for audio and video broadcast application environments.

For the SSM delivery mode, an IP multicast receiver host must use IGMP Version 3 (IGMPv3) to subscribe to channel (S,G). By subscribing to this channel, the receiver host is indicating that it wants to receive IP multicast traffic sent by source host S to group G. The network will deliver IP multicast packets from source host S to group G to all hosts in the network that have subscribed to the channel (S, G).

SSM does not require group address allocation within the network, only within each source host. Different applications running on the same source host must use different SSM groups. Different applications running on different source hosts can arbitrarily reuse SSM group addresses without causing any excess traffic on the network.

Additional References

Related Documents

Related Topic	Document Title
IP multicast commands: complete command syntax, command mode, command history, defaults, usage guidelines and examples	<i>Cisco IOS IP Multicast Command Reference</i>
For complete syntax and usage information for the commands used in this chapter.	<i>Command Reference, Cisco Release 15.2(2)E (Industrial Ethernet 3000 Switch)</i>

MIBs

MIB	MIBs Link
--	To locate and download MIBs for selected platforms, Cisco IOS releases, and feature sets, use Cisco MIB Locator found at the following URL: http://www.cisco.com/go/mibs

RFCs

RFC	Title
RFC 1112	Host Extensions for IP Multicasting
RFC 2113	IP Router Alert Option
RFC 2362	Protocol Independent Multicast-Sparse Mode (PIM-SM): Protocol Specification
RFC 3180	GLOP Addressing in 233/8

Technical Assistance

Description	Link
<p>The Cisco Support website provides extensive online resources, including documentation and tools for troubleshooting and resolving technical issues with Cisco products and technologies.</p> <p>To receive security and technical information about your products, you can subscribe to various services, such as the Product Alert Tool (accessed from Field Notices), the Cisco Technical Services Newsletter, and Really Simple Syndication (RSS) Feeds.</p> <p>Access to most tools on the Cisco Support website requires a Cisco.com user ID and password.</p>	<p>http://www.cisco.com/cisco/web/support/index.html</p>



Configuring IGMP

- [Finding Feature Information, page 11](#)
- [Prerequisites for IGMP, page 11](#)
- [Restrictions for Configuring IGMP, page 12](#)
- [Information About IGMP, page 12](#)
- [How to Configure IGMP, page 18](#)
- [Monitoring IGMP, page 31](#)
- [Configuration Examples for IGMP, page 32](#)
- [Additional References, page 33](#)

Finding Feature Information

Your software release may not support all the features documented in this module. For the latest caveats and feature information, see [Bug Search Tool](#) and the release notes for your platform and software release. To find information about the features documented in this module, and to see a list of the releases in which each feature is supported, see the feature information table at the end of this module.

Use Cisco Feature Navigator to find information about platform support and Cisco software image support. To access Cisco Feature Navigator, go to www.cisco.com/go/cfn. An account on Cisco.com is not required.

Prerequisites for IGMP

- Before performing the tasks in this module, you should be familiar with the concepts explained in the "IP Multicast Routing Technology Overview" module.
- The tasks in this module assume that IP multicast has been enabled and that the Protocol Independent Multicast (PIM) interfaces have been configured using the tasks described in the "Configuring Basic IP Multicast Routing" module.

Related Topics

[Configuring the Switch as a Member of a Group](#) , on page 18

[IGMP Join Process](#), on page 16

[IGMP Leave Process](#), on page 17

Restrictions for Configuring IGMP

The following are the restrictions for configuring IGMP:

- The switch supports IGMP Versions 1, 2 , and 3.



Note For IGMP Version 3, only IGMP Version 3 BISS (Basic IGMPv3 Snooping Support) is supported.

- IGMP Version 3 uses new membership report messages that might not be correctly recognized by older IGMP snooping switches.
- IGMPv3 can operate with both ISM and SSM. In ISM, both exclude and include mode reports are applicable. In SSM, only include mode reports are accepted by the last-hop router. Exclude mode reports are ignored.

Related Topics

[IGMP Version 3](#), on page 14

Information About IGMP

Role of the Internet Group Management Protocol

IGMP is used to dynamically register individual hosts in a multicast group on a particular LAN. Enabling PIM on an interface also enables IGMP. IGMP provides a means to automatically control and limit the flow of multicast traffic throughout your network with the use of special multicast queriers and hosts.

- A querier is a network device, such as a router, that sends query messages to discover which network devices are members of a given multicast group.
- A host is a receiver, including routers, that sends report messages (in response to query messages) to inform the querier of a host membership. Hosts use IGMP messages to join and leave multicast groups.

Hosts identify group memberships by sending IGMP messages to their local multicast device. Under IGMP, devices listen to IGMP messages and periodically send out queries to discover which groups are active or inactive on a particular subnet.

IGMP Multicast Addresses

IP multicast traffic uses group addresses, which are Class D IP addresses. The high-order four bits of a Class D address are 1110. Therefore, host group addresses can be in the range 224.0.0.0 to 239.255.255.255.

Multicast addresses in the range 224.0.0.0 to 224.0.0.255 are reserved for use by routing protocols and other network control traffic. The address 224.0.0.0 is guaranteed not to be assigned to any group.

IGMP packets are transmitted using IP multicast group addresses as follows:

- IGMP general queries are destined to the address 224.0.0.1 (all systems on a subnet).
- IGMP group-specific queries are destined to the group IP address for which the device is querying.
- IGMP group membership reports are destined to the group IP address for which the device is reporting.
- IGMPv2 leave-group messages are destined to the address 224.0.0.2 (all devices on a subnet).
- IGMPv3 membership reports are destined to the address 224.0.0.22; all IGMPv3-capable multicast devices must listen to this address.

IGMP Versions

The switch supports IGMP version 1, IGMP version 2, and IGMP version 3. These versions are interoperable on the switch. For example, if IGMP snooping is enabled and the querier's version is IGMPv2, and the switch receives an IGMPv3 report from a host, then the switch can forward the IGMPv3 report to the multicast router.

An IGMPv3 switch can receive messages from and forward messages to a device running the Source Specific Multicast (SSM) feature.

Related Topics

[Changing the IGMP Version, on page 22](#)

[Restrictions for IGMP Snooping, on page 158](#)

IGMP Version 1

IGMP version 1 (IGMPv1) primarily uses a query-response model that enables the multicast router and multilayer switch to find which multicast groups are active (have one or more hosts interested in a multicast group) on the local subnet. IGMPv1 has other processes that enable a host to join and leave a multicast group. For more information, see RFC 1112.

IGMP Version 2

IGMPv2 extends IGMP functionality by providing such features as the IGMP leave process to reduce leave latency, group-specific queries, and an explicit maximum query response time. IGMPv2 also adds the capability for routers to elect the IGMP querier without depending on the multicast protocol to perform this task. For more information, see RFC 2236.



Note IGMP version 2 is the default version for the switch.

IGMP Version 3

The switch supports IGMP version 3.

An IGMPv3 switch supports Basic IGMPv3 Snooping Support (BISS), which includes support for the snooping features on IGMPv1 and IGMPv2 switches and for IGMPv3 membership report messages. BISS constrains the flooding of multicast traffic when your network includes IGMPv3 hosts. It constrains traffic to approximately the same set of ports as the IGMP snooping feature on IGMPv2 or IGMPv1 hosts.

An IGMPv3 switch can receive messages from and forward messages to a device running the Source Specific Multicast (SSM) feature.

Related Topics

[Restrictions for Configuring IGMP, on page 12](#)

IGMPv3 Host Signalling

In IGMPv3, hosts signal membership to last hop routers of multicast groups. Hosts can signal group membership with filtering capabilities with respect to sources. A host can either signal that it wants to receive traffic from all sources sending to a group except for some specific sources (called exclude mode), or that it wants to receive traffic only from some specific sources sending to the group (called include mode).

IGMPv3 can operate with both Internet Standard Multicast (ISM) and Source Specific Multicast (SSM). In ISM, both exclude and include mode reports are applicable. In SSM, only include mode reports are accepted by the last-hop router. Exclude mode reports are ignored.

IGMP Versions Differences

There are three versions of IGMP, as defined by Request for Comments (RFC) documents of the Internet Engineering Task Force (IETF). IGMPv2 improves over IGMPv1 by adding the ability for a host to signal desire to leave a multicast group and IGMPv3 improves over IGMPv2 mainly by adding the ability to listen to multicast originating from a set of source IP addresses only.

Table 2: IGMP Versions

IGMP Version	Description
IGMPv1	Provides the basic query-response mechanism that allows the multicast device to determine which multicast groups are active and other processes that enable hosts to join and leave a multicast group. RFC 1112 defines the IGMPv1 host extensions for IP multicasting.

IGMP Version	Description
IGMPv2	Extends IGMP, allowing such capabilities as the IGMP leave process, group-specific queries, and an explicit maximum response time field. IGMPv2 also adds the capability for devices to elect the IGMP querier without dependence on the multicast protocol to perform this task. RFC 2236 defines IGMPv2.

**Note**

By default, enabling a PIM on an interface enables IGMPv2 on that device. IGMPv2 was designed to be as backward compatible with IGMPv1 as possible. To accomplish this backward compatibility, RFC 2236 defined special interoperability rules. If your network contains legacy IGMPv1 hosts, you should be familiar with these operability rules. For more information about IGMPv1 and IGMPv2 interoperability, see RFC 2236, Internet Group Management Protocol, Version 2 .

Devices That Run IGMPv1

IGMPv1 devices send IGMP queries to the “all-hosts” multicast address of 224.0.0.1 to solicit multicast groups with active multicast receivers. The multicast receivers also can send IGMP reports to the device to notify it that they are interested in receiving a particular multicast stream. Hosts can send the report asynchronously or in response to the IGMP queries sent by the device. If more than one multicast receiver exists for the same multicast group, only one of these hosts sends an IGMP report message; the other hosts suppress their report messages.

In IGMPv1, there is no election of an IGMP querier. If more than one device on the segment exists, all the devices send periodic IGMP queries. IGMPv1 has no special mechanism by which the hosts can leave the group. If the hosts are no longer interested in receiving multicast packets for a particular group, they simply do not reply to the IGMP query packets sent from the device. The device continues sending query packets. If the device does not hear a response in three IGMP queries, the group times out and the device stops sending multicast packets on the segment for the group. If the host later wants to receive multicast packets after the timeout period, the host simply sends a new IGMP join to the device, and the device begins to forward the multicast packet again.

If there are multiple devices on a LAN, a designated router (DR) must be elected to avoid duplicating multicast traffic for connected hosts. PIM devices follow an election process to select a DR. The PIM device with the highest IP address becomes the DR.

The DR is responsible for the following tasks:

- Sending PIM register and PIM Join and Prune messages toward the rendezvous point (RP) to inform it about host group membership.
- Sending IGMP host-query messages.
- Sending host-query messages by default every 60 seconds in order to keep the IGMP overhead on hosts and networks very low.

Devices That Run IGMPv2

IGMPv2 improves the query messaging capabilities of IGMPv1.

The query and membership report messages in IGMPv2 are identical to the IGMPv1 messages with two exceptions:

- IGMPv2 query messages are broken into two categories: general queries (identical to IGMPv1 queries) and group-specific queries.
- IGMPv1 membership reports and IGMPv2 membership reports have different IGMP type codes.

IGMPv2 also enhances IGMP by providing support for the following capabilities:

- Querier election process--Provides the capability for IGMPv2 devices to elect the IGMP querier without having to rely on the multicast routing protocol to perform the process.
- Maximum Response Time field--A new field in query messages permits the IGMP querier to specify the maximum query-response time. This field permits the tuning of the query-response process to control response burstiness and to fine-tune leave latencies.
- Group-Specific Query messages--Permits the IGMP querier to perform the query operation on a specific group instead of all groups.
- Leave-Group messages--Provides hosts with a method of notifying devices on the network that they wish to leave the group.

Unlike IGMPv1, in which the DR and the IGMP querier are typically the same device, in IGMPv2 the two functions are decoupled. The DR and the IGMP querier are selected based on different criteria and may be different devices on the same subnet. The DR is the device with the highest IP address on the subnet, whereas the IGMP querier is the device with the lowest IP address.

Query messages are used to elect the IGMP querier as follows:

- 1 When IGMPv2 devices start, they each multicast a general query message to the all-systems group address of 224.0.0.1 with their interface address in the source IP address field of the message.
- 2 When an IGMPv2 device receives a general query message, the device compares the source IP address in the message with its own interface address. The device with the lowest IP address on the subnet is elected the IGMP querier.
- 3 All devices (excluding the querier) start the query timer, which is reset whenever a general query message is received from the IGMP querier. If the query timer expires, it is assumed that the IGMP querier has gone down, and the election process is performed again to elect a new IGMP querier.

By default, the timer is two times the query interval.

IGMP Join and Leave Process

IGMP Join Process

When a host wants to join a multicast group, the host sends one or more unsolicited membership reports for the multicast group it wants to join. The IGMP join process is the same for IGMPv1 and IGMPv2 hosts.

In IGMPv3, the join process for hosts proceeds as follows:

- When a hosts wants to join a group, it sends an IGMPv3 membership report to 224.0.0.22 with an empty EXCLUDE list.

- When a host wants to join a specific channel, it sends an IGMPv3 membership report to 224.0.0.22 with the address of the specific source included in the INCLUDE list.
- When a host wants to join a group excluding particular sources, it sends an IGMPv3 membership report to 224.0.0.22 excluding those sources in the EXCLUDE list.

**Note**

If some IGMPv3 hosts on a LAN wish to exclude a source and others wish to include the source, then the device will send traffic for the source on the LAN (that is, inclusion trumps exclusion in this situation).

Related Topics

[Configuring the Switch as a Member of a Group](#) , on page 18

[Prerequisites for IGMP](#) , on page 11

[Example: Configuring the Switch as a Member of a Multicast Group](#) , on page 32

IGMP Leave Process

The method that hosts use to leave a group varies depending on the version of IGMP in operation.

IGMPv1 Leave Process

There is no leave-group message in IGMPv1 to notify the devices on the subnet that a host no longer wants to receive the multicast traffic from a specific group. The host simply stops processing traffic for the multicast group and ceases responding to IGMP queries with IGMP membership reports for the group. As a result, the only way IGMPv1 devices know that there are no longer any active receivers for a particular multicast group on a subnet is when the devices stop receiving membership reports. To facilitate this process, IGMPv1 devices associate a countdown timer with an IGMP group on a subnet. When a membership report is received for the group on the subnet, the timer is reset. For IGMPv1 devices, this timeout interval is typically three times the query interval (3 minutes). This timeout interval means that the device may continue to forward multicast traffic onto the subnet for up to 3 minutes after all hosts have left the multicast group.

IGMPv2 Leave Process

IGMPv2 incorporates a leave-group message that provides the means for a host to indicate that it wishes to stop receiving multicast traffic for a specific group. When an IGMPv2 host leaves a multicast group, if it was the last host to respond to a query with a membership report for that group, it sends a leave-group message to the all-devices multicast group (224.0.0.2).

IGMPv3 Leave Process

IGMPv3 enhances the leave process by introducing the capability for a host to stop receiving traffic from a particular group, source, or channel in IGMP by including or excluding sources, groups, or channels in IGMPv3 membership reports.

Related Topics

[Configuring the Switch as a Member of a Group](#) , on page 18

[Prerequisites for IGMP](#) , on page 11

[Example: Configuring the Switch as a Member of a Multicast Group](#) , on page 32

Default IGMP Configuration

This table displays the default IGMP configuration for the switch.

Table 3: Default IGMP Configuration

Feature	Default Setting
Multilayer switch as a member of a multicast group	No group memberships are defined.
Access to multicast groups	All groups are allowed on an interface.
IGMP version	Version 2 on all interfaces.
IGMP host-query message interval	60 seconds on all interfaces.
IGMP query timeout	60 seconds on all interfaces.
IGMP maximum query response time	10 seconds on all interfaces.
Multilayer switch as a statically connected member	Disabled.

How to Configure IGMP

Configuring the Switch as a Member of a Group

You can configure the switch as a member of a multicast group and discover multicast reachability in a network. If all the multicast-capable routers and multilayer switches that you administer are members of a multicast group, pinging that group causes all of these devices to respond. The devices respond to ICMP echo-request packets addressed to a group of which they are members. Another example is the multicast trace-route tools provided in the software.



Caution

Performing this procedure might impact the CPU performance because the CPU will receive all data traffic for the group address.

This procedure is optional.

SUMMARY STEPS

1. **enable**
2. **configure terminal**
3. **interface** *interface-id*
4. **ip igmp join-group** *group-address*
5. **end**
6. **show ip igmp interface** [*interface-id*]
7. **copy running-config startup-config**

DETAILED STEPS

	Command or Action	Purpose
Step 1	enable Example: Switch> enable	Enables privileged EXEC mode. Enter your password if prompted.
Step 2	configure terminal Example: Switch# configure terminal	Enters the global configuration mode.
Step 3	interface <i>interface-id</i> Example: Switch(config)# interface gigabitethernet 1/0/1	<p>Specifies the Layer 3 interface on which you want to enable multicast routing, and enters interface configuration mode.</p> <p>The specified interface must be one of the following:</p> <ul style="list-style-type: none"> • A routed port—A physical port that has been configured as a Layer 3 port by entering the no switchport interface configuration command. You will also need to enable IP PIM sparse-dense-mode on the interface, and join the interface as a statically connected member to an IGMP static group. For a configuration example, see Example: Interface Configuration as a Routed Port. • An SVI—A VLAN interface created by using the interface vlan <i>vlan-id</i> global configuration command. You will also need to enable IP PIM sparse-dense-mode on the VLAN, join the VLAN as a statically connected member to an IGMP static group, and then enable IGMP snooping on the VLAN, the IGMP static group, and physical interface. For a configuration example, see Example: Interface Configuration as an SVI. <p>These interfaces must have IP addresses assigned to them.</p>
Step 4	ip igmp join-group <i>group-address</i>	Configures the switch to join a multicast group.

	Command or Action	Purpose
	<p>Example:</p> <pre>Switch(config-if)# ip igmp join-group 225.2.2.2</pre>	<p>By default, no group memberships are defined.</p> <p>For <i>group-address</i>, specify the multicast IP address in dotted decimal notation.</p> <p>Note To cancel membership in a group, use the no ip igmp join-group <i>group-address</i> interface configuration command.</p>
Step 5	<p>end</p> <p>Example:</p> <pre>Switch(config)# end</pre>	Returns to privileged EXEC mode.
Step 6	<p>show ip igmp interface [<i>interface-id</i>]</p> <p>Example:</p> <pre>Switch# show ip igmp interface</pre>	Verifies your entries.
Step 7	<p>copy running-config startup-config</p> <p>Example:</p> <pre>Switch# copy running-config startup-config</pre>	(Optional) Saves your entries in the configuration file.

Related Topics

[IGMP Join Process, on page 16](#)

[IGMP Leave Process, on page 17](#)

[Prerequisites for IGMP, on page 11](#)

[Example: Configuring the Switch as a Member of a Multicast Group, on page 32](#)

Controlling Access to IP Multicast Group

The switch sends IGMP host-query messages to find which multicast groups have members on attached local networks. The switch then forwards to these group members all packets addressed to the multicast group. You can place a filter on each interface to restrict the multicast groups that hosts on the subnet serviced by the interface can join.

This procedure is optional.

SUMMARY STEPS

1. **enable**
2. **configure terminal**
3. **interface** *interface-id*
4. **ip igmp access-group** *access-list-number*
5. **exit**
6. **access-list** *access-list-number* {**deny** | **permit**} *source* [*source-wildcard*]
7. **end**
8. **show ip igmp interface** [*interface-id*]

DETAILED STEPS

	Command or Action	Purpose
Step 1	enable Example: Switch> enable	Enables privileged EXEC mode. Enter your password if prompted.
Step 2	configure terminal Example: Switch# configure terminal	Enters the global configuration mode.
Step 3	interface <i>interface-id</i> Example: Switch(config)# interface GigabitEthernet 1/0/12	Specifies the interface to be configured, and enters interface configuration mode.
Step 4	ip igmp access-group <i>access-list-number</i> Example: Switch(config-if)# ip igmp access-group 10	Specifies the multicast groups that hosts on the subnet serviced by an interface can join. By default, all groups are allowed on an interface. For <i>access-list-number</i> , specify an IP standard access list number. The range is 1 to 199. Note To disable groups on an interface, use the no ip igmp access-group interface configuration command.
Step 5	exit Example: Switch(config-if)# exit	Returns to global configuration mode.

	Command or Action	Purpose
Step 6	<p>access-list <i>access-list-number</i> {deny permit} <i>source</i> [<i>source-wildcard</i>]</p> <p>Example:</p> <pre>Switch(config)# access-list 10 permit</pre>	<p>Creates a standard access list.</p> <ul style="list-style-type: none"> For <i>access-list-number</i>, specify the access list created in Step 3. The deny keyword denies access if the conditions are matched. The permit keyword permits access if the conditions are matched. For <i>source</i>, specify the multicast group that hosts on the subnet can join. (Optional) For <i>source-wildcard</i>, enter the wildcard bits in dotted decimal notation to be applied to the source. Place ones in the bit positions that you want to ignore. <p>Recall that the access list is always terminated by an implicit deny statement for everything.</p>
Step 7	<p>end</p> <p>Example:</p> <pre>Switch(config-igmp-profile)# end</pre>	Returns to privileged EXEC mode.
Step 8	<p>show ip igmp interface [<i>interface-id</i>]</p> <p>Example:</p> <pre>Switch# show ip igmp interface</pre>	Verifies your entries.

Related Topics

[Example: Controlling Access to IP Multicast Groups, on page 33](#)

Changing the IGMP Version

By default, the switch uses IGMP Version 2, which provides features such as the IGMP query timeout and the maximum query response time.

All systems on the subnet must support the same version. The switch does not automatically detect Version 1 systems and switch to Version 1. You can mix Version 1 and Version 2 hosts on the subnet because Version 2 routers or switches always work correctly with IGMPv1 hosts.

Configure the switch for Version 1 if your hosts do not support Version 2.

This procedure is optional.

SUMMARY STEPS

1. **enable**
2. **configure terminal**
3. **interface** *interface-id*
4. **ip igmp version** { 1 | 2 | 3 }
5. **end**
6. **show ip igmp interface** [*interface-id*]
7. **copy running-config startup-config**

DETAILED STEPS

	Command or Action	Purpose
Step 1	enable Example: Switch> enable	Enables privileged EXEC mode. Enter your password if prompted.
Step 2	configure terminal Example: Switch# configure terminal	Enters the global configuration mode.
Step 3	interface <i>interface-id</i> Example: Switch(config)# interface gigabitethernet 1/0/1	Specifies the interface to be configured, and enters the interface configuration mode.
Step 4	ip igmp version { 1 2 3 } Example: Switch(config-if)# ip igmp version 2	Specifies the IGMP version that the switch uses. Note If you change to Version 1, you cannot configure the ip igmp query-interval or the ip igmp query-max-response-time interface configuration commands. To return to the default setting, use the no ip igmp version interface configuration command.
Step 5	end Example: Switch(config)# end	Returns to privileged EXEC mode.

	Command or Action	Purpose
Step 6	show ip igmp interface [<i>interface-id</i>] Example: Switch# show ip igmp interface	Verifies your entries.
Step 7	copy running-config startup-config Example: Switch# copy running-config startup-config	(Optional) Saves your entries in the configuration file.

Related Topics

[IGMP Versions, on page 13](#)

Modifying the IGMP Host-Query Message Interval

The switch periodically sends IGMP host-query messages to discover which multicast groups are present on attached networks. These messages are sent to the all-hosts multicast group (224.0.0.1) with a time-to-live (TTL) of 1. The switch sends host-query messages to refresh its knowledge of memberships present on the network. If, after some number of queries, the software discovers that no local hosts are members of a multicast group, the software stops forwarding multicast packets to the local network from remote origins for that group and sends a prune message upstream toward the source.

The switch elects a PIM designated router (DR) for the LAN (subnet). The designated router is responsible for sending IGMP host-query messages to all hosts on the LAN. In sparse mode, the designated router also sends PIM register and PIM join messages toward the RP router. With IGMPv2, the DR is the router or multilayer switch with the highest IP address. With IGMPv1, the DR is elected according to the multicast routing protocol that runs on the LAN.

This procedure is optional.

SUMMARY STEPS

1. **enable**
2. **configure terminal**
3. **interface** *interface-id*
4. **ip igmp query-interval** *seconds*
5. **end**
6. **show ip igmp interface** [*interface-id*]
7. **copy running-config startup-config**

DETAILED STEPS

	Command or Action	Purpose
Step 1	<p>enable</p> <p>Example:</p> <pre>Switch> enable</pre>	Enables privileged EXEC mode. Enter your password if prompted.
Step 2	<p>configure terminal</p> <p>Example:</p> <pre>Switch# configure terminal</pre>	Enters the global configuration mode.
Step 3	<p>interface <i>interface-id</i></p> <p>Example:</p> <pre>Switch(config)# interface gigabitethernet 1/0/1</pre>	<p>Specifies the Layer 3 interface on which you want to enable multicast routing, and enters interface configuration mode.</p> <p>The specified interface must be one of the following:</p> <ul style="list-style-type: none"> • A routed port—A physical port that has been configured as a Layer 3 port by entering the no switchport interface configuration command. You will also need to enable IP PIM sparse-dense-mode on the interface, and join the interface as a statically connected member to an IGMP static group. For a configuration example, see Example: Interface Configuration as a Routed Port. • An SVI—A VLAN interface created by using the interface vlan <i>vlan-id</i> global configuration command. You will also need to enable IP PIM sparse-dense-mode on the VLAN, join the VLAN as a statically connected member to an IGMP static group, and then enable IGMP snooping on the VLAN, the IGMP static group, and physical interface. For a configuration example, see Example: Interface Configuration as an SVI. <p>These interfaces must have IP addresses assigned to them.</p>
Step 4	<p>ip igmp query-interval <i>seconds</i></p> <p>Example:</p> <pre>Switch(config-if)# ip igmp query-interval 75</pre>	<p>Configures the frequency at which the designated router sends IGMP host-query messages.</p> <p>By default, the designated router sends IGMP host-query messages every 60 seconds to keep the IGMP overhead very low on hosts and networks.</p> <p>The range is 1 to 65535.</p> <p>Note To return to the default setting, use the no ip igmp query-interval interface configuration command.</p>
Step 5	<p>end</p> <p>Example:</p> <pre>Switch(config)# end</pre>	Returns to privileged EXEC mode.

	Command or Action	Purpose
Step 6	show ip igmp interface [<i>interface-id</i>] Example: Switch# show ip igmp interface	Verifies your entries.
Step 7	copy running-config startup-config Example: Switch# copy running-config startup-config	(Optional) Saves your entries in the configuration file.

Changing the IGMP Query Timeout for IGMPv2

If you are using IGMPv2, you can specify the period of time before the switch takes over as the querier for the interface. By default, the switch waits twice the query interval period controlled by the **ip igmp query-interval** interface configuration command. After that time, if the switch has received no queries, it becomes the querier.

This procedure is optional.

SUMMARY STEPS

1. **enable**
2. **configure terminal**
3. **interface** *interface-id*
4. **ip igmp querier-timeout** *seconds*
5. **end**
6. **show ip igmp interface** [*interface-id*]
7. **copy running-config startup-config**

DETAILED STEPS

	Command or Action	Purpose
Step 1	enable Example: Switch> enable	Enables privileged EXEC mode. Enter your password if prompted.

	Command or Action	Purpose
Step 2	<p>configure terminal</p> <p>Example:</p> <pre>Switch# configure terminal</pre>	Enters the global configuration mode.
Step 3	<p>interface <i>interface-id</i></p> <p>Example:</p> <pre>Switch(config)# interface gigabitethernet 1/0/1</pre>	<p>Specifies the Layer 3 interface on which you want to enable multicast routing, and enters interface configuration mode.</p> <p>The specified interface must be one of the following:</p> <ul style="list-style-type: none"> • A routed port—A physical port that has been configured as a Layer 3 port by entering the no switchport interface configuration command. You will also need to enable IP PIM sparse-dense-mode on the interface, and join the interface as a statically connected member to an IGMP static group. For a configuration example, see Example: Interface Configuration as a Routed Port. • An SVI—A VLAN interface created by using the interface vlan <i>vlan-id</i> global configuration command. You will also need to enable IP PIM sparse-dense-mode on the VLAN, join the VLAN as a statically connected member to an IGMP static group, and then enable IGMP snooping on the VLAN, the IGMP static group, and physical interface. For a configuration example, see Example: Interface Configuration as an SVI. <p>These interfaces must have IP addresses assigned to them.</p>
Step 4	<p>ip igmp querier-timeout <i>seconds</i></p> <p>Example:</p> <pre>Switch(config-if)# ip igmp querier-timeout 120</pre>	<p>Specifies the IGMP query timeout.</p> <p>The default is 60 seconds (twice the query interval). The range is 60 to 300.</p> <p>Note To return to the default setting, use the no ip igmp querier-timeout interface configuration command.</p>
Step 5	<p>end</p> <p>Example:</p> <pre>Switch(config)# end</pre>	Returns to privileged EXEC mode.
Step 6	<p>show ip igmp interface [<i>interface-id</i>]</p> <p>Example:</p> <pre>Switch# show ip igmp interface</pre>	Verifies your entries.

	Command or Action	Purpose
Step 7	copy running-config startup-config Example: Switch# copy running-config startup-config	(Optional) Saves your entries in the configuration file.

Changing the Maximum Query Response Time for IGMPv2

If you are using IGMPv2, you can change the maximum query response time advertised in IGMP queries. The maximum query response time enables the switch to quickly detect that there are no more directly connected group members on a LAN. Decreasing the value enables the switch to prune groups faster.

This procedure is optional.

SUMMARY STEPS

1. **enable**
2. **configure terminal**
3. **interface *interface-id***
4. **ip igmp query-max-response-time *seconds***
5. **end**
6. **show ip igmp interface [*interface-id*]**
7. **copy running-config startup-config**

DETAILED STEPS

	Command or Action	Purpose
Step 1	enable Example: Switch> enable	Enables privileged EXEC mode. Enter your password if prompted.
Step 2	configure terminal Example: Switch# configure terminal	Enters the global configuration mode.

	Command or Action	Purpose
Step 3	<p>interface <i>interface-id</i></p> <p>Example:</p> <pre>Switch(config)# interface gigabitethernet 1/0/1</pre>	<p>Specifies the Layer 3 interface on which you want to enable multicast routing, and enters interface configuration mode.</p> <p>The specified interface must be one of the following:</p> <ul style="list-style-type: none"> • A routed port—A physical port that has been configured as a Layer 3 port by entering the no switchport interface configuration command. You will also need to enable IP PIM sparse-dense-mode on the interface, and join the interface as a statically connected member to an IGMP static group. For a configuration example, see Example: Interface Configuration as a Routed Port. • An SVI—A VLAN interface created by using the interface vlan <i>vlan-id</i> global configuration command. You will also need to enable IP PIM sparse-dense-mode on the VLAN, join the VLAN as a statically connected member to an IGMP static group, and then enable IGMP snooping on the VLAN, the IGMP static group, and physical interface. For a configuration example, see Example: Interface Configuration as an SVI. <p>These interfaces must have IP addresses assigned to them.</p>
Step 4	<p>ip igmp query-max-response-time <i>seconds</i></p> <p>Example:</p> <pre>Switch(config-if)# ip igmp query-max-response-time 15</pre>	<p>Changes the maximum query response time advertised in IGMP queries. The default is 10 seconds. The range is 1 to 25.</p> <p>Note To return to the default setting, use the no ip igmp query-max-response-time interface configuration command.</p>
Step 5	<p>end</p> <p>Example:</p> <pre>Switch(config)# end</pre>	<p>Returns to privileged EXEC mode.</p>
Step 6	<p>show ip igmp interface [<i>interface-id</i>]</p> <p>Example:</p> <pre>Switch# show ip igmp interface</pre>	<p>Verifies your entries.</p>
Step 7	<p>copy running-config startup-config</p> <p>Example:</p> <pre>Switch# copy running-config startup-config</pre>	<p>(Optional) Saves your entries in the configuration file.</p>

Configuring the Switch as a Statically Connected Member

At various times, either there is not a group member on a network segment or a host that cannot report its group membership by using IGMP. However, you may want multicast traffic to be sent to that network segment. The following commands are used to pull multicast traffic down to a network segment:

- **ip igmp join-group**—The switch accepts the multicast packets in addition to forwarding them. Accepting the multicast packets prevents the switch from fast switching.
- **ip igmp static-group**—The switch does not accept the packets itself, but only forwards them. This method enables fast switching. The outgoing interface appears in the IGMP cache, but the switch itself is not a member, as evidenced by lack of an L (local) flag in the multicast route entry.

This procedure is optional.

SUMMARY STEPS

1. **enable**
2. **configure terminal**
3. **interface** *interface-id*
4. **ip igmp static-group** *group-address*
5. **end**
6. **show ip igmp interface** [*interface-id*]
7. **copy running-config startup-config**

DETAILED STEPS

	Command or Action	Purpose
Step 1	enable Example: Switch> enable	Enables privileged EXEC mode. Enter your password if prompted.
Step 2	configure terminal Example: Switch# configure terminal	Enters the global configuration mode.
Step 3	interface <i>interface-id</i> Example: Switch(config)# interface gigabitethernet 1/0/1	Specifies the Layer 3 interface on which you want to enable multicast routing, and enters interface configuration mode. The specified interface must be one of the following: <ul style="list-style-type: none"> • A routed port—A physical port that has been configured as a Layer 3 port by entering the no switchport interface configuration command. You will also need to enable IP PIM sparse-dense-mode on the interface, and join the interface as a statically connected

	Command or Action	Purpose
		<p>member to an IGMP static group. For a configuration example, see Example: Interface Configuration as a Routed Port.</p> <ul style="list-style-type: none"> An SVI—A VLAN interface created by using the interface vlan <i>vlan-id</i> global configuration command. You will also need to enable IP PIM sparse-dense-mode on the VLAN, join the VLAN as a statically connected member to an IGMP static group, and then enable IGMP snooping on the VLAN, the IGMP static group, and physical interface. For a configuration example, see Example: Interface Configuration as an SVI. <p>These interfaces must have IP addresses assigned to them.</p>
Step 4	<p>ip igmp static-group <i>group-address</i></p> <p>Example:</p> <pre>Switch(config-if)# ip igmp static-group 239.100.100.101</pre>	<p>Configures the switch as a statically connected member of a group.</p> <p>By default, this feature is disabled.</p>
Step 5	<p>end</p> <p>Example:</p> <pre>Switch(config)# end</pre>	<p>Returns to privileged EXEC mode.</p>
Step 6	<p>show ip igmp interface [<i>interface-id</i>]</p> <p>Example:</p> <pre>Switch# show ip igmp interface gigabitethernet 1/0/1</pre>	<p>Verifies your entries.</p>
Step 7	<p>copy running-config startup-config</p> <p>Example:</p> <pre>Switch# copy running-config startup-config</pre>	<p>(Optional) Saves your entries in the configuration file.</p>

Monitoring IGMP

You can display specific statistics, such as the contents of IP routing tables, caches, and databases.



Note This release does not support per-route statistics.

You can display information to learn resource usage and solve network problems. You can also display information about node reachability and discover the routing path that packets of your device are taking through the network.

You can use any of the privileged EXEC commands in the following table to display various routing statistics.

Table 4: Commands for Displaying System and Network Statistics

Command	Purpose
<code>ping [group-name group-address]</code>	Sends an ICMP Echo Request to a multicast group address.
<code>show ip igmp groups [type-number detail]</code>	Displays the multicast groups that are directly connected to the switch and that were learned through IGMP.
<code>show ip igmp interface [type number]</code>	Displays multicast-related information about an interface.
<code>show ip igmp profile [profile_number]</code>	Displays IGMP profile information.
<code>show ip igmp ssm-mapping [hostname/IP address]</code>	Displays IGMP SSM mapping information.
<code>show ip igmp static-group {class-map [interface [type]]}</code>	Displays static group information.
<code>show ip igmp vrf</code>	Displays the selected VPN routing/forwarding instance by name.

Configuration Examples for IGMP

Example: Configuring the Switch as a Member of a Multicast Group

This example shows how to enable the switch to join multicast group 255.2.2.2:

```
Switch(config)# interface gigabitethernet1/0/1
Switch(config-if)# ip igmp join-group 255.2.2.2
Switch(config-if)#
```

Related Topics

[Configuring the Switch as a Member of a Group](#), on page 18

[IGMP Join Process](#), on page 16

[IGMP Leave Process](#), on page 17

Example: Controlling Access to IP Multicast Groups

This example shows how to configure hosts attached to a port as able to join only group 255.2.2.2:

```
Switch(config)# access-list 1 255.2.2.2 0.0.0.0
Switch(config-if)# interface gigabitethernet1/0/1
Switch(config-if)# ip igmp access-group 1
```

Related Topics

[Controlling Access to IP Multicast Group](#), on page 20

Additional References

Related Documents

Related Topic	Document Title
For complete syntax and usage information for the commands used in this chapter.	<i>Command Reference, Cisco Release 15.2(2)E (Industrial Ethernet 3000 Switch)</i>
Cisco IOS commands	Cisco IOS Master Commands List, All Releases
Cisco IOS IP SLAs commands	Cisco IOS IP Multicast Command Reference

Error Message Decoder

Description	Link
To help you research and resolve system error messages in this release, use the Error Message Decoder tool.	https://www.cisco.com/cgi-bin/Support/Errordecoder/index.cgi

Standards and RFCs

Standard/RFC	Title
RFC 1112	Host Extensions for IP Multicasting
RFC 2236	Internet Group Management Protocol, Version 2
RFC 3376	<i>Internet Group Management Protocol, Version 3</i>

MIBs

MIB	MIBs Link
All supported MIBs for this release.	To locate and download MIBs for selected platforms, Cisco IOS releases, and feature sets, use Cisco MIB Locator found at the following URL: http://www.cisco.com/go/mibs

Technical Assistance

Description	Link
<p>The Cisco Support website provides extensive online resources, including documentation and tools for troubleshooting and resolving technical issues with Cisco products and technologies.</p> <p>To receive security and technical information about your products, you can subscribe to various services, such as the Product Alert Tool (accessed from Field Notices), the Cisco Technical Services Newsletter, and Really Simple Syndication (RSS) Feeds.</p> <p>Access to most tools on the Cisco Support website requires a Cisco.com user ID and password.</p>	http://www.cisco.com/support



Configuring CGMP

- [Finding Feature Information](#), page 35
- [Prerequisites for Configuring CGMP](#), page 35
- [Restrictions for CGMP](#), page 35
- [Information About CGMP](#), page 36
- [Enabling CGMP Server Support](#), page 36
- [Monitoring CGMP](#), page 38
- [Additional References](#), page 39

Finding Feature Information

Your software release may not support all the features documented in this module. For the latest caveats and feature information, see [Bug Search Tool](#) and the release notes for your platform and software release. To find information about the features documented in this module, and to see a list of the releases in which each feature is supported, see the feature information table at the end of this module.

Use Cisco Feature Navigator to find information about platform support and Cisco software image support. To access Cisco Feature Navigator, go to www.cisco.com/go/cfn. An account on Cisco.com is not required.

Prerequisites for Configuring CGMP

The following are the prerequisites for configuring CGMP:

- When multiple Cisco CGMP-capable devices are connected to a switched network and the **ip cgmp proxy** command is needed, we recommend that all devices be configured with the same CGMP option and have precedence for becoming the IGMP querier over non-Cisco routers.

Restrictions for CGMP

The following are the restrictions for CGMP:

- CGMP is mutually exclusive with HSRPv1. You cannot enable CGMP leaving processing and HSRPv1 at the same time. However, you can enable CGMP and HSRPv2 at the same time.

Information About CGMP

Cisco Group Management Protocol or CGMP-server support is provided on the switch; no client-side functionality is provided. The switch serves as a CGMP server for devices that do not support IGMP snooping but have CGMP-client functionality.

CGMP is a protocol used on Cisco routers and multilayer switches connected to Layer 2 Catalyst switches to perform tasks similar to those performed by IGMP. CGMP permits Layer 2 group membership information to be communicated from the CGMP server to the switch. The switch can then learn on which interfaces multicast members reside instead of flooding multicast traffic to all switch interfaces. (IGMP snooping is another method to constrain the flooding of multicast packets.)

CGMP is necessary because the Layer 2 switch cannot distinguish between IP multicast data packets and IGMP report messages, which are both at the MAC level and are addressed to the same group address.

Enabling CGMP Server Support

When multiple Cisco CGMP-capable devices are connected to a switched network and you configure the **ip cgmp proxy** command, we recommend that all devices be configured with the same CGMP option and have precedence for becoming the IGMP querier over non-Cisco routers. Perform these steps to enable the CGMP server on the switch interface:

This procedure is optional.

SUMMARY STEPS

1. **enable**
2. **configure terminal**
3. **interface** *interface-id*
4. **ip cgmp** [**proxy** | **router-only**]
5. **end**
6. **show running-config**
7. **copy running-config startup-config**

DETAILED STEPS

	Command or Action	Purpose
Step 1	enable Example: Switch> enable	Enables privileged EXEC mode. <ul style="list-style-type: none"> • Enter your password if prompted.

	Command or Action	Purpose
Step 2	<p>configure terminal</p> <p>Example:</p> <pre>Switch# configure terminal</pre>	Enters global configuration mode.
Step 3	<p>interface <i>interface-id</i></p> <p>Example:</p> <pre>Switch(config)# interface gigabitethernet 1/0/1</pre>	Specifies the interface that is connected to the Layer 2 Catalyst switch, and enters interface configuration mode.
Step 4	<p>ip cgmp [proxy router-only]</p> <p>Example:</p> <pre>Switch(config-if)# ip cgmp proxy</pre>	<p>Enables CGMP on the interface.</p> <p>By default, CGMP is disabled on all interfaces.</p> <p>Enabling CGMP triggers a CGMP join message. Enable CGMP only on Layer 3 interfaces connected to Layer 2 Catalyst switches.</p> <p>(Optional) When you enter the proxy keyword, the CGMP proxy function is enabled. The proxy router advertises the existence of non-CGMP-capable routers by sending a CGMP join message with the non-CGMP-capable router MAC address and a group address of 0000.0000.0000.</p> <p>Note To perform CGMP proxy, the switch must be the IGMP querier. If you configure the ip cgmp proxy command, you must manipulate the IP addresses so that the switch is the IGMP querier, which might be the highest or lowest IP address, depending on which version of IGMP is running on the network. An IGMP Version 2 querier is selected based on the lowest IP address on the interface. An IGMP Version 1 querier is selected based on the multicast routing protocol used on the interface.</p> <p>Note To disable CGMP on the interface, use the no ip cgmp interface configuration command.</p>
Step 5	<p>end</p> <p>Example:</p> <pre>Switch(config-if)# end</pre>	Returns to privileged EXEC mode.
Step 6	<p>show running-config</p> <p>Example:</p> <pre>Switch# show running-config</pre>	Verifies your entries.

	Command or Action	Purpose
Step 7	copy running-config startup-config Example: Switch# copy running-config startup-config	(Optional) Saves your entries in the configuration file.

What to Do Next

Verify the Layer 2 Catalyst switch CGMP-client configuration. For more information, see the documentation that shipped with the product

Monitoring CGMP

You can display specific statistics, such as the contents of IP routing tables, caches, and databases.



Note

This release does not support per-route statistics.

You can display information to learn resource usage and solve network problems. You can also display information about node reachability and discover the routing path that packets of your device are taking through the network.

You can use any of the privileged EXEC commands in the following table to display various routing statistics.

Table 5: Commands for Displaying System and Network Statistics

Command	Purpose
ping [<i>group-name</i> <i>group-address</i>]	Sends an ICMP Echo Request to a multicast group address.
show ip igmp groups [<i>group-name</i> <i>group-address</i> <i>type number</i>]	Displays the multicast groups that are directly connected to the switch and that were learned through IGMP.
show ip igmp interface [<i>type number</i>]	Displays multicast-related information about an interface.
show ip mcache [<i>group</i> [<i>source</i>]]	Displays the contents of the IP fast-switching cache.
show ip mpacket [<i>source-address</i> <i>name</i>] [<i>group-address</i> <i>name</i>] [detail]	Displays the contents of the circular cache-header buffer.
show ip mroute [<i>group-name</i> <i>group-address</i>] [<i>source</i>] [summary] [count] [active kbps]	Displays the contents of the IP multicast routing table.

Command	Purpose
show ip pim interface [<i>type number</i>] [<i>count</i>] [<i>detail</i>]	Displays information about interfaces configured for PIM. This command is available in all software images.
show ip pim neighbor [<i>type number</i>]	Lists the PIM neighbors discovered by the switch. This command is available in all software images.
show ip pim rp [<i>group-name</i> <i>group-address</i>]	Displays the RP routers associated with a sparse-mode multicast group. This command is available in all software images.
show ip rpf { <i>source-address</i> <i>name</i> }	Displays how the switch is doing Reverse-Path Forwarding (that is, from the unicast routing table, DVMRP routing table, or static mroutes).
show ip sap [<i>group</i> <i>session-name</i> detail]	Displays the Session Announcement Protocol (SAP) Version 2 cache.

Additional References

Related Documents

Related Topic	Document Title
For complete syntax and usage information for the commands used in this chapter.	<i>Command Reference, Cisco Release 15.2(2)E (Industrial Ethernet 3000 Switch)</i>
Cisco IOS commands	Cisco IOS Master Commands List, All Releases
Cisco IOS IP SLAs commands	Cisco IOS IP Multicast Command Reference

Standards and RFCs

Standard/RFC	Title
—	—

MIBs

MIB	MIBs Link
All supported MIBs for this release.	To locate and download MIBs for selected platforms, Cisco IOS releases, and feature sets, use Cisco MIB Locator found at the following URL: http://www.cisco.com/go/mibs

Technical Assistance

Description	Link
<p>The Cisco Support website provides extensive online resources, including documentation and tools for troubleshooting and resolving technical issues with Cisco products and technologies.</p> <p>To receive security and technical information about your products, you can subscribe to various services, such as the Product Alert Tool (accessed from Field Notices), the Cisco Technical Services Newsletter, and Really Simple Syndication (RSS) Feeds.</p> <p>Access to most tools on the Cisco Support website requires a Cisco.com user ID and password.</p>	http://www.cisco.com/support



Configuring PIM

- [Finding Feature Information](#), page 41
- [Prerequisites for PIM](#), page 41
- [Restrictions for PIM](#), page 42
- [Information About PIM](#), page 44
- [How to Configure PIM](#), page 58
- [Monitoring and Troubleshooting PIM](#), page 93
- [Configuration Examples for PIM](#), page 94
- [Additional References](#), page 98

Finding Feature Information

Your software release may not support all the features documented in this module. For the latest caveats and feature information, see [Bug Search Tool](#) and the release notes for your platform and software release. To find information about the features documented in this module, and to see a list of the releases in which each feature is supported, see the feature information table at the end of this module.

Use Cisco Feature Navigator to find information about platform support and Cisco software image support. To access Cisco Feature Navigator, go to www.cisco.com/go/cfn. An account on Cisco.com is not required.

Prerequisites for PIM

- Before you begin the PIM configuration process, decide which PIM mode to use. This is based on the applications you intend to support on your network. Use the following guidelines:
 - In general, if the application is one-to-many or many-to-many in nature, then PIM-SM can be used successfully.
 - For optimal one-to-many application performance, SSM is appropriate but requires IGMP version 3 support.

- Before you configure PIM stub routing, check that you have met these conditions:
 - You must have IP multicast routing configured on both the stub router and the central router. You must also have PIM mode (dense-mode, sparse-mode, or sparse-dense-mode) configured on the uplink interface of the stub router.
 - You must also configure Enhanced Interior Gateway Routing Protocol (EIGRP) stub routing on the switch.
 - The PIM stub router does not route the transit traffic between the distribution routers. Unicast (EIGRP) stub routing enforces this behavior. You must configure unicast stub routing to assist the PIM stub router behavior.

Restrictions for PIM

PIMv1 and PIMv2 Interoperability

To avoid misconfiguring multicast routing on your switch, review the information in this section.

The Cisco PIMv2 implementation provides interoperability and transition between Version 1 and Version 2, although there might be some minor problems.

You can upgrade to PIMv2 incrementally. PIM Versions 1 and 2 can be configured on different routers and multilayer switches within one network. Internally, all routers and multilayer switches on a shared media network must run the same PIM version. Therefore, if a PIMv2 device detects a PIMv1 device, the Version 2 device downgrades itself to Version 1 until all Version 1 devices have been shut down or upgraded.

PIMv2 uses the BSR to discover and announce RP-set information for each group prefix to all the routers and multilayer switches in a PIM domain. PIMv1, together with the Auto-RP feature, can perform the same tasks as the PIMv2 BSR. However, Auto-RP is a standalone protocol, separate from PIMv1, and is a proprietary Cisco protocol. PIMv2 is a standards track protocol in the IETF.



Note

We recommend that you use PIMv2. The BSR function interoperates with Auto-RP on Cisco routers and multilayer switches.

When PIMv2 devices interoperate with PIMv1 devices, Auto-RP should have already been deployed. A PIMv2 BSR that is also an Auto-RP mapping agent automatically advertises the RP elected by Auto-RP. That is, Auto-RP sets its single RP on every router or multilayer switch in the group. Not all routers and switches in the domain use the PIMv2 hash function to select multiple RPs.

Dense-mode groups in a mixed PIMv1 and PIMv2 region need no special configuration; they automatically interoperate.

Sparse-mode groups in a mixed PIMv1 and PIMv2 region are possible because the Auto-RP feature in PIMv1 interoperates with the PIMv2 RP feature. Although all PIMv2 devices can also use PIMv1, we recommend that the RPs be upgraded to PIMv2. To ease the transition to PIMv2, we recommend:

- Using Auto-RP throughout the region.
- Configuring sparse-dense mode throughout the region.

If Auto-RP is not already configured in the PIMv1 regions, configure Auto-RP.

Related Topics

[PIM Versions](#), on page 47

Restrictions for Configuring PIM Stub Routing

- The IP services image contains complete multicast routing.
- Only directly connected multicast (IGMP) receivers and sources are allowed in the Layer 2 access domains. The PIM protocol is not supported in access domains.
- In a network using PIM stub routing, the only allowable route for IP traffic to the user is through a switch that is configured with PIM stub routing.
- The redundant PIM stub router topology is not supported. Only the nonredundant access router topology is supported by the PIM stub feature.

Related Topics

[Enabling PIM Stub Routing](#), on page 58

[PIM Stub Routing](#), on page 47

Restrictions for Configuring Auto-RP and BSR

Take into consideration your network configuration, and the following restrictions when configuring Auto-RP and BSR:

Restrictions for Configuring Auto-RP

The following are restrictions for configuring Auto-RP (if used in your network configuration):

- If you configure PIM in sparse mode or sparse-dense mode and do not configure Auto-RP, you must manually configure an RP.
- If routed interfaces are configured in sparse mode, Auto-RP can still be used if all devices are configured with a manual RP address for the Auto-RP groups.
- If routed interfaces are configured in sparse mode and you enter the **ip pim autorp listener** global configuration command, Auto-RP can still be used even if all devices are not configured with a manual RP address for the Auto-RP groups.

Restrictions for Configuring BSR

The following are the restrictions for configuring BSR (if used in your network configuration):

- Configure the candidate BSRs as the RP-mapping agents for Auto-RP.
- For group prefixes advertised through Auto-RP, the PIMv2 BSR mechanism should not advertise a subrange of these group prefixes served by a different set of RPs. In a mixed PIMv1 and PIMv2 domain, have backup RPs serve the same group prefixes. This prevents the PIMv2 DRs from selecting a different RP from those PIMv1 DRs, due to the longest match lookup in the RP-mapping database.

Restrictions and Guidelines for Configuring Auto-RP and BSR

The following are restrictions for configuring Auto-RP and BSR (if used in your network configuration):

- If your network is all Cisco routers and multilayer switches, you can use either Auto-RP or BSR.
- If you have non-Cisco routers in your network, you must use BSR.
- If you have Cisco PIMv1 and PIMv2 routers and multilayer switches and non-Cisco routers, you must use both Auto-RP and BSR. If your network includes routers from other vendors, configure the Auto-RP mapping agent and the BSR on a Cisco PIMv2 device. Ensure that no PIMv1 device is located in the path a between the BSR and a non-Cisco PIMv2 device.



Note There are two approaches to using PIMv2. You can use Version 2 exclusively in your network or migrate to Version 2 by employing a mixed PIM version environment.

- Because bootstrap messages are sent hop-by-hop, a PIMv1 device prevents these messages from reaching all routers and multilayer switches in your network. Therefore, if your network has a PIMv1 device in it and only Cisco routers and multilayer switches, it is best to use Auto-RP.
- If you have a network that includes non-Cisco routers, configure the Auto-RP mapping agent and the BSR on a Cisco PIMv2 router or multilayer switch. Ensure that no PIMv1 device is on the path between the BSR and a non-Cisco PIMv2 router.
- If you have non-Cisco PIMv2 routers that need to interoperate with Cisco PIMv1 routers and multilayer switches, both Auto-RP and a BSR are required. We recommend that a Cisco PIMv2 device be both the Auto-RP mapping agent and the BSR.

Related Topics

[Setting Up Auto-RP in a New Internetwork](#) , on page 62

[Auto-RP](#) , on page 49

[Configuring Candidate BSRs](#) , on page 78

[Bootstrap Router](#) , on page 50

Information About PIM

Protocol Independent Multicast

The Protocol Independent Multicast (PIM) protocol maintains the current IP multicast service mode of receiver-initiated membership. PIM is not dependent on a specific unicast routing protocol; it is IP routing protocol independent and can leverage whichever unicast routing protocols are used to populate the unicast routing table, including Enhanced Interior Gateway Routing Protocol (EIGRP), Open Shortest Path First (OSPF), Border Gateway Protocol (BGP), and static routes. PIM uses unicast routing information to perform the multicast forwarding function.

Although PIM is called a multicast routing protocol, it actually uses the unicast routing table to perform the reverse path forwarding (RPF) check function instead of building up a completely independent multicast routing table. Unlike other routing protocols, PIM does not send and receive routing updates between routers.

PIM is defined in RFC 4601, Protocol Independent Multicast - Sparse Mode (PIM-SM)

PIM can operate in dense mode or sparse mode. The router can also handle both sparse groups and dense groups at the same time (sparse-dense mode). The mode determines how the router populates its multicast routing table and how the router forwards multicast packets it receives from its directly connected LANs.

For information about PIM forwarding (interface) modes, see the following sections:

PIM Dense Mode

PIM dense mode (PIM-DM) uses a push model to flood multicast traffic to every corner of the network. This push model is a method for delivering data to the receivers without the receivers requesting the data. This method is efficient in certain deployments in which there are active receivers on every subnet in the network.

In dense mode, a router assumes that all other routers want to forward multicast packets for a group. If a router receives a multicast packet and has no directly connected members or PIM neighbors present, a prune message is sent back to the source. Subsequent multicast packets are not flooded to this router on this pruned branch. PIM builds source-based multicast distribution trees.

PIM-DM initially floods multicast traffic throughout the network. Routers that have no downstream neighbors prune back the unwanted traffic. This process repeats every 3 minutes.

Routers accumulate state information by receiving data streams through the flood and prune mechanism. These data streams contain the source and group information so that downstream routers can build up their multicast forwarding table. PIM-DM supports only source trees--that is, (S,G) entries--and cannot be used to build a shared distribution tree.



Note

Dense mode is not often used and its use is not recommended. For this reason it is not specified in the configuration tasks in related modules.

PIM Sparse Mode

PIM sparse mode (PIM-SM) uses a pull model to deliver multicast traffic. Only network segments with active receivers that have explicitly requested the data will receive the traffic.

Unlike dense mode interfaces, sparse mode interfaces are added to the multicast routing table only when periodic Join messages are received from downstream routers, or when a directly connected member is on the interface. When forwarding from a LAN, sparse mode operation occurs if an RP is known for the group. If so, the packets are encapsulated and sent toward the RP. When no RP is known, the packet is flooded in a dense mode fashion. If the multicast traffic from a specific source is sufficient, the first hop router of the receiver may send Join messages toward the source to build a source-based distribution tree.

PIM-SM distributes information about active sources by forwarding data packets on the shared tree. Because PIM-SM uses shared trees (at least, initially), it requires the use of a rendezvous point (RP). The RP must be administratively configured in the network. See the [Rendezvous Points, on page 49](#) section for more information.

In sparse mode, a router assumes that other routers do not want to forward multicast packets for a group, unless there is an explicit request for the traffic. When hosts join a multicast group, the directly connected routers send PIM Join messages toward the RP. The RP keeps track of multicast groups. Hosts that send multicast packets are registered with the RP by the first hop router of that host. The RP then sends Join messages toward the source. At this point, packets are forwarded on a shared distribution tree. If the multicast

traffic from a specific source is sufficient, the first hop router of the host may send Join messages toward the source to build a source-based distribution tree.

Sources register with the RP and then data is forwarded down the shared tree to the receivers. The edge routers learn about a particular source when they receive data packets on the shared tree from that source through the RP. The edge router then sends PIM (S,G) Join messages toward that source. Each router along the reverse path compares the unicast routing metric of the RP address to the metric of the source address. If the metric for the source address is better, it will forward a PIM (S,G) Join message toward the source. If the metric for the RP is the same or better, then the PIM (S,G) Join message will be sent in the same direction as the RP. In this case, the shared tree and the source tree would be considered congruent.

If the shared tree is not an optimal path between the source and the receiver, the routers dynamically create a source tree and stop traffic from flowing down the shared tree. This behavior is the default behavior in software. Network administrators can force traffic to stay on the shared tree by using the **ip pim spt-threshold infinity** command.

PIM-SM scales well to a network of any size, including those with WAN links. The explicit join mechanism prevents unwanted traffic from flooding the WAN links.

Related Topics

[Adding Auto-RP to an Existing Sparse-Mode Cloud](#) , on page 65

[Configuring Sparse Mode with a Single Static RP](#) , on page 68

Sparse-Dense Mode

If you configure either sparse mode or dense mode on an interface, then sparseness or denseness is applied to the interface as a whole. However, some environments might require PIM to run in a single region in sparse mode for some groups and in dense mode for other groups.

An alternative to enabling only dense mode or only sparse mode is to enable sparse-dense mode. In this case, the interface is treated as dense mode if the group is in dense mode; the interface is treated in sparse mode if the group is in sparse mode. You must have an RP if the interface is in sparse-dense mode and you want to treat the group as a sparse group.

If you configure sparse-dense mode, the idea of sparseness or denseness is applied to the groups for which the router is a member.

Another benefit of sparse-dense mode is that Auto-RP information can be distributed in a dense mode; yet, multicast groups for user groups can be used in a sparse mode manner. Therefore there is no need to configure a default RP at the leaf routers.

When an interface is treated in dense mode, it is populated in the outgoing interface list of a multicast routing table when either of the following conditions is true:

- Members or DVMRP neighbors are on the interface.
- There are PIM neighbors and the group has not been pruned.

When an interface is treated in sparse mode, it is populated in the outgoing interface list of a multicast routing table when either of the following conditions is true:

- Members or DVMRP neighbors are on the interface.
- An explicit Join message has been received by a PIM neighbor on the interface.

PIM Versions

PIMv2 includes these improvements over PIMv1:

- A single, active rendezvous point (RP) exists per multicast group, with multiple backup RPs. This single RP compares to multiple active RPs for the same group in PIMv1.
- A bootstrap router (BSR) provides a fault-tolerant, automated RP discovery and distribution function that enables routers and multilayer switches to dynamically learn the group-to-RP mappings.
- Sparse mode and dense mode are properties of a group, as opposed to an interface.



Note We strongly recommend using sparse-dense mode as opposed to either sparse mode or dense mode only.

- PIM join and prune messages have more flexible encoding for multiple address families.
- A more flexible hello packet format replaces the query packet to encode current and future capability options.
- Register messages sent to an RP specify whether they are sent by a border router or a designated router.
- PIM packets are no longer inside IGMP packets; they are standalone packets.

Related Topics

[PIMv1 and PIMv2 Interoperability](#), on page 42

[Troubleshooting PIMv1 and PIMv2 Interoperability Problems](#), on page 94

PIM Stub Routing

The PIM stub routing feature, available in all of the switch software images, reduces resource usage by moving routed traffic closer to the end user.

The PIM stub routing feature supports multicast routing between the distribution layer and the access layer. It supports two types of PIM interfaces, uplink PIM interfaces, and PIM passive interfaces. A routed interface configured with the PIM passive mode does not pass or forward PIM control traffic, it only passes and forwards IGMP traffic.

In a network using PIM stub routing, the only allowable route for IP traffic to the user is through a switch that is configured with PIM stub routing. PIM passive interfaces are connected to Layer 2 access domains, such as VLANs, or to interfaces that are connected to other Layer 2 devices. Only directly connected multicast (IGMP) receivers and sources are allowed in the Layer 2 access domains. The PIM passive interfaces do not send or process any received PIM control packets.

When using PIM stub routing, you should configure the distribution and remote routers to use IP multicast routing and configure only the switch as a PIM stub router. The switch does not route transit traffic between distribution routers. You also need to configure a routed uplink port on the switch. The switch uplink port cannot be used with SVIs. If you need PIM for an SVI uplink port, you should upgrade to the IP Services feature set.

**Note**

You must also configure EIGRP stub routing when configuring PIM stub routing on the switch

The redundant PIM stub router topology is not supported. The redundant topology exists when there is more than one PIM router forwarding multicast traffic to a single access domain. PIM messages are blocked, and the PIM asset and designated router election mechanisms are not supported on the PIM passive interfaces. Only the nonredundant access router topology is supported by the PIM stub feature. By using a nonredundant topology, the PIM passive interface assumes that it is the only interface and designated router on that access domain.

In the following figure, the Switch A routed uplink port 25 is connected to the router and PIM stub routing is enabled on the VLAN 100 interfaces and on Host 3. This configuration allows the directly connected hosts to receive traffic from multicast source 200.1.1.3.

Figure 3: PIM Stub Router Configuration

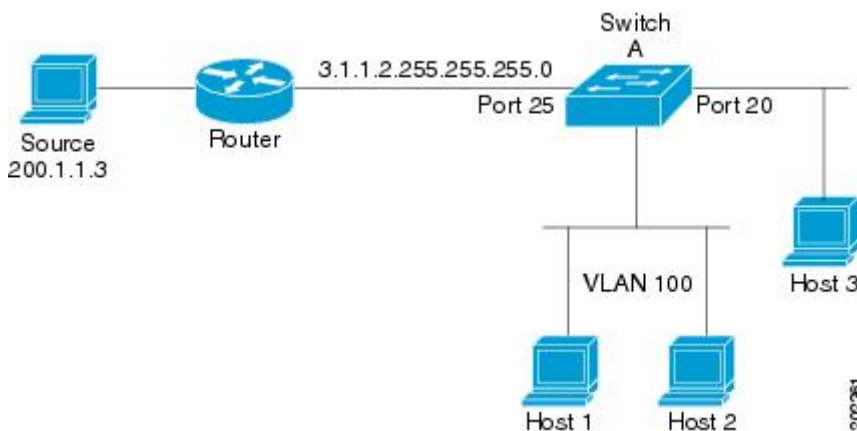
**Related Topics**

[Enabling PIM Stub Routing](#), on page 58

[Example: Enabling PIM Stub Routing](#), on page 94

[Example: Verifying PIM Stub Routing](#), on page 95

[Restrictions for Configuring PIM Stub Routing](#), on page 43

IGMP Helper

PIM stub routing moves routed traffic closer to the end user and reduces network traffic. You can also reduce traffic by configuring a stub router (switch) with the IGMP helper feature.

You can configure a stub router (switch) with the `ip igmp helper-address ip-address` interface configuration command to enable the switch to send reports to the next-hop interface. Hosts that are not directly connected to a downstream router can then join a multicast group sourced from an upstream network. The IGMP packets from a host wanting to join a multicast stream are forwarded upstream to the next-hop device when this feature is configured. When the upstream central router receives the helper IGMP reports or leaves, it adds or removes the interfaces from its outgoing interface list for that group.

Rendezvous Points

A rendezvous point (RP) is a role that a device performs when operating in Protocol Independent Multicast (PIM) Sparse Mode (SM). An RP is required only in networks running PIM SM. In the PIM-SM model, only network segments with active receivers that have explicitly requested multicast data will be forwarded the traffic. This method of delivering multicast data is in contrast to PIM Dense Mode (PIM DM). In PIM DM, multicast traffic is initially flooded to all segments of the network. Routers that have no downstream neighbors or directly connected receivers prune back the unwanted traffic.

An RP acts as the meeting place for sources and receivers of multicast data. In a PIM-SM network, sources must send their traffic to the RP. This traffic is then forwarded to receivers down a shared distribution tree. By default, when the first hop device of the receiver learns about the source, it will send a Join message directly to the source, creating a source-based distribution tree from the source to the receiver. This source tree does not include the RP unless the RP is located within the shortest path between the source and receiver.

In most cases, the placement of the RP in the network is not a complex decision. By default, the RP is needed only to start new sessions with sources and receivers. Consequently, the RP experiences little overhead from traffic flow or processing. In PIM version 2, the RP performs less processing than in PIM version 1 because sources must only periodically register with the RP to create state.

Related Topics

[Configuring a Rendezvous Point, on page 60](#)

Auto-RP

In the first version of PIM-SM, all leaf routers (routers directly connected to sources or receivers) were required to be manually configured with the IP address of the RP. This type of configuration is also known as static RP configuration. Configuring static RPs is relatively easy in a small network, but it can be laborious in a large, complex network.

Following the introduction of PIM-SM version 1, Cisco implemented a version of PIM-SM with the Auto-RP feature. Auto-RP automates the distribution of group-to-RP mappings in a PIM network. Auto-RP has the following benefits:

- Configuring the use of multiple RPs within a network to serve different groups is easy.
- Auto-RP allows load splitting among different RPs and arrangement of RPs according to the location of group participants.
- Auto-RP avoids inconsistent, manual RP configurations that can cause connectivity problems.

Multiple RPs can be used to serve different group ranges or serve as backups to each other. For Auto-RP to work, a router must be designated as an RP-mapping agent, which receives the RP-announcement messages from the RPs and arbitrates conflicts. The RP-mapping agent then sends the consistent group-to-RP mappings to all other routers. Thus, all routers automatically discover which RP to use for the groups they support.



Note

If you configure PIM in sparse mode or sparse-dense mode and do not configure Auto-RP, you must statically configure an RP.

**Note**

If router interfaces are configured in sparse mode, Auto-RP can still be used if all routers are configured with a static RP address for the Auto-RP groups.

To make Auto-RP work, a router must be designated as an RP mapping agent, which receives the RP announcement messages from the RPs and arbitrates conflicts. The RP mapping agent then sends the consistent group-to-RP mappings to all other routers by dense mode flooding. Thus, all routers automatically discover which RP to use for the groups they support. The Internet Assigned Numbers Authority (IANA) has assigned two group addresses, 224.0.1.39 and 224.0.1.40, for Auto-RP. One advantage of Auto-RP is that any change to the RP designation must be configured only on the routers that are RPs and not on the leaf routers. Another advantage of Auto-RP is that it offers the ability to scope the RP address within a domain. Scoping can be achieved by defining the time-to-live (TTL) value allowed for the Auto-RP advertisements.

Each method for configuring an RP has its own strengths, weaknesses, and level of complexity. In conventional IP multicast network scenarios, we recommend using Auto-RP to configure RPs because it is easy to configure, well-tested, and stable. The alternative ways to configure an RP are static RP, Auto-RP, and bootstrap router.

Related Topics

[Setting Up Auto-RP in a New Internetwork](#), on page 62

[Example: Configuring Auto-RP](#), on page 96

[Restrictions for Configuring Auto-RP and BSR](#), on page 43

Sparse-Dense Mode for Auto-RP

A prerequisite of Auto-RP is that all interfaces must be configured in sparse-dense mode using the **ip pim sparse-dense-mode** interface configuration command. An interface configured in sparse-dense mode is treated in either sparse mode or dense mode of operation, depending on which mode the multicast group operates. If a multicast group has a known RP, the interface is treated in sparse mode. If a group has no known RP, by default the interface is treated in dense mode and data will be flooded over this interface. (You can prevent dense-mode fallback; see the module “Configuring Basic IP Multicast.”)

To successfully implement Auto-RP and prevent any groups other than 224.0.1.39 and 224.0.1.40 from operating in dense mode, we recommend configuring a “sink RP” (also known as “RP of last resort”). A sink RP is a statically configured RP that may or may not actually exist in the network. Configuring a sink RP does not interfere with Auto-RP operation because, by default, Auto-RP messages supersede static RP configurations. We recommend configuring a sink RP for all possible multicast groups in your network, because it is possible for an unknown or unexpected source to become active. If no RP is configured to limit source registration, the group may revert to dense mode operation and be flooded with data.

Bootstrap Router

Another RP selection model called bootstrap router (BSR) was introduced after Auto-RP in PIM-SM version 2. BSR performs similarly to Auto-RP in that it uses candidate routers for the RP function and for relaying the RP information for a group. RP information is distributed through BSR messages, which are carried within PIM messages. PIM messages are link-local multicast messages that travel from PIM router to PIM router. Because of this single hop method of disseminating RP information, TTL scoping cannot be used with BSR. A BSR performs similarly as an RP, except that it does not run the risk of reverting to dense mode operation, and it does not offer the ability to scope within a domain.

Related Topics

[Configuring Candidate BSRs](#) , on page 78

[Example: Configuring Candidate BSRs](#), on page 97

[Restrictions for Configuring Auto-RP and BSR](#), on page 43

PIM Domain Border

As IP multicast becomes more widespread, the chance of one PIMv2 domain bordering another PIMv2 domain increases. Because two domains probably do not share the same set of RPs, BSR, candidate RPs, and candidate BSRs, you need to constrain PIMv2 BSR messages from flowing into or out of the domain. Allowing messages to leak across the domain borders could adversely affect the normal BSR election mechanism and elect a single BSR across all bordering domains and comingle candidate RP advertisements, resulting in the election of RPs in the wrong domain.

Related Topics

[Defining the PIM Domain Border](#) , on page 73

Multicast Forwarding

Forwarding of multicast traffic is accomplished by multicast-capable routers. These routers create distribution trees that control the path that IP multicast traffic takes through the network in order to deliver traffic to all receivers.

Multicast traffic flows from the source to the multicast group over a distribution tree that connects all of the sources to all of the receivers in the group. This tree may be shared by all sources (a shared tree) or a separate distribution tree can be built for each source (a source tree). The shared tree may be one-way or bidirectional.

Before describing the structure of source and shared trees, it is helpful to explain the notations that are used in multicast routing tables. These notations include the following:

- (S,G) = (unicast source for the multicast group G, multicast group G)
- (*,G) = (any source for the multicast group G, multicast group G)

The notation of (S,G), pronounced “S comma G,” enumerates a shortest path tree where S is the IP address of the source and G is the multicast group address.

Shared trees are (*,G) and the source trees are (S,G) and always routed at the sources.

Multicast Distribution Source Tree

The simplest form of a multicast distribution tree is a source tree. A source tree has its root at the source host and has branches forming a spanning tree through the network to the receivers. Because this tree uses the shortest path through the network, it is also referred to as a shortest path tree (SPT).

The figure shows an example of an SPT for group 224.1.1.1 rooted at the source, Host A, and connecting two receivers, Hosts B and C.

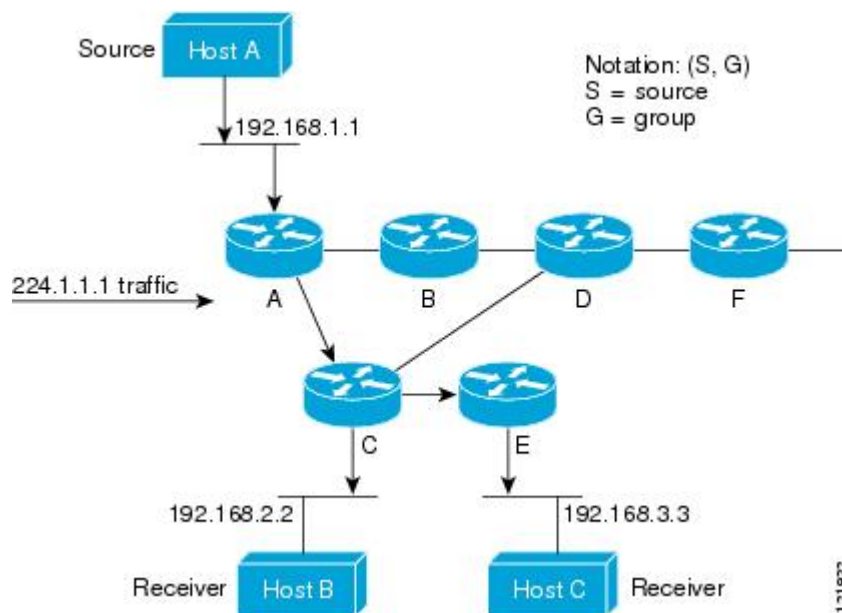

Using standard notation, the SPT for the example shown in the figure would be (192.168.1.1, 224.1.1.1).

The (S,G) notation implies that a separate SPT exists for each individual source sending to each group--which is correct.

Multicast Distribution Shared Tree

Unlike source trees that have their root at the source, shared trees use a single common root placed at some chosen point in the network. This shared root is called a rendezvous point (RP).

[Multicast Distribution Shared Tree](#) shows a shared tree for the group 224.2.2.2 with the root located at Router D. This shared tree is unidirectional. Source traffic is sent towards the RP on a source tree. The traffic is then forwarded down the shared tree from the RP to reach all of the receivers (unless the receiver is located between the source and the RP, in which case it will be serviced directly).

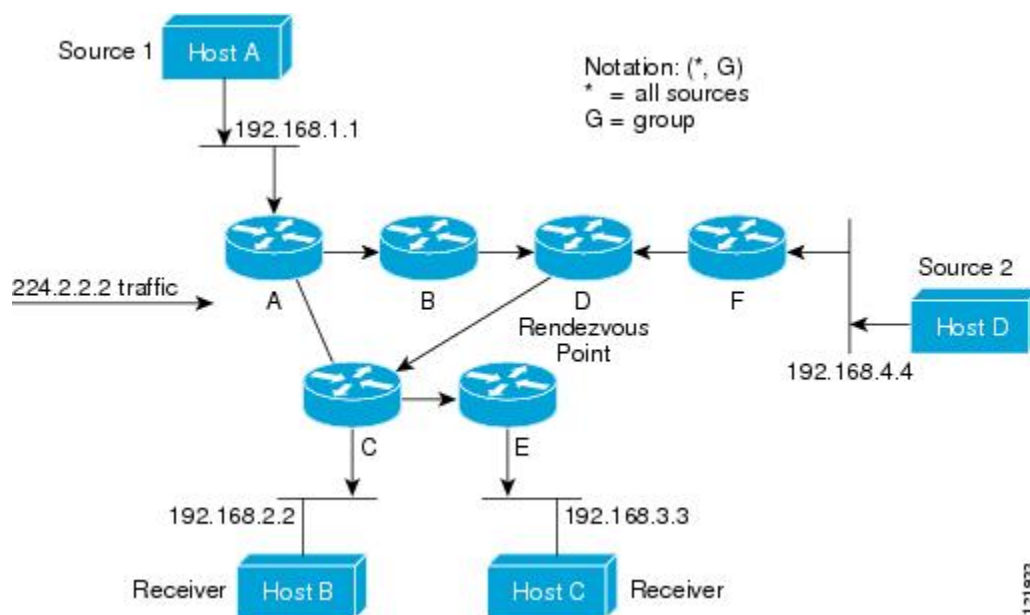

In this example, multicast traffic from the sources, Hosts A and D, travels to the root (Router D) and then down the shared tree to the two receivers, Hosts B and C. Because all sources in the multicast group use a common shared tree, a wildcard notation written as (*, G), pronounced “star comma G,” represents the tree. In this case, * means all sources, and G represents the multicast group. Therefore, the shared tree shown in [Multicast Distribution Shared Tree](#) would be written as (*, 224.2.2.2).

Both source trees and shared trees are loop-free. Messages are replicated only where the tree branches. Members of multicast groups can join or leave at any time; therefore the distribution trees must be dynamically updated. When all the active receivers on a particular branch stop requesting the traffic for a particular multicast group, the routers prune that branch from the distribution tree and stop forwarding traffic down that branch. If one receiver on that branch becomes active and requests the multicast traffic, the router will dynamically modify the distribution tree and start forwarding traffic again.

Source Tree Advantage

Source trees have the advantage of creating the optimal path between the source and the receivers. This advantage guarantees the minimum amount of network latency for forwarding multicast traffic. However, this optimization comes at a cost. The routers must maintain path information for each source. In a network that has thousands of sources and thousands of groups, this overhead can quickly become a resource issue on the routers. Memory consumption from the size of the multicast routing table is a factor that network designers must take into consideration.

Shared Tree Advantage

Shared trees have the advantage of requiring the minimum amount of state in each router. This advantage lowers the overall memory requirements for a network that only allows shared trees. The disadvantage of shared trees is that under certain circumstances the paths between the source and receivers might not be the optimal paths, which might introduce some latency in packet delivery. For example, in the figure above the shortest path between Host A (source 1) and Host B (a receiver) would be Router A and Router C. Because we are using Router D as the root for a shared tree, the traffic must traverse Routers A, B, D and then C.

Network designers must carefully consider the placement of the rendezvous point (RP) when implementing a shared tree-only environment.

In unicast routing, traffic is routed through the network along a single path from the source to the destination host. A unicast router does not consider the source address; it considers only the destination address and how to forward the traffic toward that destination. The router scans through its routing table for the destination address and then forwards a single copy of the unicast packet out the correct interface in the direction of the destination.

In multicast forwarding, the source is sending traffic to an arbitrary group of hosts that are represented by a multicast group address. The multicast router must determine which direction is the upstream direction (toward the source) and which one is the downstream direction (or directions) toward the receivers. If there are multiple downstream paths, the router replicates the packet and forwards it down the appropriate downstream paths (best unicast route metric)--which is not necessarily all paths. Forwarding multicast traffic away from the source, rather than to the receiver, is called Reverse Path Forwarding (RPF). RPF is described in the following section.

PIM Shared Tree and Source Tree

By default, members of a group receive data from senders to the group across a single data-distribution tree rooted at the RP.

The following figure shows this type of shared-distribution tree. Data from senders is delivered to the RP for distribution to group members joined to the shared tree.

Figure 4: Shared Tree and Source Tree (Shortest-Path Tree)

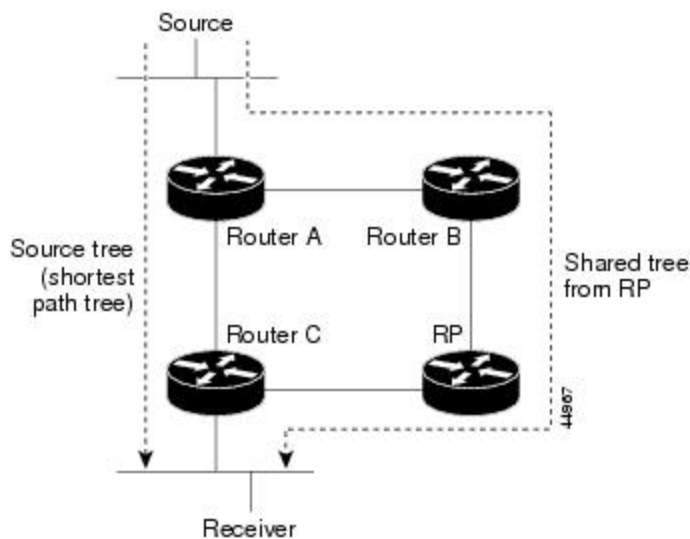

If the data rate warrants, leaf routers (routers without any downstream connections) on the shared tree can use the data distribution tree rooted at the source. This type of distribution tree is called a shortest-path tree or source tree. By default, the software switches to a source tree upon receiving the first data packet from a source.

This process describes the move from a shared tree to a source tree:

- 1 A receiver joins a group; leaf Router C sends a join message toward the RP.

- 2 The RP puts a link to Router C in its outgoing interface list.
- 3 A source sends data; Router A encapsulates the data in a register message and sends it to the RP.
- 4 The RP forwards the data down the shared tree to Router C and sends a join message toward the source. At this point, data might arrive twice at Router C, once encapsulated and once natively.
- 5 When data arrives natively (unencapsulated) at the RP, it sends a register-stop message to Router A.
- 6 By default, reception of the first data packet prompts Router C to send a join message toward the source.
- 7 When Router C receives data on (S, G), it sends a prune message for the source up the shared tree.
- 8 The RP deletes the link to Router C from the outgoing interface of (S, G). The RP triggers a prune message toward the source.

Join and prune messages are sent for sources and RPs. They are sent hop-by-hop and are processed by each PIM device along the path to the source or RP. Register and register-stop messages are not sent hop-by-hop. They are sent by the designated router that is directly connected to a source and are received by the RP for the group.

Multiple sources sending to groups use the shared tree. You can configure the PIM device to stay on the shared tree.

The change from shared to source tree happens when the first data packet arrives at the last-hop router. This change depends upon the threshold that is configured by using the **ip pim spt-threshold** global configuration command.

The shortest-path tree requires more memory than the shared tree but reduces delay. You may want to postpone its use. Instead of allowing the leaf router to immediately move to the shortest-path tree, you can specify that the traffic must first reach a threshold.

You can configure when a PIM leaf router should join the shortest-path tree for a specified group. If a source sends at a rate greater than or equal to the specified kbps rate, the multilayer switch triggers a PIM join message toward the source to construct a source tree (shortest-path tree). If the traffic rate from the source drops below the threshold value, the leaf router switches back to the shared tree and sends a prune message toward the source.

You can specify to which groups the shortest-path tree threshold applies by using a group list (a standard access list). If a value of 0 is specified or if the group list is not used, the threshold applies to all groups.

Related Topics

[Delaying the Use of PIM Shortest-Path Tree](#) , on page 81

Reverse Path Forwarding

In unicast routing, traffic is routed through the network along a single path from the source to the destination host. A unicast router does not consider the source address; it considers only the destination address and how to forward the traffic toward that destination. The router scans through its routing table for the destination network and then forwards a single copy of the unicast packet out the correct interface in the direction of the destination.

In multicast forwarding, the source is sending traffic to an arbitrary group of hosts that are represented by a multicast group address. The multicast router must determine which direction is the upstream direction (toward the source) and which one is the downstream direction (or directions) toward the receivers. If there are multiple downstream paths, the router replicates the packet and forwards it down the appropriate downstream paths (best unicast route metric)--which is not necessarily all paths. Forwarding multicast traffic away from the

source, rather than to the receiver, is called Reverse Path Forwarding (RPF). RPF is an algorithm used for forwarding multicast datagrams.

Protocol Independent Multicast (PIM) uses the unicast routing information to create a distribution tree along the reverse path from the receivers towards the source. The multicast routers then forward packets along the distribution tree from the source to the receivers. RPF is a key concept in multicast forwarding. It enables routers to correctly forward multicast traffic down the distribution tree. RPF makes use of the existing unicast routing table to determine the upstream and downstream neighbors. A router will forward a multicast packet only if it is received on the upstream interface. This RPF check helps to guarantee that the distribution tree will be loop-free.

RPF Check

When a multicast packet arrives at a router, the router performs an RPF check on the packet. If the RPF check succeeds, the packet is forwarded. Otherwise, it is dropped.

For traffic flowing down a source tree, the RPF check procedure works as follows:

- 1 The router looks up the source address in the unicast routing table to determine if the packet has arrived on the interface that is on the reverse path back to the source.
- 2 If the packet has arrived on the interface leading back to the source, the RPF check succeeds and the packet is forwarded out the interfaces present in the outgoing interface list of a multicast routing table entry.
- 3 If the RPF check in Step 2 fails, the packet is dropped.

The figure shows an example of an unsuccessful RPF check.

Figure 5: RPF Check Fails

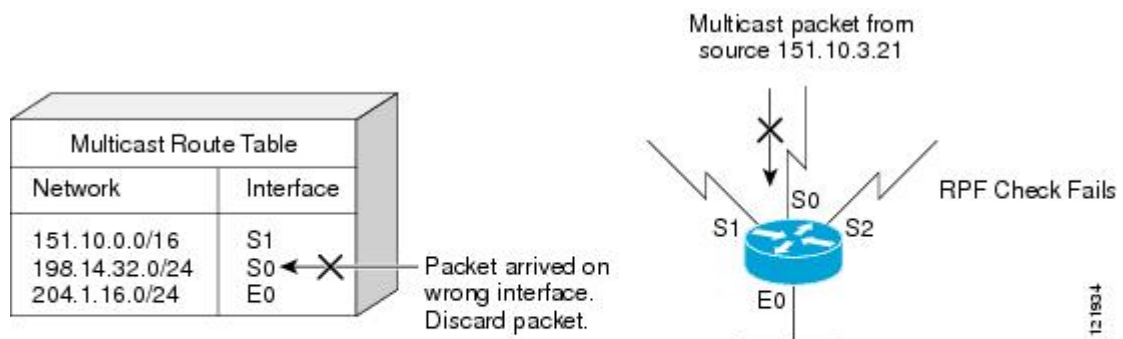

As the figure illustrates, a multicast packet from source 151.10.3.21 is received on serial interface 0 (S0). A check of the unicast route table shows that S1 is the interface this router would use to forward unicast data to 151.10.3.21. Because the packet has arrived on interface S0, the packet is discarded.

The figure shows an example of a successful RPF check.

Figure 6: RPF Check Succeeds

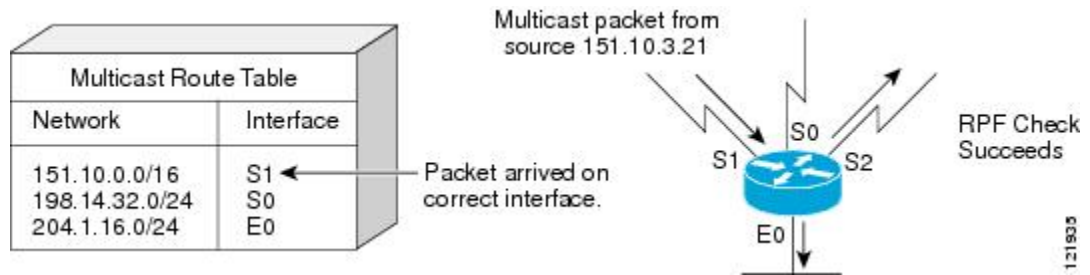

In this example, the multicast packet has arrived on interface S1. The router refers to the unicast routing table and finds that S1 is the correct interface. The RPF check passes, and the packet is forwarded.

Default PIM Routing Configuration

This table displays the default PIM routing configuration for the switch.

Table 6: Default Multicast Routing Configuration

Feature	Default Setting
Multicast routing	Disabled on all interfaces.
PIM version	Version 2.
PIM mode	No mode is defined.
PIM stub routing	None configured.
PIM RP address	None configured.
PIM domain border	Disabled.
PIM multicast boundary	None.
Candidate BSRs	Disabled.
Candidate RPs	Disabled.
Shortest-path tree threshold rate	0 kb/s.
PIM router query message interval	30 seconds.

How to Configure PIM

Enabling PIM Stub Routing

This procedure is optional.

SUMMARY STEPS

1. **enable**
2. **configure terminal**
3. **interface *interface-id***
4. **ip pim passive**
5. **end**
6. **show ip pim interface**
7. **show running-config**
8. **copy running-config startup-config**

DETAILED STEPS

	Command or Action	Purpose
Step 1	enable Example: Switch> enable	Enables privileged EXEC mode. Enter your password if prompted.
Step 2	configure terminal Example: Switch# configure terminal	Enters the global configuration mode.
Step 3	interface <i>interface-id</i> Example: Switch(config)# interface gigabitethernet 1/0/1	Specifies the interface on which you want to enable PIM stub routing, and enters interface configuration mode. The specified interface must be one of the following: <ul style="list-style-type: none"> • A routed port—A physical port that has been configured as a Layer 3 port by entering the no switchport interface configuration command. You will also need to enable IP PIM sparse-dense-mode on the interface, and join the interface as a statically connected member to an IGMP static group. For a configuration example, see Example: Interface Configuration as a Routed Port • An SVI—A VLAN interface created by using the interface vlan <i>vlan-id</i> global configuration command. You will also need to enable

	Command or Action	Purpose
		<p>IP PIM sparse-dense-mode on the VLAN, join the VLAN as a statically connected member to an IGMP static group, and then enable IGMP snooping on the VLAN, the IGMP static group, and physical interface. For a configuration example, see Example: Interface Configuration as an SVI</p> <p>These interfaces must have IP addresses assigned to them.</p>
Step 4	<p>ip pim passive</p> <p>Example:</p> <pre>Switch(config-if)# ip pim passive</pre>	Configures the PIM stub feature on the interface.
Step 5	<p>end</p> <p>Example:</p> <pre>Switch(config)# end</pre>	Returns to privileged EXEC mode.
Step 6	<p>show ip pim interface</p> <p>Example:</p> <pre>Switch# show ip pim interface</pre>	(Optional) Displays the PIM stub that is enabled on each interface.
Step 7	<p>show running-config</p> <p>Example:</p> <pre>Switch# show running-config</pre>	Verifies your entries.
Step 8	<p>copy running-config startup-config</p> <p>Example:</p> <pre>Switch# copy running-config startup-config</pre>	(Optional) Saves your entries in the configuration file.

Related Topics

[PIM Stub Routing](#), on page 47

[Example: Enabling PIM Stub Routing](#), on page 94

[Example: Verifying PIM Stub Routing](#), on page 95

[Restrictions for Configuring PIM Stub Routing](#), on page 43

Configuring a Rendezvous Point

You must have a rendezvous point (RP), if the interface is in sparse-dense mode and if you want to handle the group as a sparse group. You can use these methods:

- By manually assigning an RP to multicast groups.
- As a standalone, Cisco-proprietary protocol separate from PIMv1, which includes:
 - Setting up Auto-RP in a new internetwork
 - Adding Auto-RP to an existing sparse-mode cloud
 - Preventing join messages to false RPs
 - Filtering incoming RP announcement messages
- By using a standards track protocol in the Internet Engineering Task Force (IETF), which includes configuring PIMv2 BSR .



Note

You can use Auto-RP, BSR, or a combination of both, depending on the PIM version that you are running and the types of routers in your network. For information about working with different PIM versions in your network, see [PIMv1 and PIMv2 Interoperability](#), on page 42.

Related Topics

[Rendezvous Points](#), on page 49

Manually Assigning an RP to Multicast Groups

If the rendezvous point (RP) for a group is learned through a dynamic mechanism (such as Auto-RP or BSR), you need not perform this task for that RP.

Senders of multicast traffic announce their existence through register messages received from the source first-hop router (designated router) and forwarded to the RP. Receivers of multicast packets use RPs to join a multicast group by using explicit join messages.



Note

RPs are not members of the multicast group; they serve as a *meeting place* for multicast sources and group members.

You can configure a single RP for multiple groups defined by an access list. If there is no RP configured for a group, the multilayer switch responds to the group as dense and uses the dense-mode PIM techniques.

This procedure is optional.

SUMMARY STEPS

1. **enable**
2. **configure terminal**
3. **ip pim rp-address** *ip-address* [*access-list-number*] [**override**]
4. **access-list** *access-list-number* {**deny** | **permit**} *source* [*source-wildcard*]
5. **end**
6. **show running-config**
7. **copy running-config startup-config**

DETAILED STEPS

	Command or Action	Purpose
Step 1	enable Example: Switch> enable	Enables privileged EXEC mode. Enter your password if prompted.
Step 2	configure terminal Example: Switch# configure terminal	Enters the global configuration mode.
Step 3	ip pim rp-address <i>ip-address</i> [<i>access-list-number</i>] [override] Example: Switch(config)# ip pim rp-address 10.1.1.1 20 override	<p>Configures the address of a PIM RP.</p> <p>By default, no PIM RP address is configured. You must configure the IP address of RPs on all routers and multilayer switches (including the RP).</p> <p>Note If there is no RP configured for a group, the switch treats the group as dense, using the dense-mode PIM techniques.</p> <p>A PIM device can be an RP for more than one group. Only one RP address can be used at a time within a PIM domain. The access list conditions specify for which groups the device is an RP.</p> <ul style="list-style-type: none"> • For <i>ip-address</i>, enter the unicast address of the RP in dotted-decimal notation. • (Optional) For <i>access-list-number</i>, enter an IP standard access list number from 1 to 99. If no access list is configured, the RP is used for all groups. • (Optional) The override keyword indicates that if there is a conflict between the RP configured with this command and one learned by Auto-RP or BSR, the RP configured with this command prevails. <p>Note To remove an RP address, use the no ip pim rp-address ip-address [access-list-number] [override] global configuration command.</p>
Step 4	access-list <i>access-list-number</i> { deny permit } <i>source</i> [<i>source-wildcard</i>]	Creates a standard access list, repeating the command as many times as necessary.

	Command or Action	Purpose
	<p>Example:</p> <pre>Switch(config)# access-list 25 permit 10.5.0.1 255.224.0.0</pre>	<ul style="list-style-type: none"> • For <i>access-list-number</i>, enter the access list number specified in Step 2. • The deny keyword denies access if the conditions are matched. • The permit keyword permits access if the conditions are matched. • For <i>source</i>, enter the multicast group address for which the RP should be used. • (Optional) For <i>source-wildcard</i>, enter the wildcard bits in dotted decimal notation to be applied to the source. Place ones in the bit positions that you want to ignore. <p>The access list is always terminated by an implicit deny statement for everything.</p>
Step 5	<p>end</p> <p>Example:</p> <pre>Switch(config)# end</pre>	Returns to privileged EXEC mode.
Step 6	<p>show running-config</p> <p>Example:</p> <pre>Switch# show running-config</pre>	Verifies your entries.
Step 7	<p>copy running-config startup-config</p> <p>Example:</p> <pre>Switch# copy running-config startup-config</pre>	(Optional) Saves your entries in the configuration file.

Related Topics

[Example: Manually Assigning an RP to Multicast Groups, on page 95](#)

Setting Up Auto-RP in a New Internetwork

If you are setting up Auto-RP in a new internetwork, you do not need a default RP because you configure all the interfaces for sparse-dense mode.



Note Omit Step 3 in the following procedure, if you want to configure a PIM router as the RP for the local group.

SUMMARY STEPS

1. enable
2. show running-config
3. configure terminal
4. ip pim send-rp-announce *interface-id* scope *ttl* group-list *access-list-number* interval *seconds*
5. access-list *access-list-number* {deny | permit} source [*source-wildcard*]
6. ip pim send-rp-discovery scope *ttl*
7. end
8. show running-config
9. show ip pim rp mapping
10. show ip pim rp
11. copy running-config startup-config

DETAILED STEPS

	Command or Action	Purpose
Step 1	<p>enable</p> <p>Example:</p> <pre>Switch> enable</pre>	Enables privileged EXEC mode. Enter your password if prompted.
Step 2	<p>show running-config</p> <p>Example:</p> <pre>Switch# show running-config</pre>	<p>Verifies that a default RP is already configured on all PIM devices and the RP in the sparse-mode network. It was previously configured with the ip pim rp-address global configuration command.</p> <p>Note This step is not required for sparse-dense-mode environments.</p> <p>The selected RP should have good connectivity and be available across the network. Use this RP for the global groups (for example, 224.x.x.x and other global groups). Do not reconfigure the group address range that this RP serves. RPs dynamically discovered through Auto-RP take precedence over statically configured RPs. Assume that it is desirable to use a second RP for the local groups.</p>
Step 3	<p>configure terminal</p> <p>Example:</p> <pre>Switch# configure terminal</pre>	Enters the global configuration mode.
Step 4	<p>ip pim send-rp-announce <i>interface-id</i> scope <i>ttl</i> group-list <i>access-list-number</i> interval <i>seconds</i></p>	<p>Configures another PIM device to be the candidate RP for local groups.</p> <ul style="list-style-type: none"> • For <i>interface-id</i>, enter the interface type and number that identifies the RP address. Valid interfaces include physical ports, port channels, and VLANs.

	Command or Action	Purpose
	<p>Example:</p> <pre>Switch(config)# ip pim send-rp-announce gigabitethernet 1/0/5 scope 20 group-list 10 interval 120</pre>	<ul style="list-style-type: none"> For scope <i>ttl</i>, specify the time-to-live value in hops. Enter a hop count that is high enough so that the RP-announce messages reach all mapping agents in the network. There is no default setting. The range is 1 to 255. For group-list <i>access-list-number</i>, enter an IP standard access list number from 1 to 99. If no access list is configured, the RP is used for all groups. For interval <i>seconds</i>, specify how often the announcement messages must be sent. The default is 60 seconds. The range is 1 to 16383.
Step 5	<p>access-list <i>access-list-number</i> {deny permit} <i>source</i> [<i>source-wildcard</i>]</p> <p>Example:</p> <pre>Switch(config)# access-list 10 permit 10.10.0.0</pre>	<p>Creates a standard access list, repeating the command as many times as necessary.</p> <ul style="list-style-type: none"> For <i>access-list-number</i>, enter the access list number specified in Step 3. The deny keyword denies access if the conditions are matched. The permit keyword permits access if the conditions are matched. For <i>source</i>, enter the multicast group address range for which the RP should be used. (Optional) For <i>source-wildcard</i>, enter the wildcard bits in dotted decimal notation to be applied to the source. Place ones in the bit positions that you want to ignore. <p>Note Recall that the access list is always terminated by an implicit deny statement for everything.</p>
Step 6	<p>ip pim send-rp-discovery scope <i>ttl</i></p> <p>Example:</p> <pre>Switch(config)# ip pim send-rp-discovery scope 50</pre>	<p>Finds a switch whose connectivity is not likely to be interrupted, and assign it the role of RP-mapping agent.</p> <p>For scope <i>ttl</i>, specify the time-to-live value in hops to limit the RP discovery packets. All devices within the hop count from the source device receive the Auto-RP discovery messages. These messages tell other devices which group-to-RP mapping to use to avoid conflicts (such as overlapping group-to-RP ranges). There is no default setting. The range is 1 to 255.</p>
Step 7	<p>end</p> <p>Example:</p> <pre>Switch(config)# end</pre>	<p>Returns to privileged EXEC mode.</p>
Step 8	<p>show running-config</p> <p>Example:</p> <pre>Switch# show running-config</pre>	<p>Verifies your entries.</p>
Step 9	<p>show ip pim rp mapping</p>	<p>Displays active RPs that are cached with associated multicast routing entries.</p>

	Command or Action	Purpose
	Example: Switch# <code>show ip pim rp mapping</code>	
Step 10	<code>show ip pim rp</code> Example: Switch# <code>show ip pim rp</code>	Displays the information cached in the routing table.
Step 11	<code>copy running-config startup-config</code> Example: Switch# <code>copy running-config startup-config</code>	(Optional) Saves your entries in the configuration file.

Related Topics

[Auto-RP, on page 49](#)

[Example: Configuring Auto-RP, on page 96](#)

[Restrictions for Configuring Auto-RP and BSR, on page 43](#)

Adding Auto-RP to an Existing Sparse-Mode Cloud

This section contains suggestions for the initial deployment of Auto-RP into an existing sparse-mode cloud to minimize disruption of the existing multicast infrastructure.

This procedure is optional.

SUMMARY STEPS

1. `enable`
2. `show running-config`
3. `configure terminal`
4. `ip pim send-rp-announce interface-id scope ttl group-list access-list-number interval seconds`
5. `access-list access-list-number {deny | permit} source [source-wildcard]`
6. `ip pim send-rp-discovery scope ttl`
7. `end`
8. `show running-config`
9. `show ip pim rp mapping`
10. `show ip pim rp`
11. `copy running-config startup-config`

DETAILED STEPS

	Command or Action	Purpose
Step 1	<p>enable</p> <p>Example:</p> <pre>Switch> enable</pre>	Enables privileged EXEC mode. Enter your password if prompted.
Step 2	<p>show running-config</p> <p>Example:</p> <pre>Switch# show running-config</pre>	<p>Verifies that a default RP is already configured on all PIM devices and the RP in the sparse-mode network. It was previously configured with the ip pim rp-address global configuration command.</p> <p>Note This step is not required for sparse-dense-mode environments.</p> <p>The selected RP should have good connectivity and be available across the network. Use this RP for the global groups (for example, 224.x.x.x and other global groups). Do not reconfigure the group address range that this RP serves. RPs dynamically discovered through Auto-RP take precedence over statically configured RPs. Assume that it is desirable to use a second RP for the local groups.</p>
Step 3	<p>configure terminal</p> <p>Example:</p> <pre>Switch# configure terminal</pre>	Enters the global configuration mode.
Step 4	<p>ip pim send-rp-announce <i>interface-id</i> scope <i>ttl</i> group-list <i>access-list-number</i> interval <i>seconds</i></p> <p>Example:</p> <pre>Switch(config)# ip pim send-rp-announce gigabitethernet 1/0/5 scope 20 group-list 10 interval 120</pre>	<p>Configures another PIM device to be the candidate RP for local groups.</p> <ul style="list-style-type: none"> • For <i>interface-id</i>, enter the interface type and number that identifies the RP address. Valid interfaces include physical ports, port channels, and VLANs. • For scope <i>ttl</i>, specify the time-to-live value in hops. Enter a hop count that is high enough so that the RP-announce messages reach all mapping agents in the network. There is no default setting. The range is 1 to 255. • For group-list <i>access-list-number</i>, enter an IP standard access list number from 1 to 99. If no access list is configured, the RP is used for all groups. • For interval <i>seconds</i>, specify how often the announcement messages must be sent. The default is 60 seconds. The range is 1 to 16383. <p>Note To remove the PIM device configured as the candidate RP, use the no ip pim send-rp-announce <i>interface-id</i> global configuration command.</p>
Step 5	<p>access-list <i>access-list-number</i> {deny permit} <i>source</i> [<i>source-wildcard</i>]</p> <p>Example:</p> <pre>Switch(config)# access-list 10</pre>	<p>Creates a standard access list, repeating the command as many times as necessary.</p> <ul style="list-style-type: none"> • For <i>access-list-number</i>, enter the access list number specified in Step 3. • The deny keyword denies access if the conditions are matched.

	Command or Action	Purpose
	<code>permit 224.0.0.0 15.255.255.255</code>	<ul style="list-style-type: none"> The permit keyword permits access if the conditions are matched. For <i>source</i>, enter the multicast group address range for which the RP should be used. (Optional) For <i>source-wildcard</i>, enter the wildcard bits in dotted decimal notation to be applied to the source. Place ones in the bit positions that you want to ignore. <p>Recall that the access list is always terminated by an implicit deny statement for everything.</p>
Step 6	<p>ip pim send-rp-discovery scope <i>ttl</i></p> <p>Example:</p> <pre>Switch(config)# ip pim send-rp-discovery scope 50</pre>	<p>Finds a switch whose connectivity is not likely to be interrupted, and assigns it the role of RP-mapping agent.</p> <p>For scope <i>ttl</i>, specify the time-to-live value in hops to limit the RP discovery packets. All devices within the hop count from the source device receive the Auto-RP discovery messages. These messages tell other devices which group-to-RP mapping to use to avoid conflicts (such as overlapping group-to-RP ranges). There is no default setting. The range is 1 to 255.</p> <p>Note To remove the switch as the RP-mapping agent, use the no ip pim send-rp-discovery global configuration command.</p>
Step 7	<p>end</p> <p>Example:</p> <pre>Switch(config)# end</pre>	Returns to privileged EXEC mode.
Step 8	<p>show running-config</p> <p>Example:</p> <pre>Switch# show running-config</pre>	Verifies your entries.
Step 9	<p>show ip pim rp mapping</p> <p>Example:</p> <pre>Switch# show ip pim rp mapping</pre>	Displays active RPs that are cached with associated multicast routing entries.
Step 10	<p>show ip pim rp</p> <p>Example:</p> <pre>Switch# show ip pim rp</pre>	Displays the information cached in the routing table.

	Command or Action	Purpose
Step 11	copy running-config startup-config Example: Switch# copy running-config startup-config	(Optional) Saves your entries in the configuration file.

Related Topics

[PIM Sparse Mode, on page 45](#)

Configuring Sparse Mode with a Single Static RP

A rendezvous point (RP) is required in networks running Protocol Independent Multicast sparse mode (PIM-SM). In PIM-SM, traffic will be forwarded only to network segments with active receivers that have explicitly requested multicast data.

This section describes how to configure sparse mode with a single static RP.

Before You Begin

All access lists that are needed when sparse mode is configured with a single static RP should be configured prior to beginning the configuration task.

SUMMARY STEPS

1. **enable**
2. **configure terminal**
3. **ip multicast-routing [distributed]**
4. **interface** *type number*
5. **ip pim sparse-mode**
6. Repeat Steps 1 through 5 on every interface that uses IP multicast.
7. **exit**
8. **ip pim rp-address** *rp-address* [*access-list*] [**override**]
9. **end**
10. **show ip pim rp** [**mapping**] [*rp-address*]
11. **show ip igmp groups** [*group-name* | *group-address*] [*interface-type interface-number*] [**detail**]
12. **show ip mroute**
13. **copy running-config startup-config**

DETAILED STEPS

	Command or Action	Purpose
Step 1	<p>enable</p> <p>Example:</p> <pre>Switch> enable</pre>	<p>Enables privileged EXEC mode.</p> <ul style="list-style-type: none"> • Enter your password if prompted.
Step 2	<p>configure terminal</p> <p>Example:</p> <pre>Switch# configure terminal</pre>	<p>Enters global configuration mode.</p>
Step 3	<p>ip multicast-routing [distributed]</p> <p>Example:</p> <pre>Switch(config)# ip multicast-routing</pre>	<p>Enables IP multicast routing.</p> <ul style="list-style-type: none"> • Use the distributed keyword to enable Multicast Distributed Switching.
Step 4	<p>interface type number</p> <p>Example:</p> <pre>Switch(config)# interface gigabitethernet 1/0/0</pre>	<p>Selects an interface that is connected to hosts on which PIM can be enabled.</p>
Step 5	<p>ip pim sparse-mode</p> <p>Example:</p> <pre>Switch(config-if)# ip pim sparse-mode</pre>	<p>Enables PIM on an interface. You must use sparse mode.</p>
Step 6	<p>Repeat Steps 1 through 5 on every interface that uses IP multicast.</p>	--
Step 7	<p>exit</p> <p>Example:</p> <pre>Switch(config-if)# exit</pre>	<p>Returns to global configuration mode.</p>
Step 8	<p>ip pim rp-address rp-address [access-list] [override]</p> <p>Example:</p> <pre>Switch(config)# ip pim rp-address 192.168.0.0</pre>	<p>Configures the address of a PIM RP for a particular group.</p> <ul style="list-style-type: none"> • The optional <i>access-list</i> argument is used to specify the number or name a standard access list that defines the multicast groups to be statically mapped to the RP. <p>Note If no access list is defined, the RP will map to all multicast groups, 224/4.</p> <ul style="list-style-type: none"> • The optional override keyword is used to specify that if dynamic and static group-to-RP mappings are used together

	Command or Action	Purpose
		<p>and there is an RP address conflict, the RP address configured for a static group-to-RP mapping will take precedence.</p> <p>Note If the override keyword is not specified and there is RP address conflict, dynamic group-to-RP mappings will take precedence over static group-to-RP mappings.</p>
Step 9	<p>end</p> <p>Example:</p> <pre>Switch(config)# end</pre>	Ends the current configuration session and returns to EXEC mode.
Step 10	<p>show ip pim rp [mapping] [rp-address]</p> <p>Example:</p> <pre>Switch# show ip pim rp mapping</pre>	(Optional) Displays RPs known in the network and shows how the router learned about each RP.
Step 11	<p>show ip igmp groups [group-name group-address interface-type interface-number] [detail]</p> <p>Example:</p> <pre>Switch# show ip igmp groups</pre>	<p>(Optional) Displays the multicast groups having receivers that are directly connected to the router and that were learned through IGMP.</p> <ul style="list-style-type: none"> • A receiver must be active on the network at the time that this command is issued in order for receiver information to be present on the resulting display.
Step 12	<p>show ip mroute</p> <p>Example:</p> <pre>Switch# show ip mroute</pre>	(Optional) Displays the contents of the IP mroute table.
Step 13	<p>copy running-config startup-config</p> <p>Example:</p> <pre>Switch# copy running-config startup-config</pre>	(Optional) Saves your entries in the configuration file.

Related Topics

[PIM Sparse Mode, on page 45](#)

Preventing Join Messages to False RPs

Determine whether the **ip pim accept-rp** command was previously configured throughout the network by using the **show running-config** privileged EXEC command. If the **ip pim accept-rp** command is not configured

on any device, this problem can be addressed later. In those routers or multilayer switches already configured with the **ip pim accept-rp** command, you must enter the command again to accept the newly advertised RP.

To accept all RPs advertised with Auto-RP and reject all other RPs by default, use the **ip pim accept-rp auto-rp** global configuration command.

If all interfaces are in sparse mode, use a default-configured RP to support the two well-known groups 224.0.1.39 and 224.0.1.40. Auto-RP uses these two well-known groups to collect and distribute RP-mapping information. When this is the case and the **ip pim accept-rp auto-rp** command is configured, another **ip pim accept-rp** command accepting the RP must be configured as follows:

```
Switch(config)# ip pim accept-rp 172.10.20.1 1
Switch(config)# access-list 1 permit 224.0.1.39
Switch(config)# access-list 1 permit 224.0.1.40
```

This procedure is optional.

Related Topics

[Example: Preventing Join Messages to False RPs, on page 97](#)

Filtering Incoming RP Announcement Messages

You can add configuration commands to the mapping agents to prevent a maliciously configured router from masquerading as a candidate RP and causing problems.

This procedure is optional.

SUMMARY STEPS

1. **enable**
2. **configure terminal**
3. **ip pim rp-announce-filter rp-list *access-list-number* group-list *access-list-number***
4. **access-list *access-list-number* {deny | permit} source [*source-wildcard*]**
5. **end**
6. **show running-config**
7. **copy running-config startup-config**

DETAILED STEPS

	Command or Action	Purpose
Step 1	enable Example: Switch> enable	Enables privileged EXEC mode. Enter your password if prompted.

	Command or Action	Purpose
Step 2	<p>configure terminal</p> <p>Example:</p> <pre>Switch# configure terminal</pre>	Enters the global configuration mode.
Step 3	<p>ip pim rp-announce-filter rp-list access-list-number group-list access-list-number</p> <p>Example:</p> <pre>Switch(config)# ip pim rp-announce-filter rp-list 10 group-list 14</pre>	<p>Filters incoming RP announcement messages.</p> <p>Enter this command on each mapping agent in the network. Without this command, all incoming RP-announce messages are accepted by default.</p> <p>For rp-list access-list-number, configure an access list of candidate RP addresses that, if permitted, is accepted for the group ranges supplied in the group-list access-list-number variable. If this variable is omitted, the filter applies to all multicast groups.</p> <p>If more than one mapping agent is used, the filters must be consistent across all mapping agents to ensure that no conflicts occur in the group-to-RP mapping information.</p> <p>Note To remove a filter on incoming RP announcement messages, use the no ip pim rp-announce-filter rp-list access-list-number [group-list access-list-number] global configuration command.</p>
Step 4	<p>access-list access-list-number {deny permit} source [source-wildcard]</p> <p>Example:</p> <pre>Switch(config)# access-list 10 permit 10.8.1.0 255.255.224.0</pre>	<p>Creates a standard access list, repeating the command as many times as necessary.</p> <ul style="list-style-type: none"> • For <i>access-list-number</i>, enter the access list number specified in Step 2. • The deny keyword denies access if the conditions are matched. • The permit keyword permits access if the conditions are matched. • Create an access list that specifies from which routers and multilayer switches the mapping agent accepts candidate RP announcements (rp-list ACL). • Create an access list that specifies the range of multicast groups from which to accept or deny (group-list ACL). • For <i>source</i>, enter the multicast group address range for which the RP should be used. • (Optional) For <i>source-wildcard</i>, enter the wildcard bits in dotted decimal notation to be applied to the source. Place ones in the bit positions that you want to ignore. <p>The access list is always terminated by an implicit deny statement for everything.</p>

	Command or Action	Purpose
Step 5	end Example: Switch(config)# end	Returns to privileged EXEC mode.
Step 6	show running-config Example: Switch# show running-config	Verifies your entries.
Step 7	copy running-config startup-config Example: Switch# copy running-config startup-config	(Optional) Saves your entries in the configuration file.

Related Topics

[Example: Filtering Incoming RP Announcement Messages, on page 96](#)

Configuring PIMv2 BSR

The process for configuring PIMv2 BSR may involve the following optional tasks:

- Defining the PIM domain border
- Defining the IP multicast boundary
- Configuring candidate BSRs
- Configuring candidate RPs

Defining the PIM Domain Border

Perform the following steps to configure the PIM domain border. This procedure is optional.

SUMMARY STEPS

1. **enable**
2. **configure terminal**
3. **interface** *interface-id*
4. **ip pim bsr-border**
5. **end**
6. **show running-config**
7. **copy running-config startup-config**

DETAILED STEPS

	Command or Action	Purpose
Step 1	enable Example: Switch> enable	Enables privileged EXEC mode. Enter your password if prompted.
Step 2	configure terminal Example: Switch# configure terminal	Enters the global configuration mode.
Step 3	interface <i>interface-id</i> Example: Switch(config)# interface gigabitethernet 1/0/1	<p>Specifies the interface to be configured, and enters interface configuration mode.</p> <p>The specified interface must be one of the following:</p> <ul style="list-style-type: none"> • A routed port—A physical port that has been configured as a Layer 3 port by entering the no switchport interface configuration command. You will also need to enable IP PIM sparse-dense-mode on the interface, and join the interface as a statically connected member to an IGMP static group. For a configuration example, see Example: Interface Configuration as a Routed Port • An SVI—A VLAN interface created by using the interface vlan <i>vlan-id</i> global configuration command. You will also need to enable IP PIM sparse-dense-mode on the VLAN, join the VLAN as a statically connected member to an IGMP static group, and then enable IGMP snooping on the VLAN, the IGMP static group, and physical interface. For a configuration example, see Example: Interface Configuration as an SVI <p>These interfaces must have IP addresses assigned to them.</p>
Step 4	ip pim bsr-border	Defines a PIM bootstrap message boundary for the PIM domain.

	Command or Action	Purpose
	<p>Example:</p> <pre>Switch(config-if)# ip pim bsr-border</pre>	<p>Enter this command on each interface that connects to other bordering PIM domains. This command instructs the switch to neither send nor receive PIMv2 BSR messages on this interface.</p> <p>Note To remove the PIM border, use the no ip pim bsr-border interface configuration command.</p>
Step 5	<p>end</p> <p>Example:</p> <pre>Switch(config)# end</pre>	Returns to privileged EXEC mode.
Step 6	<p>show running-config</p> <p>Example:</p> <pre>Switch# show running-config</pre>	Verifies your entries.
Step 7	<p>copy running-config startup-config</p> <p>Example:</p> <pre>Switch# copy running-config startup-config</pre>	(Optional) Saves your entries in the configuration file.

Related Topics

[PIM Domain Border, on page 51](#)

Defining the IP Multicast Boundary

You define a multicast boundary to prevent Auto-RP messages from entering the PIM domain. You create an access list to deny packets destined for 224.0.1.39 and 224.0.1.40, which carry Auto-RP information.

This procedure is optional.

SUMMARY STEPS

1. **enable**
2. **configure terminal**
3. **access-list** *access-list-number* **deny** *source* [*source-wildcard*]
4. **interface** *interface-id*
5. **ip multicast boundary** *access-list-number*
6. **end**
7. **show running-config**
8. **copy running-config startup-config**

DETAILED STEPS

	Command or Action	Purpose
Step 1	<p>enable</p> <p>Example:</p> <pre>Switch> enable</pre>	Enables privileged EXEC mode. Enter your password if prompted.
Step 2	<p>configure terminal</p> <p>Example:</p> <pre>Switch# configure terminal</pre>	Enters the global configuration mode.
Step 3	<p>access-list <i>access-list-number</i> deny <i>source</i> [<i>source-wildcard</i>]</p> <p>Example:</p> <pre>Switch(config)# access-list 12 deny 224.0.1.39 access-list 12 deny 224.0.1.40</pre>	<p>Creates a standard access list, repeating the command as many times as necessary.</p> <ul style="list-style-type: none"> • For <i>access-list-number</i>, the range is 1 to 99. • The deny keyword denies access if the conditions are matched. • For <i>source</i>, enter multicast addresses 224.0.1.39 and 224.0.1.40, which carry Auto-RP information. • (Optional) For <i>source-wildcard</i>, enter the wildcard bits in dotted decimal notation to be applied to the source. Place ones in the bit positions that you want to ignore. <p>The access list is always terminated by an implicit deny statement for everything.</p>
Step 4	<p>interface <i>interface-id</i></p> <p>Example:</p> <pre>Switch(config)# interface gigabitethernet 1/0/1</pre>	<p>Specifies the interface to be configured, and enters interface configuration mode.</p> <p>The specified interface must be one of the following:</p> <ul style="list-style-type: none"> • A routed port—A physical port that has been configured as a Layer 3 port by entering the no switchport interface configuration command. You will also need to enable IP PIM sparse-dense-mode on the interface,

	Command or Action	Purpose
		<p>and join the interface as a statically connected member to an IGMP static group. For a configuration example, see Example: Interface Configuration as a Routed Port</p> <ul style="list-style-type: none"> An SVI—A VLAN interface created by using the interface vlan <i>vlan-id</i> global configuration command. You will also need to enable IP PIM sparse-dense-mode on the VLAN, join the VLAN as a statically connected member to an IGMP static group, and then enable IGMP snooping on the VLAN, the IGMP static group, and physical interface. For a configuration example, see Example: Interface Configuration as an SVI <p>These interfaces must have IP addresses assigned to them.</p>
Step 5	<p>ip multicast boundary <i>access-list-number</i></p> <p>Example:</p> <pre>Switch(config-if)# ip multicast boundary 12</pre>	<p>Configures the boundary, specifying the access list you created in Step 2.</p> <p>Note To remove the boundary, use the no ip multicast boundary interface configuration command.</p>
Step 6	<p>end</p> <p>Example:</p> <pre>Switch(config)# end</pre>	Returns to privileged EXEC mode.
Step 7	<p>show running-config</p> <p>Example:</p> <pre>Switch# show running-config</pre>	Verifies your entries.
Step 8	<p>copy running-config startup-config</p> <p>Example:</p> <pre>Switch# copy running-config startup-config</pre>	(Optional) Saves your entries in the configuration file.

Related Topics

[Example: Defining the IP Multicast Boundary to Deny Auto-RP Information](#), on page 96

Configuring Candidate BSRs

You can configure one or more candidate BSRs. The devices serving as candidate BSRs should have good connectivity to other devices and be in the backbone portion of the network.

This procedure is optional.

SUMMARY STEPS

1. **enable**
2. **configure terminal**
3. **ip pim bsr-candidate** *interface-id* *hash-mask-length* [*priority*]
4. **end**
5. **show running-config**
6. **copy running-config startup-config**

DETAILED STEPS

	Command or Action	Purpose
Step 1	enable Example: Switch> enable	Enables privileged EXEC mode. Enter your password if prompted.
Step 2	configure terminal Example: Switch# configure terminal	Enters the global configuration mode.
Step 3	ip pim bsr-candidate <i>interface-id</i> <i>hash-mask-length</i> [<i>priority</i>] Example: Switch(config)# ip pim bsr-candidate gigabitethernet 1/0/3 28 100	Configures your switch to be a candidate BSR. <ul style="list-style-type: none"> • For <i>interface-id</i>, enter the interface on this switch from which the BSR address is derived to make it a candidate. This interface must be enabled with PIM. Valid interfaces include physical ports, port channels, and VLANs. • For <i>hash-mask-length</i>, specify the mask length (32 bits maximum) that is to be ANDed with the group address before the hash function is called. All groups with the same seed hash correspond to the same RP. For example, if this value is 24, only the first 24 bits of the group addresses matter. • (Optional) For <i>priority</i>, enter a number from 0 to 255. The BSR with the larger priority is preferred. If the priority values are the same, the device with the highest IP address is selected as the BSR. The default is 0.

	Command or Action	Purpose
		Note To remove this device as a candidate BSR, use the no ip pim bsr-candidate global configuration command.
Step 4	end Example: Switch(config)# end	Returns to privileged EXEC mode.
Step 5	show running-config Example: Switch# show running-config	Verifies your entries.
Step 6	copy running-config startup-config Example: Switch# copy running-config startup-config	(Optional) Saves your entries in the configuration file.

Related Topics

[Bootstrap Router, on page 50](#)

[Example: Configuring Candidate BSRs, on page 97](#)

[Restrictions for Configuring Auto-RP and BSR, on page 43](#)

Configuring the Candidate RPs

You can configure one or more candidate RPs. Similar to BSRs, the RPs should also have good connectivity to other devices and be in the backbone portion of the network. An RP can serve the entire IP multicast address space or a portion of it. Candidate RPs send candidate RP advertisements to the BSR.

This procedure is optional.

Before You Begin

When deciding which devices should be RPs, consider these options:

- In a network of Cisco routers and multilayer switches where only Auto-RP is used, any device can be configured as an RP.
- In a network that includes only Cisco PIMv2 routers and multilayer switches and with routers from other vendors, any device can be used as an RP.
- In a network of Cisco PIMv1 routers, Cisco PIMv2 routers, and routers from other vendors, configure only Cisco PIMv2 routers and multilayer switches as RPs.

SUMMARY STEPS

1. **enable**
2. **configure terminal**
3. **ip pim rp-candidate** *interface-id* [**group-list** *access-list-number*]
4. **access-list** *access-list-number* {**deny** | **permit**} *source* [*source-wildcard*]
5. **end**
6. **show running-config**
7. **copy running-config startup-config**

DETAILED STEPS

	Command or Action	Purpose
Step 1	enable Example: Switch> enable	Enables privileged EXEC mode. Enter your password if prompted.
Step 2	configure terminal Example: Switch# configure terminal	Enters the global configuration mode.
Step 3	ip pim rp-candidate <i>interface-id</i> [group-list <i>access-list-number</i>] Example: Switch(config)# ip pim rp-candidate gigabitethernet 1/0/5 group-list 10	Configures your switch to be a candidate RP. <ul style="list-style-type: none"> • For <i>interface-id</i>, specify the interface whose associated IP address is advertised as a candidate RP address. Valid interfaces include physical ports, port channels, and VLANs. • (Optional) For group-list <i>access-list-number</i>, enter an IP standard access list number from 1 to 99. If no group-list is specified, the switch is a candidate RP for all groups. <p>Note To remove this device as a candidate RP, use the no ip pim rp-candidate <i>interface-id</i> global configuration command.</p>
Step 4	access-list <i>access-list-number</i> { deny permit } <i>source</i> [<i>source-wildcard</i>] Example: Switch(config)# access-list 10 permit 239.0.0.0 0.255.255.255	Creates a standard access list, repeating the command as many times as necessary. <ul style="list-style-type: none"> • For <i>access-list-number</i>, enter the access list number specified in Step 2. • The deny keyword denies access if the conditions are matched. The permit keyword permits access if the conditions are matched. • For <i>source</i>, enter the number of the network or host from which the packet is being sent.

	Command or Action	Purpose
		<ul style="list-style-type: none"> (Optional) For <i>source-wildcard</i>, enter the wildcard bits in dotted decimal notation to be applied to the source. Place ones in the bit positions that you want to ignore. <p>The access list is always terminated by an implicit deny statement for everything.</p>
Step 5	end Example: Switch(config)# end	Returns to privileged EXEC mode.
Step 6	show running-config Example: Switch# show running-config	Verifies your entries.
Step 7	copy running-config startup-config Example: Switch# copy running-config startup-config	(Optional) Saves your entries in the configuration file.

Related Topics

[Example: Configuring Candidate RPs, on page 97](#)

Delaying the Use of PIM Shortest-Path Tree

Perform these steps to configure a traffic rate threshold that must be reached before multicast routing is switched from the source tree to the shortest-path tree.

This procedure is optional.

SUMMARY STEPS

1. **enable**
2. **configure terminal**
3. **access-list** *access-list-number* {deny | permit} *source* [*source-wildcard*]
4. **ip pim spt-threshold** {*kbps* | infinity} [**group-list** *access-list-number*]
5. **end**
6. **show running-config**
7. **copy running-config startup-config**

DETAILED STEPS

	Command or Action	Purpose
Step 1	enable Example: Switch> enable	Enables privileged EXEC mode. Enter your password if prompted.
Step 2	configure terminal Example: Switch# configure terminal	Enters global configuration mode.
Step 3	access-list <i>access-list-number</i> {deny permit} <i>source</i> [<i>source-wildcard</i>] Example: Switch(config)# access-list 16 permit 225.0.0.0 0.255.255.255	<p>Creates a standard access list.</p> <ul style="list-style-type: none"> • For <i>access-list-number</i>, the range is 1 to 99. • The deny keyword denies access if the conditions are matched. • The permit keyword permits access if the conditions are matched. • For <i>source</i>, specify the multicast group to which the threshold will apply. • (Optional) For <i>source-wildcard</i>, enter the wildcard bits in dotted decimal notation to be applied to the source. Place ones in the bit positions that you want to ignore. <p>The access list is always terminated by an implicit deny statement for everything.</p>
Step 4	ip pim spt-threshold { <i>kbps</i> infinity} [group-list <i>access-list-number</i>] Example: Switch(config)# ip pim spt-threshold	<p>Specifies the threshold that must be reached before moving to shortest-path tree (spt).</p> <ul style="list-style-type: none"> • For <i>kbps</i>, specify the traffic rate in kilobits per second. The default is 0 kbps. <p>Note Because of switch hardware limitations, 0 kbps is the only valid entry even though the range is 0 to 4294967.</p>

	Command or Action	Purpose
	<code>infinity group-list 16</code>	<ul style="list-style-type: none"> Specify infinity if you want all sources for the specified group to use the shared tree, never switching to the source tree. (Optional) For group-list <i>access-list-number</i>, specify the access list created in Step 2. If the value is 0 or if the group list is not used, the threshold applies to all groups. <p>Note To return to the default setting, use the no ip pim spt-threshold {kbps infinity} global configuration command.</p>
Step 5	end Example: Switch(config)# end	Returns to privileged EXEC mode.
Step 6	show running-config Example: Switch# show running-config	Verifies your entries.
Step 7	copy running-config startup-config Example: Switch# copy running-config startup-config	(Optional) Saves your entries in the configuration file.

Related Topics

[PIM Shared Tree and Source Tree, on page 54](#)

Modifying the PIM Router-Query Message Interval

PIM routers and multilayer switches send PIM router-query messages to find which device will be the designated router (DR) for each LAN segment (subnet). The DR is responsible for sending IGMP host-query messages to all hosts on the directly connected LAN.

With PIM DM operation, the DR has meaning only if IGMPv1 is in use. IGMPv1 does not have an IGMP querier election process, so the elected DR functions as the IGMP querier. With PIM-SM operation, the DR is the device that is directly connected to the multicast source. It sends PIM register messages to notify the RP that multicast traffic from a source needs to be forwarded down the shared tree. In this case, the DR is the device with the highest IP address.

This procedure is optional.

SUMMARY STEPS

1. **enable**
2. **configure terminal**
3. **interface** *interface-id*
4. **ip pim query-interval** *seconds*
5. **end**
6. **show ip igmp interface** [*interface-id*]
7. **copy running-config startup-config**

DETAILED STEPS

	Command or Action	Purpose
Step 1	enable Example: Switch> enable	Enables privileged EXEC mode. Enter your password if prompted.
Step 2	configure terminal Example: Switch# configure terminal	Enters the global configuration mode.
Step 3	interface <i>interface-id</i> Example: Switch(config)# interface gigabitethernet 1/0/1	<p>Specifies the interface to be configured, and enters interface configuration mode.</p> <p>The specified interface must be one of the following:</p> <ul style="list-style-type: none"> • A routed port—A physical port that has been configured as a Layer 3 port by entering the no switchport interface configuration command. You will also need to enable IP PIM sparse-dense-mode on the interface, and join the interface as a statically connected member to an IGMP static group. For a configuration example, see Example: Interface Configuration as a Routed Port • An SVI—A VLAN interface created by using the interface vlan <i>vlan-id</i> global configuration command. You will also need to enable IP PIM sparse-dense-mode on the VLAN, join the VLAN as a statically connected member to an IGMP static group, and then enable IGMP snooping on the VLAN, the IGMP static group, and physical interface. For a configuration example, see Example: Interface Configuration as an SVI <p>These interfaces must have IP addresses assigned to them.</p>

	Command or Action	Purpose
Step 4	ip pim query-interval <i>seconds</i> Example: <pre>Switch(config-if)# ip pim query-interval 45</pre>	Configures the frequency at which the switch sends PIM router-query messages. The default is 30 seconds. The range is 1 to 65535. Note To return to the default setting, use the no ip pim query-interval [seconds] interface configuration command.
Step 5	end Example: <pre>Switch(config)# end</pre>	Returns to privileged EXEC mode.
Step 6	show ip igmp interface [<i>interface-id</i>] Example: <pre>Switch# show ip igmp interface</pre>	Verifies your entries.
Step 7	copy running-config startup-config Example: <pre>Switch# copy running-config startup-config</pre>	(Optional) Saves your entries in the configuration file.

Verifying PIM Operations

Verifying IP Multicast Operation in a PIM-SM or a PIM-SSM Network

When you verify the operation of IP multicast in a PIM-SM network environment or in a PIM-SSM network environment, a useful approach is to begin the verification process on the last hop router, and then continue the verification process on the routers along the SPT until the first hop router has been reached. The goal of the verification is to ensure that IP multicast traffic is being routed properly through an IP multicast network.

Perform the following optional tasks to verify IP multicast operation in a PIM-SM or a PIM-SSM network. The steps in these tasks help to locate a faulty hop when sources and receivers are not operating as expected.



Note

If packets are not reaching their expected destinations, you might want consider disabling IP multicast fast switching, which would place the router in process switching mode. If packets begin reaching their proper destinations after IP multicast fast switching has been disabled, then the issue most likely was related to IP multicast fast switching.

Verifying IP Multicast on the First Hop Router

Enter these commands on the first hop router to verify IP multicast operations on the first hop router:

SUMMARY STEPS

1. **enable**
2. **show ip mroute** [*group-address*]
3. **show ip mroute active** [*kb/s*]

DETAILED STEPS

	Command or Action	Purpose
Step 1	enable Example: Switch> enable	Enables privileged EXEC mode. Enter your password if prompted.
Step 2	show ip mroute [<i>group-address</i>] Example: Switch# show ip mroute 239.1.2.3 (*, 239.1.2.3), 00:18:10/stopped, RP 172.16.0.1, flags: SPF Incoming interface: Serial1/0, RPF nbr 172.31.200.2 Outgoing interface list: Null (10.0.0.1, 239.1.2.3), 00:18:10/00:03:22, flags: FT Incoming interface: GigabitEthernet0/0/0, RPF nbr 0.0.0.0 Outgoing interface list: Serial1/0, Forward/Sparse-Dense, 00:18:10/00:03:19	Confirms that the F flag has been set for mroutes on the first hop router.
Step 3	show ip mroute active [<i>kb/s</i>] Example: Switch# show ip mroute active Active IP Multicast Sources - sending >= 4 kbps Group: 239.1.2.3, (?) Source: 10.0.0.1 (?) Rate: 20 pps/4 kbps(1sec), 4 kbps(last 30 secs), 4 kbps(life avg)	Displays information about active multicast sources sending to groups. The output of this command provides information about the multicast packet rate for active sources. Note By default, the output of the show ip mroute command with the active keyword displays information about active sources sending traffic to groups at a rate greater than or equal to 4 kb/s. To display information about active sources sending low-rate traffic to groups (that is, traffic less than 4 kb/s), specify a value of 1 for the <i>kb/s</i> argument. Specifying a value of 1 for this argument displays information about active sources sending traffic to groups at a rate equal to or greater than 1 kb/s, which effectively displays information about all possible active source traffic.

Verifying IP Multicast on Routers Along the SPT

Enter these commands on routers along the SPT to verify IP multicast operations on routers along the SPT in a PIM-SM or PIM-SSM network:

SUMMARY STEPS

1. **enable**
2. **show ip mroute** *[group-address]*
3. **show ip mroute active**

DETAILED STEPS

	Command or Action	Purpose
Step 1	enable Example: Switch> enable	Enables privileged EXEC mode. Enter your password if prompted.
Step 2	show ip mroute <i>[group-address]</i> Example: Switch# show ip mroute 239.1.2.3 (*, 239.1.2.3), 00:17:56/00:03:02, RP 172.16.0.1, flags: S Incoming interface: Null, RPF nbr 0.0.0.0 Outgoing interface list: GigabitEthernet0/0/0, Forward/Sparse-Dense, 00:17:56/00:03:02 (10.0.0.1, 239.1.2.3), 00:15:34/00:03:28, flags: T Incoming interface: Serial1/0, RPF nbr 172.31.200.1 Outgoing interface list: GigabitEthernet0/0/0, Forward/Sparse-Dense, 00:15:34/00:03:02	Confirms the RPF neighbor towards the source for a particular group or groups.
Step 3	show ip mroute active Example: Switch# show ip mroute active Active IP Multicast Sources - sending >= 4 kbps	Displays information about active multicast sources sending to groups. The output of this command provides information about the multicast packet rate for active sources.

	Command or Action	Purpose
	<pre>Group: 239.1.2.3, (?) Source: 10.0.0.1 (?) Rate: 20 pps/4 kbps(1sec), 4 kbps(last 30 secs), 4 kbps(life avg)</pre>	<p>Note By default, the output of the show ip mroute command with the active keyword displays information about active sources sending traffic to groups at a rate greater than or equal to 4 kb/s. To display information about active sources sending low-rate traffic to groups (that is, traffic less than 4 kb/s), specify a value of 1 for the <i>kb/s</i> argument. Specifying a value of 1 for this argument displays information about active sources sending traffic to groups at a rate equal to or greater than 1 kb/s, which effectively displays information about all possible active source traffic.</p>

Verifying IP Multicast Operation on the Last Hop Router

Enter these commands on the last hop router to verify IP multicast operations on the last hop router:

SUMMARY STEPS

1. **enable**
2. **show ip igmp groups**
3. **show ip pim rp mapping**
4. **show ip mroute**
5. **show ip interface** [*type number*]
6. **show ip pim interface count**
7. **show ip mroute count**
8. **show ip mroute active** [*kb/s*]

DETAILED STEPS

	Command or Action	Purpose
Step 1	<pre>enable</pre> <p>Example:</p> <pre>Switch> enable</pre>	Enables privileged EXEC mode. Enter your password if prompted.
Step 2	<pre>show ip igmp groups</pre> <p>Example:</p> <pre>Switch# show ip igmp groups IGMP Connected Group Membership Group Address Interface Uptime Expires Last Reporter 239.1.2.3 GigabitEthernet1/0/0 00:05:14 00:02:14</pre>	Verifies IGMP memberships on the last hop router. This information will confirm the multicast groups with receivers that are directly connected to the last hop router and that are learned through IGMP.

	Command or Action	Purpose
	<pre> 10.1.0.6 224.0.1.39 GigabitEthernet0/0/0 00:09:11 00:02:08 172.31.100.1 </pre>	
Step 3	<p>show ip pim rp mapping</p> <p>Example:</p> <pre> Switch# show ip pim rp mapping PIM Group-to-RP Mappings Group(s) 224.0.0.0/4 RP 172.16.0.1 (?), v2v1 Info source: 172.16.0.1 (?), elected via Auto-RP Uptime: 00:09:11, expires: 00:02:47 </pre>	<p>Confirms that the group-to-RP mappings are being populated correctly on the last hop router.</p> <p>Note Ignore this step if you are verifying a last hop router in a PIM-SSM network. The show ip pim rp mapping command does not work with routers in a PIM-SSM network because PIM-SSM does not use RPs. In addition, if configured correctly, PIM-SSM groups do not appear in the output of the show ip pim rp mapping command.</p>
Step 4	<p>show ip mroute</p> <p>Example:</p> <pre> Switch# show ip mroute (*, 239.1.2.3), 00:05:14/00:03:04, RP 172.16.0.1, flags: SJC Incoming interface: GigabitEthernet0/0/0, RPF nbr 172.31.100.1 Outgoing interface list: GigabitEthernet1/0, Forward/Sparse-Dense, 00:05:10/00:03:04 (10.0.0.1, 239.1.2.3), 00:02:49/00:03:29, flags: T Incoming interface: GigabitEthernet0/0/0, RPF nbr 172.31.100.1 Outgoing interface list: GigabitEthernet1/0, Forward/Sparse-Dense, 00:02:49/00:03:04 (*, 224.0.1.39), 00:10:05/stopped, RP 0.0.0.0, flags: DC Incoming interface: Null, RPF nbr 0.0.0.0 Outgoing interface list: GigabitEthernet1/0, Forward/Sparse-Dense, 00:05:15/00:00:00 GigabitEthernet0/0, Forward/Sparse-Dense, 00:10:05/00:00:00 (172.16.0.1, 224.0.1.39), 00:02:00/00:01:33, flags: PTX Incoming interface: GigabitEthernet0/0/0, RPF nbr 172.31.100.1 </pre>	<p>Verifies that the mroute table is being populated properly on the last hop router.</p>
Step 5	<p>show ip interface [type number]</p> <p>Example:</p> <pre> Switch# show ip interface GigabitEthernet 0/0/0 GigabitEthernet0/0 is up, line protocol is up Internet address is 172.31.100.2/24 Broadcast address is 255.255.255.255 Address determined by setup command MTU is 1500 bytes Helper address is not set Directed broadcast forwarding is disabled Multicast reserved groups joined: 224.0.0.1 224.0.0.22 224.0.0.13 224.0.0.5 224.0.0.6 </pre>	<p>Verifies that multicast fast switching is enabled for optimal performance on the outgoing interface on the last hop router.</p> <p>Note Using the no ip mroute-cache interface command disables IP multicast fast-switching. When IP multicast fast switching is disabled, packets are forwarded through the process-switched path.</p>

	Command or Action	Purpose
	Outgoing access list is not set Inbound access list is not set Proxy ARP is enabled Local Proxy ARP is disabled Security level is default Split horizon is enabled ICMP redirects are always sent ICMP unreachable are always sent ICMP mask replies are never sent IP fast switching is enabled IP fast switching on the same interface is disabled IP Flow switching is disabled IP CEF switching is disabled IP Fast switching turbo vector IP multicast fast switching is enabled IP multicast distributed fast switching is disabled IP route-cache flags are Fast Router Discovery is disabled IP output packet accounting is disabled IP access violation accounting is disabled TCP/IP header compression is disabled RTP/IP header compression is disabled Policy routing is disabled Network address translation is disabled WCCP Redirect outbound is disabled WCCP Redirect inbound is disabled WCCP Redirect exclude is disabled BGP Policy Mapping is disabled	
Step 6	show ip pim interface count Example: Switch# show ip pim interface count State: * - Fast Switched, D - Distributed Fast Switched H - Hardware Switching Enabled Address Interface FS Mpackets In/Out 172.31.100.2 GigabitEthernet0/0/0 * 4122/0 10.1.0.1 GigabitEthernet1/0/0 * 0/3193	Confirms that multicast traffic is being forwarded on the last hop router.
Step 7	show ip mroute count Example: Switch# show ip mroute count IP Multicast Statistics 6 routes using 4008 bytes of memory 3 groups, 1.00 average sources per group Forwarding Counts: Pkt Count/Pkts per second/Avg Pkt Size/Kilobits per second Other counts: Total/RPF failed/Other drops(OIF-null, rate-limit etc) Group: 239.1.2.3, Source count: 1, Packets forwarded: 3165, Packets received: 3165 RP-tree: Forwarding: 0/0/0/0, Other: 0/0/0 Source: 10.0.0.1/32, Forwarding: 3165/20/28/4, Other: 0/0/0 Group: 224.0.1.39, Source count: 1, Packets forwarded: 21, Packets received: 120 Source: 172.16.0.1/32, Forwarding: 21/1/48/0, Other: 120/0/99 Group: 224.0.1.40, Source count: 1, Packets forwarded: 10, Packets received: 10	Confirms that multicast traffic is being forwarded on the last hop router.

	Command or Action	Purpose
	Source: 172.16.0.1/32, Forwarding: 10/1/48/0, Other: 10/0/0	
Step 8	<p>show ip mroute active [<i>kb/s</i>]</p> <p>Example: Switch# show ip mroute active Active IP Multicast Sources - sending >= 4 kbps</p> <p>Group: 239.1.2.3, (?) Source: 10.0.0.1 (?) Rate: 20 pps/4 kbps(1sec), 4 kbps(last 50 secs), 4 kbps(life avg)</p>	<p>Displays information about active multicast sources sending traffic to groups on the last hop router. The output of this command provides information about the multicast packet rate for active sources.</p> <p>Note By default, the output of the show ip mroute command with the active keyword displays information about active sources sending traffic to groups at a rate greater than or equal to 4 kb/s. To display information about active sources sending low-rate traffic to groups (that is, traffic less than 4 kb/s), specify a value of 1 for the <i>kb/s</i> argument. Specifying a value of 1 for this argument displays information about active sources sending traffic to groups at a rate equal to or greater than 1 kb/s, which effectively displays information about all possible active source traffic.</p>

Using PIM-Enabled Routers to Test IP Multicast Reachability

If all the PIM-enabled routers and access servers that you administer are members of a multicast group, pinging that group causes all routers to respond, which can be a useful administrative and debugging tool.

To use PIM-enabled routers to test IP multicast reachability, perform the following tasks:

Configuring Routers to Respond to Multicast Pings

Follow these steps to configure a router to respond to multicast pings. Perform the task on all the interfaces of a router and on all the routers participating in the multicast network:

SUMMARY STEPS

1. **enable**
2. **configure terminal**
3. **interface** *type number*
4. **ip igmp join-group** *group-address*
5. Repeat Step 3 and Step 4 for each interface on the router participating in the multicast network.
6. **end**

DETAILED STEPS

	Command or Action	Purpose
Step 1	enable Example: Switch> enable	Enables privileged EXEC mode. Enter your password if prompted.
Step 2	configure terminal Example: Switch# configure terminal	Enters global configuration mode.
Step 3	interface <i>type number</i> Example: Switch(config)# interface gigabitethernet 1/0/0	Enters interface configuration mode. For the <i>type</i> and <i>number</i> arguments, specify an interface that is directly connected to hosts or is facing hosts.
Step 4	ip igmp join-group <i>group-address</i> Example: Switch(config-if)# ip igmp join-group 225.2.2.2	(Optional) Configures an interface on the router to join the specified group. For the purpose of this task, configure the same group address for the <i>group-address</i> argument on all interfaces on the router participating in the multicast network. Note With this method, the router accepts the multicast packets in addition to forwarding them. Accepting the multicast packets prevents the router from fast switching.
Step 5	Repeat Step 3 and Step 4 for each interface on the router participating in the multicast network.	--
Step 6	end Example: Switch(config-if)# end	Ends the current configuration session and returns to privileged EXEC mode.

Pinging Routers Configured to Respond to Multicast Pings

Follow these steps on a router to initiate a ping test to the routers configured to respond to multicast pings. This task is used to test IP multicast reachability in a network.

SUMMARY STEPS

1. **enable**
2. **ping** *group-address*

DETAILED STEPS

	Command or Action	Purpose
Step 1	<p>enable</p> <p>Example:</p> <pre>Switch> enable</pre>	Enables privileged EXEC mode. Enter your password if prompted.
Step 2	<p>ping <i>group-address</i></p> <p>Example:</p> <pre>Switch# ping 225.2.2.2</pre>	<p>Pings an IP multicast group address.</p> <p>A successful response indicates that the group address is functioning.</p>

Monitoring and Troubleshooting PIM

Monitoring PIM Information

Use the privileged EXEC commands in the following table to monitor your PIM configurations.

Table 7: PIM Monitoring Commands

Command	Purpose
show ip pim interface	Displays information about interfaces configured for Protocol Independent Multicast (PIM).
show ip pim neighbor	Displays the PIM neighbor information.
show ip pim rp [<i>group-name</i> <i>group-address</i>]	Displays RP routers associated with a sparse-mode multicast group. This command is available in all software images.

Monitoring the RP Mapping and BSR Information

Use the privileged EXEC mode in the following table to verify the consistency of group-to-RP mappings:

Table 8: RP Mapping Monitoring Commands

Command	Purpose
<code>show ip pim rp-hash group</code>	Displays the RP that was selected for the specified group. That is, on a PIMv2 router or multilayer switch, confirms that the same RP is the one that a PIMv1 system chooses. For <i>group</i> , enter the group address for which to display RP information.

Use the privileged EXEC commands in the following table to monitor BSR information:

Table 9: BSR Monitoring Commands

Command	Purpose
<code>show ip pim bsr</code>	Displays information about the elected BSR.

Troubleshooting PIMv1 and PIMv2 Interoperability Problems

When debugging interoperability problems between PIMv1 and PIMv2, check these in the order shown:

- 1 Verify RP mapping with the `show ip pim rp-hash` privileged EXEC command, making sure that all systems agree on the same RP for the same group.
- 2 Verify interoperability between different versions of DRs and RPs. Make sure that the RPs are interacting with the DRs properly (by responding with register-stops and forwarding decapsulated data packets from registers).

Related Topics

[PIM Versions, on page 47](#)

Configuration Examples for PIM

Example: Enabling PIM Stub Routing

In this example, IP multicast routing is enabled, Switch A PIM uplink port 25 is configured as a routed uplink port with `sparse-dense-mode` enabled. PIM stub routing is enabled on the VLAN 100 interfaces and on Gigabit Ethernet port 20.

```
Switch(config)# ip multicast-routing distributed
Switch(config)# interface GigabitEthernet3/0/25
Switch(config-if)# no switchport
Switch(config-if)# ip address 3.1.1.2 255.255.255.0
Switch(config-if)# ip pim sparse-dense-mode
Switch(config-if)# exit
Switch(config)# interface vlan100
Switch(config-if)# ip pim passive
```

```
Switch(config-if)# exit
Switch(config)# interface GigabitEthernet3/0/20
Switch(config-if)# ip pim passive
Switch(config-if)# exit
Switch(config)# interface vlan100
Switch(config-if)# ip address 100.1.1.1 255.255.255.0
Switch(config-if)# ip pim passive
Switch(config-if)# exit
Switch(config)# interface GigabitEthernet3/0/20
Switch(config-if)# no switchport
Switch(config-if)# ip address 10.1.1.1 255.255.255.0
Switch(config-if)# ip pim passive
Switch(config-if)# end
```

Related Topics

[Enabling PIM Stub Routing](#) , on page 58

[PIM Stub Routing](#) , on page 47

Example: Verifying PIM Stub Routing

To verify that PIM stub is enabled for each interface, use the **show ip pim interface** privileged EXEC command:

```
Switch# show ip pim interface
Address Interface Ver/ Nbr Query DR DR
Mode Count Intvl Prior
3.1.1.2 GigabitEthernet3/0/25 v2/SD 1 30 1 3.1.1.2
100.1.1.1 Vlan100 v2/P 0 30 1 100.1.1.1
10.1.1.1 GigabitEthernet3/0/20 v2/P 0 30 1 10.1.1.1
```

Related Topics

[Enabling PIM Stub Routing](#) , on page 58

[PIM Stub Routing](#) , on page 47

Example: Manually Assigning an RP to Multicast Groups

This example shows how to configure the address of the RP to 147.106.6.22 for multicast group 225.2.2.2 only:

```
Switch(config)# access-list 1 permit 225.2.2.2 0.0.0.0
Switch(config)# ip pim rp-address 147.106.6.22 1
```

Related Topics

[Manually Assigning an RP to Multicast Groups](#) , on page 60

Example: Configuring Auto-RP

This example shows how to send RP announcements out all PIM-enabled interfaces for a maximum of 31 hops. The IP address of port 1 is the RP. Access list 5 describes the group for which this switch serves as RP:

```
Switch(config)# ip pim send-rp-announce gigabitethernet1/0/1 scope 31 group-list 5
Switch(config)# access-list 5 permit 224.0.0.0 15.255.255.255
```

Related Topics

[Setting Up Auto-RP in a New Internetwork](#) , on page 62

[Auto-RP](#) , on page 49

Example: Defining the IP Multicast Boundary to Deny Auto-RP Information

This example shows a portion of an IP multicast boundary configuration that denies Auto-RP information:

```
Switch(config)# access-list 1 deny 224.0.1.39
Switch(config)# access-list 1 deny 224.0.1.40
Switch(config)# access-list 1 permit all
Switch(config)# interface gigabitethernet1/0/1
Switch(config-if)# ip multicast boundary 1
```

Related Topics

[Defining the IP Multicast Boundary](#) , on page 75

Example: Filtering Incoming RP Announcement Messages

This example shows a sample configuration on an Auto-RP mapping agent that is used to prevent candidate RP announcements from being accepted from unauthorized candidate RPs:

```
Switch(config)# ip pim rp-announce-filter rp-list 10 group-list 20
Switch(config)# access-list 10 permit host 172.16.5.1
Switch(config)# access-list 10 permit host 172.16.2.1
Switch(config)# access-list 20 deny 239.0.0.0 0.0.255.255
Switch(config)# access-list 20 permit 224.0.0.0 15.255.255.255
```

The mapping agent accepts candidate RP announcements from only two devices, 172.16.5.1 and 172.16.2.1. The mapping agent accepts candidate RP announcements from these two devices only for multicast groups that fall in the group range of 224.0.0.0 to 239.255.255.255. The mapping agent does not accept candidate RP announcements from any other devices in the network. Furthermore, the mapping agent does not accept candidate RP announcements from 172.16.5.1 or 172.16.2.1 if the announcements are for any groups in the 239.0.0.0 through 239.255.255.255 range. This range is the administratively scoped address range.

Related Topics

[Filtering Incoming RP Announcement Messages](#) , on page 71

Example: Preventing Join Messages to False RPs

If all interfaces are in sparse mode, use a default-configured RP to support the two well-known groups 224.0.1.39 and 224.0.1.40. Auto-RP uses these two well-known groups to collect and distribute RP-mapping information. When this is the case and the **ip pim accept-rp auto-rp** command is configured, another **ip pim accept-rp** command accepting the RP must be configured as follows:

```
Switch(config)# ip pim accept-rp 172.10.20.1 1
Switch(config)# access-list 1 permit 224.0.1.39
Switch(config)# access-list 1 permit 224.0.1.40
```

Related Topics

[Preventing Join Messages to False RPs](#) , on page 70

Example: Configuring Candidate BSRs

This example shows how to configure a candidate BSR, which uses the IP address 172.21.24.18 on a port as the advertised BSR address, uses 30 bits as the hash-mask-length, and has a priority of 10.

```
Switch(config)# interface gigabitethernet1/0/2
Switch(config-if)# ip address 172.21.24.18 255.255.255.0
Switch(config-if)# ip pim sparse-dense-mode
Switch(config-if)# ip pim bsr-candidate gigabitethernet1/0/2 30 10
```

Related Topics

[Configuring Candidate BSRs](#) , on page 78

[Bootstrap Router](#) , on page 50

Example: Configuring Candidate RPs

This example shows how to configure the switch to advertise itself as a candidate RP to the BSR in its PIM domain. Standard access list number 4 specifies the group prefix associated with the RP that has the address identified by a port. That RP is responsible for the groups with the prefix 239.

```
Switch(config)# ip pim rp-candidate gigabitethernet1/0/2 group-list 4
Switch(config)# access-list 4 permit 239.0.0.0 0.255.255.255
```

Related Topics

[Configuring the Candidate RPs](#) , on page 79

Additional References

Related Documents

Related Topic	Document Title
For complete syntax and usage information for the commands used in this chapter.	<i>Command Reference, Cisco Release 15.2(2)E (Industrial Ethernet 3000 Switch)</i>
Configuring EIGRP	<i>Software Configuration Guide, Cisco IOS Release 15.2(2)E (Industrial Ethernet 3000 Switch)</i>
Cisco IOS commands	Cisco IOS Master Commands List, All Releases
Cisco IOS IP SLAs commands	Cisco IOS IP Multicast Command Reference

Error Message Decoder

Description	Link
To help you research and resolve system error messages in this release, use the Error Message Decoder tool.	https://www.cisco.com/cgi-bin/Support/Errordecoder/index.cgi

Standards and RFCs

Standard/RFC	Title
PIM is defined in RFC 4601 and in these Internet Engineering Task Force (IETF) Internet drafts.	<ul style="list-style-type: none"> • <i>Protocol Independent Multicast (PIM): Motivation and Architecture</i> • <i>Protocol Independent Multicast (PIM), Dense Mode Protocol Specification</i> • <i>Protocol Independent Multicast (PIM), Sparse Mode Protocol Specification</i> • <i>draft-ietf-idmr-igmp-v2-06.txt, Internet Group Management Protocol, Version 2</i> • <i>draft-ietf-pim-v2-dm-03.txt, PIM Version 2 Dense Mode</i>

MIBs

MIB	MIBs Link
All supported MIBs for this release.	To locate and download MIBs for selected platforms, Cisco IOS releases, and feature sets, use Cisco MIB Locator found at the following URL: http://www.cisco.com/go/mibs

Technical Assistance

Description	Link
<p>The Cisco Support website provides extensive online resources, including documentation and tools for troubleshooting and resolving technical issues with Cisco products and technologies.</p> <p>To receive security and technical information about your products, you can subscribe to various services, such as the Product Alert Tool (accessed from Field Notices), the Cisco Technical Services Newsletter, and Really Simple Syndication (RSS) Feeds.</p> <p>Access to most tools on the Cisco Support website requires a Cisco.com user ID and password.</p>	http://www.cisco.com/support



Configuring HSRP Aware PIM

- [HSRP Aware PIM](#), page 101

HSRP Aware PIM

This module describes how to configure the HSRP Aware PIM feature for enabling multicast traffic to be forwarded through the Hot Standby Router Protocol (HSRP) active router (AR), allowing Protocol Independent Multicast (PIM) to leverage HSRP redundancy, avoid potential duplicate traffic, and enable failover.

Finding Feature Information

Your software release may not support all the features documented in this module. For the latest caveats and feature information, see [Bug Search Tool](#) and the release notes for your platform and software release. To find information about the features documented in this module, and to see a list of the releases in which each feature is supported, see the feature information table at the end of this module.

Use Cisco Feature Navigator to find information about platform support and Cisco software image support. To access Cisco Feature Navigator, go to www.cisco.com/go/cfn. An account on Cisco.com is not required.

Restrictions for HSRP Aware PIM

- HSRP IPv6 is not supported.
- Stateful failover is not supported. During PIM stateless failover, the HSRP group's virtual IP address transfers to the standby router but no mrouting state information is transferred. PIM listens and responds to state change events and creates mroute states upon failover.
- The maximum number of HSRP groups that can be tracked by PIM on each interface is 16.
- The redundancy priority for a PIM DR must be greater than the configured or default value (1) of the PIM DR priority on any device for which the same HSRP group is enabled or the HSRP Active will fail to win the DR election.

Information About HSRP Aware PIM

HSRP

Hot Standby Router Protocol (HSRP) is a Cisco proprietary redundancy protocol for establishing a fault-tolerant default gateway.

The protocol establishes a framework between network devices in order to achieve default gateway failover if the primary gateway becomes inaccessible. By sharing an IP address and a MAC (Layer 2) address, two or more devices can act as a single virtual router. The members of a virtual router group continually exchange status messages and one device can assume the routing responsibility of another, should it go out of commission for either planned or unplanned reasons. Hosts continue to forward IP packets to a consistent IP and MAC address, and the changeover of devices doing the routing is transparent.

HSRP is useful for hosts that do not support a router discovery protocol and cannot switch to a new device when their selected device reloads or loses power. Because existing TCP sessions can survive the failover, this protocol also provides a more transparent recovery for hosts that dynamically choose a next hop for routing IP traffic.

When HSRP is configured on a network segment, it provides a virtual MAC address and an IP address that is shared among a group of devices running HSRP. The address of this HSRP group is referred to as the virtual IP address. One of these devices is selected by the protocol to be the active router (AR). The AR receives and routes packets destined for the MAC address of the group.

HSRP uses a priority mechanism to determine which HSRP configured device is to be the default AR. To configure a device as the AR, you assign it a priority that is higher than the priority of all the other HSRP-configured devices. The default priority is 100, so if you configure just one device to have a higher priority, that device will be the default AR.

Devices that are running HSRP send and receive multicast User Datagram Protocol (UDP)-based hello messages to detect device failure and to designate active and standby devices. When the AR fails to send a hello message within a configurable period of time, the standby device with the highest priority becomes the AR. The transition of packet forwarding functions between devices is completely transparent to all hosts on the network.

You can configure multiple Hot Standby groups on an interface, thereby making fuller use of redundant devices and load sharing.

HSRP is not a routing protocol as it does not advertise IP routes or affect the routing table in any way.

HSRP has the ability to trigger a failover if one or more interfaces on the device fail. This can be useful for dual branch devices each with a single serial link back to the head end. If the serial link of the primary device goes down, the backup device takes over the primary functionality and thus retains connectivity to the head end.

HSRP Aware PIM

Protocol Independent Multicast (PIM) has no inherent redundancy capabilities and its operation is completely independent of Hot Standby Router Protocol (HSRP) group states. As a result, IP multicast traffic is forwarded not necessarily by the same device as is elected by HSRP. The HSRP Aware PIM feature provides consistent IP multicast forwarding in a redundant network with virtual routing groups enabled.

HSRP Aware PIM enables multicast traffic to be forwarded through the HSRP active router (AR), allowing PIM to leverage HSRP redundancy, avoid potential duplicate traffic, and enable failover, depending on the

HSRP states in the device. The PIM designated router (DR) runs on the same gateway as the HSRP AR and maintains mroute states.

In a multiaccess segment (such as LAN), PIM DR election is unaware of the redundancy configuration, and the elected DR and HSRP AR may not be the same router. In order to ensure that the PIM DR is always able to forward PIM Join/Prune message towards RP or FHR, the HSRP AR becomes the PIM DR (if there is only one HSRP group). PIM is responsible for adjusting DR priority based on the group state. When a failover occurs, multicast states are created on the new AR elected by the HSRP group and the AR assumes responsibility for the routing and forwarding of all the traffic addressed to the HSRP virtual IP address.

With HSRP Aware PIM enabled, PIM sends an additional PIM Hello message using the HSRP virtual IP addresses as the source address for each active HSRP group when a device becomes HSRP Active. The PIM Hello will carry a new GenID in order to trigger other routers to respond to the failover. When a downstream device receives this PIM Hello, it will add the virtual address to its PIM neighbor list. The new GenID carried in the PIM Hello will trigger downstream routers to resend PIM Join messages towards the virtual address. Upstream routers will process PIM Join/Prunes (J/P) based on HSRP group state.

If the J/P destination matches the HSRP group virtual address and if the destination device is in HSRP active state, the new AR processes the PIM Join because it is now the acting PIM DR. This allows all PIM Join/Prunes to reach the HSRP group virtual address and minimizes changes and configurations at the downstream routers side.

The IP routing service utilizes the existing virtual routing protocol to provide basic stateless failover services to client applications, such as PIM. Changes in the local HSRP group state and standby router responsibility are communicated to interested client applications. Client applications may build on top of IRS to provide stateful or stateless failover. PIM, as an HSRP client, listens to the state change notifications from HSRP and automatically adjusts the priority of the PIM DR based on the HSRP state. The PIM client also triggers communication between upstream and downstream devices upon failover in order to create an mroute state on the new AR.

How to Configure HSRP Aware PIM

Configuring an HSRP Group on an Interface

Before You Begin

- IP multicast must already be configured on the device.
- PIM must already be configured on the interface.

SUMMARY STEPS

1. **enable**
2. **configure terminal**
3. **interface** *type number* [*name-tag*]
4. **ip address** *ip-address mask*
5. **standby** [*group-number*] **ip** [*ip-address* [*secondary*]]
6. **standby** [*group-number*] **timers** [*msec*] *hellotime* [*msec*] *holdtime*
7. **standby** [*group-number*] **priority** *priority*
8. **standby** [*group-number*] **name** *group-name*
9. **end**
10. **show standby** [*type number* [*group*]] [**all** | **brief**]

DETAILED STEPS

	Command or Action	Purpose
Step 1	enable Example: Device> enable	Enables privileged EXEC mode. • Enter your password if prompted.
Step 2	configure terminal Example: Device# configure terminal	Enters global configuration mode.
Step 3	interface <i>type number</i> [<i>name-tag</i>] Example: Device(config)# interface ethernet 0/0	Specifies an interface to be configured and enters interface configuration mode.
Step 4	ip address <i>ip-address mask</i> Example: Device(config-if)# ip address 10.0.0.2 255.255.255.0	Sets a primary or secondary IP address for an interface.
Step 5	standby [<i>group-number</i>] ip [<i>ip-address</i> [<i>secondary</i>]] Example: Device(config-if)# standby 1 ip 192.0.2.99	Activates HSRP and defines an HSRP group.
Step 6	standby [<i>group-number</i>] timers [<i>msec</i>] <i>hellotime</i> [<i>msec</i>] <i>holdtime</i> Example: Device(config-if)# standby 1 timers 5 15	(Optional) Configures the time between hello packets and the time before other devices declare an HSRP active or standby router to be down.

	Command or Action	Purpose
Step 7	standby [<i>group-number</i>] priority <i>priority</i> Example: Device(config-if)# standby 1 priority 120	(Optional) Assigns the HSRP priority to be used to help select the HSRP active and standby routers.
Step 8	standby [<i>group-number</i>] name <i>group-name</i> Example: Device(config-if)# standby 1 name HSRP1	(Optional) Defines a name for the HSRP group. Note We recommend that you always configure the standby ip name command when configuring an HSRP group to be used for HSRP Aware PIM.
Step 9	end Example: Device(config-if)# end	Returns to privileged EXEC mode.
Step 10	show standby [<i>type number</i> [<i>group</i>]] [all brief] Example: Device# show standby	Displays HSRP group information for verifying the configuration.

Configuring PIM Redundancy

Before You Begin

The HSRP group must already be configured on the interface. See the “Configuring an HSRP Group on an Interface” section.

SUMMARY STEPS

1. **enable**
2. **configure terminal**
3. **interface** *type number* [*name-tag*]
4. **ip address** *ip-address mask*
5. **ip pim redundancy group** *dr-priority priority*
6. **end**

DETAILED STEPS

	Command or Action	Purpose
Step 1	enable Example: Device> enable	Enables privileged EXEC mode. <ul style="list-style-type: none"> • Enter your password if prompted.

	Command or Action	Purpose
Step 2	configure terminal Example: Device# configure terminal	Enters global configuration mode.
Step 3	interface <i>type number</i> [<i>name-tag</i>] Example: Device(config)# interface ethernet 0/0	Specifies an interface to be configured and enters interface configuration mode.
Step 4	ip address <i>ip-address mask</i> Example: Device(config-if)# ip address 10.0.0.2 255.255.255.0	Sets a primary or secondary IP address for an interface.
Step 5	ip pim redundancy <i>group dr-priority priority</i> Example: Device(config-if)# ip pim redundancy HSRP1 dr-priority 60	Enables PIM redundancy and assigns a redundancy priority value to the active PIM designated router (DR). <ul style="list-style-type: none"> • Because HSRP group names are case sensitive, the value of the <i>group</i> argument must match the group name configured by using the standby ip name command. • The redundancy priority for a PIM DR must be greater than the configured or default value (1) of the PIM DR priority on any device for which the same HSRP group is enabled.
Step 6	end Example: Device(config-if)# end	Returns to privileged EXEC mode.

Configuration Examples for HSRP Aware PIM

Example: Configuring an HSRP Group on an Interface

```
interface ethernet 0/0
 ip address 10.0.0.2 255.255.255.0
 standby 1 ip 192.0.2.99
 standby 1 timers 5 15
 standby 1 priority 120
 standby 1 name HSRP1
 !
!
```

Example: Configuring PIM Redundancy

```
interface ethernet 0/0
 ip address 10.0.0.2 255.255.255.0
 ip pim redundancy HSRP1 dr-priority 60
!
```

Additional References for HSRP Aware PIM

Related Documents

Related Topic	Document Title
Cisco IOS commands	Cisco IOS Master Commands List, All Releases
IP multicast commands	Cisco IOS IP Multicast Command Reference
HSRP commands	First Hop Redundancy Protocol Command Reference

Standards and RFCs

Standard/RFC	Title
RFC 2281	<i>Cisco Hot Standby Router Protocol (HSRP)</i>

MIBs

MIB	MIBs Link
No new or modified MIBs are supported by this feature, and support for existing MIBs has not been modified by this feature.	To locate and download MIBs for selected platforms, Cisco software releases, and feature sets, use Cisco MIB Locator found at the following URL: http://www.cisco.com/go/mibs

Technical Assistance

Description	Link
The Cisco Support and Documentation website provides online resources to download documentation, software, and tools. Use these resources to install and configure the software and to troubleshoot and resolve technical issues with Cisco products and technologies. Access to most tools on the Cisco Support and Documentation website requires a Cisco.com user ID and password.	http://www.cisco.com/cisco/web/support/index.html

Feature Information for HSRP Aware PIM

The following table provides release information about the feature or features described in this module. This table lists only the software release that introduced support for a given feature in a given software release train. Unless noted otherwise, subsequent releases of that software release train also support that feature.

Use Cisco Feature Navigator to find information about platform support and Cisco software image support. To access Cisco Feature Navigator, go to www.cisco.com/go/cfn. An account on Cisco.com is not required.

Table 10: Feature Information for HSRP Aware PIM

Feature Name	Releases	Feature Information
HSRP Aware PIM	15.2(4)S 15.3(1)T 15.3(1)SY1 15.2(1)E	The HSRP Aware PIM feature provides consistent IP multicast forwarding in a redundant network with virtual routing groups by enabling multicast traffic to be forwarded through a Hot Standby Router Protocol (HSRP) active router, allowing PIM to leverage HSRP redundancy, avoid potential duplicate traffic, and enable failover, depending on the HSRP states in the device.



Configuring VRRP Aware PIM

- [VRRP Aware PIM, page 109](#)

VRRP Aware PIM

The Virtual Router Redundancy Protocol (VRRP) eliminates the single point of failure inherent in the static default routed environment. VRRP is an election protocol that dynamically assigns responsibility for one or more virtual routers to the VRRP routers on a LAN, allowing several routers on a multi access link to utilize the same virtual IP address.

VRRP Aware PIM is a redundancy mechanism for the Protocol Independent Multicast (PIM) to interoperate with VRRP. It allows PIM to track VRRP state and to preserve multicast traffic upon fail over in a redundant network with virtual routing groups enabled.

This module explains how to configure VRRP Aware PIM in a network.

Finding Feature Information

Your software release may not support all the features documented in this module. For the latest caveats and feature information, see [Bug Search Tool](#) and the release notes for your platform and software release. To find information about the features documented in this module, and to see a list of the releases in which each feature is supported, see the feature information table at the end of this module.

Use Cisco Feature Navigator to find information about platform support and Cisco software image support. To access Cisco Feature Navigator, go to www.cisco.com/go/cfn. An account on Cisco.com is not required.

Restrictions for VRRP Aware PIM

- Only PIM sparse mode (SM) and source specific multicast (SSM) modes are supported. Bidirectional (BiDir) PIM is not supported.
- PIM interoperability with Hot Standby Router Protocol (HSRP) IPv6 is not supported.
- PIM tracks only one virtual group, either Virtual Router Redundancy Protocol (VRRP) or HSRP, per interface.

- VRRP Aware PIM is not supported on a Transit network. PIM redundancy enabled interface does not support the PIM joining the network from down stream.

Information About VRRP Aware PIM

Overview of VRRP Aware PIM

Virtual Router Redundancy Protocol (VRRP) is a redundancy protocol for establishing a fault-tolerant default gateway. The protocol establishes a framework between network devices in order to achieve default gateway failover if the primary gateway becomes inaccessible.

Protocol Independent Multicast (PIM) has no inherent redundancy capabilities and its operation is completely independent of VRRP group states. As a result, IP multicast traffic is forwarded not necessarily by the same device as is elected by VRRP. The VRRP Aware PIM feature provides consistent IP multicast forwarding in a redundant network with virtual routing groups enabled.

In a multi-access segment (such as LAN), PIM designated router (DR) election is unaware of the redundancy configuration, and the elected DR and VRRP master router (MR) may not be the same router. In order to ensure that the PIM DR is always able to forward PIM Join/Prune message towards RP or FHR, the VRRP MR becomes the PIM DR (if there is only one VRRP group). PIM is responsible for adjusting DR priority based on the group state. When a fail over occurs, multicast states are created on the new MR elected by the VRRP group and the MR assumes responsibility for the routing and forwarding of all the traffic addressed to the VRRP virtual IP address. This ensures the PIM DR runs on the same gateway as the VRRP MR and maintains mroute states. It enables multicast traffic to be forwarded through the VRRP MR, allowing PIM to leverage VRRP redundancy, avoid potential duplicate traffic, and enable fail over, depending on the VRRP states in the device.

Virtual Router Redundancy Service (VRRS) provides public APIs for a client to communicate with VRRP. VRRP Aware PIM is a feature of VRRS that supports VRRPv3 (unified VRRP) in both IPv4 and IPv6.

PIM, as a VRRS client, uses the VRRS client API to obtain generic First Hop Redundancy Protocol (FHRP) state and configuration information in order to provide multicast redundancy functionalities.

PIM performs the following as a VRRS client:

- Listens to state change and update notification from VRRS server (i.e., VRRP).
- Automatically adjust PIM DR priority based on VRRP state.
- Upon VRRP fail over, PIM receives state change notification from VRRS for the tracked VRRP group and ensures traffic is forwarded through VRRP MR.

How to Configure VRRP Aware PIM

Configuring VRRP Aware PIM

SUMMARY STEPS

1. **enable**
2. **configure terminal**
3. **fhrp version vrrp *version***
4. **interface *type number***
5. **ip address *address***
6. **vrrp *group id* address-family ipv4**
7. **vrrs leader *group name***
8. **vrrp *group id* ip *ip address***
9. **exit**
10. **interface *type number***
11. **ip pim redundancy *group name* vrrp dr-priority *priority-value***
12. **end**

DETAILED STEPS

	Command or Action	Purpose
Step 1	enable Example: Device> enable	Enables privileged EXEC mode. <ul style="list-style-type: none"> • Enter your password if prompted.
Step 2	configure terminal Example: Router# configure terminal	Enters global configuration mode.
Step 3	fhrp version vrrp <i>version</i> Example: Device(config)# fhrp version vrrp v3	Enables the ability to configure VRRPv3 and VRRS.
Step 4	interface <i>type number</i> Example: Device(config)# interface Ethernet0/0	Specifies an interface to be configured and enters interface configuration mode.

	Command or Action	Purpose
Step 5	ip address <i>address</i> Example: Device(config-if)# ip address 192.0.2.2	Specifies a primary or secondary address for the VRRP group.
Step 6	vrrp group id address-family ipv4 Example: Device(config-if)# vrrp 1 address-family ipv4	Creates a VRRP group and enters VRRP configuration mode.
Step 7	vrrs leader group name Example: Device(config-if-vrrp)# vrrs leader VRRP1	Enables community and (or) extended community exchange with the specified neighbor.
Step 8	vrrp group id ip ip address Example: Device(config-if-vrrp)# vrrp 1 ip 10.1.6.1	Exits address family configuration mode and returns to router configuration mode.
Step 9	exit Example: Device(config-if-vrrp)# exit	Exits VRRP configuration mode and returns to global configuration mode.
Step 10	interface type number Example: Device(config)# interface Ethernet0/0	Specifies an interface to be configured and enters interface configuration mode.
Step 11	ip pim redundancy group name vrrp dr-priority priority-value Example: Device(config-if)# ip pim redundancy VRRP1 vrrp dr-priority 90	sets the priority for which a router is elected as the designated router (DR). <ul style="list-style-type: none"> • The redundancy dr-priority value should be same on all routers that are enabled with VRRP Aware PIM feature.
Step 12	end Example: Device(config-if)# end	Exits interface configuration mode and returns to privileged EXEC mode.

Configuration Examples for VRRP Aware PIM

Example: VRRP Aware PIM

```

conf terminal
  fhrp version vrrp v3
  interface Ethernet0/0
    ip address 192.0.2.2
    vrrp 1 address-family ipv4

  vrrp 1 ip 10.1.6.1

  vrrs leader VRRP1
  interface Ethernet0/0
    ip pim redundancy VRRP1 vrrp dr-priority 90
  !

```

Additional References for VRRP Aware PIM

Related Documents

Related Topic	Document Title
Cisco IOS commands	Cisco IOS Master Commands List, All Releases
IP multicast commands	Cisco IOS IP Multicast Command Reference
Configuring VRRP	First Hop Redundancy Protocols Configuration Guide
IP multicast PIM	IP Multicast: PIM Configuration Guide

Technical Assistance

Description	Link
<p>The Cisco Support and Documentation website provides online resources to download documentation, software, and tools. Use these resources to install and configure the software and to troubleshoot and resolve technical issues with Cisco products and technologies. Access to most tools on the Cisco Support and Documentation website requires a Cisco.com user ID and password.</p>	<p>http://www.cisco.com/cisco/web/support/index.html</p>



Configuring Basic IP Multicast Routing

- [Finding Feature Information, page 115](#)
- [Prerequisites for Basic IP Multicast Routing, page 115](#)
- [Restrictions for Basic IP Multicast Routing, page 116](#)
- [Information About Basic IP Multicast Routing, page 116](#)
- [How to Configure Basic IP Multicast Routing, page 118](#)
- [Monitoring and Maintaining Basic IP Multicast Routing, page 126](#)
- [Additional References, page 129](#)

Finding Feature Information

Your software release may not support all the features documented in this module. For the latest caveats and feature information, see [Bug Search Tool](#) and the release notes for your platform and software release. To find information about the features documented in this module, and to see a list of the releases in which each feature is supported, see the feature information table at the end of this module.

Use Cisco Feature Navigator to find information about platform support and Cisco software image support. To access Cisco Feature Navigator, go to www.cisco.com/go/cfn. An account on Cisco.com is not required.

Prerequisites for Basic IP Multicast Routing

The following are the prerequisites for configuring basic IP multicast routing:

- To use this feature, the switch must be running the IP services feature set. The IP Services image contains complete multicast routing.
- You must configure the PIM version and the PIM mode in order to perform IP multicast routing. The switch populates its multicast routing table and forwards multicast packets it receives from its directly connected LANs according to the mode setting. You can configure an interface to be in the PIM dense mode, sparse mode, or sparse-dense mode.

On a switch running the IP base image, if you try to configure a VLAN interface with PIM dense-mode, sparse-mode, or dense-sparse-mode, the configuration is not allowed.

- Enabling PIM on an interface also enables IGMP operation on that interface. (To participate in IP multicasting, the multicast hosts, routers, and multilayer device must have IGMP operating.)

If you enable PIM on multiple interfaces, when most of these interfaces are not on the outgoing interface list, and IGMP snooping is disabled, the outgoing interface might not be able to sustain line rate for multicast traffic because of the extra replication.

Related Topics

[Configuring Basic IP Multicast Routing](#), on page 118

[Information About Basic IP Multicast Routing](#), on page 116

Restrictions for Basic IP Multicast Routing

The following are the restrictions for IP multicast routing:

- IP multicast routing is not supported on switches running the LAN base feature set.

Information About Basic IP Multicast Routing

IP multicasting is an efficient way to use network resources, especially for bandwidth-intensive services such as audio and video. IP multicast routing enables a host (source) to send packets to a group of hosts (receivers) anywhere within the IP network by using a special form of IP address called the IP multicast group address.

The sending host inserts the multicast group address into the IP destination address field of the packet, and IP multicast routers and multilayer switches forward incoming IP multicast packets out all interfaces that lead to members of the multicast group. Any host, regardless of whether it is a member of a group, can send to a group. However, only the members of a group receive the message.

Related Topics

[Configuring Basic IP Multicast Routing](#), on page 118

[Default IP Multicast Routing Configuration](#), on page 117

[Prerequisites for Basic IP Multicast Routing](#), on page 115

Multicast Routing and Switch Stacks

For all multicast routing protocols, the entire stack appears as a single router to the network and operates as a single multicast router.

In a switch stack, the active switch performs these functions:

- It is responsible for completing the IP multicast routing functions of the stack. It fully initializes and runs the IP multicast routing protocols.
- It builds and maintains the multicast routing table for the entire stack.
- It is responsible for distributing the multicast routing table to all stack members.

The stack members perform these functions:

- They act as multicast routing standby devices and are ready to take over if there is a active switch failure. If the active switch fails, all stack members delete their multicast routing tables. The newly elected active switch starts building the routing tables and distributes them to the stack members.
- They do not build multicast routing tables. Instead, they use the multicast routing table that is distributed by the active switch.

Default IP Multicast Routing Configuration

This table displays the default IP multicast routing configuration.

Table 11: Default IP Multicast Routing Configuration

Feature	Default Setting
Multicast routing	Disabled on all interfaces.
PIM version	Version 2.
PIM mode	No mode is defined.
PIM stub routing	None configured.
PIM RP address	None configured.
PIM domain border	Disabled.
PIM multicast boundary	None.
Candidate BSRs	Disabled.
Candidate RPs	Disabled.
Shortest-path tree threshold rate	0 kb/s.
PIM router query message interval	30 seconds.

Related Topics

[Configuring Basic IP Multicast Routing](#), on page 118

[Information About Basic IP Multicast Routing](#), on page 116

sdr Listener Support

The MBONE is the small subset of Internet routers and hosts that are interconnected and capable of forwarding IP multicast traffic. Other multimedia content is often broadcast over the MBONE. Before you can join a multimedia session, you need to know what multicast group address and port are being used for the session,

when the session is going to be active, and what sort of applications (audio, video, and so forth) are required on your workstation. The MBONE Session Directory Version 2 (sdr) tool provides this information. This freeware application can be downloaded from several sites on the World Wide Web, one of which is <http://www.video.ja.net/mice/index.html>.

SDR is a multicast application that listens to a well-known multicast group address and port for Session Announcement Protocol (SAP) multicast packets from SAP clients, which announce their conference sessions. These SAP packets contain a session description, the time the session is active, its IP multicast group addresses, media format, contact person, and other information about the advertised multimedia session. The information in the SAP packet is displayed in the SDR Session Announcement window.

How to Configure Basic IP Multicast Routing

Configuring Basic IP Multicast Routing

By default, multicast routing is disabled, and there is no default mode setting.

This procedure is required.

Before You Begin

You must configure the PIM version and the PIM mode. The switch populates its multicast routing table and forwards multicast packets it receives from its directly connected LANs according to the mode setting.

In populating the multicast routing table, dense-mode interfaces are always added to the table. Sparse-mode interfaces are added to the table only when periodic join messages are received from downstream devices or when there is a directly connected member on the interface. When forwarding from a LAN, sparse-mode operation occurs if there is an RP known for the group. If so, the packets are encapsulated and sent toward the RP. When no RP is known, the packet is flooded in a dense-mode fashion. If the multicast traffic from a specific source is sufficient, the receiver's first-hop router might send join messages toward the source to build a source-based distribution tree.

SUMMARY STEPS

1. **enable**
2. **configure terminal**
3. **ip multicast-routing distributed**
4. **interface *interface-id***
5. **ip pim version [1 | 2]**
6. **ip pim {dense-mode | sparse-mode | sparse-dense-mode}**
7. **end**
8. **show running-config**
9. **copy running-config startup-config**

DETAILED STEPS

	Command or Action	Purpose
Step 1	<p>enable</p> <p>Example:</p> <pre>Switch> enable</pre>	<p>Enables privileged EXEC mode.</p> <ul style="list-style-type: none"> • Enter your password if prompted.
Step 2	<p>configure terminal</p> <p>Example:</p> <pre>Switch# configure terminal</pre>	<p>Enters the global configuration mode.</p>
Step 3	<p>ip multicast-routing distributed</p> <p>Example:</p> <pre>Switch(config)# ip multicast-routing distributed</pre>	<p>Enables IP multicast distributed switching</p> <p>Note To disable multicasting, use the no ip multicast-routing distributed global configuration command.</p>
Step 4	<p>interface <i>interface-id</i></p> <p>Example:</p> <pre>Switch(config)# interface gigabitethernet 1/0/1</pre>	<p>Specifies the Layer 3 interface on which you want to enable multicast routing, and enters interface configuration mode.</p> <p>The specified interface must be one of the following:</p> <ul style="list-style-type: none"> • A routed port—A physical port that has been configured as a Layer 3 port by entering the no switchport interface configuration command. You will also need to enable IP PIM sparse-dense-mode on the interface, and join the interface as a statically connected member to an IGMP static group. For a configuration example, see Example: Interface Configuration as a Routed Port • An SVI—A VLAN interface created by using the interface vlan <i>vlan-id</i> global configuration command. You will also need to enable IP PIM sparse-dense-mode on the VLAN, join the VLAN as a statically connected member to an IGMP static group, and then enable IGMP snooping on the VLAN, the IGMP static group, and physical interface. For a configuration example, see Example: Interface Configuration as an SVI <p>These interfaces must have IP addresses assigned to them.</p>
Step 5	<p>ip pim version [1 2]</p> <p>Example:</p> <pre>Switch(config-if)# ip pim version 2</pre>	<p>Configures the PIM version on the interface.</p> <p>By default, Version 2 is enabled and is the recommended setting.</p> <p>An interface in PIMv2 mode automatically downgrades to PIMv1 mode if that interface has a PIMv1 neighbor. The interface returns to Version 2 mode after all Version 1 neighbors are shut down or upgraded.</p> <p>Note To return to the default PIM version, use the no ip pim version interface configuration command.</p>

	Command or Action	Purpose
Step 6	<p>ip pim {dense-mode sparse-mode sparse-dense-mode}</p> <p>Example:</p> <pre>Switch(config-if)# ip pim sparse-dense-mode</pre>	<p>Enables a PIM mode on the interface.</p> <p>By default, no mode is configured.</p> <p>The keywords have these meanings:</p> <ul style="list-style-type: none"> • dense-mode—Enables dense mode of operation. • sparse-mode—Enables sparse mode of operation. If you configure sparse mode, you must also configure an RP. • sparse-dense-mode—Causes the interface to be treated in the mode in which the group belongs. Sparse-dense mode is the recommended setting. <p>Note To disable PIM on an interface, use the no ip pim interface configuration command.</p>
Step 7	<p>end</p> <p>Example:</p> <pre>Switch(config-if)# end</pre>	Returns to privileged EXEC mode.
Step 8	<p>show running-config</p> <p>Example:</p> <pre>Switch# show running-config</pre>	Verifies your entries.
Step 9	<p>copy running-config startup-config</p> <p>Example:</p> <pre>Switch# copy running-config startup-config</pre>	(Optional) Saves your entries in the configuration file.

Related Topics

[Information About Basic IP Multicast Routing](#), on page 116

[Default IP Multicast Routing Configuration](#), on page 117

[Prerequisites for Basic IP Multicast Routing](#), on page 115

Configuring Optional IP Multicast Routing Features

Defining the IP Multicast Boundary

You define a multicast boundary to prevent Auto-RP messages from entering the PIM domain. You create an access list to deny packets destined for 224.0.1.39 and 224.0.1.40, which carry Auto-RP information.

This procedure is optional.

SUMMARY STEPS

1. **enable**
2. **configure terminal**
3. **access-list** *access-list-number* **deny** *source* [*source-wildcard*]
4. **interface** *interface-id*
5. **ip multicast boundary** *access-list-number*
6. **end**
7. **show running-config**
8. **copy running-config startup-config**

DETAILED STEPS

	Command or Action	Purpose
Step 1	enable Example: Switch> enable	Enables privileged EXEC mode. Enter your password if prompted.
Step 2	configure terminal Example: Switch# configure terminal	Enters the global configuration mode.
Step 3	access-list <i>access-list-number</i> deny <i>source</i> [<i>source-wildcard</i>] Example: Switch(config)# access-list 12 deny 224.0.1.39 access-list 12 deny 224.0.1.40	Creates a standard access list, repeating the command as many times as necessary. <ul style="list-style-type: none"> • For <i>access-list-number</i>, the range is 1 to 99. • The deny keyword denies access if the conditions are matched. • For <i>source</i>, enter multicast addresses 224.0.1.39 and 224.0.1.40, which carry Auto-RP information. • (Optional) For <i>source-wildcard</i>, enter the wildcard bits in dotted decimal notation to be applied to the source. Place ones in the bit positions that you want to ignore.

	Command or Action	Purpose
		The access list is always terminated by an implicit deny statement for everything.
Step 4	<p>interface <i>interface-id</i></p> <p>Example:</p> <pre>Switch(config)# interface gigabitethernet 1/0/1</pre>	<p>Specifies the interface to be configured, and enters interface configuration mode.</p> <p>The specified interface must be one of the following:</p> <ul style="list-style-type: none"> • A routed port—A physical port that has been configured as a Layer 3 port by entering the no switchport interface configuration command. You will also need to enable IP PIM sparse-dense-mode on the interface, and join the interface as a statically connected member to an IGMP static group. For a configuration example, see Example: Interface Configuration as a Routed Port • An SVI—A VLAN interface created by using the interface vlan <i>vlan-id</i> global configuration command. You will also need to enable IP PIM sparse-dense-mode on the VLAN, join the VLAN as a statically connected member to an IGMP static group, and then enable IGMP snooping on the VLAN, the IGMP static group, and physical interface. For a configuration example, see Example: Interface Configuration as an SVI <p>These interfaces must have IP addresses assigned to them.</p>
Step 5	<p>ip multicast boundary <i>access-list-number</i></p> <p>Example:</p> <pre>Switch(config-if)# ip multicast boundary 12</pre>	<p>Configures the boundary, specifying the access list you created in Step 2.</p> <p>Note To remove the boundary, use the no ip multicast boundary interface configuration command.</p>
Step 6	<p>end</p> <p>Example:</p> <pre>Switch(config)# end</pre>	Returns to privileged EXEC mode.
Step 7	<p>show running-config</p> <p>Example:</p> <pre>Switch# show running-config</pre>	Verifies your entries.
Step 8	<p>copy running-config startup-config</p> <p>Example:</p> <pre>Switch# copy running-config startup-config</pre>	(Optional) Saves your entries in the configuration file.

Related Topics

[Example: Defining the IP Multicast Boundary to Deny Auto-RP Information](#), on page 96

Configuring Multicast VRFs

For complete syntax and usage information for the commands, see the switch command reference for this release and the *Cisco IOS IP Multicast Command Reference*.

For more information about configuring a multicast within a Multi-VRF CE, see the *IP Routing: Protocol-Independent Configuration Guide, Cisco IOS Release 15S*.

DETAILED STEPS

	Command or Action	Purpose
Step 1	configure terminal Example: Switch# configure terminal	Enters the global configuration mode.
Step 2	ip routing Example: Switch(config)# ip routing	Enables IP routing mode.
Step 3	ip vrf vrf-name Example: Switch(config)# ip vrf vpn1	Names the VRF, and enter VRF configuration mode.
Step 4	rd route-distinguisher Example: Switch(config-vrf)# rd 100:2	Creates a VRF table by specifying a route distinguisher. Enter either an AS number and an arbitrary number (xxx:y) or an IP address and an arbitrary number (A.B.C.D:y)
Step 5	route-target {export import both} <i>route-target-ext-community</i> Example: Switch(config-vrf)# route-target import 100:2	Creates a list of import, export, or import and export route target communities for the specified VRF. Enter either an AS system number and an arbitrary number (xxx:y) or an IP address and an arbitrary number (A.B.C.D:y). The <i>route-target-ext-community</i> should be the same as the <i>route-distinguisher</i> entered in Step 4.
Step 6	import map route-map Example: Switch(config-vrf)# import map importmap1	(Optional) Associates a route map with the VRF.

	Command or Action	Purpose
Step 7	ip multicast-routing vrf <i>vrf-name</i> distributed Example: Switch(config-vrf)# ip multicast-routing vrf vpnl distributed	(Optional) Enables global multicast routing for VRF table.
Step 8	interface <i>interface-id</i> Example: Switch(config-vrf)# interface gigabitethernet 1/0/2	Specifies the Layer 3 interface to be associated with the VRF, and enter interface configuration mode. The interface can be a routed port or an SVI.
Step 9	ip vrf forwarding <i>vrf-name</i> Example: Switch(config-if)# ip vrf forwarding vpnl	Associates the VRF with the Layer 3 interface.
Step 10	ip address <i>ip-address</i> mask Example: Switch(config-if)# ip address 10.1.5.1 255.255.255.0	Configures IP address for the Layer 3 interface.
Step 11	ip pim sparse-dense mode Example: Switch(config-if)# ip pim sparse-dense mode	Enables PIM on the VRF-associated Layer 3 interface.
Step 12	end Example: Switch(config)# end	Returns to privileged EXEC mode.
Step 13	show ip vrf [brief detail interfaces] [<i>vrf-name</i>] Example: Switch# show ip vrf detail vpnl	Verifies the configuration. Displays information about the configured VRFs.
Step 14	copy running-config startup-config Example: Switch# copy running-config startup-config	(Optional) Saves your entries in the configuration file.

Advertising Multicast Multimedia Sessions Using SAP Listener

Enable SAP listener support when you want to use session description and announcement protocols and applications to assist the advertisement of multicast multimedia conferences and other multicast sessions and to communicate the relevant session setup information to prospective participants.

SUMMARY STEPS

1. **enable**
2. **configure terminal**
3. **ip sap cache-timeout** *minutes*
4. **interface** *type number*
5. **ip sap listen**
6. **end**
7. **clear ip sap** [*group-address* | "*session-name*"]
8. **show ip sap** [*group-address* | "*session-name*"] **detail**

DETAILED STEPS

	Command or Action	Purpose
Step 1	enable Example: Router> enable	Enables privileged EXEC mode. <ul style="list-style-type: none"> • Enter your password if prompted.
Step 2	configure terminal Example: Router# configure terminal	Enters global configuration mode.
Step 3	ip sap cache-timeout <i>minutes</i> Example: Router(config)# ip sap cache-timeout 600	(Optional) Limits how long a SAP cache entry stays active in the cache. <ul style="list-style-type: none"> • By default, SAP cache entries are deleted 24 hours after they are received from the network.
Step 4	interface <i>type number</i> Example: Router(config)# interface ethernet 1	Selects an interface that is connected to hosts on which IGMPv3 can be enabled.
Step 5	ip sap listen Example: Router(config-if)# ip sap listen	Enables the software to listen to session directory announcements.

	Command or Action	Purpose
Step 6	end Example: Router(config-if)# end	Ends the session and returns to EXEC mode.
Step 7	clear ip sap [<i>group-address</i> " <i>session-name</i> "] Example: Router# clear ip sap "Sample Session"	Deletes a SAP cache entry or the entire SAP cache.
Step 8	show ip sap [<i>group-address</i> " <i>session-name</i> " detail] Example: Router# show ip sap 224.2.197.250 detail	(Optional) Displays the SAP cache.

Monitoring and Maintaining Basic IP Multicast Routing

Clearing Caches, Tables, and Databases

You can remove all contents of a particular cache, table, or database. Clearing a cache, table, or database might be necessary when the contents of the particular structure are or suspected to be invalid.

You can use any of the privileged EXEC commands in the following table to clear IP multicast caches, tables, and databases.

Table 12: Commands for Clearing Caches, Tables, and Databases

Command	Purpose
clear ip cgmp	Clears all group entries the Catalyst switches have cached.
clear ip igmp group { <i>group</i> [<i>hostname</i> <i>IP address</i>] vrf name group [<i>hostname</i> <i>IP address</i>] }	Deletes entries from the IGMP cache.
clear ip mroute { * [<i>hostname</i> <i>IP address</i>] vrf name group [<i>hostname</i> <i>IP address</i>] }	Deletes entries from the IP multicast routing table.
clear ip pim auto-rprp address	Clears the auto-RP cache.
clear ip sap [<i>group-address</i> " <i>session-name</i> "]	Deletes the Session Directory Protocol Version 2 cache or an sdr cache entry.

Displaying System and Network Statistics

You can display specific statistics, such as the contents of IP routing tables, caches, and databases.



Note

This release does not support per-route statistics.

You can display information to learn resource usage and solve network problems. You can also display information about node reachability and discover the routing path that packets of your device are taking through the network.

You can use any of the privileged EXEC commands in the following table to display various routing statistics.

Table 13: Commands for Displaying System and Network Statistics

Command	Purpose
ping [<i>group-name</i> <i>group-address</i>]	Sends an ICMP Echo Request to a multicast group address.
show ip igmp groups [<i>group-name</i> <i>group-address</i> <i>type-number</i>]	Displays the multicast groups that are directly connected to the switch and that were learned through IGMP.
show ip igmp interface [<i>type number</i>]	Displays multicast-related information about an interface.
show ip mcache [<i>group</i> [<i>source</i>]]	Displays the contents of the IP fast-switching cache.
show ip mpacket [<i>source-address</i> <i>name</i>] [<i>group-address</i> <i>name</i>] [detail]	Displays the contents of the circular cache-header buffer.
show ip mroute [<i>group-name</i> <i>group-address</i>] [<i>source</i>] [count interface proxy pruned summary verbose]	Displays the contents of the IP multicast routing table.
show ip pim interface [<i>type number</i>] [count detail df stats]	Displays information about interfaces configured for PIM. This command is available in all software images.
show ip pim neighbor [<i>type number</i>]	Lists the PIM neighbors discovered by the switch. This command is available in all software images.
show ip pim rp [<i>group-name</i> <i>group-address</i>]	Displays the RP routers associated with a sparse-mode multicast group. This command is available in all software images.

Command	Purpose
show ip rpf { <i>source-address</i> <i>name</i> }	<p>Displays how the switch is doing Reverse-Path Forwarding (that is, from the unicast routing table, DVMRP routing table, or static mroutes).</p> <p>Command parameters include:</p> <ul style="list-style-type: none"> • <i>Host name</i> or <i>IP address</i>—IP name or group address. • Select—Group-based VRF select information. • vrf—Selects VPN Routing/Forwarding instance.
show ip sap [<i>group</i> " <i>session-name</i> " detail]	<p>Displays the Session Announcement Protocol (SAP) Version 2 cache.</p> <p>Command parameters include:</p> <ul style="list-style-type: none"> • <i>A.B.C.D</i>—IP group address. • <i>WORD</i>—Session name (in double quotes). • detail—Session details.

Displaying Multicast Peers, Packet Rates and Loss Information, and Path Tracing

You can use the privileged EXEC commands in the following table to monitor IP multicast routers, packets, and paths.

Table 14: Commands for Displaying Multicast Peers, Packet Rates and Loss Information, and Path Tracing

Command	Purpose
mrinfo [<i>hostname</i> <i>address</i>] [<i>source-address</i> <i>interface</i>]	Queries a multicast router or multilayer switch about which neighboring multicast devices are peering with it.
mstat <i>source</i> [<i>destination</i>] [<i>group</i>]	Displays IP multicast packet rate and information loss.
mtrace <i>source</i> [<i>destination</i>] [<i>group</i>]	Traces the path from a source to a destination branch for a multicast distribution tree for a given group.

Additional References

Related Documents

Related Topic	Document Title
For complete syntax and usage information for the commands used in this chapter.	<i>Command Reference, Cisco Release 15.2(2)E (Industrial Ethernet 3000 Switch)</i>
Cisco IOS commands	Cisco IOS Master Commands List, All Releases
Cisco IOS IP multicast commands	Cisco IOS IP Multicast Command Reference

Error Message Decoder

Description	Link
To help you research and resolve system error messages in this release, use the Error Message Decoder tool.	https://www.cisco.com/cgi-bin/Support/Errordecoder/index.cgi

Standards and RFCs

Standard/RFC	Title
RFC 1112	<i>Host Extensions for IP Multicasting</i>
RFC 2236	<i>Internet Group Management Protocol, Version 2</i>
RFC 4601	<i>Protocol-Independent Multicast-Sparse Mode (PIM-SM): Protocol Specification</i>

MIBs

MIB	MIBs Link
All supported MIBs for this release.	To locate and download MIBs for selected platforms, Cisco IOS releases, and feature sets, use Cisco MIB Locator found at the following URL: http://www.cisco.com/go/mibs

Technical Assistance

Description	Link
<p>The Cisco Support website provides extensive online resources, including documentation and tools for troubleshooting and resolving technical issues with Cisco products and technologies.</p> <p>To receive security and technical information about your products, you can subscribe to various services, such as the Product Alert Tool (accessed from Field Notices), the Cisco Technical Services Newsletter, and Really Simple Syndication (RSS) Feeds.</p> <p>Access to most tools on the Cisco Support website requires a Cisco.com user ID and password.</p>	<p>http://www.cisco.com/support</p>



Configuring SSM

- [Finding Feature Information](#), page 131
- [Prerequisites for Configuring SSM](#), page 131
- [Restrictions for Configuring SSM](#), page 132
- [Information About SSM and SSM Mapping](#), page 133
- [How to Configure SSM and SSM Mapping](#), page 139
- [Monitoring SSM and SSM Mapping](#), page 149
- [Configuration Examples for SSM and SSM Mapping](#), page 150
- [Additional References](#), page 154

Finding Feature Information

Your software release may not support all the features documented in this module. For the latest caveats and feature information, see [Bug Search Tool](#) and the release notes for your platform and software release. To find information about the features documented in this module, and to see a list of the releases in which each feature is supported, see the feature information table at the end of this module.

Use Cisco Feature Navigator to find information about platform support and Cisco software image support. To access Cisco Feature Navigator, go to www.cisco.com/go/cfn. An account on Cisco.com is not required.

Prerequisites for Configuring SSM

The following are the prerequisites for configuring source-specific multicast (SSM) and SSM mapping:

- Before you configure SSM mapping, you must perform the following tasks:
 - Enable IP multicast routing.
 - Enable PIM sparse mode.
 - Configure SSM.

- Before you configure static SSM mapping, you must configure access control lists (ACLs) that define the group ranges to be mapped to source addresses.
- Before you can configure and use SSM mapping with DNS lookups, you need to add records to a running DNS server. If you do not already have a DNS server running, you need to install one.



Note You can use a product such as *Cisco Network Registrar* to add records to a running DNS server.

Restrictions for Configuring SSM

The following are the restrictions for configuring SSM:

- To run SSM with IGMPv3, SSM must be supported in the Cisco IOS router, the host where the application is running, and the application itself.
- Existing applications in a network predating SSM will not work within the SSM range unless they are modified to support (S, G) channel subscriptions. Therefore, enabling SSM in a network may cause problems for existing applications if they use addresses within the designated SSM range.
- IGMP Snooping—IGMPv3 uses new membership report messages that might not be correctly recognized by older IGMP snooping switches.
- Address management is still necessary to some degree when SSM is used with Layer 2 switching mechanisms. Cisco Group Management Protocol (CGMP), IGMP snooping, or Router-Port Group Management Protocol (RGMP) support only group-specific filtering, not (S, G) channel-specific filtering. If different receivers in a switched network request different (S, G) channels sharing the same group, they do not benefit from these existing mechanisms. Instead, both receivers receive all (S, G) channel traffic and filter out the unwanted traffic on input. Because SSM can re-use the group addresses in the SSM range for many independent applications, this situation can lead to decreased traffic filtering in a switched network. For this reason, it is important to use random IP addresses from the SSM range for an application to minimize the chance for re-use of a single address within the SSM range between different applications. For example, an application service providing a set of television channels should, even with SSM, use a different group for each television (S, G) channel. This setup guarantees that multiple receivers to different channels within the same application service never experience traffic aliasing in networks that include Layer 2 devices.
- In PIM-SSM, the last hop router will continue to periodically send (S, G) join messages if appropriate (S, G) subscriptions are on the interfaces. Therefore, as long as receivers send (S, G) subscriptions, the shortest path tree (SPT) state from the receivers to the source will be maintained, even if the source is not sending traffic for longer periods of time (or even never).

The opposite situation occurs with PIM-SM, where (S, G) state is maintained only if the source is sending traffic and receivers are joining the group. If a source stops sending traffic for more than 3 minutes in PIM-SM, the (S, G) state is deleted and only reestablished after packets from the source arrive again through the RPT (rendezvous point tree). Because no mechanism in PIM-SSM notifies a receiver that a source is active, the network must maintain the (S, G) state in PIM-SSM as long as receivers are requesting receipt of that channel.

The following are the restrictions for configuring SSM mapping:

- The SSM Mapping feature does not share the benefit of full SSM. SSM mapping takes a group G join from a host and identifies this group with an application associated with one or more sources, therefore, it can only support one such application per group G. Nevertheless, full SSM applications may still share the same group also used in SSM mapping.
- Enable IGMPv3 with care on the last hop router when you rely solely on SSM mapping as a transition solution for full SSM. When you enable both SSM mapping and IGMPv3 and the hosts already support IGMPv3 (but not SSM), the hosts send IGMPv3 group reports. SSM mapping does not support these IGMPv3 group reports, and the router does not correctly associate sources with these reports.

Information About SSM and SSM Mapping

SSM Components Overview

SSM is a datagram delivery model that best supports one-to-many applications, also known as broadcast applications. It is an extension of IP multicast in which datagram traffic is forwarded to receivers from only those multicast sources that the receivers have explicitly joined. For multicast groups configured for SSM, only SSM distribution trees (no shared trees) are created.

SSM is a core networking technology for Cisco's implementation of IP multicast solutions targeted for audio and video broadcast application environments and is described in RFC 3569. The following components together support the implementation of SSM:

- Protocol Independent Multicast source-specific mode (PIM-SSM)
- Internet Group Management Protocol Version 3 (IGMPv3)

Protocol Independent Multicast (PIM) SSM, or PIM-SSM, is the routing protocol that supports the implementation of SSM and is derived from PIM sparse mode (PIM-SM). IGMP is the Internet Engineering Task Force (IETF) standards track protocol used for hosts to signal multicast group membership to routers. IGMP Version 3 supports source filtering, which is required for SSM. IGMP For SSM to run with IGMPv3, SSM must be supported in the router, the host where the application is running, and the application itself.

Related Topics

[Configuring SSM](#) , on page 139

[SSM with IGMPv3 Example](#), on page 150

How SSM Differs from Internet Standard Multicast

The standard IP multicast infrastructure in the Internet and many enterprise intranets is based on the PIM-SM protocol and Multicast Source Discovery Protocol (MSDP). These protocols have proved to be reliable, extensive, and efficient. However, they are bound to the complexity and functionality limitations of the Internet Standard Multicast (ISM) service model. For example, with ISM, the network must maintain knowledge about which hosts in the network are actively sending multicast traffic. With SSM, this information is provided by receivers through the source addresses relayed to the last-hop devices by IGMPv3. SSM is an incremental response to the issues associated with ISM and is intended to coexist in the network with the protocols developed for ISM. In general, SSM provides IP multicast service for applications that utilize SSM.

ISM service is described in RFC 1112. This service consists of the delivery of IP datagrams from any source to a group of receivers called the multicast host group. The datagram traffic for the multicast host group consists of datagrams with an arbitrary IP unicast source address S and the multicast group address G as the IP destination address. Systems will receive this traffic by becoming members of the host group. Membership in a host group simply requires signaling the host group through IGMP Version 1, 2, or 3.

In SSM, delivery of datagrams is based on (S, G) channels. Traffic for one (S, G) channel consists of datagrams with an IP unicast source address S and the multicast group address G as the IP destination address. Systems will receive this traffic by becoming members of the (S, G) channel. In both SSM and ISM, no signaling is required to become a source. However, in SSM, receivers must subscribe or unsubscribe to (S, G) channels to receive or not receive traffic from specific sources. In other words, receivers can receive traffic only from (S, G) channels to which they are subscribed, whereas in ISM, receivers need not know the IP addresses of sources from which they receive their traffic. The proposed standard approach for channel subscription signaling utilizes IGMP INCLUDE mode membership reports, which are supported only in IGMP Version 3.

SSM can coexist with the ISM service by applying the SSM delivery model to a configured subset of the IP multicast group address range. The Internet Assigned Numbers Authority (IANA) has reserved the address range from 232.0.0.0 through 232.255.255.255 for SSM applications and protocols. The software allows SSM configuration for an arbitrary subset of the IP multicast address range from 224.0.0.0 through 239.255.255.255. When an SSM range is defined, an existing IP multicast receiver application will not receive any traffic when it tries to use addresses in the SSM range unless the application is modified to use explicit (S, G) channel subscription or is SSM-enabled through a URL Rendezvous Directory (URD).

SSM Operations

An established network in which IP multicast service is based on PIM-SM can support SSM services. SSM can also be deployed alone in a network without the full range of protocols that are required for interdomain PIM-SM. That is, SSM does not require an RP, so there is no need for an RP mechanism such as Auto-RP, MSDP, or bootstrap router (BSR).

If SSM is deployed in a network that is already configured for PIM-SM, then only the last-hop routers must be upgraded to a software image that supports SSM. Routers that are not directly connected to receivers do not have to upgrade to a software image that supports SSM. In general, these non-last-hop routers must only run PIM-SM in the SSM range. They may need additional access control configuration to suppress MSDP signaling, registering, or PIM-SM shared-tree operations from occurring within the SSM range.

The SSM mode of operation is enabled by configuring the SSM range using the **ip pim ssm** global configuration command. This configuration has the following effects:

- For groups within the SSM range, (S, G) channel subscriptions are accepted through IGMPv3 INCLUDE mode membership reports.
- PIM operations within the SSM range of addresses change to PIM-SSM, a mode derived from PIM-SM. In this mode, only PIM (S, G) Join and Prune messages are generated by the router. Incoming messages related to rendezvous point tree (RPT) operations are ignored or rejected, and incoming PIM register messages are immediately answered with Register-Stop messages. PIM-SSM is backward-compatible with PIM-SM unless a router is a last-hop router. Therefore, routers that are not last-hop routers can run PIM-SM for SSM groups (for example, if they do not yet support SSM).
- For groups within the SSM range, no MSDP Source-Active (SA) messages within the SSM range will be accepted, generated, or forwarded.

IGMPv3 Host Signaling

IGMPv3 is the third version of the IETF standards track protocol in which hosts signal membership to last-hop routers of multicast groups. IGMPv3 introduces the ability for hosts to signal group membership that allows filtering capabilities with respect to sources. A host can signal either that it wants to receive traffic from all sources sending to a group except for some specific sources (a mode called EXCLUDE) or that it wants to receive traffic only from some specific sources sending to the group (a mode called INCLUDE).

IGMPv3 can operate with both ISM and SSM. In ISM, both EXCLUDE and INCLUDE mode reports are accepted by the last-hop router. In SSM, only INCLUDE mode reports are accepted by the last-hop router.

Benefits of SSM

IP Multicast Address Management Not Required

In the ISM service, applications must acquire a unique IP multicast group address because traffic distribution is based only on the IP multicast group address used. If two applications with different sources and receivers use the same IP multicast group address, then receivers of both applications will receive traffic from the senders of both applications. Even though the receivers, if programmed appropriately, can filter out the unwanted traffic, this situation would cause generally unacceptable levels of unwanted traffic.

Allocating a unique IP multicast group address for an application is still a problem. Most short-lived applications use mechanisms like Session Description Protocol (SDP) and Session Announcement Protocol (SAP) to get a random address, a solution that does not work well with a rising number of applications in the Internet. The best current solution for long-lived applications is described in RFC 2770, but this solution suffers from the restriction that each autonomous system is limited to only 255 usable IP multicast addresses.

In SSM, traffic from each source is forwarded between routers in the network independent of traffic from other sources. Thus different sources can reuse multicast group addresses in the SSM range.

Denial of Service Attacks from Unwanted Sources Inhibited

In SSM, multicast traffic from each individual source will be transported across the network only if it was requested (through IGMPv3, IGMP v3lite, or URD memberships) from a receiver. In contrast, ISM forwards traffic from any active source sending to a multicast group to all receivers requesting that multicast group. In Internet broadcast applications, this ISM behavior is highly undesirable because it allows unwanted sources to easily disturb the actual Internet broadcast source by simply sending traffic to the same multicast group. This situation depletes bandwidth at the receiver side with unwanted traffic and thus disrupts the undisturbed reception of the Internet broadcast. In SSM, this type of denial of service (DoS) attack cannot be made by simply sending traffic to a multicast group.

Easy to Install and Manage

SSM is easy to install and provision in a network because it does not require the network to maintain which active sources are sending to multicast groups. This requirement exists in ISM (with IGMPv1, IGMPv2, or IGMPv3).

The current standard solutions for ISM service are PIM-SM and MSDP. Rendezvous point (RP) management in PIM-SM (including the necessity for Auto-RP or BSR) and MSDP is required only for the network to learn about active sources. This management is not necessary in SSM, which makes SSM easier than ISM to install and manage, and therefore easier than ISM to operationally scale in deployment. Another factor that contributes

to the ease of installation of SSM is the fact that it can leverage preexisting PIM-SM networks and requires only the upgrade of last hop routers to support IGMPv3, IGMP v3lite, or URD.

Ideal for Internet Broadcast Applications

The three benefits previously described make SSM ideal for Internet broadcast-style applications for the following reasons:

- The ability to provide Internet broadcast services through SSM without the need for unique IP multicast addresses allows content providers to easily offer their service (IP multicast address allocation has been a serious problem for content providers in the past).
- The prevention against DoS attacks is an important factor for Internet broadcast services because, with their exposure to a large number of receivers, they are the most common targets for such attacks.
- The ease of installation and operation of SSM makes it ideal for network operators, especially in those cases where content needs to be forwarded between multiple independent PIM domains (because there is no need to manage MSDP for SSM between PIM domains).

SSM Mapping Overview

SSM mapping supports SSM transition when supporting SSM on the end system is impossible or unwanted due to administrative or technical reasons. Using SSM to deliver live streaming video to legacy STBs that do not support IGMPv3 or for applications that do not use the IGMPv3 host stack is a typical application of SSM mapping.

In a typical STB deployment, each TV channel uses one separate IP multicast group and has one active server host sending the TV channel. A single server may of course send multiple TV channels, but each to a different group. In this network environment, if a router receives an IGMPv1 or IGMPv2 membership report for a particular group G, the report implicitly addresses the well-known TV server for the TV channel associated with the multicast group.

SSM mapping introduces a means for the last hop router to discover sources sending to groups. When SSM mapping is configured, if a router receives an IGMPv1 or IGMPv2 membership report for a particular group G, the router translates this report into one or more (S, G) channel memberships for the well-known sources associated with this group.



Note

When the router receives an IGMPv1 or IGMPv2 membership report for group G, the router uses SSM mapping to determine one or more source IP addresses for group G. SSM mapping then translates the membership report as an IGMPv3 report INCLUDE (G, [S1, G], [S2, G]...[Sn, G]) and continues as if it had received an IGMPv3 report. The router then sends out PIM joins toward (S1, G) to (Sn, G) and continues to be joined to these groups as long as it continues to receive the IGMPv1 or IGMPv2 membership reports and as long as it continues to receive the IGMPv1 or IGMPv2 membership reports, and the SSM mapping for the group remains the same. SSM mapping, thus, enables you to leverage SSM for video delivery to legacy STBs that do not support IGMPv3 or for applications that do not take advantage of the IGMPv3 host stack.

SSM mapping enables the last hop router to determine the source addresses either by a statically configured table on the router or by consulting a DNS server. When the statically configured table is changed, or when the DNS mapping changes, the router will leave the current sources associated with the joined groups.

Static SSM Mapping

SSM static mapping enables you to configure the last hop router to use a static map to determine the sources sending to groups. Static SSM mapping requires that you configure access lists (ACLs) to define group ranges. The groups permitted by those ACLs then can be mapped to sources using the `ip igmp static ssm-map` global configuration command.

You can configure static SSM mapping in smaller networks when a DNS is not needed or to locally override DNS mappings that may be temporarily incorrect. When configured, static SSM mappings take precedence over DNS mappings.

Related Topics

[Configuring Static SSM Mapping](#), on page 141

[Verifying SSM Mapping Configuration and Operation](#), on page 147

DNS-Based SSM Mapping

DNS-based SSM mapping enables you to configure the last hop router to perform a reverse DNS lookup to determine sources sending to groups (see the figure below). When DNS-based SSM mapping is configured, the router constructs a domain name that includes the group address G and performs a reverse lookup into the DNS. The router looks up IP address resource records (IP A RRs) to be returned for this constructed domain name and uses the returned IP addresses as the source addresses associated with this group. SSM mapping supports up to 20 sources for each group. The router joins all sources configured for a group.

Figure 7: DNS-Based SSM-Mapping

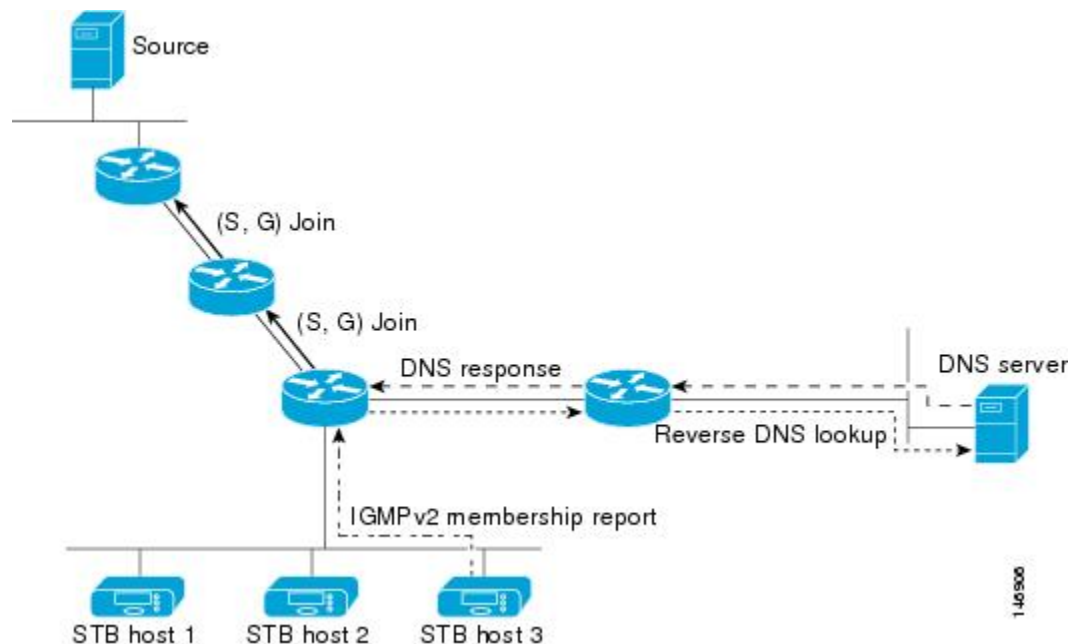

The SSM mapping mechanism that enables the last hop router to join multiple sources for a group can be used to provide source redundancy for a TV broadcast. In this context, the redundancy is provided by the last hop router using SSM mapping to join two video sources simultaneously for the same TV channel. However, to

prevent the last hop router from duplicating the video traffic, it is necessary that the video sources utilize a server-side switchover mechanism where one video source is active while the other backup video source is passive. The passive source waits until an active source failure is detected before sending the video traffic for the TV channel. The server-side switchover mechanism, thus, ensures that only one of the servers is actively sending the video traffic for the TV channel.

To look up one or more source addresses for a group G that includes G1, G2, G3, and G4, the following DNS resource records (RRs) must be configured on the DNS server:

G4.G3.G2.G1 [<i>multicast-domain</i>] [<i>timeout</i>]	IN A <i>source-address-1</i>
	IN A <i>source-address-2</i>
	IN A <i>source-address-n</i>

The *multicast-domain* argument is a configurable DNS prefix. The default DNS prefix is in-addr.arpa. You should only use the default prefix when your installation is either separate from the internet or if the group names that you map are global scope group addresses (RFC 2770 type addresses that you configure for SSM) that you own.

The *timeout* argument configures the length of time for which the router performing SSM mapping will cache the DNS lookup. This argument is optional and defaults to the timeout of the zone in which this entry is configured. The timeout indicates how long the router will keep the current mapping before querying the DNS server for this group. The timeout is derived from the cache time of the DNS RR entry and can be configured for each group/source entry on the DNS server. You can configure this time for larger values if you want to minimize the number of DNS queries generated by the router. Configure this time for a low value if you want to be able to quickly update all routers with new source addresses.

**Note**

Refer to your DNS server documentation for more information about configuring DNS RRs.

To configure DNS-based SSM mapping in the software, you must configure a few global commands but no per-channel specific configuration is needed. There is no change to the configuration for SSM mapping if additional channels are added. When DNS-based SSM mapping is configured, the mappings are handled entirely by one or more DNS servers. All DNS techniques for configuration and redundancy management can be applied to the entries needed for DNS-based SSM mapping.

Related Topics

[Configuring DNS-Based SSM Mapping, on page 143](#)

[Configuring Static Traffic Forwarding with SSM Mapping, on page 145](#)

SSM Mapping Benefits

- The SSM Mapping feature provides almost the same ease of network installation and management as a pure SSM solution based on IGMPv3. Some additional configuration is necessary to enable SSM mapping.
- The SSM benefit of inhibition of DoS attacks applies when SSM mapping is configured. When SSM mapping is configured the only segment of the network that may still be vulnerable to DoS attacks are receivers on the LAN connected to the last hop router. Since those receivers may still be using IGMPv1 and IGMPv2, they are vulnerable to attacks from unwanted sources on the same LAN. SSM mapping,

however, does protect those receivers (and the network path leading towards them) from multicast traffic from unwanted sources anywhere else in the network.

- Address assignment within a network using SSM mapping needs to be coordinated, but it does not need assignment from outside authorities, even if the content from the network is to be transited into other networks.

How to Configure SSM and SSM Mapping

Configuring SSM

Follow these steps to configure SSM:

This procedure is optional.

Before You Begin

If you want to use an access list to define the Source Specific Multicast (SSM) range, configure the access list before you reference the access list in the **ip pim ssm** command.

SUMMARY STEPS

1. **enable**
2. **configure terminal**
3. **ip pim ssm [default | range *access-list*]**
4. **interface *type number***
5. **ip pim {sparse-mode | sparse-dense-mode}**
6. **ip igmp version 3**
7. **end**
8. **show running-config**
9. **copy running-config startup-config**

DETAILED STEPS

	Command or Action	Purpose
Step 1	enable Example: Switch> enable	Enables privileged EXEC mode. Enter your password if prompted.
Step 2	configure terminal Example: Switch# configure terminal	Enters the global configuration mode.

	Command or Action	Purpose
Step 3	<p>ip pim ssm [default range <i>access-list</i>]</p> <p>Example:</p> <pre>Switch(config)# ip pim ssm range 20</pre>	Defines the SSM range of IP multicast addresses.
Step 4	<p>interface <i>type number</i></p> <p>Example:</p> <pre>Switch(config)# interface gigabitethernet 1/0/1</pre>	<p>Selects an interface that is connected to hosts on which IGMPv3 can be enabled, and enters the interface configuration mode.</p> <p>The specified interface must be one of the following:</p> <ul style="list-style-type: none"> • A routed port—A physical port that has been configured as a Layer 3 port by entering the no switchport interface configuration command. You will also need to enable IP PIM sparse-dense-mode on the interface, and join the interface as a statically connected member to an IGMP static group. For a configuration example, see Example: Interface Configuration as a Routed Port • An SVI—A VLAN interface created by using the interface vlan <i>vlan-id</i> global configuration command. You will also need to enable IP PIM sparse-dense-mode on the VLAN, join the VLAN as a statically connected member to an IGMP static group, and then enable IGMP snooping on the VLAN, the IGMP static group, and physical interface. For a configuration example, see Example: Interface Configuration as an SVI <p>These interfaces must have IP addresses assigned to them.</p>
Step 5	<p>ip pim {sparse-mode sparse-dense-mode}</p> <p>Example:</p> <pre>Switch(config-if)# ip pim sparse-dense-mode</pre>	Enables PIM on an interface. You must use either sparse mode or sparse-dense mode.
Step 6	<p>ip igmp version 3</p> <p>Example:</p> <pre>Switch(config-if)# ip igmp version 3</pre>	Enables IGMPv3 on this interface. The default version of IGMP is set to Version 2.
Step 7	<p>end</p> <p>Example:</p> <pre>Switch(config)# end</pre>	Returns to privileged EXEC mode.

	Command or Action	Purpose
Step 8	show running-config Example: Switch# <code>show running-config</code>	Verifies your entries.
Step 9	copy running-config startup-config Example: Switch# <code>copy running-config startup-config</code>	(Optional) Saves your entries in the configuration file.

Related Topics

- [SSM Components Overview, on page 133](#)
- [SSM with IGMPv3 Example, on page 150](#)

Configuring SSM Mapping

Configuring Static SSM Mapping

Follow these steps to configure static SSM Mapping:

SUMMARY STEPS

1. `enable`
2. `configure terminal`
3. `ip igmp ssm-map enable`
4. `no ip igmp ssm-map query dns`
5. `ip igmp ssm-map static access-list source-address`
6. `end`
7. `show running-config`
8. `copy running-config startup-config`

DETAILED STEPS

	Command or Action	Purpose
Step 1	<code>enable</code>	Enables privileged EXEC mode. Enter your password if prompted.

	Command or Action	Purpose
	<p>Example:</p> <pre>Switch> enable</pre>	
Step 2	<p>configure terminal</p> <p>Example:</p> <pre>Switch# configure terminal</pre>	Enters the global configuration mode.
Step 3	<p>ip igmp ssm-map enable</p> <p>Example:</p> <pre>Switch(config)# ip igmp ssm-map enable</pre>	<p>Enables SSM mapping for groups in the configured SSM range.</p> <p>Note By default, this command enables DNS-based SSM mapping.</p>
Step 4	<p>no ip igmp ssm-map query dns</p> <p>Example:</p> <pre>Switch(config)# no ip igmp ssm-map query dns</pre>	<p>(Optional) Disables DNS-based SSM mapping.</p> <p>Note Disable DNS-based SSM mapping if you only want to rely on static SSM mapping. By default, the ip igmp ssm-map command enables DNS-based SSM mapping.</p>
Step 5	<p>ip igmp ssm-map static <i>access-list source-address</i></p> <p>Example:</p> <pre>Switch(config)# ip igmp ssm-map static 11 172.16.8.11</pre>	<p>Configures static SSM mapping.</p> <ul style="list-style-type: none"> The ACL supplied for the <i>access-list</i> argument defines the groups to be mapped to the source IP address entered for the <i>source-address</i> argument. <p>Note You can configure additional static SSM mappings. If additional SSM mappings are configured and the router receives an IGMPv1 or IGMPv2 membership report for a group in the SSM range, the switch determines the source addresses associated with the group by walking each configured ip igmp ssm-map static command. The switch associates up to 20 sources per group.</p> <p>Repeat Step to configure additional static SSM mappings, if required.</p>
Step 6	<p>end</p> <p>Example:</p> <pre>Switch(config)# end</pre>	Returns to privileged EXEC mode.
Step 7	<p>show running-config</p> <p>Example:</p> <pre>Switch# show running-config</pre>	Verifies your entries.

	Command or Action	Purpose
Step 8	copy running-config startup-config Example: Switch# copy running-config startup-config	(Optional) Saves your entries in the configuration file.

Related Topics

[Static SSM Mapping, on page 137](#)

Configuring DNS-Based SSM Mapping

Perform this task to configure the last hop router to perform DNS lookups to learn the IP addresses of sources sending to a group.

Before You Begin

- Enable IP multicast routing, enable PIM sparse mode, and configure SSM before performing this task.
- Before you can configure and use SSM mapping with DNS lookups, you need to be able to add records to a running DNS server. If you do not already have a DNS server running, you need to install one.

SUMMARY STEPS

1. **enable**
2. **configure terminal**
3. **ip igmp ssm-map enable**
4. **ip igmp ssm-map query dns**
5. **ip domain multicast** *domain-prefix*
6. **ip name-server** *server-address1* [*server-address2...server-address6*]
7. Repeat Step [Step 6, on page 144](#) to configure additional DNS servers for redundancy, if required.
8. **end**
9. **show running-config**
10. **copy running-config startup-config**

DETAILED STEPS

	Command or Action	Purpose
Step 1	enable	Enables privileged EXEC mode.

	Command or Action	Purpose
	<p>Example:</p> <pre>Switch> enable</pre>	Enter your password if prompted.
Step 2	<p>configure terminal</p> <p>Example:</p> <pre>Switch# configure terminal</pre>	Enters global configuration mode.
Step 3	<p>ip igmp ssm-map enable</p> <p>Example:</p> <pre>Switch(config)# ip igmp ssm-map enable</pre>	Enables SSM mapping for groups in a configured SSM range.
Step 4	<p>ip igmp ssm-map query dns</p> <p>Example:</p> <pre>Switch(config)# ip igmp ssm-map query dns</pre>	<p>(Optional) Enables DNS-based SSM mapping.</p> <ul style="list-style-type: none"> By default, the ip igmp ssm-map command enables DNS-based SSM mapping. Only the noform of this command is saved to the running configuration. <p>Note Use this command to reenble DNS-based SSM mapping if DNS-based SSM mapping is disabled.</p>
Step 5	<p>ip domain multicast <i>domain-prefix</i></p> <p>Example:</p> <pre>Switch(config)# ip domain multicast ssm-map.cisco.com</pre>	<p>(Optional) Changes the domain prefix used for DNS-based SSM mapping.</p> <ul style="list-style-type: none"> By default, the software uses the ip-addr.arpa domain prefix.
Step 6	<p>ip name-server <i>server-address1</i> [<i>server-address2...server-address6</i>]</p> <p>Example:</p> <pre>Switch(config)# ip name-server 10.48.81.21</pre>	Specifies the address of one or more name servers to use for name and address resolution.
Step 7	Repeat Step Step 6, on page 144 to configure additional DNS servers for redundancy, if required.	--
Step 8	<p>end</p> <p>Example:</p> <pre>Switch(config-if)# end</pre>	Returns to privileged EXEC mode.

	Command or Action	Purpose
Step 9	show running-config Example: Switch# <code>show running-config</code>	Verifies your entries.
Step 10	copy running-config startup-config Example: Switch# <code>copy running-config startup-config</code>	(Optional) Saves your entries in the configuration file.

Related Topics

[DNS-Based SSM Mapping](#), on page 137

Configuring Static Traffic Forwarding with SSM Mapping

Follow these steps to configure static traffic forwarding with SSM mapping on the last hop router:

SUMMARY STEPS

1. `enable`
2. `configure terminal`
3. `interface interface-id`
4. `ip igmp static-group group-address source ssm-map`
5. `end`
6. `show running-config`
7. `copy running-config startup-config`

DETAILED STEPS

	Command or Action	Purpose
Step 1	<code>enable</code> Example: Switch> <code>enable</code>	Enables privileged EXEC mode. Enter your password if prompted.

	Command or Action	Purpose
Step 2	<p>configure terminal</p> <p>Example:</p> <pre>Switch# configure terminal</pre>	Enters the global configuration mode.
Step 3	<p>interface <i>interface-id</i></p> <p>Example:</p> <pre>Switch(config)# interface gigabitethernet 1/0/1</pre>	<p>Selects an interface on which to statically forward traffic for a multicast group using SSM mapping, and enters interface configuration mode.</p> <p>The specified interface must be one of the following:</p> <ul style="list-style-type: none"> • A routed port—A physical port that has been configured as a Layer 3 port by entering the no switchport interface configuration command. You will also need to enable IP PIM sparse-dense-mode on the interface, and join the interface as a statically connected member to an IGMP static group. For a configuration example, see Example: Interface Configuration as a Routed Port • An SVI—A VLAN interface created by using the interface vlan <i>vlan-id</i> global configuration command. You will also need to enable IP PIM sparse-dense-mode on the VLAN, join the VLAN as a statically connected member to an IGMP static group, and then enable IGMP snooping on the VLAN, the IGMP static group, and physical interface. For a configuration example, see Example: Interface Configuration as an SVI <p>These interfaces must have IP addresses assigned to them.</p> <p>Note Static forwarding of traffic with SSM mapping works with either DNS-based SSM mapping or statically configured SSM mapping.</p>
Step 4	<p>ip igmp static-group <i>group-address</i> source ssm-map</p> <p>Example:</p> <pre>Switch(config-if)# ip igmp static-group 239.1.2.1 source ssm-map</pre>	<p>Configures SSM mapping to statically forward a (S, G) channel from the interface.</p> <p>Use this command if you want to statically forward SSM traffic for certain groups. Use DNS-based SSM mapping to determine the source addresses of the channels.</p>
Step 5	<p>end</p> <p>Example:</p> <pre>Switch(config)# end</pre>	Returns to privileged EXEC mode.
Step 6	<p>show running-config</p> <p>Example:</p> <pre>Switch# show running-config</pre>	Verifies your entries.

	Command or Action	Purpose
Step 7	copy running-config startup-config Example: Switch# copy running-config startup-config	(Optional) Saves your entries in the configuration file.

Related Topics

[DNS-Based SSM Mapping, on page 137](#)

Verifying SSM Mapping Configuration and Operation

Follow these steps to verify SSM mapping configuration and operation:

SUMMARY STEPS

1. **enable**
2. **show ip igmp ssm-mapping**
3. **show ip igmp ssm-mapping** *group-address*
4. **show ip igmp groups** [*group-name* | *group-address* | *interface-type interface-number*] [**detail**]
5. **show host**
6. **debug ip igmp** *group-address*

DETAILED STEPS

	Command or Action	Purpose
Step 1	enable Example: Switch> enable	Enables privileged EXEC mode. Enter your password if prompted.
Step 2	show ip igmp ssm-mapping Example: Switch# show ip igmp ssm-mapping SSM Mapping : Enabled DNS Lookup : Enabled Mcast domain : ssm-map.cisco.com Name servers : 10.0.0.3 10.0.0.4	(Optional) Displays information about SSM mapping configuration.

	Command or Action	Purpose
Step 3	<p>show ip igmp ssm-mapping group-address</p> <p>Example:</p> <pre>Switch# show ip igmp ssm-mapping 232.1.1.4 Group address: 232.1.1.4 Database : DNS DNS name : 4.1.1.232.ssm-map.cisco.com Expire time : 860000 Source list : 172.16.8.5 : 172.16.8.6</pre>	<p>(Optional) Displays the sources that SSM mapping uses for a particular group.</p> <p>The example here shows information about the configured DNS-based SSM mapping. Here the router has used DNS-based mapping to map group 232.1.1.4 to sources 172.16.8.5 and 172.16.8.6. The timeout for this entry is 860000 milliseconds (860 seconds).</p>
Step 4	<p>show ip igmp groups [group-name group-address interface-type interface-number] [detail]</p> <p>Example:</p> <pre>Switch# show ip igmp group 232.1.1.4 detail Interface: GigabitEthernet2/0/0 Group: 232.1.1.4 SSM Uptime: 00:03:20 Group mode: INCLUDE Last reporter: 0.0.0.0 CSR Grp Exp: 00:02:59 Group source list: (C - Cisco Src Report, U - URD, R - Remote, S - Static, M - SSM Mapping) Source Address Uptime v3 Exp CSR Exp Fwd Flags 00:02:59 Yes CM 172.16.8.3 00:03:20 stopped 172.16.8.4 00:03:20 stopped 00:02:59 Yes CM 172.16.8.5 00:03:20 stopped 00:02:59 Yes CM 172.16.8.6 00:03:20 stopped 00:02:59 Yes CM</pre>	<p>(Optional) Displays the multicast groups with receivers that are directly connected to the router and that were learned through IGMP.</p> <p>In the example the “M” flag indicates that SSM mapping is configured.</p>
Step 5	<p>show host</p> <p>Example:</p> <pre>Switch# show host Default domain is cisco.com Name/address lookup uses domain service Name servers are 10.48.81.21 Codes: UN - unknown, EX - expired, OK - OK, ?? - revalidate temp - temporary, perm - permanent NA - Not Applicable None - Not defined Host Port Flags Age Type Address(es) 10.0.0.0.ssm-map.cisco.c None (temp, OK) 0 IP 172.16.8.5 172.16.8.6 172.16.8.3</pre>	<p>(Optional) Displays the default domain name, the style of name lookup service, a list of name server hosts, and the cached list of hostnames and addresses.</p>

	Command or Action	Purpose
Step 6	debug ip igmp <i>group-address</i> Example: Switch# debug ip igmp IGMP(0): Convert IGMPv2 report (*,232.1.2.3) to IGMPv3 with 2 source(s) using STATIC. Switch# debug ip igmp IGMP(0): Convert IGMPv2 report (*,232.1.2.3) to IGMPv3 with 2 source(s) using DNS. Switch# debug ip igmp IGMP(0): DNS source lookup failed for (*, 232.1.2.3), IGMPv2 report failed	(Optional) Displays the IGMP packets received and sent and IGMP host-related events. In the first example, the output indicates that the router is converting an IGMPv2 join for group G into an IGMPv3 join. In the second example, the output indicates that a DNS lookup has succeeded. In the third example, the output indicates that DNS-based SSM mapping is enabled and a DNS lookup has failed:

Related Topics

[Static SSM Mapping](#), on page 137

Monitoring SSM and SSM Mapping

Monitoring SSM

To monitor SSM, use the following commands in privileged EXEC mode, as needed:

Command	Purpose
Switch# show ip igmp groups detail	Displays the (S, G) channel subscription through IGMPv3.
Switch# show ip mroute	Displays whether a multicast group supports SSM service or whether a source-specific host report was received.

Monitoring SSM Mapping

Use the privileged EXEC commands in the following table to monitor SSM mapping.

Table 15: SSM Mapping Monitoring Commands

Command	Purpose
Switch# show ip igmp ssm-mapping	Displays information about SSM mapping.

Command	Purpose
Switch# show ip igmp ssm-mapping <i>group-address</i>	Displays the sources that SSM mapping uses for a particular group.
Switch# show ip igmp groups [<i>group-name</i> <i>group-address</i> <i>interface-type interface-number</i>] [detail]	Displays the multicast groups with receivers that are directly connected to the router and that were learned through IGMP.
Switch# show host	Displays the default domain name, the style of name lookup service, a list of name server hosts, and the cached list of hostnames and addresses.
Switch# debug ip igmp <i>group-address</i>	Displays the IGMP packets received and sent and IGMP host-related events.

Configuration Examples for SSM and SSM Mapping

SSM with IGMPv3 Example

The following example shows how to configure a device (running IGMPv3) for SSM:

```
ip multicast-routing
!
interface GigabitEthernet3/1/0
 ip address 172.21.200.203 255.255.255.0
 description backbone interface
 ip pim sparse-mode
!
interface GigabitEthernet3/2/0
 ip address 131.108.1.2 255.255.255.0
 ip pim sparse-mode
 description ethernet connected to hosts
 ip igmp version 3
!
ip pim ssm default
```

Related Topics

[Configuring SSM](#) , on page 139

[SSM Components Overview](#) , on page 133

SSM Filtering Example

The following example shows how to configure filtering on legacy RP routers running software releases that do not support SSM routing. This filtering will suppress all unwanted PIM-SM and MSDP traffic in the SSM range. Without this filtering, SSM will still operate, but there may be additional RPT traffic if legacy first hop and last hop routers exist in the network.

```
ip access-list extended no-ssm-range
 deny ip any 232.0.0.0 0.255.255.255 ! SSM range
```

```

    permit ip any any
    ! Deny registering in SSM range
ip pim accept-register list no-ssm-range
ip access-list extended msdp-nono-list
    deny ip any 232.0.0.0 0.255.255.255 ! SSM Range
    ! .
    ! .
    ! .
    ! See ftp://ftpeng.cisco.com/ipmulticast/config-notes/msdp-sa-filter.txt for other SA
    ! messages that typically need to be filtered.
    permit ip any any
    ! Filter generated SA messages in SSM range. This configuration is only needed if there
    ! are directly connected sources to this router. The "ip pim accept-register" command
    ! filters remote sources.
ip msdp redistribute list msdp-nono-list
    ! Filter received SA messages in SSM range. "Filtered on receipt" means messages are
    ! neither processed or forwarded. Needs to be configured for each MSDP peer.
ip msdp sa-filter in msdp-peer1 list msdp-nono-list
    ! .
    ! .
    ! .
ip msdp sa-filter in msdp-peerN list msdp-nono-list

```

SSM Mapping Example

The following configuration example shows a router configuration for SSM mapping. This example also displays a range of other IGMP and SSM configuration options to show compatibility between features. Do not use this configuration example as a model unless you understand all of the features used in the example.



Note

Address assignment in the global SSM range 232.0.0.0/8 should be random. If you copy parts or all of this sample configuration, make sure to select a random address range but not 232.1.1.x as shown in this example. Using a random address range minimizes the possibility of address collision and may prevent conflicts when other SSM content is imported while SSM mapping is used.

```

!
no ip domain lookup
ip domain multicast ssm.map.cisco.com
ip name-server 10.48.81.21
!
!
ip multicast-routing distributed
ip igmp ssm-map enable
ip igmp ssm-map static 10 172.16.8.10
ip igmp ssm-map static 11 172.16.8.11
!
!
!
!
interface GigabitEthernet0/0/0
description Sample IGMP Interface Configuration for SSM-Mapping Example
ip address 10.20.1.2 255.0.0.0
ip pim sparse-mode
ip igmp last-member-query-interval 100
ip igmp static-group 232.1.2.1 source ssm-map
ip igmp version 3
ip igmp explicit-tracking
ip igmp limit 2
ip igmp v3lite
ip urd
!
.

```

```

.
.
!
ip pim ssm default
!
access-list 10 permit 232.1.2.10
access-list 11 permit 232.1.2.0 0.0.0.255
!

```

This table describes the significant commands shown in the SSM mapping configuration example.

Table 16: SSM Mapping Configuration Example Command Descriptions

Command	Description
no ip domain lookup	Disables IP DNS-based hostname-to-address translation. Note The no ip domain-list command is shown in the configuration only to demonstrate that disabling IP DNS-based hostname-to-address translation does not conflict with configuring SSM mapping. If this command is enabled, the Cisco IOS XE software will try to resolve unknown strings as hostnames.
ip domain multicast ssm-map.cisco.com	Specifies ssm-map.cisco.com as the domain prefix for SSM mapping.
ip name-server 10.48.81.21	Specifies 10.48.81.21 as the IP address of the DNS server to be used by SSM mapping and any other service in the software that utilizes DNS.
ip multicast-routing	Enables IP multicast routing.
ip igmp ssm-map enable	Enables SSM mapping.
ip igmp ssm-map static 10 172.16.8.10	Configures the groups permitted by ACL 10 to use source address 172.16.8.10. • In this example, ACL 10 permits all groups in the 232.1.2.0/25 range except 232.1.2.10.
ip igmp ssm-map static 11 172.16.8.11	Configures the groups permitted by ACL 11 to use source address 172.16.8.11. • In this example, ACL 11 permits group 232.1.2.10.
ip pim sparse-mode	Enables PIM sparse mode.

Command	Description
ip igmp last-member-query-interval 100	Reduces the leave latency for IGMPv2 hosts. Note This command is not required for configuring SSM mapping; however, configuring this command can be beneficial for IGMPv2 hosts relying on SSM mapping.
ip igmp static-group 232.1.2.1 source ssm-map	Configures SSM mapping to be used to determine the sources associated with group 232.1.2.1. The resulting (S, G) channels are statically forwarded.
ip igmp version 3	Enables IGMPv3 on this interface. Note This command is shown in the configuration only to demonstrate that IGMPv3 can be configured simultaneously with SSM mapping; however, it is not required.
ip igmp explicit-tracking	Minimizes the leave latency for IGMPv3 host leaving a multicast channel. Note This command is not required for configuring SSM mapping.
ip igmp limit 2	Limits the number of IGMP states resulting from IGMP membership states on a per-interface basis. Note This command is not required for configuring SSM mapping.
ip igmp v3lite	Enables the acceptance and processing of IGMP v3lite membership reports on this interface. Note This command is shown in the configuration only to demonstrate that IGMP v3lite can be configured simultaneously with SSM mapping; however, it is not required.
ip urd	Enables interception of TCP packets sent to the reserved URD port 465 on an interface and processing of URD channel subscription reports. Note This command is shown in the configuration only to demonstrate that URD can be configured simultaneously with SSM mapping; however, it is not required.
ip pim ssm default	Configures SSM service. <ul style="list-style-type: none"> • The default keyword defines the SSM range access list as 232/8.

Command	Description
access-list 10 permit 232.1.2.10 access-list 11 permit 232.1.2.0 0.0.0.255	Configures the ACLs to be used for static SSM mapping. Note These are the ACLs that are referenced by the ip igmp ssm-map static commands in this configuration example.

DNS Server Configuration Example

To configure DNS-based SSM mapping, you need to create a DNS server zone or add records to an existing zone. If the routers that are using DNS-based SSM mapping are also using DNS for other purposes besides SSM mapping, you should use a normally-configured DNS server. If DNS-based SSM mapping is the only DNS implementation being used on the router, you can configure a fake DNS setup with an empty root zone, or a root zone that points back to itself.

The following example shows how to create a zone and import the zone data using Network Registrar:

```
Router> zone 1.1.232.ssm-map.cisco.com. create primary file=named.ssm-map
100 Ok
Router> dns reload
100 Ok
```

The following example shows how to import the zone files from a named.conf file for BIND 8:

```
Router> ::import named.conf /etc/named.conf
Router> dns reload
100 ok:
```



Note

Network Registrar version 8.0 and later support import BIND 8 format definitions.

Additional References

Related Documents

Related Topic	Document Title
For complete syntax and usage information for the commands used in this chapter.	<i>Command Reference, Cisco Release 15.2(2)E (Industrial Ethernet 3000 Switch)</i>
Cisco IOS commands	Cisco IOS Master Commands List, All Releases

Error Message Decoder

Description	Link
To help you research and resolve system error messages in this release, use the Error Message Decoder tool.	https://www.cisco.com/cgi-bin/Support/Errordecoder/index.cgi

Standards and RFCs

Standard/RFC	Title
RFC 4601	<i>Protocol-Independent Multicast-Sparse Mode (PIM-SM): Protocol Specification</i>

MIBs

MIB	MIBs Link
All supported MIBs for this release.	To locate and download MIBs for selected platforms, Cisco IOS releases, and feature sets, use Cisco MIB Locator found at the following URL: http://www.cisco.com/go/mibs

Technical Assistance

Description	Link
<p>The Cisco Support website provides extensive online resources, including documentation and tools for troubleshooting and resolving technical issues with Cisco products and technologies.</p> <p>To receive security and technical information about your products, you can subscribe to various services, such as the Product Alert Tool (accessed from Field Notices), the Cisco Technical Services Newsletter, and Really Simple Syndication (RSS) Feeds.</p> <p>Access to most tools on the Cisco Support website requires a Cisco.com user ID and password.</p>	http://www.cisco.com/support



Configuring IGMP Snooping and Multicast VLAN Registration

- [Finding Feature Information](#), page 157
- [Prerequisites for Configuring IGMP Snooping and MVR](#), page 157
- [Restrictions for Configuring IGMP Snooping and MVR](#), page 158
- [Information About IGMP Snooping and MVR](#), page 160
- [How to Configure IGMP Snooping and MVR](#), page 169
- [Monitoring IGMP Snooping and MVR](#), page 200
- [Configuration Examples for IGMP Snooping and MVR](#), page 203
- [Additional References](#), page 206

Finding Feature Information

Your software release may not support all the features documented in this module. For the latest caveats and feature information, see [Bug Search Tool](#) and the release notes for your platform and software release. To find information about the features documented in this module, and to see a list of the releases in which each feature is supported, see the feature information table at the end of this module.

Use Cisco Feature Navigator to find information about platform support and Cisco software image support. To access Cisco Feature Navigator, go to www.cisco.com/go/cfn. An account on Cisco.com is not required.

Prerequisites for Configuring IGMP Snooping and MVR

Prerequisites for IGMP Snooping

Observe these guidelines when configuring the IGMP snooping querier:

- Configure the VLAN in global configuration mode.

- Configure an IP address on the VLAN interface. When enabled, the IGMP snooping querier uses the IP address as the query source address.
- If there is no IP address configured on the VLAN interface, the IGMP snooping querier tries to use the configured global IP address for the IGMP querier. If there is no global IP address specified, the IGMP querier tries to use the VLAN switch virtual interface (SVI) IP address (if one exists). If there is no SVI IP address, the switch uses the first available IP address configured on the switch. The first IP address available appears in the output of the **show ip interface** privileged EXEC command. The IGMP snooping querier does not generate an IGMP general query if it cannot find an available IP address on the switch.
- The IGMP snooping querier supports IGMP Versions 1 and 2.
- When administratively enabled, the IGMP snooping querier moves to the nonquerier state if it detects the presence of a multicast router in the network.
- When it is administratively enabled, the IGMP snooping querier moves to the operationally disabled state under these conditions:
 - IGMP snooping is disabled in the VLAN.
 - PIM is enabled on the SVI of the corresponding VLAN.

Related Topics

[Configuring the IGMP Snooping Querier](#) , on page 184

[IGMP Snooping](#), on page 160

Restrictions for Configuring IGMP Snooping and MVR

Restrictions for IGMP Snooping

The following are the restrictions for IGMP snooping:

- The switch supports IGMPv3 snooping based only on the destination multicast MAC address. It does not support snooping based on the source MAC address or on proxy reports.
- IGMPv3 join and leave messages are not supported on switches running IGMP filtering or Multicast VLAN registration (MVR).
- IGMP report suppression is supported only when the multicast query has IGMPv1 and IGMPv2 reports. This feature is not supported when the query includes IGMPv3 reports.
- The IGMP configurable leave time is only supported on hosts running IGMP Version 2. IGMP version 2 is the default version for the switch.

The actual leave latency in the network is usually the configured leave time. However, the leave time might vary around the configured time, depending on real-time CPU load conditions, network delays and the amount of traffic sent through the interface.

- The IGMP throttling action restriction can be applied only to Layer 2 ports. You can use **ip igmp max-groups action replace** interface configuration command on a logical EtherChannel interface but cannot use it on ports that belong to an EtherChannel port group.

When the maximum group limitation is set to the default (no maximum), entering the **ip igmp max-groups action {deny | replace}** command has no effect.

If you configure the throttling action and set the maximum group limitation after an interface has added multicast entries to the forwarding table, the forwarding-table entries are either aged out or removed, depending on the throttling action.

Related Topics

[IGMP Versions, on page 13](#)

[Configuring IGMP Profiles , on page 192](#)

[Applying IGMP Profiles , on page 195](#)

[Setting the Maximum Number of IGMP Groups , on page 196](#)

[Configuring the IGMP Throttling Action , on page 198](#)

[IGMP Filtering and Throttling, on page 167](#)

Restrictions for MVR

The following are restrictions for MVR:

- Only Layer 2 ports participate in MVR. You must configure ports as MVR receiver ports.
- Only one MVR multicast VLAN per switch or switch stack is supported.
- Receiver ports can only be access ports; they cannot be trunk ports. Receiver ports on a switch can be in different VLANs, but should not belong to the multicast VLAN.
- The maximum number of multicast entries (MVR group addresses) that can be configured on a switch (that is, the maximum number of television channels that can be received) is 256.
- MVR multicast data received in the source VLAN and leaving from receiver ports has its time-to-live (TTL) decremented by 1 in the switch.
- Because MVR on the switch uses IP multicast addresses instead of MAC multicast addresses, alias IP multicast addresses are allowed on the switch. However, if the switch is interoperating with Catalyst 3550 or Catalyst 3500 XL switches, you should not configure IP addresses that alias between themselves or with the reserved IP multicast addresses (in the range 224.0.0.xxx).
- Do not configure MVR on private VLAN ports.
- MVR is not supported when multicast routing is enabled on a switch. If you enable multicast routing and a multicast routing protocol while MVR is enabled, MVR is disabled, and you receive a warning message. If you try to enable MVR while multicast routing and a multicast routing protocol are enabled, the operation to enable MVR is cancelled, and you receive an error message.
- MVR data received on an MVR receiver port is not forwarded to MVR source ports.
- MVR does not support IGMPv3 messages.

Information About IGMP Snooping and MVR

IGMP Snooping

Layer 2 switches can use IGMP snooping to constrain the flooding of multicast traffic by dynamically configuring Layer 2 interfaces so that multicast traffic is forwarded to only those interfaces associated with IP multicast devices. As the name implies, IGMP snooping requires the LAN switch to snoop on the IGMP transmissions between the host and the router and to keep track of multicast groups and member ports. When the switch receives an IGMP report from a host for a particular multicast group, the switch adds the host port number to the forwarding table entry; when it receives an IGMP Leave Group message from a host, it removes the host port from the table entry. It also periodically deletes entries if it does not receive IGMP membership reports from the multicast clients.

**Note**

For more information on IP multicast and IGMP, see RFC 1112 and RFC 2236.

The multicast router sends out periodic general queries to all VLANs. All hosts interested in this multicast traffic send join requests and are added to the forwarding table entry. The switch creates one entry per VLAN in the IGMP snooping IP multicast forwarding table for each group from which it receives an IGMP join request.

The switch supports IP multicast group-based bridging, instead of MAC-addressed based groups. With multicast MAC address-based groups, if an IP address being configured translates (aliases) to a previously configured MAC address or to any reserved multicast MAC addresses (in the range 224.0.0.xxx), the command fails. Because the switch uses IP multicast groups, there are no address aliasing issues.

The IP multicast groups learned through IGMP snooping are dynamic. However, you can statically configure multicast groups by using the **ip igmp snooping vlan *vlan-id* static *ip_address* interface *interface-id*** global configuration command. If you specify group membership for a multicast group address statically, your setting supersedes any automatic manipulation by IGMP snooping. Multicast group membership lists can consist of both user-defined and IGMP snooping-learned settings.

You can configure an IGMP snooping querier to support IGMP snooping in subnets without multicast interfaces because the multicast traffic does not need to be routed.

If a port spanning-tree, a port group, or a VLAN ID change occurs, the IGMP snooping-learned multicast groups from this port on the VLAN are deleted.

These sections describe IGMP snooping characteristics:

Related Topics

[Configuring the IGMP Snooping Querier](#), on page 184

[Prerequisites for IGMP Snooping](#), on page 157

[Example: Setting the IGMP Snooping Querier Source Address](#), on page 204

[Example: Setting the IGMP Snooping Querier Maximum Response Time](#), on page 204

[Example: Setting the IGMP Snooping Querier Timeout](#), on page 204

[Example: Setting the IGMP Snooping Querier Feature](#), on page 204

IGMP Versions

The switch supports IGMP version 1, IGMP version 2, and IGMP version 3. These versions are interoperable on the switch. For example, if IGMP snooping is enabled and the querier's version is IGMPv2, and the switch receives an IGMPv3 report from a host, then the switch can forward the IGMPv3 report to the multicast router.

An IGMPv3 switch can receive messages from and forward messages to a device running the Source Specific Multicast (SSM) feature.

Related Topics

[Changing the IGMP Version, on page 22](#)

[Restrictions for IGMP Snooping, on page 158](#)

Joining a Multicast Group

When a host connected to the switch wants to join an IP multicast group and it is an IGMP version 2 client, it sends an unsolicited IGMP join message, specifying the IP multicast group to join. Alternatively, when the switch receives a general query from the router, it forwards the query to all ports in the VLAN. IGMP version 1 or version 2 hosts wanting to join the multicast group respond by sending a join message to the switch. The switch CPU creates a multicast forwarding-table entry for the group if it is not already present. The CPU also adds the interface where the join message was received to the forwarding-table entry. The host associated with that interface receives multicast traffic for that multicast group.

Figure 8: Initial IGMP Join Message

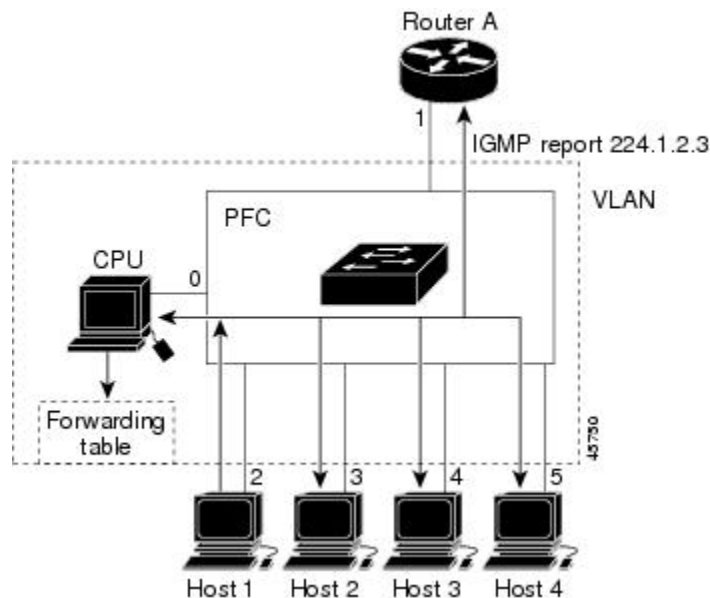

Router A sends a general query to the switch, which forwards the query to ports 2 through 5, all of which are members of the same VLAN. Host 1 wants to join multicast group 224.1.2.3 and multicasts an IGMP membership report (IGMP join message) to the group. The switch CPU uses the information in the IGMP report to set up a forwarding-table entry that includes the port numbers connected to Host 1 and to the router.

Table 17: IGMP Snooping Forwarding Table

Destination Address	Type of Packet	Ports
224.1.2.3	IGMP	1, 2

The switch hardware can distinguish IGMP information packets from other packets for the multicast group. The information in the table tells the switching engine to send frames addressed to the 224.1.2.3 multicast IP address that are not IGMP packets to the router and to the host that has joined the group.

If another host (for example, Host 4) sends an unsolicited IGMP join message for the same group, the CPU receives that message and adds the port number of Host 4 to the forwarding table. Because the forwarding table directs IGMP messages only to the CPU, the message is not flooded to other ports on the switch. Any known multicast traffic is forwarded to the group and not to the CPU.

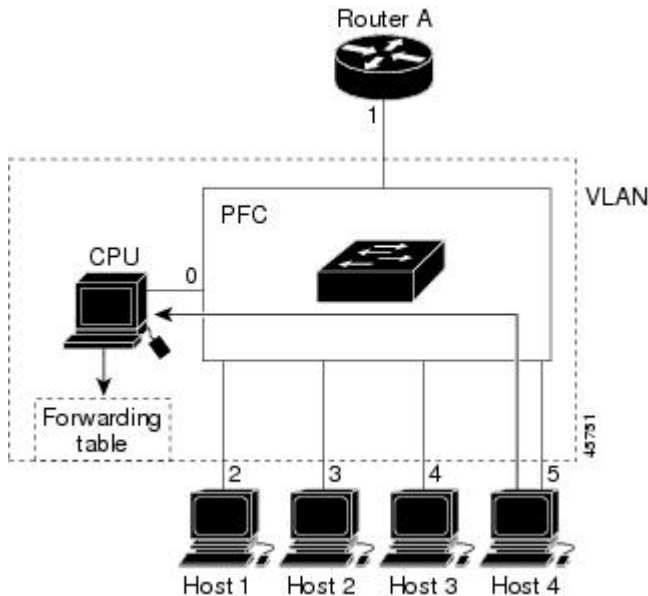
Figure 9: Second Host Joining a Multicast Group**Table 18: Updated IGMP Snooping Forwarding Table**

Destination Address	Type of Packet	Ports
224.1.2.3	IGMP	1, 2, 5

Related Topics

[Configuring a Host Statically to Join a Group](#), on page 174

[Example: Configuring a Host Statically to Join a Group](#), on page 203

Leaving a Multicast Group

The router sends periodic multicast general queries, and the switch forwards these queries through all ports in the VLAN. Interested hosts respond to the queries. If at least one host in the VLAN wants to receive multicast traffic, the router continues forwarding the multicast traffic to the VLAN. The switch forwards multicast group traffic only to those hosts listed in the forwarding table for that IP multicast group maintained by IGMP snooping.

When hosts want to leave a multicast group, they can silently leave, or they can send a leave message. When the switch receives a leave message from a host, it sends a group-specific query to learn if any other devices connected to that interface are interested in traffic for the specific multicast group. The switch then updates the forwarding table for that MAC group so that only those hosts interested in receiving multicast traffic for the group are listed in the forwarding table. If the router receives no reports from a VLAN, it removes the group for the VLAN from its IGMP cache.

Immediate Leave

The switch uses IGMP snooping Immediate Leave to remove from the forwarding table an interface that sends a leave message without the switch sending group-specific queries to the interface. The VLAN interface is pruned from the multicast tree for the multicast group specified in the original leave message. Immediate Leave ensures optimal bandwidth management for all hosts on a switched network, even when multiple multicast groups are simultaneously in use.

Immediate Leave is only supported on IGMP version 2 hosts. IGMP version 2 is the default version for the switch.

**Note**

You should use the Immediate Leave feature only on VLANs where a single host is connected to each port. If Immediate Leave is enabled on VLANs where more than one host is connected to a port, some hosts may be dropped inadvertently.

Related Topics

[Enabling IGMP Immediate Leave](#) , on page 176

[Example: Enabling IGMP Immediate Leave](#), on page 203

IGMP Configurable-Leave Timer

You can configure the time that the switch waits after sending a group-specific query to determine if hosts are still interested in a specific multicast group. The IGMP leave response time can be configured from 100 to 32767 milliseconds.

Related Topics

[Configuring the IGMP Leave Timer](#) , on page 178

IGMP Report Suppression

Note

IGMP report suppression is supported only when the multicast query has IGMPv1 and IGMPv2 reports. This feature is not supported when the query includes IGMPv3 reports.

The switch uses IGMP report suppression to forward only one IGMP report per multicast router query to multicast devices. When IGMP report suppression is enabled (the default), the switch sends the first IGMP report from all hosts for a group to all the multicast routers. The switch does not send the remaining IGMP reports for the group to the multicast routers. This feature prevents duplicate reports from being sent to the multicast devices.

If the multicast router query includes requests only for IGMPv1 and IGMPv2 reports, the switch forwards only the first IGMPv1 or IGMPv2 report from all hosts for a group to all the multicast routers.

If the multicast router query also includes requests for IGMPv3 reports, the switch forwards all IGMPv1, IGMPv2, and IGMPv3 reports for a group to the multicast devices.

If you disable IGMP report suppression, all IGMP reports are forwarded to the multicast routers.

Related Topics

[Disabling IGMP Report Suppression](#) , on page 186

Default IGMP Snooping Configuration

This table displays the default IGMP snooping configuration for the switch.

Table 19: Default IGMP Snooping Configuration

Feature	Default Setting
IGMP snooping	Enabled globally and per VLAN
Multicast routers	None configured
IGMP snooping Immediate Leave	Disabled
Static groups	None configured
TCN ¹ flood query count	2
TCN query solicitation	Disabled
IGMP snooping querier	Disabled
IGMP report suppression	Enabled

¹ (1) TCN = Topology Change Notification

Related Topics

[Enabling or Disabling IGMP Snooping on a Switch](#) , on page 169

[Enabling or Disabling IGMP Snooping on a VLAN Interface](#), on page 170

Multicast VLAN Registration

Multicast VLAN Registration (MVR) is designed for applications using wide-scale deployment of multicast traffic across an Ethernet ring-based service-provider network (for example, the broadcast of multiple television channels over a service-provider network). MVR allows a subscriber on a port to subscribe and unsubscribe to a multicast stream on the network-wide multicast VLAN. It allows the single multicast VLAN to be shared in the network while subscribers remain in separate VLANs. MVR provides the ability to continuously send multicast streams in the multicast VLAN, but to isolate the streams from the subscriber VLANs for bandwidth and security reasons.

These sections describe MVR:

MVR and IGMP



Note MVR can coexist with IGMP snooping on a switch.

MVR assumes that subscriber ports subscribe and unsubscribe (join and leave) these multicast streams by sending out IGMP join and leave messages. These messages can originate from an IGMP version-2-compatible host with an Ethernet connection. Although MVR operates on the underlying method of IGMP snooping, the two features operate independently of each other. One can be enabled or disabled without affecting the behavior of the other feature. However, if IGMP snooping and MVR are both enabled, MVR reacts only to join and leave messages from multicast groups configured under MVR. Join and leave messages from all other multicast groups are managed by IGMP snooping.

The switch CPU identifies the MVR IP multicast streams and their associated IP multicast group in the switch forwarding table, intercepts the IGMP messages, and modifies the forwarding table to include or remove the subscriber as a receiver of the multicast stream, even though the receivers might be in a different VLAN from the source. This forwarding behavior selectively allows traffic to cross between different VLANs.

Modes of Operation

You can set the switch for compatible or dynamic mode of MVR operation:

- In compatible mode, multicast data received by MVR hosts is forwarded to all MVR data ports, regardless of MVR host membership on those ports. The multicast data is forwarded only to those receiver ports that MVR hosts have joined, either by IGMP reports or by MVR static configuration. IGMP reports received from MVR hosts are never forwarded from MVR data ports that were configured in the switch.
- In dynamic mode, multicast data received by MVR hosts on the switch is forwarded from only those MVR data and client ports that the MVR hosts have joined, either by IGMP reports or by MVR static configuration. Any IGMP reports received from MVR hosts are also forwarded from all the MVR data ports in the host. This eliminates using unnecessary bandwidth on MVR data port links, which occurs when the switch runs in compatible mode.

MVR in a Multicast Television Application

In a multicast television application, a PC or a television with a set-top box can receive the multicast stream. Multiple set-top boxes or PCs can be connected to one subscriber port, which is a switch port configured as an MVR receiver port.

The following is an example configuration.

Figure 10: Multicast VLAN Registration Example

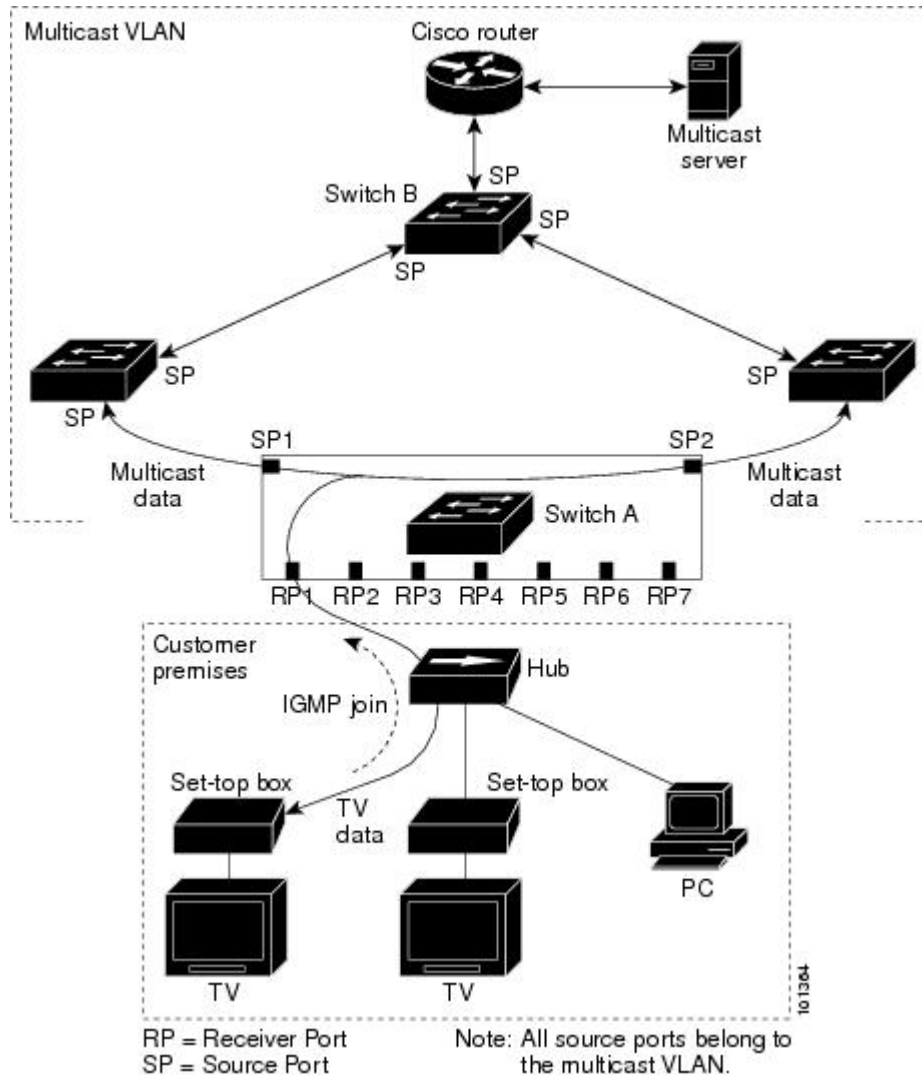

In this example configuration, DHCP assigns an IP address to the set-top box or the PC. When a subscriber selects a channel, the set-top box or PC sends an IGMP report to Switch A to join the appropriate multicast. If the IGMP report matches one of the configured IP multicast group addresses, the switch CPU modifies the hardware address table to include this receiver port and VLAN as a forwarding destination of the specified multicast stream when it is received from the multicast VLAN. Uplink ports that send and receive multicast data to and from the multicast VLAN are called MVR source ports.

When a subscriber changes channels or turns off the television, the set-top box sends an IGMP leave message for the multicast stream. The switch CPU sends a MAC-based general query through the receiver port VLAN. If there is another set-top box in the VLAN still subscribing to this group, that set-top box must respond within the maximum response time specified in the query. If the CPU does not receive a response, it eliminates the receiver port as a forwarding destination for this group.

Without Immediate Leave, when the switch receives an IGMP leave message from a subscriber on a receiver port, it sends out an IGMP query on that port and waits for IGMP group membership reports. If no reports are received in a configured time period, the receiver port is removed from multicast group membership. With Immediate Leave, an IGMP query is not sent from the receiver port on which the IGMP leave was received. As soon as the leave message is received, the receiver port is removed from multicast group membership, which speeds up leave latency. Enable the Immediate-Leave feature only on receiver ports to which a single receiver device is connected.

MVR eliminates the need to duplicate television-channel multicast traffic for subscribers in each VLAN. Multicast traffic for all channels is only sent around the VLAN trunk once—only on the multicast VLAN. The IGMP leave and join messages are in the VLAN to which the subscriber port is assigned. These messages dynamically register for streams of multicast traffic in the multicast VLAN on the Layer 3 device. The access layer switch, Switch A, modifies the forwarding behavior to allow the traffic to be forwarded from the multicast VLAN to the subscriber port in a different VLAN, selectively allowing traffic to cross between two VLANs.

IGMP reports are sent to the same IP multicast group address as the multicast data. The Switch A CPU must capture all IGMP join and leave messages from receiver ports and forward them to the multicast VLAN of the source (uplink) port, based on the MVR mode.

Default MVR Configuration

Table 20: Default MVR Configuration

Feature	Default Setting
MVR	Disabled globally and per interface
Multicast addresses	None configured
Query response time	0.5 second
Multicast VLAN	VLAN 1
Mode	Compatible
Interface (per port) default	Neither a receiver nor a source port
Immediate Leave	Disabled on all ports

IGMP Filtering and Throttling

In some environments, for example, metropolitan or multiple-dwelling unit (MDU) installations, you might want to control the set of multicast groups to which a user on a switch port can belong. You can control the

distribution of multicast services, such as IP/TV, based on some type of subscription or service plan. You might also want to limit the number of multicast groups to which a user on a switch port can belong.

With the IGMP filtering feature, you can filter multicast joins on a per-port basis by configuring IP multicast profiles and associating them with individual switch ports. An IGMP profile can contain one or more multicast groups and specifies whether access to the group is permitted or denied. If an IGMP profile denying access to a multicast group is applied to a switch port, the IGMP join report requesting the stream of IP multicast traffic is dropped, and the port is not allowed to receive IP multicast traffic from that group. If the filtering action permits access to the multicast group, the IGMP report from the port is forwarded for normal processing. You can also set the maximum number of IGMP groups that a Layer 2 interface can join.

IGMP filtering controls only group-specific query and membership reports, including join and leave reports. It does not control general IGMP queries. IGMP filtering has no relationship with the function that directs the forwarding of IP multicast traffic. The filtering feature operates in the same manner whether CGMP or MVR is used to forward the multicast traffic.

IGMP filtering applies only to the dynamic learning of IP multicast group addresses, not static configuration.

With the IGMP throttling feature, you can set the maximum number of IGMP groups that a Layer 2 interface can join. If the maximum number of IGMP groups is set, the IGMP snooping forwarding table contains the maximum number of entries, and the interface receives an IGMP join report, you can configure an interface to drop the IGMP report or to replace the randomly selected multicast entry with the received IGMP report.

**Note**

IGMPv3 join and leave messages are not supported on switches running IGMP filtering.

Related Topics

[Configuring IGMP Profiles](#) , on page 192

[Applying IGMP Profiles](#) , on page 195

[Setting the Maximum Number of IGMP Groups](#) , on page 196

[Configuring the IGMP Throttling Action](#) , on page 198

[Restrictions for IGMP Snooping](#) , on page 158

Default IGMP Filtering and Throttling Configuration

This table displays the default IGMP filtering and throttling configuration for the switch.

Table 21: Default IGMP Filtering Configuration

Feature	Default Setting
IGMP filters	None applied.
IGMP maximum number of IGMP groups	No maximum set. Note When the maximum number of groups is in the forwarding table, the default IGMP throttling action is to deny the IGMP report.
IGMP profiles	None defined.

Feature	Default Setting
IGMP profile action	Deny the range addresses.

How to Configure IGMP Snooping and MVR

Enabling or Disabling IGMP Snooping on a Switch

When IGMP snooping is globally enabled or disabled, it is also enabled or disabled in all existing VLAN interfaces. IGMP snooping is enabled on all VLANs by default, but can be enabled and disabled on a per-VLAN basis.

Global IGMP snooping overrides the VLAN IGMP snooping. If global snooping is disabled, you cannot enable VLAN snooping. If global snooping is enabled, you can enable or disable VLAN snooping.

Follow these steps to globally enable IGMP snooping on the switch:

SUMMARY STEPS

1. `enable`
2. `configure terminal`
3. `ip igmp snooping`
4. `end`
5. `copy running-config startup-config`

DETAILED STEPS

	Command or Action	Purpose
Step 1	<p><code>enable</code></p> <p>Example:</p> <pre>Switch> enable</pre>	Enables privileged EXEC mode. Enter your password if prompted.
Step 2	<p><code>configure terminal</code></p> <p>Example:</p> <pre>Switch# configure terminal</pre>	Enters the global configuration mode.
Step 3	<p><code>ip igmp snooping</code></p> <p>Example:</p> <pre>Switch(config)# ip igmp snooping</pre>	<p>Globally enables IGMP snooping in all existing VLAN interfaces.</p> <p>Note To globally disable IGMP snooping on all VLAN interfaces, use the no ip igmp snooping global configuration command.</p>

	Command or Action	Purpose
Step 4	end Example: Switch(config)# end	Returns to privileged EXEC mode.
Step 5	copy running-config startup-config Example: Switch# copy running-config startup-config	(Optional) Saves your entries in the configuration file.

Related Topics

[Default IGMP Snooping Configuration, on page 164](#)

Enabling or Disabling IGMP Snooping on a VLAN Interface

Follow these steps to enable IGMP snooping on a VLAN interface:

SUMMARY STEPS

1. **enable**
2. **configure terminal**
3. **ip igmp snooping vlan *vlan-id***
4. **end**
5. **copy running-config startup-config**

DETAILED STEPS

	Command or Action	Purpose
Step 1	enable Example: Switch> enable	Enables privileged EXEC mode. Enter your password if prompted.

	Command or Action	Purpose
Step 2	configure terminal Example: Switch# configure terminal	Enters the global configuration mode.
Step 3	ip igmp snooping vlan <i>vlan-id</i> Example: Switch(config)# ip igmp snooping vlan 7	Enables IGMP snooping on the VLAN interface. The VLAN ID range is 1 to 1001 and 1006 to 4094. IGMP snooping must be globally enabled before you can enable VLAN snooping. Note To disable IGMP snooping on a VLAN interface, use the no ip igmp snooping vlan <i>vlan-id</i> global configuration command for the specified VLAN number.
Step 4	end Example: Switch(config)# end	Returns to privileged EXEC mode.
Step 5	copy running-config startup-config Example: Switch# copy running-config startup-config	(Optional) Saves your entries in the configuration file.

Related Topics

[Default IGMP Snooping Configuration, on page 164](#)

Setting the Snooping Method

Multicast-capable router ports are added to the forwarding table for every Layer 2 multicast entry. The switch learns of the ports through one of these methods:

- Snooping on IGMP queries, Protocol-Independent Multicast (PIM) packets, and Distance Vector Multicast Routing Protocol (DVMRP) packets.
- Listening to Cisco Group Management Protocol (CGMP) packets from other routers.
- Statically connecting to a multicast router port using the **ip igmp snooping mrouter** global configuration command.

You can configure the switch either to snoop on IGMP queries and PIM/DVMRP packets or to listen to CGMP self-join or proxy-join packets. By default, the switch snoops on PIM/DVMRP packets on all VLANs. To learn of multicast router ports through only CGMP packets, use the **ip igmp snooping vlan *vlan-id* mrouter**

learn cgmp global configuration command. When this command is entered, the router listens to only CGMP self-join and CGMP proxy-join packets and to no other CGMP packets. To learn of multicast router ports through only PIM-DVMRP packets, use the **ip igmp snooping vlan *vlan-id* mrouter learn pim-dvmrp** global configuration command.

If you want to use CGMP as the learning method and no multicast routers in the VLAN are CGMP proxy-enabled, you must enter the **ip cgmp router-only** command to dynamically access the router.

SUMMARY STEPS

1. **enable**
2. **configure terminal**
3. **ip igmp snooping vlan *vlan-id* mrouter learn {cgmp | pim-dvmrp }**
4. **end**
5. **show ip igmp snooping**
6. **copy running-config startup-config**

DETAILED STEPS

	Command or Action	Purpose
Step 1	enable Example: Switch> enable	Enables privileged EXEC mode. Enter your password if prompted.
Step 2	configure terminal Example: Switch# configure terminal	Enters the global configuration mode.
Step 3	ip igmp snooping vlan <i>vlan-id</i> mrouter learn {cgmp pim-dvmrp } Example: Switch(config)# ip igmp snooping vlan 1 mrouter learn cgmp	Specifies the multicast router learning method: <ul style="list-style-type: none"> • cgmp—Listens for CGMP packets. This method is useful for reducing control traffic. • pim-dvmrp—Snoops on IGMP queries and PIM-DVMRP packets. This is the default. <p>Note To return to the default learning method, use the no ip igmp snooping vlan <i>vlan-id</i> mrouter learn cgmp global configuration command.</p>
Step 4	end Example: Switch(config)# end	Returns to privileged EXEC mode.

	Command or Action	Purpose
Step 5	show ip igmp snooping Example: Switch# <code>show ip igmp snooping</code>	Verifies the configuration.
Step 6	copy running-config startup-config Example: Switch# <code>copy running-config startup-config</code>	(Optional) Saves your entries in the configuration file.

Configuring a Multicast Router Port

Perform these steps to add a multicast router port (enable a static connection to a multicast router) on the switch.



Note

Static connections to multicast routers are supported only on switch ports.

SUMMARY STEPS

1. `enable`
2. `configure terminal`
3. `ip igmp snooping vlan vlan-id mrouter interface interface-id`
4. `end`
5. `show ip igmp snooping mrouter [vlan vlan-id]`
6. `copy running-config startup-config`

DETAILED STEPS

	Command or Action	Purpose
Step 1	enable Example: Switch> <code>enable</code>	Enables privileged EXEC mode. Enter your password if prompted.

	Command or Action	Purpose
Step 2	configure terminal Example: Switch# configure terminal	Enters the global configuration mode.
Step 3	ip igmp snooping vlan <i>vlan-id</i> mrouter interface <i>interface-id</i> Example: Switch(config)# ip igmp snooping vlan 5 mrouter interface gigabitethernet1/0/1	Specifies the multicast router VLAN ID and the interface to the multicast router. <ul style="list-style-type: none"> • The VLAN ID range is 1 to 1001 and 1006 to 4094. • The interface can be a physical interface or a port channel. The port-channel range is 1 to 128. Note To remove a multicast router port from the VLAN, use the no ip igmp snooping vlan <i>vlan-id</i> mrouter interface <i>interface-id</i> global configuration command.
Step 4	end Example: Switch(config)# end	Returns to privileged EXEC mode.
Step 5	show ip igmp snooping mrouter [vlan <i>vlan-id</i>] Example: Switch# show ip igmp snooping mrouter vlan 5	Verifies that IGMP snooping is enabled on the VLAN interface.
Step 6	copy running-config startup-config Example: Switch# copy running-config startup-config	(Optional) Saves your entries in the configuration file.

Related Topics

[Example: Enabling a Static Connection to a Multicast Router, on page 203](#)

Configuring a Host Statically to Join a Group

Hosts or Layer 2 ports normally join multicast groups dynamically, but you can also statically configure a host on an interface.

Follow these steps to add a Layer 2 port as a member of a multicast group:

SUMMARY STEPS

1. **enable**
2. **configure terminal**
3. **ip igmp snooping vlan *vlan-id* static *ip_address* interface *interface-id***
4. **end**
5. **show ip igmp snooping groups**
6. **copy running-config startup-config**

DETAILED STEPS

	Command or Action	Purpose
Step 1	enable Example: Switch> enable	Enables privileged EXEC mode. Enter your password if prompted.
Step 2	configure terminal Example: Switch# configure terminal	Enters the global configuration mode.
Step 3	ip igmp snooping vlan <i>vlan-id</i> static <i>ip_address</i> interface <i>interface-id</i> Example: Switch(config)# ip igmp snooping vlan 105 static 230.0.0.1 interface gigabitethernet1/0/1	Statically configures a Layer 2 port as a member of a multicast group: <ul style="list-style-type: none"> • <i>vlan-id</i> is the multicast group VLAN ID. The range is 1 to 1001 and 1006 to 4094. • <i>ip-address</i> is the group IP address. • <i>interface-id</i> is the member port. It can be a physical interface or a port channel (1 to 128). <p>Note To remove the Layer 2 port from the multicast group, use the no ip igmp snooping vlan <i>vlan-id</i> static <i>mac-address</i> interface <i>interface-id</i> global configuration command.</p>
Step 4	end Example: Switch(config)# end	Returns to privileged EXEC mode.

	Command or Action	Purpose
Step 5	show ip igmp snooping groups Example: Switch# <code>show ip igmp snooping groups</code>	Verifies the member port and the IP address.
Step 6	copy running-config startup-config Example: Switch# <code>copy running-config startup-config</code>	(Optional) Saves your entries in the configuration file.

Related Topics

[Joining a Multicast Group, on page 161](#)

[Example: Configuring a Host Statically to Join a Group, on page 203](#)

Enabling IGMP Immediate Leave

When you enable IGMP Immediate Leave, the switch immediately removes a port when it detects an IGMP Version 2 leave message on that port. You should use the Immediate-Leave feature only when there is a single receiver present on every port in the VLAN.



Note

Immediate Leave is supported only on IGMP Version 2 hosts. IGMP Version 2 is the default version for the switch.

SUMMARY STEPS

1. `enable`
2. `configure terminal`
3. `ip igmp snooping vlan vlan-id immediate-leave`
4. `end`
5. `show ip igmp snooping vlan vlan-id`
6. `end`

DETAILED STEPS

	Command or Action	Purpose
Step 1	enable Example: Switch> enable	Enables privileged EXEC mode. Enter your password if prompted.
Step 2	configure terminal Example: Switch# configure terminal	Enters the global configuration mode.
Step 3	ip igmp snooping vlan <i>vlan-id</i> immediate-leave Example: Switch(config)# ip igmp snooping vlan 21 immediate-leave	Enables IGMP Immediate Leave on the VLAN interface. Note To disable IGMP Immediate Leave on a VLAN, use the no ip igmp snooping vlan <i>vlan-id</i> immediate-leave global configuration command.
Step 4	end Example: Switch(config)# end	Returns to privileged EXEC mode.
Step 5	show ip igmp snooping vlan <i>vlan-id</i> Example: Switch# show ip igmp snooping vlan 21	Verifies that Immediate Leave is enabled on the VLAN interface.
Step 6	end Example: Switch(config)# end	Returns to privileged EXEC mode.

Related Topics

[Immediate Leave](#) , on page 163

[Example: Enabling IGMP Immediate Leave](#), on page 203

Configuring the IGMP Leave Timer

You can configure the leave time globally or on a per-VLAN basis. Follow these steps to enable the IGMP configurable-leave timer:

SUMMARY STEPS

1. `enable`
2. `configure terminal`
3. `ip igmp snooping last-member-query-interval time`
4. `ip igmp snooping vlan vlan-id last-member-query-interval time`
5. `end`
6. `show ip igmp snooping`
7. `copy running-config startup-config`

DETAILED STEPS

	Command or Action	Purpose
Step 1	<p><code>enable</code></p> <p>Example:</p> <pre>Switch> enable</pre>	Enables privileged EXEC mode. Enter your password if prompted.
Step 2	<p><code>configure terminal</code></p> <p>Example:</p> <pre>Switch# configure terminal</pre>	Enters the global configuration mode.
Step 3	<p><code>ip igmp snooping last-member-query-interval time</code></p> <p>Example:</p> <pre>Switch(config)# ip igmp snooping last-member-query-interval 1000</pre>	<p>Configures the IGMP leave timer globally. The range is 100 to 32767 milliseconds.</p> <p>The default leave time is 1000 milliseconds.</p> <p>Note To globally reset the IGMP leave timer to the default setting, use the no ip igmp snooping last-member-query-interval global configuration command.</p>
Step 4	<p><code>ip igmp snooping vlan <i>vlan-id</i> last-member-query-interval time</code></p> <p>Example:</p> <pre>Switch(config)# ip igmp snooping vlan 210</pre>	<p>(Optional) Configures the IGMP leave time on the VLAN interface. The range is 100 to 32767 milliseconds.</p> <p>Note Configuring the leave time on a VLAN overrides the globally configured timer.</p> <p>Note To remove the configured IGMP leave-time setting from the specified VLAN, use the no ip igmp snooping vlan <i>vlan-id</i> last-member-query-interval global configuration command.</p>

	Command or Action	Purpose
	<code>last-member-query-interval 1000</code>	
Step 5	end Example: Switch(config)# <code>end</code>	Returns to privileged EXEC mode.
Step 6	show ip igmp snooping Example: Switch# <code>show ip igmp snooping</code>	(Optional) Displays the configured IGMP leave time.
Step 7	copy running-config startup-config Example: Switch# <code>copy running-config startup-config</code>	(Optional) Saves your entries in the configuration file.

Related Topics

[IGMP Configurable-Leave Timer, on page 163](#)

Configuring TCN-Related Commands

Controlling the Multicast Flooding Time After a TCN Event

You can configure the number of general queries by which multicast data traffic is flooded after a topology change notification (TCN) event. If you set the TCN flood query count to 1 the flooding stops after receiving 1 general query. If you set the count to 7, the flooding continues until 7 general queries are received. Groups are relearned based on the general queries received during the TCN event.

Some examples of TCN events are when the client location is changed and the receiver is on same port that was blocked but is now forwarding, and when a port goes down without sending a leave message.

Follow these steps to configure the TCN flood query count:

SUMMARY STEPS

1. `enable`
2. `configure terminal`
3. `ip igmp snooping tcn flood query count count`
4. `end`
5. `show ip igmp snooping`
6. `copy running-config startup-config`

DETAILED STEPS

	Command or Action	Purpose
Step 1	<p><code>enable</code></p> <p>Example:</p> <pre>Switch> enable</pre>	Enables privileged EXEC mode. Enter your password if prompted.
Step 2	<p><code>configure terminal</code></p> <p>Example:</p> <pre>Switch# configure terminal</pre>	Enters the global configuration mode.
Step 3	<p><code>ip igmp snooping tcn flood query count <i>count</i></code></p> <p>Example:</p> <pre>Switch(config)# ip igmp snooping tcn flood query count 3</pre>	<p>Specifies the number of IGMP general queries for which the multicast traffic is flooded.</p> <p>The range is 1 to 10. The default, the flooding query count is 2.</p> <p>Note To return to the default flooding query count, use the no ip igmp snooping tcn flood query count global configuration command.</p>
Step 4	<p><code>end</code></p> <p>Example:</p> <pre>Switch(config)# end</pre>	Returns to privileged EXEC mode.
Step 5	<p><code>show ip igmp snooping</code></p> <p>Example:</p> <pre>Switch# show ip igmp snooping</pre>	Verifies the TCN settings.

	Command or Action	Purpose
Step 6	copy running-config startup-config Example: Switch# <code>copy running-config startup-config</code>	(Optional) Saves your entries in the configuration file.

Recovering from Flood Mode

When a topology change occurs, the spanning-tree root sends a special IGMP leave message (also known as global leave) with the group multicast address 0.0.0.0. However, you can enable the switch to send the global leave message whether it is the spanning-tree root or not. When the router receives this special leave, it immediately sends general queries, which expedite the process of recovering from the flood mode during the TCN event. Leaves are always sent if the switch is the spanning-tree root regardless of this configuration.

Follow these steps to enable sending of leave messages:

SUMMARY STEPS

1. `enable`
2. `configure terminal`
3. `ip igmp snooping tcn query solicit`
4. `end`
5. `show ip igmp snooping`
6. `copy running-config startup-config`

DETAILED STEPS

	Command or Action	Purpose
Step 1	<code>enable</code> Example: Switch> <code>enable</code>	Enables privileged EXEC mode. Enter your password if prompted.
Step 2	<code>configure terminal</code> Example: Switch# <code>configure terminal</code>	Enters the global configuration mode.

	Command or Action	Purpose
Step 3	ip igmp snooping tcn query solicit Example: Switch(config)# ip igmp snooping tcn query solicit	Sends an IGMP leave message (global leave) to speed the process of recovering from the flood mode caused during a TCN event. By default, query solicitation is disabled. Note To return to the default query solicitation, use the no ip igmp snooping tcn query solicit global configuration command.
Step 4	end Example: Switch(config)# end	Returns to privileged EXEC mode.
Step 5	show ip igmp snooping Example: Switch# show ip igmp snooping	Verifies the TCN settings.
Step 6	copy running-config startup-config Example: Switch# copy running-config startup-config	(Optional) Saves your entries in the configuration file.

Disabling Multicast Flooding During a TCN Event

When the switch receives a TCN, multicast traffic is flooded to all the ports until 2 general queries are received. If the switch has many ports with attached hosts that are subscribed to different multicast groups, this flooding might exceed the capacity of the link and cause packet loss. Follow these steps to control TCN flooding:

SUMMARY STEPS

1. **enable**
2. **configure terminal**
3. **interface *interface-id***
4. **no ip igmp snooping tcn flood**
5. **end**
6. **show ip igmp snooping**
7. **copy running-config startup-config**

DETAILED STEPS

	Command or Action	Purpose
Step 1	<p>enable</p> <p>Example:</p> <pre>Switch> enable</pre>	Enables privileged EXEC mode. Enter your password if prompted.
Step 2	<p>configure terminal</p> <p>Example:</p> <pre>Switch# configure terminal</pre>	Enters the global configuration mode.
Step 3	<p>interface <i>interface-id</i></p> <p>Example:</p> <pre>Switch(config)# interface gigabitethernet 1/0/1</pre>	Specifies the interface to be configured, and enters interface configuration mode.
Step 4	<p>no ip igmp snooping tcn flood</p> <p>Example:</p> <pre>Switch(config-if)# no ip igmp snooping tcn flood</pre>	<p>Disables the flooding of multicast traffic during a spanning-tree TCN event.</p> <p>By default, multicast flooding is enabled on an interface.</p> <p>Note To re-enable multicast flooding on an interface, use the ip igmp snooping tcn flood interface configuration command.</p>
Step 5	<p>end</p> <p>Example:</p> <pre>Switch(config)# end</pre>	Returns to privileged EXEC mode.
Step 6	<p>show ip igmp snooping</p> <p>Example:</p> <pre>Switch# show ip igmp snooping</pre>	Verifies the TCN settings.
Step 7	<p>copy running-config startup-config</p> <p>Example:</p> <pre>Switch# copy running-config startup-config</pre>	(Optional) Saves your entries in the configuration file.

Configuring the IGMP Snooping Querier

Follow these steps to enable the IGMP snooping querier feature in a VLAN:

SUMMARY STEPS

1. `enable`
2. `configure terminal`
3. `ip igmp snooping querier`
4. `ip igmp snooping querier address ip_address`
5. `ip igmp snooping querier query-interval interval-count`
6. `ip igmp snooping querier tcn query [count count | interval interval]`
7. `ip igmp snooping querier timer expiry timeout`
8. `ip igmp snooping querier version version`
9. `end`
10. `show ip igmp snooping vlan vlan-id`
11. `copy running-config startup-config`

DETAILED STEPS

	Command or Action	Purpose
Step 1	<p><code>enable</code></p> <p>Example:</p> <pre>Switch> enable</pre>	Enables privileged EXEC mode. Enter your password if prompted.
Step 2	<p><code>configure terminal</code></p> <p>Example:</p> <pre>Switch# configure terminal</pre>	Enters the global configuration mode.
Step 3	<p><code>ip igmp snooping querier</code></p> <p>Example:</p> <pre>Switch(config)# ip igmp snooping querier</pre>	Enables the IGMP snooping querier.
Step 4	<p><code>ip igmp snooping querier address ip_address</code></p> <p>Example:</p> <pre>Switch(config)# ip igmp snooping querier address 172.16.24.1</pre>	<p>(Optional) Specifies an IP address for the IGMP snooping querier. If you do not specify an IP address, the querier tries to use the global IP address configured for the IGMP querier.</p> <p>Note The IGMP snooping querier does not generate an IGMP general query if it cannot find an IP address on the switch.</p>

	Command or Action	Purpose
Step 5	<p>ip igmp snooping querier query-interval <i>interval-count</i></p> <p>Example:</p> <pre>Switch(config)# ip igmp snooping querier query-interval 30</pre>	(Optional) Sets the interval between IGMP queriers. The range is 1 to 18000 seconds.
Step 6	<p>ip igmp snooping querier tcn query [<i>count count</i> <i>interval interval</i>]</p> <p>Example:</p> <pre>Switch(config)# ip igmp snooping querier tcn query interval 20</pre>	(Optional) Sets the time between Topology Change Notification (TCN) queries. The count range is 1 to 10. The interval range is 1 to 255 seconds.
Step 7	<p>ip igmp snooping querier timer expiry <i>timeout</i></p> <p>Example:</p> <pre>Switch(config)# ip igmp snooping querier timer expiry 180</pre>	(Optional) Sets the length of time until the IGMP querier expires. The range is 60 to 300 seconds.
Step 8	<p>ip igmp snooping querier version <i>version</i></p> <p>Example:</p> <pre>Switch(config)# ip igmp snooping querier version 2</pre>	(Optional) Selects the IGMP version number that the querier feature uses. Select 1 or 2.
Step 9	<p>end</p> <p>Example:</p> <pre>Switch(config)# end</pre>	Returns to privileged EXEC mode.
Step 10	<p>show ip igmp snooping vlan <i>vlan-id</i></p> <p>Example:</p> <pre>Switch# show ip igmp snooping vlan 30</pre>	(Optional) Verifies that the IGMP snooping querier is enabled on the VLAN interface. The VLAN ID range is 1 to 1001 and 1006 to 4094.
Step 11	<p>copy running-config startup-config</p> <p>Example:</p> <pre>Switch# copy running-config startup-config</pre>	(Optional) Saves your entries in the configuration file.

Related Topics

[IGMP Snooping](#), on page 160

[Prerequisites for IGMP Snooping](#), on page 157

[Example: Setting the IGMP Snooping Querier Source Address](#), on page 204

[Example: Setting the IGMP Snooping Querier Maximum Response Time](#), on page 204

[Example: Setting the IGMP Snooping Querier Timeout](#), on page 204

[Example: Setting the IGMP Snooping Querier Feature](#), on page 204

Disabling IGMP Report Suppression

Follow these steps to disable IGMP report suppression:

SUMMARY STEPS

1. `enable`
2. `configure terminal`
3. `no ip igmp snooping report-suppression`
4. `end`
5. `show ip igmp snooping`
6. `copy running-config startup-config`

DETAILED STEPS

	Command or Action	Purpose
Step 1	<p><code>enable</code></p> <p>Example:</p> <pre>Switch> enable</pre>	Enables privileged EXEC mode. Enter your password if prompted.
Step 2	<p><code>configure terminal</code></p> <p>Example:</p> <pre>Switch# configure terminal</pre>	Enters the global configuration mode.
Step 3	<p><code>no ip igmp snooping report-suppression</code></p> <p>Example:</p> <pre>Switch(config)# no ip igmp snooping</pre>	<p>Disables IGMP report suppression. When report suppression is disabled, all IGMP reports are forwarded to the multicast routers.</p> <p>IGMP report suppression is enabled by default.</p> <p>When IGMP report suppression is enabled, the switch forwards only one IGMP report per multicast router query.</p> <p>Note To re-enable IGMP report suppression, use the <code>ip igmp snooping report-suppression</code> global configuration command.</p>

	Command or Action	Purpose
	<code>report-suppression</code>	
Step 4	end Example: Switch(config)# <code>end</code>	Returns to privileged EXEC mode.
Step 5	show ip igmp snooping Example: Switch# <code>show ip igmp snooping</code>	Verifies that IGMP report suppression is disabled.
Step 6	copy running-config startup-config Example: Switch# <code>copy running-config startup-config</code>	(Optional) Saves your entries in the configuration file.

Related Topics

[IGMP Report Suppression, on page 164](#)

Configuring MVR Global Parameters

You do not need to set the optional MVR parameters if you choose to use the default settings. If you want to change the default parameters (except for the MVR VLAN), you must first enable MVR.



Note

For complete syntax and usage information for the commands used in this section, see the command reference for this release.

SUMMARY STEPS

1. **enable**
2. **configure terminal**
3. **mvr**
4. **mvr group ip-address [count]**
5. **mvr querytime value**
6. **mvr vlan vlan-id**
7. **mvr mode {dynamic | compatible}**
8. **end**
9. Use one of the following:
 - **show mvr**
 - **show mvr members**
10. **copy running-config startup-config**

DETAILED STEPS

	Command or Action	Purpose
Step 1	enable Example: Switch> enable	Enables privileged EXEC mode. Enter your password if prompted.
Step 2	configure terminal Example: Switch# configure terminal	Enters the global configuration mode.
Step 3	mvr Example: Switch (config)# mvr	Enables MVR on the switch.
Step 4	mvr group ip-address [count] Example: Switch(config)# mvr group 228.1.23.4	Configures an IP multicast address on the switch or use the <i>count</i> parameter to configure a contiguous series of MVR group addresses (the range for <i>count</i> is 1 to 256; the default is 1). Any multicast data sent to this address is sent to all source ports on the switch and all receiver ports that have elected to receive data on that multicast address. Each multicast address would correspond to one television channel. Note To return the switch to its default settings, use the no mvr [mode group ip-address querytime vlan] global configuration commands.

	Command or Action	Purpose
Step 5	mvr querytime <i>value</i> Example: Switch(config)# mvr querytime 10	(Optional) Defines the maximum time to wait for IGMP report memberships on a receiver port before removing the port from multicast group membership. The value is in units of tenths of a second. The range is 1 to 100, and the default is 5 tenths or one-half second.
Step 6	mvr vlan <i>vlan-id</i> Example: Switch(config)# mvr vlan 22	(Optional) Specifies the VLAN in which multicast data is received; all source ports must belong to this VLAN. The VLAN range is 1 to 1001 and 1006 to 4094. The default is VLAN 1.
Step 7	mvr mode { dynamic compatible } Example: Switch(config)# mvr mode dynamic	(Optional) Specifies the MVR mode of operation: <ul style="list-style-type: none"> • dynamic—Allows dynamic MVR membership on source ports. • compatible—Is compatible with Catalyst 3500 XL and Catalyst 2900 XL switches and does not support IGMP dynamic joins on source ports. The default is compatible mode. Note To return the switch to its default settings, use the no mvr [mode group ip-address querytime vlan] global configuration commands.
Step 8	end Example: Switch(config)# end	Returns to privileged EXEC mode.
Step 9	Use one of the following: <ul style="list-style-type: none"> • show mvr • show mvr members Example: Switch# show mvr OR Switch# show mvr members	Verifies the configuration.
Step 10	copy running-config startup-config Example: Switch# copy running-config	(Optional) Saves your entries in the configuration file.

	Command or Action	Purpose
	<code>startup-config</code>	

Configuring MVR Interfaces

Follow these steps to configure Layer 2 MVR interfaces:

SUMMARY STEPS

1. `enable`
2. `configure terminal`
3. `mvr`
4. `interface interface-id`
5. `mvr type {source | receiver}`
6. `mvr vlan vlan-id group [ip-address]`
7. `mvr immediate`
8. `end`
9. Use one of the following:
 - `show mvr`
 - `show mvr interface`
 - `show mvr members`
10. `copy running-config startup-config`

DETAILED STEPS

	Command or Action	Purpose
Step 1	<code>enable</code> Example: Switch> <code>enable</code>	Enables privileged EXEC mode. Enter your password if prompted.
Step 2	<code>configure terminal</code> Example: Switch# <code>configure terminal</code>	Enters the global configuration mode.

	Command or Action	Purpose
Step 3	mvr Example: Switch (config)# mvr	Enables MVR on the switch.
Step 4	interface interface-id Example: Switch(config)# interface gigabitethernet1/0/2	Specifies the Layer 2 port to configure, and enter interface configuration mode.
Step 5	mvr type {source receiver} Example: Switch(config-if)# mvr type receiver	<p>Configures an MVR port as one of these:</p> <ul style="list-style-type: none"> • source—Configures uplink ports that receive and send multicast data as source ports. Subscribers cannot be directly connected to source ports. All source ports on a switch belong to the single multicast VLAN. • receiver—Configures a port as a receiver port if it is a subscriber port and should only receive multicast data. It does not receive data unless it becomes a member of the multicast group, either statically or by using IGMP leave and join messages. Receiver ports cannot belong to the multicast VLAN. <p>The default configuration is as a non-MVR port. If you attempt to configure a non-MVR port with MVR characteristics, the operation fails.</p> <p>Note To return the interface to its default settings, use the no mvr [type immediate vlan vlan-id group] interface configuration commands.</p>
Step 6	mvr vlan vlan-id group [ip-address] Example: Switch(config-if)# mvr vlan 22 group 228.1.23.4	<p>(Optional) Statically configures a port to receive multicast traffic sent to the multicast VLAN and the IP multicast address. A port statically configured as a member of a group remains a member of the group until statically removed.</p> <p>Note In compatible mode, this command applies to only receiver ports. In dynamic mode, it applies to receiver ports and source ports.</p> <p>Receiver ports can also dynamically join multicast groups by using IGMP join and leave messages.</p>
Step 7	mvr immediate Example: Switch(config-if)# mvr immediate	<p>(Optional) Enables the Immediate-Leave feature of MVR on the port.</p> <p>Note This command applies to only receiver ports and should only be enabled on receiver ports to which a single receiver device is connected.</p>

	Command or Action	Purpose
Step 8	end Example: Switch(config)# end	Returns to privileged EXEC mode.
Step 9	Use one of the following: <ul style="list-style-type: none"> • show mvr • show mvr interface • show mvr members Example: <pre>Switch# show mvr interface Port Type Status ----- Immediate Leave ----- Gi1/0/2 RECEIVER ACTIVE/DOWN ENABLED</pre>	Verifies the configuration.
Step 10	copy running-config startup-config Example: Switch# copy running-config startup-config	(Optional) Saves your entries in the configuration file.

Configuring IGMP Profiles

Follow these steps to create an IGMP profile:

This task is optional.

SUMMARY STEPS

1. **enable**
2. **configure terminal**
3. **ip igmp profile** *profile number*
4. **permit | deny**
5. **range** *ip multicast address*
6. **end**
7. **show ip igmp profile** *profile number*
8. **show running-config**
9. **copy running-config startup-config**

DETAILED STEPS

	Command or Action	Purpose
Step 1	enable Example: Switch> enable	Enables privileged EXEC mode. Enter your password if prompted.
Step 2	configure terminal Example: Switch# configure terminal	Enters the global configuration mode.
Step 3	ip igmp profile <i>profile number</i> Example: Switch(config)# ip igmp profile 3	<p>Assigns a number to the profile you are configuring, and enters IGMP profile configuration mode. The profile number range is 1 to 4294967295. When you are in IGMP profile configuration mode, you can create the profile by using these commands:</p> <ul style="list-style-type: none"> • deny—Specifies that matching addresses are denied; this is the default. • exit—Exits from igmp-profile configuration mode. • no—Negates a command or returns to its defaults. • permit—Specifies that matching addresses are permitted. • range—Specifies a range of IP addresses for the profile. You can enter a single IP address or a range with a start and an end address. <p>The default is for the switch to have no IGMP profiles configured.</p> <p>Note To delete a profile, use the no ip igmp profile <i>profile number</i> global configuration command.</p>

	Command or Action	Purpose
Step 4	permit deny Example: Switch(config-igmp-profile)# permit	(Optional) Sets the action to permit or deny access to the IP multicast address. If no action is configured, the default for the profile is to deny access.
Step 5	range ip multicast address Example: Switch(config-igmp-profile)# range 229.9.9.0	Enters the IP multicast address or range of IP multicast addresses to which access is being controlled. If entering a range, enter the low IP multicast address, a space, and the high IP multicast address. You can use the range command multiple times to enter multiple addresses or ranges of addresses. Note To delete an IP multicast address or range of IP multicast addresses, use the no range ip multicast address IGMP profile configuration command.
Step 6	end Example: Switch(config)# end	Returns to privileged EXEC mode.
Step 7	show ip igmp profile profile number Example: Switch# show ip igmp profile 3	Verifies the profile configuration.
Step 8	show running-config Example: Switch# show running-config	Verifies your entries.
Step 9	copy running-config startup-config Example: Switch# copy running-config startup-config	(Optional) Saves your entries in the configuration file.

Related Topics

[IGMP Filtering and Throttling, on page 167](#)

[Restrictions for IGMP Snooping, on page 158](#)

Applying IGMP Profiles

To control access as defined in an IGMP profile, you have to apply the profile to the appropriate interfaces. You can apply IGMP profiles only to Layer 2 access ports; you cannot apply IGMP profiles to routed ports or SVIs. You cannot apply profiles to ports that belong to an EtherChannel port group. You can apply a profile to multiple interfaces, but each interface can have only one profile applied to it.

Follow these steps to apply an IGMP profile to a switch port:

SUMMARY STEPS

1. **enable**
2. **configure terminal**
3. **interface** *interface-id*
4. **ip igmp filter** *profile number*
5. **end**
6. **show running-config**
7. **copy running-config startup-config**

DETAILED STEPS

	Command or Action	Purpose
Step 1	enable Example: Switch> enable	Enables privileged EXEC mode. Enter your password if prompted.
Step 2	configure terminal Example: Switch# configure terminal	Enters the global configuration mode.
Step 3	interface <i>interface-id</i> Example: Switch(config)# interface gigabitethernet1/0/1	Specifies the physical interface, and enters interface configuration mode. The interface must be a Layer 2 port that does not belong to an EtherChannel port group.
Step 4	ip igmp filter <i>profile number</i> Example: Switch(config-if)# ip igmp filter 321	Applies the specified IGMP profile to the interface. The range is 1 to 4294967295. Note To remove a profile from an interface, use the no ip igmp filter <i>profile number</i> interface configuration command.

	Command or Action	Purpose
Step 5	end Example: Switch(config-if)# end	Returns to privileged EXEC mode.
Step 6	show running-config Example: Switch# show running-config	Verifies your entries.
Step 7	copy running-config startup-config Example: Switch# copy running-config startup-config	(Optional) Saves your entries in the configuration file.

Related Topics

[IGMP Filtering and Throttling, on page 167](#)

[Restrictions for IGMP Snooping, on page 158](#)

Setting the Maximum Number of IGMP Groups

Follow these steps to set the maximum number of IGMP groups that a Layer 2 interface can join:

Before You Begin

This restriction can be applied to Layer 2 ports only; you cannot set a maximum number of IGMP groups on routed ports or SVIs. You also can use this command on a logical EtherChannel interface but cannot use it on ports that belong to an EtherChannel port group.

SUMMARY STEPS

1. **enable**
2. **configure terminal**
3. **interface** *interface-id*
4. **ip igmp max-groups** *number*
5. **end**
6. **show running-config interface** *interface-id*
7. **copy running-config startup-config**

DETAILED STEPS

	Command or Action	Purpose
Step 1	<p>enable</p> <p>Example:</p> <pre>Switch> enable</pre>	Enables privileged EXEC mode. Enter your password if prompted.
Step 2	<p>configure terminal</p> <p>Example:</p> <pre>Switch# configure terminal</pre>	Enters the global configuration mode.
Step 3	<p>interface <i>interface-id</i></p> <p>Example:</p> <pre>Switch(config)# interface gigabitethernet1/0/2</pre>	Specifies the interface to be configured, and enters interface configuration mode. The interface can be a Layer 2 port that does not belong to an EtherChannel group or a EtherChannel interface.
Step 4	<p>ip igmp max-groups <i>number</i></p> <p>Example:</p> <pre>Switch(config-if)# ip igmp max-groups 20</pre>	<p>Sets the maximum number of IGMP groups that the interface can join. The range is 0 to 4294967294. The default is to have no maximum set.</p> <p>Note To remove the maximum group limitation and return to the default of no maximum, use the no ip igmp max-groups interface configuration command.</p>
Step 5	<p>end</p> <p>Example:</p> <pre>Switch(config)# end</pre>	Returns to privileged EXEC mode.
Step 6	<p>show running-config interface <i>interface-id</i></p> <p>Example:</p> <pre>Switch# show running-config interface gigabitethernet1/0/1</pre>	Verifies your entries.
Step 7	<p>copy running-config startup-config</p> <p>Example:</p> <pre>Switch# copy running-config startup-config</pre>	(Optional) Saves your entries in the configuration file.

Related Topics[IGMP Filtering and Throttling, on page 167](#)[Restrictions for IGMP Snooping, on page 158](#)

Configuring the IGMP Throttling Action

After you set the maximum number of IGMP groups that a Layer 2 interface can join, you can configure an interface to replace the existing group with the new group for which the IGMP report was received.

Follow these steps to configure the throttling action when the maximum number of entries is in the forwarding table:

SUMMARY STEPS

1. **enable**
2. **configure terminal**
3. **interface *interface-id***
4. **ip igmp max-groups action {deny | replace}**
5. **end**
6. **show running-config interface *interface-id***
7. **copy running-config startup-config**

DETAILED STEPS

	Command or Action	Purpose
Step 1	enable Example: <pre>Switch> enable</pre>	Enables privileged EXEC mode. Enter your password if prompted.
Step 2	configure terminal Example: <pre>Switch# configure terminal</pre>	Enters the global configuration mode.
Step 3	interface <i>interface-id</i> Example: <pre>Switch(config)# interface gigabitethernet 1/0/1</pre>	Specifies the physical interface to be configured, and enters interface configuration mode. The interface can be a Layer 2 port that does not belong to an EtherChannel group or an EtherChannel interface. The interface cannot be a trunk port.
Step 4	ip igmp max-groups action {deny replace}	When an interface receives an IGMP report and the maximum number of entries is in the forwarding table, specifies the action that the interface takes:

	Command or Action	Purpose
	<p>Example:</p> <pre>Switch(config-if)# ip igmp max-groups action replace</pre>	<ul style="list-style-type: none"> • deny—Drops the report. If you configure this throttling action, the entries that were previously in the forwarding table are not removed but are aged out. After these entries are aged out and the maximum number of entries is in the forwarding table, the switch drops the next IGMP report received on the interface. • replace—Replaces the existing group with the new group for which the IGMP report was received. If you configure this throttling action, the entries that were previously in the forwarding table are removed. When the maximum number of entries is in the forwarding table, the switch replaces a randomly selected entry with the received IGMP report. <p>To prevent the switch from removing the forwarding-table entries, you can configure the IGMP throttling action before an interface adds entries to the forwarding table.</p> <p>Note To return to the default action of dropping the report, use the no ip igmp max-groups action interface configuration command.</p>
Step 5	<p>end</p> <p>Example:</p> <pre>Switch(config)# end</pre>	Returns to privileged EXEC mode.
Step 6	<p>show running-config interface <i>interface-id</i></p> <p>Example:</p> <pre>Switch# show running-config interface gigabitethernet1/0/1</pre>	Verifies your entries.
Step 7	<p>copy running-config startup-config</p> <p>Example:</p> <pre>Switch# copy running-config startup-config</pre>	(Optional) Saves your entries in the configuration file.

Related Topics

[IGMP Filtering and Throttling, on page 167](#)

[Restrictions for IGMP Snooping, on page 158](#)

Monitoring IGMP Snooping and MVR

Monitoring IGMP Snooping Information

You can display IGMP snooping information for dynamically learned and statically configured router ports and VLAN interfaces. You can also display MAC address multicast entries for a VLAN configured for IGMP snooping.

Table 22: Commands for Displaying IGMP Snooping Information

Command	Purpose
	Displays the snooping configuration information for all VLANs on the switch or for a specified VLAN. (Optional) Enter vlan <i>vlan-id</i> to display information for a single VLAN. The VLAN ID range is 1 to 1001 and 1006 to 4094.
show ip igmp snooping groups [count dynamic [count] user [count]]	Displays multicast table information for the switch or about a specific parameter: <ul style="list-style-type: none"> • count—Displays the total number of entries for the specified command options instead of the actual entries. • dynamic—Displays entries learned through IGMP snooping. • user—Displays only the user-configured multicast entries.
show ip igmp snooping groups vlan <i>vlan-id</i> [<i>ip_address</i> count dynamic [count] user [count]]	Displays multicast table information for a multicast VLAN or about a specific parameter for the VLAN: <ul style="list-style-type: none"> • <i>vlan-id</i>—The VLAN ID range is 1 to 1001 and 1006 to 4094. • count—Displays the total number of entries for the specified command options instead of the actual entries. • dynamic—Displays entries learned through IGMP snooping. • <i>ip_address</i>—Displays characteristics of the multicast group with the specified group IP address. • user—Displays only the user-configured multicast entries.

Command	Purpose
show ip igmp snooping mrouter [<i>vlan vlan-id</i>]	Displays information on dynamically learned and manually configured multicast router interfaces. Note When you enable IGMP snooping, the switch automatically learns the interface to which a multicast router is connected. These are dynamically learned interfaces. (Optional) Enter the vlan <i>vlan-id</i> to display information for a particular VLAN.
show ip igmp snooping querier [<i>vlan vlan-id</i>]	Display information about the IP address and receiving port for the most-recently received IGMP query messages in the VLAN. (Optional) Enter <i>vlan vlan-id</i> to display information for a single VLAN.
show ip igmp snooping querier [<i>vlan vlan-id</i>] detail	Displays information about the IP address and receiving port of the most-recently received IGMP query message in the VLAN and the configuration and operational state of the IGMP snooping querier in the VLAN.

Monitoring MVR

You can monitor MVR for the switch or for a specified interface by displaying the following MVR information.

Table 23: Commands for Displaying MVR Information

Command	Purpose
show mvr	Displays MVR status and values for the switch—whether MVR is enabled or disabled, the multicast VLAN, the maximum (256) and current (0 through 256) number of multicast groups, the query response time, and the MVR mode.

Command	Purpose
show mvr interface [<i>interface-id</i>] [members [vlan <i>vlan-id</i>]]	<p>Displays all MVR interfaces and their MVR configurations.</p> <p>When a specific interface is entered, displays this information:</p> <ul style="list-style-type: none"> • Type—Receiver or Source • Status—One of these: <ul style="list-style-type: none"> ◦ Active means the port is part of a VLAN. ◦ Up/Down means that the port is forwarding or nonforwarding. ◦ Inactive means that the port is not part of any VLAN. • Immediate Leave—Enabled or Disabled <p>If the members keyword is entered, displays all multicast group members on this port or, if a VLAN identification is entered, all multicast group members on the VLAN. The VLAN ID range is 1 to 1001 and 1006 to 4094.</p>
show mvr members [<i>ip-address</i>]	Displays all receiver and source ports that are members of any IP multicast group or the specified IP multicast group IP address.

Monitoring IGMP Filtering and Throttling Configuration

You can display IGMP profile characteristics, and you can display the IGMP profile and maximum group configuration for all interfaces on the switch or for a specified interface. You can also display the IGMP throttling configuration for all interfaces on the switch or for a specified interface.

Table 24: Commands for Displaying IGMP Filtering and Throttling Configuration

Command	Purpose
show ip igmp profile [<i>profile number</i>]	Displays the specified IGMP profile or all the IGMP profiles defined on the switch.
show running-config [interface <i>interface-id</i>]	Displays the configuration of the specified interface or the configuration of all interfaces on the switch, including (if configured) the maximum number of IGMP groups to which an interface can belong and the IGMP profile applied to the interface.

Configuration Examples for IGMP Snooping and MVR

Example: Configuring IGMP Snooping Using CGMP Packets

This example shows how to configure IGMP snooping to use CGMP packets as the learning method:

```
Switch# configure terminal
Switch(config)# ip igmp snooping vlan 1 mrouter learn cgmp
Switch(config)# end
```

Example: Enabling a Static Connection to a Multicast Router

This example shows how to enable a static connection to a multicast router:

```
Switch configure terminal
Switch ip igmp snooping vlan 200 mrouter interface gigabitethernet1/0/2
Switch end
```

Related Topics

[Configuring a Multicast Router Port](#) , on page 173

Example: Configuring a Host Statically to Join a Group

This example shows how to statically configure a host on a port:

```
Switch# configure terminal
Switch# ip igmp snooping vlan 105 static 224.2.4.12 interface gigabitethernet1/0/1
Switch# end
```

Related Topics

[Configuring a Host Statically to Join a Group](#) , on page 174

[Joining a Multicast Group](#) , on page 161

Example: Enabling IGMP Immediate Leave

This example shows how to enable IGMP Immediate Leave on VLAN 130:

```
Switch# configure terminal
Switch(config)# ip igmp snooping vlan 130 immediate-leave
Switch(config)# end
```

Related Topics

[Enabling IGMP Immediate Leave](#) , on page 176

[Immediate Leave](#) , on page 163

Example: Setting the IGMP Snooping Querier Source Address

This example shows how to set the IGMP snooping querier source address to 10.0.0.64:

```
Switch# configure terminal  
Switch(config)# ip igmp snooping querier 10.0.0.64  
Switch(config)# end
```

Related Topics

[Configuring the IGMP Snooping Querier](#) , on page 184

[IGMP Snooping](#), on page 160

Example: Setting the IGMP Snooping Querier Maximum Response Time

This example shows how to set the IGMP snooping querier maximum response time to 25 seconds:

```
Switch# configure terminal  
Switch(config)# ip igmp snooping querier query-interval 25  
Switch(config)# end
```

Related Topics

[Configuring the IGMP Snooping Querier](#) , on page 184

[IGMP Snooping](#), on page 160

Example: Setting the IGMP Snooping Querier Timeout

This example shows how to set the IGMP snooping querier timeout to 60 seconds:

```
Switch# configure terminal  
Switch(config)# ip igmp snooping querier timeout expiry 60  
Switch(config)# end
```

Related Topics

[Configuring the IGMP Snooping Querier](#) , on page 184

[IGMP Snooping](#), on page 160

Example: Setting the IGMP Snooping Querier Feature

This example shows how to set the IGMP snooping querier feature to Version 2:

```
Switch# configure terminal  
Switch(config)# no ip igmp snooping querier version 2  
Switch(config)# end
```

Related Topics

[Configuring the IGMP Snooping Querier](#) , on page 184

[IGMP Snooping](#), on page 160

Example: Configuring IGMP Profiles

This example shows how to create IGMP profile 4 allowing access to the single IP multicast address and how to verify the configuration. If the action was to deny (the default), it would not appear in the **show ip igmp profile** output display.

```
Switch(config)# ip igmp profile 4
Switch(config-igmp-profile)# permit
Switch(config-igmp-profile)# range 229.9.9.0
Switch(config-igmp-profile)# end
Switch# show ip igmp profile 4
IGMP Profile 4
    permit
    range 229.9.9.0 229.9.9.0
```

Example: Applying IGMP Profile

This example shows how to apply IGMP profile 4 to a port:

```
Switch(config)# interface gigabitethernet1/0/2
Switch(config-if)# ip igmp filter 4
Switch(config-if)# end
```

Example: Setting the Maximum Number of IGMP Groups

This example shows how to limit to 25 the number of IGMP groups that a port can join:

```
Switch(config)# interface gigabitethernet1/0/2
Switch(config-if)# ip igmp max-groups 25
Switch(config-if)# end
```

Example: Configuring MVR Global Parameters

This example shows how to enable MVR, configure the group address, set the query time to 1 second (10 tenths), specify the MVR multicast VLAN as VLAN 22, and set the MVR mode as dynamic:

```
Switch(config)# mvr
Switch(config)# mvr group 228.1.23.4
Switch(config)# mvr querytime 10
Switch(config)# mvr vlan 22
Switch(config)# mvr mode dynamic
Switch(config)# end
```

Example: Configuring MVR Interfaces

This example shows how to configure a port as a receiver port, statically configure the port to receive multicast traffic sent to the multicast group address, configure Immediate Leave on the port, and verify the results:

```
Switch(config)# mvr
Switch(config)# interface gigabitethernet1/0/2
Switch(config-if)# mvr type receiver
Switch(config-if)# mvr vlan 22 group 228.1.23.4
Switch(config-if)# mvr immediate
Switch(config-if)# end
Switch# show mvr interface
```

```
Port Type Status Immediate Leave
-----
Gi1/0/2 RECEIVER ACTIVE/DOWN ENABLED
```

Additional References

Related Documents

Related Topic	Document Title
For complete syntax and usage information for the commands used in this chapter.	<i>Command Reference, Cisco Release 15.2(2)E(Industrial Ethernet 3000 Switch)</i> ,
Cisco IOS commands	Cisco IOS Master Commands List, All Releases

Standards and RFCs

Standard/RFC	Title
RFC 1112	<i>Host Extensions for IP Multicasting</i>
RFC 2236	<i>Internet Group Management Protocol, Version 2</i>

MIBs

MIB	MIBs Link
All supported MIBs for this release.	To locate and download MIBs for selected platforms, Cisco IOS releases, and feature sets, use Cisco MIB Locator found at the following URL: http://www.cisco.com/go/mibs

Technical Assistance

Description	Link
<p>The Cisco Support website provides extensive online resources, including documentation and tools for troubleshooting and resolving technical issues with Cisco products and technologies.</p> <p>To receive security and technical information about your products, you can subscribe to various services, such as the Product Alert Tool (accessed from Field Notices), the Cisco Technical Services Newsletter, and Really Simple Syndication (RSS) Feeds.</p> <p>Access to most tools on the Cisco Support website requires a Cisco.com user ID and password.</p>	<p>http://www.cisco.com/support</p>



Configuring MSDP

- [Finding Feature Information](#), page 209
- [, page 209](#)
- [Information About Multicast Source Discovery Protocol](#), page 209
- [How to Configure MSDP](#), page 217
- [Monitoring and Maintaining MSDP](#), page 236
- [Configuration Examples for Configuring MSDP](#), page 239
- [Additional References](#), page 241

Finding Feature Information

Your software release may not support all the features documented in this module. For the latest caveats and feature information, see [Bug Search Tool](#) and the release notes for your platform and software release. To find information about the features documented in this module, and to see a list of the releases in which each feature is supported, see the feature information table at the end of this module.

Use Cisco Feature Navigator to find information about platform support and Cisco software image support. To access Cisco Feature Navigator, go to www.cisco.com/go/cfn. An account on Cisco.com is not required.

Information About Multicast Source Discovery Protocol

MSDP is a mechanism to connect multiple PIM-SM domains. The purpose of MSDP is to discover multicast sources in other PIM domains. The main advantage of MSDP is that it reduces the complexity of interconnecting multiple PIM-SM domains by allowing PIM-SM domains to use an interdomain source tree (rather than a common shared tree). When MSDP is configured in a network, RPs exchange source information with RPs in other domains. An RP can join the interdomain source tree for sources that are sending to groups for which it has receivers. The RP can do that because it is the root of the shared tree within its domain, which has branches to all points in the domain where there are active receivers. When a last-hop device learns of a new

source outside the PIM-SM domain (through the arrival of a multicast packet from the source down the shared tree), it then can send a join toward the source and join the interdomain source tree.

**Note**

If the RP either has no shared tree for a particular group or a shared tree whose outgoing interface list is null, it does not send a join to the source in another domain.

When MSDP is enabled, an RP in a PIM-SM domain maintains MSDP peering relationships with MSDP-enabled devices in other domains. This peering relationship occurs over a TCP connection, where primarily a list of sources sending to multicast groups is exchanged. MSDP uses TCP (port 639) for its peering connections. As with BGP, using point-to-point TCP peering means that each peer must be explicitly configured. The TCP connections between RPs, moreover, are achieved by the underlying routing system. The receiving RP uses the source lists to establish a source path. If the multicast sources are of interest to a domain that has receivers, multicast data is delivered over the normal, source-tree building mechanism provided by PIM-SM. MSDP is also used to announce sources sending to a group. These announcements must originate at the RP of the domain.

The figure illustrates MSDP operating between two MSDP peers. PIM uses MSDP as the standard mechanism to register a source with the RP of a domain.

Figure 11: MSDP Running Between RP Peers

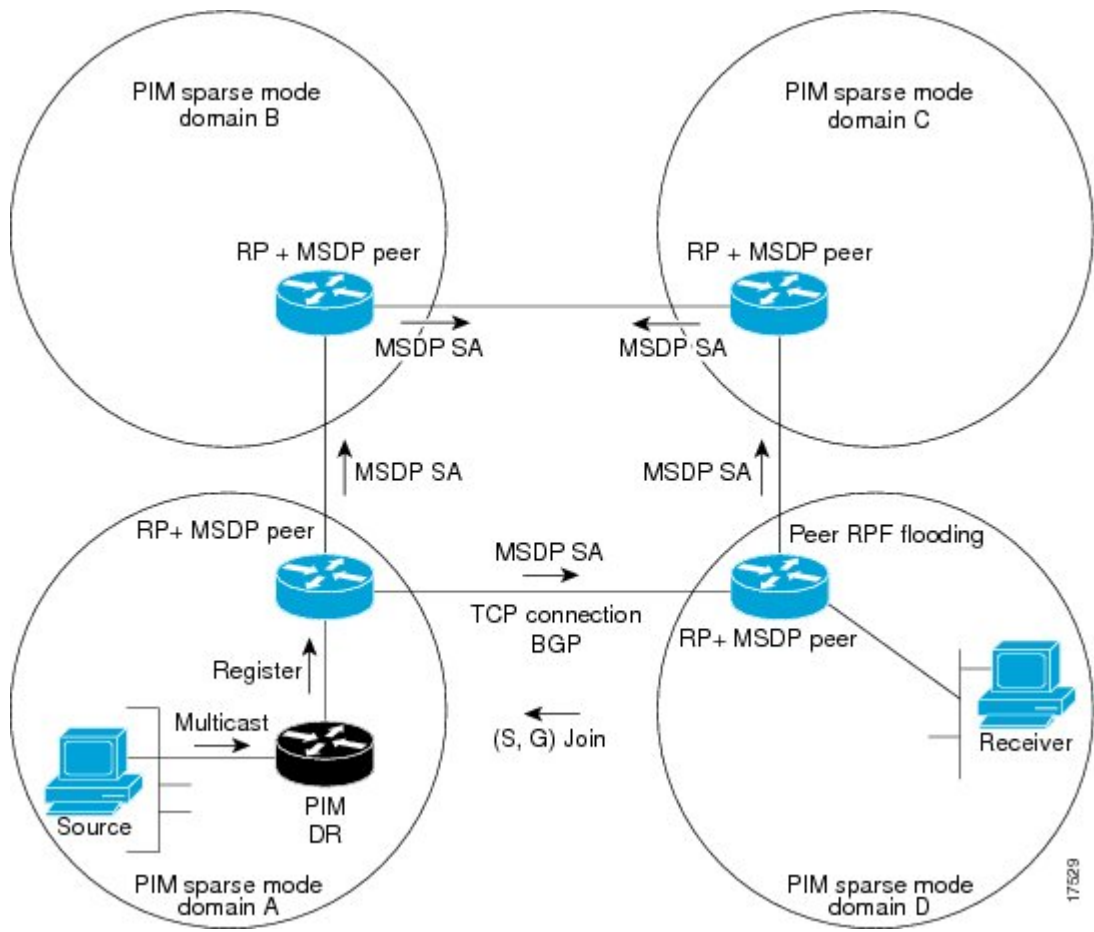

When MSDP is implemented, the following sequence of events occurs:

- 1 When a PIM designated device (DR) registers a source with its RP as illustrated in the figure, the RP sends a Source-Active (SA) message to all of its MSDP peers.

Note

The DR sends the encapsulated data to the RP only once per source (when the source goes active). If the source times out, this process happens again when it goes active again. This situation is different from the periodic SA message that contains all sources that are registered to the originating RP. Those SA messages are MSDP control packets, and, thus, do not contain encapsulated data from active sources.

- 1 The SA message identifies the source address, the group that the source is sending to, and the address or the originator ID of the RP, if configured.
- 2 Each MSDP peer that receives the SA message floods the SA message to all of its peers downstream from the originator. In some cases (such as the case with the RPs in PIM-SM domains B and C in the figure), an RP may receive a copy of an SA message from more than one MSDP peer. To prevent looping, the RP consults the BGP next-hop database to determine the next hop toward the originator of the SA message. If both MBGP and unicast BGP are configured, MBGP is checked first, and then unicast BGP. That next-hop neighbor is the RPF-peer for the originator. SA messages that are received from the originator on any interface other than the interface to the RPF peer are dropped. The SA message flooding process, therefore, is referred to as peer-RPF flooding. Because of the peer-RPF flooding mechanism, BGP or MBGP must be running in conjunction with MSDP.
- 1 When an RP receives an SA message, it checks to see whether there are any members of the advertised groups in its domain by checking to see whether there are interfaces on the group's (*, G) outgoing interface list. If there are no group members, the RP does nothing. If there are group members, the RP sends an (S, G) join toward the source. As a result, a branch of the interdomain source tree is constructed across autonomous system boundaries to the RP. As multicast packets arrive at the RP, they are then forwarded down its own shared tree to the group members in the RP's domain. The members' DRs then have the option of joining the rendezvous point tree (RPT) to the source using standard PIM-SM procedures.
- 2 The originating RP continues to send periodic SA messages for the (S, G) state every 60 seconds for as long as the source is sending packets to the group. When an RP receives an SA message, it caches the SA message. Suppose, for example, that an RP receives an SA message for (172.16.5.4, 228.1.2.3) from originating RP 10.5.4.3. The RP consults its mroute table and finds that there are no active members for group 228.1.2.3, so it passes the SA message to its peers downstream of 10.5.4.3. If a host in the domain then sends a join to the RP for group 228.1.2.3, the RP adds the interface toward the host to the outgoing interface list of its (*, 228.1.2.3) entry. Because the RP caches SA messages, the device will have an entry for (172.16.5.4, 228.1.2.3) and can join the source tree as soon as a host requests a join.

Note

In all current and supported software releases, caching of MSDP SA messages is mandatory and cannot be manually enabled or disabled. By default, when an MSDP peer is configured, the **ip multicast cache-sa-state** command will automatically be added to the running configuration.

MSDP Benefits

MSDP has these benefits:

- It breaks up the shared multicast distribution tree. You can make the shared tree local to your domain. Your local members join the local tree, and join messages for the shared tree never need to leave your domain.
- PIM sparse-mode domains can rely only on their own RPs, decreasing reliance on RPs in another domain. This increases security because you can prevent your sources from being known outside your domain.
- Domains with only receivers can receive data without globally advertising group membership.
- Global source multicast routing table state is not required, saving memory.

Default MSDP Peers

A stub autonomous system also might want to have MSDP peerings with more than one RP for the sake of redundancy. For example, SA messages cannot just be accepted from multiple default peers, because there is no RPF check mechanism. Instead, SA messages are accepted from only one peer. If that peer fails, SA messages are then accepted from the other peer. The underlying assumption here, of course, is that both default peers are sending the same SA messages.

The figure illustrates a scenario where default MSDP peers might be used. In the figure, a customer that owns Device B is connected to the Internet through two Internet service providers (ISPs), one that owns Device A and the other that owns Device C. They are not running BGP or MBGP between them. In order for the customer to learn about sources in the ISP domain or in other domains, Device B identifies Device A as its default MSDP peer. Device B advertises SA messages to both Device A and Device C, but accepts SA messages either from Device A only or Device C only. If Device A is the first default peer in the configuration, it will be used if it is up and running. Only if Device A is not running will Device B accept SA messages from Device C.

The ISP will also likely use a prefix list to define which prefixes it will accept from the customer device. The customer will define multiple default peers, each having one or more prefixes associated with it.

The customer has two ISPs to use. The customer defines both ISPs as default peers. As long as the first default peer identified in the configuration is up and running, it will be the default peer and the customer will accept all SA messages it receives from that peer.

Figure 12: Default MSDP Peer Scenario

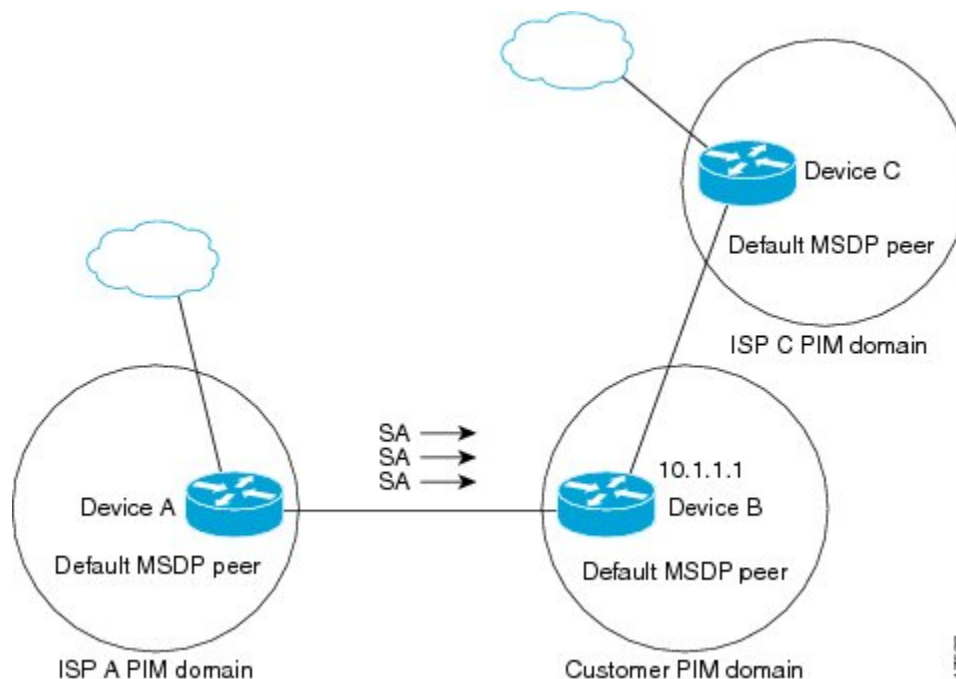

Device B advertises SAs to Device A and Device C, but uses only Device A or Device C to accept SA messages. If Device A is first in the configuration, it will be used if it is up and running. Only when Device A is not running will Device B accept SAs from Device C. This is the behavior without a prefix list.

If you specify a prefix list, the peer will be a default peer only for the prefixes in the list. You can have multiple active default peers when you have a prefix list associated with each. When you do not have any prefix lists, you can configure multiple default peers, but only the first one is the active default peer as long as the device has connectivity to this peer and the peer is alive. If the first configured peer goes down or the connectivity to this peer goes down, the second configured peer becomes the active default, and so on.

MSDP Mesh Groups

An MSDP mesh group is a group of MSDP speakers that have fully meshed MSDP connectivity between one another. In other words, each of the MSDP peers in the group must have an MSDP peering relationship (MSDP connection) to every other MSDP peer in the group. When an MSDP mesh group is configured between a group of MSDP peers, SA message flooding is reduced. Because when an MSDP peer in the group receives an SA message from another MSDP peer in the group, it assumes that this SA message was sent to all the other MSDP peers in the group. As a result, it is not necessary for the receiving MSDP peer to flood the SA message to the other MSDP peers in the group.

Benefits of MSDP Mesh Groups

- Optimizes SA flooding--MSDP mesh groups are particularly useful for optimizing SA flooding when two or more peers are in a group.
- Reduces the amount of SA traffic across the Internet--When MSDP mesh groups are used, SA messages are not flooded to other mesh group peers.
- Eliminates RPF checks on arriving SA messages--When an MSDP mesh group is configured, SA messages are always accepted from mesh group peers.

SA Origination Filters

By default, an RP that is configured to run MSDP will originate SA messages for all local sources for which it is the RP. Local sources that register with an RP, therefore, will be advertised in SA messages, which in some cases is not desirable. For example, if sources inside a PIM-SM domain are using private addresses (for example, network 10.0.0.0/8), you should configure an SA origination filter to restrict those addresses from being advertised to other MSDP peers across the Internet.

To control what sources are advertised in SA messages, you can configure SA origination filters on an RP. By creating SA origination filters, you can control the sources advertised in SA messages as follows:

- You can configure an RP to prevent the device from advertising local sources in SA messages. The device will still forward SA messages from other MSDP peers in the normal fashion; it will just not originate any SA messages for local sources.
- You can configure the device to only originate SA messages for local sources sending to specific groups that match (S, G) pairs defined in the extended access list. All other local sources will not be advertised in SA messages.
- You can configure the device to only originate SA messages for local sources sending to specific groups that the match AS paths defined in an AS-path access list. All other local sources will not be advertised in SA messages.
- You can configure the device to only originate SA messages for local sources that match the criteria defined in the route map. All other local sources will not be advertised in SA messages.
- You configure an SA origination filter that includes an extended access list, an AS-path access list, and route map, or a combination thereof. In this case, all conditions must be true before any local sources are advertised in SA messages.

Use of Outgoing Filter Lists in MSDP

By default, an MSDP-enabled device forwards all SA messages it receives to all of its MSDP peers. However, you can prevent SA messages from being forwarded to MSDP peers by creating outgoing filter lists. Outgoing filter lists apply to all SA messages, whether locally originated or received from another MSDP peer, whereas SA origination filters apply only to locally originated SA messages. For more information about enabling a filter for MSDP SA messages originated by the local device, see the [Controlling SA Messages Originated by an RP for Local Sources](#) section.

By creating an outgoing filter list, you can control the SA messages that a device forwards to a peer as follows:

- You can filter all outgoing SA messages forwarded to a specified MSDP peer by configuring the device to stop forwarding its SA messages to the MSDP peer.
- You can filter a subset of outgoing SA messages forwarded to a specified MSDP peer based on (S, G) pairs defined in an extended access list by configuring the device to only forward SA messages to the MSDP peer that match the (S, G) pairs permitted in an extended access list. The forwarding of all other SA messages to the MSDP peer will be stopped.
- You can filter a subset of outgoing SA messages forwarded to a specified MSDP peer based on match criteria defined in a route map by configuring the device to only forward SA messages that match the criteria defined in the route map. The forwarding of all other SA messages to the MSDP peer will be stopped.
- You can filter a subset of outgoing SA messages from a specified peer based on the announcing RP address contained in the SA message by configuring the device to filter outgoing SA messages based on their origin, even after an SA message has been transmitted across one or more MSDP peers. The forwarding of all other SA messages to the MSDP peer will be stopped.
- You can configure an outgoing filter list that includes an extended access list, a route map, and either an RP access list or an RP route map. In this case, all conditions must be true for the MSDP peer to forward the outgoing SA message.

**Caution**

Arbitrary filtering of SA messages can result in downstream MSDP peers being starved of SA messages for legitimate active sources. Care, therefore, should be taken when using these sorts of filters. Normally, outgoing filter lists are used only to reject undesirable sources, such as sources using private addresses.

Use of Incoming Filter Lists in MSDP

By default, an MSDP-enabled device receives all SA messages sent to it from its MSDP peers. However, you can control the source information that a device receives from its MSDP peers by creating incoming filter lists.

By creating incoming filter lists, you can control the incoming SA messages that a device receives from its peers as follows:

- You can filter all incoming SA messages from a specified MSDP peer by configuring the device to ignore all SA messages sent to it from the specified MSDP peer.
- You can filter a subset of incoming SA messages from a specified peer based on (S, G) pairs defined in an extended access list by configuring the device to only receive SA messages from the MSDP peer that match the (S, G) pairs defined in the extended access list. All other incoming SA messages from the MSDP peer will be ignored.
- You can filter a subset of incoming SA request messages from a specified peer based on match criteria defined in a route map by configuring the device to only receive SA messages that match the criteria defined in the route map. All other incoming SA messages from the MSDP peer will be ignored.
- You can filter a subset of incoming SA messages from a specified peer based on both (S, G) pairs defined in an extended access list and on match criteria defined in a route map by configuring the device to only receive incoming SA messages that both match the (S, G) pairs defined in the extended access list and match the criteria defined in the route map. All other incoming SA messages from the MSDP peer will be ignored.

- You can filter a subset of incoming SA messages from a specified peer based on the announcing RP address contained in the SA message by configuring the device to filter incoming SA messages based on their origin, even after the SA message may have already been transmitted across one or more MSDP peers.
- You can configure an incoming filter list that includes an extended access list, a route map, and either an RP access list or an RP route map. In this case, all conditions must be true for the MSDP peer to receive the incoming SA message.

**Caution**

Arbitrary filtering of SA messages can result in downstream MSDP peers being starved of SA messages for legitimate active sources. Care, therefore, should be taken when using these sorts of filters. Normally, incoming filter lists are used only to reject undesirable sources, such as sources using private addresses.

TTL Thresholds in MSDP

The time-to-live (TTL) value provides a means to limit the number of hops a packet can take before being dropped. The **ip multicast ttl-threshold** command is used to specify a TTL for data-encapsulated SA messages sent to specified MSDP peers. By default, multicast data packets in SA messages are sent to an MSDP peer, provided the TTL value of the packet is greater than 0, which is standard TTL behavior.

In general, a TTL-threshold problem can be introduced by the encapsulation of a source's initial multicast packet in an SA message. Because the multicast packet is encapsulated inside of the unicast SA message (whose TTL is 255), its TTL is not decremented as the SA message travels to the MSDP peer. Furthermore, the total number of hops that the SA message traverses can be drastically different than a normal multicast packet because multicast and unicast traffic may follow completely different paths to the MSDP peer and hence the remote PIM-SM domain. As a result, encapsulated packets can end up violating TTL thresholds. The solution to this problem is to configure a TTL threshold that is associated with any multicast packet that is encapsulated in an SA message sent to a particular MSDP peer using the **ip multicast ttl-threshold** command. The **ip msdp ttl-threshold** command prevents any multicast packet whose TTL in the IP header is less than the TTL value specified for the *ttl-value* argument from being encapsulated in SA messages sent to that peer.

MSDP Message Types

There are four basic MSDP message types, each encoded in their own Type, Length, and Value (TLV) data format.

SA Messages

SA messages are used to advertise active sources in a domain. In addition, these SA messages may contain the initial multicast data packet that was sent by the source.

SA messages contain the IP address of the originating RP and one or more (S, G) pairs being advertised. In addition, the SA message may contain an encapsulated data packet.

SA Request Messages

SA request messages are used to request a list of active sources for a specific group. These messages are sent to an MSDP SA cache that maintains a list of active (S, G) pairs in its SA cache. Join latency can be reduced by using SA request messages to request the list of active sources for a group instead of having to wait up to 60 seconds for all active sources in the group to be readvertised by originating RPs.

SA Response Messages

SA response messages are sent by the MSDP peer in response to an SA request message. SA response messages contain the IP address of the originating RP and one or more (S, G) pairs of the active sources in the originating RP's domain that are stored in the cache.

Keepalive Messages

Keepalive messages are sent every 60 seconds in order to keep the MSDP session active. If no keepalive messages or SA messages are received for 75 seconds, the MSDP session is reset.

Default MSDP Configuration

MSDP is not enabled, and no default MSDP peer exists.

How to Configure MSDP

Configuring a Default MSDP Peer

Before You Begin

Configure an MSDP peer.

DETAILED STEPS

	Command or Action	Purpose
Step 1	<p>configure terminal</p> <p>Example:</p> <pre>Router# configure terminal</pre>	Enters global configuration mode.
Step 2	<p>ip msdp default-peer <i>ip-address</i> <i>name</i> [<i>prefix-list list</i>]</p> <p>Example:</p> <pre>Router(config)# ip msdp default-peer</pre>	<p>Defines a default peer from which to accept all MSDP SA messages.</p> <ul style="list-style-type: none"> For <i>ip-address</i> <i>name</i>, enter the IP address or Domain Name System (DNS) server name of the MSDP default peer.

	Command or Action	Purpose
	<pre>10.1.1.1 prefix-list site-a</pre>	<ul style="list-style-type: none"> (Optional) For prefix-list list, enter the list name that specifies the peer to be the default peer only for the listed prefixes. You can have multiple active default peers when you have a prefix list associated with each. <p>When you enter multiple ip msdp default-peer commands with the prefix-list keyword, you use all the default peers at the same time for different RP prefixes. This syntax is typically used in a service provider cloud that connects stub site clouds.</p> <p>When you enter multiple ip msdp default-peer commands without the prefix-list keyword, a single active peer accepts all SA messages. If that peer fails, the next configured default peer accepts all SA messages. This syntax is typically used at a stub site.</p>
Step 3	<p>ip prefix-list <i>name</i> [description string] seq number {permit deny} <i>network length</i></p> <p>Example:</p> <pre>Router(config)# prefix-list site-a seq 3 permit 12 network length 128</pre>	<p>(Optional) Creates a prefix list using the name specified in Step 2.</p> <ul style="list-style-type: none"> (Optional) For description string, enter a description of up to 80 characters to describe this prefix list. For seq number, enter the sequence number of the entry. The range is 1 to 4294967294. The deny keyword denies access to matching conditions. The permit keyword permits access to matching conditions. For network length, specify the network number and length (in bits) of the network mask that is permitted or denied.
Step 4	<p>ip msdp description {<i>peer-name</i> <i>peer-address</i>} <i>text</i></p> <p>Example:</p> <pre>Router(config)# ip msdp description peer-name site-b</pre>	<p>(Optional) Configures a description for the specified peer to make it easier to identify in a configuration or in show command output.</p> <p>By default, no description is associated with an MSDP peer.</p>
Step 5	<p>end</p> <p>Example:</p> <pre>Router(config)# end</pre>	<p>Returns to privileged EXEC mode.</p>
Step 6	<p>show running-config</p> <p>Example:</p> <pre>Router# show running-config</pre>	<p>Verifies your entries.</p>

	Command or Action	Purpose
Step 7	copy running-config startup-config Example: <pre>Router# copy running-config startup-config</pre>	(Optional) Saves your entries in the configuration file.

Caching Source-Active State

If you want to sacrifice some memory in exchange for reducing the latency of the source information, you can configure the switch to cache SA messages. Perform the following steps to enable the caching of source/group pairs:

This procedure is optional.

DETAILED STEPS

	Command or Action	Purpose
Step 1		
Step 2	configure terminal Example: <pre>Switch# configure terminal</pre>	Enters global configuration mode.
Step 3	ip msdp cache-sa-state [list access-list-number] Example: <pre>Switch(config)# ip msdp cache-sa-state 100</pre>	<p>Enables the caching of source/group pairs (create an SA state). Those pairs that pass the access list are cached.</p> <p>For list access-list-number, the range is 100 to 199.</p> <p>Note An alternative to this command is the ip msdp sa-reques global configuration command, which causes the switch to send an SA request message to the MSDP peer when a new member for a group becomes active.</p>
Step 4	access-list access-list-number {deny permit} protocol source source-wildcard destination destination-wildcard Example: <pre>Switch(config)# access-list 100 permit ip 171.69.0.0 0.0.255.255 224.2.0.0 0.0.255.255</pre>	<p>Creates an IP extended access list, repeating the command as many times as necessary.</p> <ul style="list-style-type: none"> • For access-list-number, the range is 100 to 199. Enter the same number created in Step 2. • The deny keyword denies access if the conditions are matched. The permit keyword permits access if the conditions are matched. • For protocol, enter ip as the protocol name.

	Command or Action	Purpose
		<ul style="list-style-type: none"> • For <i>source</i>, enter the number of the network or host from which the packet is being sent. • For <i>source-wildcard</i>, enter the wildcard bits in dotted decimal notation to be applied to the source. Place ones in the bit positions that you want to ignore. • For <i>destination</i>, enter the number of the network or host to which the packet is being sent. • For <i>destination-wildcard</i>, enter the wildcard bits in dotted decimal notation to be applied to the destination. Place ones in the bit positions that you want to ignore. <p>Recall that the access list is always terminated by an implicit deny statement for everything.</p>
Step 5	end Example: <pre>Switch(config)# end</pre>	Returns to privileged EXEC mode.
Step 6	show running-config Example: <pre>Switch# show running-config</pre>	Verifies your entries.
Step 7	copy running-config startup-config Example: <pre>Switch# copy running-config startup-config</pre>	(Optional) Saves your entries in the configuration file.

Requesting Source Information from an MSDP Peer

If you want a new member of a group to learn the active multicast sources in a connected PIM sparse-mode domain that are sending to a group, perform this task for the switch to send SA request messages to the specified MSDP peer when a new member joins a group. The peer replies with the information in its SA cache. If the peer does not have a cache configured, this command has no result. Configuring this feature reduces join latency but sacrifices memory.

This task is optional.

DETAILED STEPS

	Command or Action	Purpose
Step 1	configure terminal Example: Switch# configure terminal	Enters global configuration mode.
Step 2	ip msdp sa-request { <i>ip-address</i> <i>name</i> } Example: Switch(config)# ip msdp sa-request 171.69.1.1	Configure the switch to send SA request messages to the specified MSDP peer. For <i>ip-address</i> <i>name</i> , enter the IP address or name of the MSDP peer from which the local switch requests SA messages when a new member for a group becomes active. Repeat the command for each MSDP peer that you want to supply with SA messages.
Step 3	end Example: Switch(config)# end	Returns to privileged EXEC mode.
Step 4	show running-config Example: Switch# show running-config	Verifies your entries.
Step 5	copy running-config startup-config Example: Switch# copy running-config startup-config	(Optional) Saves your entries in the configuration file.

Controlling Source Information that Your Switch Originates

You can control the multicast source information that originates with your switch:

- Sources you advertise (based on your sources)
- Receivers of source information (based on knowing the requestor)

For more information, see the [Redistributing Sources](#), on page 222 and the [Filtering Source-Active Request Messages](#), on page 223.

Redistributing Sources

SA messages originate on RPs to which sources have registered. By default, any source that registers with an RP is advertised. The *A flag* is set in the RP when a source is registered, which means the source is advertised in an SA unless it is filtered.

This task is optional.

DETAILED STEPS

	Command or Action	Purpose
Step 1	<p>configure terminal</p> <p>Example:</p> <pre>Switch# configure terminal</pre>	Enters global configuration mode.
Step 2	<p>ip msdp redistribute [<i>list access-list-name</i>] [<i>asn aspath-access-list-number</i>] [<i>route-map map</i>]</p> <p>Example:</p> <pre>Switch(config)# ip msdp redistribute list 21</pre>	<p>Configures which (S,G) entries from the multicast routing table are advertised in SA messages.</p> <p>By default, only sources within the local domain are advertised.</p> <ul style="list-style-type: none"> • (Optional) list <i>access-list-name</i>— Enters the name or number of an IP standard or extended access list. The range is 1 to 99 for standard access lists and 100 to 199 for extended lists. The access list controls which local sources are advertised and to which groups they send. • (Optional) asn <i>aspath-access-list-number</i>—Enters the IP standard or extended access list number in the range 1 to 199. This access list number must also be configured in the ip as-path access-list command. • (Optional) route-map <i>map</i>—Enters the IP standard or extended access list number in the range 1 to 199. This access list number must also be configured in the ip as-path access-list command. <p>The switch advertises (S,G) pairs according to the access list or autonomous system path access list.</p>
Step 3	<p>Use one of the following:</p> <ul style="list-style-type: none"> • access-list<i>access-list-number</i> {deny permit} <i>source</i> [<i>source-wildcard</i>] • access-list<i>access-list-number</i> {deny permit} <i>protocol source source-wildcard destination destination-wildcard</i> 	<p>Creates an IP standard access list, repeating the command as many times as necessary.</p> <p>or</p> <p>Creates an IP extended access list, repeating the command as many times as necessary.</p> <ul style="list-style-type: none"> • <i>access-list-number</i>—Enters the same number created in Step 2. The range is 1 to 99 for standard access lists and 100 to 199 for extended lists. • deny—Denies access if the conditions are matched. The permit keyword permits access if the conditions are matched.

	Command or Action	Purpose
	<p>Example: Switch(config)# access list 21 permit 194.1.22.0</p> <p>OR</p> <p>Switch(config)# access list 21 permit ip 194.1.22.0 1.1.1.1 194.3.44.0 1.1.1.1</p>	<ul style="list-style-type: none"> • <i>protocol</i>—Enters ip as the protocol name. • <i>source</i>—Enters the number of the network or host from which the packet is being sent. • <i>source-wildcard</i>—Enters the wildcard bits in dotted decimal notation to be applied to the source. Place ones in the bit positions that you want to ignore. • <i>destination</i>—Enters the number of the network or host to which the packet is being sent. • <i>destination-wildcard</i>—Enters the wildcard bits in dotted decimal notation to be applied to the destination. Place ones in the bit positions that you want to ignore. <p>Recall that the access list is always terminated by an implicit deny statement for everything.</p>
Step 4	<p>end</p> <p>Example: Switch(config)# end</p>	Returns to privileged EXEC mode.
Step 5	<p>show running-config</p> <p>Example: Switch# show running-config</p>	Verifies your entries.
Step 6	<p>copy running-config startup-config</p> <p>Example: Switch# copy running-config startup-config</p>	(Optional) Saves your entries in the configuration file.

Filtering Source-Active Request Messages

By default, only switches that are caching SA information can respond to SA requests. By default, such a switch honors all SA request messages from its MSDP peers and supplies the IP addresses of the active sources.

However, you can configure the switch to ignore all SA requests from an MSDP peer. You can also honor only those SA request messages from a peer for groups described by a standard access list. If the groups in the access list pass, SA request messages are accepted. All other such messages from the peer for other groups are ignored.

This task is optional.

DETAILED STEPS

	Command or Action	Purpose
Step 1	<p>configure terminal</p> <p>Example:</p> <pre>Switch# configure terminal</pre>	Enters global configuration mode.
Step 2	<p>Use one of the following:</p> <ul style="list-style-type: none"> • ip msdp filter-sa-request <i>{ip-address name}</i> • ip msdp filter-sa-request <i>{ip-address name}</i> list <i>access-list-number</i> <p>Example:</p> <pre>Switch(config)# ip msdp filter sa-request 171.69.2.2</pre>	<p>Filters all SA request messages from the specified MSDP peer.</p> <p>or</p> <p>Filters SA request messages from the specified MSDP peer for groups that pass the standard access list. The access list describes a multicast group address. The range for the access-list-number is 1 to 99.</p>
Step 3	<p>access-list <i>access-list-number</i> {deny permit} <i>source</i> [<i>source-wildcard</i>]</p> <p>Example:</p> <pre>Switch(config)# access-list 1 permit 192.4.22.0 0.0.0.255</pre>	<p>Creates an IP standard access list, repeating the command as many times as necessary.</p> <ul style="list-style-type: none"> • For <i>access-list-number</i>, the range is 1 to 99. • The deny keyword denies access if the conditions are matched. The permit keyword permits access if the conditions are matched. • For <i>source</i>, enter the number of the network or host from which the packet is being sent. • (Optional) For <i>source-wildcard</i>, enter the wildcard bits in dotted decimal notation to be applied to the source. Place ones in the bit positions that you want to ignore. <p>Recall that the access list is always terminated by an implicit deny statement for everything.</p>
Step 4	<p>end</p> <p>Example:</p> <pre>Switch(config)# end</pre>	Returns to privileged EXEC mode.

	Command or Action	Purpose
Step 5	show running-config Example: Switch# <code>show running-config</code>	Verifies your entries.
Step 6	copy running-config startup-config Example: Switch# <code>copy running-config startup-config</code>	(Optional) Saves your entries in the configuration file.

Controlling Source Information that Your Switch Forwards

By default, the switch forwards all SA messages it receives to all its MSDP peers. However, you can prevent outgoing messages from being forwarded to a peer by using a filter or by setting a time-to-live (TTL) value.

Using a Filter

By creating a filter, you can perform one of these actions:

- Filter all source/group pairs
- Specify an IP extended access list to pass only certain source/group pairs
- Filter based on match criteria in a route map

This task is optional.

DETAILED STEPS

	Command or Action	Purpose
Step 1	configure terminal Example: Switch# <code>configure terminal</code>	Enters global configuration mode.
Step 2	Use one of the following: <ul style="list-style-type: none"> • ip msdp sa-filter out <i>{ip-address name}</i> 	<ul style="list-style-type: none"> • Filters all SA messages to the specified MSDP peer. • Passes only those SA messages that pass the IP extended access list to the specified peer. The range for the extended <i>access-list-number</i> is 100 to 199.

	Command or Action	Purpose
	<ul style="list-style-type: none"> • ip msdp sa-filter out <code>{ip-address name}</code> list access-list-number • ip msdp sa-filter out <code>{ip-address name}</code> route-map map-tag <p>Example: Switch(config)# ip msdp sa-filter out switch.cisco.com</p> <p>OR</p> Switch(config)# ip msdp sa-filter out list 100 <p>OR</p> Switch(config)# ip msdp sa-filter out switch.cisco.com route-map 22	<p>If both the list and the route-map keywords are used, all conditions must be true to pass any (S,G) pair in outgoing SA messages.</p> <ul style="list-style-type: none"> • Passes only those SA messages that meet the match criteria in the route map <i>map-tag</i> to the specified MSDP peer. <p>If all match criteria are true, a permit from the route map passes routes through the filter. A deny filters routes.</p>
Step 3	<p>access-list <i>access-list-number</i> {deny permit} <i>protocol source source-wildcard destination destination-wildcard</i></p> <p>Example: Switch(config)# access list 100 permit ip 194.1.22.0 1.1.1.1 194.3.44.0 1.1.1.1</p>	<p>(Optional) Creates an IP extended access list, repeating the command as many times as necessary.</p> <ul style="list-style-type: none"> • For <i>access-list-number</i>, enter the number specified in Step 2. • The deny keyword denies access if the conditions are matched. The permit keyword permits access if the conditions are matched. • For <i>protocol</i>, enter ip as the protocol name. • For <i>source</i>, enter the number of the network or host from which the packet is being sent. • For <i>source-wildcard</i>, enter the wildcard bits in dotted decimal notation to be applied to the source. Place ones in the bit positions that you want to ignore. • For <i>destination</i>, enter the number of the network or host to which the packet is being sent. • For <i>destination-wildcard</i>, enter the wildcard bits in dotted decimal notation to be applied to the destination. Place ones in the bit positions that you want to ignore. <p>Recall that the access list is always terminated by an implicit deny statement for everything.</p>

	Command or Action	Purpose
Step 4	end Example: Switch(config)# end	Returns to privileged EXEC mode.
Step 5	show running-config Example: Switch# show running-config	Verifies your entries.
Step 6	copy running-config startup-config Example: Switch# copy running-config startup-config	(Optional) Saves your entries in the configuration file.

Using TTL to Limit the Multicast Data Sent in SA Messages

You can use a TTL value to control what data is encapsulated in the first SA message for every source. Only multicast packets with an IP-header TTL greater than or equal to the *tll* argument are sent to the specified MSDP peer. For example, you can limit internal traffic to a TTL of 8. If you want other groups to go to external locations, you must send those packets with a TTL greater than 8.

This task is optional.

DETAILED STEPS

	Command or Action	Purpose
Step 1	configure terminal Example: Switch# configure terminal	Enters global configuration mode.
Step 2	ip msdp ttl-threshold <i>{ip-address name} tll</i> Example: Switch(config)# ip msdp ttl-threshold switch.cisco.com 0	Limits which multicast data is encapsulated in the first SA message to the specified MSDP peer. <ul style="list-style-type: none"> For <i>ip-address name</i>, enter the IP address or name of the MSDP peer to which the TTL limitation applies. For <i>tll</i>, enter the TTL value. The default is 0, which means all multicast data packets are forwarded to the peer until the TTL is exhausted. The range is 0 to 255.

	Command or Action	Purpose
Step 3	end Example: Switch(config)# end	Returns to privileged EXEC mode.
Step 4	show running-config Example: Switch# show running-config	Verifies your entries.
Step 5	copy running-config startup-config Example: Switch# copy running-config startup-config	(Optional) Saves your entries in the configuration file.

Controlling Source Information that Your Switch Receives

By default, the switch receives all SA messages that its MSDP RPF peers send to it. However, you can control the source information that you receive from MSDP peers by filtering incoming SA messages. In other words, you can configure the switch to not accept them.

You can perform one of these actions:

- Filter all incoming SA messages from an MSDP peer
- Specify an IP extended access list to pass certain source/group pairs
- Filter based on match criteria in a route map

This task is optional.

DETAILED STEPS

	Command or Action	Purpose
Step 1	configure terminal Example: Switch# configure terminal	Enters global configuration mode.
Step 2	Use one of the following:	<ul style="list-style-type: none"> • Filters all SA messages to the specified MSDP peer.

	Command or Action	Purpose
	<ul style="list-style-type: none"> • ip msdp sa-filter in <i>{ip-address name}</i> • ip msdp sa-filter in <i>{ip-address name}</i> list <i>access-list-number</i> • ip msdp sa-filter in <i>{ip-address name}</i> route-map <i>map-tag</i> <p>Example: Switch(config)# ip msdp sa-filter in switch.cisco.com</p> <p>OR</p> <p>Switch(config)# ip msdp sa-filter in list 100</p> <p>OR</p> <p>Switch(config)# ip msdp sa-filter in switch.cisco.com route-map 22</p>	<ul style="list-style-type: none"> • Passes only those SA messages from the specified peer that pass the IP extended access list. The range for the extended <i>access-list-number</i> is 100 to 199. If both the list and the route-map keywords are used, all conditions must be true to pass any (S,G) pair in outgoing SA messages. • Passes only those SA messages from the specified MSDP peer that meet the match criteria in the route map <i>map-tag</i>. If all match criteria are true, a permit from the route map passes routes through the filter. A deny filters routes.
Step 3	<p>access-list <i>access-list-number</i> {deny permit} <i>protocol source source-wildcard destination</i> <i>destination-wildcard</i></p> <p>Example: Switch(config)# access list 100 permit ip 194.1.22.0 1.1.1.1 194.3.44.0 1.1.1.1</p>	<p>(Optional) Creates an IP extended access list, repeating the command as many times as necessary.</p> <ul style="list-style-type: none"> • <i>access-list-number</i>, enter the number specified in Step 2. • The deny keyword denies access if the conditions are matched. The permit keyword permits access if the conditions are matched. • For <i>protocol</i>, enter ip as the protocol name. • For <i>source</i>, enter the number of the network or host from which the packet is being sent. • For <i>source-wildcard</i>, enter the wildcard bits in dotted decimal notation to be applied to the source. Place ones in the bit positions that you want to ignore. • For <i>destination</i>, enter the number of the network or host to which the packet is being sent. • For <i>destination-wildcard</i>, enter the wildcard bits in dotted decimal notation to be applied to the destination. Place ones in the bit positions that you want to ignore.

	Command or Action	Purpose
		Recall that the access list is always terminated by an implicit deny statement for everything.
Step 4	end Example: Switch(config)# end	Returns to privileged EXEC mode.
Step 5	show running-config Example: Switch# show running-config	Verifies your entries.
Step 6	copy running-config startup-config Example: Switch# copy running-config startup-config	(Optional) Saves your entries in the configuration file.

Configuring an MSDP Mesh Group

Perform this optional task to configure an MSDP mesh group.



Note You can configure multiple mesh groups per device.

SUMMARY STEPS

1. **enable**
2. **configure terminal**
3. **ip msdp mesh-group** *mesh-name* {*peer-address* | *peer-name*}
4. Repeat Step 3 to add MSDP peers as members of the mesh group.
5. **exit**
6. **show running-config**
7. **copy running-config startup-config**

DETAILED STEPS

	Command or Action	Purpose
Step 1	enable Example: Switch> enable	Enables privileged EXEC mode. <ul style="list-style-type: none"> • Enter your password if prompted.
Step 2	configure terminal Example: Switch# configure terminal	Enters global configuration mode.
Step 3	ip msdp mesh-group <i>mesh-name</i> { <i>peer-address</i> <i>peer-name</i> } Example: Switch(config)# ip msdp mesh-group peermesh	Configures an MSDP mesh group and indicates that an MSDP peer belongs to that mesh group. Note All MSDP peers on a device that participate in a mesh group must be fully meshed with all other MSDP peers in the group. Each MSDP peer on each device must be configured as a peer using the ip msdp peer command and also as a member of the mesh group using the ip msdp mesh-group command.
Step 4	Repeat Step 3 to add MSDP peers as members of the mesh group.	--
Step 5	exit Example: Switch(config)# exit	Exits global configuration mode and returns to privileged EXEC mode.
Step 6	show running-config Example: Switch# show running-config	Verifies your entries.
Step 7	copy running-config startup-config Example: Switch# copy running-config startup-config	(Optional) Saves your entries in the configuration file.

Shutting Down an MSDP Peer

Perform this optional task to shut down an MSDP peer.

If you are configuring several MSDP peers and you do not want any of the peers to go active until you have finished configuring all of them, you can shut down each peer, configure each peer, and later bring each peer up. You might also want to shut down an MSDP session without losing the configuration for that MSDP peer.

**Note**

When an MSDP peer is shut down, the TCP connection is terminated and not restarted until the peer is brought back up using the **no ip msdp shutdown** command (for the specified peer).

Before You Begin

MSDP is running and the MSDP peers must be configured.

SUMMARY STEPS

1. **enable**
2. **configure terminal**
3. **ip msdp shutdown** *{peer-name | peer-address}*
4. Repeat Step 3 to shut down additional MSDP peers.
5. **end**
6. **show running-config**
7. **copy running-config startup-config**

DETAILED STEPS

	Command or Action	Purpose
Step 1	enable Example: Switch> enable	Enables privileged EXEC mode. • Enter your password if prompted.
Step 2	configure terminal Example: Switch# configure terminal	Enters global configuration mode.
Step 3	ip msdp shutdown <i>{peer-name peer-address}</i> Example: Switch(config)# ip msdp shutdown 192.168.1.3	Administratively shuts down the specified MSDP peer.
Step 4	Repeat Step 3 to shut down additional MSDP peers.	--
Step 5	end Example: Switch(config)# end	Exits global configuration mode and returns to privileged EXEC mode.

	Command or Action	Purpose
Step 6	show running-config Example: Switch# show running-config	Verifies your entries.
Step 7	copy running-config startup-config Example: Switch# copy running-config startup-config	(Optional) Saves your entries in the configuration file.

Including a Bordering PIM Dense-Mode Region in MSDP

You can configure MSDP on a switch that borders a PIM sparse-mode region with a dense-mode region. By default, active sources in the dense-mode region do not participate in MSDP.



Note We do not recommend using the **ip msdp border sa-address** global configuration command. It is better to configure the border router in the sparse-mode domain to proxy-register sources in the dense-mode domain to the RP of the sparse-mode domain and have the sparse-mode domain use standard MSDP procedures to advertise these sources.

The **ip msdp originator-id** global configuration command also identifies an interface to be used as the RP address. If both the **ip msdp border sa-address** and the **ip msdp originator-id** global configuration commands are configured, the address derived from the **ip msdp originator-id** command specifies the RP address.

This task is optional.

DETAILED STEPS

	Command or Action	Purpose
Step 1	configure terminal Example: Switch# configure terminal	Enters global configuration mode.
Step 2	ip msdp border sa-address interface-id Example: Switch(config)# ip msdp border sa-address 0/1	Configures the switch on the border between a dense-mode and sparse-mode region to send SA messages about active sources in the dense-mode region. For <i>interface-id</i> , specifies the interface from which the IP address is derived and used as the RP address in SA messages.

	Command or Action	Purpose
		The IP address of the interface is used as the Originator-ID, which is the RP field in the SA message.
Step 3	ip msdp redistribute [<i>list access-list-name</i>] [<i>asn aspath-access-list-number</i>] [<i>route-map map</i>] Example: Switch(config)# ip msdp redistribute list 100	Configures which (S,G) entries from the multicast routing table are advertised in SA messages. For more information, see the Redistributing Sources , on page 222.
Step 4	end Example: Switch(config)# end	Returns to privileged EXEC mode.
Step 5	show running-config Example: Switch# show running-config	Verifies your entries.
Step 6	copy running-config startup-config Example: Switch# copy running-config startup-config	(Optional) Saves your entries in the configuration file.

Configuring an Originating Address other than the RP Address

Perform this optional task to allow an MSDP speaker that originates an SA message to use the IP address of its interface as the RP address in the SA message.

You can also change the originator ID for any one of the following reasons:

- If you configure multiple devices in an MSDP mesh group for Anycast RP.
- If you have a device that borders a PIM-SM domain and a PIM-DM domain. If a device borders a PIM-SM domain and a PIM-DM domain and you want to advertise active sources within the PIM-DM domain, configure the RP address in SA messages to be the address of the originating device's interface.

Before You Begin

MSDP is enabled and the MSDP peers are configured. For more information about configuring MSDP peers, see the [Configuring an MSDP Peer](#) section.

SUMMARY STEPS

1. **enable**
2. **configure terminal**
3. **ip msdp originator-id**
4. **exit**
5. **show running-config**
6. **copy running-config startup-config**

DETAILED STEPS

	Command or Action	Purpose
Step 1	enable Example: Switch> enable	Enables privileged EXEC mode. <ul style="list-style-type: none"> • Enter your password if prompted.
Step 2	configure terminal Example: Switch# configure terminal	Enters global configuration mode.
Step 3	ip msdp originator-id Example: Switch(config)# ip msdp originator-id ethernet 1	Configures the RP address in SA messages to be the address of the originating device's interface.
Step 4	exit Example: Switch(config)# exit	Exits global configuration mode and returns to privileged EXEC mode.
Step 5	show running-config Example: Switch# show running-config	Verifies your entries.
Step 6	copy running-config startup-config Example: Switch# copy running-config startup-config	(Optional) Saves your entries in the configuration file.

Monitoring and Maintaining MSDP

Monitoring MSDP

Perform this optional task to monitor MSDP SA messages, peers, state, and peer status.

SUMMARY STEPS

1. **enable**
2. **debug ip msdp** [*peer-address* | *peer-name*] [**detail**] [**routes**]
3. **debug ip msdp resets**
4. **show ip msdp count** [*as-number*]
5. **show ip msdp peer** [*peer-address* | *peer-name*]
6. **show ip msdp sa-cache** [*group-address* | *source-address* | *group-name* | *source-name*] [*as-number*]
7. **show ip msdp summary**

DETAILED STEPS

Step 1 **enable**

Example:

```
Device# enable
```

Enables privileged EXEC mode.

- Enter your password if prompted.

Step 2 **debug ip msdp** [*peer-address* | *peer-name*] [**detail**] [**routes**]

Use this command to debug MSDP activity.

Use the optional *peer-address* or *peer-name* argument to specify for which peer debug events are logged.

The following is sample output from the **debug ip msdp** command:

Example:

```
Device# debug ip msdp
MSDP debugging is on
Device#
MSDP: 224.150.44.254: Received 1388-byte message from peer
MSDP: 224.150.44.254: SA TLV, len: 1388, ec: 115, RP: 172.31.3.92
MSDP: 224.150.44.254: Peer RPF check passed for 172.31.3.92, used EMBGP peer
MSDP: 224.150.44.250: Forward 1388-byte SA to peer
MSDP: 224.150.44.254: Received 1028-byte message from peer
MSDP: 224.150.44.254: SA TLV, len: 1028, ec: 85, RP: 172.31.3.92
MSDP: 224.150.44.254: Peer RPF check passed for 172.31.3.92, used EMBGP peer
MSDP: 224.150.44.250: Forward 1028-byte SA to peer
MSDP: 224.150.44.254: Received 1388-byte message from peer
MSDP: 224.150.44.254: SA TLV, len: 1388, ec: 115, RP: 172.31.3.111
MSDP: 224.150.44.254: Peer RPF check passed for 172.31.3.111, used EMBGP peer
MSDP: 224.150.44.250: Forward 1388-byte SA to peer
```

```

MSDP: 224.150.44.250: Received 56-byte message from peer
MSDP: 224.150.44.250: SA TLV, len: 56, ec: 4, RP: 192.168.76.241
MSDP: 224.150.44.250: Peer RPF check passed for 192.168.76.241, used EMBGP peer
MSDP: 224.150.44.254: Forward 56-byte SA to peer
MSDP: 224.150.44.254: Received 116-byte message from peer
MSDP: 224.150.44.254: SA TLV, len: 116, ec: 9, RP: 172.31.3.111
MSDP: 224.150.44.254: Peer RPF check passed for 172.31.3.111, used EMBGP peer
MSDP: 224.150.44.250: Forward 116-byte SA to peer
MSDP: 224.150.44.254: Received 32-byte message from peer
MSDP: 224.150.44.254: SA TLV, len: 32, ec: 2, RP: 172.31.3.78
MSDP: 224.150.44.254: Peer RPF check passed for 172.31.3.78, used EMBGP peer
MSDP: 224.150.44.250: Forward 32-byte SA to peer

```

Step 3 **debug ip msdp resets**

Use this command to debug MSDP peer reset reasons.

Example:

```
Device# debug ip msdp resets
```

Step 4 **show ip msdp count** [*as-number*]

Use this command to display the number of sources and groups originated in MSDP SA messages and the number of SA messages from an MSDP peer in the SA cache. The **ip msdp cache-sa-state** command must be configured for this command to produce any output.

The following is sample output from the **show ip msdp count** command:

Example:

```

Device# show ip msdp count
SA State per Peer Counters, <Peer>: <# SA learned>
 192.168.4.4: 8
SA State per ASN Counters, <asn>: <# sources>/<# groups>
 Total entries: 8
  ?: 8/8

```

Step 5 **show ip msdp peer** [*peer-address* | *peer-name*]

Use this command to display detailed information about MSDP peers.

Use the optional *peer-address* or *peer-name* argument to display information about a particular peer.

The following is sample output from the **show ip msdp peer** command:

Example:

```

Device# show ip msdp peer 192.168.4.4
MSDP Peer 192.168.4.4 (?), AS 64512 (configured AS)
Connection status:
 State: Up, Resets: 0, Connection source: Loopback0 (2.2.2.2)
 Uptime(Downtime): 00:07:55, Messages sent/received: 8/18
 Output messages discarded: 0
 Connection and counters cleared 00:08:55 ago
SA Filtering:
 Input (S,G) filter: none, route-map: none
 Input RP filter: none, route-map: none
 Output (S,G) filter: none, route-map: none
 Output RP filter: none, route-map: none
SA-Requests:
 Input filter: none
 Peer ttl threshold: 0
 SAs learned from this peer: 8

```

```
Input queue size: 0, Output queue size: 0
MD5 signature protection on MSDP TCP connection: not enabled
```

Step 6 `show ip msdp sa-cache` [*group-address* | *source-address* | *group-name* | *source-name*] [*as-number*]
Use this command to display the (S, G) state learned from MSDP peers.

The following is sample output from the `show ip msdp sa-cache` command:

Example:

```
Device# show ip msdp sa-cache
MSDP Source-Active Cache - 8 entries
(10.44.44.5, 239.232.1.0), RP 192.168.4.4, BGP/AS 64512, 00:01:20/00:05:32, Peer 192.168.4.4
(10.44.44.5, 239.232.1.1), RP 192.168.4.4, BGP/AS 64512, 00:01:20/00:05:32, Peer 192.168.4.4
(10.44.44.5, 239.232.1.2), RP 192.168.4.4, BGP/AS 64512, 00:01:19/00:05:32, Peer 192.168.4.4
(10.44.44.5, 239.232.1.3), RP 192.168.4.4, BGP/AS 64512, 00:01:19/00:05:32, Peer 192.168.4.4
(10.44.44.5, 239.232.1.4), RP 192.168.4.4, BGP/AS 64512, 00:01:19/00:05:32, Peer 192.168.4.4
(10.44.44.5, 239.232.1.5), RP 192.168.4.4, BGP/AS 64512, 00:01:19/00:05:32, Peer 192.168.4.4
(10.44.44.5, 239.232.1.6), RP 192.168.4.4, BGP/AS 64512, 00:01:19/00:05:32, Peer 192.168.4.4
(10.44.44.5, 239.232.1.7), RP 192.168.4.4, BGP/AS 64512, 00:01:19/00:05:32, Peer 192.168.4.4
```

Step 7 `show ip msdp summary`
Use this command to display MSDP peer status.

The following is sample output from the `show ip msdp summary` command:

Example:

```
Device# show ip msdp summary
MSDP Peer Status Summary
Peer Address    AS    State    Uptime/  Reset SA    Peer Name
                AS    State    Downtime Count Count
192.168.4.4    4     Up       00:08:05 0      8      ?
```

Clearing MSDP Connections Statistics and SA Cache Entries

Perform this optional task to clear MSDP connections, statistics, and SA cache entries.

SUMMARY STEPS

1. `enable`
2. `clear ip msdp peer` [*peer-address* | *peer-name*]
3. `clear ip msdp statistics` [*peer-address* | *peer-name*]
4. `clear ip msdp sa-cache` [*group-address*]

DETAILED STEPS

	Command or Action	Purpose
Step 1	<code>enable</code>	Enables privileged EXEC mode.

	Command or Action	Purpose
	<p>Example:</p> <pre>Device> enable</pre>	<ul style="list-style-type: none"> • Enter your password if prompted.
Step 2	<p>clear ip msdp peer [<i>peer-address</i> <i>peer-name</i>]</p> <p>Example:</p> <pre>Device# clear ip msdp peer</pre>	Clears the TCP connection to the specified MSDP peer and resets all MSDP message counters.
Step 3	<p>clear ip msdp statistics [<i>peer-address</i> <i>peer-name</i>]</p> <p>Example:</p> <pre>Device# clear ip msdp statistics</pre>	Clears the statistics counters for the specified MSDP peer and resets all MSDP message counters.
Step 4	<p>clear ip msdp sa-cache [<i>group-address</i>]</p> <p>Example:</p> <pre>Device# clear ip msdp sa-cache</pre>	<p>Clears SA cache entries.</p> <ul style="list-style-type: none"> • If the clear ip msdp sa-cache is specified with the optional <i>group-address</i> argument or <i>source-address</i> argument, all SA cache entries are cleared. • Use the optional <i>group-address</i> argument to clear all SA cache entries associated with a specific group.

Configuration Examples for Configuring MSDP

Configuring a Default MSDP Peer: Example

This example shows a partial configuration of Router A and Router C in . Each of these ISPs have more than one customer (like the customer in) who use default peering (no BGP or MBGP). In that case, they might have similar configurations. That is, they accept SAs only from a default peer if the SA is permitted by the corresponding prefix list.

Router A

```
Router(config)# ip msdp default-peer 10.1.1.1
Router(config)# ip msdp default-peer 10.1.1.1 prefix-list site-a
Router(config)# ip prefix-list site-b permit 10.0.0.0/1
```

Router C

```
Router(config)# ip msdp default-peer 10.1.1.1 prefix-list site-a
Router(config)# ip prefix-list site-b permit 10.0.0.0/1
```

Caching Source-Active State: Example

This example shows how to enable the cache state for all sources in 171.69.0.0/16 sending to groups 224.2.0.0/16:

```
Switch(config)# ip msdp cache-sa-state 100
Switch(config)# access-list 100 permit ip 171.69.0.0 0.0.255.255 224.2.0.0 0.0.255.255
```

Requesting Source Information from an MSDP Peer: Example

This example shows how to configure the switch to send SA request messages to the MSDP peer at 171.69.1.1:

```
Switch(config)# ip msdp sa-request 171.69.1.1
```

Controlling Source Information that Your Switch Originates: Example

This example shows how to configure the switch to filter SA request messages from the MSDP peer at 171.69.2.2. SA request messages from sources on network 192.4.22.0 pass access list 1 and are accepted; all others are ignored.

```
Switch(config)# ip msdp filter sa-request 171.69.2.2 list 1
Switch(config)# access-list 1 permit 192.4.22.0 0.0.0.255
```

Controlling Source Information that Your Switch Forwards: Example

This example shows how to allow only (S,G) pairs that pass access list 100 to be forwarded in an SA message to the peer named *switch.cisco.com*:

```
Switch(config)# ip msdp peer switch.cisco.com connect-source gigabitethernet1/0/1
Switch(config)# ip msdp sa-filter out switch.cisco.com list 100
Switch(config)# access-list 100 permit ip 171.69.0.0 0.0.255.255 224.2.0.0 0.0.255.255
```

Controlling Source Information that Your Switch Receives: Example

This example shows how to filter all SA messages from the peer named *switch.cisco.com*:

```
Switch(config)# ip msdp peer switch.cisco.com connect-source gigabitethernet1/0/1
Switch(config)# ip msdp sa-filter in switch.cisco.com
```

Example: Configuring MSDP Mesh Groups

The following example shows how to configure three devices to be fully meshed members of an MSDP mesh group:

Device A Configuration

```
ip msdp peer 10.2.2.2
ip msdp peer 10.3.3.3
ip msdp mesh-group test-mesh-group 10.2.2.2
ip msdp mesh-group test-mesh-group 10.3.3.3
```

Device B Configuration

```
ip msdp peer 10.1.1.1
ip msdp peer 10.3.3.3
ip msdp mesh-group test-mesh-group 10.1.1.1
ip msdp mesh-group test-mesh-group 10.3.3.3
```

Device C Configuration

```
ip msdp peer 10.1.1.1
ip msdp peer 10.2.2.2
ip msdp mesh-group test-mesh-group 10.1.1.1
ip msdp mesh-group test-mesh-group 10.2.2.2
```

Requesting Source Information from an MSDP Peer: Example

This example shows how to configure the switch to send SA request messages to the MSDP peer at 171.69.1.1:

```
Switch(config)# ip msdp sa-request 171.69.1.1
```

Additional References

Related Documents

Related Topic	Document Title
For complete syntax and usage information for the commands used in this chapter.	<i>Command Reference, Cisco Release 15.2(2)E (Industrial Ethernet 3000 Switch)</i>
Cisco IOS commands	Cisco IOS Master Commands List, All Releases
IP multicast commands	Cisco IOS IP Multicast Command Reference

Error Message Decoder

Description	Link
To help you research and resolve system error messages in this release, use the Error Message Decoder tool.	https://www.cisco.com/cgi-bin/Support/Errordecoder/index.cgi

Standards and RFC

Standard/RFC	Title
RFC 3618	Multicast Source Discovery Protocol

MIBs

MIB	MIBs Link
All supported MIBs for this release.	To locate and download MIBs for selected platforms, Cisco IOS releases, and feature sets, use Cisco MIB Locator found at the following URL: http://www.cisco.com/go/mibs

Technical Assistance

Description	Link
<p>The Cisco Support website provides extensive online resources, including documentation and tools for troubleshooting and resolving technical issues with Cisco products and technologies.</p> <p>To receive security and technical information about your products, you can subscribe to various services, such as the Product Alert Tool (accessed from Field Notices), the Cisco Technical Services Newsletter, and Really Simple Syndication (RSS) Feeds.</p> <p>Access to most tools on the Cisco Support website requires a Cisco.com user ID and password.</p>	http://www.cisco.com/support



INDEX

- A**
- address aliasing [160](#)
 - addresses [5, 7](#)
 - globally scoped [5](#)
 - GLOP [5](#)
 - IP multicast class D [5](#)
 - layer 2 multicast [7](#)
 - limited scope [5](#)
 - multicast [5](#)
 - reserved link-local [5](#)
 - SSM [5](#)
 - Auto-RP [62](#)
- B**
- BIP multicast routing [116](#)
 - bootstrap router [50](#)
 - BSRs [78](#)
 - candidate [78](#)
- C**
- Caching Source-Active State [240](#)
 - Example command [240](#)
 - CGMP [36](#)
 - enabling server support [36](#)
 - server support only [36](#)
 - Class D addresses [5](#)
 - clearing [126](#)
 - caches [126](#)
 - databases [126](#)
 - tables [126](#)
 - compatible mode [165](#)
 - configurable leave timer, IGMP [163](#)
 - Configuration Examples for Configuring MSDP command [239](#)
 - Configuring a Default MDSP Peer [239](#)
 - Example command [239](#)
 - configuring multicast VRFs [123](#)
 - Controlling Source Information that Your Switch Forwards [240](#)
 - Example command [240](#)
 - Controlling Source Information that Your Switch Originates [240](#)
 - Example command [240](#)
 - Controlling Source Information that Your Switch Receives [240](#)
 - Example command [240](#)
- D**
- default configuration [18, 57, 164, 167, 168](#)
 - IGMP [18](#)
 - IGMP filtering [168](#)
 - IGMP snooping [164](#)
 - IGMP throttling [168](#)
 - MVR [167](#)
 - PIM [57](#)
 - dense mode [45](#)
 - DVMRP (Distance Vector Multicast Routing Protocol) [2](#)
 - See IP multicast routing, DVMRP [2](#)
 - dynamic mode [165](#)
- F**
- false RPs [70](#)
- G**
- global leave, IGMP [181](#)
 - globally scoped addresses [5](#)
 - GLOP addresses [5](#)
- H**
- host signalling [14](#)

- I
 - IGMP [12, 13, 14, 16, 17, 18, 24, 26, 28, 30, 161, 163, 164, 165, 178, 179, 181, 182, 186](#)
 - configurable leave timer [163, 178](#)
 - described [163](#)
 - multicast addresses [13](#)
 - configurable leave timer [163, 178](#)
 - enabling [178](#)
 - configuring the switch [18, 30](#)
 - as a member of a group [18](#)
 - statically connected member [30](#)
 - default configuration [18](#)
 - flooded multicast traffic [179, 181, 182](#)
 - controlling the length of time [179](#)
 - disabling on an interface [182](#)
 - global leave [181](#)
 - recovering from flood mode [181](#)
 - host-query interval, modifying [24](#)
 - join messages [161](#)
 - join process [16](#)
 - leave process [17](#)
 - leaving multicast group [163](#)
 - maximum query response time value [28](#)
 - multicast reachability [18](#)
 - pruning groups [28](#)
 - queries [161](#)
 - query timeout [26](#)
 - query timeout [26](#)
 - report suppression [164, 186](#)
 - described [164](#)
 - disabling [186](#)
 - role [12](#)
 - supported versions [13, 161](#)
 - Version 1 [13](#)
 - Version 2 [13](#)
 - Version 3 [14](#)
 - version differences [14](#)
 - IGMP filtering [167, 168](#)
 - default configuration [168](#)
 - described [167](#)
 - IGMP groups [196, 198](#)
 - configuring filtering [198](#)
 - setting the maximum number [196](#)
 - IGMP helper [48](#)
 - IGMP Immediate Leave [158, 176](#)
 - enabling [176](#)
 - IGMP profile [192, 195](#)
 - applying [195](#)
 - configuration mode [192](#)
 - IGMP report suppression [158](#)
 - IGMP snooping [13, 157, 160, 161, 163, 164, 169, 170, 184](#)
 - and address aliasing [160](#)
 - default configuration [164](#)
 - IGMP snooping (*continued*)
 - definition [160](#)
 - enabling and disabling [169](#)
 - global configuration [169](#)
 - Immediate Leave [163](#)
 - querier [157, 184](#)
 - configuration guidelines [157](#)
 - configuring [184](#)
 - supported versions [13, 161](#)
 - VLAN configuration [170](#)
 - IGMP throttling [167, 168, 198, 202](#)
 - configuring [198](#)
 - default configuration [168](#)
 - described [167](#)
 - displaying action [202](#)
 - IGMP Throttling Action [158](#)
 - configuration guidelines [158](#)
 - IGMP version [22](#)
 - IGMPv3 [14](#)
 - Immediate Leave, IGMP [163](#)
 - described [163](#)
 - IP [2](#)
 - PIM [2](#)
 - See IP multicast routing, PIM [2](#)
 - IP multicast [1, 5, 7](#)
 - delivery modes any source multicast [7](#)
 - group addressing [5](#)
 - role in information delivery [1](#)
 - IP multicast boundary [75, 121](#)
 - IP multicast routing [2, 42, 73, 93, 116, 117, 118, 120, 127](#)
 - DVMRP [2](#)
 - definition [2](#)
 - enabling [120](#)
 - PIM mode [120](#)
 - IGMP [2](#)
 - purpose [2](#)
 - MBONE [2, 117, 118](#)
 - described [117](#)
 - SAP packets for conference session announcement [118](#)
 - PIMv1 and PIMv2 interoperability [42](#)
 - RP [73, 93](#)
 - configuring PIMv2 BSR [73](#)
 - monitoring mapping information [93](#)
 - stacking [116](#)
 - active switch functions [116](#)
 - stack member functions [116](#)
 - statistics, displaying system and network [127](#)
- J
 - join messages, IGMP [161](#)

- L**
- limited scope addresses [5](#)
- M**
- MBONE [117](#)
 - MBONE (multicast backbone) [2](#)
 - monitoring [31, 93, 126, 128, 149, 201](#)
 - multicast router interfaces [201](#)
 - BSR information [93](#)
 - IGMP [31](#)
 - IP [126](#)
 - multicast routing [126](#)
 - IP multicast routing [128](#)
 - RP mapping information [93](#)
 - SSM mapping [149](#)
 - multicast forwarding [51](#)
 - multicast group transmission scheme [2](#)
 - multicast groups [161, 163, 174](#)
 - joining [161](#)
 - leaving [163](#)
 - static joins [174](#)
 - multicast multimedia sessions, advertising [125](#)
 - Multicast Pings [91, 92](#)
 - configuring routers [91](#)
 - pinging routers [92](#)
 - multicast router interfaces, monitoring [201](#)
 - multicast router ports, adding [173](#)
 - multicast television application [166](#)
 - MVR [165, 167](#)
 - default configuration [167](#)
 - described [165](#)
 - MVR interfaces [190](#)
 - MVR parameters [187](#)
- P**
- PIM [42, 47, 57, 81, 83, 93, 94, 120](#)
 - default configuration [57](#)
 - enabling a mode [120](#)
 - monitoring [93](#)
 - router-query message interval, modifying [83](#)
 - shortest path tree, delaying the use of [81](#)
 - versions [42, 47, 94](#)
 - interoperability [42](#)
 - troubleshooting interoperability problems [94](#)
 - v2 improvements [47](#)
 - PIM dense mode [45](#)
 - PIM domain border [51, 73](#)
 - PIM shared tree [54](#)
 - PIM source tree [54](#)
 - PIM stub routing [43, 47, 58](#)
 - PIM-SSM [133](#)
 - prerequisites [35, 131, 157](#)
 - CGMP [35](#)
 - IGMP snooping [157](#)
 - SSM [131](#)
 - Protocol Independent Multicast [44](#)
- Q**
- queries, IGMP [161](#)
- R**
- rendezvous point [60](#)
 - report suppression, IGMP [164, 186](#)
 - described [164](#)
 - disabling [186](#)
 - Requesting Source Information from an MSDP Peer [240, 241](#)
 - Example command [240, 241](#)
 - reserved link-local addresses [5](#)
 - restrictions [12, 35, 132, 158, 159](#)
 - CGMP [35](#)
 - IGMP [12](#)
 - IGMP snooping [158](#)
 - SSM [132](#)
 - RFC [160](#)
 - 1112, IP multicast and IGMP [160](#)
 - RP [60, 65](#)
 - sparse-mode cloud [65](#)
 - RP announcement messages [71](#)
 - RPF [55](#)
 - RPF check fails (figure) [56](#)
 - RPF check succeeds (figure) [56](#)
 - RPs [79](#)
 - candidate [79](#)
- S**
- SAP listener [125](#)
 - sdr [117](#)
 - shared tree [52, 53](#)
 - advantage [53](#)
 - source specific multicast [7](#)
 - source tree [53](#)
 - advantage [53](#)
 - sparse mode [45, 68](#)
 - with static RP [68](#)
 - sparse-dense mode [46](#)

- SSM [5](#), [133](#), [135](#), [139](#)
 - addresses [5](#)
 - configuring [139](#)
 - IGMPv3 host signalling [135](#)
 - overview [133](#)
 - SSM (Source Specific Multicast) [133](#), [134](#)
 - differences from ISM [133](#)
 - operations [134](#)
 - SSM mapping [136](#), [137](#), [141](#), [145](#), [149](#)
 - DNS-based SSM mapping [137](#)
 - monitoring [149](#)
 - overview [136](#)
 - static SSM mapping [137](#)
 - static traffic forwarding [145](#)
 - SSM Mapping [143](#), [147](#)
 - configuring DNS-based SSM mapping [143](#)
 - verifying configuration and operation [147](#)
 - SSM, ISM and IGMPv3 [135](#)
 - stack changes, effects on [117](#)
 - multicast routing [117](#)
 - stacks, switch [116](#)
 - multicast routing, active switch and member roles [116](#)
 - statistics [127](#)
 - IP multicast routing [127](#)
- T**
- troubleshooting [94](#)
 - PIMv1 and PIMv2 interoperability problems [94](#)
- V**
- Verifying multicast operations [86](#), [87](#), [88](#)
 - last hop router [88](#)
 - on routers along the SPT [86](#), [87](#)
 - VRFs, configuring multicast [123](#)