

## Advanced Services' Implementing Cisco Data Over Cable Service Interface Specification (DOCSIS) 3.0 v2



The Cisco Data Over Cable Service Interface Specification (DOCSIS) 3.0 course covers primary cable modem termination system (CMTS) standards and concepts, provides hands-on expertise, and establishes important foundation knowledge for bidirectional channel bonding and other advanced service cable technologies. Architectures emphasized through lecture and lab exercises include both modular CMTS (M-CMTS) and integrated CMTS (I-CMTS). While this course focuses on implementing DOCSIS services on the Cisco® uBR10012, the learning experiences from this course also apply to other CMTS's that support DOCSIS 3.0 technology.

### Duration

Four days.

### Target Audience

This course is for technical professionals who design, implement, and operate Cisco CMTS equipment and who deploy DOCSIS 3.0 features in cable networks.

The following are considered the primary audience for this course:

- Cable operator engineers
- Cable operator network operations center personnel
- System integrators
- System engineers

### Course Objectives

Upon completion of this course, you should be able to:

- Identify the pre-DOCSIS 3.0 Cisco technology and deployment foundation underpinning current DOCSIS 3.0 downstream channel bonding.
- Describe the component parts of the DOCSIS 3.0 specification set and explain primary aspects in block-diagram form.

- Explain modular and integrated CMTS concepts and how they relate to DOCSIS 3.0.
- Relate downstream channel bonding terms and acronyms to Cisco uBR10012 downstream channel bonding hardware and software releases.
- Identify Cisco uBR10012 hardware combinations required for downstream channel bonding.
- Configure and verify Cisco uBR10012 for downstream channel bonding operations in an I-CMTS configuration.
- Configure and verify Cisco uBR10012 for downstream channel bonding operations in an M-CMTS configuration.
- Configure necessary third-party DOCSIS 3.0 components such as the Symmetricon DTI server and gain knowledge necessary to recognize the role of any third-party components in a customer's M-CMTS design.
- Use new Cisco uBR10012 features and featurettes for best system performance in mixed DOCSIS 1.x/2.0 and DOCSIS 3.0 downstream channel-bonded environments.
- Use lessons learned from earlier worldwide downstream channel bonding deployments.
- Describe next steps in channel bonding that build upon Cisco uBR10012 downstream channel bonding and enable still more advanced services.

### Course Prerequisites

Following are the prerequisites for this course.

- Students should have knowledge of Cisco CMTS equipment and should be able to establish, without assistance, a configuration for Cisco uBR10012.
- Students must have attended or have equivalent knowledge and experience of the Cisco Introduction to Cisco Cable Routing (ICCR) course and the Advance Cisco Cable Routing (ACCR) course.

To locate Cisco courses that cover the listed prerequisites, go to the Cisco Training and Events webpage at [www.cisco.com/web/learning/index.html](http://www.cisco.com/web/learning/index.html).

### Course Outline

The course outline is as follows:

- Course Introduction
- DOCSIS 3.0 Specification
- Understanding DOCSIS 3.0 Theory of Operation and CMTS Architecture
- CableLabs DOCSIS 3.0 Qualification and Cisco CMTS Naming Conventions
- DOCSIS 3.0 Terms
- Cisco uBR10012 Hardware and External Hardware for M-CMTS Architecture
- Cisco uBR10012 Hardware for I-CMTS Architecture
- Downstream Channel Bonding Commands: M-CMTS and I-CMTS
- Features and Featurettes for Advanced Performance and Service Differentiation: Load Balancing, Cable Modem Steering, High-Availability N+1, Dynamic Bandwidth Sharing
- Troubleshooting
- Channel Bonding Tips

## Lab Outline

The lab outline is as follows:

- Preplan Cisco uBR10012 and DOCSIS 3.0 deployment scenarios: M-CMTS
- Configure the Cisco uBR10012 CMTS, the Cisco RF gateway, and the DOCSIS timing server
- Configure the Cisco wideband SPA (controller modular cable)
- Configure two Cisco wideband RF channels
- Configure two primary downstream channels/channel grouping domains: M-CMTS
- Configure a fiber node
- Configure DOCSIS timing and control card
- Configure the edge QAM (RF gateway)
- Configure load balancing group
- Configure an interface for upstream load balancing
- Configure two primary downstream channels/channel grouping domains: I-CMTS
- Add downstream channels to the load balancing group: M-CMTS
- Add downstream channels to the load balancing group: I-CMTS
- Configure Cisco uBR10012 high availability and N+1 redundancy
- Configure DOCSIS 3 load balancing, including cable modem steering
- Configure dynamic bandwidth sharing (DBS) on the Cisco uBR10012
- Troubleshooting break/fix lab

## Lab Topology

Figure 1 shows the lab components that are used in this course.

**Figure 1.** Cisco DOCSIS 3.0 Lab Architecture

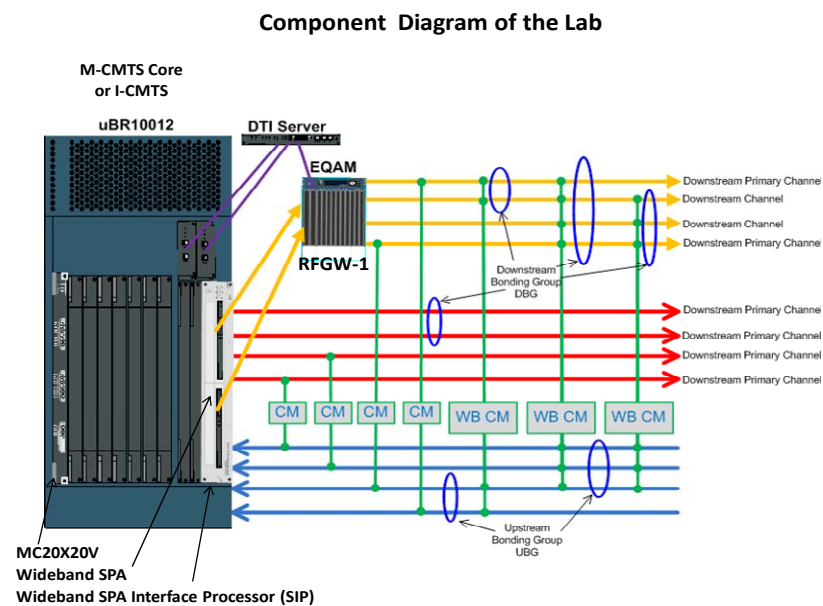

## Registration Information

For more information about schedules and registration for this course, contact [aeskt\\_registration@cisco.com](mailto:aeskt_registration@cisco.com).

## For More Information

For more information about Advanced Services Education course offerings, including custom training options, as well as Advanced Services Curriculum Planning Services and the Advanced Services Technical Knowledge Library (TKL), refer to the Advanced Services Education website at [www.cisco.com/go/ase](http://www.cisco.com/go/ase).



**Americas Headquarters**  
Cisco Systems, Inc.  
San Jose, CA

**Asia Pacific Headquarters**  
Cisco Systems (USA) Pte. Ltd.  
Singapore

**Europe Headquarters**  
Cisco Systems International BV  
Amsterdam, The Netherlands

Cisco has more than 200 offices worldwide. Addresses, phone numbers, and fax numbers are listed on the Cisco Website at [www.cisco.com/go/offices](http://www.cisco.com/go/offices).

CCDE, CCENT, CCSI, Cisco Eos, Cisco HealthPresence, the Cisco logo, Cisco Lumin, Cisco Nexus, Cisco Nurse Connect, Cisco Stackpower, Cisco StadiumVision, Cisco TelePresence, Cisco WebEx, DCE, and Welcome to the Human Network are trademarks; Changing the Way We Work, Live, Play, and Learn and Cisco Store are service marks; and Access Registrar, Aironet, AsyncOS, Bringing the Meeting To You, Catalyst, CCDA, CCDP, CCIE, CCIP, CCNA, CCNP, CCSP, CCVP, Cisco, the Cisco Certified Internetwork Expert logo, Cisco IOS, Cisco Press, Cisco Systems, Cisco Systems Capital, the Cisco Systems logo, Cisco Unity, Collaboration Without Limitation, EtherFast, EtherSwitch, Event Center, Fast Step, Follow Me Browsing, FormShare, GigaDrive, HomeLink, Internet Quotient, IOS, iPhone, iQuick Study, IronPort, the IronPort logo, LightStream, Linksys, MediaTone, MeetingPlace, MeetingPlace Chime Sound, MGX, Networkers, Networking Academy, Network Registrar, PCNow, PIX, PowerPanels, ProConnect, ScriptShare, SenderBase, SMARTnet, Spectrum Expert, StackWise, The Fastest Way to Increase Your Internet Quotient, TransPath, WebEx, and the WebEx logo are registered trademarks of Cisco Systems, Inc. and/or its affiliates in the United States and certain other countries.

All other trademarks mentioned in this document or website are the property of their respective owners. The use of the word partner does not imply a partnership relationship between Cisco and any other company. (0903R)