

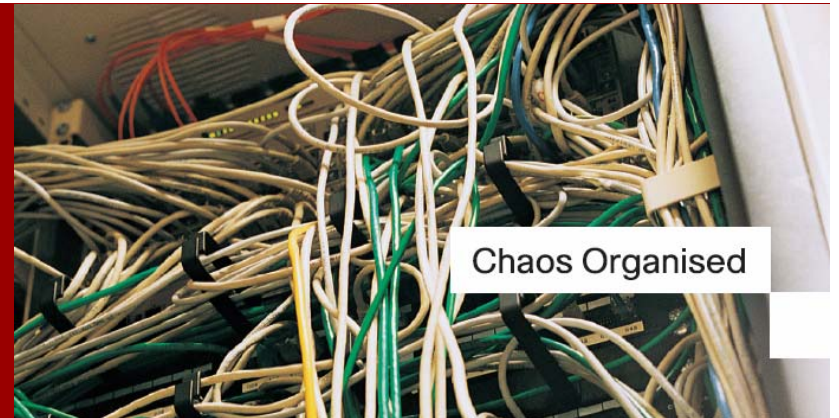

## Cisco Data Center Day 2006

# Building Tomorrow's Intelligent SAN Today



Chaos Organised

**Rajinder Singh**  
Product Manager – Storage Networking  
Cisco Systems APAC

# Agenda

- **Storage Challenges and Trends**
- Cisco Storage Consolidation Solutions
- Cisco Storage Virtualization Solutions
- Summary

# Perspectives on Storage

CTO/CIO

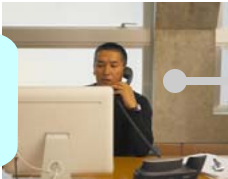

“Storage TCO Continues to Grow and Will Soon Eat up More Than 50% of Our IT Budget”

Apps



“Information Management Is a Critical Concern”

“Our Applications Rely on the Availability and Integrity of the Data It Runs on”

Server



“I Used to Own the Storage. Now I Rely on the Storage Network to Provide Connectivity to Shared Storage Resources”

SecOps

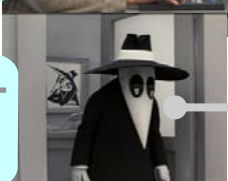

“Now That Storage Is Becoming a Shared Resource, We Need to Ensure That Access and Confidentiality Are Addressed”

Storage



“Storage Is Growing Much Faster Than I Can Grow My Budget or My Team. I Need to Find Ways to Deploy, Manage and

Network



“The Storage Network Is Beginning to Take Advantage of Many of The Technologies That We Are Accustomed to in The Traditional Network Space ”

# Top of Mind Storage Challenges

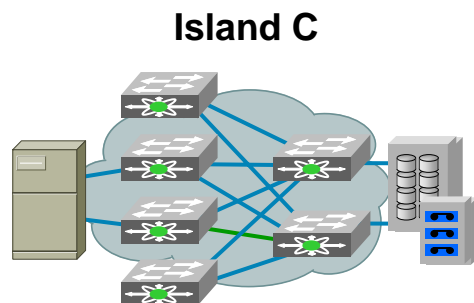
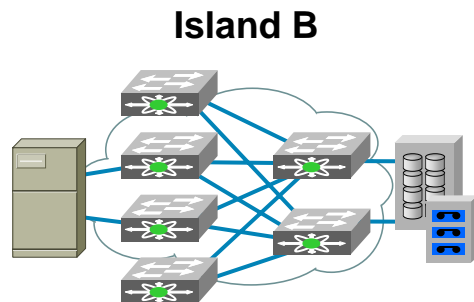
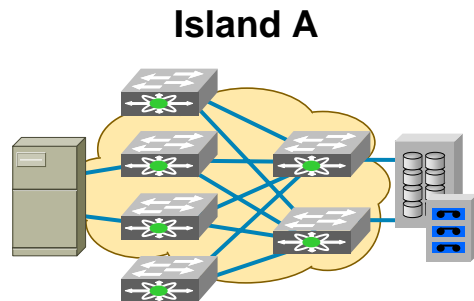

## Rising TCO

- Rapid storage growth
- Overhead of managing discrete storage islands
- Under-utilization of disparate storage silos

## Inflexibility

- Slow inefficient storage provisioning
- Difficulty in mixing heterogeneous storage
- Challenges of sharing resources such as Tape

## Business Continuance

- Minimizing cost and improving consistency
- Compliance with Regulations
- Extend distance without impacting applications

# Evolution of the Data Center Infrastructure

## Multilayer Storage Utility Evolution

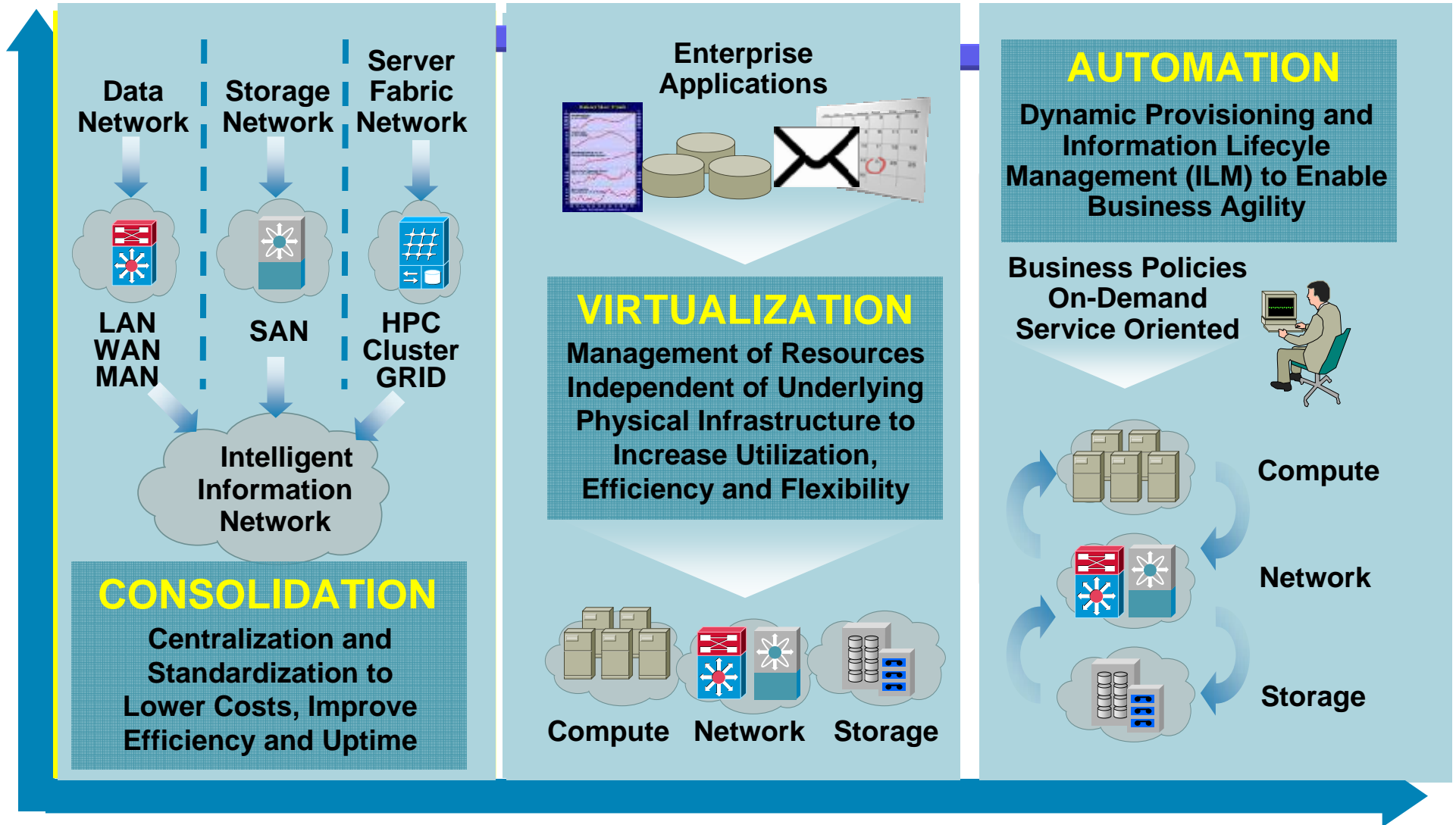

# Agenda

- Storage Challenges and Trends
- **Cisco Storage Consolidation Solutions**
- Cisco Storage Virtualization Solutions
- Summary

# Cisco SAN and Storage Consolidation Solutions

- SAN and Storage Consolidation Improve:

**Storage Utilization** —provides a means of efficiently sharing storage resources across applications

**Management Efficiency** —provides a single infrastructure to manage and maintain

**Resource Sharing** —allows shared use of centralized resources such as Tape

**Heterogeneous Storage** —enables deployment of heterogeneous storage, operating systems and protocols onto single physical SAN



# SAN Consolidation on Cisco MDS 9000 Family

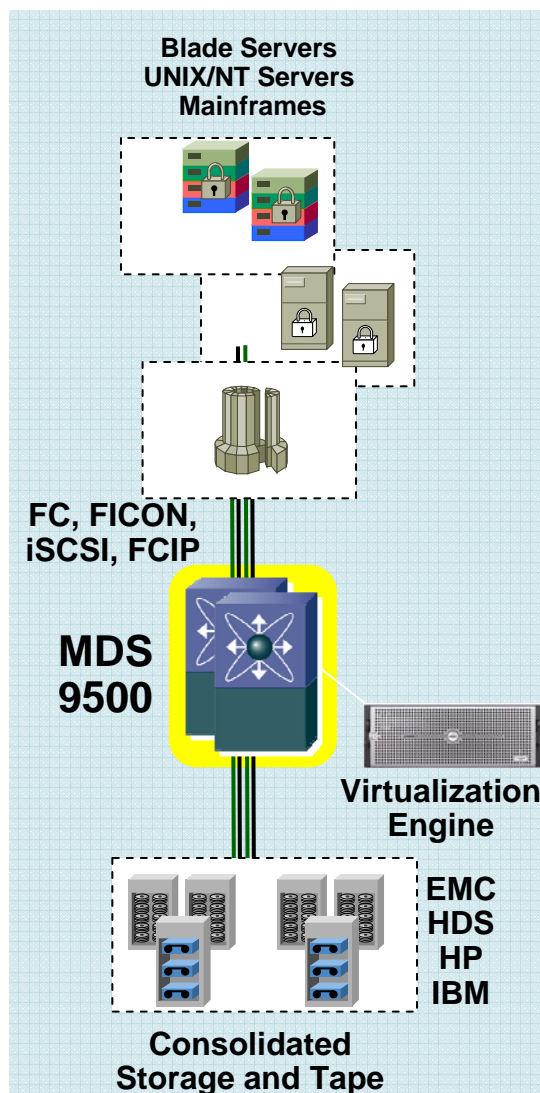

## Scalability and Availability

- Non-disruptive software upgrades, stateful failover
- VSANs and Inter-VSAN Routing (IVR)
- 2.2 Tbps switching bandwidth
- 528 FC ports in 14RU (Cisco MDS 9513)

## Virtualization Platform

- Hosts 3<sup>rd</sup> party virtualization engines via standard API
- Enhances reliability, performance and transparency

## Troubleshooting

- Embedded FC Analyzer
- FC Ping and FC Traceroute
- Remote SPAN (RSPAN)
- Hot-spot analysis

## Heterogeneous Fabrics

- Heterogeneous environments—NT, UNIX, MF, multi-vendor
- Multi-protocol FC, FICON, iSCSI
- Interoperability with legacy switches

# Consolidation Using Cisco's Virtual SAN (VSAN) Technology

- Virtual fabrics support the need to consolidate numerous SAN islands
- Fabrics can be migrated from physical to virtual implementations
- New fabrics are provisioned through switch commands, not physical adds, moves, changes
- Fabrics provide basis for shared network-based storage services

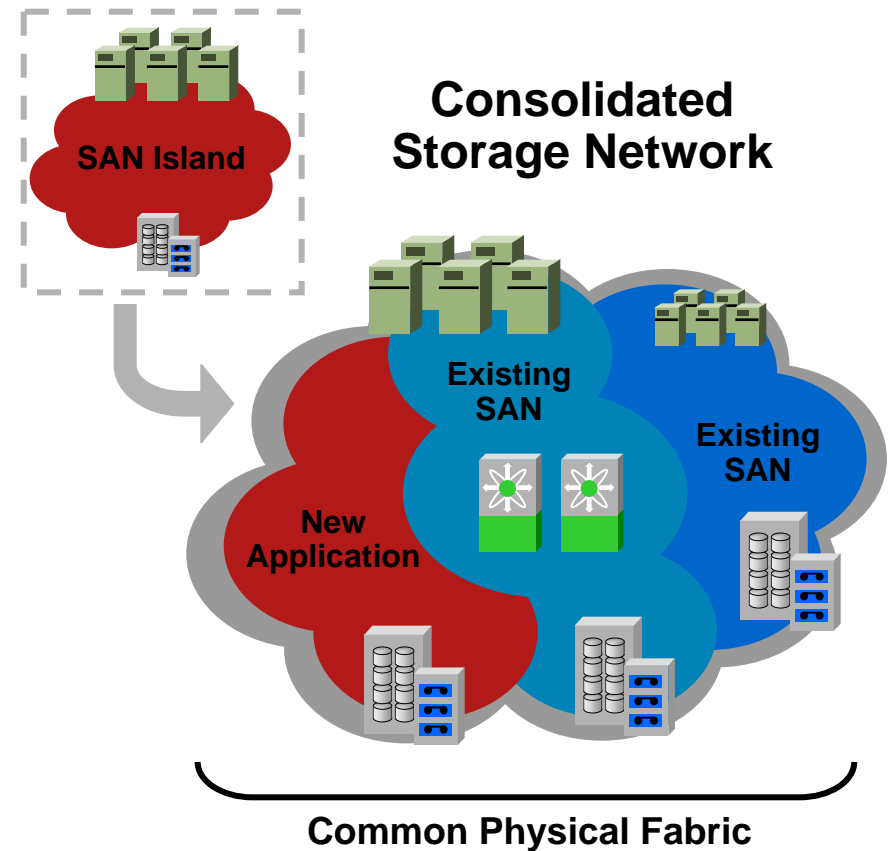

# Virtual SANs Raise Fabric Availability

- **Virtual SANs sectionalize fabric to increase availability**
- **High availability—all fabric services are replicated and maintained per VSAN (eg. name service, etc.)**
- **Fabric events are isolated per VSAN**
  - Misbehaving HBA or controller
  - Fabric rebuild event
  - Zone set change
- **Fabric recovery from a disruptive event is 'per VSAN' resulting in faster reconvergence—smaller scope**

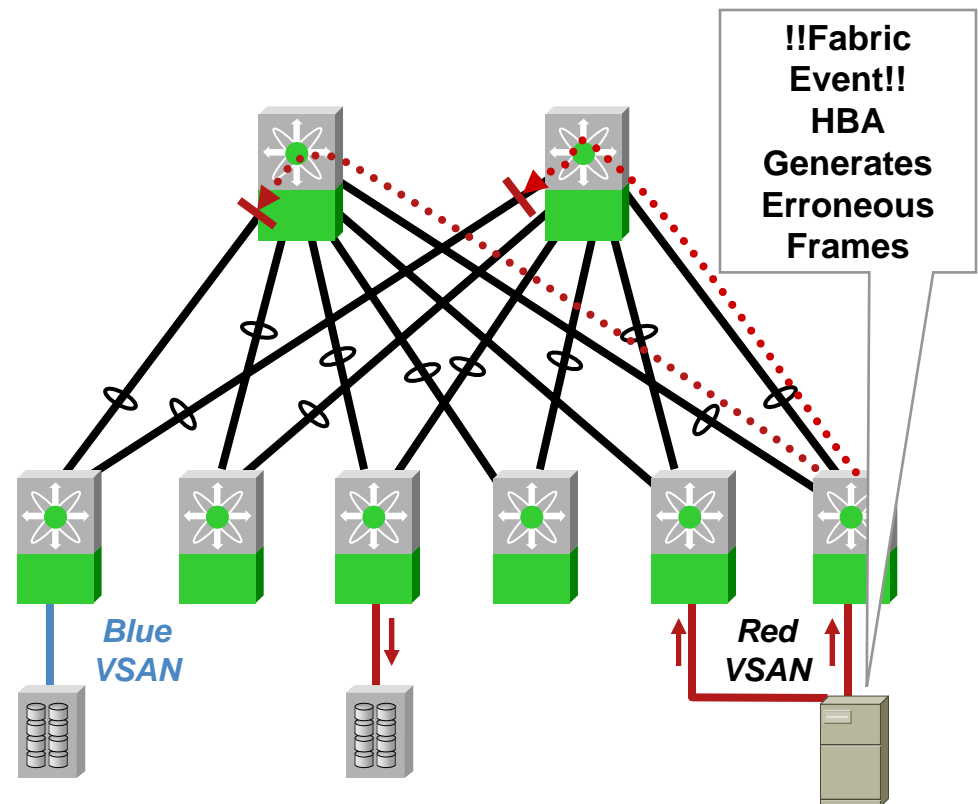

**Faults Are Constrained to the Extents of the VSAN and Only Affect Devices within the VSAN**

# VSAN-Based Roles—Just Like SAN Islands

- Enables deployment of VSANs that fit existing operational models
- Network admin configures all platform-specific capabilities and VSAN allocations
- VSAN-admin(s) configure and manage their own VSANs
- The existing “role” definition is enhanced to include VSAN(s)



**Network Administrator**  
VSAN Provisioning

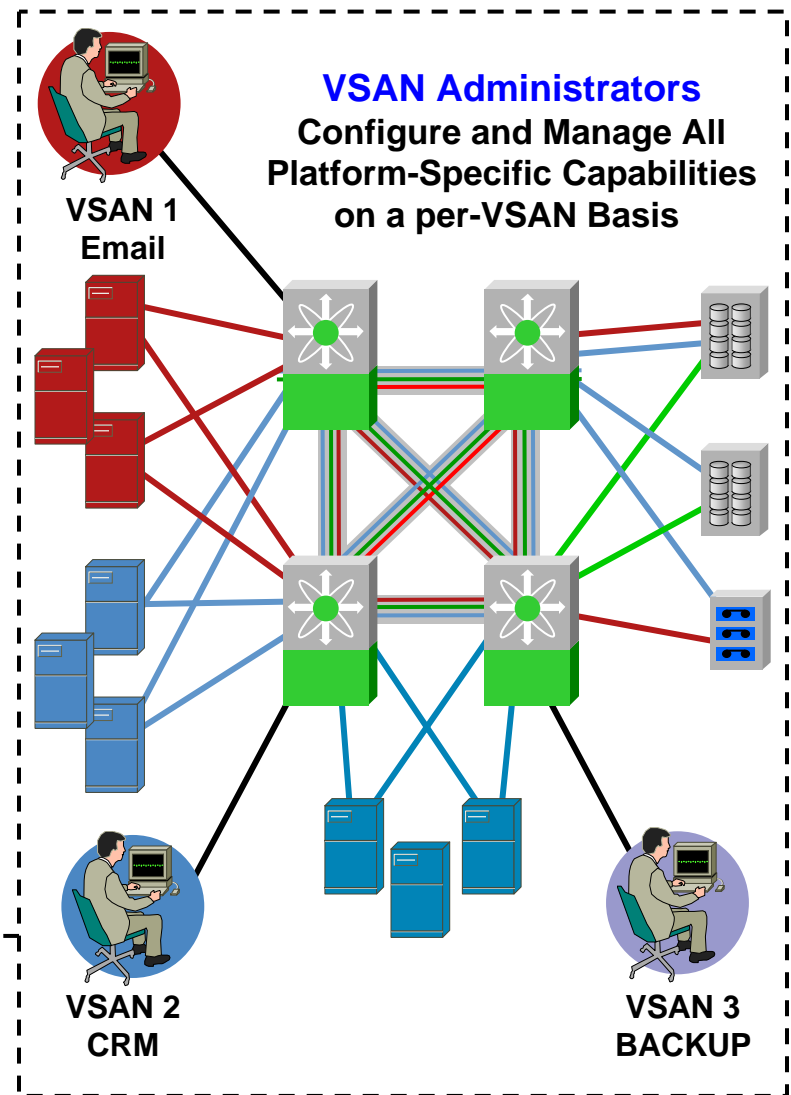

# Inter-VSAN Routing (IVR): Sharing Resources Across VSANs

Industry  
First

- Allows sharing of centralized storage services such as tape libraries and disks across VSANs—without merging separate fabrics (VSANs)
- Provides high fabric resiliency and VSAN-based manageability

Works for all Cisco MDS 9000 Switches with a software upgrade to SAN-OS 1.3(1)

Distributed, scalable, and highly resilient architecture

Transparent to third-party switches

- Enables blade-per-VSAN architecture for blade servers

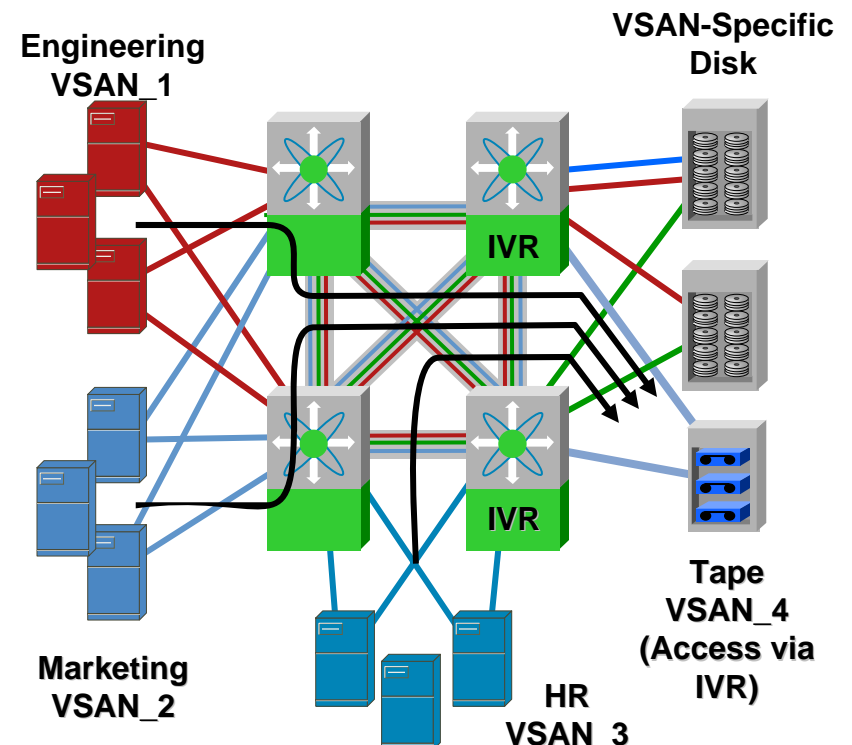
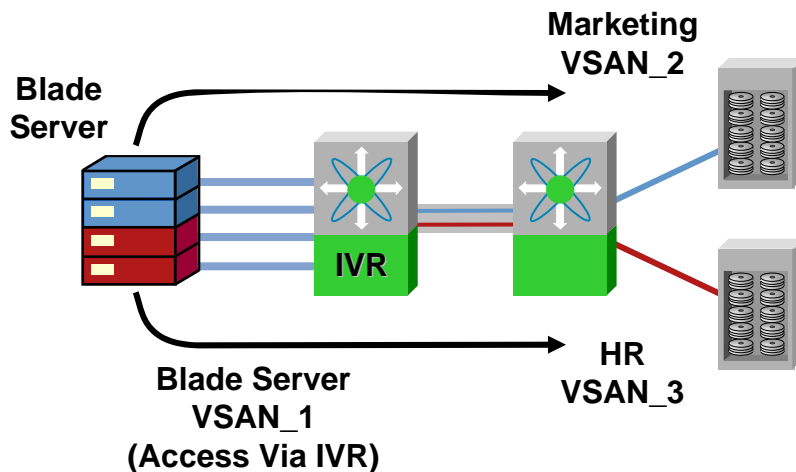

# Security Critical for SAN Consolidation

Fabric security augments overall application security

Not sufficient on its own

- Six key areas of focus

1. SAN Management Access
2. Fabric Access – secure device access to fabric service
3. Target Access – secure access to targets and LUNs
4. SAN Protocol – secure switch-to-switch communication
5. IP Storage Access – secure FCIP and iSCSI services
6. Data Integrity and Secrecy – Encryption of data in transit and at rest

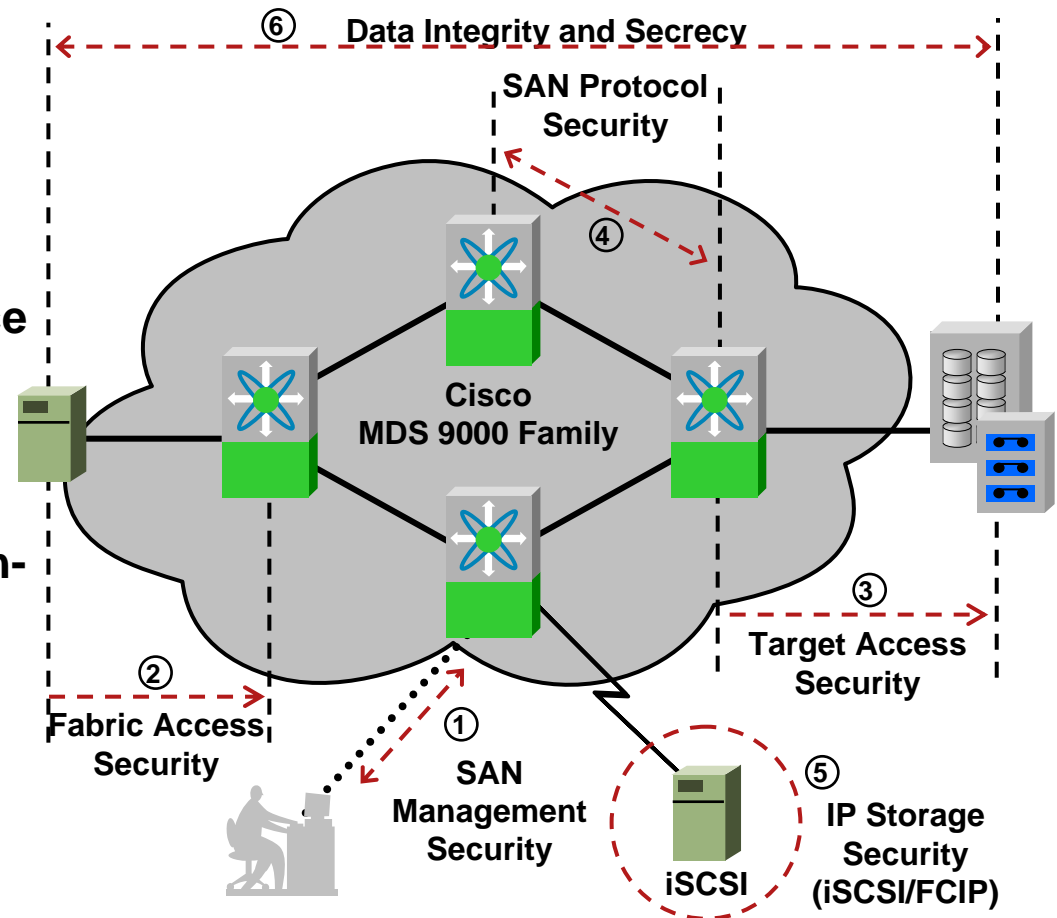

# Extending SAN Consolidation Across Data Centers

## Cisco SAN Extension Service Model

- 9 key services are required to build out reliable and flexible service
- Services are added based on application needs
- Cisco has embedded all these services into MDS 9000 platform
- Cisco extends all services across variety of transport options

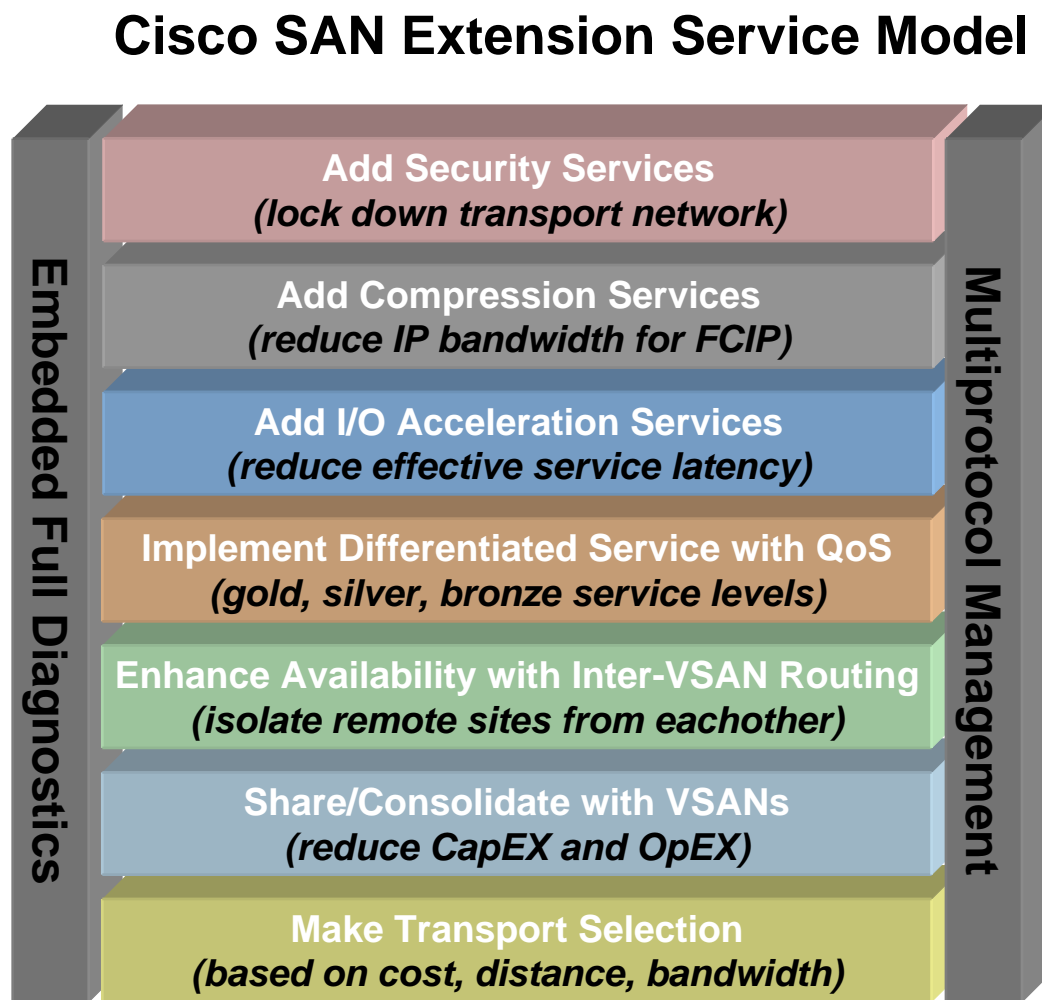

# Virtualizing the Fabric—the Full Solution

- The seven key services required to build a cost saving fabric virtualization solution:

**Virtual Fabric Attachment** —assign virtual fabric membership at the port level

**Multiprotocol Extension** —extend virtual fabric service to iSCSI, FCIP, FICON, etc.

**Virtual Fabric Services** —create fabric services per virtual fabric (routing, zones, RSCNs, QoS, etc.)

**Virtual Fabric Diagnostics** —troubleshoot per virtual fabric problems

**Virtual Fabric Security**—define separate security policies per virtual fabric

**Virtual Fabric Management** —map and manage virtual fabrics independently

**Inter-Fabric Routing** —provide connectivity across virtual fabrics—without merging the fabrics

JC1

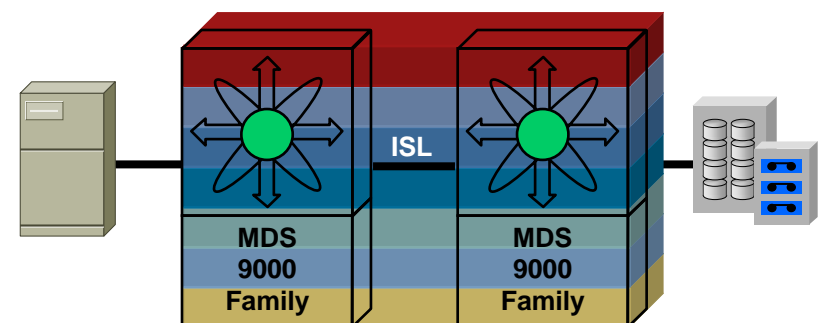
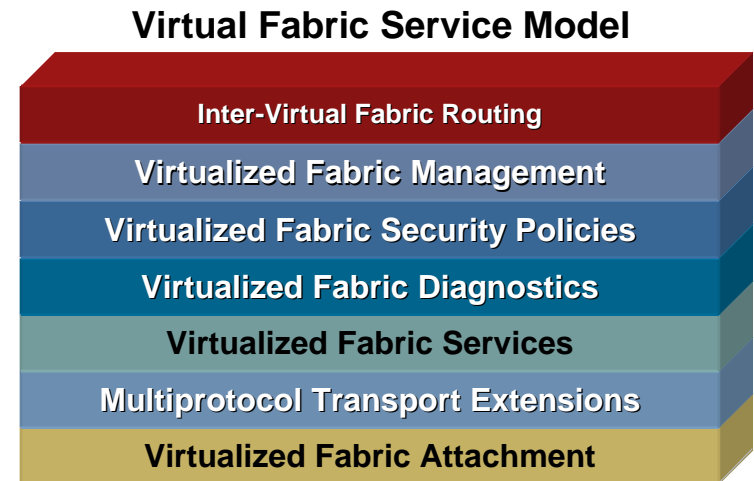

**Full Service End-to-End Virtual Fabric Implementation**

JC1

Changed sub-title from:  
To build a cost saving  
fabric virtualization solution,  
7 key services are required:

To:

The seven key services required to build a cost saving fabric virtualization solution:

Joe Childs, 10/28/2005

# Virtual SANs—Cisco MDS 9000 Family

- Each port on the MDS 9000 Family exists in a VSAN
- Up to 256 VSANs in a single switch (hardware can support up to 4095)
- Logical configuration to move a port from one fabric to another
- WWN-based VSANs can provide automated VSAN membership
- Basis for Virtual Fabric Trunking (VFT) Extended Header (ANSI T11 FC-FS-2 section 10.3)



# Virtualized Fabric—Basis for Applications

- The consolidated SAN, using VSAN technology, serves as base for the addition of intelligent storage applications
- Services can be added and securely shared amongst virtual fabrics
- Hardware acceleration of services enables scaling to large number of servers and storage arrays

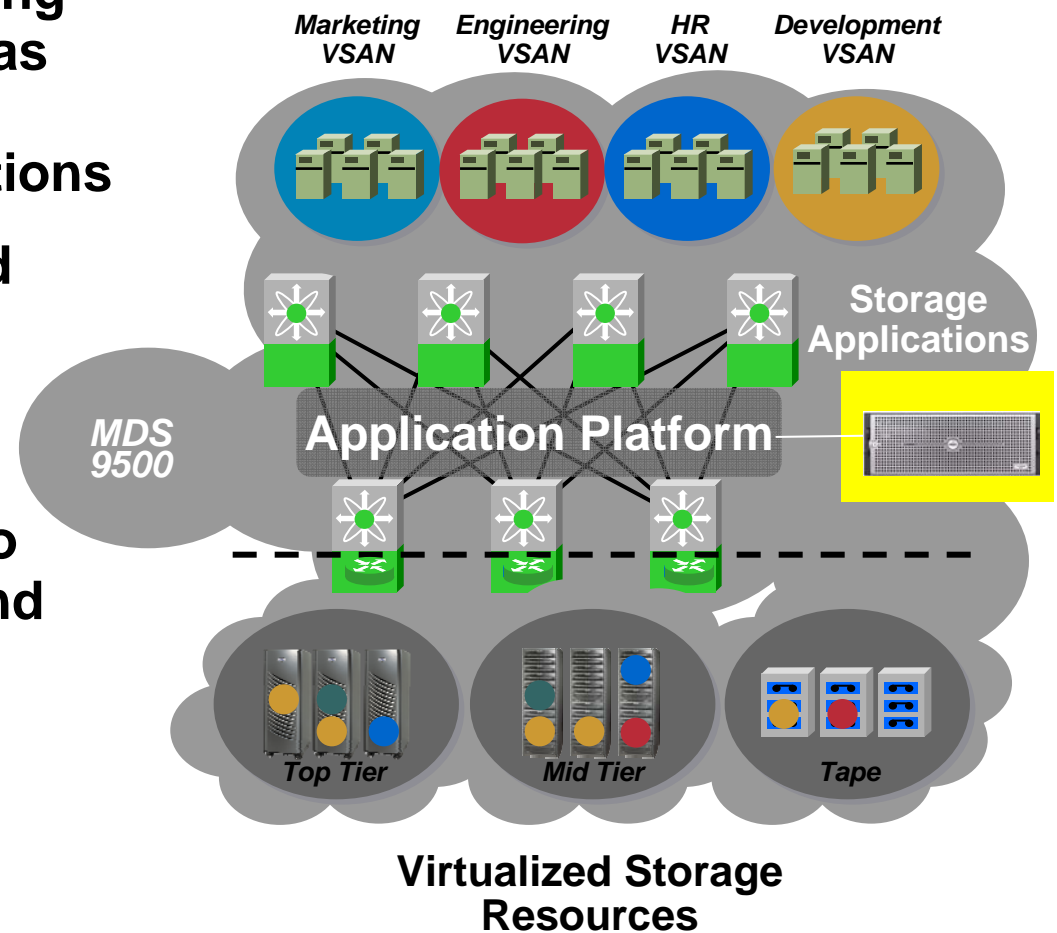

# Agenda

- Storage Challenges and Trends
- Cisco Storage Consolidation Solutions
- **Cisco Storage Virtualization Solutions**
- Summary

# Cisco Storage Virtualization Solutions

- Virtualization of the SAN and Storage environments offers relief for many IT challenges:

**Infrastructure Efficiency** — virtualization provides a means to optimize and repurpose unused resources on demand

**Technology Refreshes** — virtualization provides a means to move data from array to array without application disruption

**Provisioning Efficiency** — virtualization provides a means to provision dynamically an application's storage environment



# SAN Deployments Before Virtualization

## Host

- Individually managed
- Mirroring, striping, concatenation coordinated with disk array groupings

- Mirror, stripe, concat, slice
- Coordinated across hosts
- Application integration
- Multi-pathing

## Disk Array

- Individually managed
- Just-in-case provisioning
- Stranded capacity
- Snapshot within a disk array (same class of storage)
- Array-to-Array replication

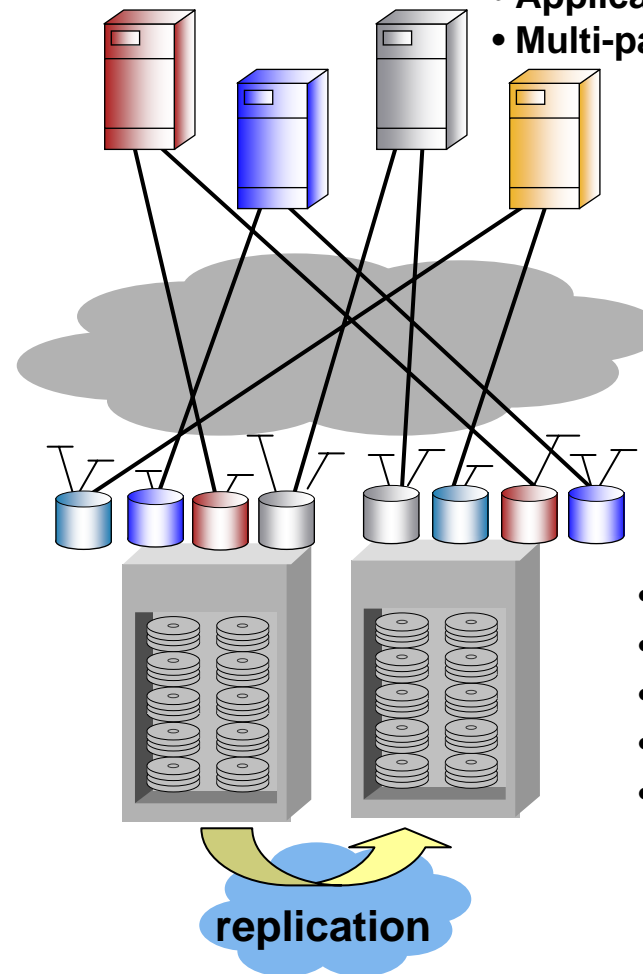

- RAID
- HA upgrades
- Multiple paths
- Snapshot
- Box-to-box replication

# Benefits of Network-Hosted Virtualization

## Solution

- **Single point of management**
- **Capacity-on-demand increases utilization**
- **Insulates servers from storage changes**
  - Migration
  - Highly available storage upgrades
- **Consolidation: Legacy investment protection**
- **Different class of storage for different purposes**
- **Enabler for simplified data protection**
  - Point-in-time copy
  - Replication

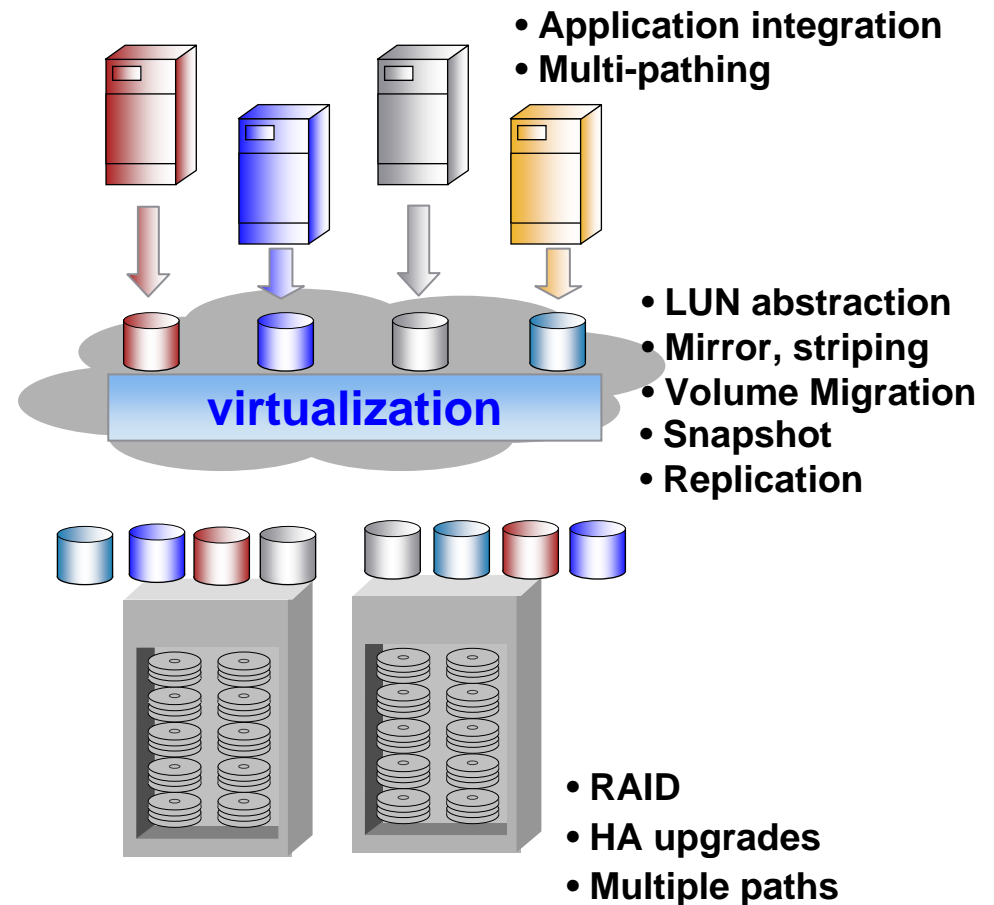

# Volume Management

- **Volume management**
  - Centralized management
  - Optimized utilization
  - Flexible provisioning
  - Workload rebalancing without host impact
- **Users can continue to access data while:**
  - Redistributing data across disks
  - Changing RAID configuration and characteristics

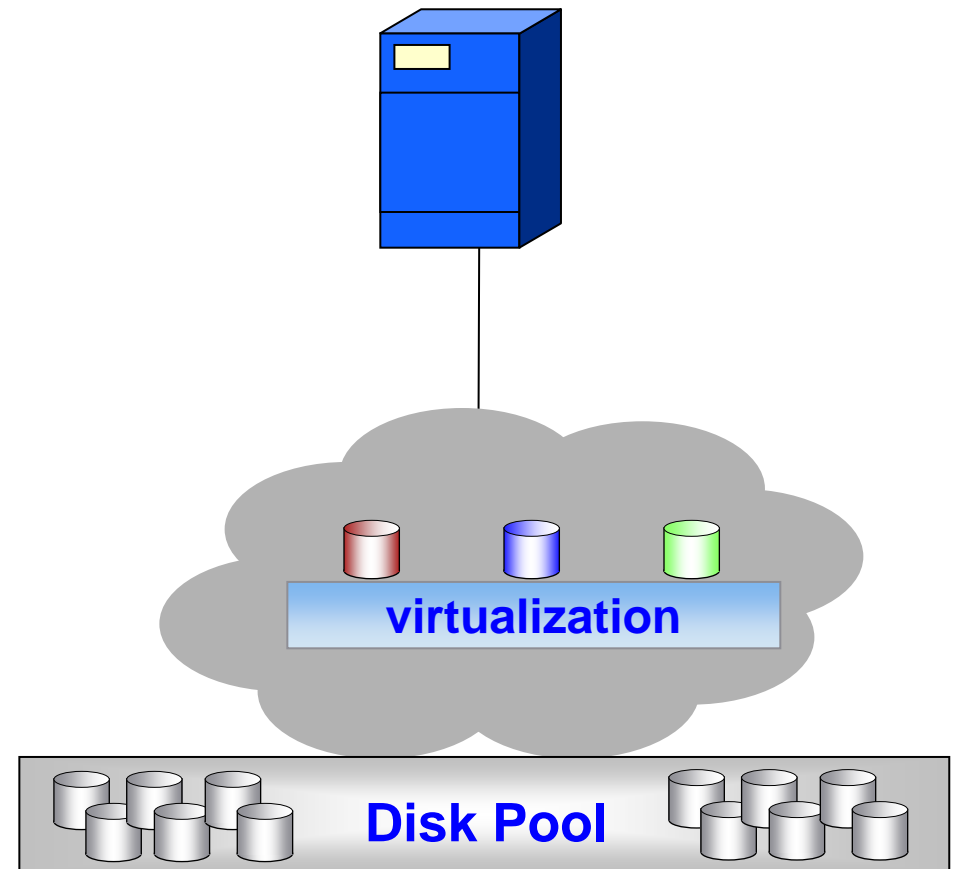

# Tiered Storage

- Tiered Storage

Organize underlying storage according to SLAs

Allocate appropriate class of storage to application

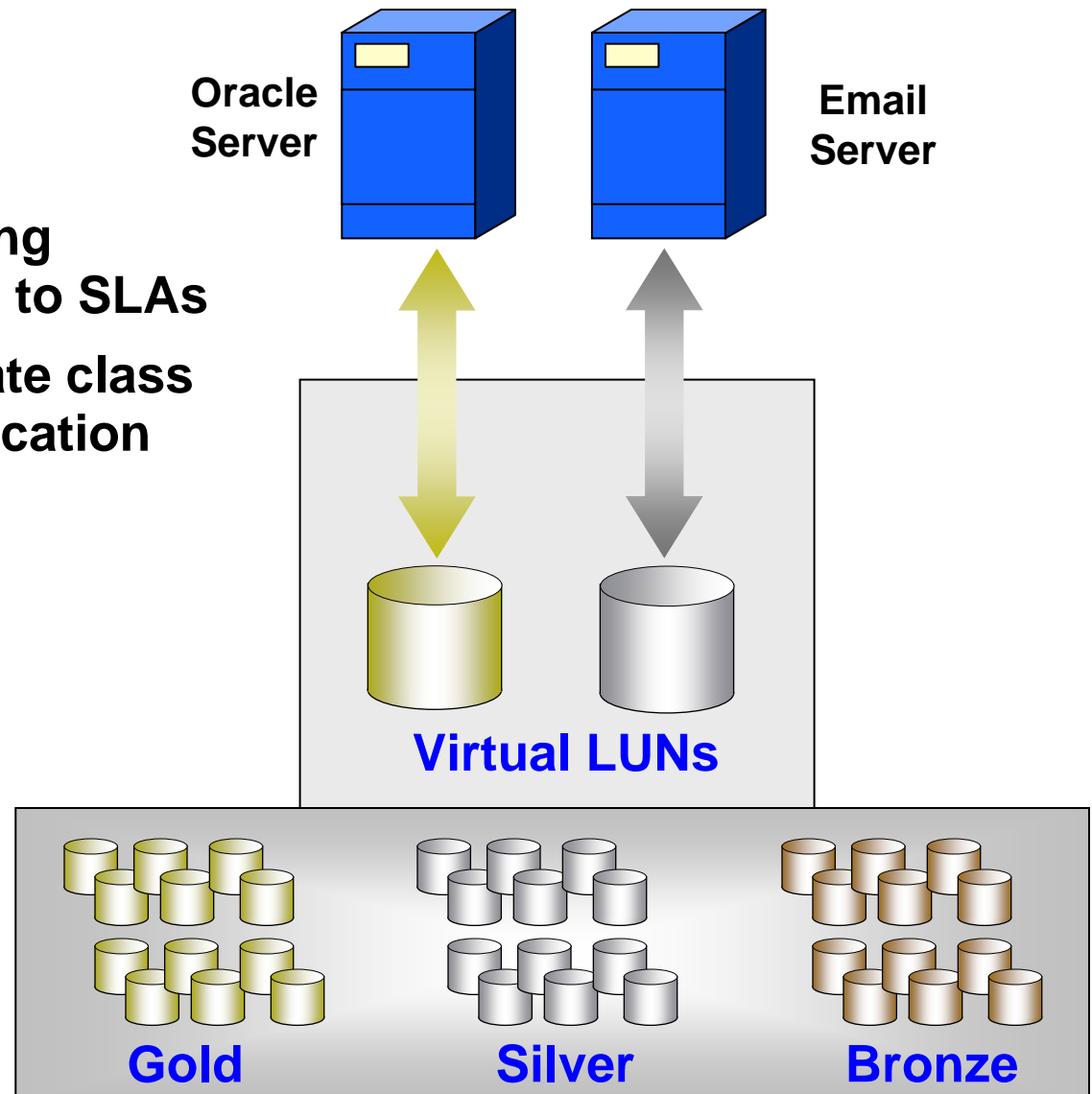

# Dynamic Volume Migration

- Non-disruptive movement of production data across storage

**Lease Roll-over**

**Seamlessly upgrade storage**

**Reconfigure storage to meet SLA objectives**

**Data Center migration/  
additions**

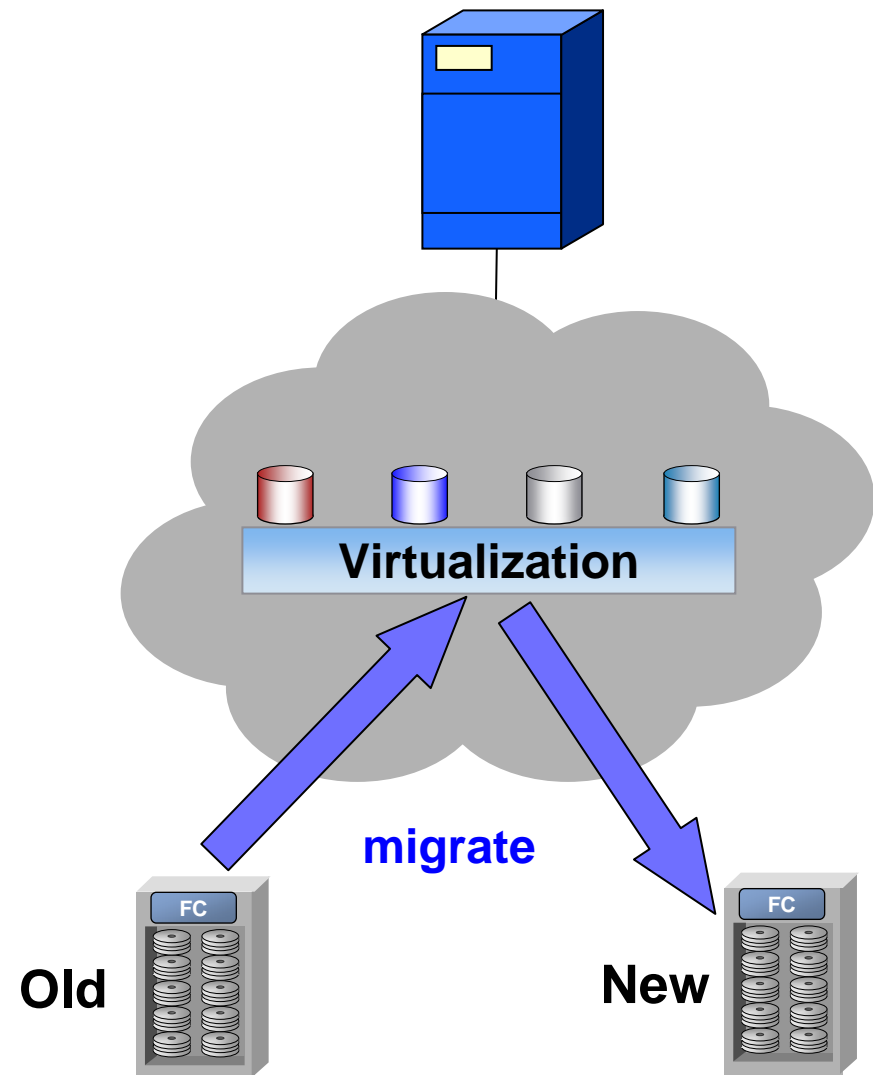

# Point-in-Time Copies

- **Point-in-time copy for backup, development, testing, and reporting**
  - Works across multiple arrays**
  - Allocate any class of storage for the clones**
  - Common set of commands**

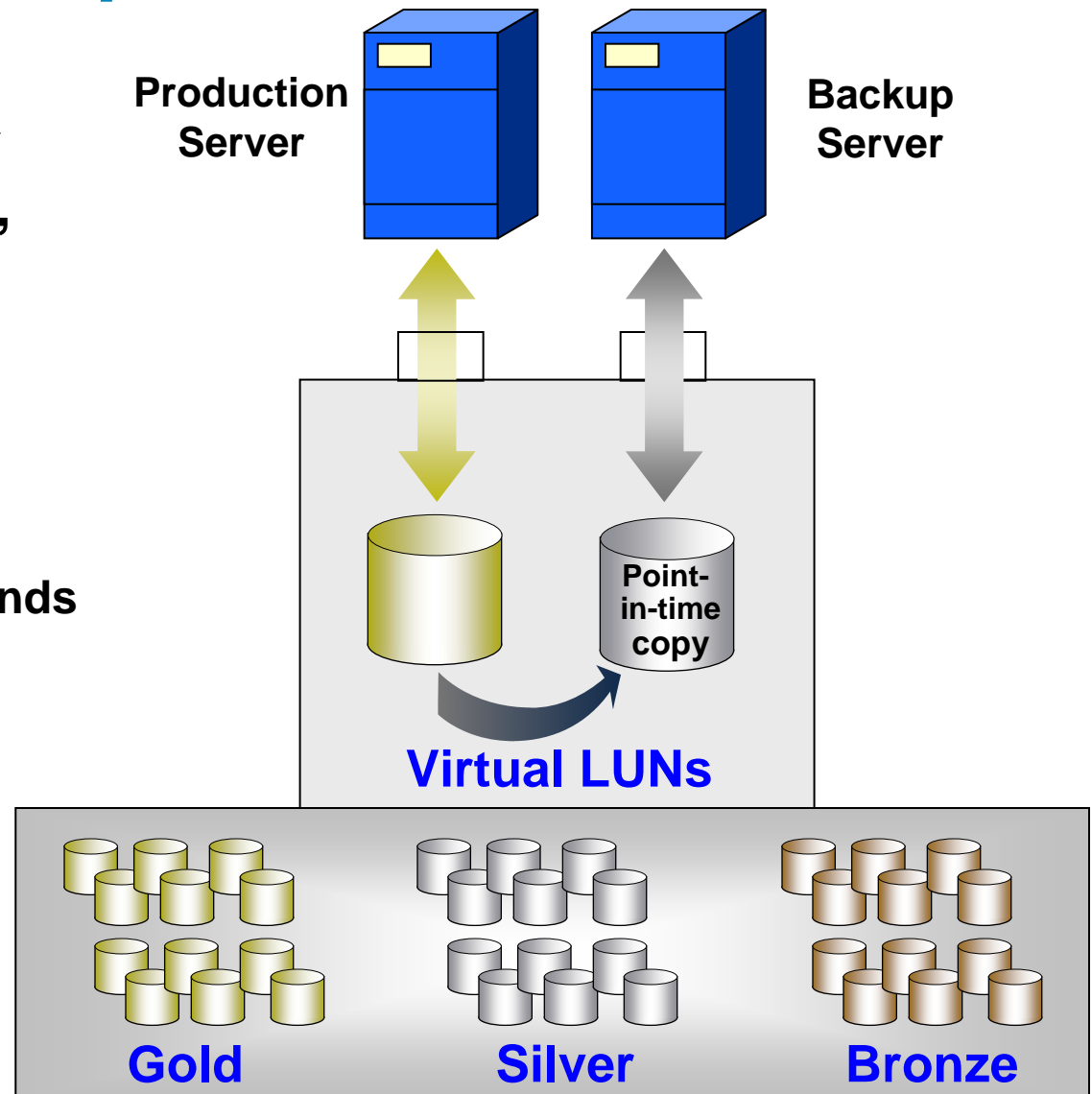

# Application and Service Convergence with Fabric-Based Virtualization Design

## Challenge: Optimize Storage Usage While Supporting Heterogeneous Storage

- Virtual targets with virtual LUNs are built from discovered physical storage
- Virtual LUNs and targets can be zoned to destined host(s)
- Separate VSAN used to isolate physical storage
- Virtualize across multiple vendors' storage arrays
- Cisco working with several partners to deliver solutions

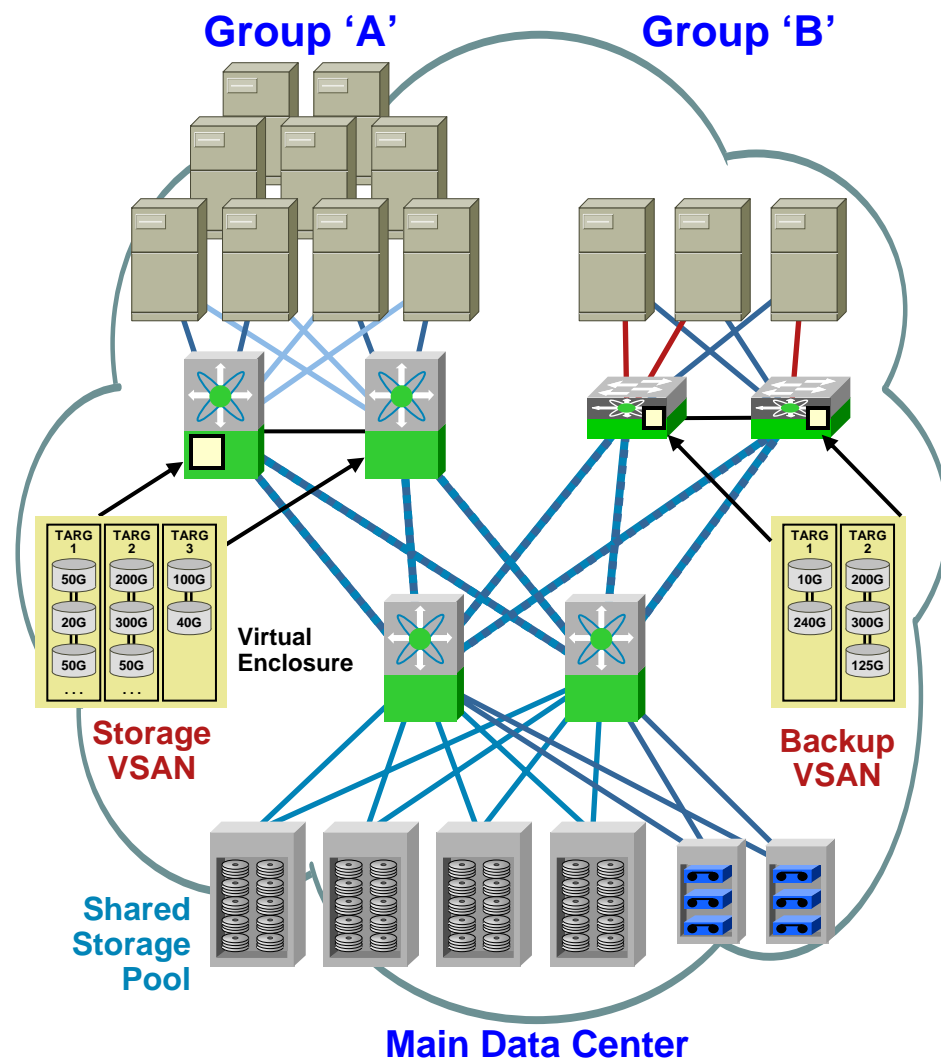

# “Network-Hosted” Storage Applications: Standards-Based, Open API

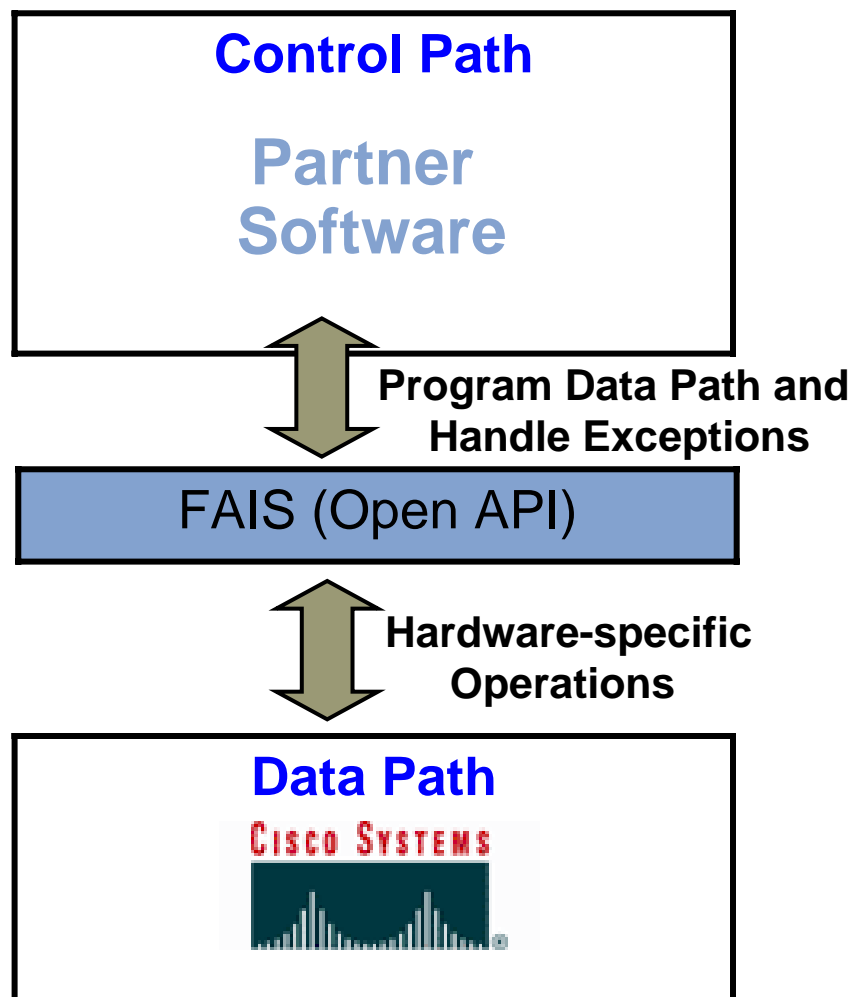

- Fabric Application Interface Specification (FAIS)  
**Standards-based (T11), open-API**  
**Chaired and Co-authored by Cisco**
- Enables Cisco to host partner applications with an open interface
- Enables Cisco’s partners to write storage applications that are switch independent

# Virtualization for Cisco MDS 9000

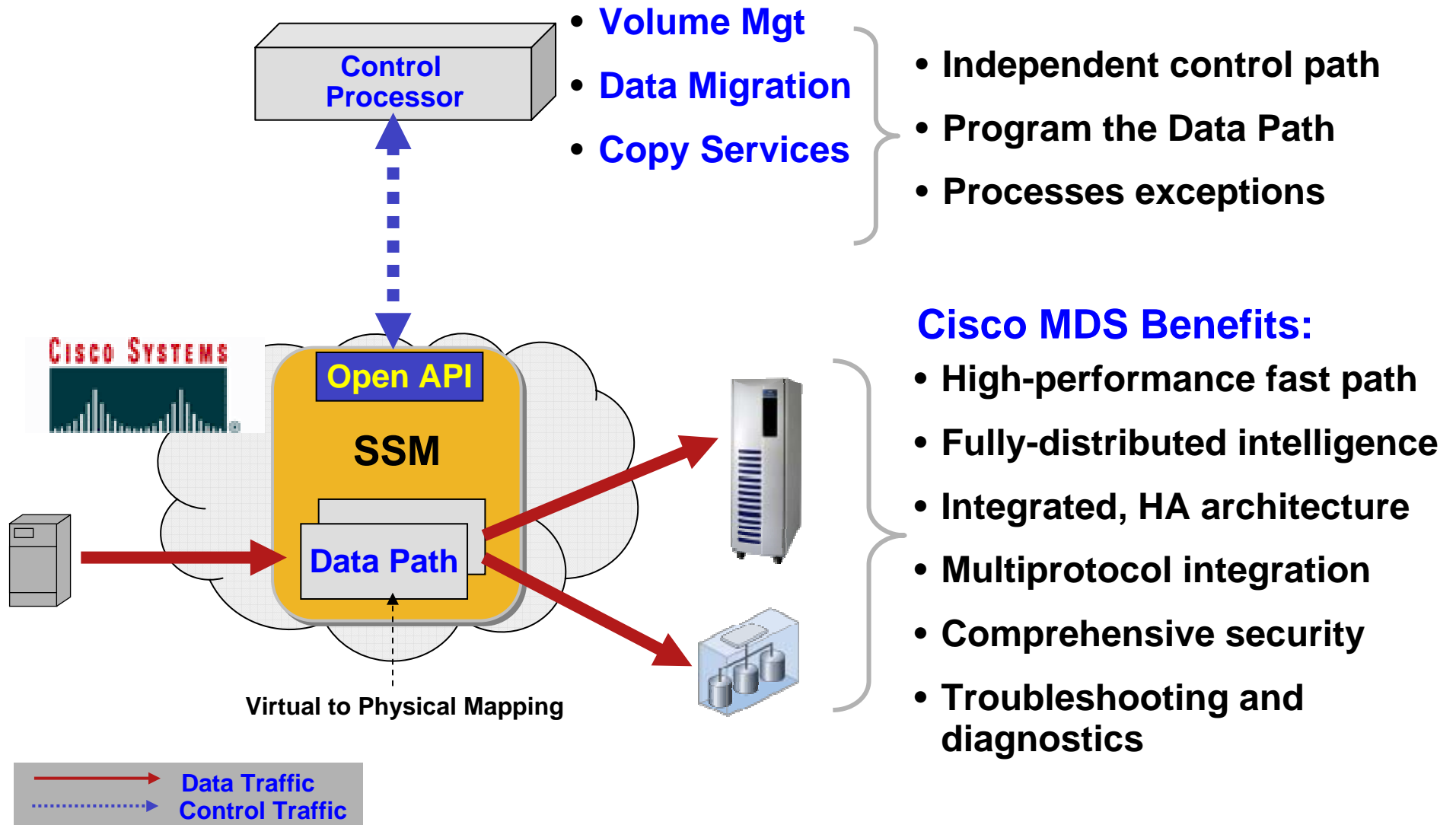

# Agenda

- Storage Challenges and Trends
- Cisco Storage Consolidation Solutions
- Cisco Storage Virtualization Solutions
- **Summary**

# Presenting the Cisco MDS 9000 Family

Industry Leading Investment Protection Across a Comprehensive Product Line

MDS 9509 Director

MDS 9513 Director

MDS 9216 and 9216i Modular Fabric Switches

MDS 9506 Director



MDS 9124 Fixed Fabric Switches



MDS 9000 Family

4G Fibre Channel/FICON

Multiprotocol

Virtualization

MDS 9000 Modules

12 Port Fibre Channel

4 Port IP Storage

Storage Services Module

24 Port Fibre Channel

48 Port Fibre Channel

14+2 Port FC+IP Storage

8 Port IP Storage

One high powered module  
Multiple supported services

Mgmt

Cisco Fabric Manager

OS

MDS 9000 Family-OS

# Cisco Delivers Storage Networking Innovation

- **Multiprotocol support** including Fibre Channel, iSCSI, FCIP, and FICON for flexible connectivity options
- **Virtual SAN (VSAN) and Inter-VSAN Routing** enabling scalable SAN design, growth, and management
- **Quality of Service (QoS)** delivering advanced traffic management
- **Diagnostic and troubleshooting tools** including FC Ping, Traceroute, SPAN, hot-spot and historical performance analysis
- **Comprehensive security** including role-based access control, AAA RADIUS and TACAS+, SSH, SFTP, SNMPv3, FC-SP
- **Network-hosted storage applications, such as virtualization,** for improved operational efficiency



