

ISP Infrastructure & Operational Security



Dirk Schroetter, Consulting Systems Engineer

Welcome to the Human Network.

Agenda

- Security Overview and Process
- Securing the Router
- Securing the Management Plane
- Securing the Control Plane
- Securing the Data Plane
- Staying informed
- Q&A
- References

Credits

- This presentation is based on material from a number of esteemed colleagues in Cisco and in the field at large. My gratitude to them for their excellent material.
- Special thanks to:
 - Michael Behringer
 - Gregg Schudel
 - Dawit Birhanu
 - David Barak
 - Barry Raveendran Greene
 - Mark Prior

Security Overview & Process



Welcome to the Human Network.

Everything you need to know on 1 slide

- Security is a process as well as a craft & discipline
- Defense at the edge is dead -> defense in the deep
- There are many resources out there -> stay informed
- Expect things to break -> be paranoid

Defence in the deep

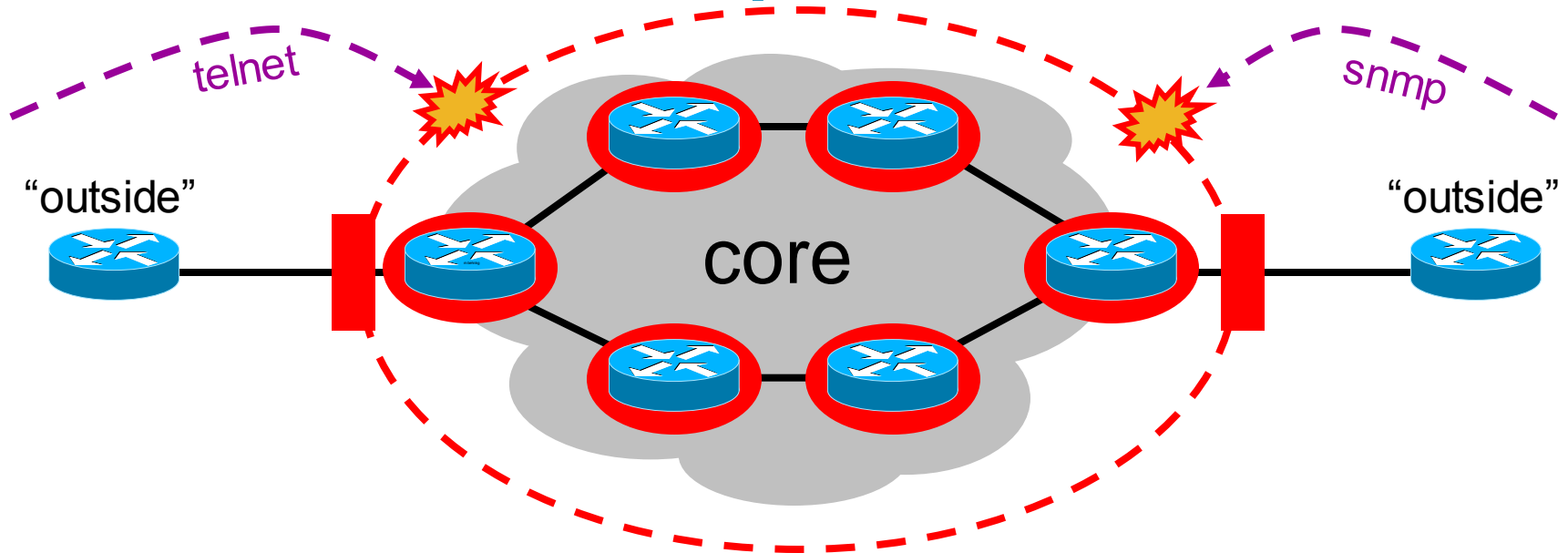

- Core routers individually secured PLUS
- Infrastructure protection
- Routers generally NOT accessible from outside

Securing the Router



Welcome to the Human Network.

Securing the Router

1. Basic Security

AAA, SSH, SNMPv3, rACL, CoPP, etc...



Individual router security

2. Don't let packets into (!) the core

→ No way to attack core, except through routing, thus:



Still "open":
routing protocol

3. Secure the routing protocol

Neighbor authentication, maximum routes, dampening, GTSM, ...



Only attack vector: Transit traffic

4. Design for transit traffic

Correct Core Design

Capacity / QoS

Choose correct router for bandwidth



Now only insider attacks possible

5. Operate Securely

Welcome to the Human Network.



Avoid insider attacks

Securing the Management Plane



Welcome to the Human Network.

Control Plane Policing

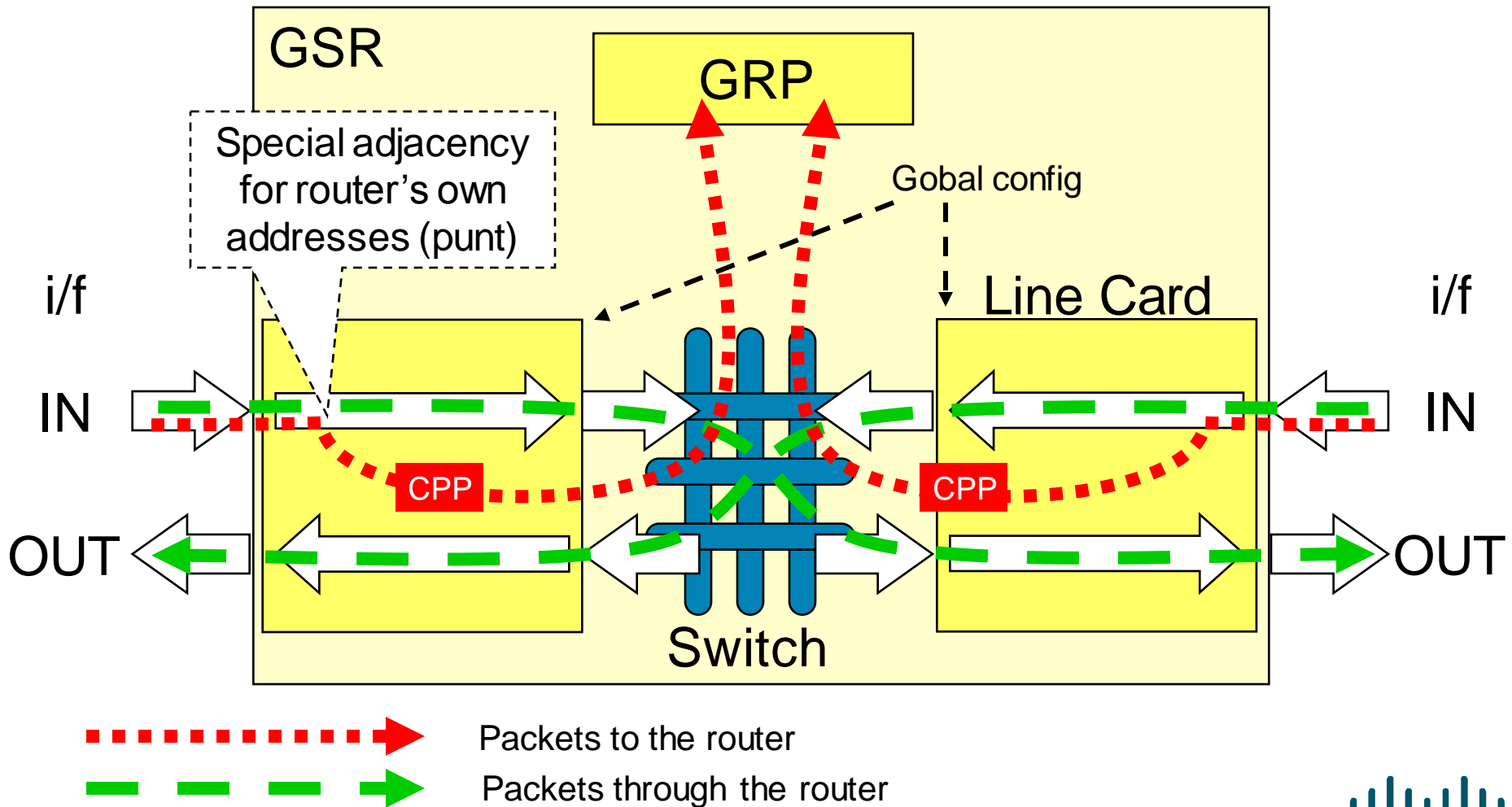

Welcome to the Human Network.



Configuring CPP

Control Plane Policing

```
Router(config)# access-list 140 deny tcp host 10.1.1.1 any eq telnet  
Router(config)# access-list 140 permit tcp any any eq telnet
```

```
Router(config)# class-map telnet-class  
Router(config-cmap)# match access-group 140  
Router(config-cmap)# exit
```

Traffic to be rate limited: All telnet but not from host 10.1.1.1

Define class-map for this traffic

```
Router(config)# policy-map control-plane-policy  
Router(config-pmap)# class telnet-class  
Router(config-pmap-c)# police 80000 conform transmit exceed drop  
Router(config-pmap-c)# exit  
Router(config-pmap)# exit
```

Define the policy for this class map: up to 80 kbps: transmit, else drop

```
Router(config)# control-plane  
Router(config-cp)# service-policy input control-plane-policy  
Router(config-cp)# exit
```

Apply policy: to control-plane

Local Packet Transport Services IOS-XR

- Why is LPTS needed?
 - LPTS enables distributed applications to reside on any or all RPs, DRPs, or LCs
 - Filters and polices local ‘for-us’ packets and sends them only to the nodes that need them
 - Re-assembling fragments
 - High Availability for NSR (Non-Stop Routing)
- LPTS has HW policers on line cards to limit traffic sent to local or remote nodes
 - LPTS entries in TCAM classifies packets to select a policer
 - Policies on protocol (BGP, OSPF, SSH) and flow state (BGP established flows, BGP listen)
 - Policing done on the LC ASIC before packets hit RP/LC CPU
 - All filters are automatically and dynamically installed by the IOS XR infrastructure

Local Packet Transport Services

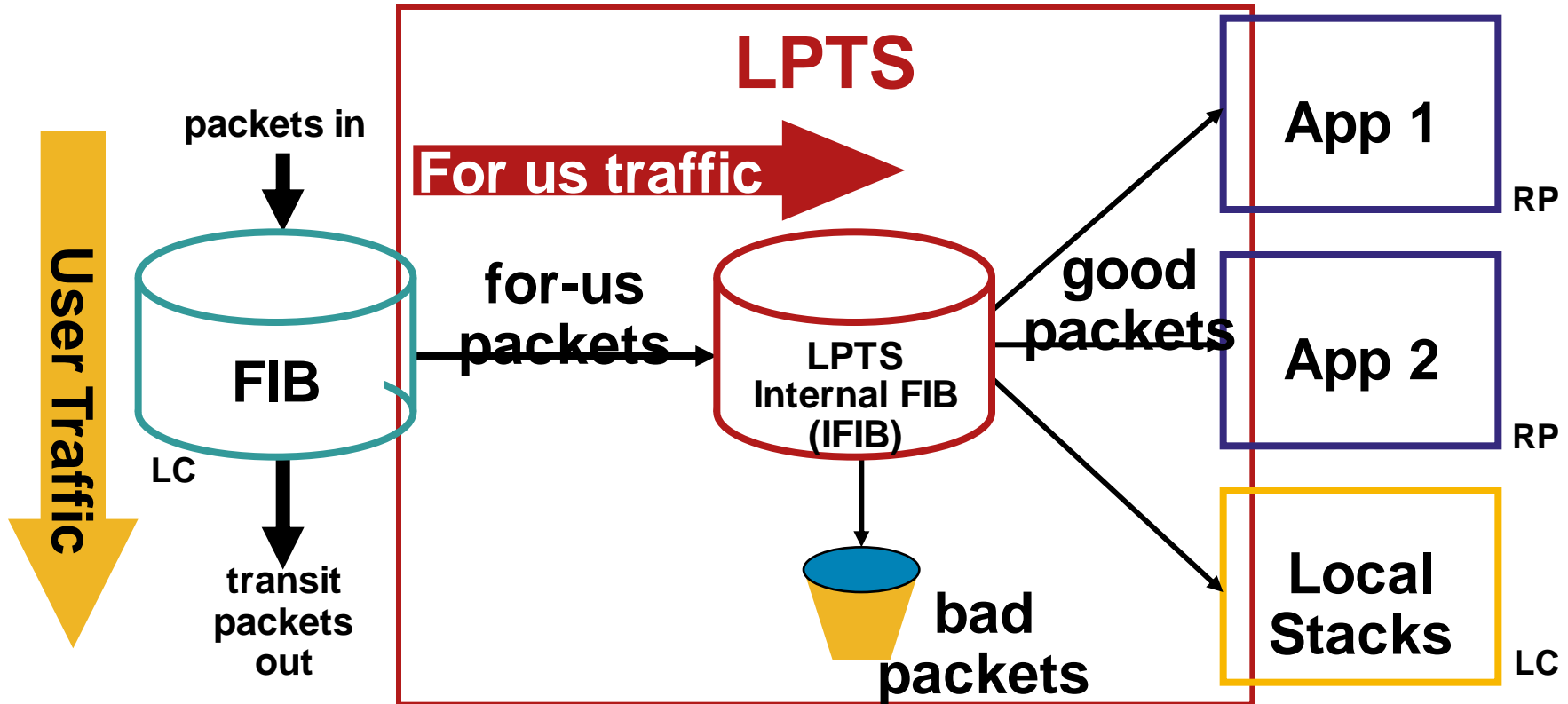

- LPTS enables applications to reside on any or all RPs, DRPs, or LCs
Active/Standby, Distributed Applications, Local processing
 - IFIB forwarding is based on matching control plane flows
Built in firewall for control plane traffic.
 - LPTS is transparent and automatic
- Welcome to the Human Network.

Securing the Control Plane



Welcome to the Human Network.

Control Plane Security

- Data plane
- Control plane
- Management plane
- Services plane

Control Plane Security Features

■ ■ ■ Receive-Path Access List (rACL)	IOS 12.0S-only ACL applied to “receive” path packets
■ ■ ■ Control Plane Policing (aCoPP and dCoPP)	IOS-wide MQC-based policing applied to all punt-path packets
■ ■ ■ ■ Selective Packet Discard (SPD)	IOS-wide “process” level queuing and packet prioritization into CPU
BGP Security-Related Commands	
■ IP Prefix List	BGP prefix filtering mechanism using a prefix-list
■ IP Community List	BGP prefix filtering mechanism using a community B
■ IP AS-Path Access Lists	BGP prefix filtering mechanism using an AS path list
■ Route Map	Method for attaching policies to BGP neighbor process
■ Class Map	MQC mechanism for expressing policy
■ Policy Map	MQC mechanism for expressing policy
■ ■ ■ ■ Static/Null0 Routes	Static route definition mechanism
■ ISIS Security-Related Commands	ISIS related security commands
■ OSPF Security-Related Commands	OSPF related security commands
■ EIGRP Security-Related Commands	EIGRP related security commands
■ RIPv2 Security-Related Commands	RIPv2 related security commands
■ LDP Security-Related Commands	LDP related security commands

Control Plane Security

- Data plane
- Control plane
- Management plane
- Services plane

Control Plane Security Features

■ RSVP Security-Related Commands	RSVP related security commands
■ PIM Security-Related Commands	PIM related security commands
■ IGMP Security-Related Commands	IGMP related security commands
■ IP icmp rate-limits	Rate limit ICMP error message generation
■ IP redirects	Toggle generation of ICMP redirect messages
■ IP unreachable	Toggle generation of ICMP unreachable messages
■ IP mask-reply	Toggle generation of ICMP mask-reply messages
■ IP information-reply	Toggle generation of ICMP information-reply messages
■ IP proxy-arp	Toggle ip proxy-arp functionality
■ Key Chain	Define key-chains (used for some routing protocol authentication mechanisms)

Securing the Data Plane



Welcome to the Human Network.

uRPF Overview

- uRPF uses information in the Forwarding Information Base (FIB) created by the Cisco Express Forwarding (CEF) switching path to perform reverse path resolution on the source IP address of an incoming packet.

The FIB table is dynamically populated from the routing information of all active routing protocols and static routes.

There is an entry for each known prefix, along with associated path(s) information.

- uRPF is superior to ingress ACLs for ingress anti-spoofing protection
 - It's dynamic and automatically updated
 - It's operationally simple to maintain and scale
 - Minimal performance impact (it's in the fast path)

uRPF Basic Operations

- uRPF “Strict Mode” (aka “version 1”)

Requires the existence of a valid FIB path entry via the exact same interface as that on which the packet arrived for the source IP address of an incoming packet.

If the FIB return path does not exist, or refers to a different interface than the one on which the packets arrived, the packet is dropped.

- uRPF “Loose Mode” (aka “version 2”)

Requires the existence of a valid FIB path entry via any interface for the source IP address of an incoming packet (i.e. the strict interface adherence is no longer enforced).

If a valid FIB entry does not exist, or if the FIB entry refers to the Null0 interface, the packet is dropped.

- uRPF “VRF Mode” (aka “version 3”)

Requires that the source IP address of the incoming packet exist or not exist (depending on the mode selected – white list or black list mode) within the prefix list contained within the designated VRF.

[Note: this uRPF v3 availability is limited to certain C12K images and only Engine 0 Line Cards to date.]

uRPF Basic Operations “strict mode” vs. “loose mode”

```
router(config-if)# ip verify unicast source reachable-via rx
```

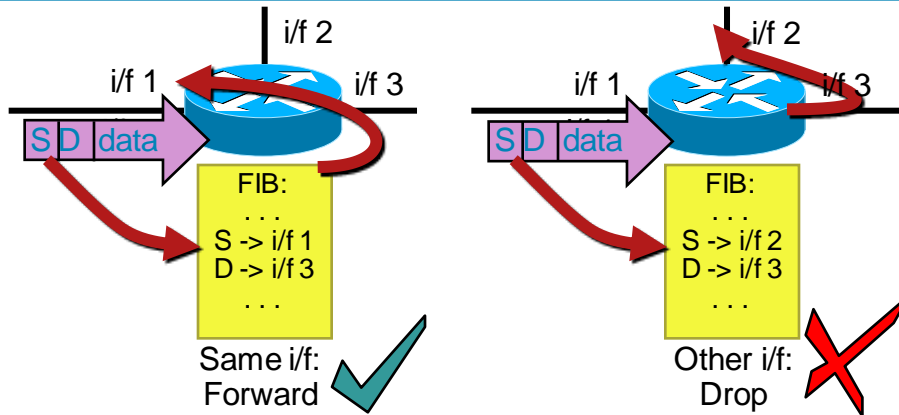

“Strict Mode”
(aka “v1”)

```
router(config-if)# ip verify unicast source reachable-via any
```

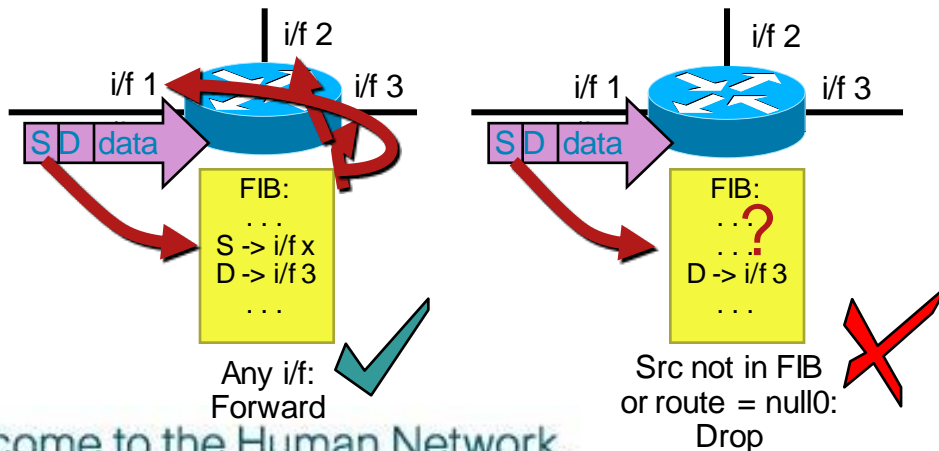

“Loose Mode”
(aka “v2”)

uRPF Overview

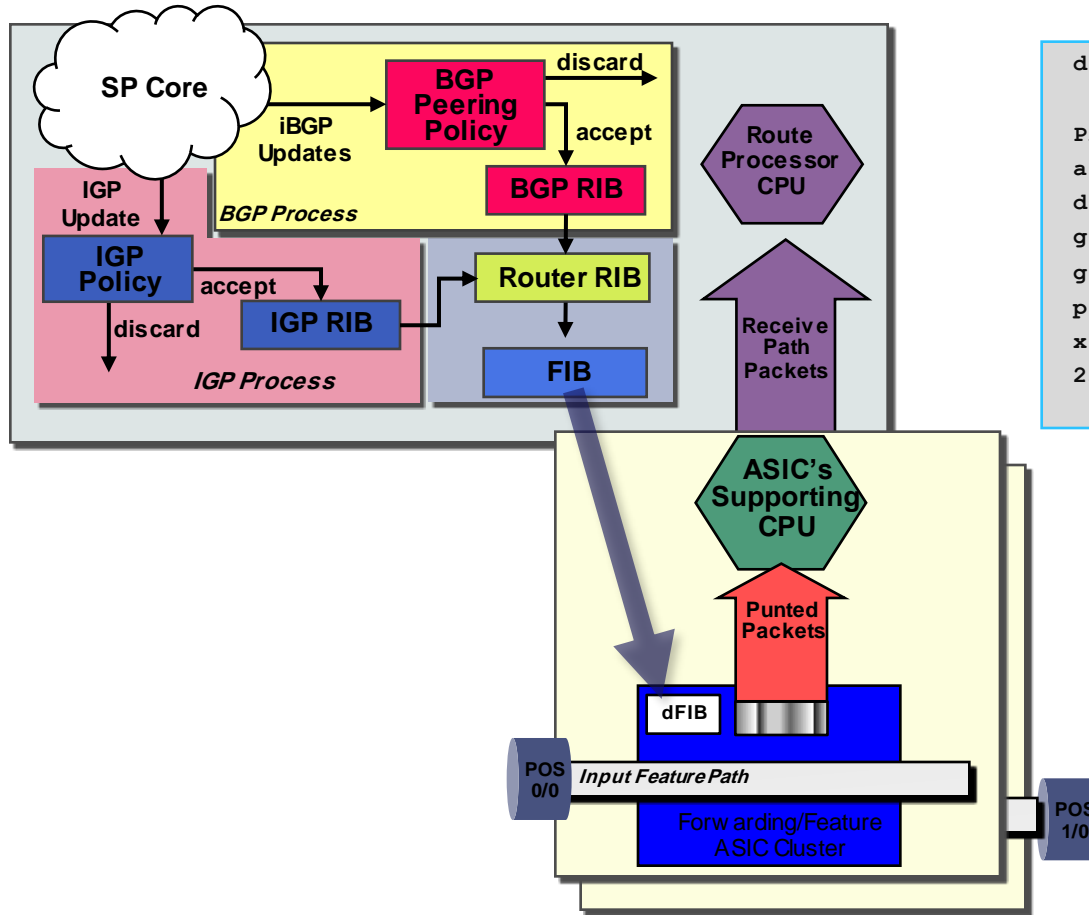

Prefix	Next Hop	Interface
a.b.c.0/24	1.1.1.1	POS0/0
d.e.f.0/24	2.2.2.2	POS1/0
g.h.i.0/30	attached	POS0/0
g.h.i.1/32	receive	
p.q.r.s/32	attached	Null0
x.y.z.0/24	2.2.2.2	POS1/0
255.255.255.255/32	receive	

uRPF "Strict Mode"

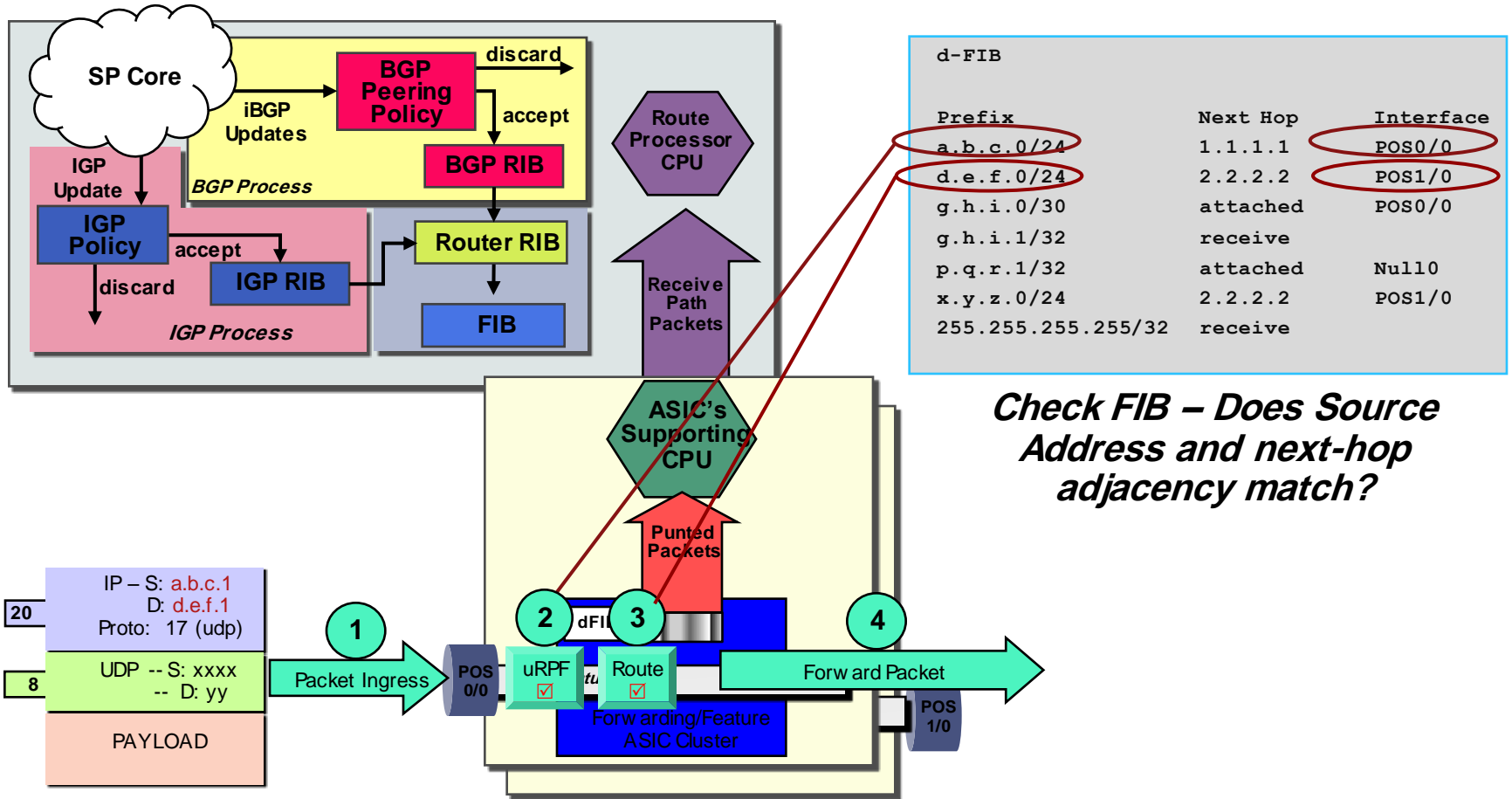

```
router(config)# int pos0/0
router(config-if)# ip verify unicast source reachable-via rx
```

Welcome to the Human Network.



uRPF "Loose Mode"

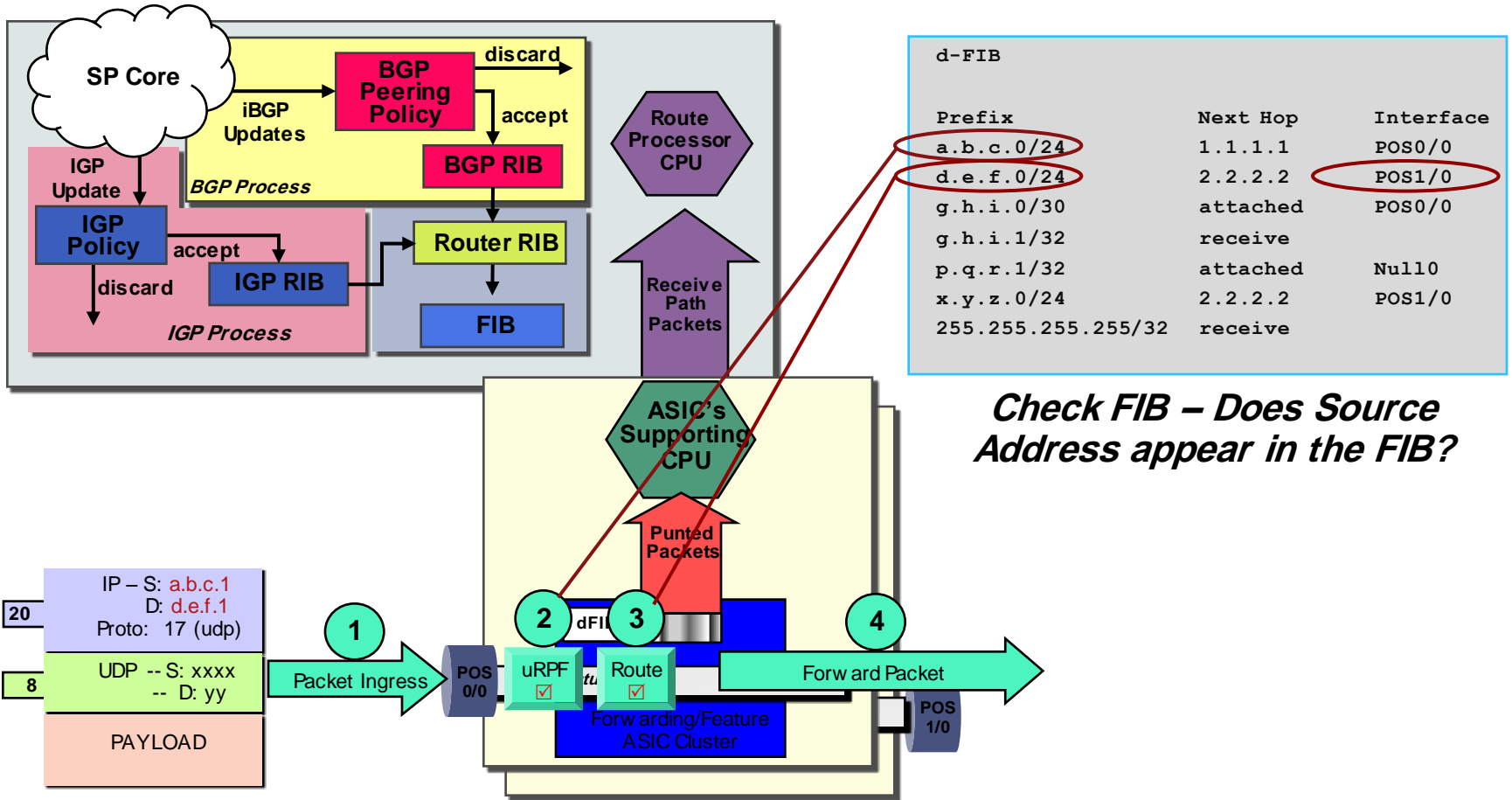

```
router(config)# int pos0/0
router(config-if)# ip verify unicast source reachable-via any
```

Welcome to the Human Network.



Where To Deploy uRPF? Service Provider Configuration

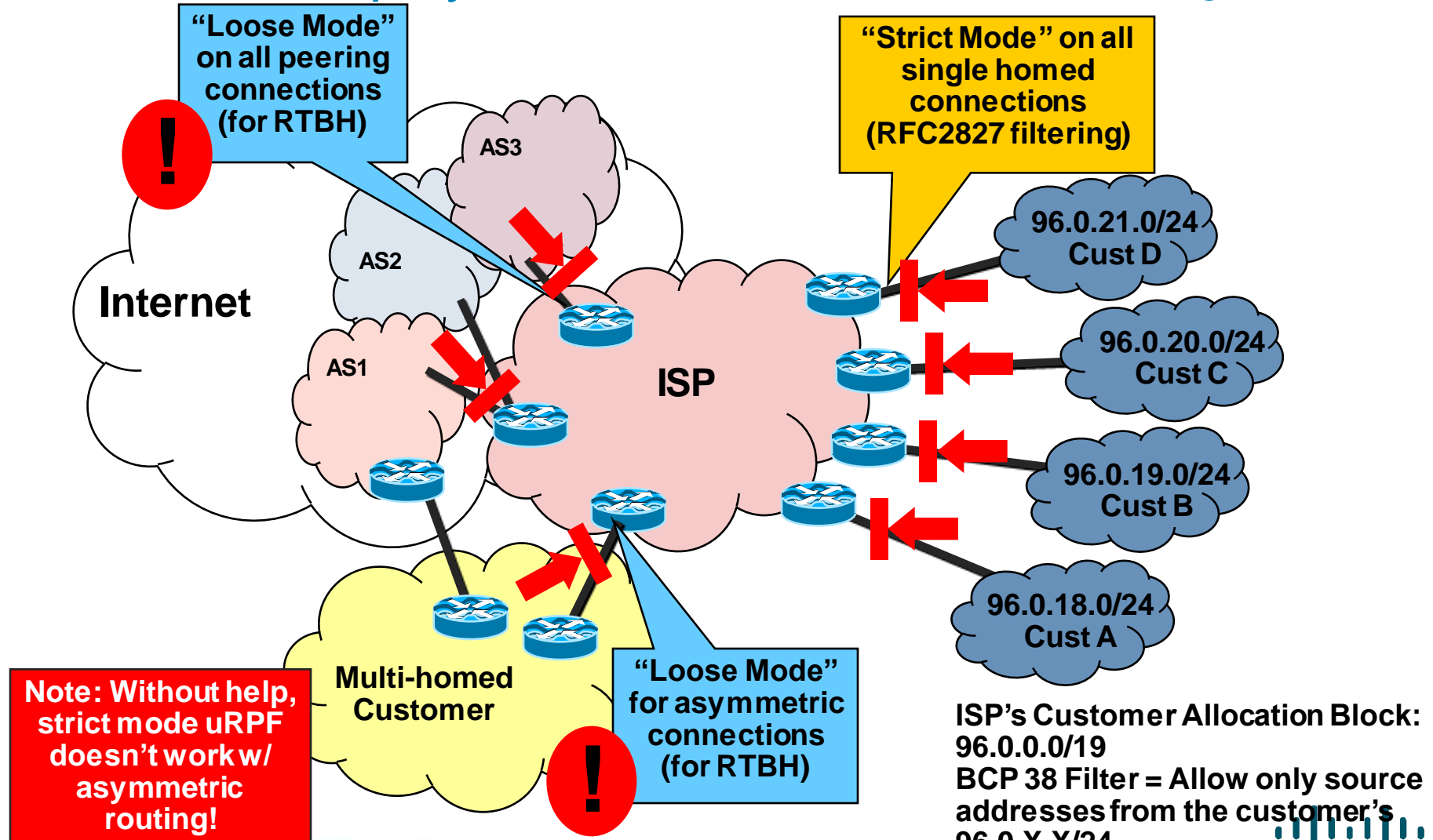

Welcome to the Human Network.

Remote Triggered Black Hole (RTBH) Filtering

What Is It?

- Remotely Triggered Black Hole (RTBH) filtering is an **SP network foundation tool**

RTBH provides a reaction technique for security events (e.g. DoS/DDoS attacks) that enables network-wide destination and source IP address –based drop capabilities

- RTBH Uses BGP to trigger network-wide attack flow responses

Simple pre-configured static route allows the SP to trigger network-wide destination-based black holes at iBGP update speeds

Coupling with Unicast Reverse Path Forwarding (uRPF) enables network-wide source-based triggered black holes, including at the ISP—ISP edge

Effective against spoofed and valid source addresses

- Preparation does not adversely impact SP operations or router performance

Reacting to an Attack with RTBH

What's Needed?

- Pre-configured static route to Null0 for a /32 address from TEST-NET (192.0.2.0/24) on all border/edge routers
- Unicast Reverse Path Forwarding (uRPF) strict or loose mode on all border/edge routers (optional – for source-based RTBH)
- Method to inject a BGP advertisements into the network with a tag or community to trigger the drop
 - Include the no-export, no-advertise communities, and good egress route-filters to prevent leakage
- A way to quickly identify and classify the attack traffic
 - NetFlow and Narus, Arbor, or other

RTBH: Global and Regional Deployment

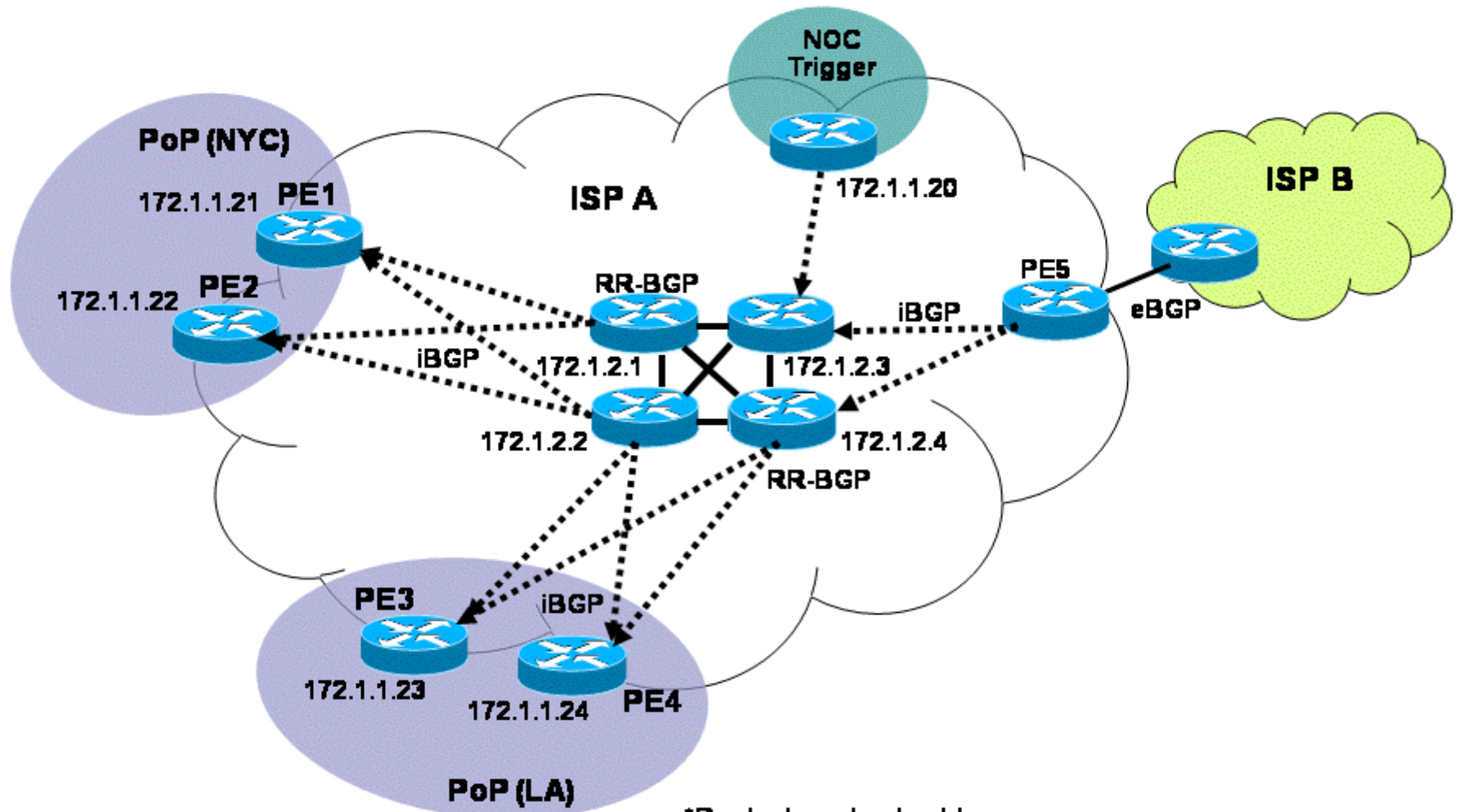

*Router Loopback address

RTBH: Basic Tag-Based Dst Drops

Trigger router pre-configuration

```
!  
hostname trigger  
ip bgp-community new-format  
!  
interface Loopback0  
ip address 172.1.1.20 255.255.255.255  
!  
router bgp 1  
no synchronization  
bgp router-id 172.1.1.20  
bgp log-neighbor-changes  
redistribute static route-map RTBH-trigger  
neighbor 172.1.2.3 remote-as 1  
neighbor 172.1.2.3 update-source Loopback0  
neighbor 172.1.2.3 version 4  
neighbor 172.1.2.3 route-map no-prefix-in in  
no auto-summary  
!  
ip prefix-list no-in seq 5 deny 0.0.0.0/0  
ip route 192.0.2.1 255.255.255.255 Null0  
!  
route-map no-prefix-in permit 10  
match ip address prefix-list no-in  
!  
route-map RTBH-trigger permit 10  
match tag 666  
set ip next-hop 192.0.2.1  
set local-preference 200  
set origin igp  
set community no-export  
!
```

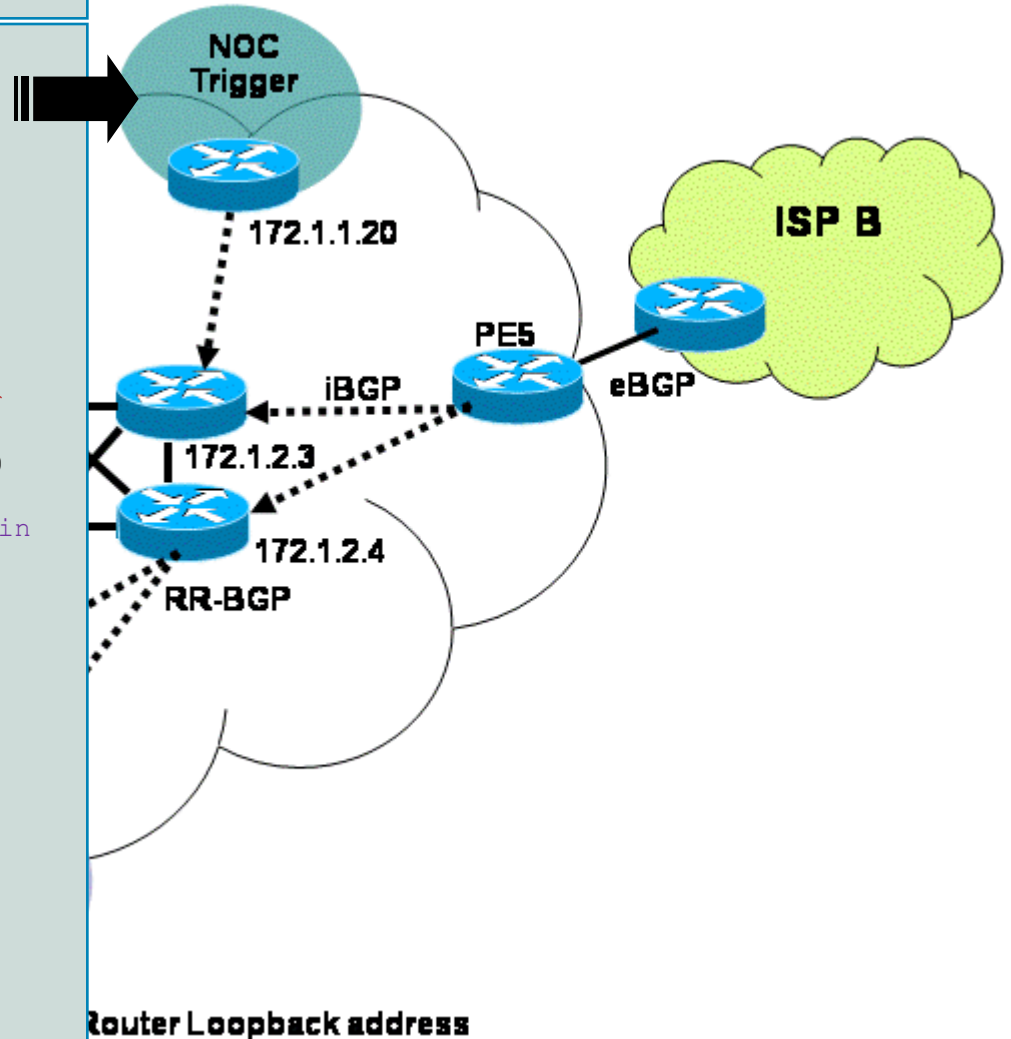

RTBH: Basic Tag-Based Dst Drops

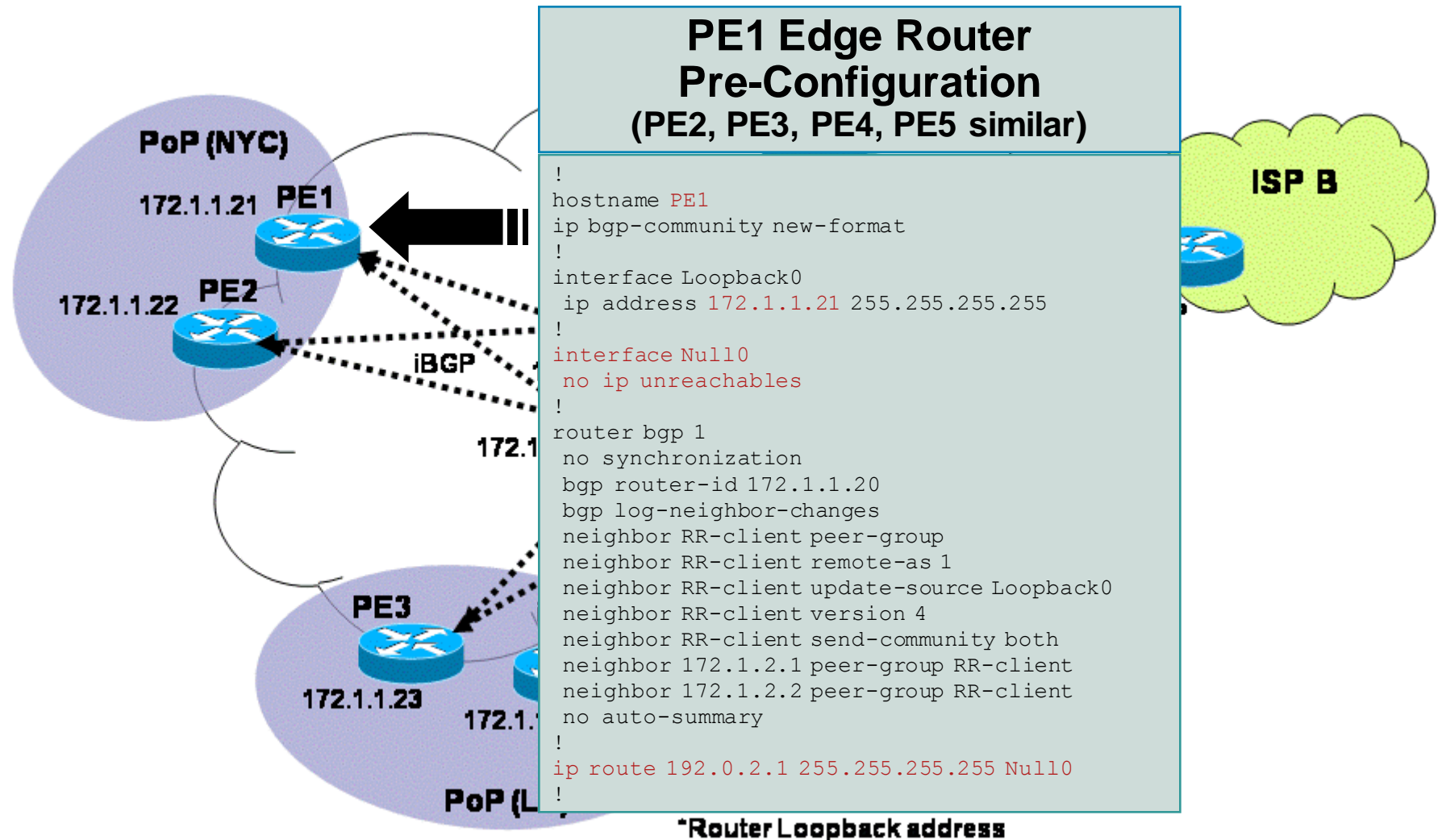

RTBH: Global and Regional Deployment

Example: Basic Tag-Based Dst Drops

```
trigger(config)#ip route 192.168.1.100 255.255.255.255 null0 tag 666
```

Attack:
SRC:10.1.1.1
DST:192.168.1.100

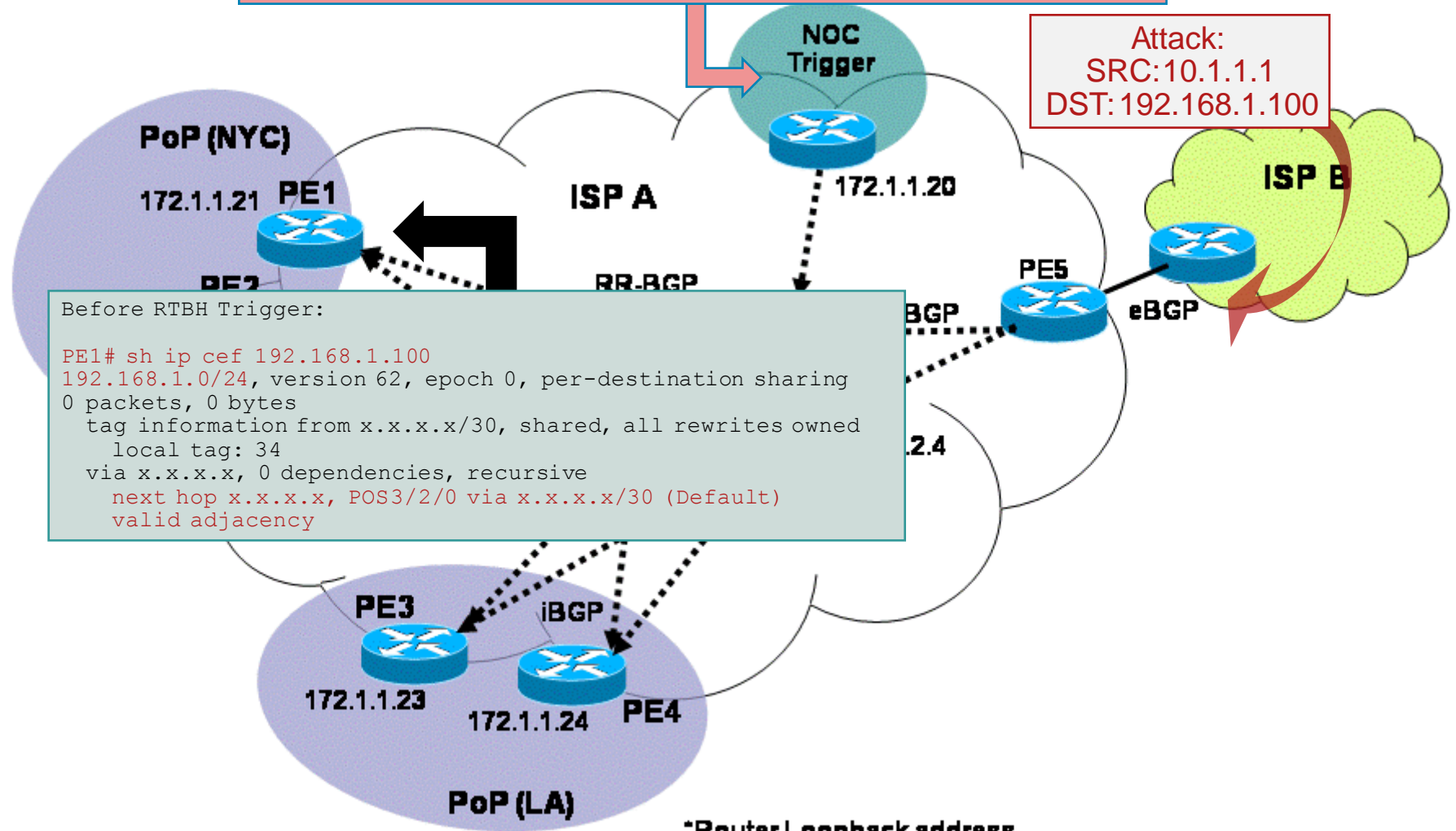

Before RTBH Trigger:

```
PE1# sh ip cef 192.168.1.100
192.168.1.0/24, version 62, epoch 0, per-destination sharing
0 packets, 0 bytes
tag information from x.x.x.x/30, shared, all rewrites owned
local tag: 34
via x.x.x.x, 0 dependencies, recursive
next hop x.x.x.x, POS3/2/0 via x.x.x.x/30 (Default)
valid adjacency
```

*Router Loopback address

RTBH: Global and Regional Deployment

Example: Basic Tag-Based Dst Drops

```
trigger(config)#ip route 192.168.1.100 255.255.255.255 null0 tag 666
```

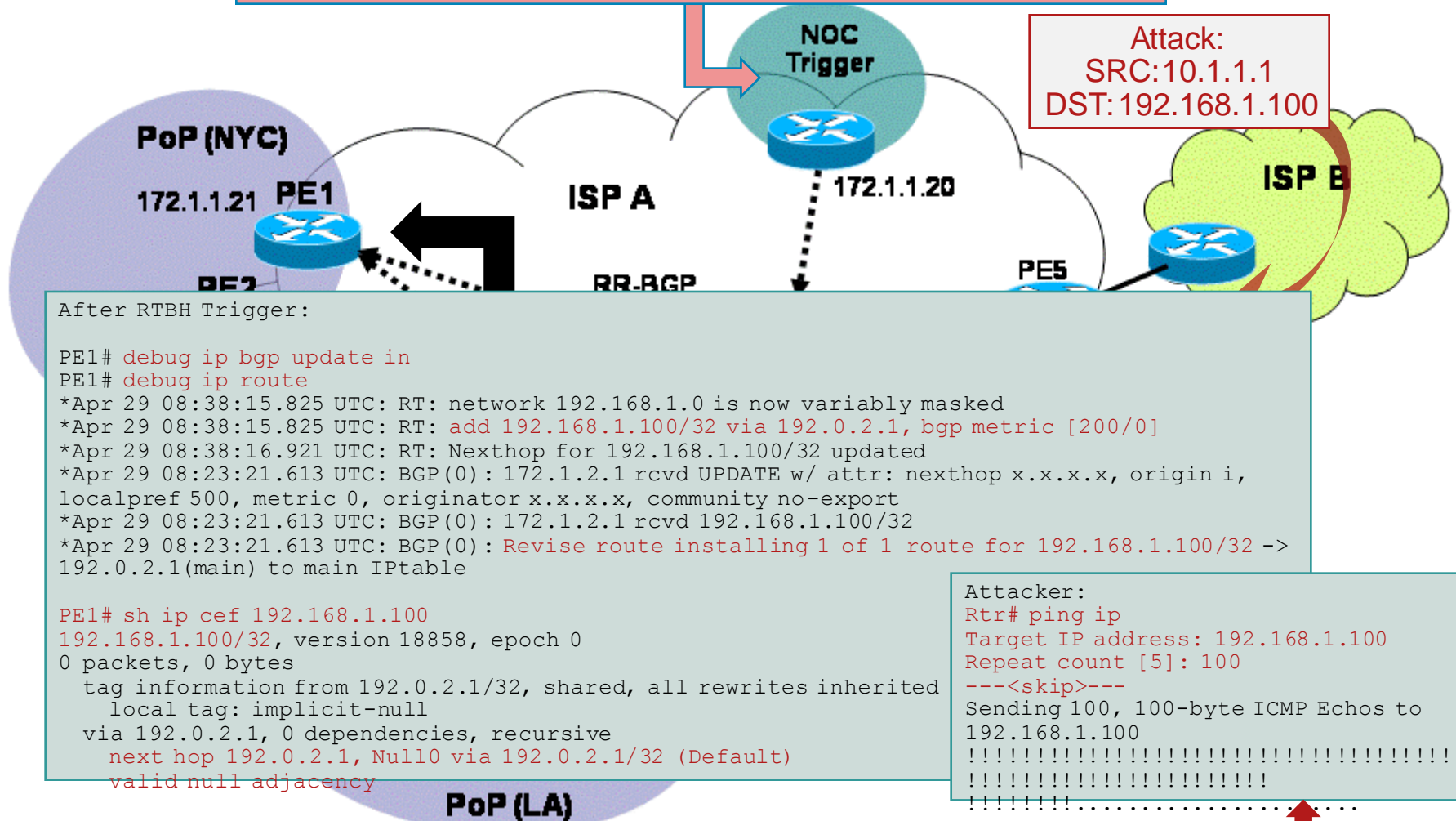

```
Attacker:
Rtr# ping ip
Target IP address: 192.168.1.100
Repeat count [5]: 100
---<skip>---
Sending 100, 100-byte ICMP Echos to
192.168.1.100
!!!!!!!!!!!!!!!!!!!!!!!!!!!!!!!!!!!!!!!!!!!!
!!!!!!!!!!!!!!!!!!!!!!!!!!!!!!!!!!!!!!!!!!!!
!!!!!!!!!!!!!!!!!!!!!!!!!!!!!!!!!!!!!!!!!!!!
!!!!!!!!!!!!!!!!!!!!!!!!!!!!!!!!!!!!!!!!!!!!
!!!!!!!!!!!!!!!!!!!!!!!!!!!!!!!!!!!!!!!!!!!!
```

Verification...



Filter, filter, filter ...

- Always filter all the BGP advertisements you send and receive
 - That includes your peers and customers
 - Filter all advertisements of DUSA (see RFC 3300)
- Positively, allow only allocated IPv4 blocks
 - Observe the minimum practical allocations for each block
- Be paranoid, your peers and customers will send you bad advertisements.

Stay informed



Welcome to the Human Network.

Reference: ISP Security Essentials

- The “bible” for Core Security
- Available as book, and on FTP:
<ftp://ftp-eng.cisco.com/cons/isp/security>
- How to secure the core
Security for devices, routing, traffic, management, ...

Stay informed

- NANOG
- RIPE
- Cymru:
 - Up to date information about SP core security, secure routing, bogon address ranges, etc... [www.cymru.com]
- nsp-security:
 - Closed list with the operations contacts of the big ISPs. Only for trusted contacts, very controlled.
[<https://puck.nether.net/mailman/listinfo/nsp-security>]
- nsp-security-discuss:
 - Closed list with the operations contacts of the big ISPs. Only for trusted contacts, a bit easier to access than nsp-security
[<https://puck.nether.net/mailman/listinfo/nsp-security-discuss>]

References



Welcome to the Human Network.

References

Product Security:

- Cisco's Product Vulnerabilities; A page that every SE MUST know!!!
[<http://www.cisco.com/warp/public/707/advisory.html>]
- Security Reference Information: Various white papers on DoS attacks and how to defeat them [<http://www.cisco.com/warp/public/707/ref.html>]

ISP Essentials:

- Technical tips for ISPs every ISP should know
[<ftp://ftp-eng.cisco.com/cons/isp/>]

Technical tips:

- Troubleshooting High CPU Utilization on Cisco Routers
[<http://www.cisco.com/warp/public/63/highcpu.html>]
- The “show processes” command
[http://www.cisco.com/warp/public/63/showproc_cpu.html]
- NetFlow Performance White Paper
[http://www.cisco.com/warp/public/cc/pd/iosw/prodlit/ntfo_wp.htm]

Mailing lists:

- cust-security-announce: All customers should be on this list.
- cust-security-discuss: For informal discussions.

Recommended Reading

Router Security Strategies: Securing IP Network Traffic Planes

Router Security Strategies: Securing IP Network Traffic Planes provides a comprehensive approach to understand and implement IP traffic plane separation and protection on IP routers. This book details the distinct traffic planes of IP networks and the advanced techniques necessary to operationally secure them. This includes the data, control, management, and services planes that provide the infrastructure for IP networking.

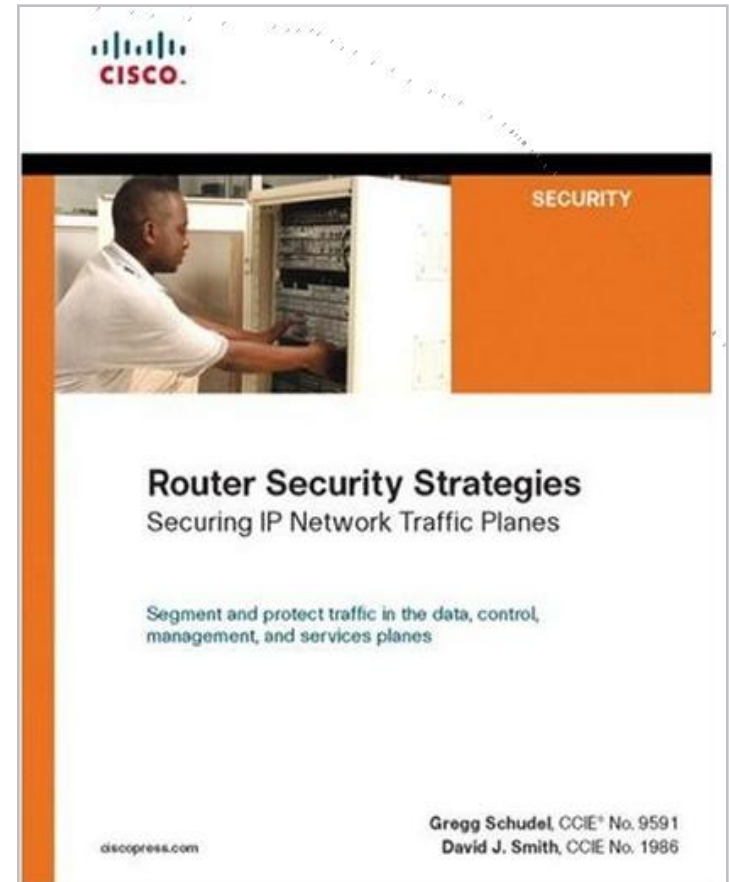

<http://www.ciscopress.com/bookstore/product.asp?isbn=1587053365>

Welcome to the Human Network.



CISCO