



# Leading The Mobile Transformation



**SAMAD NOUNI**  
**CONSULTING SYSTEMS ENGINEER**  
**[snouni@cisco.com](mailto:snouni@cisco.com)**

# Agenda

- 3GPP Release Overview
- Architectural requirements from 2G/3G and LTE
- Mobile Backhauling Options and Functions
  - Role of MPLS and Pseudowire
  - Traditional 2G/3G backhauling
  - Native IP Support on Node B/RNCs
  - Synchronisation capabilities
- LTE/SAE Architectural Considerations
- Evolution towards a Converged IP NGN Architecture



# 3GPP Release Overview



# In the beginning was GSM....

- There was wireless ISDN (aka GSM)

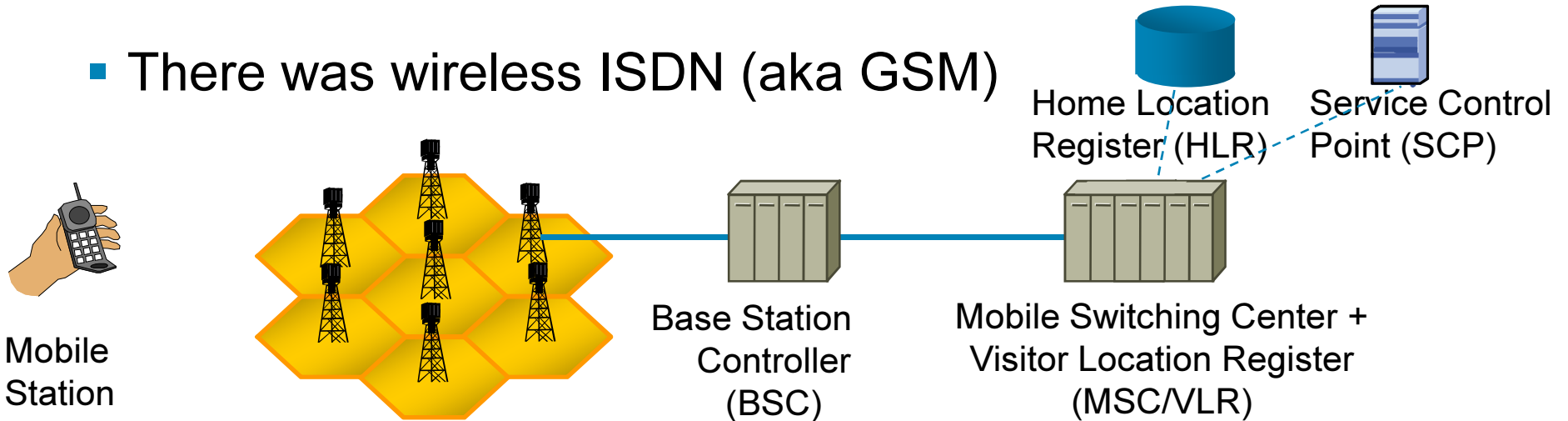

Connection Management
Mobility Management
Radio Resource Management
LAP-Dm
GSM Radio

Base Transceiver System (BTS)

- Voice oriented architecture
- Re-define fixed wireline services
- SMS is a signalling transport rather than a data service
- Network transport based on TDM

RR'	BTSM
LAP-Dm	LAP-D
GSM Radio	16/64 kbps

RR'	BSSAP
LAP-D	SCCP MTP/b
16/64 kbps	64/2048 kbps

Connection Management	BSSMAP	TUP	ISUP	INAP	MAP
Mobility Management					
DTAP	BSSAP				TCAP
SCCP					SCCP
MTP/MTPb		MTP			
64/2048 kbps		64 kbps			

# Packet data with General Packet Radio System was bolted on.....

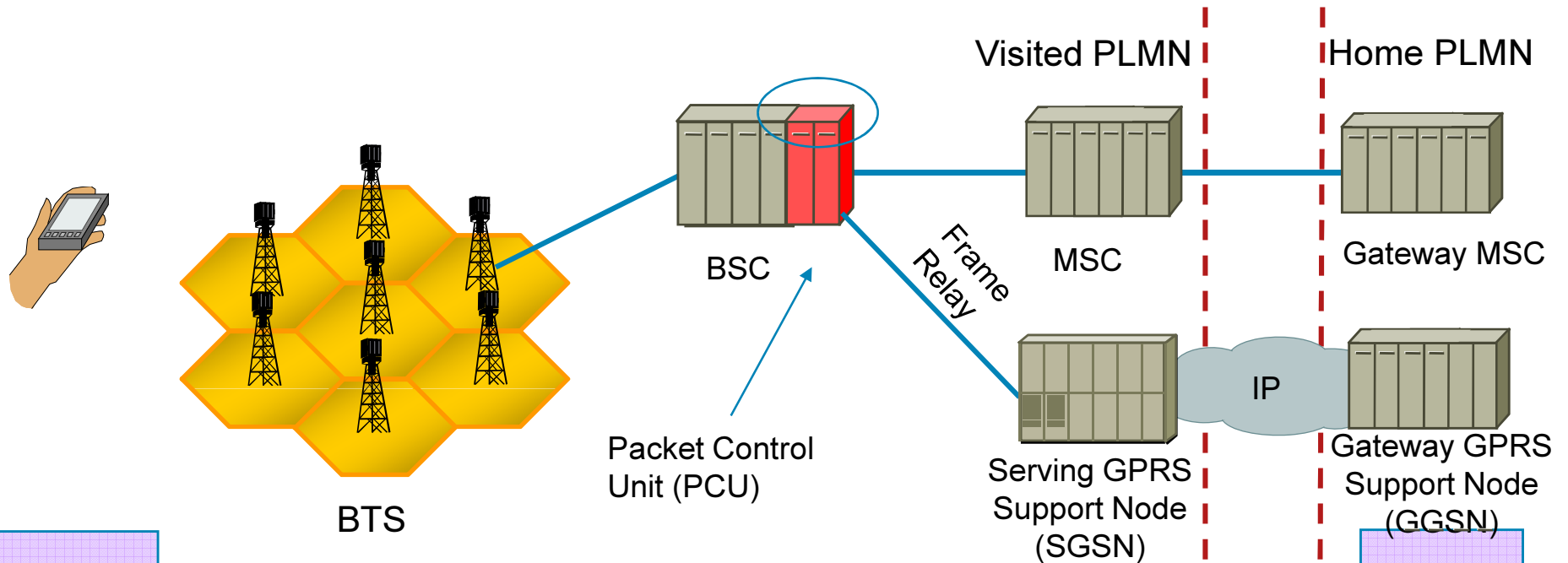

IP
SNDCP
LLC
RLC
MAC
GSM Radio

Relay	
GSM Radio	64 kbps

Relay	
RLC	BSSGP
MAC	Network Services
64 kbps	L1bis

Relay	
SNDCP	GTP
LLC	UDP
BSSGP	IP
Network Services	L2
L1bis	L1

IP
GTP
UDP
IP
L2
L1

# 3G Packet Services

- So hopefully WCDMA got it right on packet services...

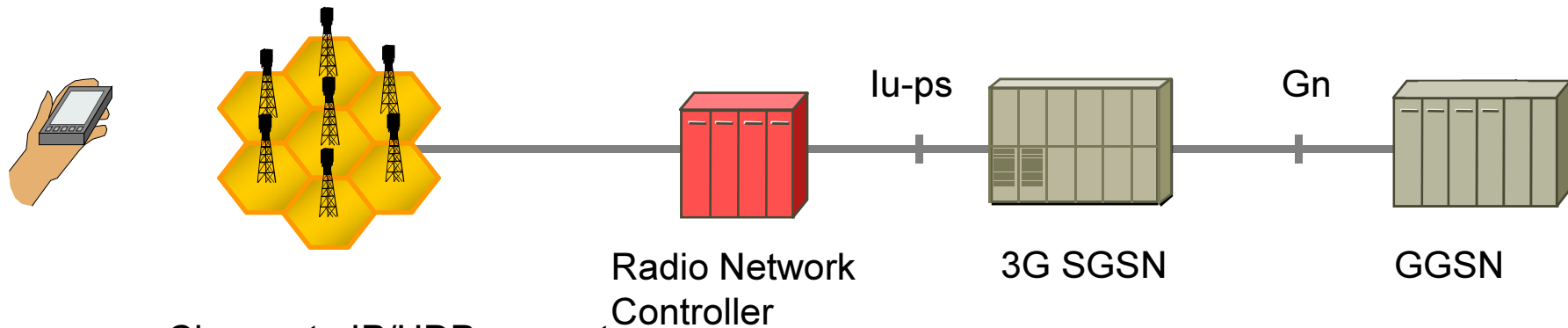

Change to IP/UDP support for Ethernet enabled NodeBs

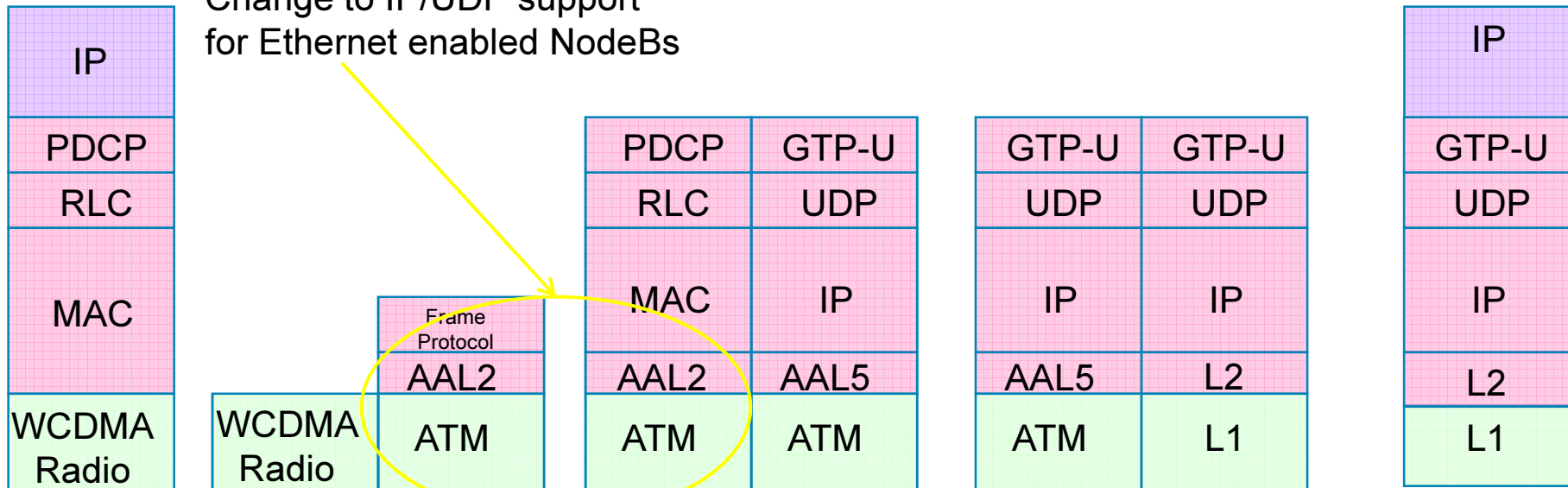

# 3GPP R4 Voice Services

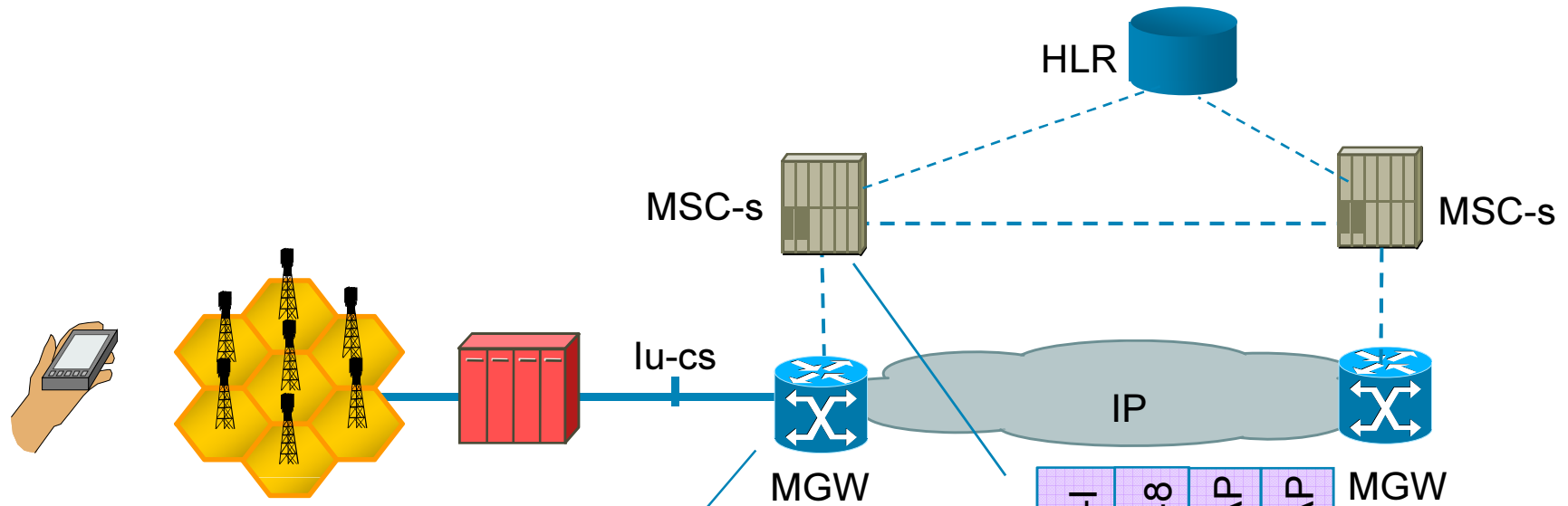

- Still Voice over Circuit Switched bearer on the radio access, data bearer not suitable (latency, overhead)
- Option to transport Voice over IP in the Core (see TS 23.205)
- Introduction of SS7 to IP transport

	Nb UP
Uu	RTP
Iu-UP	UDP
AAL2	IP
ATM	L1/2

BICC or SIP-I	H.248	INAP	MAP
		TCAP	
		SCCP	
		M3UA	
	SCTP		
	IP		
	L1/2		

# High Speed Packet Access

... About Mobile Broadband Access

- Although touted to support 2 Mbit/s services, R99 typically supported a maximum throughput of 384 kbit/s
- Subsequent releases (3GPP R5 and onwards) focusing on increasing bandwidth and network efficiency for the mobile data access
  - R5: HSDPA (improved DL)
  - R6: HSUPA (improved UL)
  - R7: Direct Tunnel Approach
- Session establishment and Latency improvements
- HSPA is required to support symmetrical real-time data applications (e.g. multimedia over IP)

# LTE/SAE 3GPP Release 8

- A new radio (Long Term Evolution) and core network (System Architecture Evolution) **all-IP network**
- Long Term Evolution is a **evolution** in the air interface from WCDMA to OFDMA
- System Architecture Evolution is the new core network supporting the new LTE radio, **plus legacy, plus non-3GPP networks**

# LTE/SAE System Components

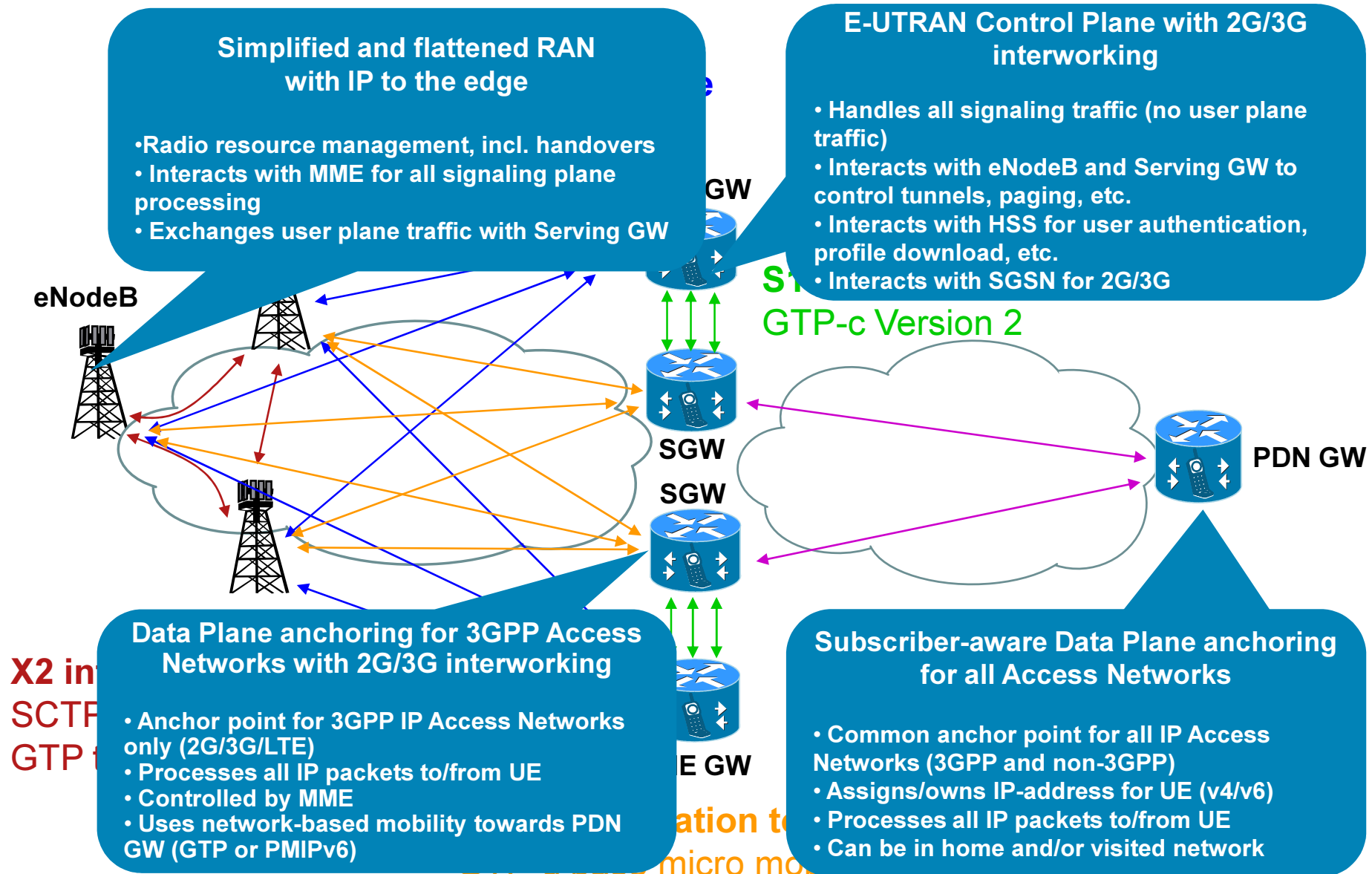

**Simplified and flattened RAN with IP to the edge**

- Radio resource management, incl. handovers
- Interacts with MME for all signaling plane processing
- Exchanges user plane traffic with Serving GW

**E-UTRAN Control Plane with 2G/3G interworking**

- Handles all signaling traffic (no user plane traffic)
- Interacts with eNodeB and Serving GW to control tunnels, paging, etc.
- Interacts with HSS for user authentication, profile download, etc.
- Interacts with SGSN for 2G/3G

Serving GW  
GTP-c Version 2

**Data Plane anchoring for 3GPP Access Networks with 2G/3G interworking**

- Anchor point for 3GPP IP Access Networks only (2G/3G/LTE)
- Processes all IP packets to/from UE
- Controlled by MME
- Uses network-based mobility towards PDN GW (GTP or PMIPv6)

**Subscriber-aware Data Plane anchoring for all Access Networks**

- Common anchor point for all IP Access Networks (3GPP and non-3GPP)
- Assigns/owns IP-address for UE (v4/v6)
- Processes all IP packets to/from UE
- Can be in home and/or visited network

X2 in  
SCTP  
GTP

ation to  
micro mo



# Architectural requirements from 2G/3G to LTE



# In Europe Mobile Broadband is a reality

**No.1 objective** is to increase bandwidth while **reducing** cost

LTE:  
100 Mbit/s DL  
50 Mbit/s UL

An Operator in Nordics where traffic is **Doubling every 3 months**

5.8 Mbit/s UL

**Ethernet Microwave & IP NodeBs** is a key initiative in 2008-2009

A **European SP** calculate average LTE backhaul will be 40 Mbps

GPRS: 160

2002

SPs are transforming into vertically integrated **multimedia SPs**<sup>1</sup>

3xE1

5xE1

8xE1

??xE1

<sup>1</sup>Infonetics – November 2009

# 2G & 3G Traditional Network

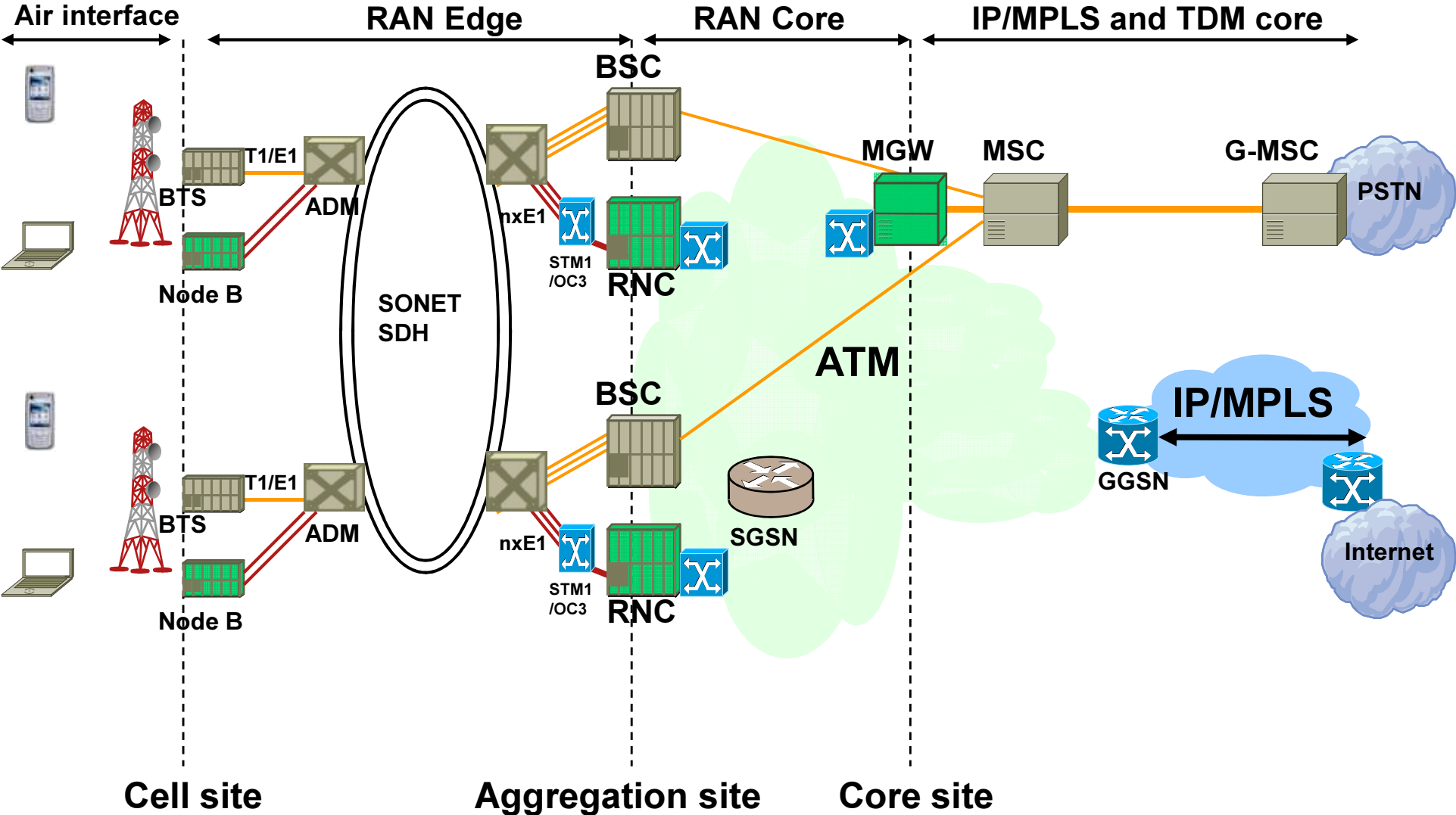

# 3G R4 IP/ATM Converged IP backbone

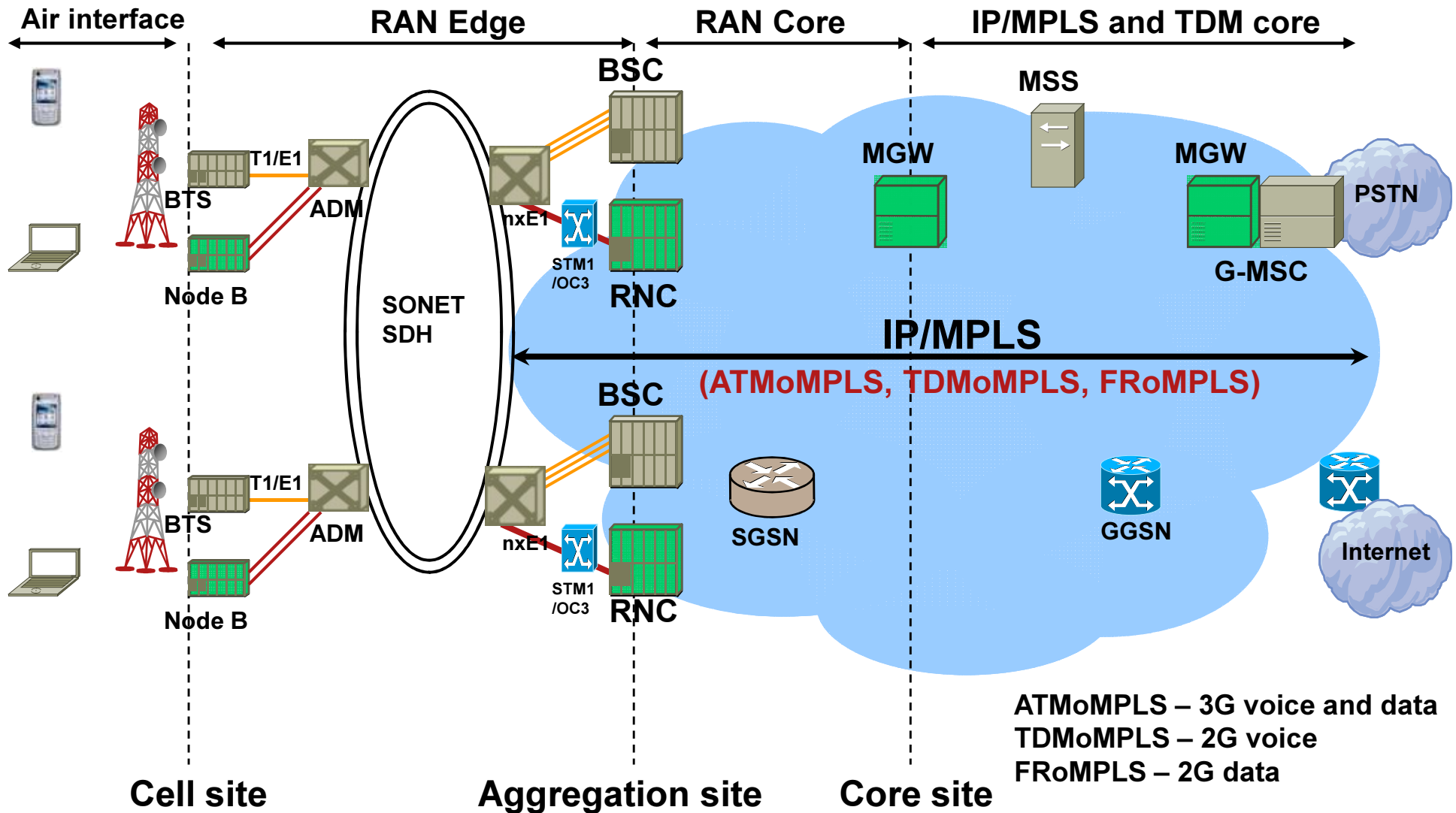

# Emulation/IP Technologies to Cell Site

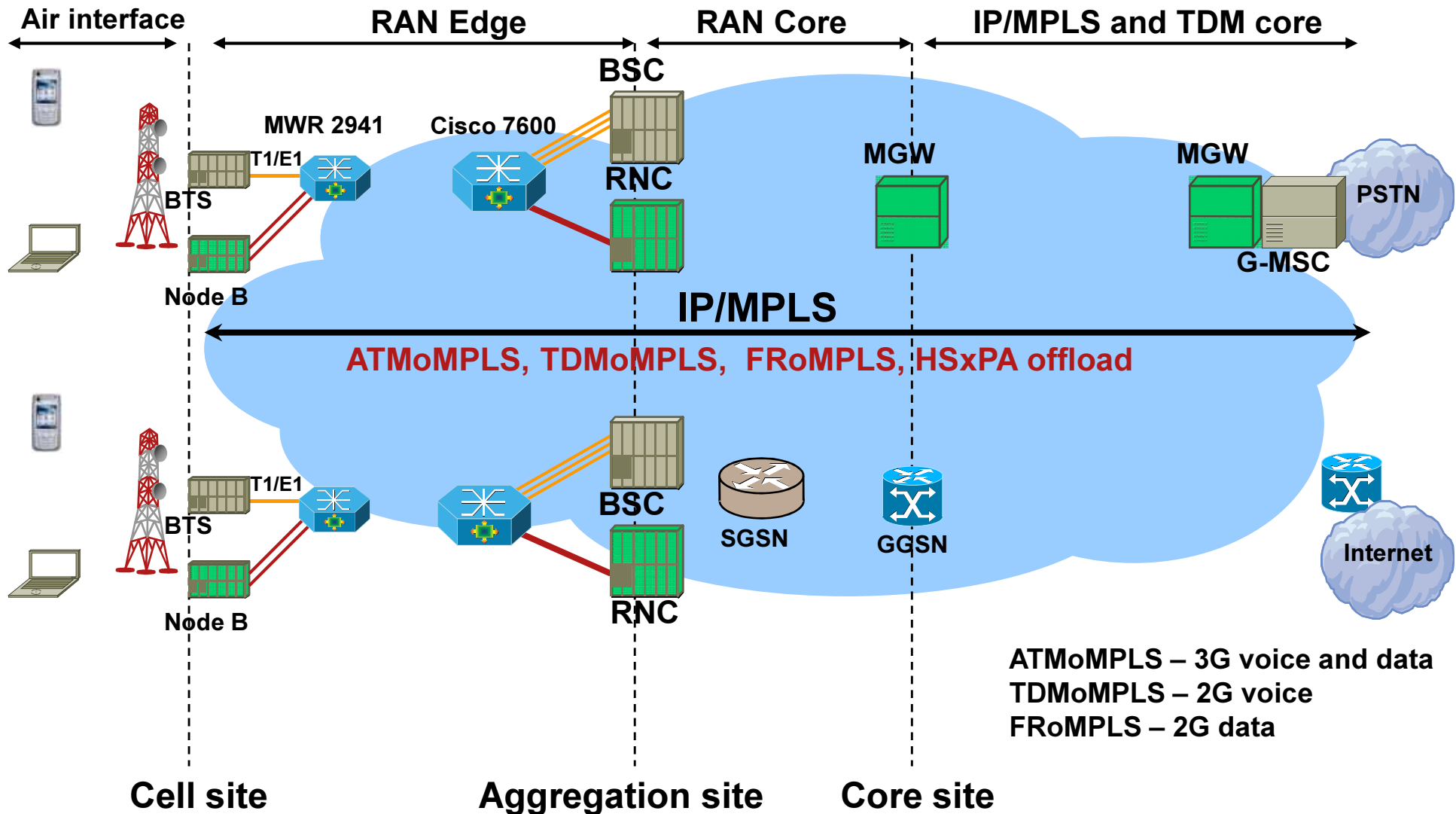

# LTE/Mobile and Wireline Infrastructure

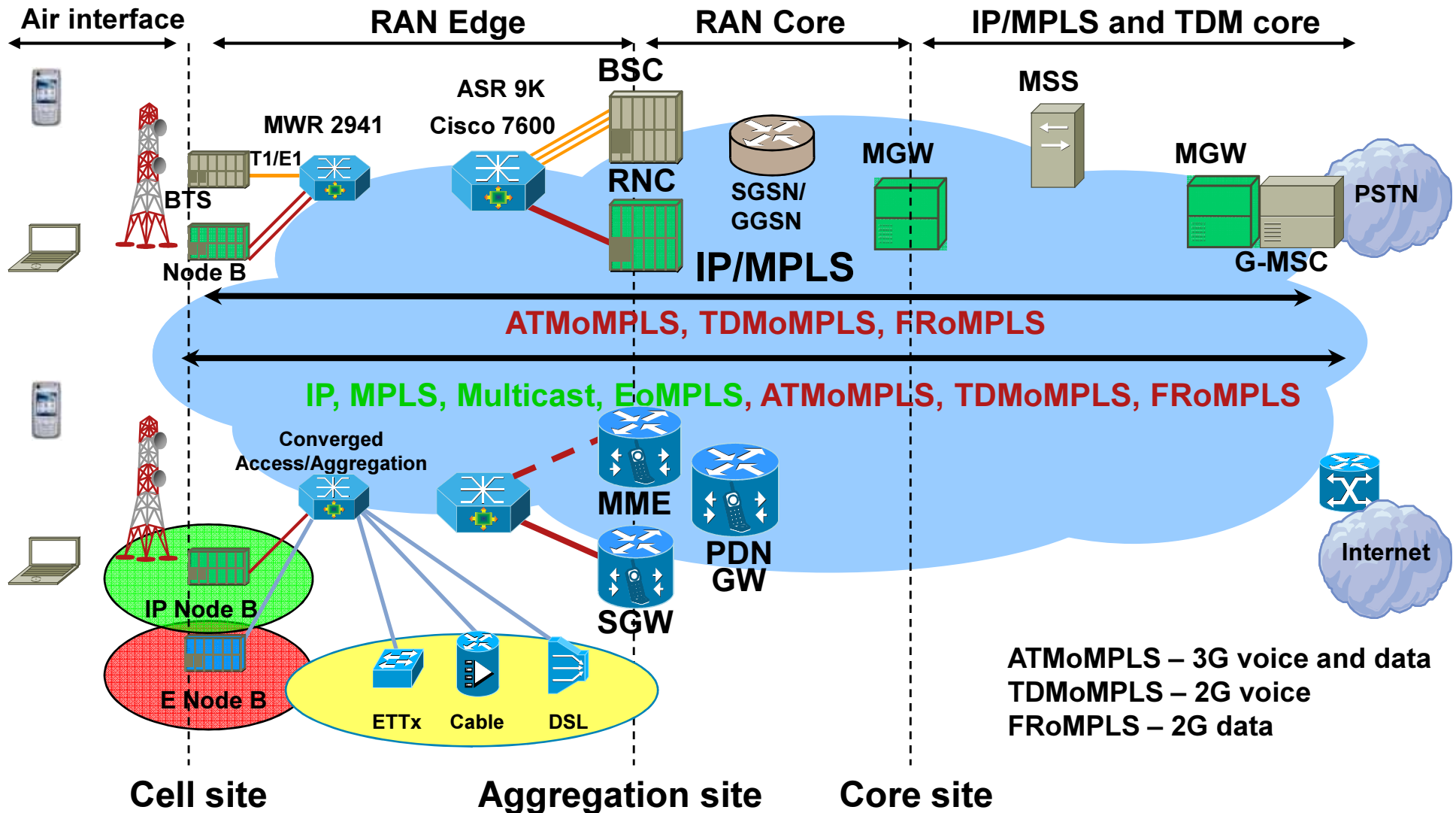

# Collapsed Transport Layers

Yesterday\Today

Evolution  
Not revolution

Tomorrow

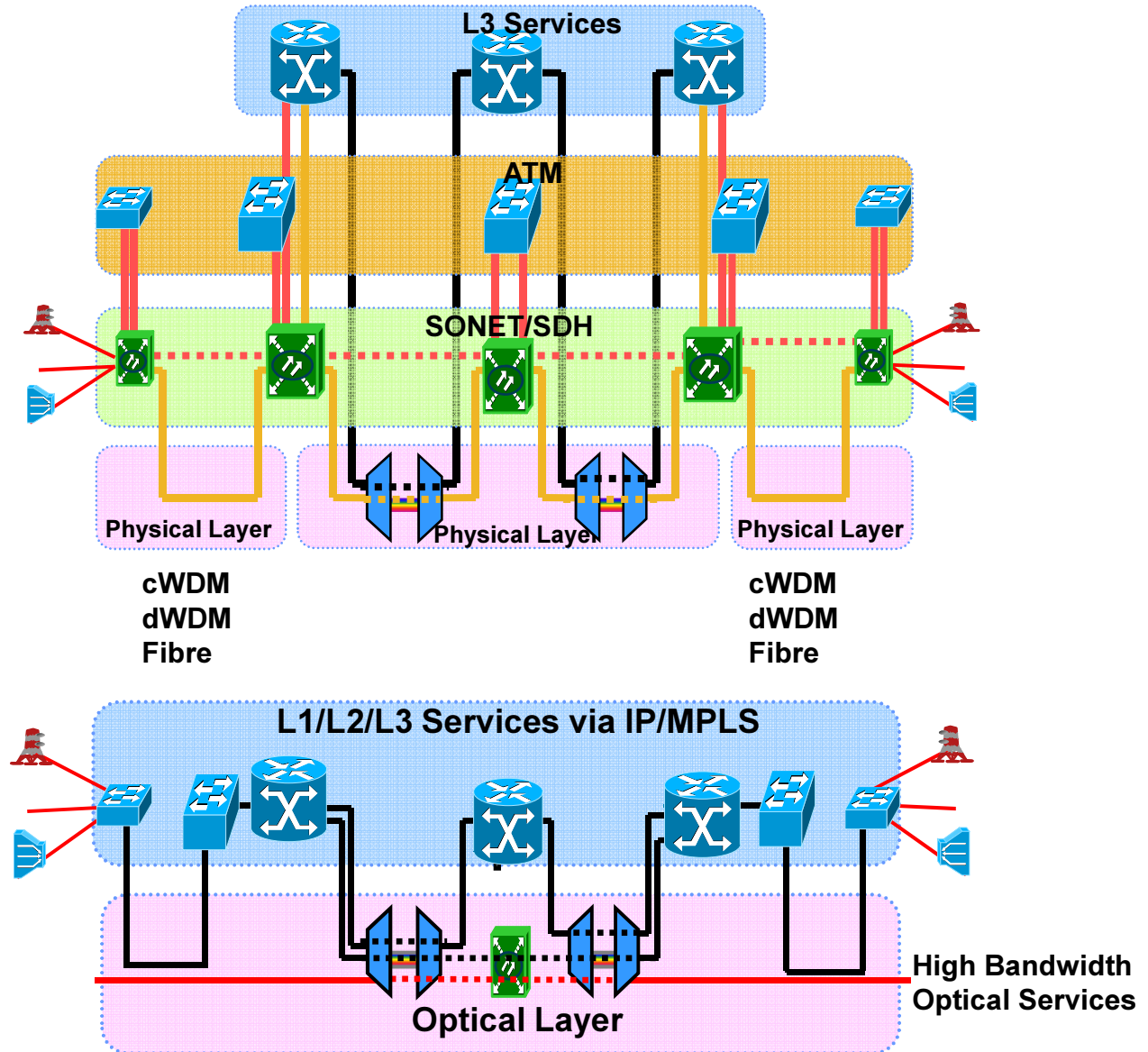



# Mobile Backhauling Options and Functions





# Role of MPLS PseudoWire PWE3



## What is a Pseudowire (PWE3)?

“It is a Point-to-Point logical ‘wire’ that enables the ability to pass legacy traffic (TDM and ATM) over an existing packet core.”

- *Luca Martini (PWE3 Concept Inventor)* -



Luca Martini  
Cisco Dist Eng    SP Systems and Arch

# Role of MPLS and Pseudowire

- **Bringing SONET/SDH SLAs to Carrier Ethernet**

Resiliency Advantages: Cisco End-to-End

Fast Convergence (< 50ms recovery)

High Availability

Redundancy

QoS

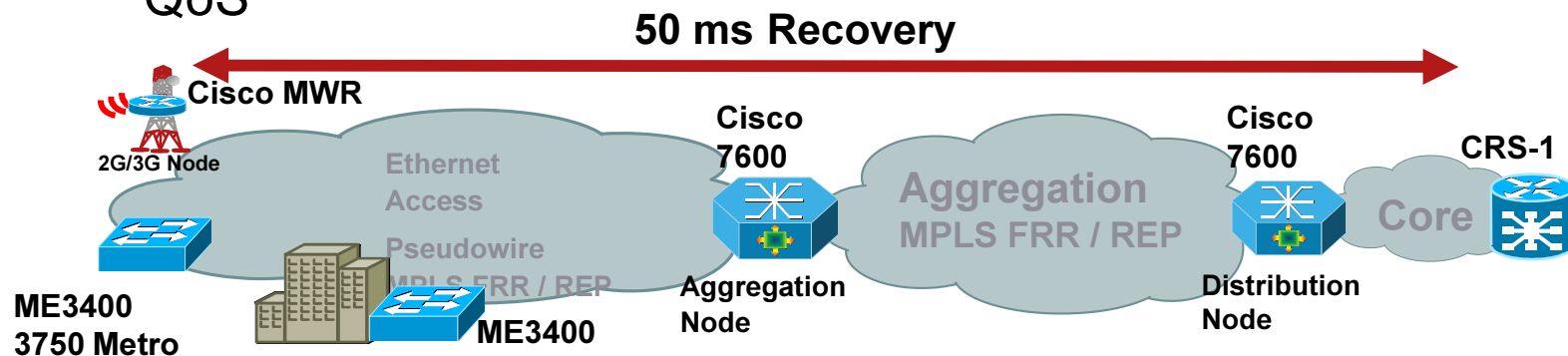

# Role of MPLS Pseudowire

- **Ethernet pseudowire**

Ethernet link to L3 VPN, Ethernet LAN ( VPLS ), Ethernet Line (EoMPLS )

- **ATM pseudowire**

Used for 3G only

Inefficient for a single cell but only sends traffic when required

Use of cell packing can reduce overhead with minimal impact on latency

- **TDM pseudowire**

Used for 2G and 3G

Just as a real TDM circuit, bandwidth is wasted when the circuit is not being fully utilized.

# Legacy network support

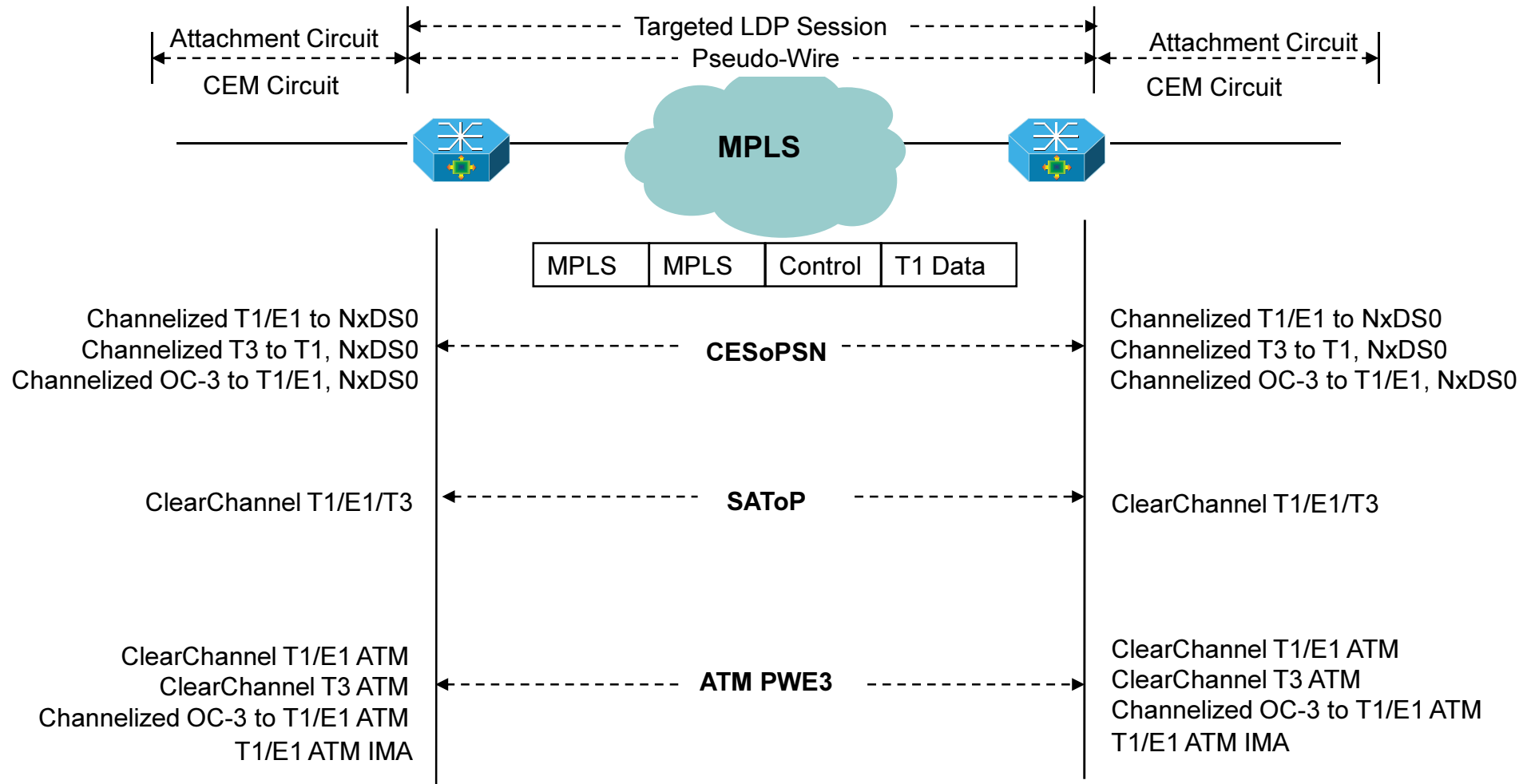

SAToP : Structured Agnostic TDM over Packet : draft-ietf-pwe3-satop-05.txt , RFC-4553

CESoP : Circuit Emulation Service over Packet : draft-ietf-pwe3-cesopsn-06.txt

IMA : Inverse Multiplex over ATM



# Traditional 2G/3G Backhauling



# Legacy ATM and TDM Transport

Converged Packet Network with L2 in access/Pre-Agg.

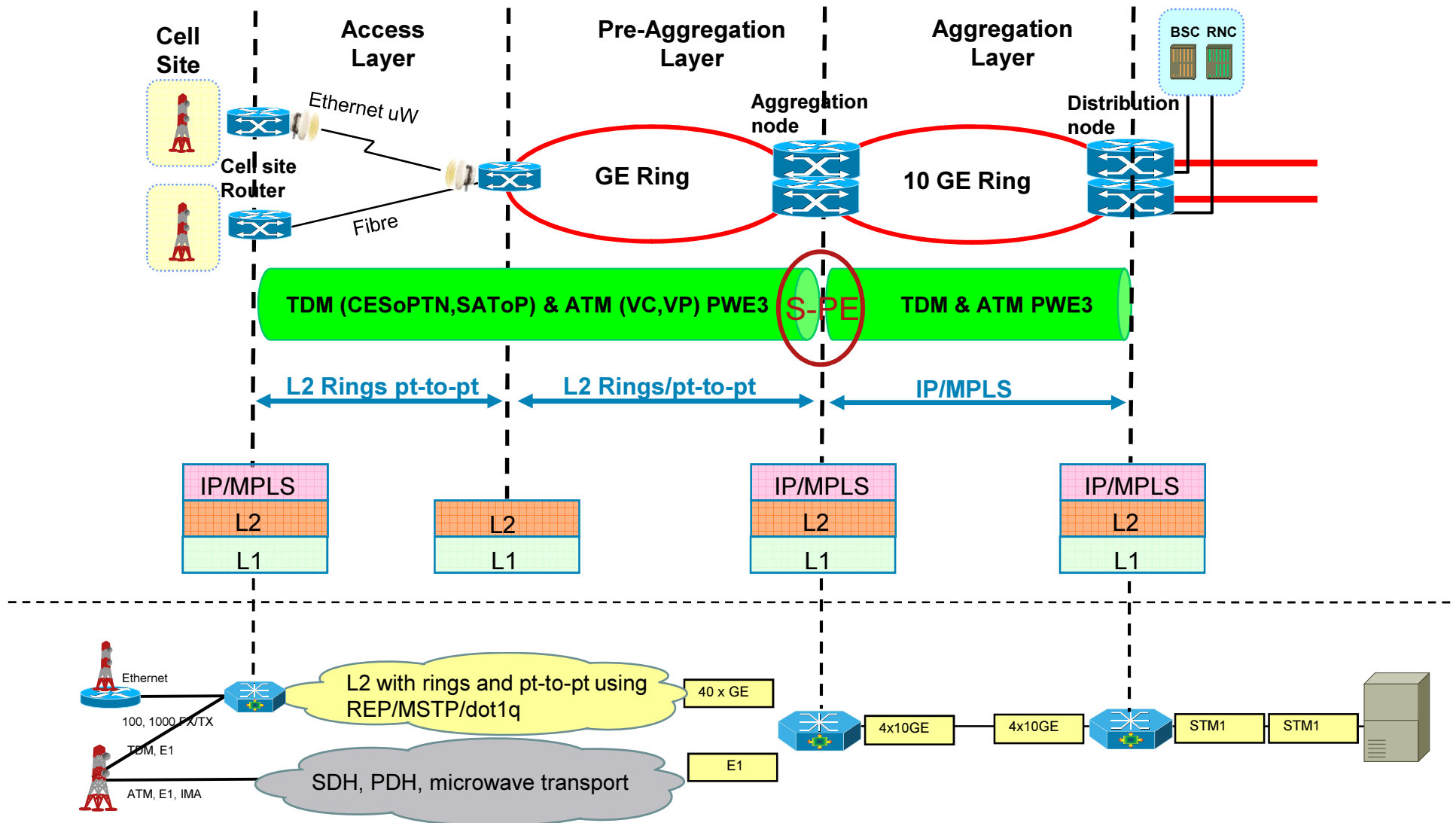

# Legacy ATM and TDM Transport

Converged Packet Network with L3 in access/Pre-Agg.

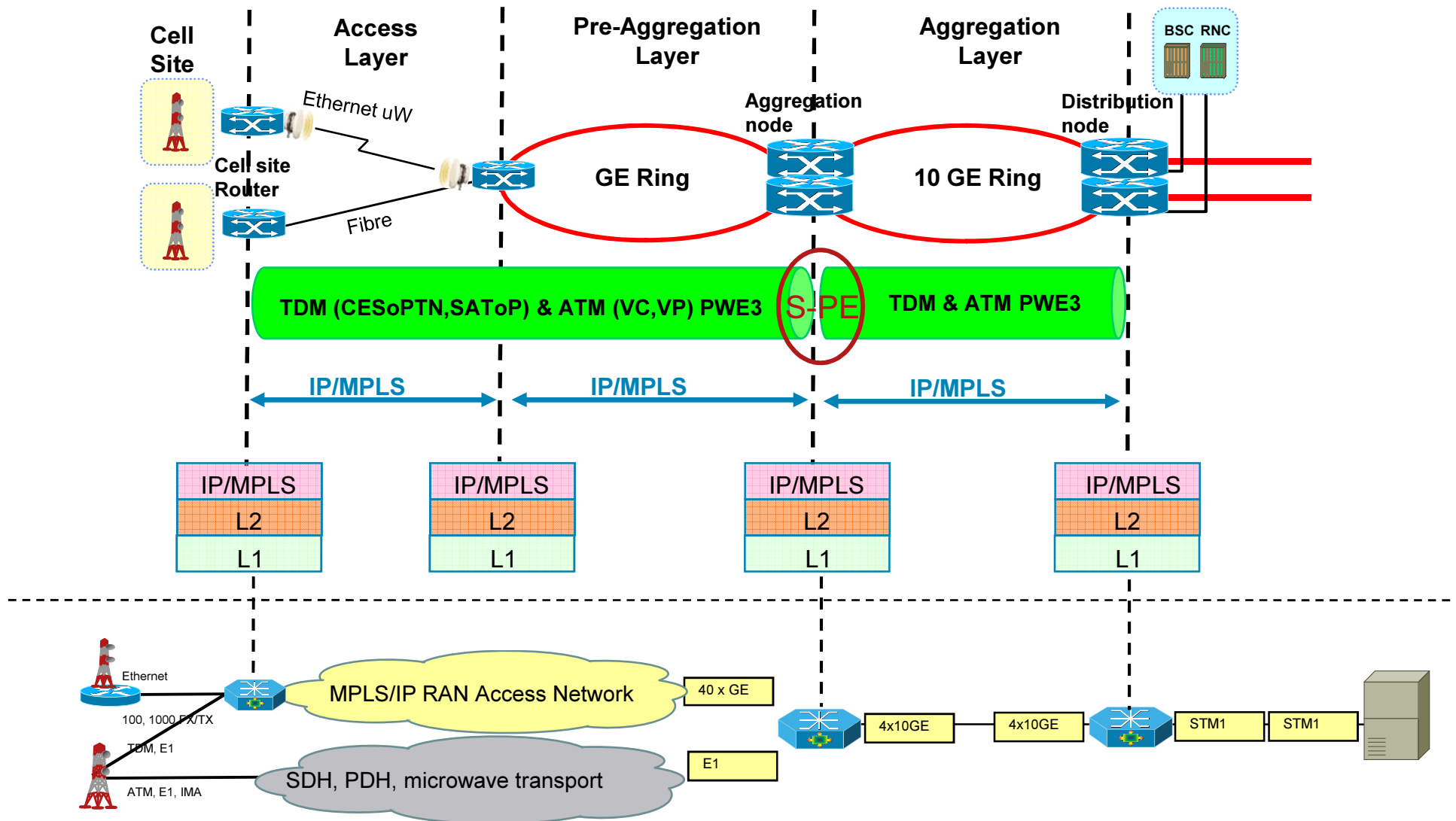

# MToP (Mobile Transport Over Packet)

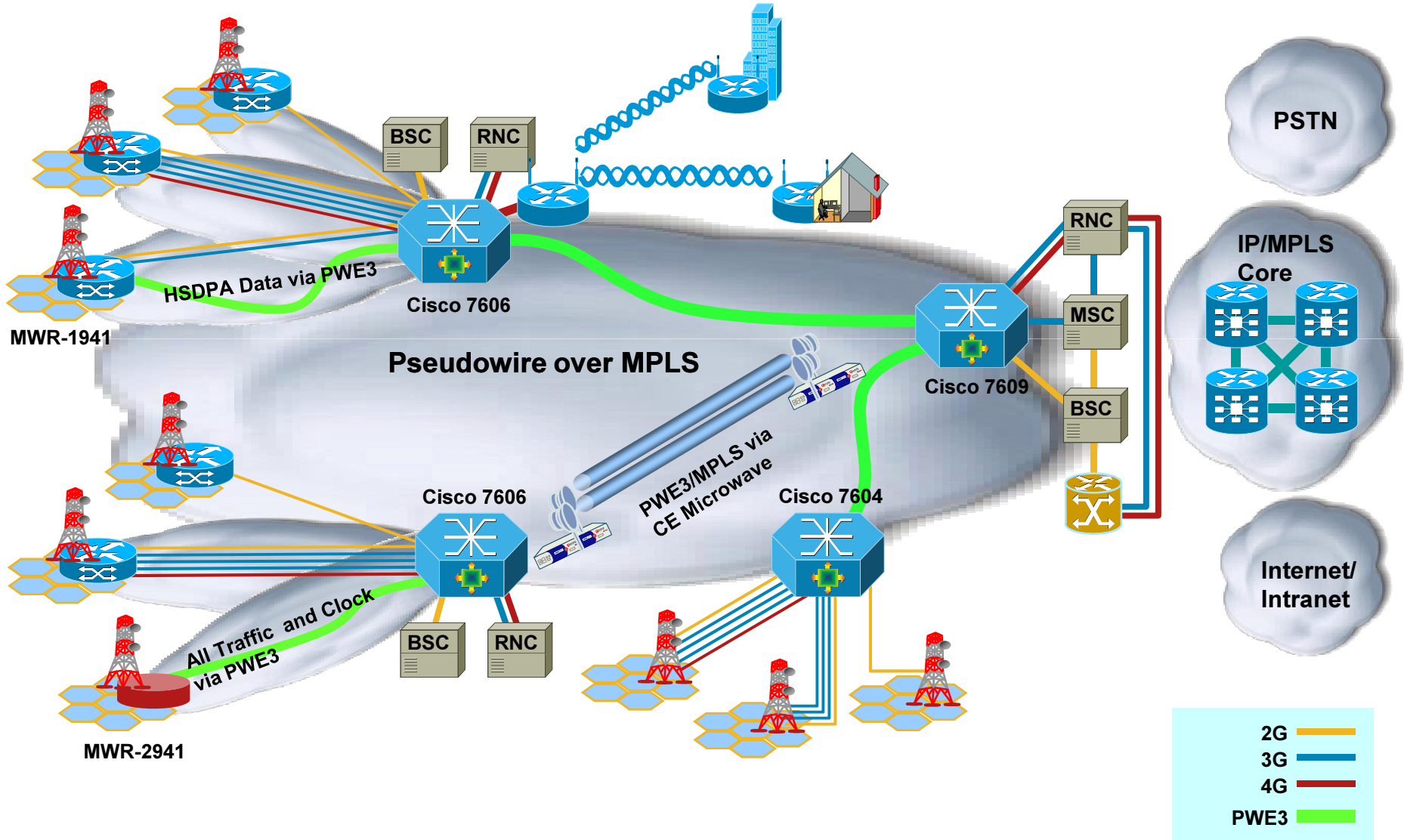

# CEoP (Circuit Emulation Over Packet)

## ▪ Standards based Offering

Compliant to G.823/G.824 traffic interface (T1/E1 and T3/E3)

Meets Mobile Wireless 3GPP requirements (clock accuracy better than 15ppb)

IETF draft-ietf-pwe3-cesopsn-xx.txt: Structure-aware TDM Circuit Emulation Service over Packet Switched Network (CESoPSN)

RFC 4553: Structure-Agnostic TDM over Packet (SAToP)

ITU: Y.1413 TDM-MPLS Network Interworking

## ▪ Key Features

BITS Clocking Support

Unstructured -- Emulate full DS1, E1, DS3 or E3 services

Structured -- Emulate Nx64kbit/s services

Configurable jitter buffer 1-500ms (+/- 250 ms )

## ▪ Support for ATM (Including IMA)

24-port Channelized T1/E1

1 Port Channelized OC3/STM1 down to T1/E1,

2 port Channelized T3/E3 down to T1/E1



4 SPAs per SIP-400

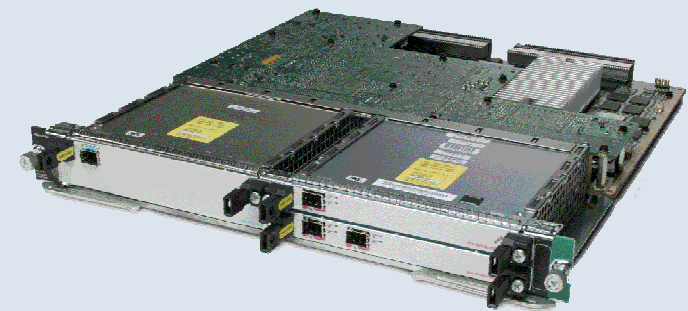

CISCO 7600 SIP-400

# Cisco MWR 2941-DC



***Most Compact, Affordable  
High Performance  
Cell Site Router with  
Features Enabled***

- **Cisco's Latest MWR Series Product**
- **Six Built-In GE Ports (4 RJ-45, 2 SFP)**
- **16 Built-In T1/E1 Ports**
- **Multiple Industry Standard Clocking Options**  
IEEE 1588v2, Sync-E, Adaptive, Stratum 3
- **Expanded Capacity**  
Support for 2800/3800 HWICs i.e. xDSL
- **Key Applications**
  - IP RAN:** Activate flexible and efficient all-IP RANs for new revenue-generating services with intelligent IP network features
  - Standards Based Pseudowire:** Use IETF PWE3 to transport 2G, 3G and 4G wireless networks over low-cost alternative networks such as xDSL, Carrier Ethernet, MPLS, etc.



# Native IP Support on Node B/RNCs



# Ethernet IP NodeB Transport

## Converged Packet Network with L2/L2VPN

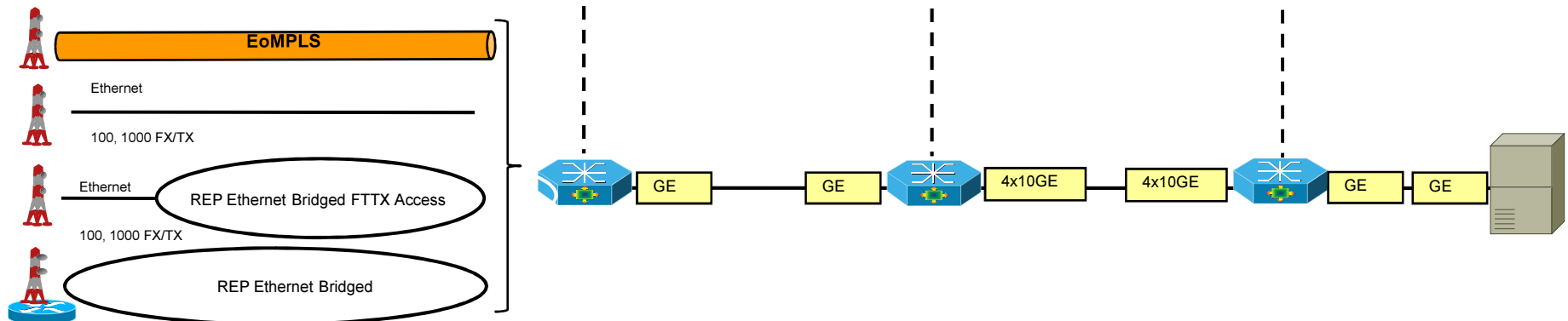
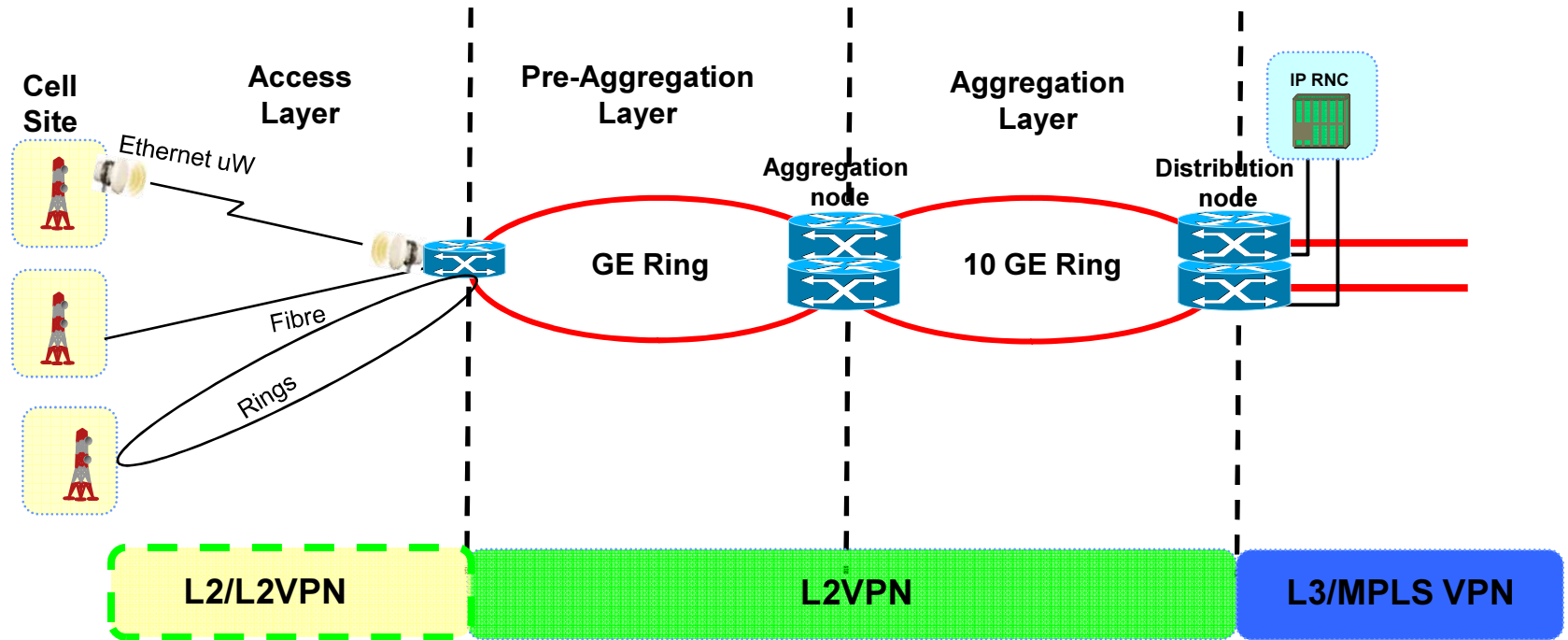

# Ethernet IP NodeB Transport

## Converged Packet Network with Distributed L3 Edge

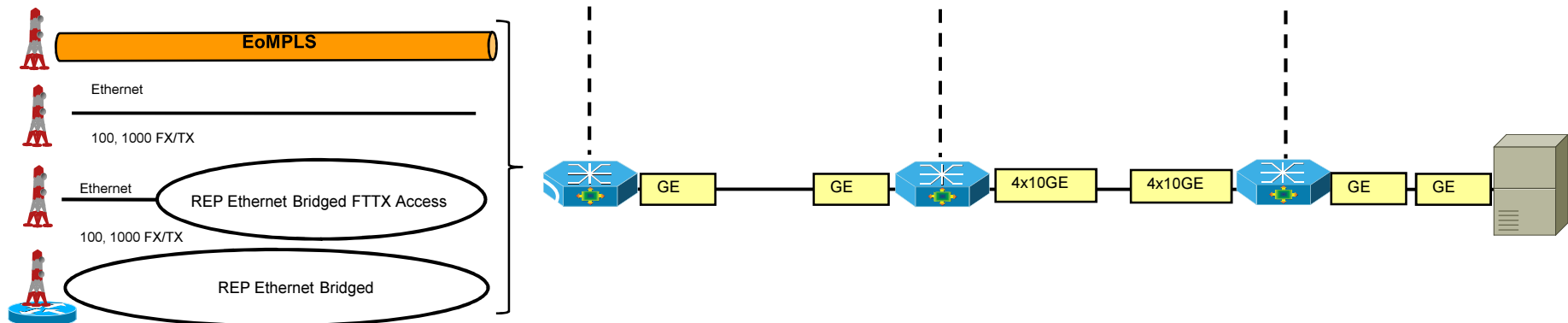
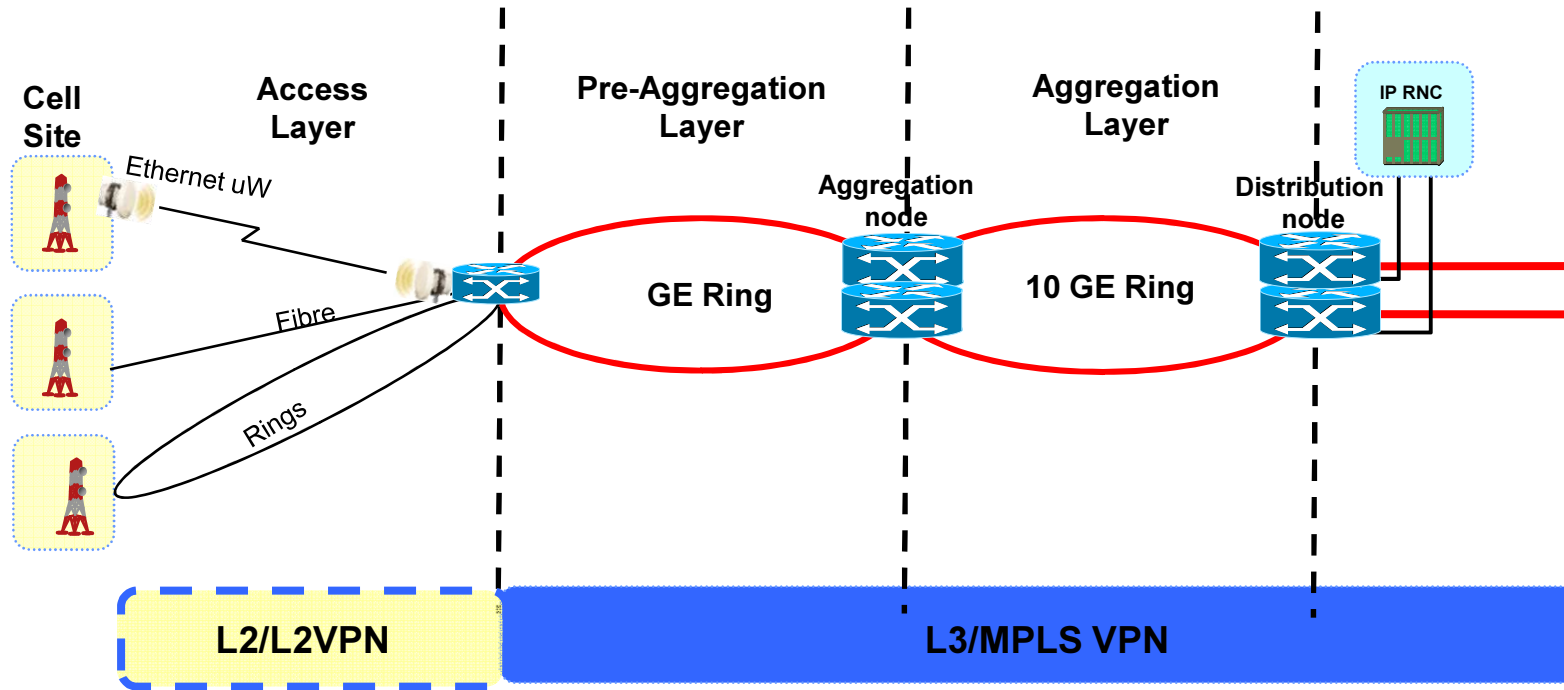



# Synchronisation capabilities



# Network Clock Synchronization Options



## Synchronize the clock between the disjoint TDM Links

1. **Synchronous** : Cell site router receives the same TDM clock from an external source, like, BITS, SONET, GPS, etc.
2. **Adaptive** : Routers do NOT have common clock source. Instead, the clock is derived based on packet arrival rates.
3. **Differential** : Both Cell site and Aggregation routers have the same clock source. In addition, the TDM clocks are derived from differential information in RTP header of the packet with respect to the common clock.

# Frequency and Phase Introduction

Frequency= Stability

Phase=Precision

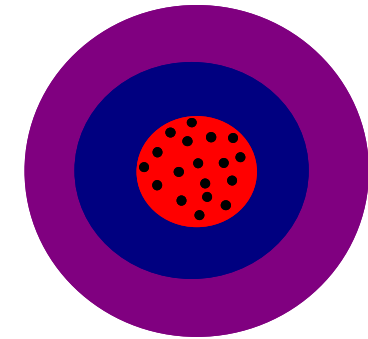
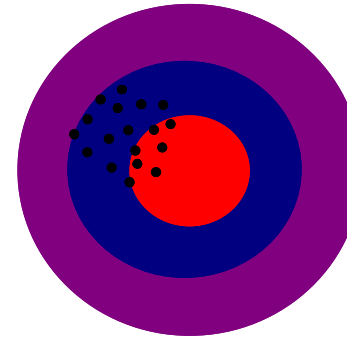
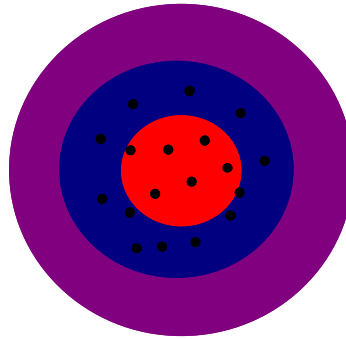
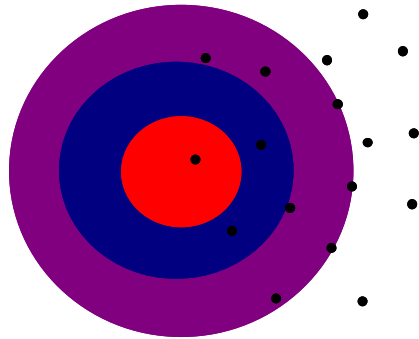

Not Stable  
Not Accurate

Not Stable  
Accurate

Stable  
Not Accurate

Stable  
Precise

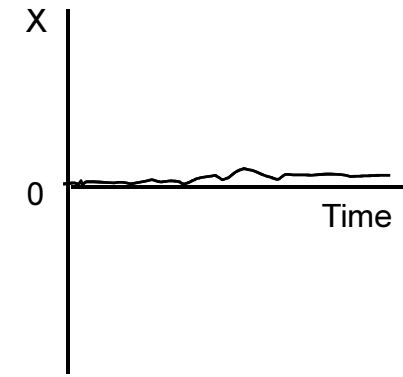
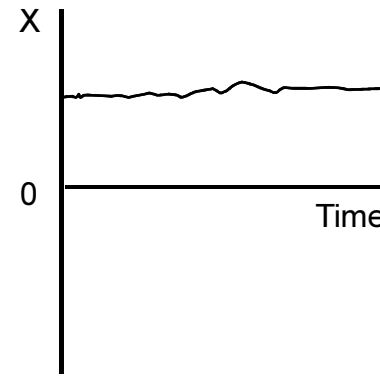
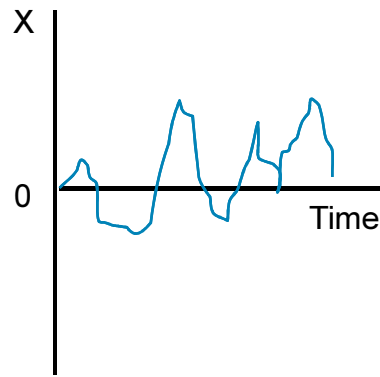
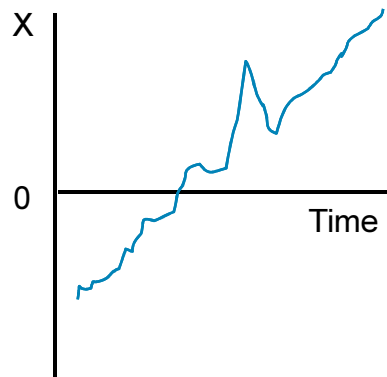

Not Stable and  
Not Accurate

Not Stable  
but Accurate

Stable but  
Not Accurate

Stable  
And Accurate

# Ethernet Clocking Mechanism Comparisons

	<b>Advantages</b>	<b>Disadvantages</b>
GPS	Reliable PRC Relatively cheap Frequency and phase	Antenna required US Govt owned
PRC/BITS	Reliable PRC Generally Available	No Phase Need to maintain TDM in all Ethernet deployment
1588-2008	Packet Based (Frequency and Phase)	Requires Master w/ PRC Performance influenced by network Undefined Profiles in SP environments
SyncE/ESMC	Physical layer (Frequency)	No Phase Every node in chain needs to support
NTPv4	Packet Based (Frequency and Phase)	Not as robust as 1588-2008 Open standard Some proprietary implementations

# Synchronisation Requirement

Application Requirements for Frequency & Time/Phase

Synchronisation Service	Application
Frequency	TDM (CES/CEoPS)
	SDH transform to PSN
	GSM
	3G FDD
	LTE-FDD
	DVB-T/-H
Time (Phase)	LTE TDD
	LTE MBSFN
	DVB-T/-H SFN
	Mobile Wimax

# Clock Recovery with Out-of-band Pseudowires

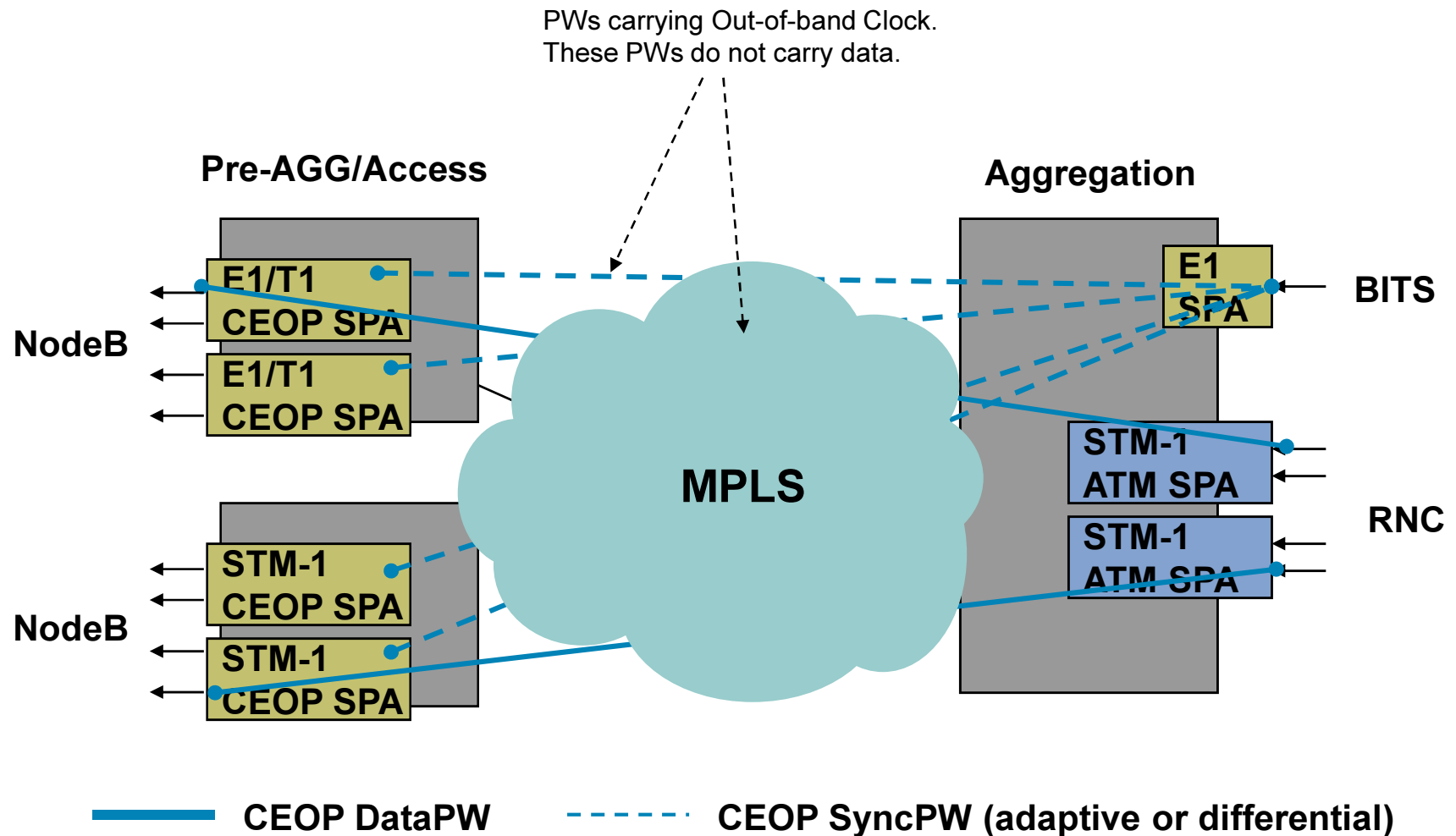

# European Customer Network Topology

BTI GMC with BTI Client

**Cellsite**

**Central Office**

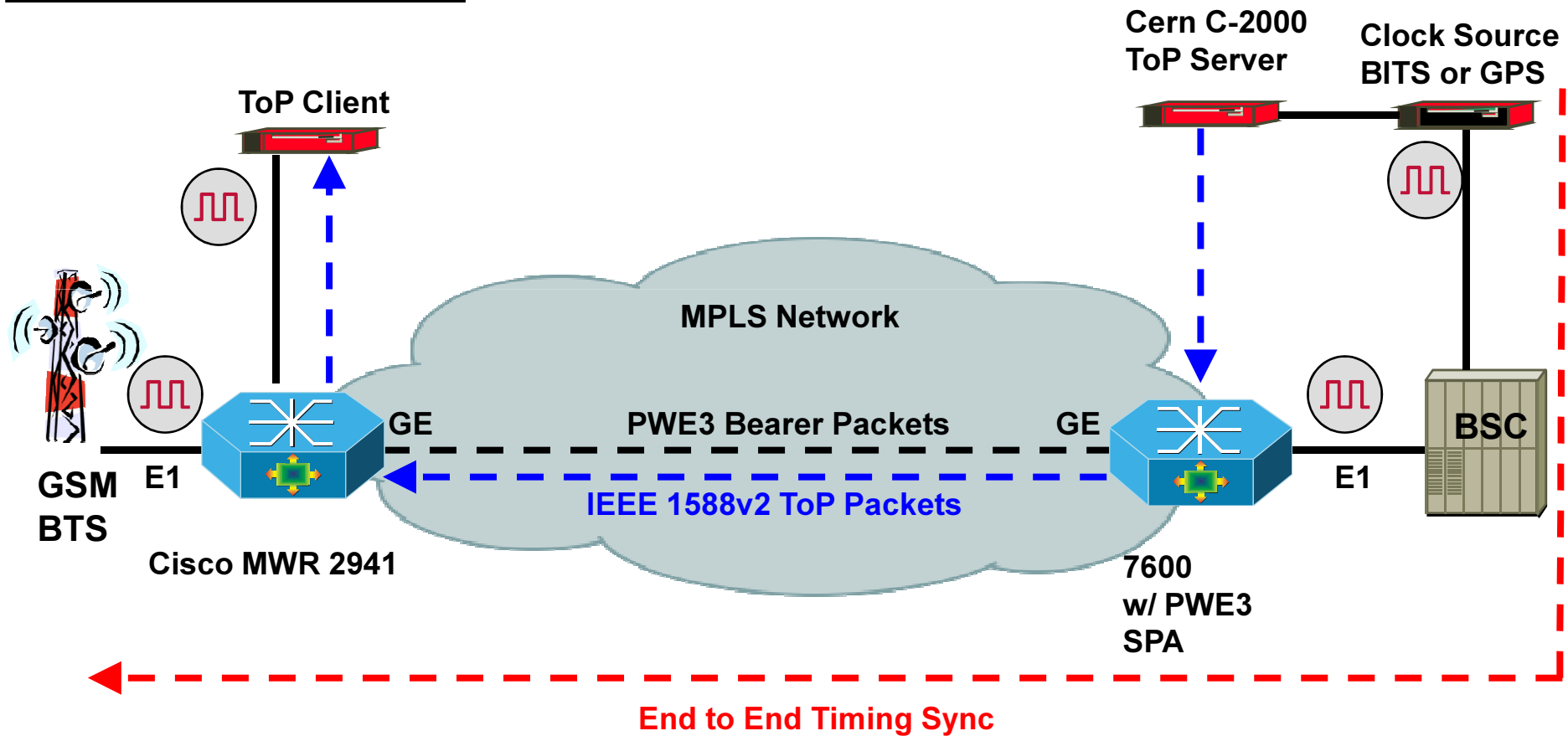



# LTE/SAE Architectural Considerations



# X2 Interface and Handover

X2 interface function during handover

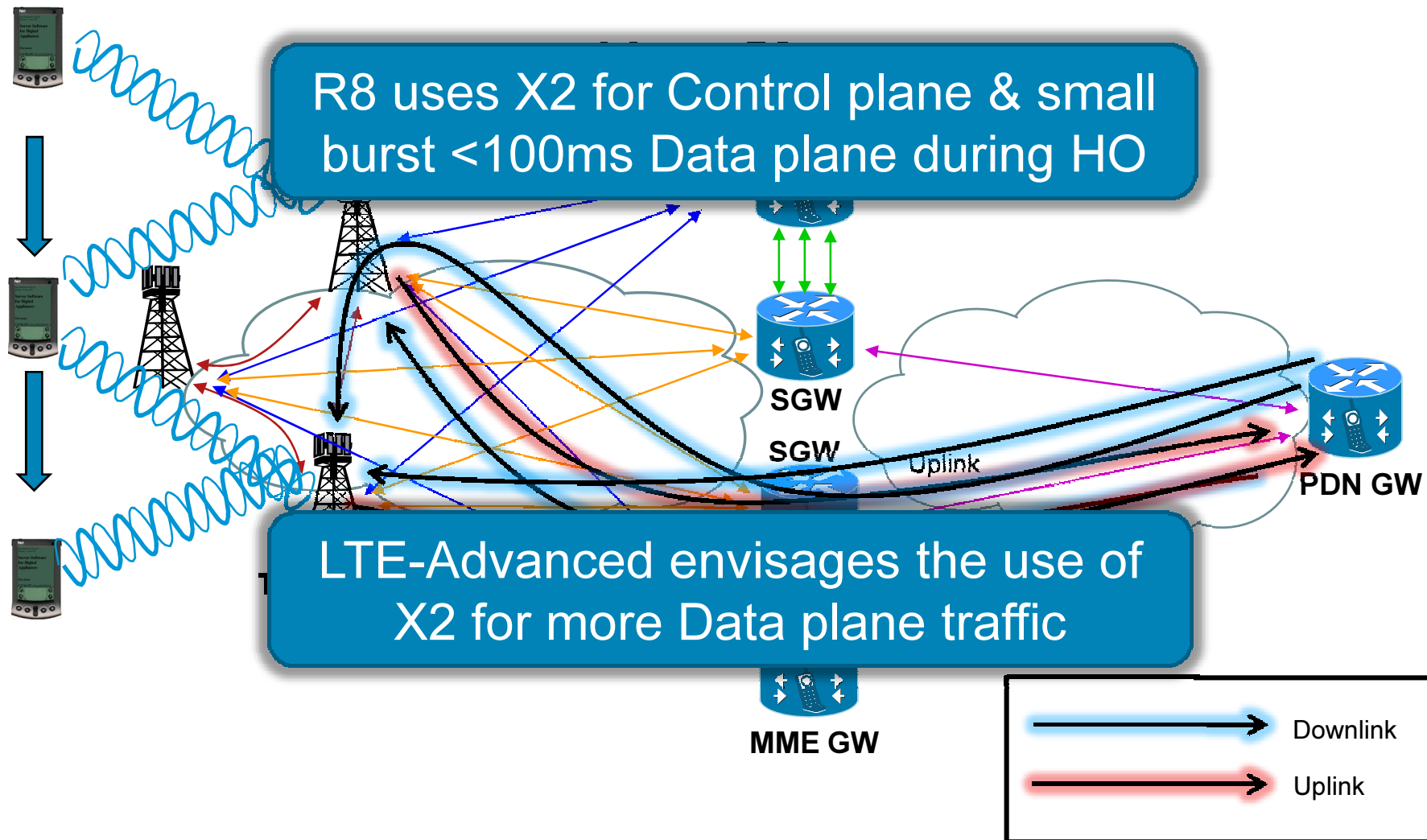

# Distributed Architectural Evolution

## 3GPP release evolution

2G and 2.5G Network Architecture

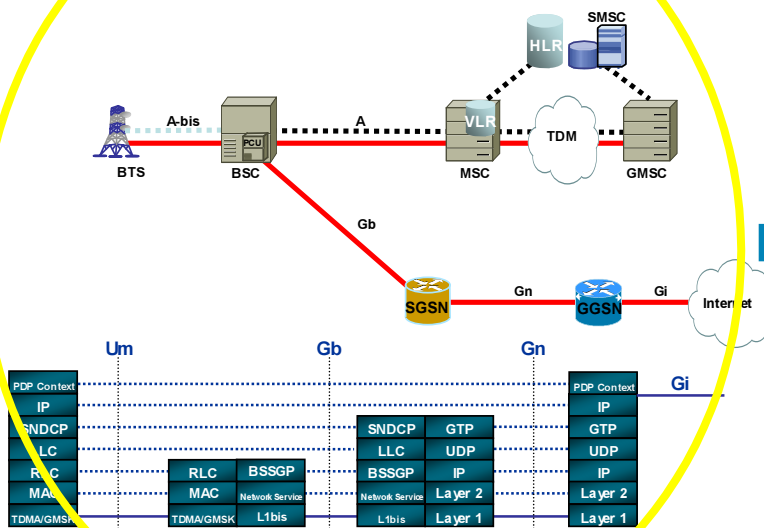

**Structured,  
Centralised  
Approach**

LTE/System Architecture Evolution

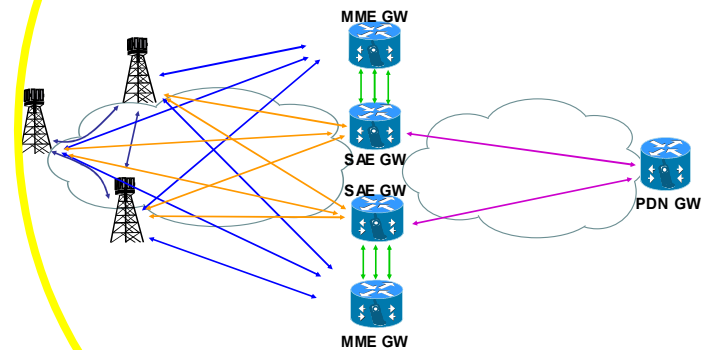

**Less Rigid, Flexible,  
Distributed Approach**

# Distributed Architectural Evolution

## Initial Plans

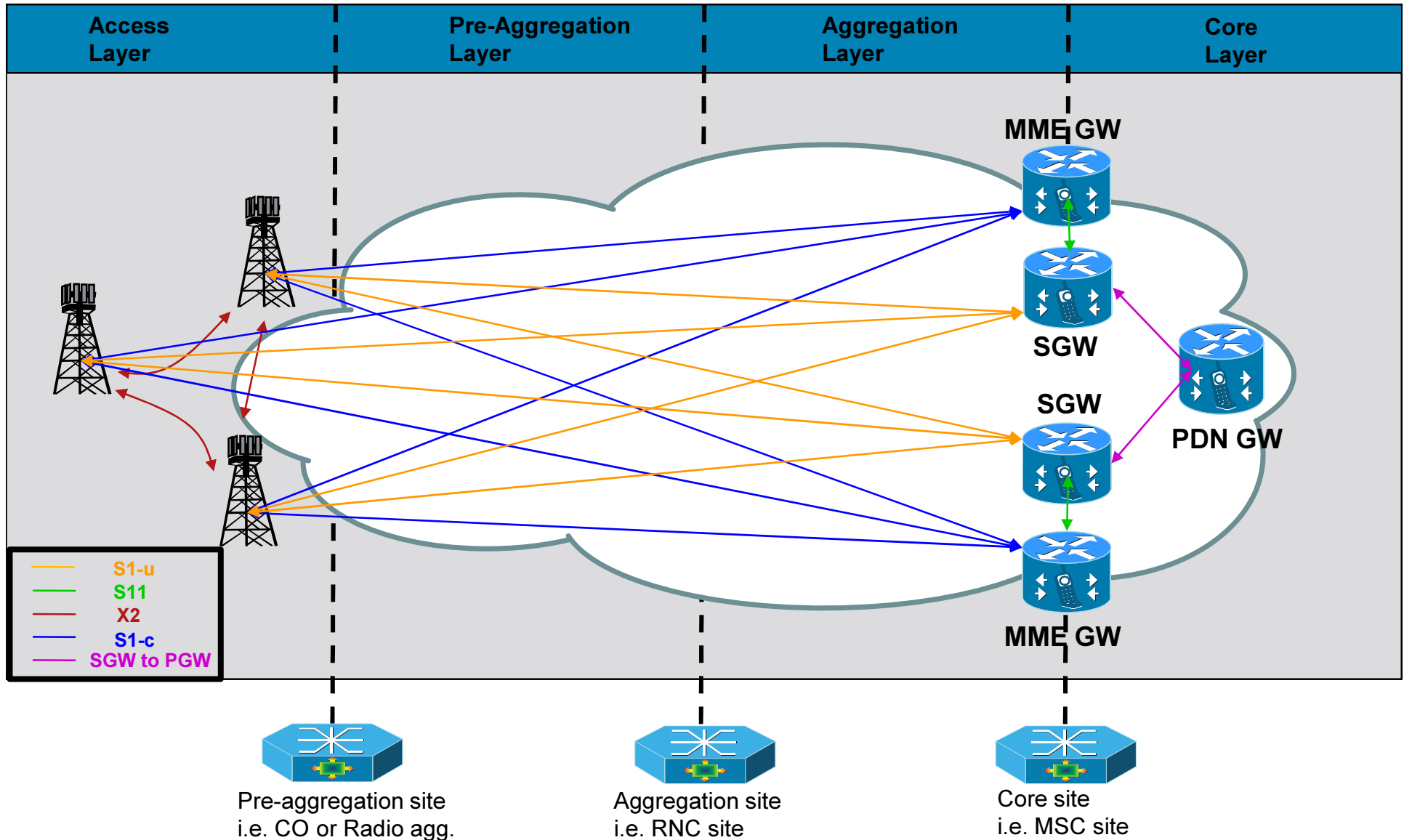

# Distributed Architectural Evolution

Evolving quickly to.....

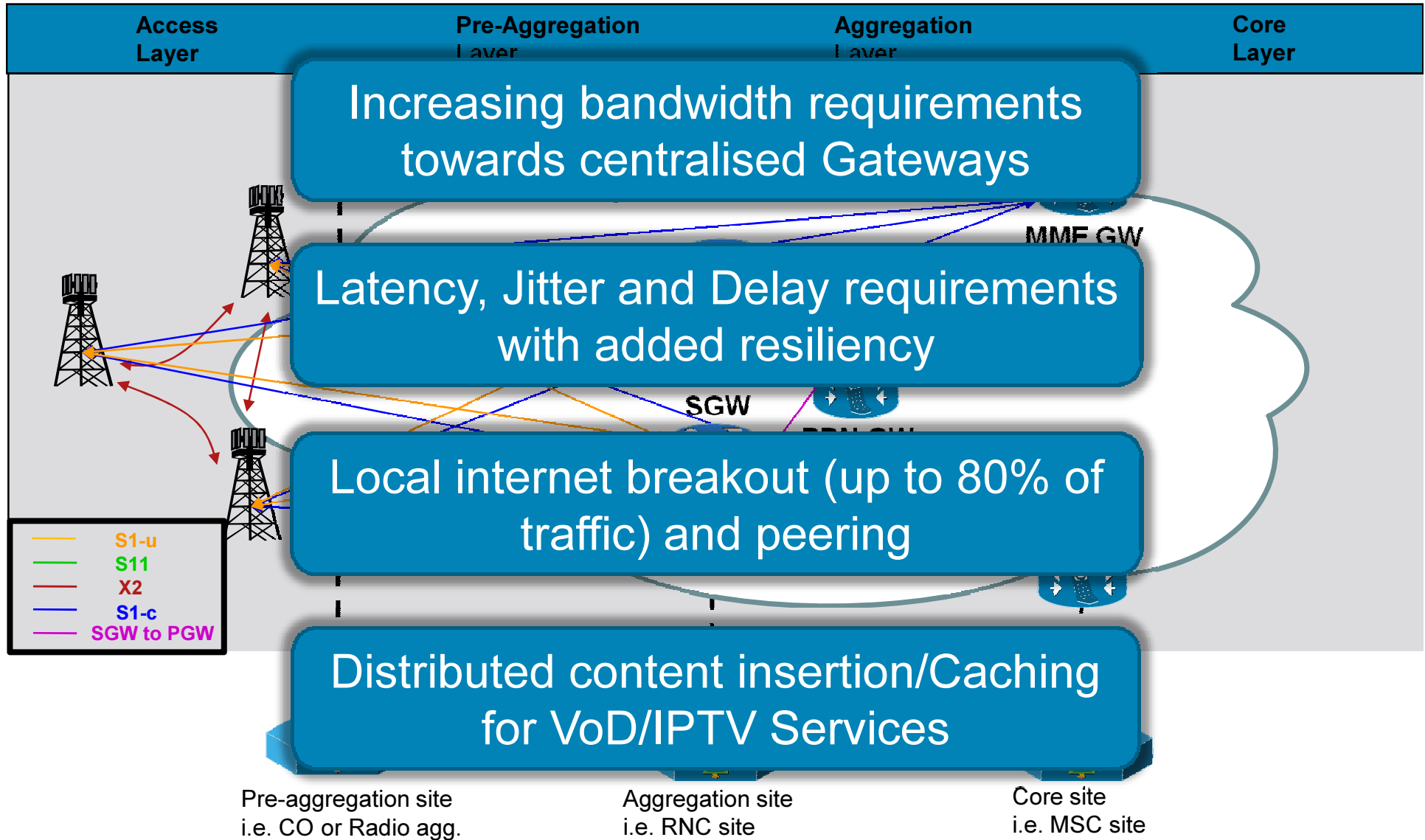



# Architectural and technology positioning for LTE deployments



# LTE Network Requirements

**S1-c Base interface**

Multi-homed to multiple MME pools  
SCTP/IP b

No longer Pt-to-Pt relationship with multipoint requirements

Different traffic types with different transport requirements

“X2” interface introduces direct communication between eNodeBs

Network intelligence for advanced services and traffic manipulation

**X2 inter base interface**

SCTP/IP Sign  
GTP tunneling  
following hand

More Distributed architecture for GW placement & local break-out

GTP or PMIP based macro mobility

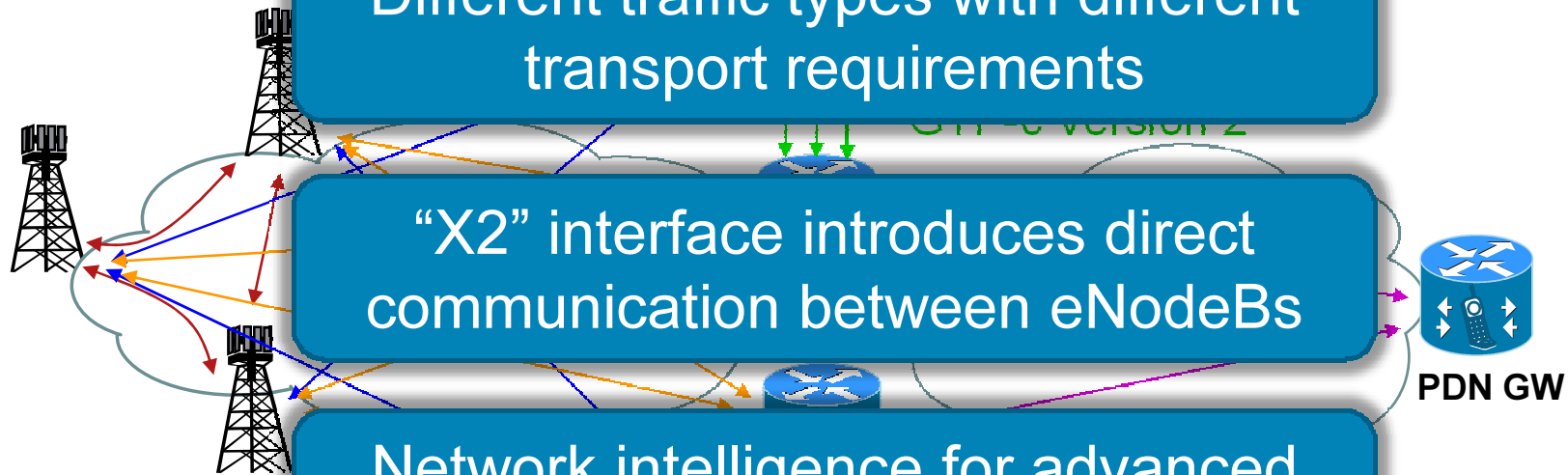

# Preferred LTE Deployment Option

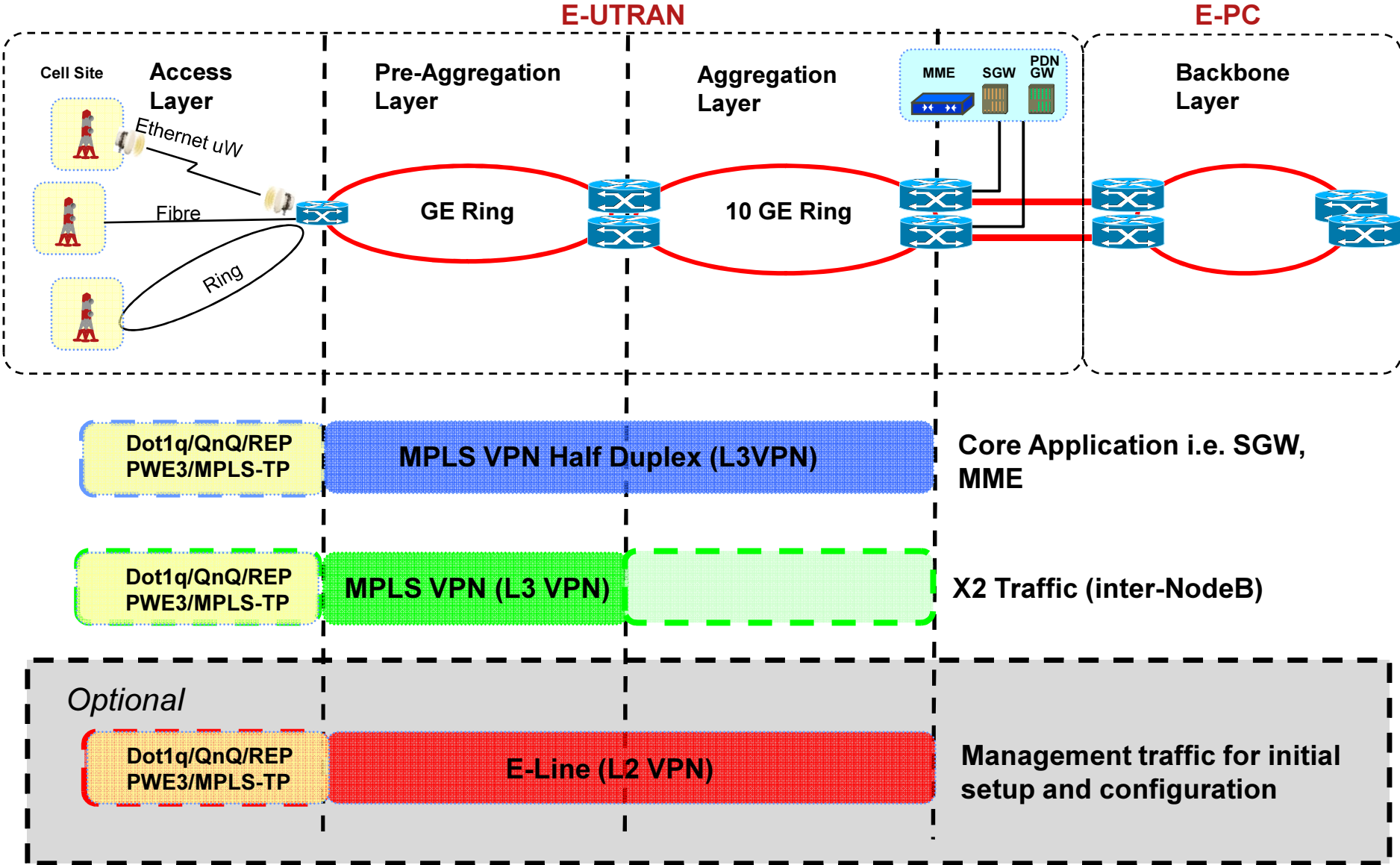

# MPLS-TP – An understanding of the offering

- MPLS Transport Profile

T-MPLS requirements feeding into IETF MPLS-TP enhancements

Effort to address Pt-to-Pt SDH-like transport centric networks

*Focused on connection-oriented services*

- **Question: Is this the desired direction for the Evolved Mobile Backhaul from end-to-end?**

No ECMP, no PHP, no LSP merging

- Control plane—static and/or dynamic

**Answer: It could form part of the solution but only offers subset of requirements**

- Key OAM enhancements

Enhanced OAM functionality

OAM Monitors and drives protection switching

- Standardization in progress, standard specs expected in 2009/2010

Driven by carrier's wishing to evolve SONET/SDH networks to support packet based services and networks, and the desire to take advantage of flexibility and cost benefits of packet switching technology

# European SP Transport Model Evaluation

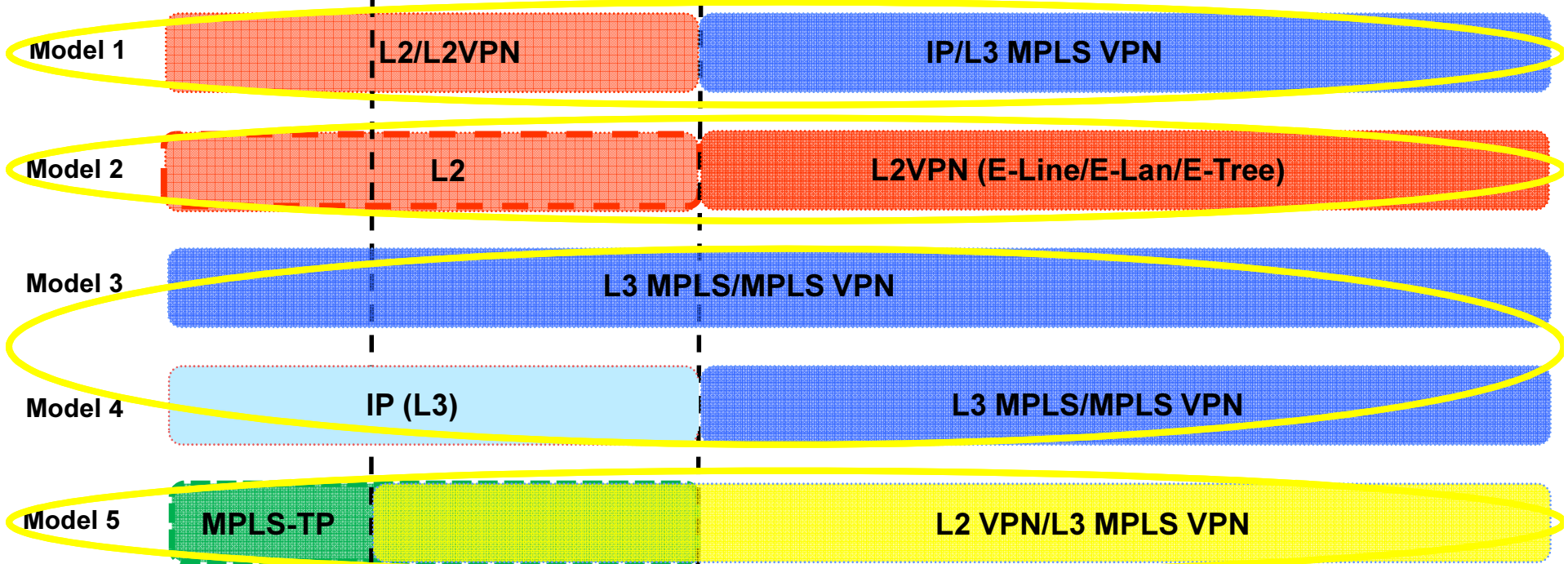
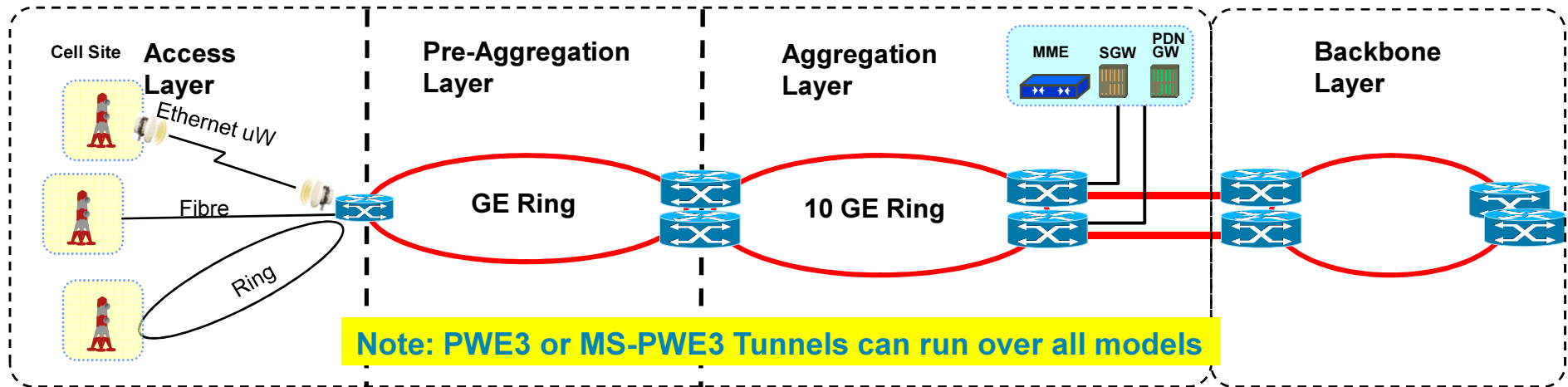



# Evolution towards a Converged IP NGN Architecture



# Converged IP Fixed & Mobile NGN

## Network Convergence

- Converged Wireless & Wireline offering with common Distributed L3 Edge

## Services Offering

- L2 VPN & L3 VPN, Residential & Business including IP, Multicast & Wholesale services

## Intelligent L3 Edge

- Distributed GW functions
- Bandwidth saving i.e. offload traffic
- Minimal Latency

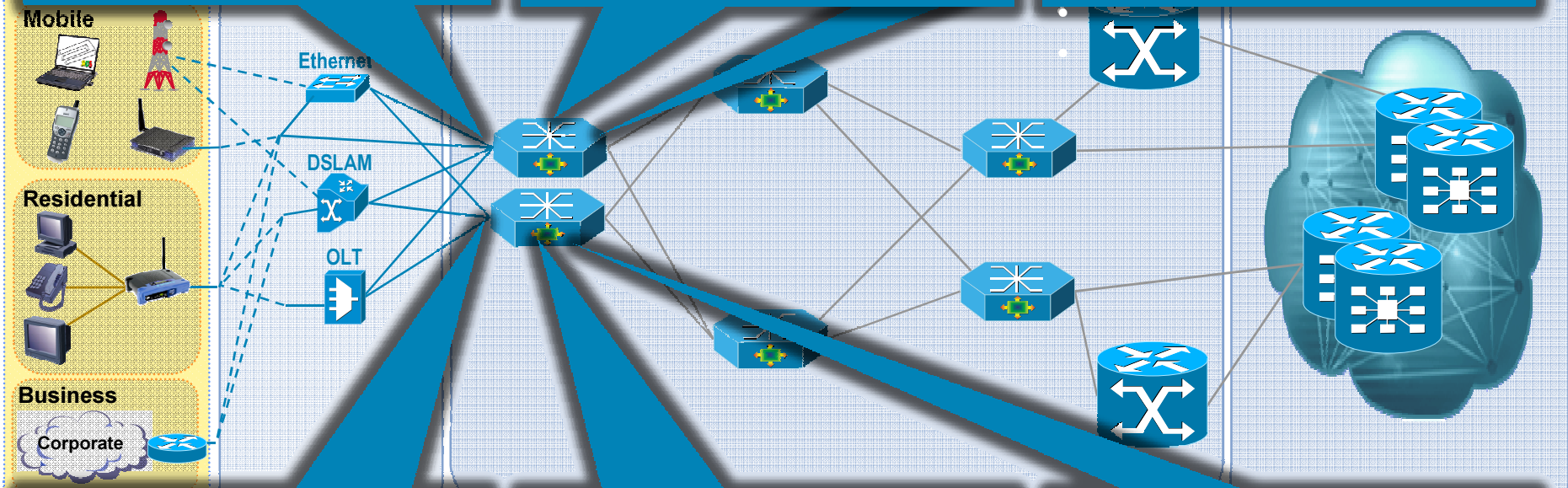

## Resiliency/Availability

- Common convergence & Resiliency technique with same Control plane to the Network edge

## Flexible UNI Architecture

- Traffic Flows identification
- VLAN manipulation
- Services application i.e. QoS, security, E-OAM

## Advanced Feature Set

- Security/IPSec
- IPv6 capability
- Synchronisation (SyncE, 1588v2, ACR)

# Converged IP Fixed & Mobile NGN

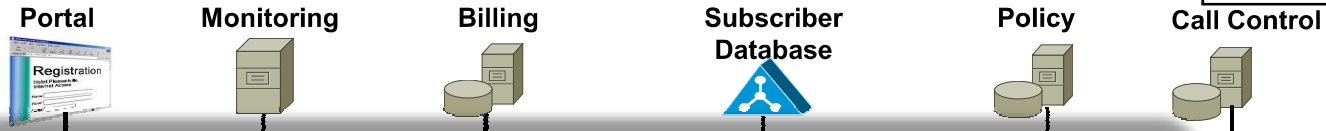
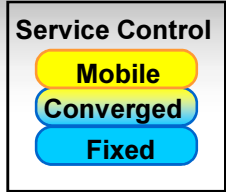

Common Application Integration and service control for all technology types

Common Access presentation with converged Aggregation networks

Flexible Service Edge placement with in-built network simplicity & optimisation

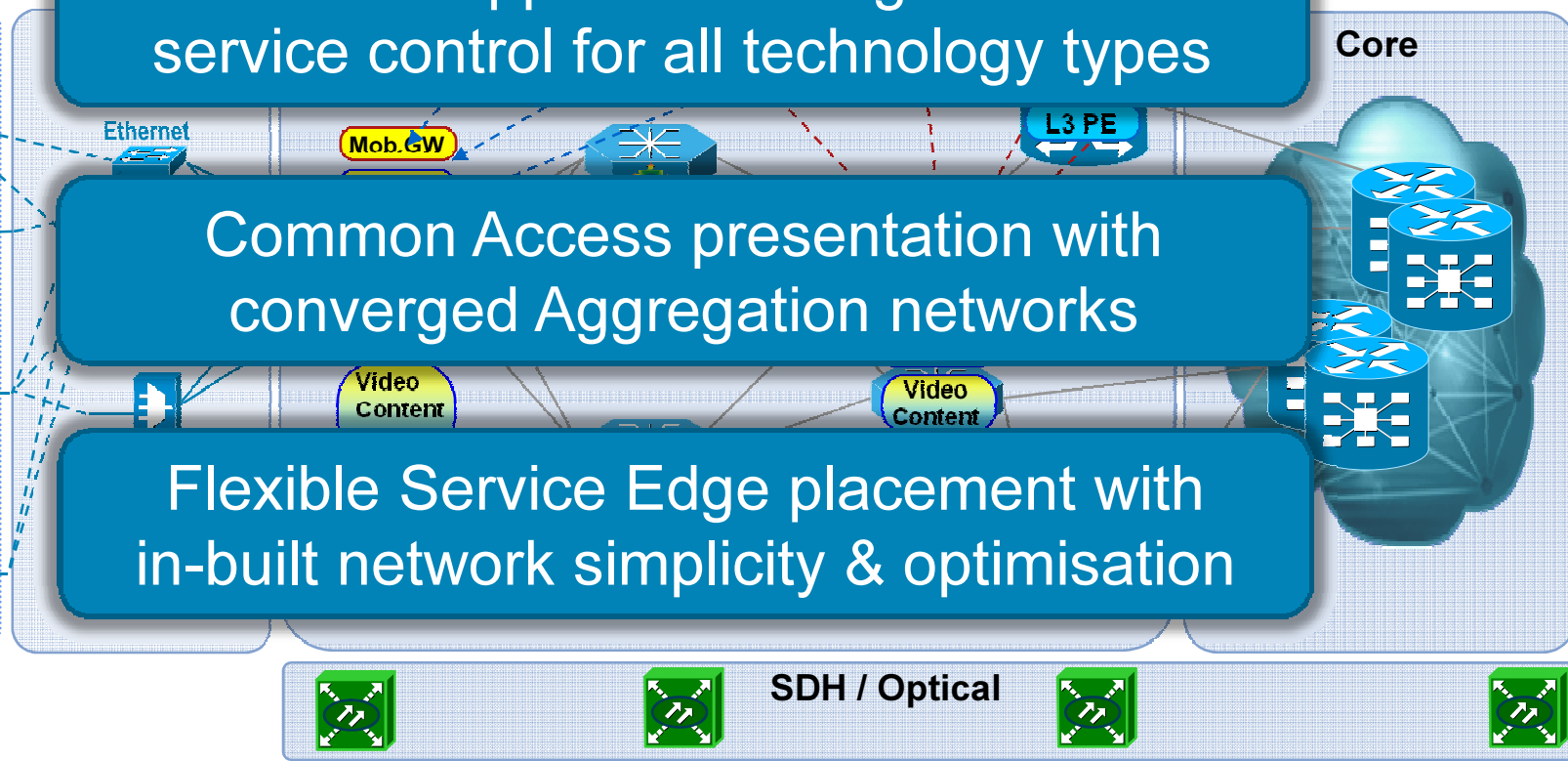
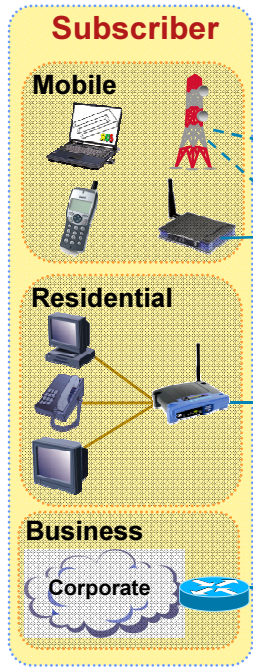

Mob. GW: GGSN, Serving-GW, PDN-GW, PDG (3G, 4G, Femto) HA, ASN-GW (WiMAX), Security Gateway

L2/L3 BNG: ISG PPP/IP/L2 Sessions, DHCP, Carrier Ethernet, IPv4/IPv6, H-QoS



**CISCO**