



## Packet Tracer

**Darko Parić**  
**CARNet**



Cisco Expo  
2009

Cavtat, Hotel Croatia  
01. - 03. travanj 2009.

Experience Today the  
Network of Tomorrow

Sponzor konferencije



Partner digitalnog oglašavanja



Partneri konferencije



Pokrovitelji konferencije



Tehnološki sponzori



Medijski sponzori



# Cisco Expo 2009

Cavtat, Hotel Croatia  
01. - 03. travanj 2009.

Experience Today the  
Network of Tomorrow



# Sadržaj

- Packet Tracer osobine i funkcionalnost
- Primjer korištenja PT-a
- Napredno korištenje PT-a (Activity Wizard)
- Prednosti korištenja PT-a

# Packet Tracer

- PT je simulacijski softver koji omogućava lako i jednostavno učenje mrežnih tehnologija
- PT nije zamišljen kao zamjena za mrežnu opremu u laboratoriju, on je dodatak opremi

Cisco Networking Academy  
Mind Wide Open™

## Packet Tracer 5.0

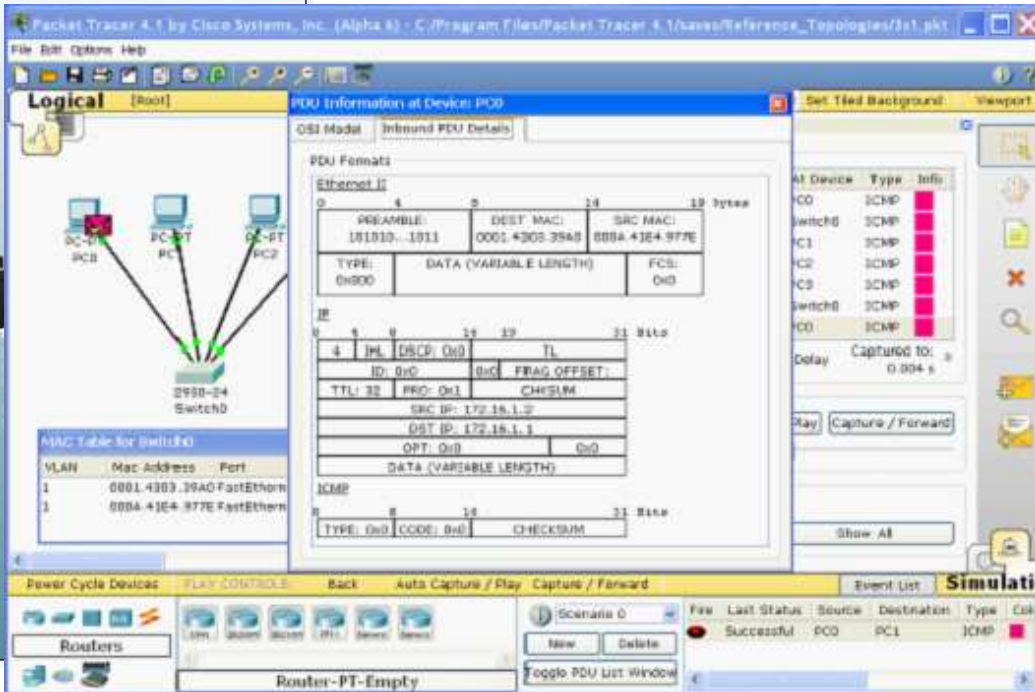

The screenshot displays the Packet Tracer 5.0 interface. On the left, there is a network topology diagram showing a central switch (S2930-24) connected to three PCs (PC1, PC2, PC3). Below the topology is a MAC table for switch S2930-24:

VLAN	Mac Address	Port
1	0001.4303.39AD	FastEthernet0/24
1	000A.43E4.877E	FastEthernet0/24

The main window shows the 'PDU Information at Device: PC0' window, displaying the following details:

OSI Model: Inbound PDU Details

PDU Format:

Ethernet II		
0	4	14
PREAMBLE:	DEST. MAC:	SRC MAC:
101010...1011	000A.43E4.877E	0001.4303.39AD
TYPE: DATA (VARIABLE LENGTH) FCS: 0x00		

IP:

IP		
4	8	12
VERSION:	TYPE OF SERVICE:	TTL:
4	0	64
ID: 0x0 FRAG. OFFSET: 0		
TTL: 32 PRO: 0x1 CHECKSUM: 0x0000		
SRC IP: 172.16.1.1		
DST IP: 172.16.1.1		
OPT: 0x0		
DATA (VARIABLE LENGTH)		

ICMP:

ICMP		
0	8	16
TYPE:	CODE:	CHECKSUM:
8	0	0x0000

At the bottom, the 'Event List' window shows a successful ICMP packet capture from PC0 to PC1.

© Copyright Cisco 2008

# Mogućnosti PT-a

## PT 4.11

- Simulacija i vizualizacija većine općih CCNA protokola
- Podrška za Win 2K, XP platforme
- Korištenje za učenje, laboratorije, domaće zadaće, ispite
- Besplatan za sve studente i instruktore

## PT 5.1

Sve dosadašnje osobine plus:

- Podrška za dodatne protokole (npr., IPv6)
- Podrška za nove platforme (Linux, Vista)
- Podrška za korištenje više korisnika istovremeno

## Mogućnosti PT-a (cont)

- Podrška za nove operativne sustave

  - Windows (Windows XP, Windows 2000)

  - Vista (Vista Basic, Vista Premium)

  - Linux (Ubuntu, Fedora)

- Podrška za dodatne napredne protokole

  - Kako bi podržavao kretanja u mrežnom svijetu povećana je lista naprednih protokola koje PT podržava

- Podrška za istovremeno korištenje više korisnika

  - Mogućnost učenja u grupama umjesto pojedinačnog

  - PT 5.0 je postala mrežna tzv. (peer to peer) aplikacija

  - Dodana je podrška za zajednički (grupni) rad, natjecanja, istovremeni rad nekoliko studenata preko mreže, igranje

# Protokoli koje PT podržava

- HTTP, TFTP, Telnet, **SSH**, DNS, DHCP
- TCP and UDP
- IPv4, ICMP, ARP, **IPv6, ICMPv6**
- RIPv1/v2/ng, **Multi-Area OSPF**, EIGRP, Static Routing, **Route Redistribution, Multilayer Switching**
- Ethernet (802.3), HDLC, Frame Relay, PPP
- STP, **RSTP**, VTP, DTP, CDP, 802.1q, **PAgP**
- 802.11

**\*Protokoli podržani u verziji PT 5.1**

# PT Multiuser funkcionalnost

- PT je realiziran kao mrežna aplikacija (peer to peer) koja omogućava korištenje preko mreže (TCP protokol)
- PT aplikacija koja radi na jednom računalu na mreži može komunicirati istovremeno sa PT aplikacijama na jednom ili više računala u mreži
- Ova osobina istovremenog rada na PT više korisnika na mreži omogućava podršku za grupni rad, kolaboraciju, natjecanja i na kraju udaljenu instruktor-student interakciju



# Primjer Multiuser scenarija

3 različite mogućnosti interakcije koristeći Packet Tracer Messaging Protocol (PTMP)

2 tima,  
1 instruktora

3 različita  
razreda

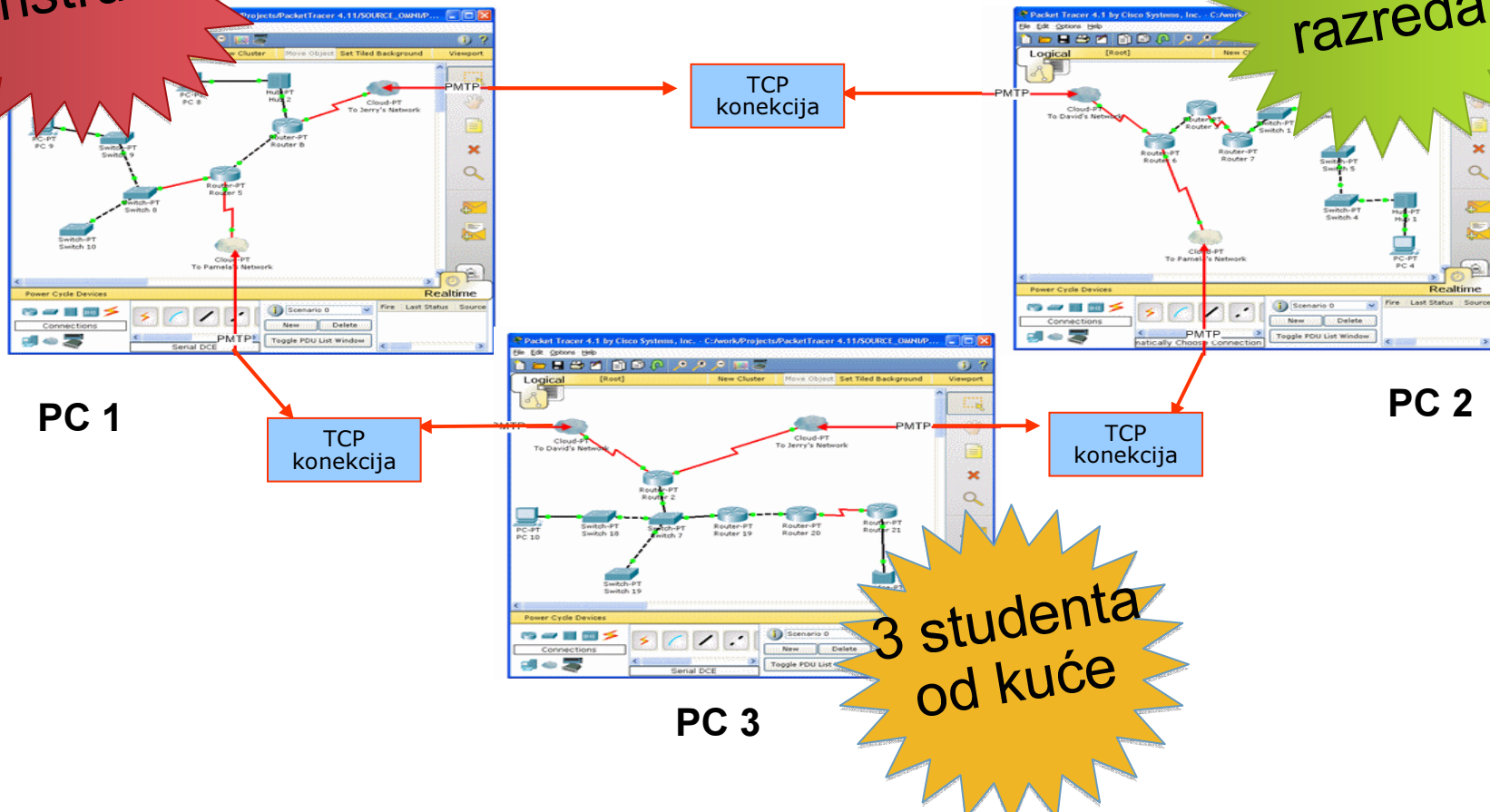

3 studenta  
od kuće

# Simulacija, Vizualizacija, Kolaboracija

The screenshot displays the Packet Tracer 4.0 interface. On the left, the 'CLI' window shows the 'IOS Command Line Interface' for 'SiteB'. The command prompt is 'SiteB#'. The output shows the configuration of static routes for various IP addresses (192.168.0.0/24, 192.168.0.129/27, 192.168.0.163/27, 192.168.0.192/27, 192.168.0.224/30, 192.168.0.229/30, 192.168.0.232/30) and the successful execution of the 'show ip route' command. The main window shows a network diagram with two routers (Router1 and Router2) connected to two switches (Switch1 and Switch2) and two PCs (PC1 and PC2). The 'Simulation Panel' on the right shows an 'Event List' with the following data:

Vis.	Time (s)	Last Device	At Device	Type	Info
	0.001	PC1	Switch1	ICMP	
	0.002	Switch2	Router2	ICMP	
	0.002	Switch0	Router0	ICMP	
	0.002	Switch1	Router1	ICMP	
	0.003	Router2	Router0	ICMP	
	0.003	Router0	Router1	ICMP	
	0.003	Router1	Router2	ICMP	

Below the event list, there are 'Play Controls' (Back, Auto Capture / Play, Capture / Forward) and 'Event List Filters' (ARP, EIGRP, TCP, CDP, ICMP, UDP). The bottom status bar shows 'Time: 00:10:42' and 'Power Cycle Devices'.

Simulira IOS naredbe

Vizualizira mrežni promet

Istovremeno korištenje više korisnika

# Simulacija realnih mreža

The image displays two overlapping windows of Packet Tracer 4.0. The top window shows a network topology with two routers (Router0 and Router1) connected to four switches (Switch0-3) and four PCs (PC0-3). A red line indicates a connection between Router0 and Router1 labeled '2 users'. Text instructions on the right side of the window read: 'Subnet the 192.1.1.0/24 network address using VLSM to satisfy the user requirements for this network topology. Use RIP v2 to support the VLSM routing. Configure the routers and host devices. Test the network operation using pings between the host devices and routers. Don't forget to save your configurations! (copy run start) Save the file and bring to class or email to dmiller@nhctc.edu'. The bottom window shows a similar topology but with a 'Command Prompt' window open, displaying the command 'PC>tracert 192.168.1.2' and its output: 'Tracing route to 192.168.1.2 over a maximum of 30 hops: 1 4 ms 2 ms 2 ms 192.168.3.1 2 4 ms'. Below the command prompt is the 'PDU Information at Device: Router1' window, showing details for an Ethernet II frame and an IP packet. The Ethernet II frame details include: PREAMBLE: 1010 1010, DEST MAC: 00E0.F933.5E48, SRC MAC: 000D.BD99.1B1B, TYPE: 0x800, DATA (VARIABLE LENGTH), and FCS: 0x0. The IP packet details include: IHL: 4, DSCP: 0x0, TL, ID: 0x0, FRAG OFFSET: 0x0, TTL: 2, PRO: 0x1, CHKSUM, SRC IP: 192.168.3.2, and DST IP: 192.168.1.2.

Packet Tracer 4.0 by Cisco Systems, Inc. - C:/Documents and Settings/dfrezzo/Local Settings/Temporary Internet Files/OLK242/121hwVLSM.pkt

File Options Help

Logical Set Tiled Background

Router0-PT Router1-PT Router0 Router1

2950-24 Switch0 2950-24 Switch1 2950-24 Switch2 2950-24 Switch3

PC-PT PC0 PC-PT PC1 PC-PT PC2 PC-PT PC3

55 users 28 users 12 users 100 users

Subnet the 192.1.1.0/24 network address using VLSM to satisfy the user requirements for this network topology.  
Use RIP v2 to support the VLSM routing.  
Configure the routers and host devices. Test the network operation using pings between the host devices and routers.  
Don't forget to save your configurations! (copy run start)  
Save the file and bring to class or email to dmiller@nhctc.edu

Packet Tracer 4.0 by Cisco Systems, Inc. - C:/Program Files/Packet Tracer 4.0/saves/CCNA2/SkillBuilder\_Traceroute/6C2TracerouteAnswerNetwork...

File Options Help

Logical Set Tiled Background

2621XM Router0 2621XM Router2 2621XM Router1

PC-PT PC0 PC-PT PC1

Command Prompt

Packet Tracer PC Command Line 1.0  
PC>tracert 192.168.1.2  
Tracing route to 192.168.1.2 over a maximum of 30 hops:  
1 4 ms 2 ms 2 ms 192.168.3.1  
2 4 ms

PDU Information at Device: Router1

OSI Model Inbound PDU Details Outbound PDU Details

PDU Formats

Ethernet II

0	4	8	14	19	Byte
PREAMBLE:	1010 1010	DEST MAC:	00E0.F933.5E48	SRC MAC:	000D.BD99.1B1B
TYPE:	0x800	DATA (VARIABLE LENGTH)		FCS:	0x0

IP

0	4	8	16	19	31	Bits
4	IHL	DSCP: 0x0	TL			
ID: 0x0	FRAG OFFSET: 0x0					
TTL: 2	PRO: 0x1	CHKSUM				
SRC IP: 192.168.3.2						
DST IP: 192.168.1.2						

# Primjeri mrežnih topologija u PT

- Files -> Open -> saves -> Reference\_Topologies

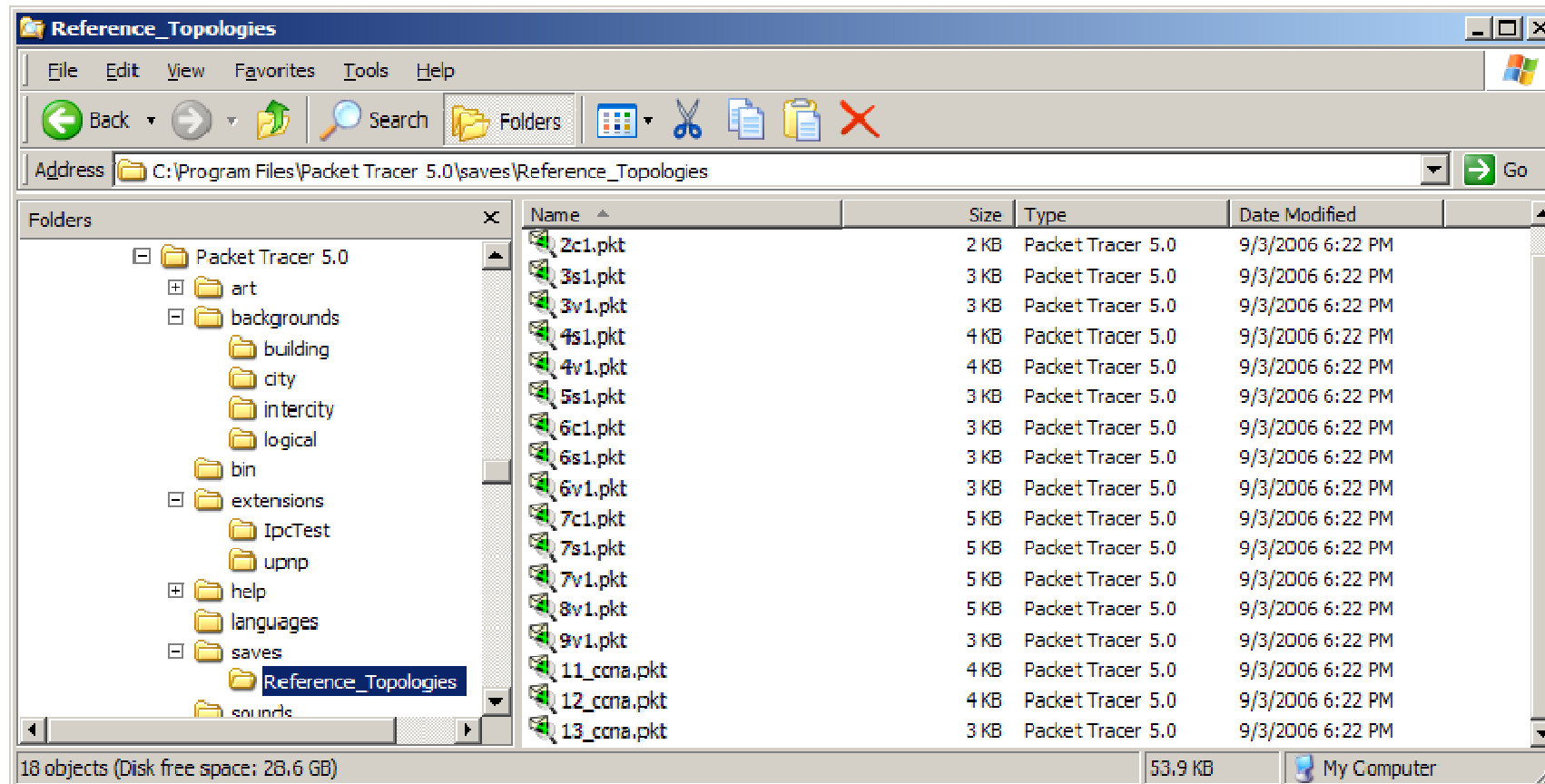

# Pomoć i upute

## Packet Tracer 5.0

**Search**

**Introduction**  
What's New  
Program Usage

**Getting Started**  
Interface Overview  
My First PT Lab

**Tutorials**

**Workspace Basics**  
Logical Workspace  
Physical Workspace  
Moving Devices  
Wireless Devices  
Special Notes

**Operating Modes**  
Realtime Mode  
Simulation Mode  
PDU Information  
Scenarios  
Complex PDUs  
Special Notes



**Connections / Links**

**Devices & Modules**  
Routers  
Switches  
End Devices  
Other Devices

**Configuring Devices**

Cisco Networking Academy®  
Mind Wide Open™

## Packet Tracer 5.0



© Copyright Cisco 2008

**Using the Help Files**

The help files are designed to familiarize users with the Packet Tracer 5.0 interface, functions, and features. Although the help files may be used as a reference guide, the pages are meant to be read in order (especially the sections presented at the beginning). Annotated screenshots are used to aid your understanding. Important notes or tips are presented in tip boxes like the following:

If you are a first-time user, please read the help files in order.

# Kompletno integriran u CCNA program!

The image displays a screenshot of the CCNA Exploration Network Fundamentals interface. The main window shows a lesson titled "7.4.1 Follow Data Through an Internetwork" with a progress indicator showing step 3 of 3. Below the lesson title, there is a text box stating: "In this activity, you can examine in further detail the step-by-step animation on the previous page." To the right, a "Packet Tracer Exploration: Packet Tracing Across an Internetwork" window is open, featuring a collage of images including a woman, a globe, and network equipment. Overlaid on this is the Packet Tracer 5.0 application window. The Packet Tracer window shows a logical network diagram with a "Server-PT Server" connected to "Router\_A" (1841), which is connected to "Router\_B" (1841), which is connected to a "PC-PT Client". A "PT Activity" window is also open, titled "7.4.1: Packet Tracing Across An Internetwork", with an introduction and objectives section. The Packet Tracer interface includes a menu bar, a toolbar, and a "Realtime" panel at the bottom with various device icons and a "Power Cycle Devices" button.

Studenti mogu pokrenuti PT direktno iz CCNA Discovery i CCNA Exploration lekcija pri otvaranju laboratorijskih vježbi

# Dostupnost PT-a

- Dostupan je besplatno svim instruktorima, studentima i alumnima Cisco akademije na Academy Connection stranicama
- Kako bi skinuli Packet Tracer

Logirajte se na Academy Connection strane

Kliknite na Packet Tracer sliku na lijevoj strani web sučelja gdje ste se logirali



Odaberite download kako biste skinuli PT aplikaciju

## Primjer korištenje PT-a

### Problem:

Studenti trebaju naučiti kako konfigurirati Ethernet sučelje na routeru, kako provjeriti vezu s tim sučeljem sa PC-a koji je podešen da bude dio te mreže.

- Kako ovaj proces demonstrirati cijeloj grupi?
- Kako će studenti poslije ponoviti simulaciju?
- Kako testirati sposobnost svakog studenta da ponovi ovaj scenarij?

**Rješenje je Packet Tracer!**

# Topologija za učenje

## *Instruktor:*

- Počinjemo sa gotovom topologijom.
- Studente provodimo kroz proces korak po korak.

## *Studenti:*

- Studenti će vođeni instruktorom kreirati uređaje, veze i konfigurirati sve uređaje.
- Studenti će također testirati vezu između PC-a i routera.

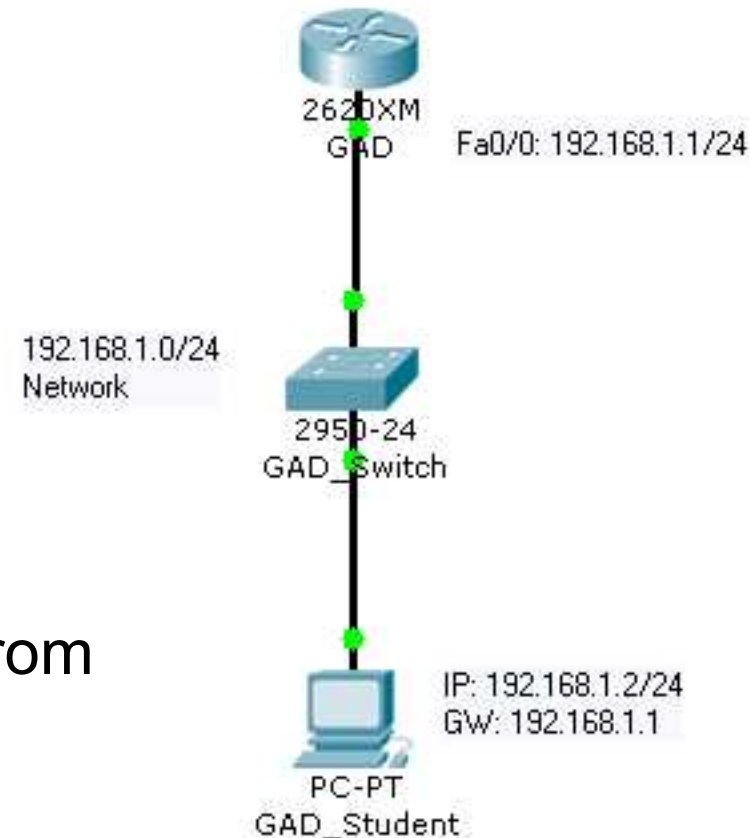

# Tehnike koje će studenti svladati

- Kreiranje i postavljanje uređaja
- Podešavanje veza među uređajima
- Konfiguriranje uređaja
- Provjera veza
- Simulacijski način korištenja PT-a

# Uobičajeni alati PT-a

The screenshot displays the Packet Tracer (PT) interface. At the top, a yellow header bar contains the text "Logical [Root]" and several menu options: "New Cluster", "Move Object", "Set Tiled Background", and "Viewport". The main workspace shows a network topology with three devices: a "2620XM Router0", a "2950-24 Switch0", and a "PC-PT PC0". On the right side, a vertical toolbar is highlighted with a red box. Four red arrows point from text boxes to specific icons in this toolbar: a dashed box with a mouse cursor, a hand, a document, and a red 'X'. Below the main workspace, a yellow bar labeled "Power Cycle Devices" contains a "Realtime" button. At the bottom, there are panels for "End Devices" (with icons for Generic, Generic, Generic, and IPPhone) and a "Scenario 0" panel with "New" and "Delete" buttons, and a table with columns "Fire", "Last Status", "Source", and "Destination".

**Alati za korištenje:**

- Select** alat za označavanje
- Move** alat za micanje cijele topologije
- Note** za dodavanje zabilješki bilo gdje u topologiji
- Delete** za brisanje uređaja i linkova

# Uobičajeni alati PT-a

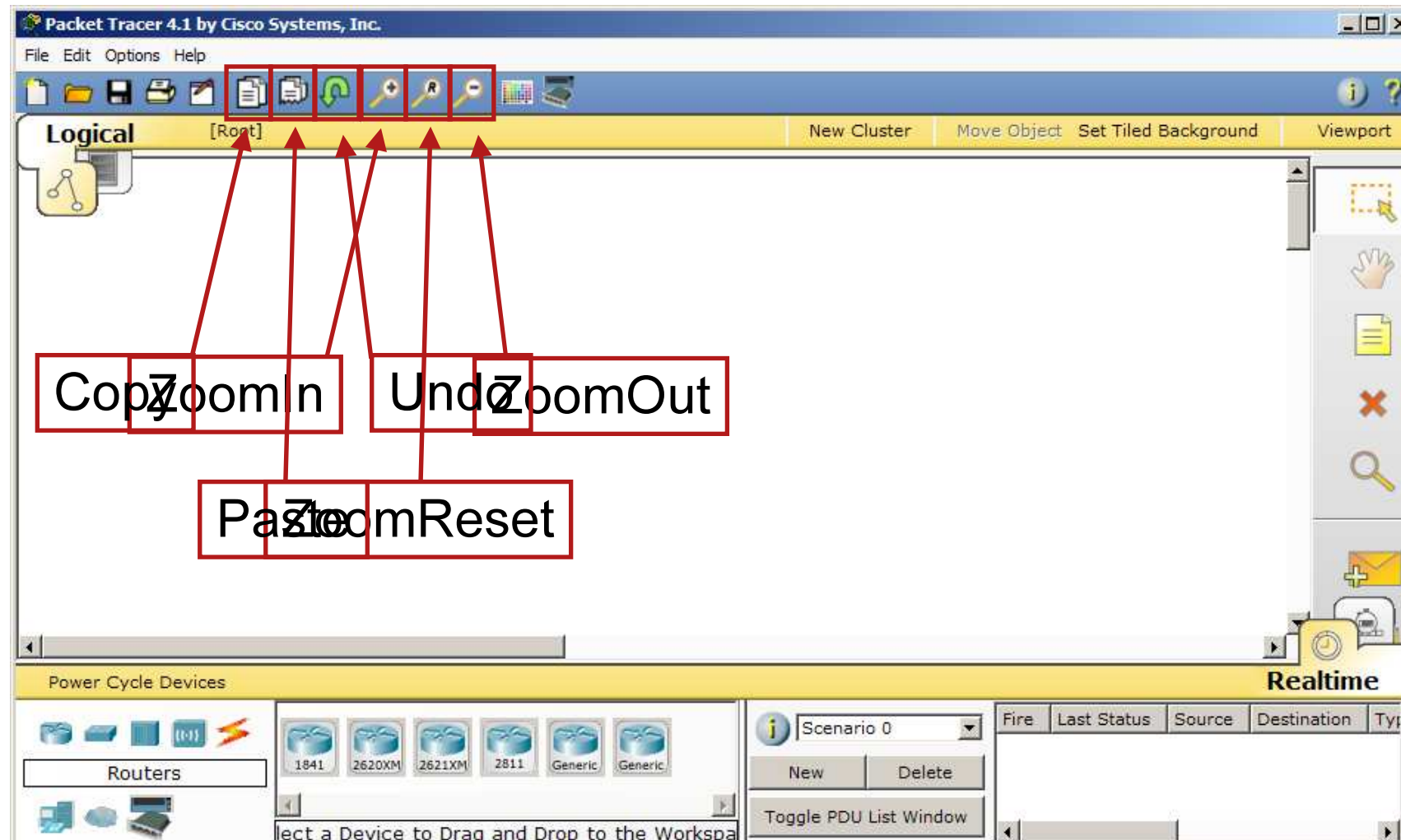

# Kreiranje i postavljanje uređaja

**Logical** [Root] New Cluster Move Object Set Tiled Background Viewport

**Za kreiranje uređaja:**

1. Klik na Select alat
2. Odaberi tip uređaja.
3. Odaberi uređaj.
4. Klikni na radni prostor.

2620XM Router0

Power Cycle Devices

**Realtime**

Scenario 0 Fire Last Status Source Destination

New Delete

Toggle PDU List Window

Routers

1841 2620XM 2621XM 2811 Generic Generic

# Povezivanje uređaja

**Logical** [Root] New Cluster Move Object Set Tiled Background Viewport

**Povezivanje uređaja:**

1. Klikni na alat Select.

2. Izaberi opciju veza.

3. Izaberi ikonu za serijsku vezu.

4. Klikni na prvi uređaj.

5. Klikni na drugi uređaj.

2620XM Router0

2950-24

PC-PT PC0

Power Cycle Devices

Connections

Scenario 0

New Delete

Toggle PDU List Window

Fire	Last Status	Source	Destination
------	-------------	--------	-------------

**Realtime**

# Status portova na uređajima

The screenshot shows a network simulation interface with a topology consisting of three devices: a 2621XM Router0 at the top, a 2950-24 Switch0 in the middle, and a PC-PT PC0 at the bottom. The links between the router and switch, and between the switch and PC, are marked with red 'X' symbols, indicating they are down. A red arrow points from a text box to the link between the router and switch. Another text box is positioned below the switch.

Crveno inicira da su linkovi ugašeni (down)

Defaultno stanje linkova je ugašeno (shutdown).

The interface includes a top menu bar with options like 'New Cluster', 'Move Object', 'Set Tiled Background', and 'Viewport'. A toolbar on the right contains various icons for navigation and editing. At the bottom, there is a 'Power Cycle Devices' section, a 'Connections' panel, and a 'Realtime' section with a table for monitoring events.

Fire	Last Status	Source	Destination
------	-------------	--------	-------------

# Konfiguriranje uređaja

- U ovom primjeru pretpostavljamo da studenti ne znaju konfigurirati uređaje putem klasičnog CLI sučelja ili da su tek početnici pa ćemo koristiti GUI sučelje za sve.
- PT omogućava konfiguraciju svih uređaja u klasičnom CLI modu, ali isto tako osnovne konfiguracijske postavke se mogu napraviti u grafičkom sučelju.

# Podešavanje imena routera

The screenshot shows a network configuration interface with a topology on the left and a configuration panel for 'Router0' on the right. The topology includes a '2621XM GAD' router and a 'PC-PT PC0'. The configuration panel has tabs for 'Physical' and 'Config', with 'Config' selected. The 'Global Settings' section shows 'Display Name' and 'Hostname' both set to 'GAD'. Below this is a terminal window titled 'Equivalent IOS Commands' showing the configuration commands: 'Router#configure terminal', 'Enter configuration commands, one per line. End with CNTL/Z.', 'Router(config)#hostname GAD', and 'GAD(config)#'. A toolbar on the right includes icons for save, delete, search, and a 'realtime' indicator.

2. Upiši ime uređaja u oba polja; jedno za **Display Name** i jedno za **Hostname**

1. Za podešavanje uređaja, klik na uređaj pa potom izbor na **Config** tab.

3. Ime uređaja se ažurira u topologiji.

4. Odgovarajuće IOS komande se ispisuju u ovom polju.

# Podešavanje FastEthernet sučelja

1. Klik na sučelje kako bi ga podesili.

3. Aktivirajte sučelje.

4. IOS komande se ažuriraju i sučelje je sada zeleno.

2. Upišite IP adresu i mrežnu masku.

Logical [Root] New Cluster Move Object Set Tiled Background Viewport

GAD

Physical Config CLI

GLOBAL

Settings

ROUTING

Static

RIP

INTERFACE

FastEthernet0/0

FastEthernet0/0

Port Status  On

Bandwidth  Auto

10 Mbps 100 Mbps

Duplex  Auto

Full Duplex Half Duplex

MAC Address 0007.EC69.76D3

IP Address 192.168.1.1

Subnet Mask 255.255.255.0

Equivalent IOS Commands

```
GAD(config-if)#
GAD(config-if)#exit
GAD(config)#interface FastEthernet0/0
GAD(config-if)#
```

Power Cycle Devices

Connections

Automatically Choose Connection Type

New Delete

Toggle PDU List Window

# Podešavanje gateway-a na PC-u

The screenshot displays a network configuration interface. On the left, a logical network diagram shows a 2621XM GAD router connected to a PC-PT GAD\_Student. The main window is titled 'PC0' and has tabs for 'Physical', 'Config', and 'Desktop'. The 'Config' tab is active, showing a tree view with 'GLOBAL Settings' selected. The 'Global Settings' panel is open, showing fields for 'Display Name' (GAD\_Student), 'Gateway/DNS' (Static selected), 'Gateway' (192.168.1.1), and 'DNS Server'. A red arrow points from a text box to the 'Config' tab. Another red box highlights the 'Global Settings' panel.

Klik na PC i nakon toga izbor na **Config** tab.

Pod GLOBAL Settings, možete promijeniti ime računala i upisati IP adresu i gateway.

# Podešavanje IP adrese PC-a

The screenshot displays a network configuration interface. On the left, a logical network diagram shows a router labeled '2620XM GAD' connected to a PC labeled 'PC-PT GAD\_Student'. The main window is titled 'PC0' and has tabs for 'Physical', 'Config', and 'Desktop'. The 'Config' tab is active, showing a tree view on the left with 'GLOBAL' selected, and 'INTERFACE' expanded to show 'FastEthernet'. A red arrow points from a text box to the 'FastEthernet' entry. The right pane shows the configuration for the 'FastEthernet' interface. The 'Port Status' is checked 'On'. 'Bandwidth' is set to '100 Mbps' (selected over '10 Mbps'). 'Duplex' is set to 'Auto' (selected over 'Full Duplex' and 'Half Duplex'). The 'MAC Address' is '00E0.B043.9EE8'. Under 'IP Configuration', 'Static' is selected (over 'DHCP'). The 'IP Address' is '192.168.1.2' and the 'Subnet Mask' is '255.255.255.0'. A red arrow points from the text box to the 'IP Address' field. The bottom of the interface includes a 'Power Cycle Devices' section, a 'Connections' toolbar, and a 'realtime' status indicator.

Klik na FastEthernet pod INTERFACE kako bi podesili IP adresu i mrežnu masku.

# Dodavanje bilješki

The screenshot shows a network simulation interface with a topology consisting of three main components: a 2620XM GAD router at the top, a 2950-24 Switch0 in the middle, and a PC-PT GAD\_Student at the bottom. The router's Fa0/0 interface is configured with the IP address 192.168.1.1/24. A red box highlights a note icon in the right-hand toolbar, with two red arrows pointing from it to the note icon and the PC icon in the topology. A text box contains the instruction: "Klik na Note talat kako bi dodali zabilješke na topologiji." The interface includes a top menu bar with options like "New Cluster", "Move Object", "Set Tiled Background", and "Viewport". The bottom section features a "Power Cycle Devices" toolbar, a "Connections" panel, and a "Realtime" status window with a table for monitoring network events.

Fire	Last Status	Source	Destination

# Mrežni opis

The screenshot shows a network simulation software interface. The main workspace displays a topology diagram with the following components:

- Router:** 2620XM GAD, Fa0/0 192.168.1.1/24
- Switch:** 2950-24 Switch0
- PC:** PC-PT GAD\_Student, IP: 192.168.1.2/24, GW: 192.168.1.1
- Network:** 192.168.1.0/24

A 'Network Description' window is open, providing details about the topology:

**Network Description:**

This topology is the beginning of the larger topology we will build.

The router has a FastEthernet port that is addressed with the first available IP address in the 192.168.1.0/24 network.

The PC is connected to the network via a switch and has the next available IP address in the 192.168.1.0/24 network. It is configured to use the router's FastEthernet port as the Gateway.

A red box highlights the 'i' icon in the top right corner of the interface, with a red arrow pointing to it. A text box next to it reads: "Klik na 'i' ikonu kako bi upisali opis mrežne topologije."

The interface also includes a 'Logical' toolbar at the top, a 'Realtime' toolbar at the bottom right, and a 'Connections' panel at the bottom left.

# Snimanje mrežne topologije

The screenshot displays the Packet Tracer 4.1 interface. The main workspace shows a network diagram with a switch labeled '2950-24 Switch0' and a router labeled 'GAD'. The router's configuration window is open, showing the 'NVRAM' section with a 'Save' button. The 'File' menu is open, highlighting the 'Save' option. Two red callout boxes provide instructions: one points to the 'File... Save' menu item, and the other points to the 'NVRAM Save' button.

Snimanje topologije izborom polja **File... Save**

Kako bi snimili konfiguraciju na routeru klik na NVRAM **Save** dugme.

# Provjera veze

- Postoje dva načina za provjeru veze u PT.
- Prvi je u takozvanom realtime načinu rada, jednostavno otvarajući command prompt sa spojenog PC-a i koristeći komandu ping baš kao što bi to napravili sa pravom opremom.
- Drugi način je u simulacijskom načinu rada PT-a, kreiramo simulaciju koja nam omogućava otvaranje paketa u različitim točkama tijekom njegovog puta kako bi vidjeli kako je paket procesiran od strane uređaja kroz koji prolazi.

# Provjera u realtime načinu rada

U Realtime modu, izaberite Desktop opciju. Kliknite na Command Prompt ikonu kako bi otvorili command prompt na PC-u.

Packet Tracer 4.1 by Cisco Systems, Inc. (Alpha)

GAD\_Student

Physical | Config | Desktop

Logical [Root]

2620XM GAD Fa0/0 192.168.1.1

Network 192.168.1.0/24

2950-24 Switch0

PC-PT GAD\_Student

IP Configuration

Dial-up

Terminal

Command Prompt

Web Browser

PC Wireless

Power Cycle Devices

Connections

Scenario 0

New Delete

Toggle PDU List Window

Fire Last Status Source Destination

Realtime

# Ping na gateway

Packet Tracer 4.1 by Cisco Systems, Inc. (Alpha)

File Edit Options Help

Logical [Root]

2620XM GAD Fa0/0 192.168.1.1

1950-24 Switch0

Network 192.168.1.0/24

IP: 192.168.1.2 GW: 192.168.1.1

Command Prompt

```
Packet Tracer PC Command Line 1.0
PC>ping 192.168.1.1

Pinging 192.168.1.1 with 32 bytes of data:

Reply from 192.168.1.1: bytes=32 time=153ms TTL=120
Reply from 192.168.1.1: bytes=32 time=78ms TTL=120
Reply from 192.168.1.1: bytes=32 time=69ms TTL=120
Reply from 192.168.1.1: bytes=32 time=80ms TTL=120

Ping statistics for 192.168.1.1:
    Packets: Sent = 4, Received = 4, Lost = 0 (0% loss),
    Approximate round trip times in milli-seconds:
        Minimum = 69ms, Maximum = 153ms, Average = 95ms

PC>
```

Power Cycle Devices

Connections

Automatically Choose Connection Type

Scenario 0

New Delete

Toggle PDU List Window

Realtime

Fire	Last Status	Source	Destination
------	-------------	--------	-------------

Koristite komandu ping prema Gateway-u.

# Simulacijski način rada

The screenshot displays a network simulation software interface. The main window is titled "Logical [Root]" and shows a network diagram with three components: a 2620XM GAD router (Fa0/0 192.168.1.1/24), a 2950-24 Switch0, and a PC-PT GAD\_Student (IP: 192.168.1.2/24). A network 192.168.1.0/24 is also shown. The interface includes a top menu bar with options like "New Cluster", "Move Object", "Set Tiled Background", and "Viewport". On the right, there is an "Event List" table with columns for "Vis.", "Time (s)", "Last Device", "At Device", "Type", and "Info". Below the event list are "Reset Simulation" and "Constant Delay" (checked) buttons, and a "Captured to:" dropdown set to "(no captures)". The "Play Controls" section includes "Back", "Auto Capture / Play", and "Capture / Forward" buttons, along with a slider. A red box highlights the text "Prebacite u simulacijski način rada PT." (Switch to simulation mode PT.) with an arrow pointing to the "Simulation" button in the bottom right corner. The bottom status bar shows "Power Cycle Devices", "PLAY CONTROLS:", "Back", "Auto Capture / Play", "Capture / Forward", "Event List", and "Simulation". The bottom left has a "Connections" panel, and the bottom right has a "Scenario 0" dropdown, "New", "Delete", and "Toggle PDU List Window" buttons, along with a table with columns "Fire", "Last Status", "Source", and "Destination".

Prebacite u simulacijski način rada PT.

## Što je simulacijski način rada PT-a

- Realtime način rada PT-a radi na način da se sve izvršava u stvarnom vremenu baš kao i kod realnih uređaja.
- Simulacijski način rada PT-a se koristi za analizu prometa tijekom njegovog puta kroz mrežu na bilo kojoj točki gdje se radi obrada paketa. (paket sniffer)

# Kreiranje PDU paketa

3. Izaberi odredište paketa.

2. Izaberi izvoriste paketa.

1. Klikni na Simple PDU ikonu.

Logical [Root] New Cluster Move Object Set Tiled Background Viewport

Event List

Vis.	Time (s)	Last Device	At Device	Type	Info
<input checked="" type="checkbox"/>	0.000	--	--	GAD_Student ICMP	

Reset Simulation  Constant Delay Captured to: 0.000 s

Play Controls

Back Auto Capture / Play Capture / Forward

Event List Filters

Visible Events: ARP, CDP, DHCP, EIGRP, ICMP, RIP, TCP, UDP, VTP, STP, OSPF, DTP, TELNET, TFTP, HTTP, DNS

Edit Filters Show All

Simulation

Fire	Last Status	Source	Destinat
<input checked="" type="checkbox"/>	In Progress	GAD_Student	GAD

Connections

Scenario 0

New Delete

Toggle PDU List Window

Automatically Choose Connection Type

# Praćenje paketa i događaja

Event List prozor snima (ili "captures") sve što se događa sa PDU paketom koji se propagira kroz mrežu.

Event List Filters može filtrirati točno određeni promet kroz mrežu.

PDU List pokazuje sve informacije vezane za PDU.

The screenshot displays a network simulation environment. On the left, a network diagram shows a central switch labeled '2951-24 Switch0' connected to a host labeled 'GAD\_Student'. The main interface features several panels:

- Event List:** A table with columns 'Vis.', 'Time (s)', 'Last Device', 'At Device', 'Type', and 'Info'. It contains one entry: an eye icon, '0.000', '--', 'GAD\_Student', 'ICMP', and a blue square.
- Event List Filters:** A section with a 'Visible Events' list including ARP, CDP, DHCP, EIGRP, ICMP, RIP, TCP, UDP, VTP, STP, OSPF, DTP, TELNET, TFTP, HTTP, and DNS. It includes 'Edit Filters' and 'Show All' buttons.
- Simulation Panel:** Located at the bottom right, it includes a 'Scenario 0' dropdown, 'New' and 'Delete' buttons, and a 'Toggle PDU List Window' button. Below these is a table with columns 'Fire', 'Last Status', 'Source', and 'Destinat'. It shows one entry: a red fire icon, 'In Progress', 'GAD\_Student', and 'GAD'.

Red arrows point from the text boxes to the corresponding elements in the software interface.

# Pokretanje simulacije

The screenshot displays a network simulation environment. On the left, a network diagram shows a router connected to a switch labeled '2950-24 Switch0', which is in turn connected to a PC labeled 'PC-PT GAD\_Student'. A red-bordered text box with a red arrow pointing to the 'Auto Capture / Play' button contains the instruction: 'Klikni na **Auto Capture/Play** dugme za početak simulacije.'

The main interface features a yellow header bar with the title 'Logical [Root]' and several menu items: 'New Cluster', 'Move Object', 'Set Tiled Background', and 'Viewport'. Below the header, the 'Event List' window is open, showing a table with the following data:

Vis.	Time (s)	Last Device	At Device	Type	Info
<input checked="" type="checkbox"/>	0.000	--	GAD_Student	ICMP	

Below the event list, there are controls for 'Reset Simulation' (with a checked checkbox), 'Constant Delay', and 'Captured to: \* 0.000 s'. The 'Play Controls' section includes buttons for 'Back', 'Auto Capture / Play', and 'Capture / Forward', along with a progress slider. The 'Event List Filters' section lists 'Visible Events: ARP, CDP, DHCP, EIGRP, ICMP, RIP, TCP, UDP, VTP, STP, OSPF, DTP, TELNET, TFTP, HTTP, DNS' and includes 'Edit Filters' and 'Show All' buttons.

The bottom of the interface has a yellow bar with 'Power Cycle Devices' and 'PLAY CONTROLS: Back Auto Capture / Play Capture / Forward'. Below this are various toolbars, including 'Connections', a toolbar with icons for power, zoom, and selection, and a 'Simulation' window showing 'Scenario 0' with 'New' and 'Delete' buttons, and a 'Toggle PDU List Window' button. The 'Simulation' window also displays a table with columns 'Fire', 'Last Status', 'Source', and 'Destinat':

Fire	Last Status	Source	Destinat
<input checked="" type="checkbox"/>	In Progress	GAD_Student	GAD

# Provjera veze u simulacijskom načinu

Kako simulacija traje, svi događaji se bilježe na Event List. Ovi događaji pokazuju stanje paketa na svakom koraku duž cijelog puta kroz mrežu.

The screenshot displays a network simulation environment. On the left, a network diagram shows a '2950-24 Switch0' connected to a 'PC-PT GAD\_Student'. A red arrow points from the text box to the PC icon, which has a green checkmark. The 'Event List' window is open, showing a table of events. A red arrow points from the text box to the first row of the table. Below the table, there are 'Reset Simulation' and 'Constant Delay' checkboxes, and a 'Captured to: 0.004 s' field. The 'Play Controls' section includes 'Back', 'Auto Capture / Play', and 'Capture / Forward' buttons. At the bottom, there are 'Edit Filters' and 'Show All' buttons. The bottom status bar shows 'Power Cycle Devices', 'PLAY CONTROLS:', 'Scenario 0', and 'Simulation'.

Vis.	Time (s)	Last Device	At Device	Type	Info
	0.000	--	GAD_Student	ICMP	
	0.001	GAD_Student	Switch0	ICMP	
	0.002	Switch0	GAD	ICMP	
	0.003	GAD	Switch0	ICMP	
👁	0.004	Switch0	GAD_Student	ICMP	

Uspješna ping naredba će se prepoznati po zelenom polju.

# PDU informacije

**PDU Information at Device: GAD**

OSI Model | Inbound PDU Details | Outbound PDU Details

At Device: GAD  
Source: GAD\_Student  
Destination: GAD

In Layers	Out Layers
Layer7	Layer7
Layer6	Layer6
Layer5	Layer5
Layer4	Layer4
Layer 3: IP Header Src. IP: 192.168.1.2, Dest. IP: 192.168.1.1	Layer 3: IP Header Src. IP: 192.168.1.1, Dest. IP: 192.168.1.2
Layer 2: Ethernet II Header 00E0.B043.9EE8 >> 0007.EC69.76D3	Layer 2: Ethernet II Header 0007.EC69.76D3 >> 00E0.B043.9EE8
Layer 1: Port FastEthernet0/0	Layer 1: Port(s): FastEthernet0/0

1. FastEthernet0/0 receives the frame.

Challenge Me << Previous Layer Next Layer >>

**Event List**

Vis.	Time (s)	Last Device	At Device	Type	Inf
	0.000	--	GAD_Student	ICMP	
	0.001	GAD_Student	Switch0	ICMP	
	0.002	Switch0	GAD	ICMP	
	0.003	GAD	Switch0	ICMP	
	0.004	Switch0	GAD_Student	ICMP	

Reset Simulation  Constant Delay Captured to: \* 0.004 s

**Simulation**

Fire	Last Status	Source	Destinat
	Successful	GAD_Student	GAD

# Napredno korištenje PT-a

- Activity Wizard

Mogućnost PT-a kojom instruktor može studentima kreirati zadatke (npr. skill) na način da obrada rezultat bude automatska i da student od programa odmah dobije odgovor o učinjenom radu i svim pogreškama.

# Activity Wizard

## Osnovne komponente:

- **Answer network:** Riješeni zadatak!

Mreža koju studenti moraju dobiti nakon što riješe postavljeni zadatak.

- **Initial network:** Zadatak!

Mreža koju studenti inicijalno dobiju kao zadatak i koji na osnovu uputa trebaju riješiti kako bi dobili na kraju *answer network* mrežu.

# Što sve može biti zadatak?

Tehnologije:

- IP
- Physical
- Routing
- Switching
- ACLs
- NAT

The screenshot shows a web-based assessment tool interface. At the top, there are tabs for "Assessment Options", "Timing", "Connectivity Test", and "Overall Feedback". Below the tabs, a message states: "Use the tree below to select the components you want to assess. You may also use the View Filter to show only certain categories." A "View Filter" section contains several checkboxes: IP, Physical, Variables (with a green dot), Routing, Switching, ACL, NAT, and View/Hide All. The main area is titled "Assessment Items" and contains a tree view for a device named "Houston". The tree is expanded to show various configuration items, many of which are checked or have a green dot. The items include: Network (checked), Ext. Web Server (unchecked), Houston (checked), ACL (unchecked), Banner MOTD (unchecked), Boot System Files (unchecked), CDP (unchecked), Clock Timezone (unchecked), Config-Register: 8450 (checked with green dot), Console (unchecked), Console Line (unchecked), DHCP Server (unchecked), DNS (unchecked), EIGRP (unchecked), Enable Password (unchecked), Enable Secret (unchecked), Flash Files (unchecked), Host Name: Router (checked with green dot), NAT (unchecked), OSPF (unchecked), and Ports (checked).

## Planiranje zadatka

- Najlakši način je prvo kreirati answer mrežu.
- Pomicanjem i mijenjanjem različitih elemenata mreže možemo dobiti inicijalnu mrežu.

**ili....**

- Napravite import .pkt datoteke koji već sadrži sve ili gotovo sve elemente koje želite imati u testu.

# Activity Wizard

Opcija **Activity Wizard** se pokreće preko File menija ili jednostavno kombinacijom tipki **Ctrl+W**.

Fire	Last Status	Source	Destination	Type	Color	Time (sec)	Period
●	--	PC3	Server1	ICMP	Red	0.000	N
●	--	PC4	20.20.20.2	ICMP	Purple	1.000	N

# Početak podešavanja (Welcome Screen)

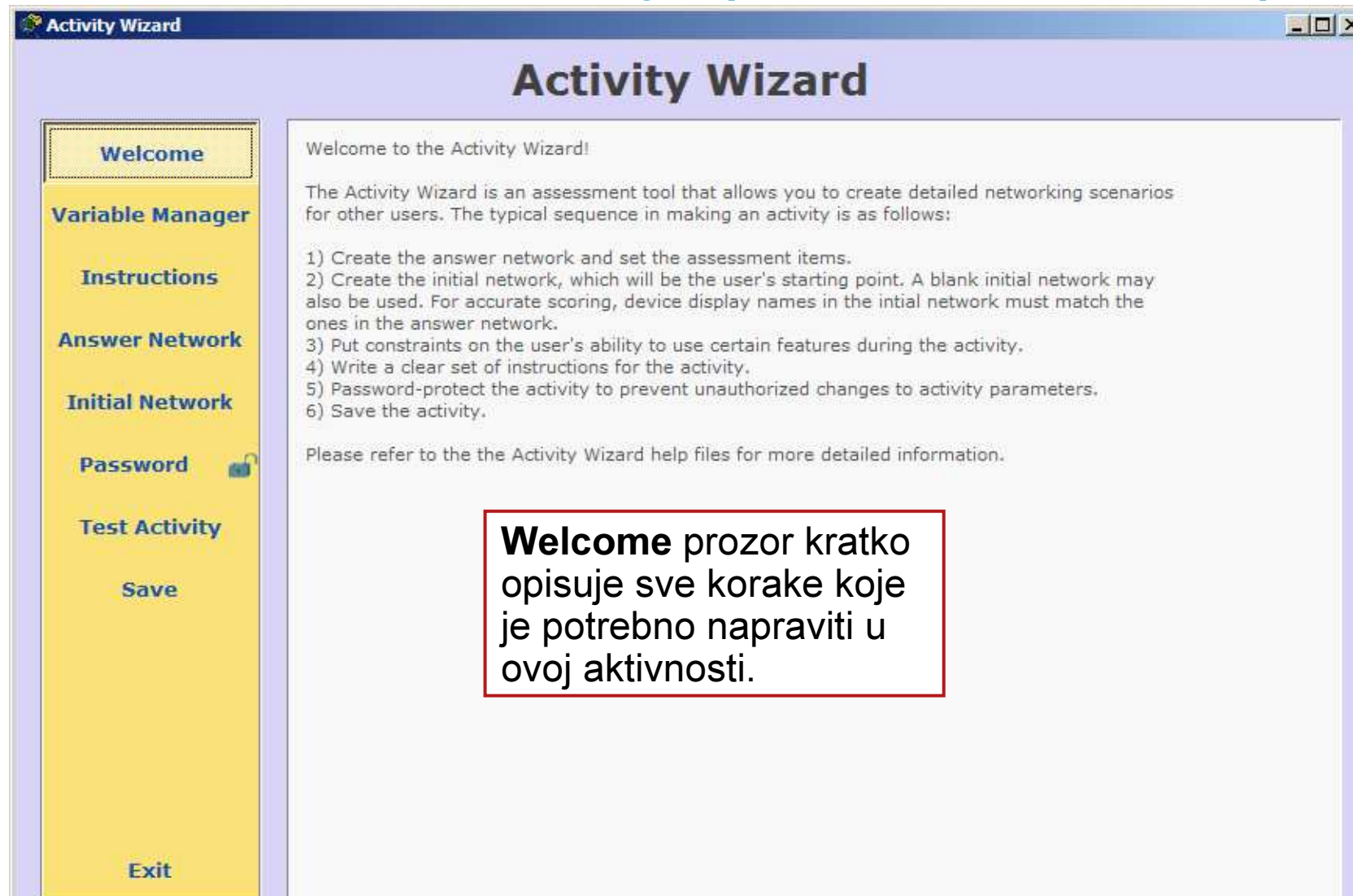

# Activity Wizard studentski pogled

The screenshot displays a network simulation software interface. On the left, a logical network diagram is shown with a red border. It includes a PC/PT Ext. Web Server connected to a 2621XM ISP router, which is connected to a 2621XM Houston router. The Houston router is connected to a 2950-24 SWS3 switch, which is connected to three other switches. The activity wizard window on the right is titled "PT Activity: 00:09:30" and contains the following instructions:

1. Assign IP addresses and enable the interfaces as follows:

Device	Interface	IP address	Mask
ISP	S 0/0	100.10.10.2	255.255.0.0
ISP	FaE 0/0	20.20.20.1	255.255.0.0
Houston	S 0/1	100.10.10.1	255.255.0.0
Houston	FaE 0/0	192.168.1.97	255.255.255.224
Houston	FaE 0/1	192.168.1.33	255.255.255.224

2. Test connectivity between all devices. You should be able to ping from each end node to all other end nodes.
3. An extended access-list HFW1 has already been created on the Houston router. The goals of the access-list are to permit PC 3 to access Server 1 and to block all other hosts from accessing the

At the bottom of the wizard window, it shows "Time Elapsed: 00:09:30" and "Completion: 0%". There are buttons for "Check Results" and "Reset Activity".

The interface also shows a "Power Cycle Devices" section with a "Routers" category containing icons for 1841, 2620XM, 2621XM, 2811, and Generic routers. A "Realtime" section at the bottom right shows a table with columns for "Fire", "Last Status", "Source", "Destination", and "Type".

Fire	Last Status	Source	Destination	Type
●	--	PC3	Server1	ICM
●	--	PC4	20.20.20.2	ICM

# Activity Wizard rezultati

File Options Help

## Activity Results

Time Left: 00:13:23

You did not complete the activity. Please close this window and try again.

Assessment Items	Status
Serial0/0	
IP Address	Correct
Subnet Mask	Correct
RIP	
Networks	
192.168.2.0	Correct
192.168.3.0	Correct
GAD	
Ports	
FastEthernet0/0	
IP Address	Correct
Subnet Mask	Correct
Serial0/0	
IP Address	Correct
Subnet Mask	Correct
RIP	
Networks	
192.168.1.0	Correct
192.168.2.0	Correct
HostA	
Default Gateway	Incorrect
Ports	
FastEthernet	
IP Address	Incorrect
Subnet Mask	Incorrect
HostB	
Default Gateway	Incorrect
Ports	
FastEthernet	
IP Address	Incorrect

Completed Components : 12  
Required Components : 18

Component Types:

IP	: 8/14
Routing	: 4/4
ACL	: 0/0
NAT	: 0/0
Physical	: 0/0
Switching	: 0/0
Others	: 0/0

Kada student završi i klikne na polje **Check Results**, može vidjeti sve što je u ispitu pogriješio ili što još nije završio, kao i ukupne rezultate samo ispita.

## Prednosti korištenja PT-a - INSTRUKTORI

- Mogućnost podučavanja kompleksnijih mrežnih koncepta CCNA nivoa

Mogućnost demonstracije tehnologije i konfiguracija

Mogućnost povratne informacije od studenata kroz Activity Wizard sa momentalnim odgovorima na riješene zadatke

- Dodatak, nadomjestak mrežnoj opremi u laboratoriju

Mogućnost prezentacije stvari koje zbog nedostatka mrežne opreme instruktori nisu u stanju pokazati

Mogućnost da studenti uče i vježbaju i van laboratorija

Razvijanje sposobnosti timskog rada korištenjem multiuser opcija PT-a

# Prednosti korištenja PT-a - STUDENTI

- Besplatan alat za vježbanje, konfiguriranje mrežnih protokola
  - Mogućnost izrade vlastitih mrežnih topologija i vježbanja na njima
  - Promatranje virtualnih paketa u prolazu kroz mrežu i njihovo proučavanje
- Mogućnost vježbanja van laboratorija
  - Mogućnost vježbanja u vrijeme kada student želi i odakle mu odgovara
  - Mogućnost kreiranja složenijih i kompleksnijih topologija nego to dostupna mrežna oprema u laboratoriju dozvoljava

## Prednosti PT-a – ZAKLJUČAK

- Učenje čini lakšim pružajući multikorisničko okruženje instruktorima u kojem jednostavno mogu podučavati kompleksne mrežne tehnologije.
- Pruža vrlo realistično okruženje za simulacije, vizualizacije, istraživanja i eksperimentiranja sa mrežnim protokolima.
- Instruktori i studenti mogu kreirati vlastiti virtualni "mrežni svijet" u kojem mogu jednostavno učiti na vrlo realističnim primjerima.



Pitanja?



[camt@carnet.hr](mailto:camt@carnet.hr)