

Evoluce bezdrátových sítí poskytovatelů služeb

SP4/L2

Martin Kramoliš, CCIE #4738

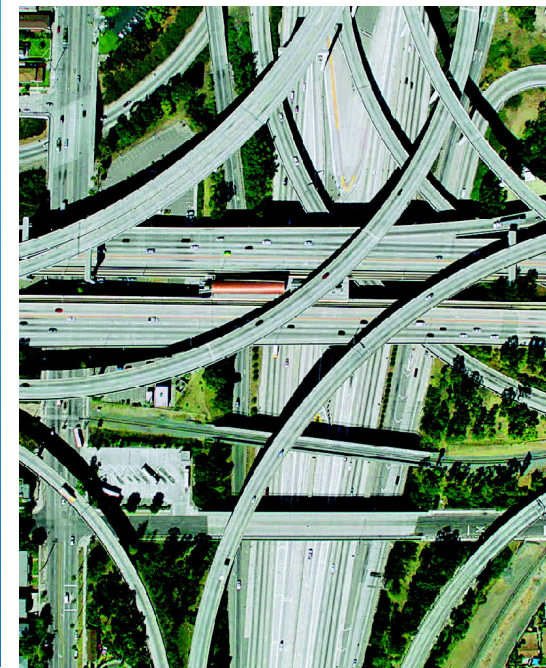
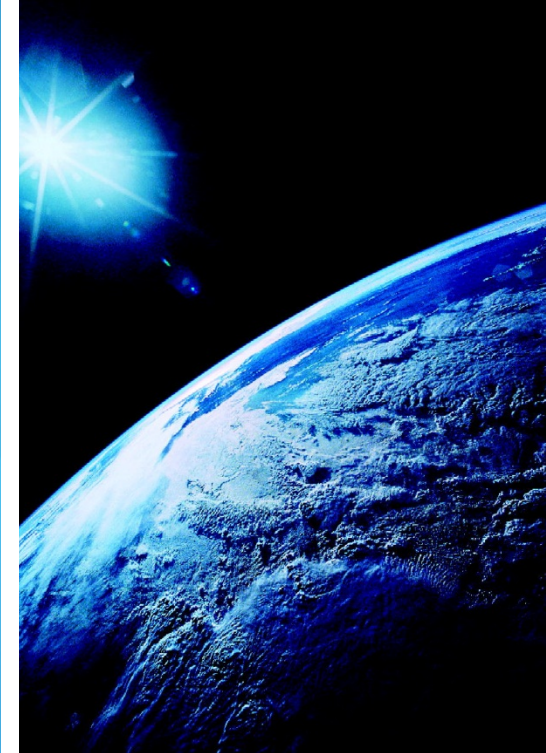

Agenda



From 2G to 3G

Introducing LTE

Femtocells

WLAN standards update

Improving Wi-Fi User Experience

Interfacing Wi-Fi with Mobile

Network Discovery and Selection for Mobile

Future Outlook and Summary

In the beginning.....

- There was wireless ISDN (aka GSM)

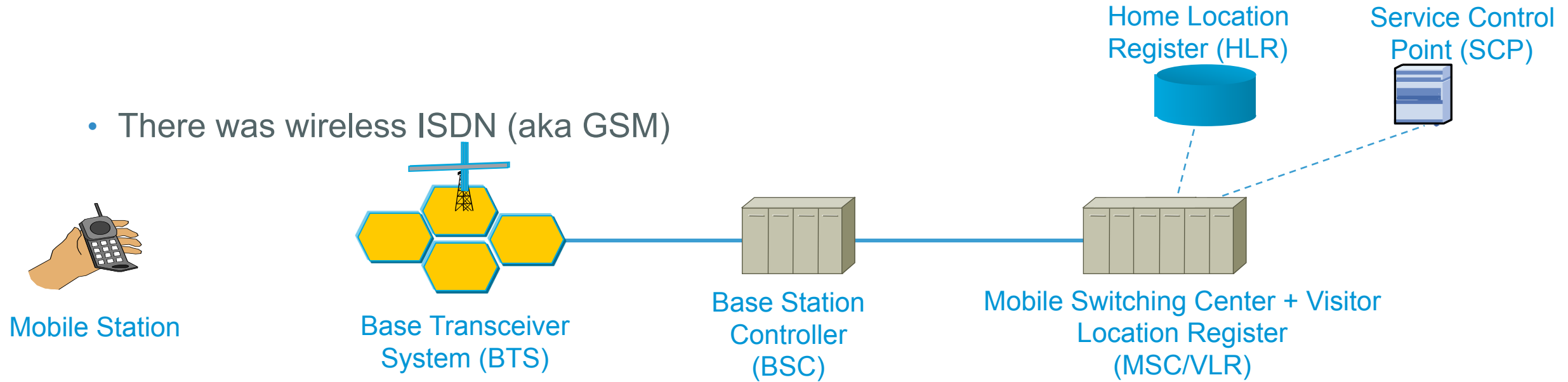

- Voice oriented architecture
- Re-define fixed wireline services (e.g. SS and IN)
- SMS is a signalling transport rather than a data service
- Network transport based on TDM

... data was circuit switched

- One burst every TDMA frame was sufficient to transport a speech frame with source rate of 13 kbit/s
- GSM Phase 2 (circa 1996) added Circuit Switched Data support offering 9.6 kbit/s service
- High Speed CSD consisted in aggregating multiple timeslot for a single user but resource intensive

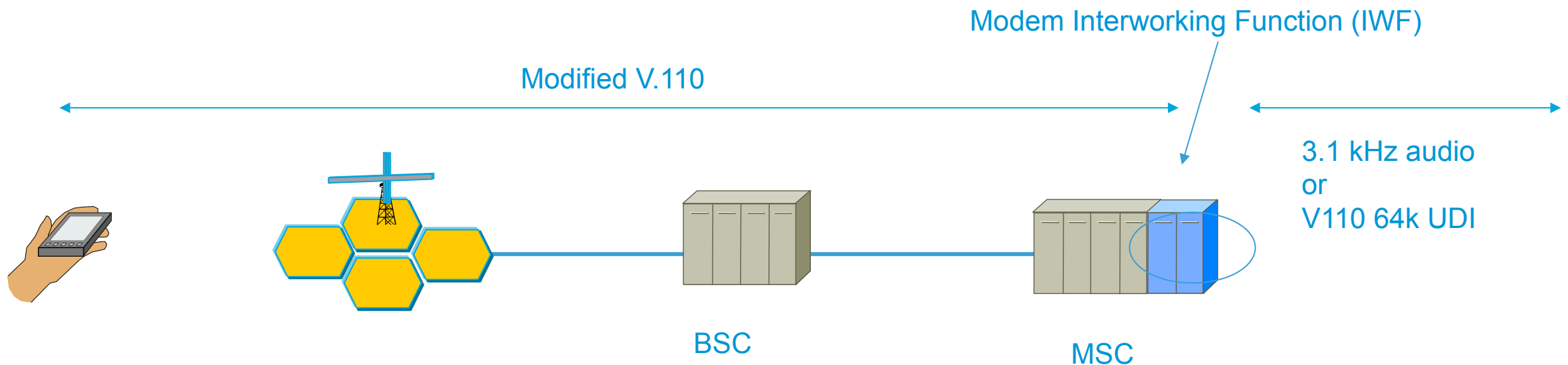

.. and eventually packet data with General Packet Radio System was bolted on

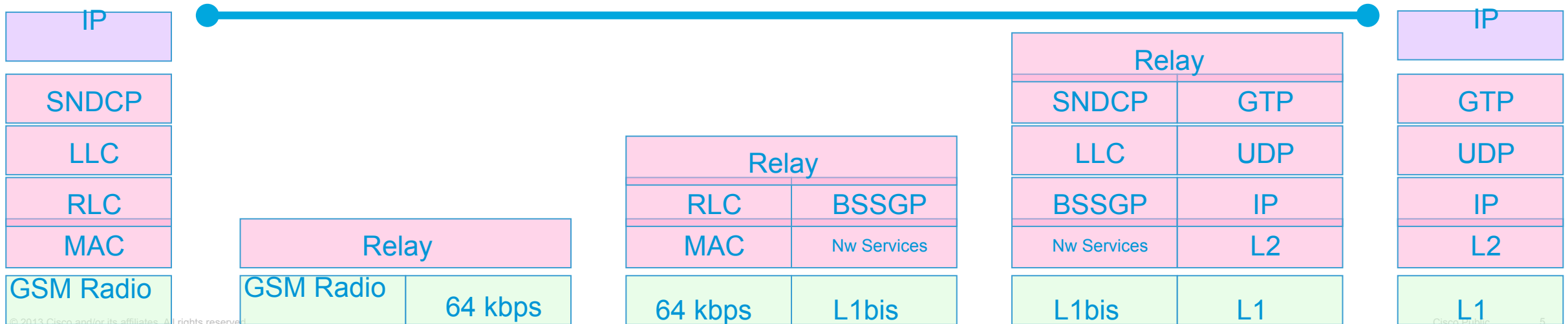
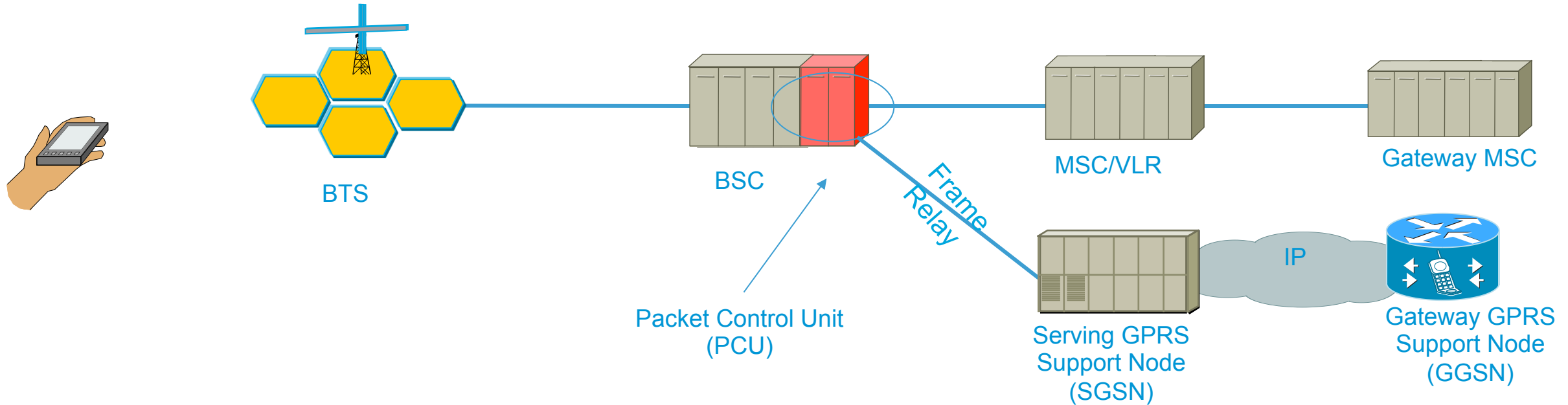

Home Based GGSN Roaming

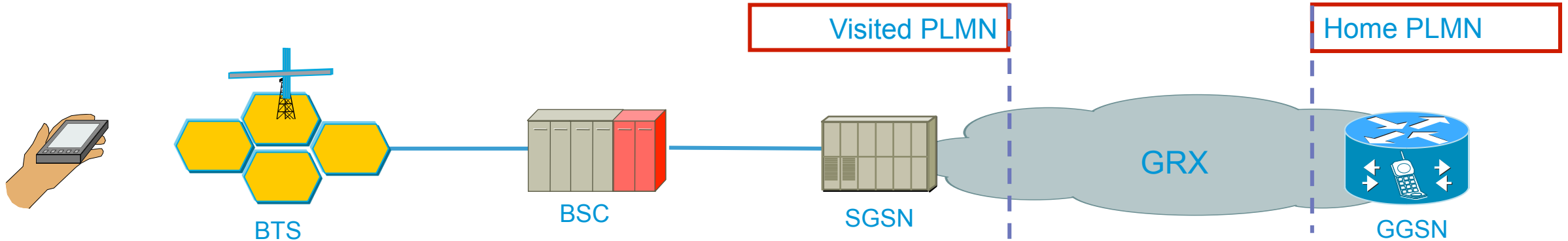

- GPRS Roaming Exchange (GRX)
- GRX Services (as per GSMA IR.34)
 - DNS routing (for APN translation)
 - IP transport including routing & QoS
 - Security
- In future release, GRX is enhanced to become IPX (IP exchange) and supports application proxy capabilities (e.g. for SIP), charging, etc.

3GPP UMTS System

- First step towards an all IP network
- New radio designed to accommodate greater packet throughput (up to 2Mbits/s initially... In reality, can support up to 384 kbit/s)
- Core network remains largely unchanged from 2.5G
- Migration to ATM for Radio Access Transport
- More control into the RNC

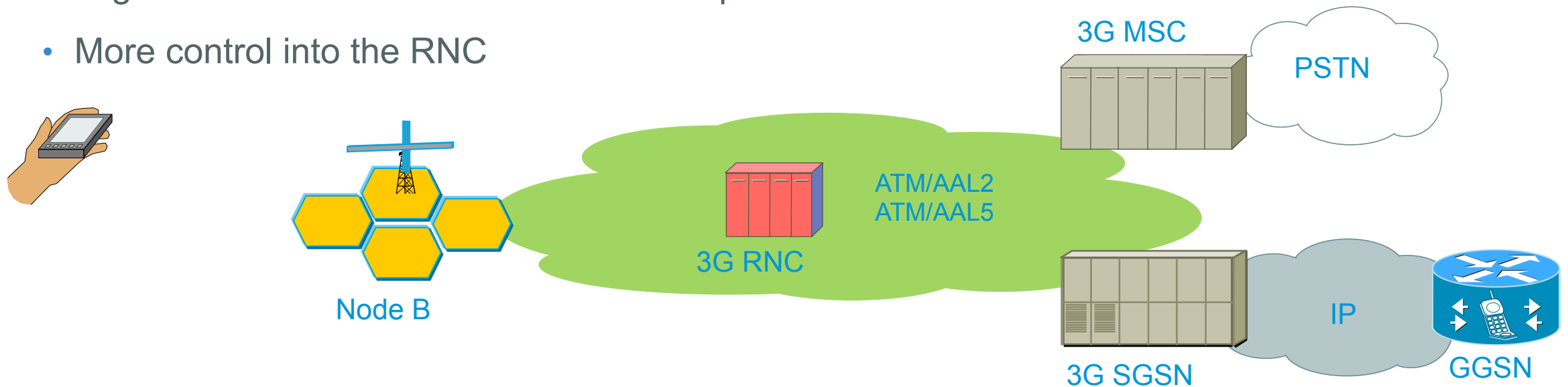

3G Packet Architecture

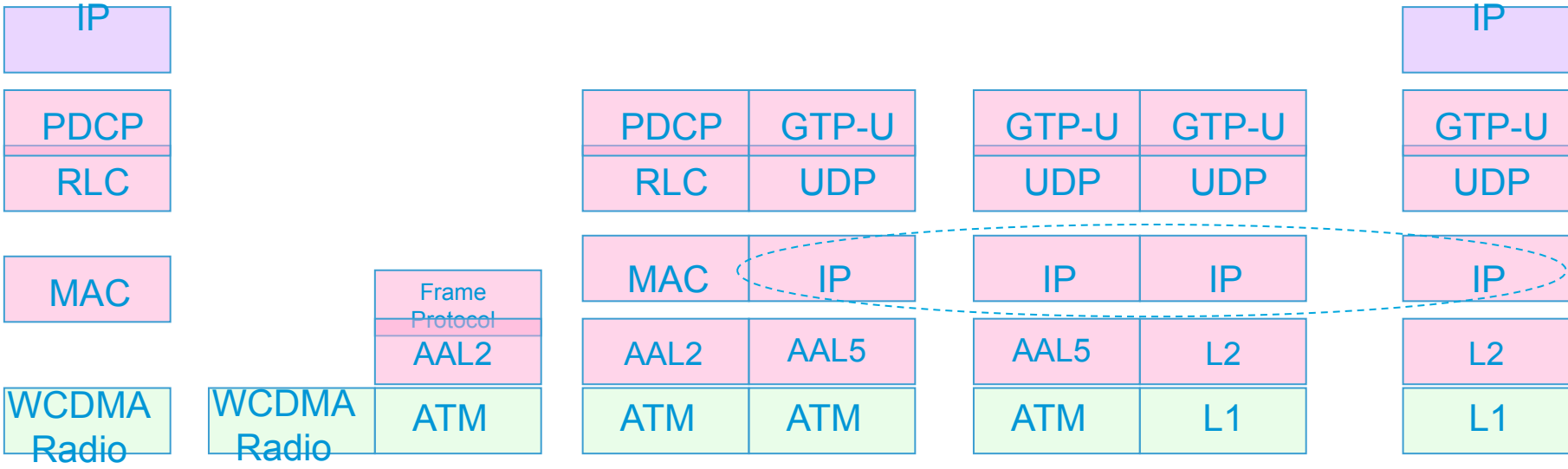
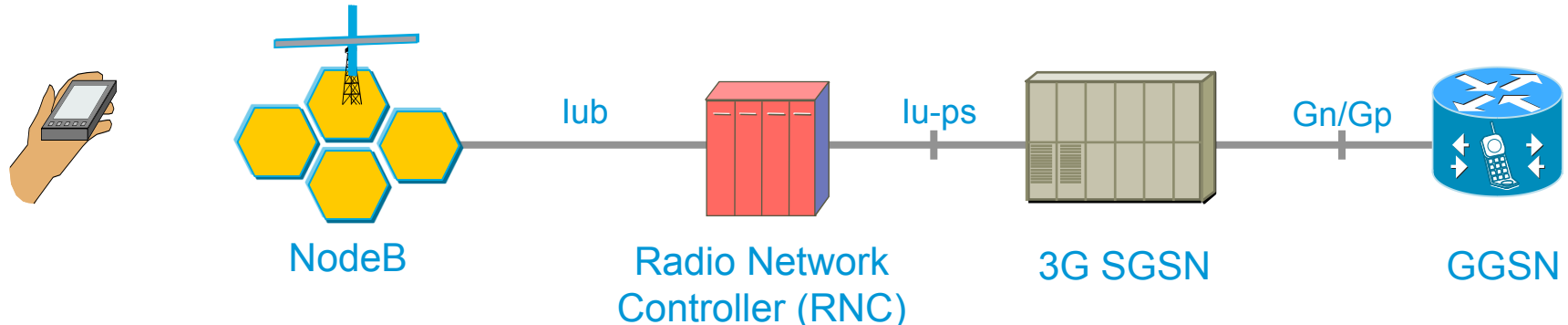

3GPP R4 Voice Services

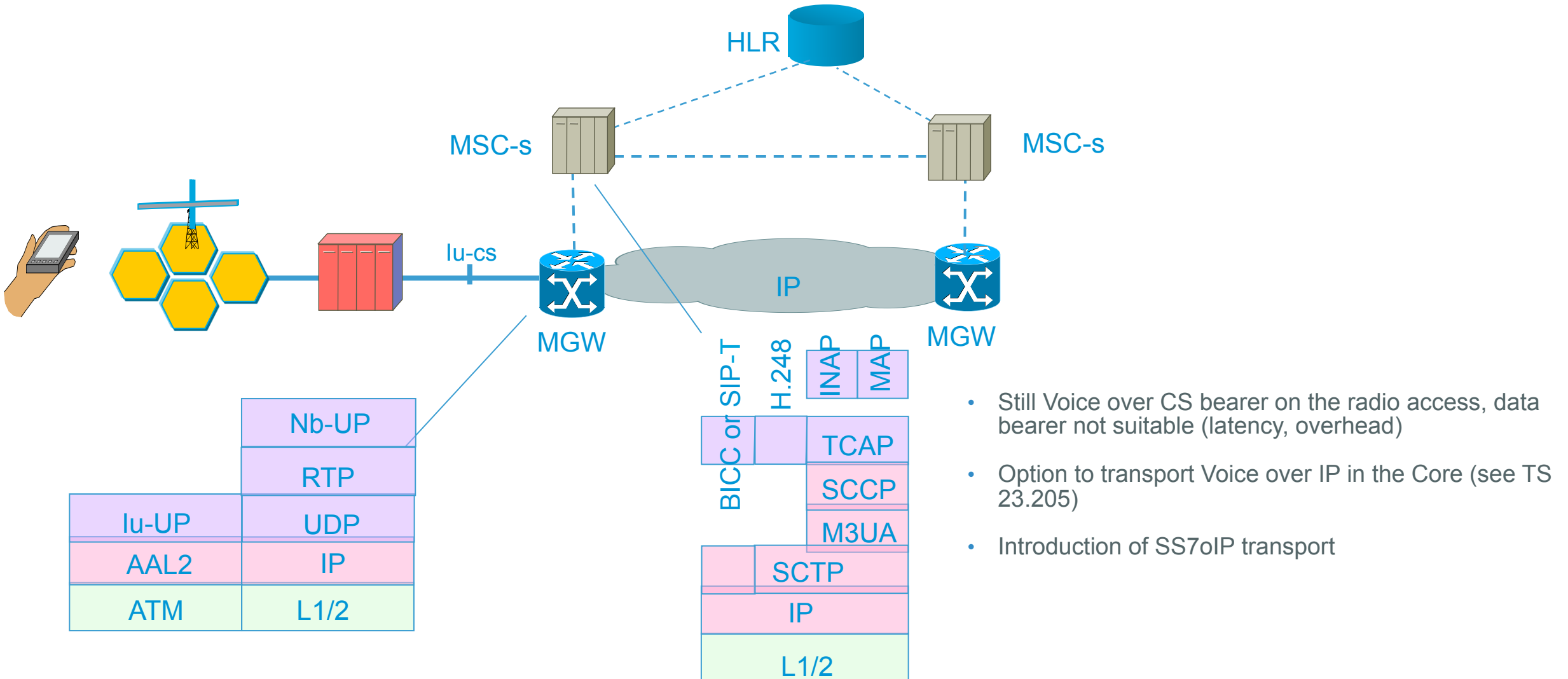

Evolution to 3.5G (UMTS/HSDPA/HSPA/HSPA+)

3GPP Rel.	Modulation [DL/UL]	MIMO	Channel [MHz]	Carrier #	Downlink [Mbps]	Uplink [Mbps]
99	QPSK/QPSK	-	5/5	1	0.375	0.375
5	QAM16/QPSK	-	5/5	1	14.4	0.375
6	QAM16/QAM16	-	5/5	1	14.4	5.76
7	QAM64/QAM16	-	5/5	1	21.1	11.5
7	QAM16/QAM16	2x2	5/5	1	28.0	11.5
8	QAM64/QAM16	2x2	5/5	1	42.2	11.5
8	QAM64/QAM16	-	10/5	2DL	42.2	11.5
9	QAM64/QAM16	2x2	10/10	2DL/2UL	84	23
10	QAM64/QAM16	2x2	20/10	4DL/2UL	168	23
11	QAM64/QAM16	2x2 DL/UL	40/10	8DL/2UL	336	69

UMTS
HSDPA
HSPA
HSPA+

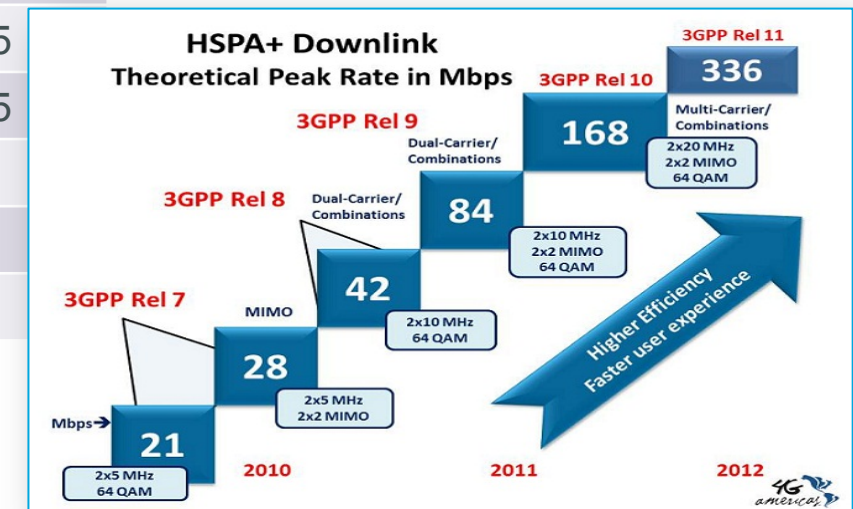

Source: 4G Americas

Converged RAN Aggregation

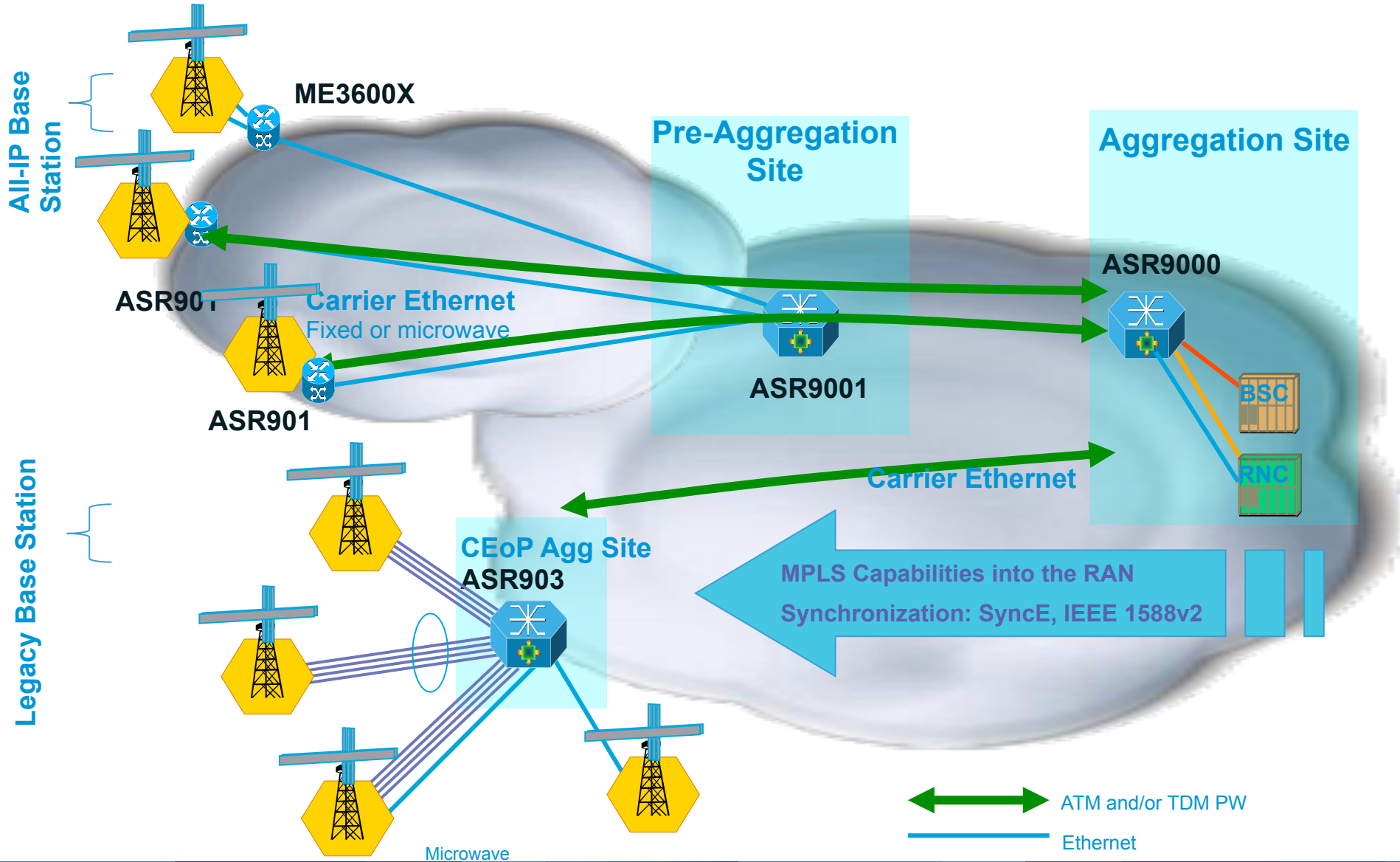

3G architecture summary

- Highlighting the growing importance of IP transport

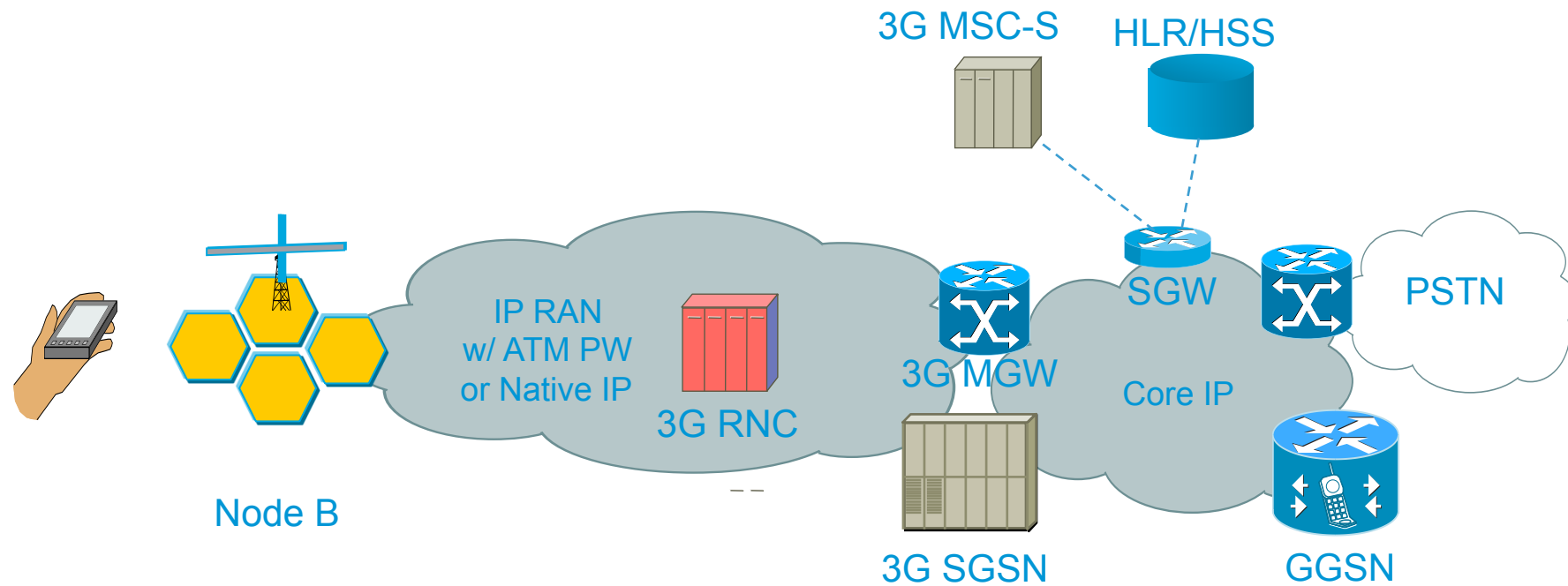

Agenda



From 2G to 3G

Introducing LTE

Femtocells

WLAN standards update

Improving Wi-Fi User Experience

Interfacing Wi-Fi with Mobile

Network Discovery and Selection for Mobile

Future Outlook and Summary

What is LTE/R8?

- LTE is NOT 4G (yet)
- 4G will be a set of requirements defined by ITU for *IMT Advanced* systems – 1Gbps to low mobility, 100 Mbps to highly mobile users
- 4x4 LTE estimated to provide 300 Mbps

◆ **Recommendation ITU-R M.1645**
Framework and overall objectives for the future development of IMT-2000 and systems beyond IMT-2000

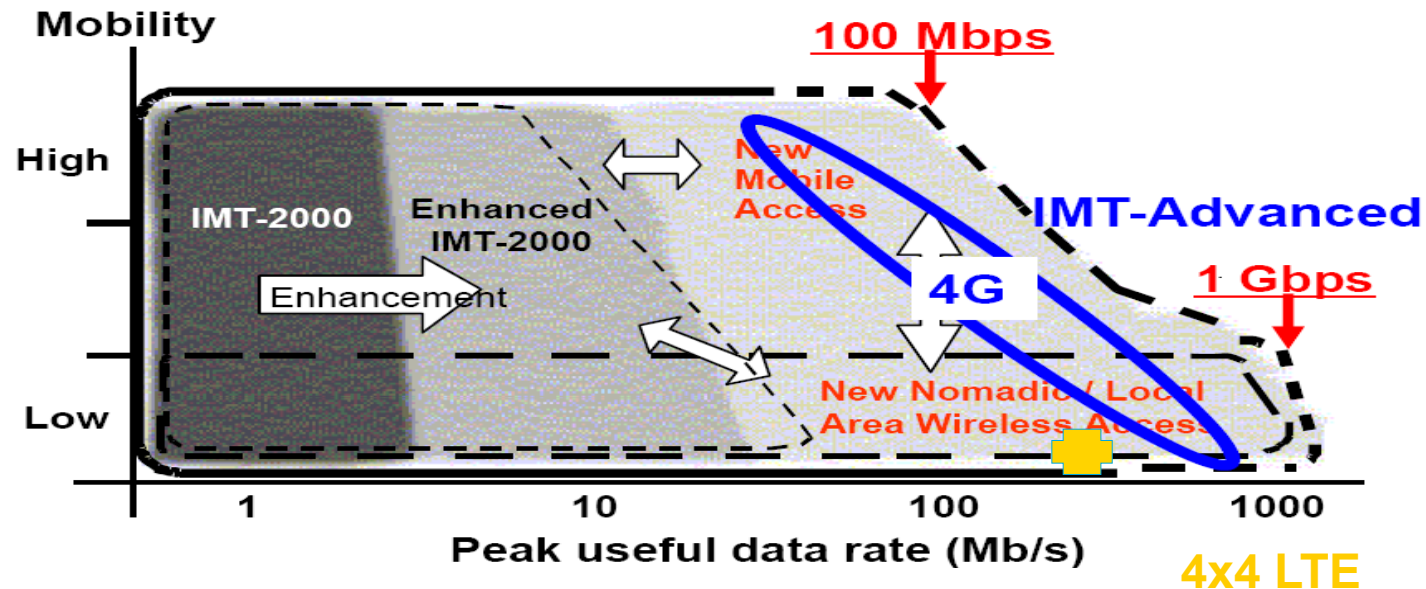

E-UTRAN Highlights



- New Radio access introduced in 3GPP Rel 8
Minor improvements in Rel 9 and Rel 10
- Significantly increased data throughput
3-4 times greater than HSDPA, target 2-3 times greater than HSUPA
- High Spectral Efficiency
OFDMA in DL for multipath protection
SC-FDMA in UL for low PAPR
Multi-Antenna support (MIMO)
Variable modulations
- Very low latency
Short setup time & transfer
Short HO latency and interruption
- Scalable Bandwidth support
1.4, 3, 5, 10, 15 and 20 MHz

Category		1	2	3	4	5
Peak rate Mbps	DL	10	50	100	150	300
	UL	5	25	50	50	75
Capability for physical functionalities						
RF bandwidth		20MHz				
Modulation	DL	QPSK, 16QAM, 64QAM				
	UL	QPSK, 16QAM				QPSK, 16QAM, 64QAM
Multi-antenna						
2 Rx diversity		Assumed in performance requirements.				
2x2 MIMO		Not supported	Mandatory			
4x4 MIMO		Not supported				Mandatory

Majority of devices

LTE Frequency Bands

E-UTRA Operating Band	Uplink (UL) operating band	Downlink (DL) operating band	Duplex Mode
	BS receive UE transmit	BS transmit UE receive	
	$F_{UL_low} - F_{UL_high}$	$F_{DL_low} - F_{DL_high}$	
1	1920 MHz – 1980 MHz	2110 MHz – 2170 MHz	FDD
2	1850 MHz – 1910 MHz	1930 MHz – 1990 MHz	FDD
3	1710 MHz – 1785 MHz	1805 MHz – 1880 MHz	FDD
4	1710 MHz – 1755 MHz	2110 MHz – 2155 MHz	FDD
5	824 MHz – 849 MHz	869 MHz – 894MHz	FDD
6	830 MHz – 840 MHz	875 MHz – 885 MHz	FDD
7	2500 MHz – 2570 MHz	2620 MHz – 2690 MHz	FDD
8	880 MHz – 915 MHz	925 MHz – 960 MHz	FDD
9	1749.9 MHz – 1784.9 MHz	1844.9 MHz – 1879.9 MHz	FDD
10	1710 MHz – 1770 MHz	2110 MHz – 2170 MHz	FDD
11	1427.9 MHz – 1447.9 MHz	1475.9 MHz – 1495.9 MHz	FDD
12	699 MHz – 716 MHz	729 MHz – 746 MHz	FDD
13	777 MHz – 787 MHz	746 MHz – 756 MHz	FDD
14	788 MHz – 798 MHz	758 MHz – 768 MHz	FDD
17	704 MHz – 716 MHz	734 MHz – 746 MHz	FDD

E-UTRA Operating Band	Uplink (UL) operating band	Downlink (DL) operating band	Duplex Mode
	BS receive UE transmit	BS transmit UE receive	
	$F_{UL_low} - F_{UL_high}$	$F_{DL_low} - F_{DL_high}$	
33	1900 MHz – 1920 MHz	1900 MHz – 1920 MHz	TDD
34	2010 MHz – 2025 MHz	2010 MHz – 2025 MHz	TDD
35	1850 MHz – 1910 MHz	1850 MHz – 1910 MHz	TDD
36	1930 MHz – 1990 MHz	1930 MHz – 1990 MHz	TDD
37	1910 MHz – 1930 MHz	1910 MHz – 1930 MHz	TDD
38	2570 MHz – 2620 MHz	2570 MHz – 2620 MHz	TDD
39	1880 MHz – 1920 MHz	1880 MHz – 1920 MHz	TDD
40	2300 MHz – 2400 MHz	2300 MHz – 2400 MHz	TDD

~ 40 LTE Bands Worldwide!

Reference: 3GPP TS36.101 (Rel. 8)

LTE/EPS Architecture

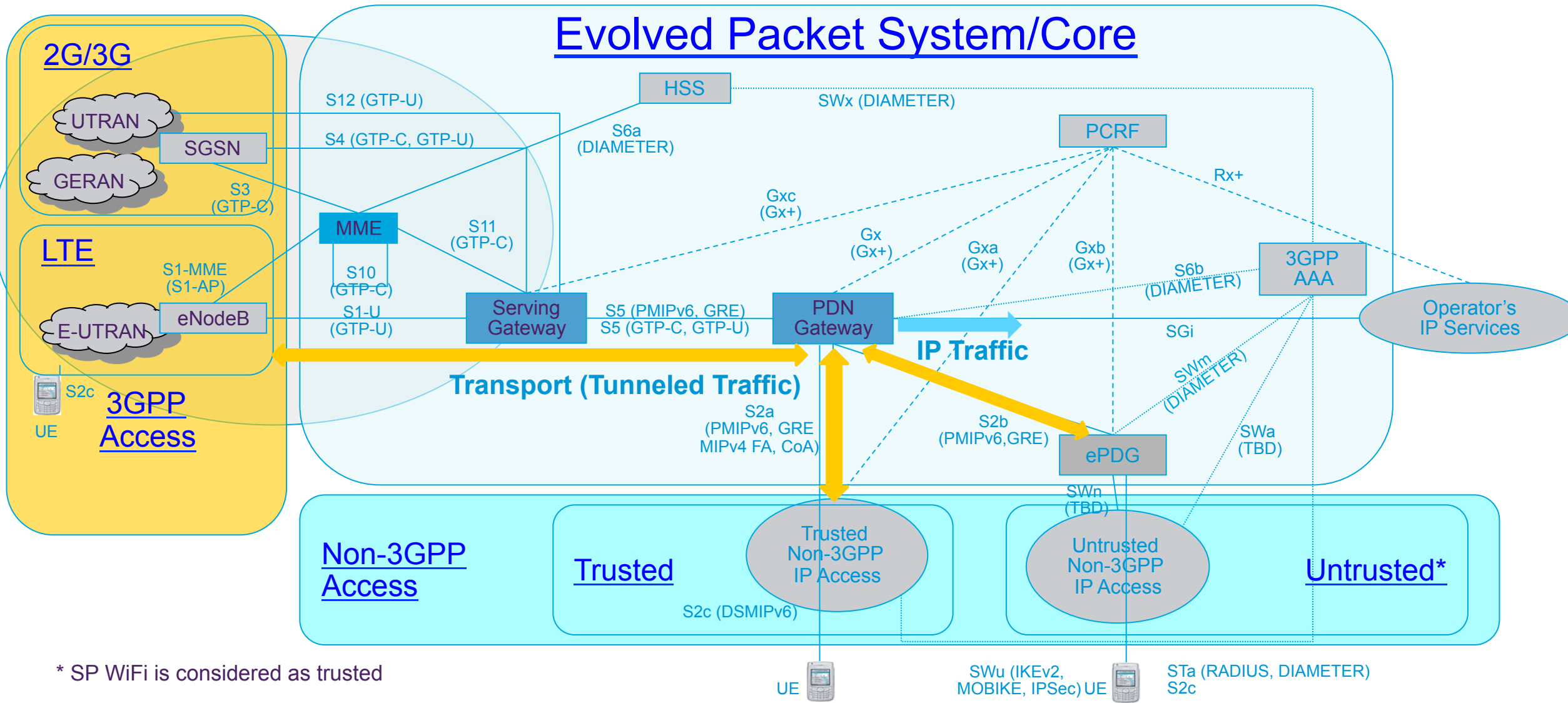

* SP WiFi is considered as trusted

LTE/SAE System Components

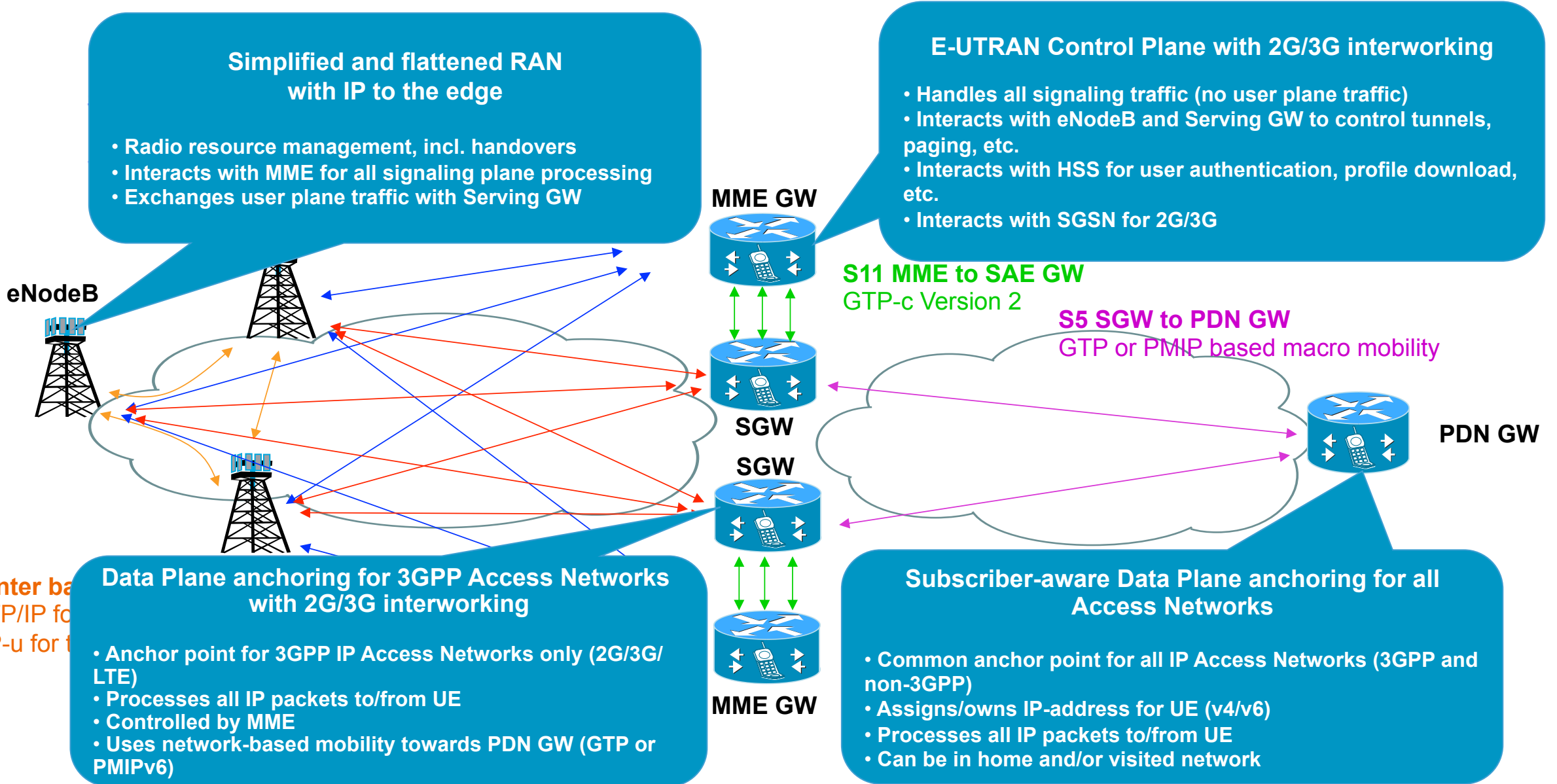

Simplified and flattened RAN with IP to the edge

- Radio resource management, incl. handovers
- Interacts with MME for all signaling plane processing
- Exchanges user plane traffic with Serving GW

E-UTRAN Control Plane with 2G/3G interworking

- Handles all signaling traffic (no user plane traffic)
- Interacts with eNodeB and Serving GW to control tunnels, paging, etc.
- Interacts with HSS for user authentication, profile download, etc.
- Interacts with SGSN for 2G/3G

S11 MME to SAE GW
GTP-c Version 2

S5 SGW to PDN GW
GTP or PMIP based macro mobility

Data Plane anchoring for 3GPP Access Networks with 2G/3G interworking

- Anchor point for 3GPP IP Access Networks only (2G/3G/LTE)
- Processes all IP packets to/from UE
- Controlled by MME
- Uses network-based mobility towards PDN GW (GTP or PMIPv6)

Subscriber-aware Data Plane anchoring for all Access Networks

- Common anchor point for all IP Access Networks (3GPP and non-3GPP)
- Assigns/owns IP-address for UE (v4/v6)
- Processes all IP packets to/from UE
- Can be in home and/or visited network

X2 inter ba
SCTP/IP fo
GTP-u for t

LTE/SAE System Components

S1-c Base Station to MME interface

Multi-homed to multiple MME pools

SCTP/IP based

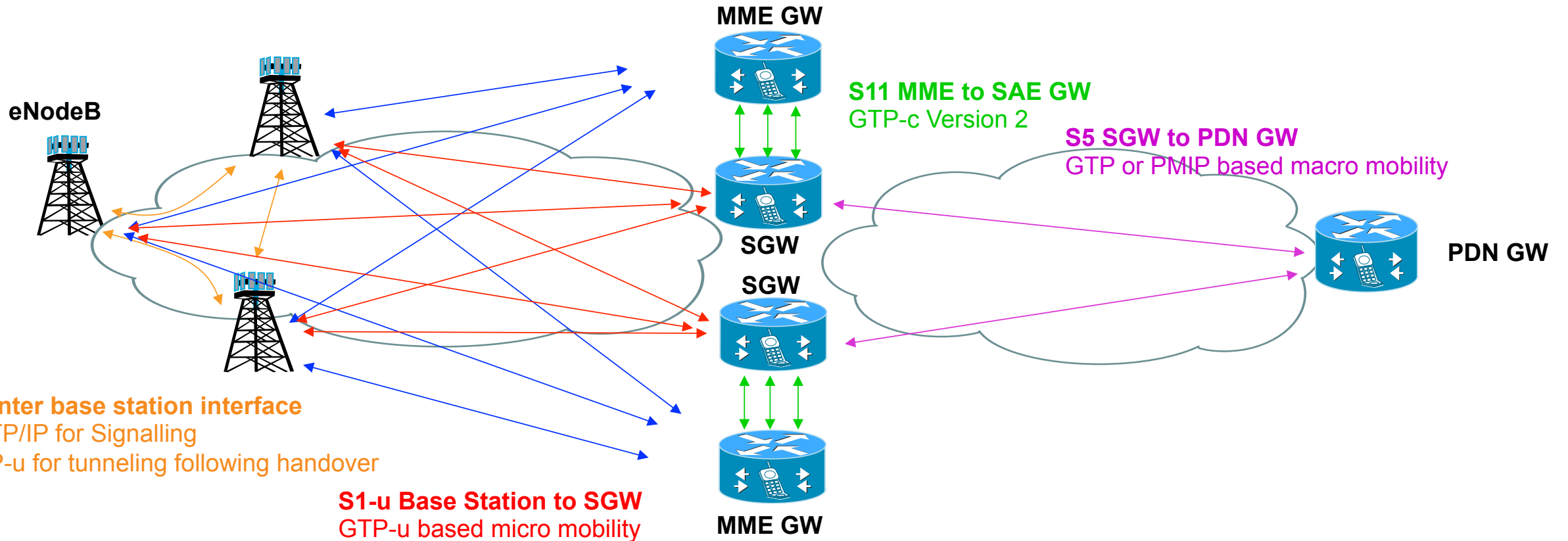

LTE QoS Class Identifier

QCI Value	Resource Type	Priority	Delay Budget ⁽¹⁾	Error Loss Rate ⁽²⁾	Example Services
1	GBR	1	100 ms	10 ⁻²	Conversational Voice
2		2	150 ms	10 ⁻³	Conversational
3		3	50 ms	10 ⁻³	Streaming (Conversational Live Streaming)
4		4	300 ms	10 ⁻⁶	Streaming (Buffered)
5	Non-GBR	5	100 ms	10 ⁻⁶	IMS Signalling
6		6	300 ms	10 ⁻⁶	On-net : www, e-mail, chat, ftp, p2p file sharing, progressive video, etc
7		7	100 ms	10 ⁻³	On-net : www, e-mail, chat, ftp, p2p file sharing, progressive video, etc
8		8	300 ms	10 ⁻⁶	Background : Internet
9		9			

- First end to end Mobile QoS architecture
- Latency reduced to 20ms
- Increased capacity/bandwidth

EPS Bearers

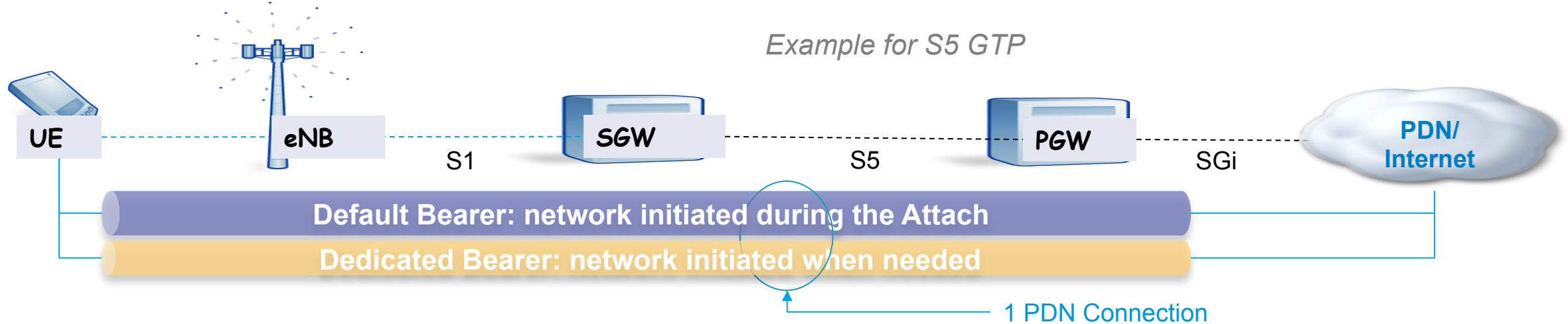

- An EPS bearer uniquely identifies traffic flows that receive a common QoS treatment between a UE and a PDN GW (GTP) or SGW (PMIP)
- Default bearer is assigned during attach and provides always-on IP connectivity
Internet-like default connectivity for QoS-agnostic needs (browser, email, etc.)
- Dedicated bearer is assigned only when needed to provide guaranteed bit rate QoS control
Assigned only for those QoS sensitive applications that can be recognized

Conceptual IMS Call Setup in LTE

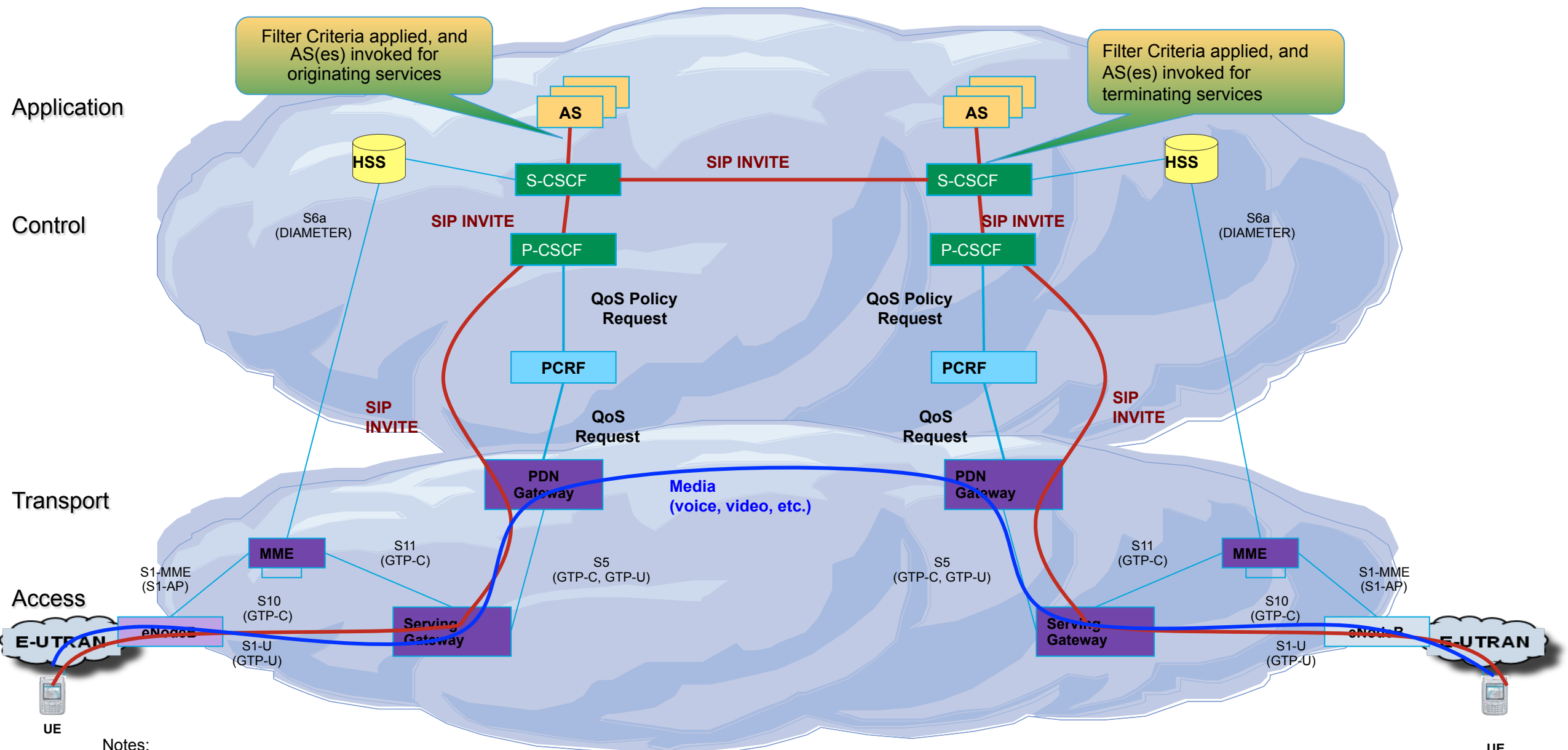

Notes:

- Local Breakout not shown for simplicity
- Partial and simplified call flow only

Road to LTE-Advanced

- version of LTE that addresses IMT-Advanced requirements
- Rel. 10 LTE-Advanced - backwards- and forwards-compatible with LTE
- Features (Rel.10 + Rel.11):
 - Carrier aggregation
 - Higher order downlink MIMO (up to 8X8 in Release 10)
 - Uplink MIMO (two transmit antennas in the device)
 - Coordinated multipoint transmission (CoMP) in Release 11
 - Heterogeneous network (Het-net) support including enhanced Inter-Cell Interference Coordination (eICIC)
 - Relays

IMT-Advanced vs. LTE-Advanced

Item	IMT-Advanced Requirement	LTE-Advanced Projected
Downlink Peak Data Rate		1 Gbps
Uplink Peak Data Rate		500 Mbps
Spectrum Allocation	up to 40 MHz	Up to 100 MHz
Latency – User Plane	10 ms	10 ms
Latency – Data Plane	100 ms	50 ms
Peak Spectral Efficiency DL	15 bps/Hz	30 bps / Hz
Peak Spectral Efficiency UL	6.75 bps/Hz	15 bps/Hz
Average Spectral Efficiency DL	2.2 bps/Hz	2.6 bps/Hz
Average Spectral Efficiency UL	1.4 bps/Hz	2.0 bps/Hz
Cell-Edge Spectral Efficiency DL	0.06 bps/Hz	0.09 bps/Hz
Cell-Edge Spectral Efficiency UL	0.03 bps/Hz	0.07 bps/Hz

Agenda



From 2G to 3G

Introducing LTE

Femtocells

WLAN standards update

Improving Wi-Fi User Experience

Interfacing Wi-Fi with Mobile

Network Discovery and Selection for Mobile

Future Outlook and Summary

Addressing Exponential Growth of Traffic

A shift from outdoor consumption to indoor

70% of mobile traffic to be video by 2016

Lack of spectrum and inability to rapidly increase number of cell sites

Economics of indoor offload and small cell systems

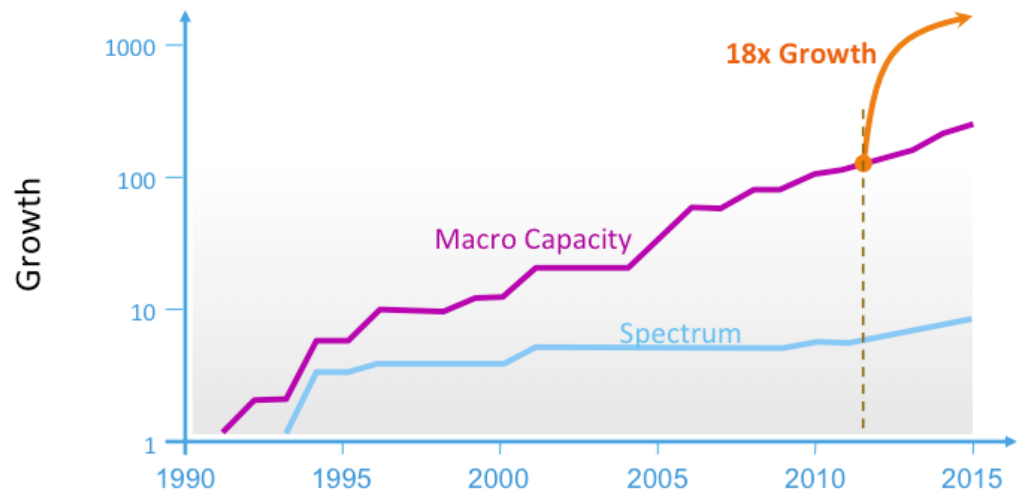

Source: Agilent

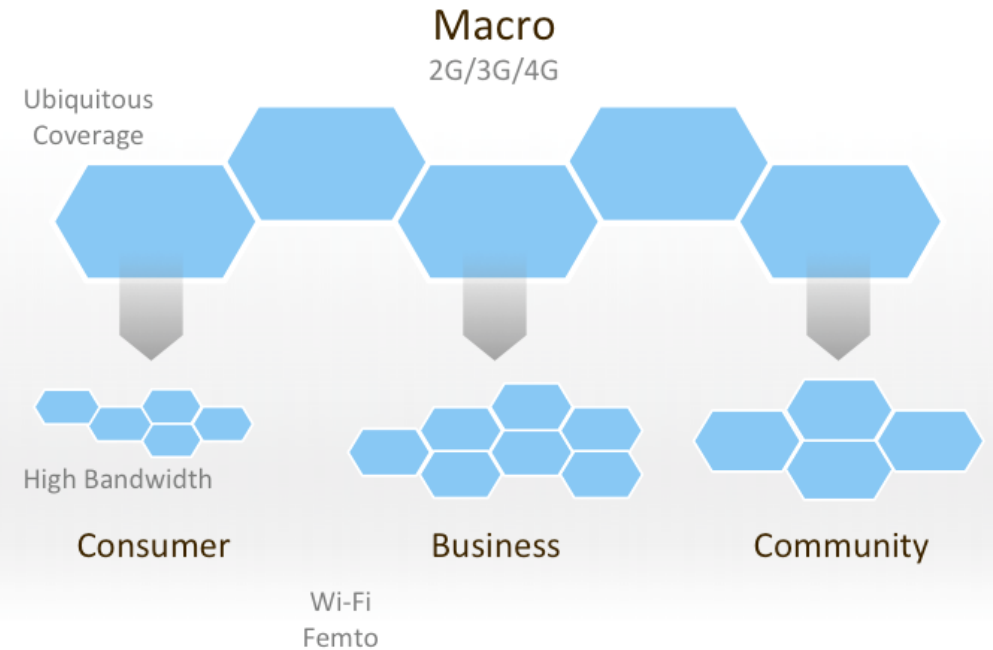

Overall Capacity Not Keeping Pace with Data Demand

Small Cells Increase Existing Capacity

What Is a Femtocell?

Contrast With Macro

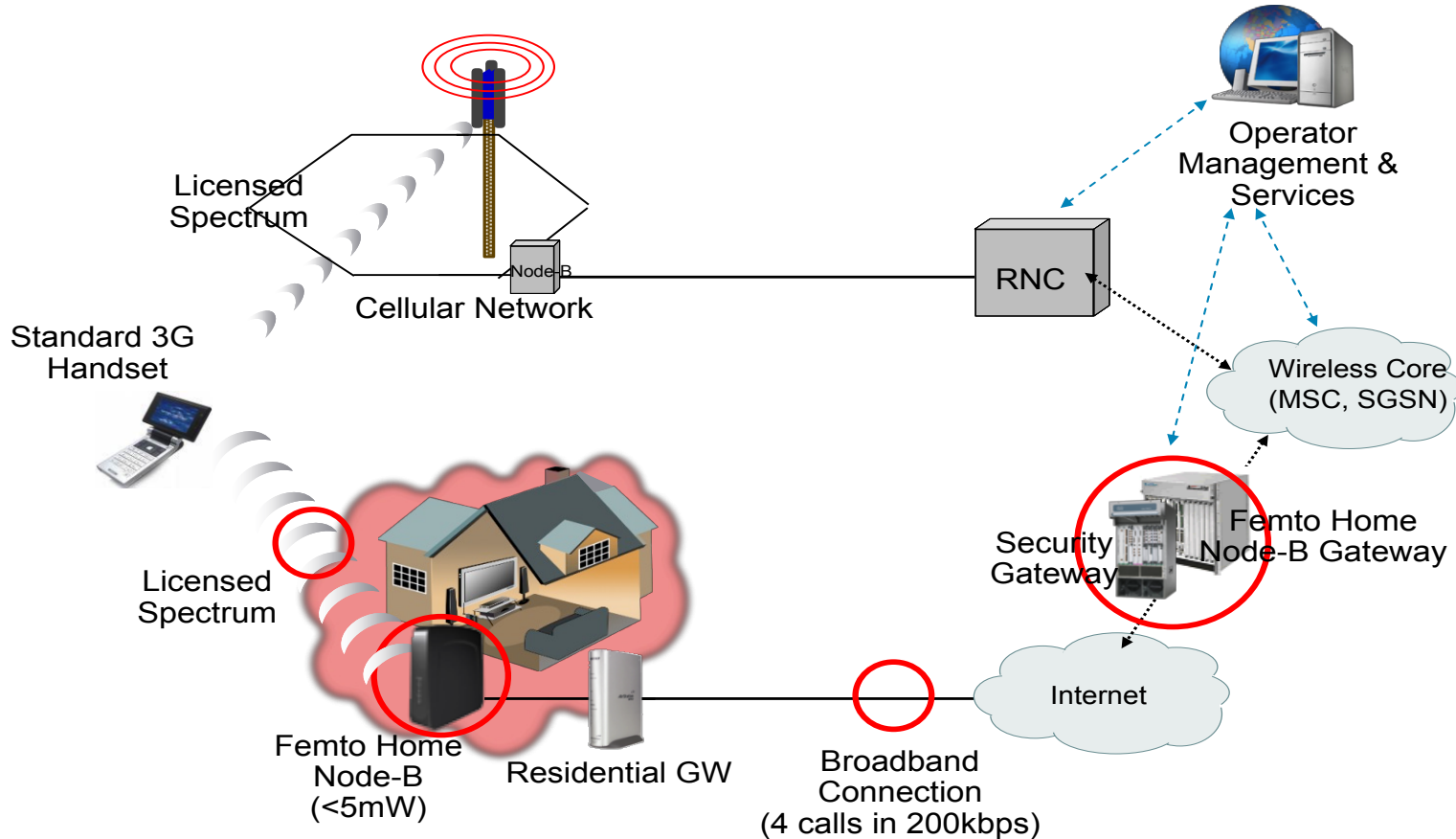

Femto Cellular Network

Tiny 3G Home Access Point

- Gives 3G signal inside the home
- Very low RF power.
- Standalone or integrated into home gateway.
- Works with all standard handsets.

Connects to the Core Network via the Internet

- Uses home broadband connection for backhaul (contrast: Dedicated backhaul)
- Requires Wireless Security Gateway for protection





Standard Connectivity to Core

- Connectivity from Femto network to Core similar to Macro network

Cost Reduction

- Offload Macro Network
- Reduce RAN Backhaul OpEx

Multiple Femtocell Markets and Requirements

Features	Residential 	SoHo/SMB 	Enterprise 	Metro 
# of Users	4-8	8-16	16-64	32-128
Max Tx Power	20 mW	100 mW	250 mW	5W (2W typical)
Access Technology	3G	3G (LTE opt.) WiFi integration	3G (LTE future) WiFi integration	3G and LTE WiFi integration
Access Mode	Closed	Closed/Hybrid	Hybrid/Open	Open
Mobility	Hand-out (opt.-in)	Hand-out, -in	Handout, -in and F-F	Handout, -in and F-F
Standards	lth	lth (S1/X2 for LTE)	lth/lurh (S1/X2 for LTE)	lth/lurh (S1/X2 for LTE)
Provisioning	TR069/196 Zero-Touch	TR069/196 Zero-Touch	TR069/196 Site planning	TR069/196 Site planning
FCAPS	Passive	Passive or Active	Passive or Active	Active
Specific feature	None	GPS (optional) NWL, BB IP@/MAC)	Coordinated SON (over group of femto)	Coordinated SON (femto and macro)
Specific Component	None	None	Enterprise Controller SON server (opt.)	SON server
Services	Location/Presence LIPA/SIPTO	Location/Presence LIPA/SIPTO Enterprise integration	Location/Presence LIPA/SIPTO Enterprise integration	Location/Presence

Cisco AT&T Deployment

- AT&T microcell officially launched in April 2010

<http://www.wireless.att.com/learn/why/3gmicrocell/>

- Largest femtocell deployment
 - Over 650k femtocell active
 - 1.8 Millions of call per day with 7 Millions of minutes
- True zero-touch provisioning
 - Over 92% of femto installation done without customer care intervention
 - Fully automated provisioning and management control (e.g. whitelist management)

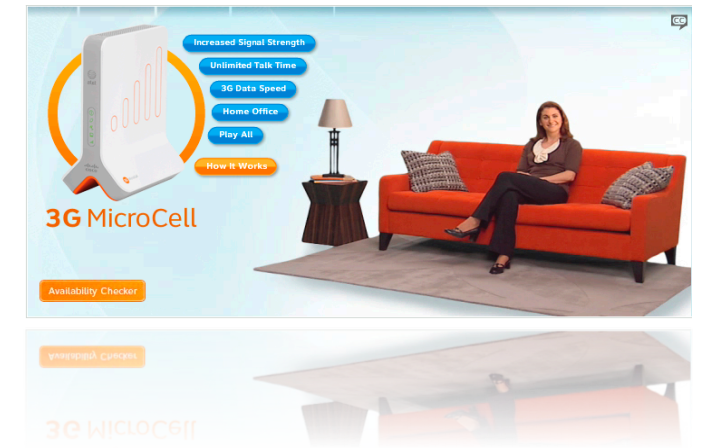

BEST COMMERCIAL FEMTO LAUNCH

AT&T's 3G MicroCell National Deployment



"AT&T's 3G MicroCell deployment with Cisco caught the judges' eyes for two crucial reasons. First and foremost, it emphasised the importance of the customer at the heart of the femtocell experience, positioning technology very much as an enabler, rather than an end in itself. Secondly, the deployment is on a national scale, which given the US market's size adds an additional layer of complexity", agreed the judges.

London, England - June 23, 2010

Agenda



From 2G to 3G

Introducing LTE

Femtocells

WLAN standards update

Improving Wi-Fi User Experience

Interfacing Wi-Fi with Mobile

Network Discovery and Selection for Mobile

Future Outlook and Summary

WiFi Momentum

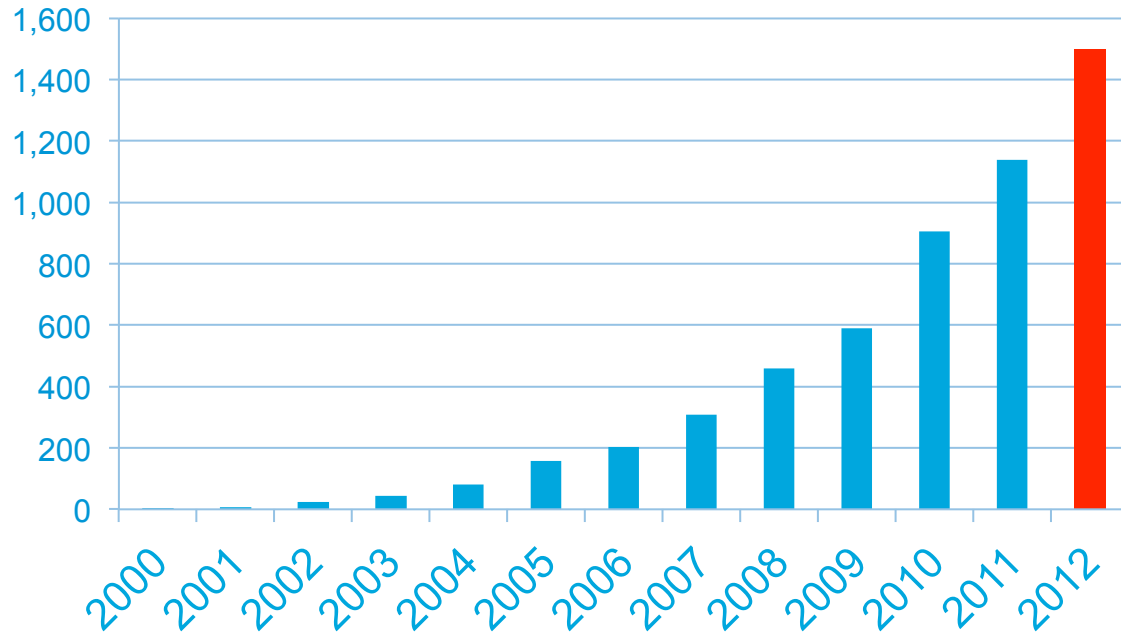

WiFi chipsets sold per annum [millions]

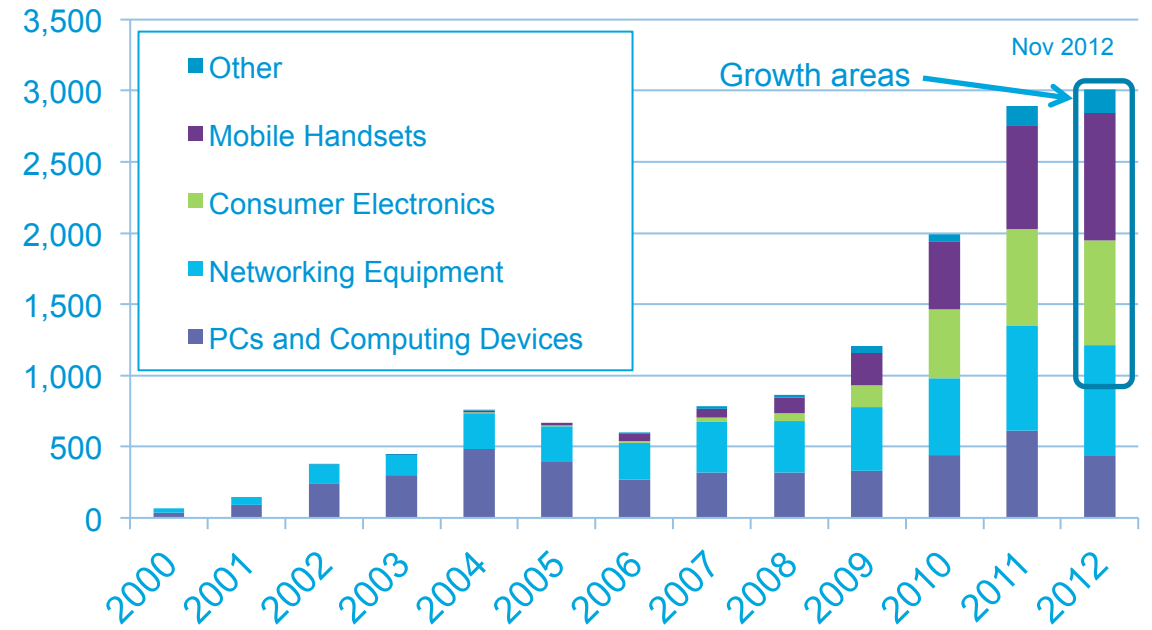

WiFi Alliance product certification per annum

Wi-Fi connectivity today is based on the 802.11a/b/g/n PHY standards ... 11ac is “just around the corner”

Band	Technology				
	DSSS	OFDM			
2.4Ghz	802.11b-1999	802.11g-2003	802.11n-2009 (D2.0-2006)	The Future	
5GHz		802.11a-1999			
PHY rate	<11Mb/s	<54Mb/s	<600Mb/s	<3500Mb/s	<6900Mb/s
Bandwidth	20Mhz	20Mhz	Up to 40Mhz	Up to 80Mhz	Up to 160Mhz
Modulation	Up to 64QAM	Up to 64QAM	Up to 64QAM	Up to 256QAM	Up to 256QAM
Beamforming	No	No	Yes	Yes	Yes
MIMO	No	No	Up to 4x4 SU	Up to 8x8 SU	Up to 8x8 MU
Spatial Streams	1	1	1-4	1-3**	1-4**
Typical Midtier product user BW*	<6 Mbps	<24 Mbps	<210 Mbps@2ss	<610Mbps@2ss	<1200Mbps@2ss
High-end and Ultra High-end product user BW*	<6 Mbps	<24 Mbps	<320 Mbps@3ss	<910Mbps@3ss	<1800Mbps@3ss <2400Mbps@4ss

Use of 60GHz by 802.11ad (aka WiGig) possibly future for high-speed room coverage

- A lots of spectrum available (~ 7 GHz varies by country regulation)
 - ⇒ very high speeds > 1Gb/s easily achievable
 - ⇒ Real to Achieve at least PHY 1.2Gb/s using 2520MHz, 1 spatial stream
 - ⇒ Real to Achieve of PHY 4.6Gb/s @ ~10m, using 2520MHz, 1 spatial stream
- Waves in 60GHz spectrum propagates like light
 - ⇒ Easily blocked by books, humans, whiteboards, walls & concrete
 - ⇒ But much less interference from neighbours
- Potential applications
 - WLAN, Wireless docking, Wireless peripherals, Sync'n'go, HDMI replacement
- Certification status
 - 802.11ad ratified Q4/2012
 - Wave1 certification est. Q4/2013 – focus on peer to peer functionality (Wireless USB/PCIe/AV, ..)
 - Wave2 certification est. Q4/2014 – first AP => unlikely to see 802.11ad AP before 2015!

Agenda



From 2G to 3G

Introducing LTE

Femtocells

WLAN standards update

Improving Wi-Fi User Experience

Interfacing Wi-Fi with Mobile

Network Discovery and Selection for Mobile

Future Outlook and Summary

Connecting to a Wi-Fi Hotspot is Way too Hard Today for the Average Person

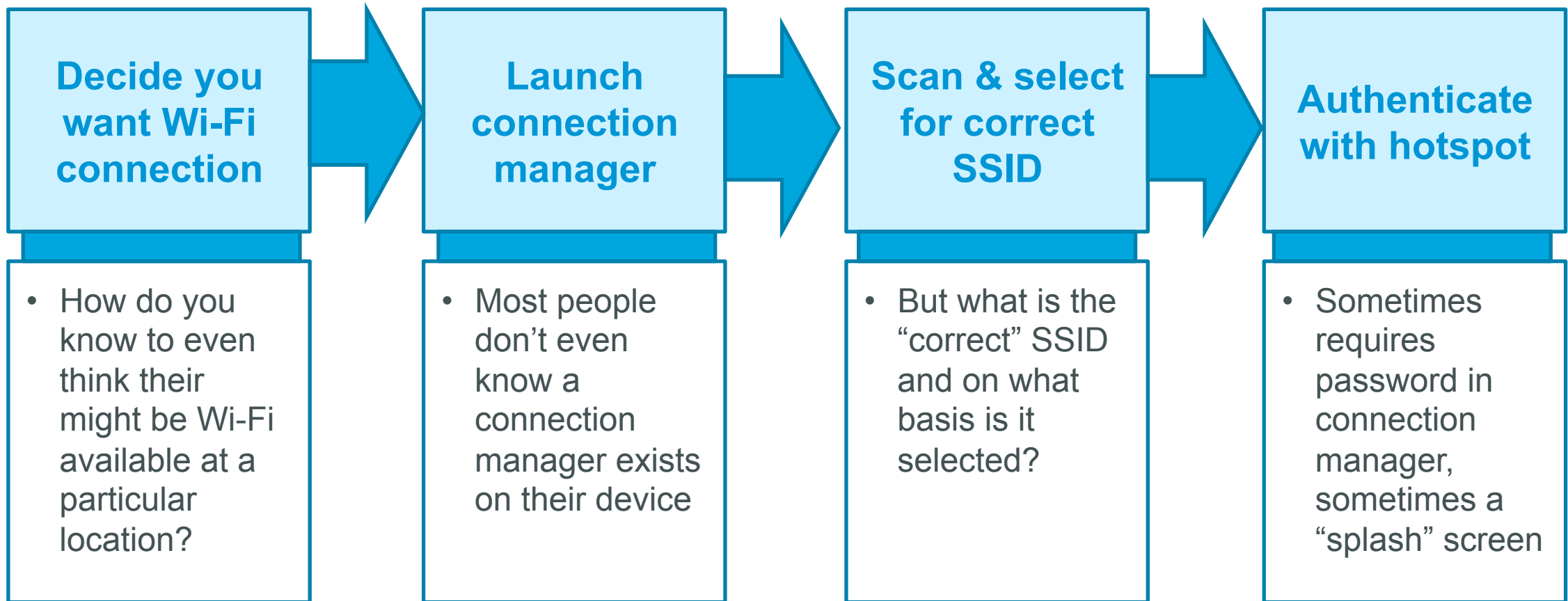



Passpoint/Hotspot 2.0 enablers and pillars

Authentication and Roaming	Hotspot (Today)	HS2.0 Spec	Note
Network Discovery and Selection	SSID	802.11u	GAS/ANQP Protocol to assist automatic selection of most appropriate hotspot - either home or partner SP, Based on a range of parameters available before association
L2 Access Control	None	802.1X	Provides secure connectivity. WPA2-Enterprise security eliminates today's attacks such as session high-jacking (theft of service), side-jacking (Firesheep), evil twin AP (identity theft) and eavesdropping
Layer 2 Air Encryption	None	802.11i	
L3 Authentication	WebAuth WISPr	EAP-SIM, AKA, TLS, TTLS	Technical foundation for global, Wi-Fi roaming, SIM, USIM, Credential Certificate, Username and Password with Server side certificates
Hotspot Network	Untrusted	Trusted	Hotspot-specific security features mitigates Public WLAN attack vectors.
Interoperable	No	Yes	Standard based native connection manager in mobile device Drives network selection based on user preferences, network conditions and operator policy.

On-line signup to obtain credentials from SP and delivery of policy from home SP will be covered by next release.

Network Selection with 802.11u: GAS/ANQP Messages

Identifying Authentication Domains

- **NAI Realm List**

A list of **realms** (i.e., username@realm) which can be successfully authenticated

If the mobile device finds a realm in the list matching one of its credentials, successful authentication is possible

Either EAP-TLS (certificate credential) or EAP-TTLS with MSCHAPv2 (username/password credential) is used depending on the credential type provisioned by the Home SP

- **3GPP Cellular Information**

A PLMN ID list; a PLMN ID is assigned to every cellular operator and has the form {MCC, MNC}

If the mobile device finds a PLMN ID in the list matching the one from its SIM credential, successful authentication is possible

Either EAP-SIM (2G/3G SIM credential) or EAP-AKA (4G USIM credential) is used depending

- **Roaming Consortium List**

A list of OUIs (organizationally unique identifier)—essentially the OUI part of a MAC address obtained from IEEE

If the mobile device finds an OUI in the list matching the one it's been provisioned with, successful authentication is possible

This method can be used with Aggregators (e.g., iPass) and for other special purposes

For OUIs in the beacon, this is a very battery efficient roaming method (no ANQP queries needed)

The home SP is no longer required to manage long SSIDs lists on every mobile device. This responsibility has been transferred to the network!

802.11u/HS 2.0 operation

AP/WLC can sets all the IE parameters but handset connection policy may only use subset of it.

Handset



802.11u(ANQP Client)

1. Found Operator HotSpot !

2. Active Scanning

3. Query Details

Operator Policy Check list

YES

4. WPA2 -Enterprise Auth



802.11u processing

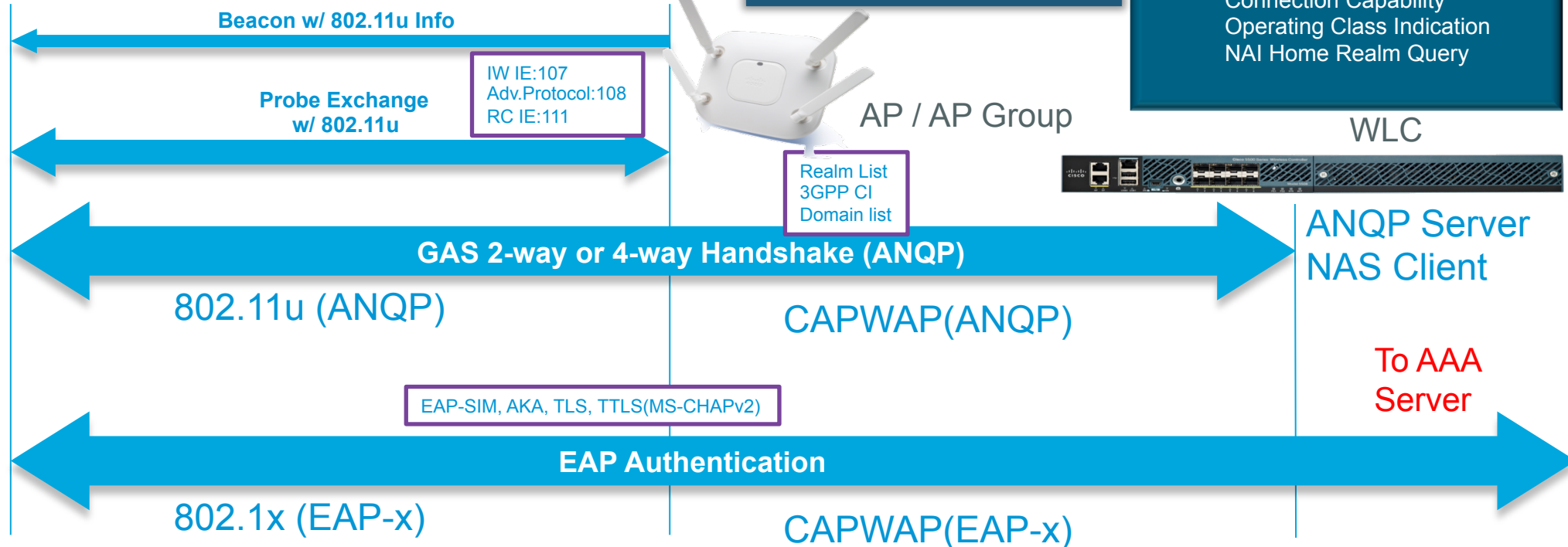

Beacons Broadcasted

Interworking Info.
 Venue Group,
 Venue Type
 HESSID
 Access Network Type
 Internet Service
 WebAuth Required
Advertisement Protocol Info
 ANQP
Roaming Consortium Info
 OIs Info
BSS Load Element

ANQP info - Query based

802.11u Std
 Venue Name
 Roaming Consortium list
 Network Authentication Type
 NAI Realm list
 3GPP Cellular Network Info.
 Domain Name list
 IP address type
HotSpot 2.0 ANQP element
 HS Query list
 HS Capability list
 Operator Friendly name
 WAN Metrics
 Connection Capability
 Operating Class Indication
 NAI Home Realm Query

Example: Connection Manager Selecting a Network Using Scanning and Policy

- Mobile device has certificate credential for **SP.com**.
- Mobile device scanned and found 5 HS2.0 networks
- Mobile performed GAS/ANQP query and discovered that 4 of the 5 hotspots had **SP.com** as a roaming partner

Subscription MO->Policy->
PreferredRoamingPartnerList

FQDN	Priority
bar.com	1
verizon.com	10
orange.com	130
default	128

ANQP Query Responses

Hotspot No.	SSID	Domain Name List ¹	NAI Realm List + 3GPP Info ²	Policy Priority
1	FT	orange.com	280-00, sp.com	130
2	Ozone	verizon.com	311-480, sp.com	10
3	bar	bar.com	sp.com	1
4	ORD	boingo.com	sp.com, 311-480, 310-260	128
5	dog	cat.com		

Mobile associates to "bar" highest priority network



Can't authenticate

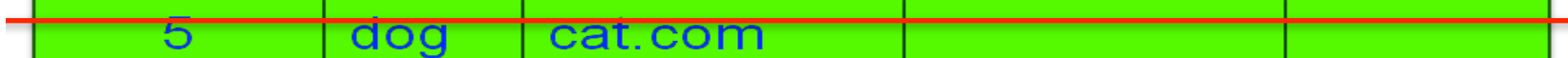

Default priority assigned to hotspot operators not in above list

Notes:
1. Hotspot operator
2. Hotspot roaming partners

NG HotSpot (802.11u): Roam, Authenticate, Monetize Make Wi-Fi as Easy to Use and Secure as Cellular



RELIABLE
Carrier class solution

SEAMLESS
Simplifies network discovery and selection for seamless cellular data offload

SECURE
Extends existing SIM-based authentication techniques over encrypted Wi-Fi

PROFITABLE
Enables location-based and value-added services

Agenda



From 2G to 3G

Introducing LTE

Femtocells

WLAN standards update

Improving Wi-Fi User Experience

Interfacing Wi-Fi with Mobile

Network Discovery and Selection for Mobile

Future Outlook and Summary

... and many people want to use Wi-Fi rather than 3G/4G on their smartphones

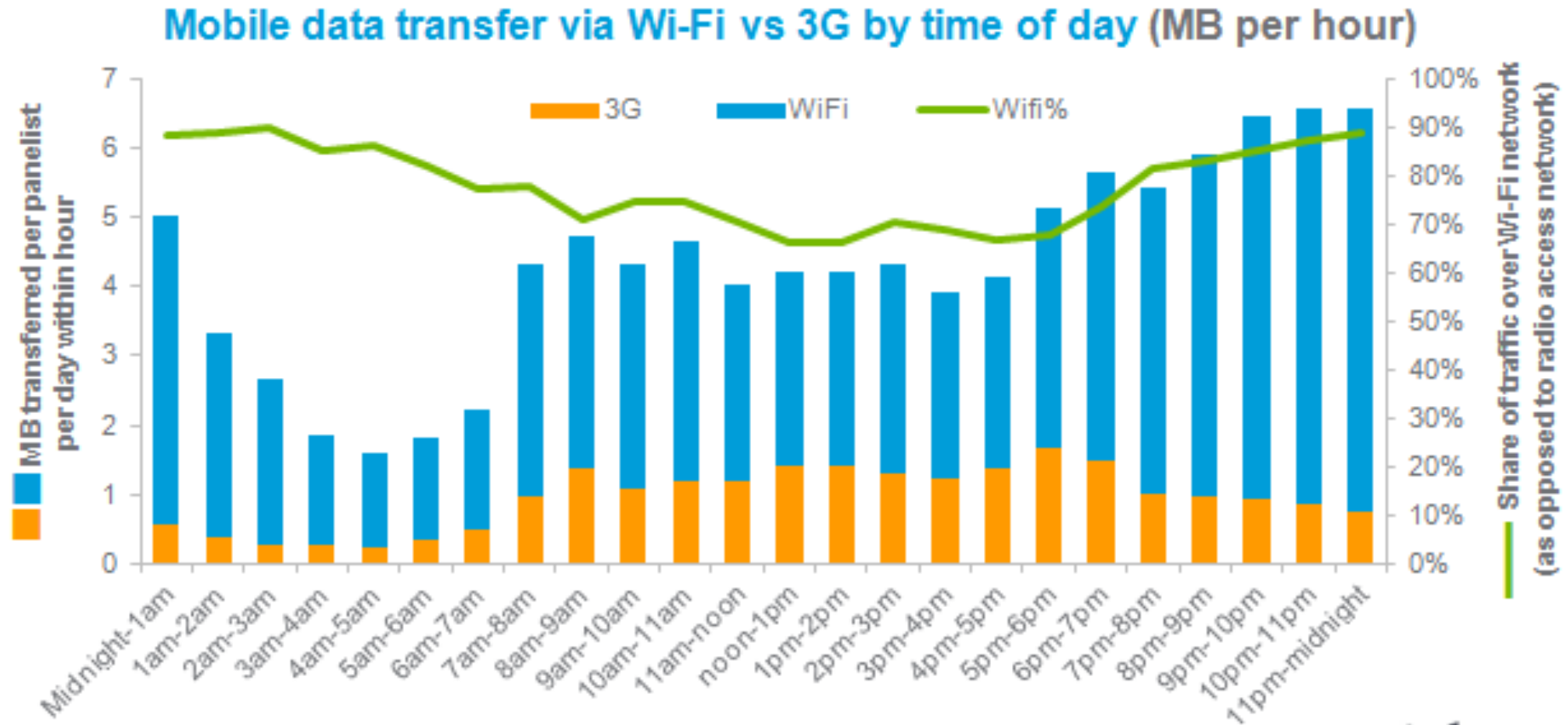

Source: Nielsen; 1-30 September 2012

E.g. Between midnight and 1am, 88% of data downloaded by UK adult Android smartphone owners is via Wi-Fi (green line)



Wi-Fi Subscribers, Wireline/Wi-Fi & Mobile *Different Motivations*

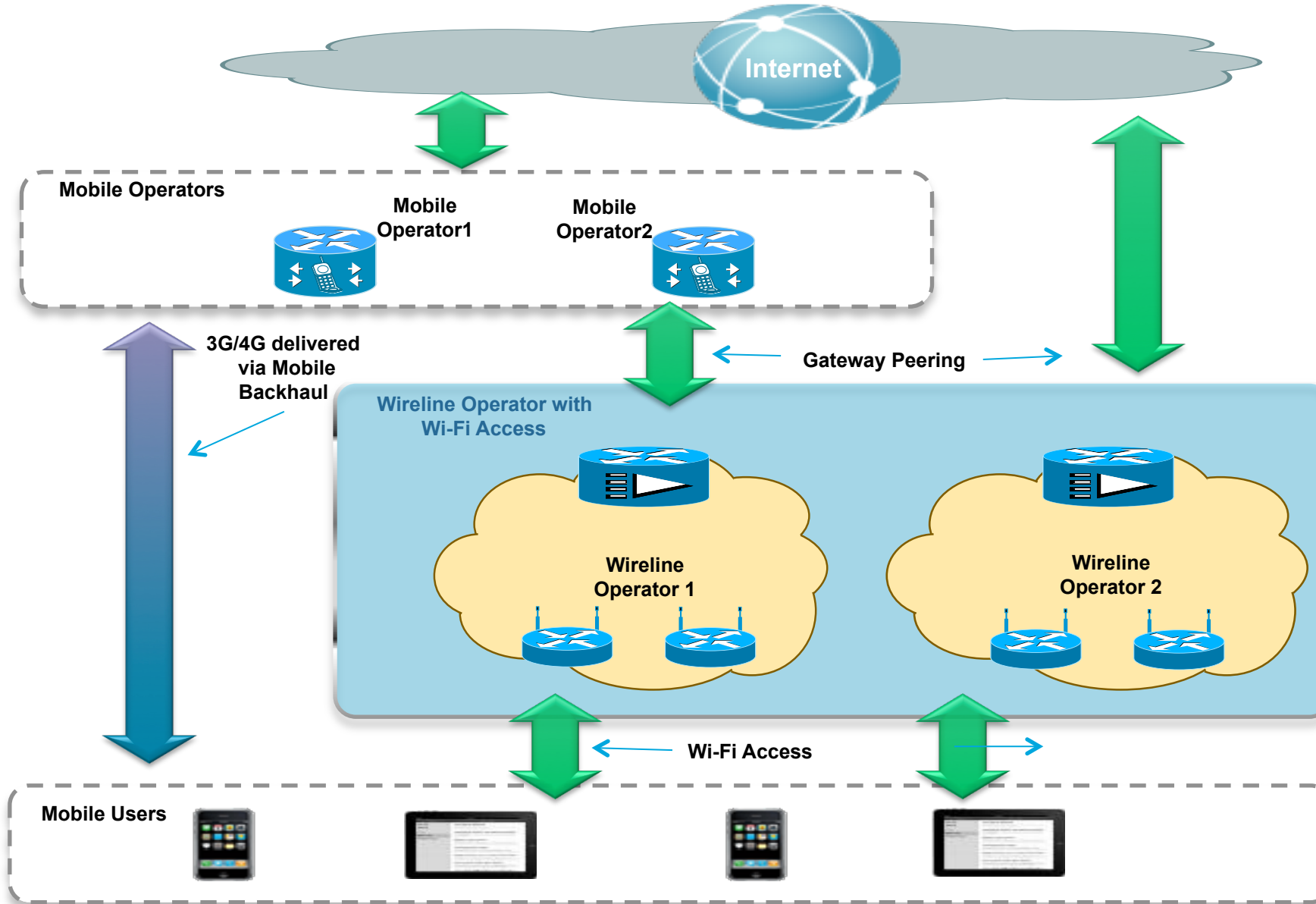

Mobile Operator Motivations

- Data traffic growing exponentially
- Licensed spectrum limitations
- Access – Trusted/Untrusted

Wireline / Wi-Fi Operator Motivation

- Increase Service Revenues
- Cater to multiple Mobile Operators
- Provide a scalable peering model
- Leverage existing infrastructure

Subscriber Motivation

- Always connected experience
- Seamless Authentication
- Mobility/Roaming without disrupting apps

SP Wi-Fi Architectures Today

- Two Solitudes

- Separate Cores: Hotspot Core vs. MPC
- Separate Billing Infra
- Separate Policy Infra: Diameter vs. Radius Policy
- Separate Authentication Mechanism/ Database

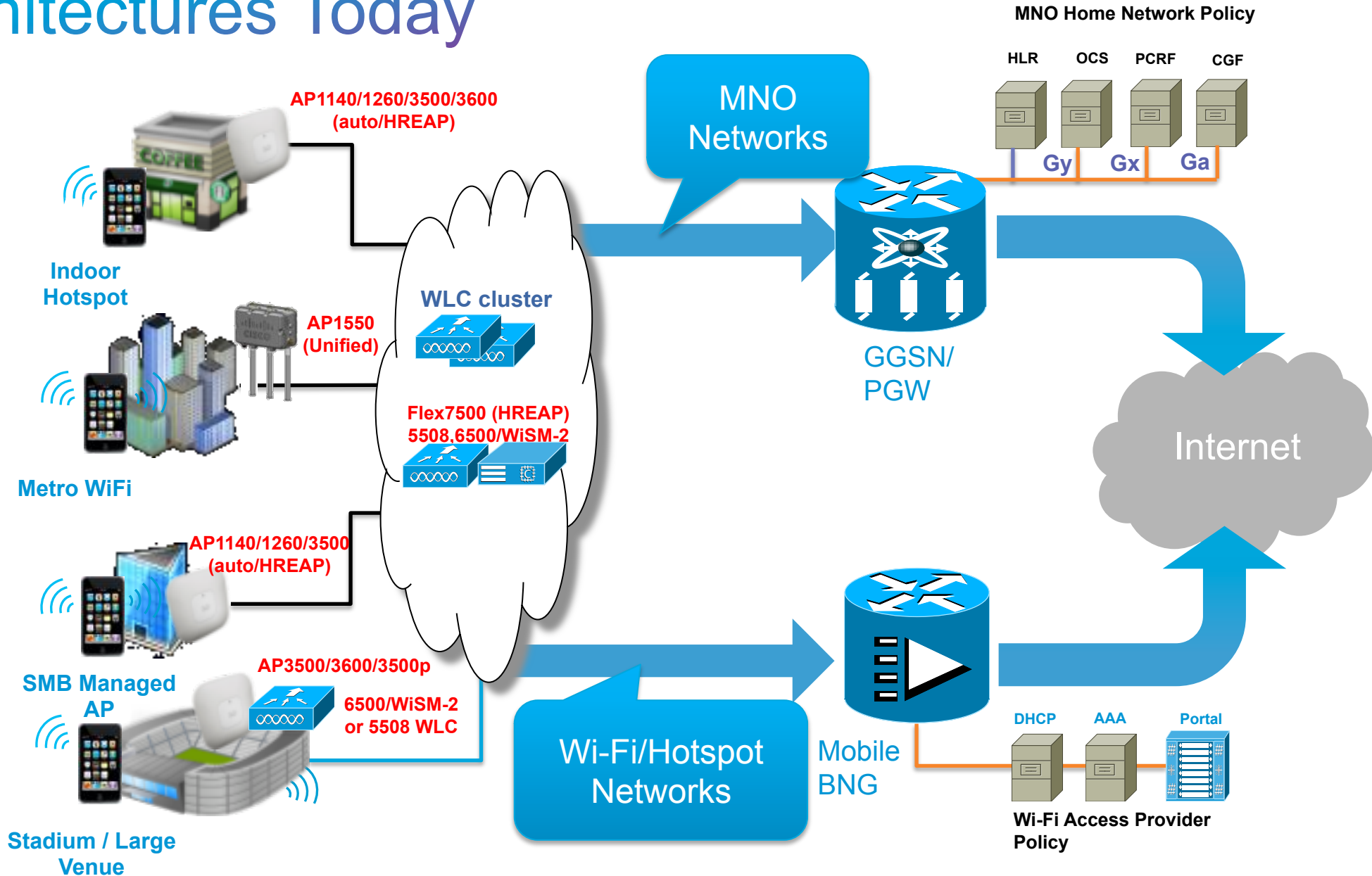

Evolution in Service Provider Architectures



Diverged
"Per Service"
Networks

Converged
"All in One"
Networks

Converged
"User Centric"
Networks

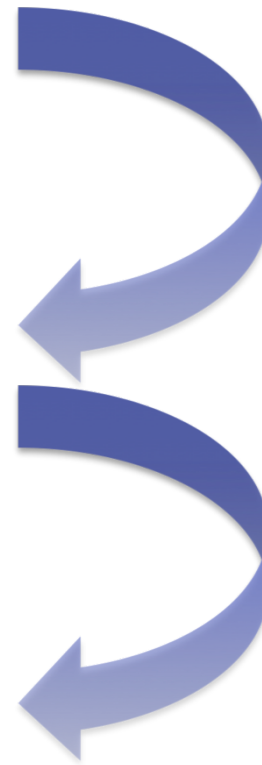

Reduced Operational Expenses:

- ✓ Consolidation of multiple networks

Increased Service Revenues:

- ✓ Customized services
- ✓ Rapid deployment of new services
- ✓ Subscriber Self Subscription and Self Care

Cisco Tools for Session Management

Intelligent Services Gateway on ASR1000

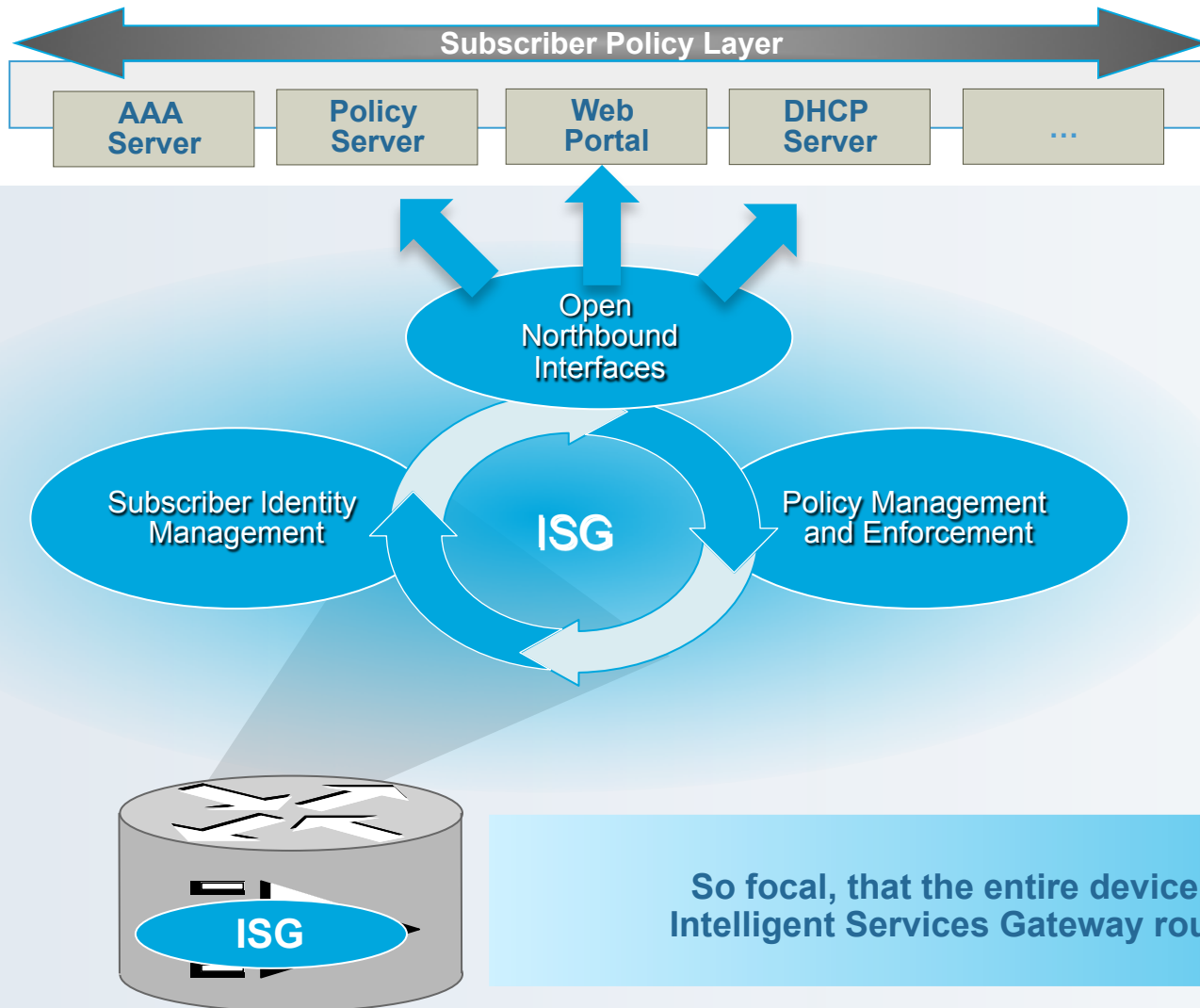

- Cisco **Intelligent Services Gateway (ISG)** Cisco IOS feature on WAG that provides **Session Management** and **Policy Management** services to a variety of access networks
- ISG is the subscriber management solution for many hotspot and SP-Wi-Fi deployments today
- Deployed at the Internet Edge (Standalone) or in Aggregation

So focal, that the entire device is often referred as an: Intelligent Services Gateway router or simply "The ISG"



Cisco SP Wi-Fi Architecture

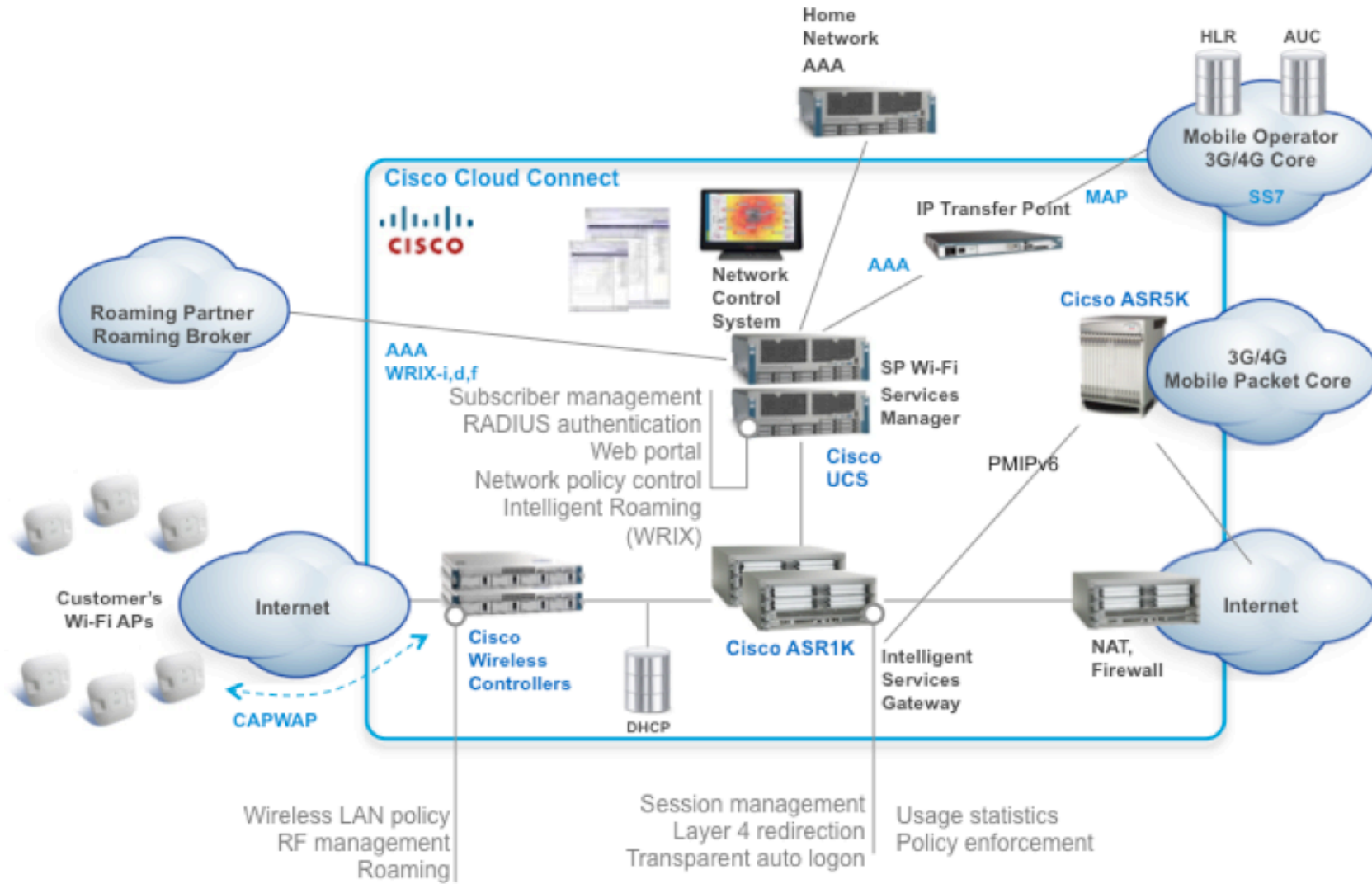

Network-based Mobility using PMIPv6

PMIPv6 protocol integrates non-3GPP access networks and supports a common IP mobility architecture

- Maintains key mobility parameters constant throughout the infrastructure
 1. MN's IP address & Anchor Point (**LMA**)
 2. MN's Gateway IP address
 3. Gateway's MAC (or Link-Layer address in IPv6) – RFC6543
- Tracking the movement of the MN – intra & inter MAG movements
- Additionally, the DHCP server's IP address is kept consistent and reachable throughout the infrastructure

Note: PMIPv6 supports both IPv4 & IPv6 on Mobile Node and on transport link between MAG and LMA

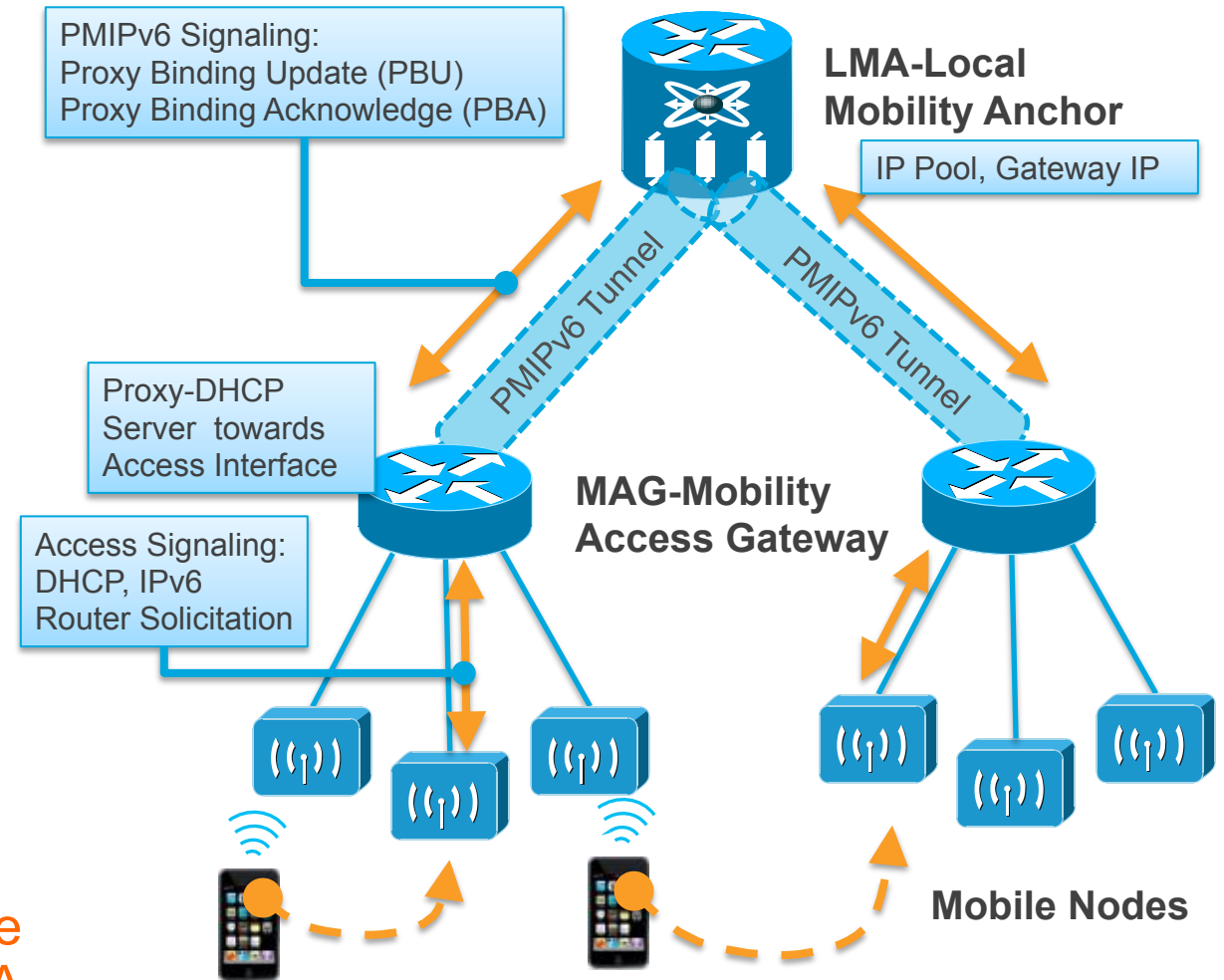

Components of SP Wi-Fi for Wi-Fi only subscribers

No Integration with Mobile Network

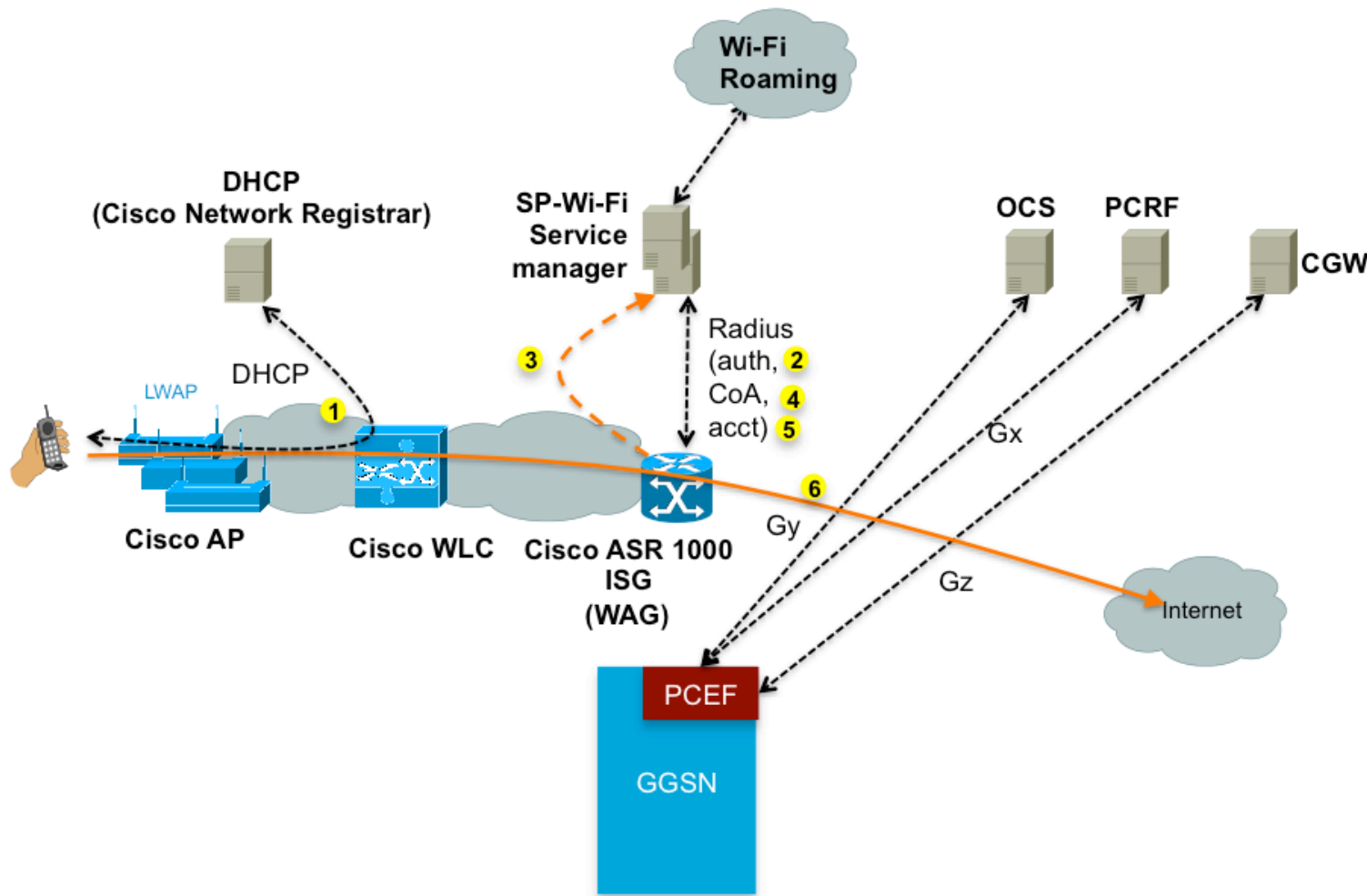

1. Open SSID associated, IP address assigned
2. First packet triggers authentication from Cisco ISG based on MAC (RADIUS auth)
3. If MAC has not yet been authenticated, subscriber is redirected to login portal
4. After authentication, Backend systems uploads policy data (stored in user database) to Cisco ISG (RADIUS CoA)
5. User sessions is opened and RADIUS acct is used for charging
6. User data is allowed to Internet

SP Wi-Fi architecture provides user database, policy control and charging. SP Wi-Fi Services Manager provides the central point of service creation.

Components of SP Wi-Fi for Mobile Offload

PCEF in the WAG

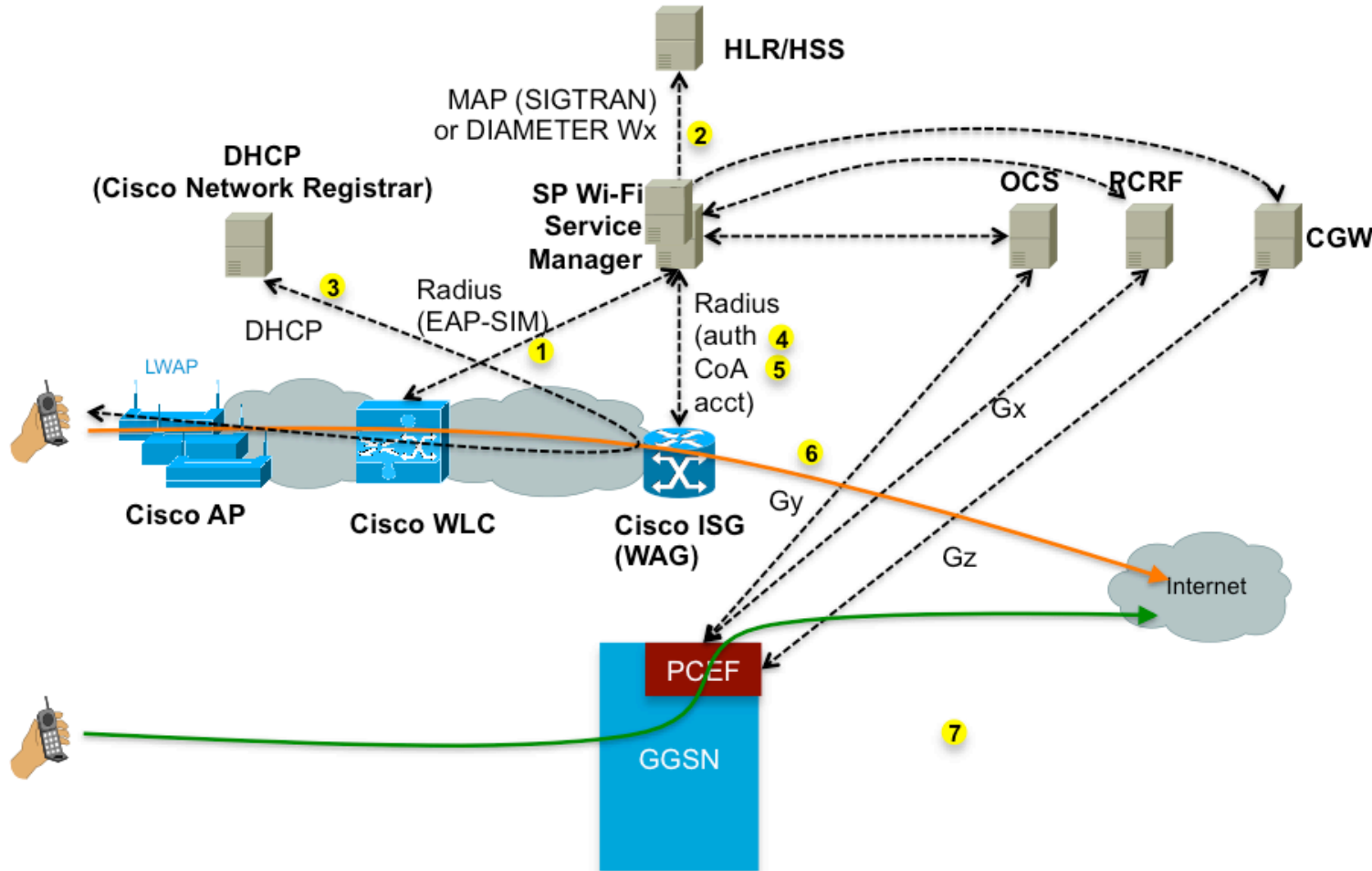

1. Before association, 802.1x with EAP-SIM is used to authenticate subscriber
2. SIM information is checked against HLR
3. After successful authentication, IP address is assigned
4. DHCP triggers session on the ISG, ISG starts authentication with Backend (is allowed, because user was cached during EAP-SIM phase)
5. ISG retrieves the policy for the subscriber from the SP Wi-Fi Service Manager (which gets it from the PCRF)
6. User data is allowed to Internet
7. For charging, accounting from WLC or from ISG can be used. This data is then mediated towards OCS.

SP Wi-Fi Service Manger provides mediation between the RADIUS based policy and charging and the 3G policy and charging systems

What is iWAG ?

ISG Features

- IPoE Sessions: DHCP initiated, unclassified IP or MAC-address initiator, Radius-Proxy initiator
- Layer-4 Redirect
- Traffic Classes
- Postpaid & Prepaid Accounting
- Dynamic Rate Limiting
- Lawful Intercept
- Radius based authentication and accounting
- Radius CoA Interface
- Per-subscriber QoS
- IP Session keep-alives, timeouts
- VRF Transfer
- Port Bundle Host Key (PBHK)
- Walk-by session handling/ optimization
- **Local Breakout of subscriber traffic for Simple IP subscribers**
-and more
- <http://www.cisco.com/go/isg>

GPRS Tunneling Protocol (GTP) for integrating Wi-Fi traffic into Gateway GPRS Support Node (GGSN)

 iWAG = Intelligent Wireless Access Gateway

Mobile Access Gateway (MAG) using Proxy Mobile IPv6 (PMIPv6) for integrating Wi-Fi traffic into Packet Data Network Gateway (PGW)

- iWAG enables SP to integrate trusted non-3gpp (Wi-Fi) traffic into MPC via standard S2a interface

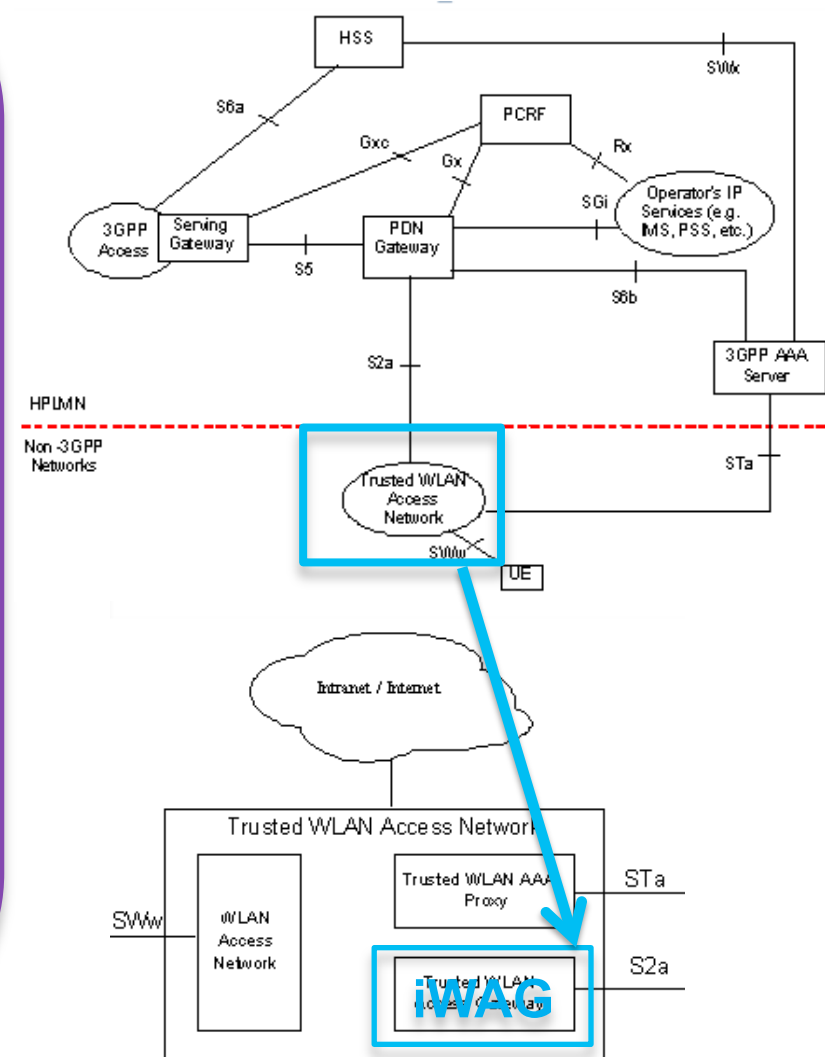

Components of SP Wi-Fi for Mobile Offload

PCEF in GGSN/PGW

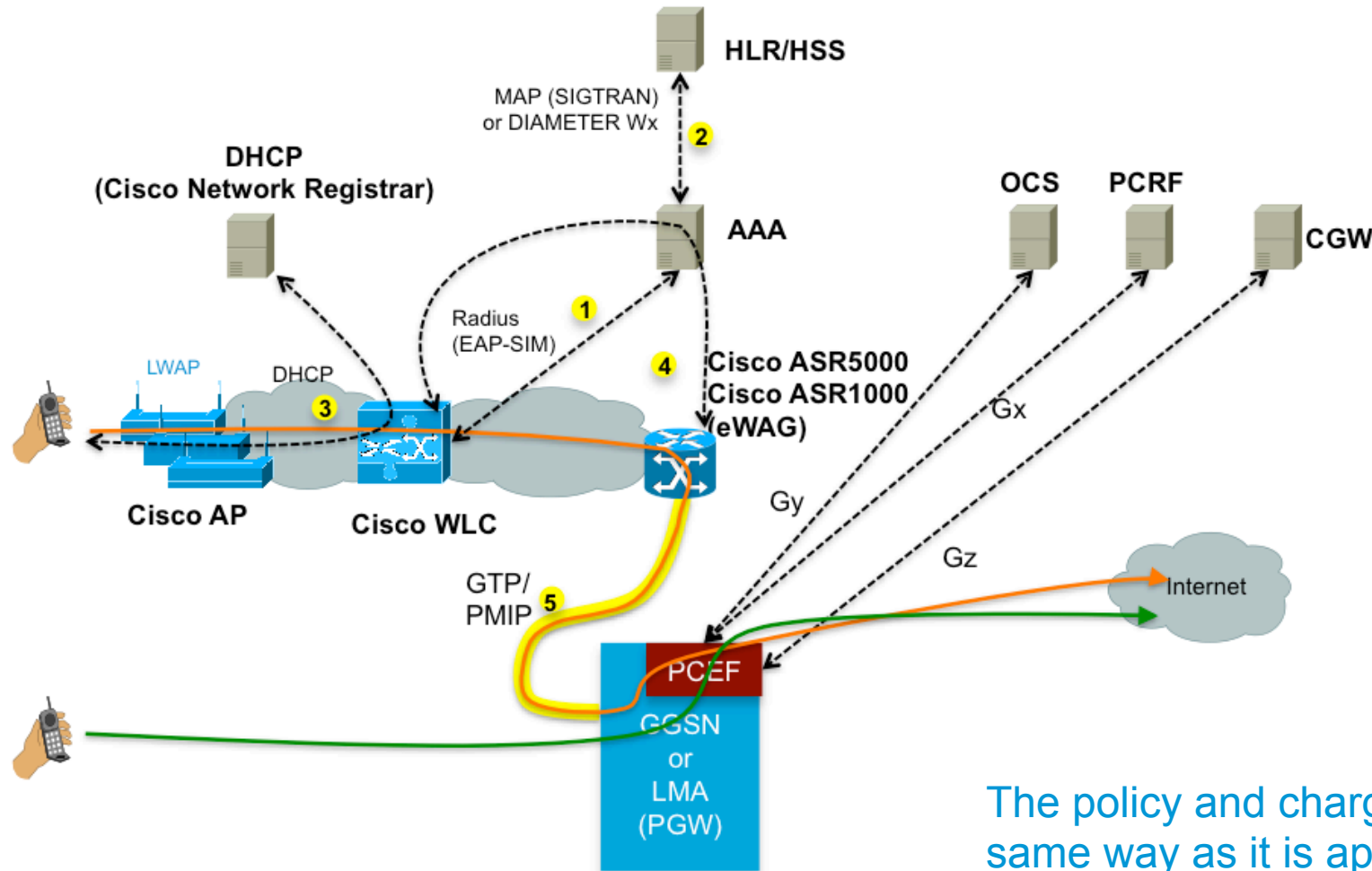

1. Before association, 802.1x with EAP-SIM is used to authenticate subscriber

2. SIM information is checked against HLR

3. After successful authentication, IP address is assigned

4. Radius Accounting triggers the session on the Cisco eWAG

5. eWAG opens GTP or PMIP tunnel to the Gateway

6. Gateway performs all PCC related processing

The policy and charging is applied to Wi-Fi session in the same way as it is applied to 3G/4G data connections.

Wi-Fi Aggregation with 4G Mobile Packet Core (example)

- other 3G/4G scenarios can be also supported

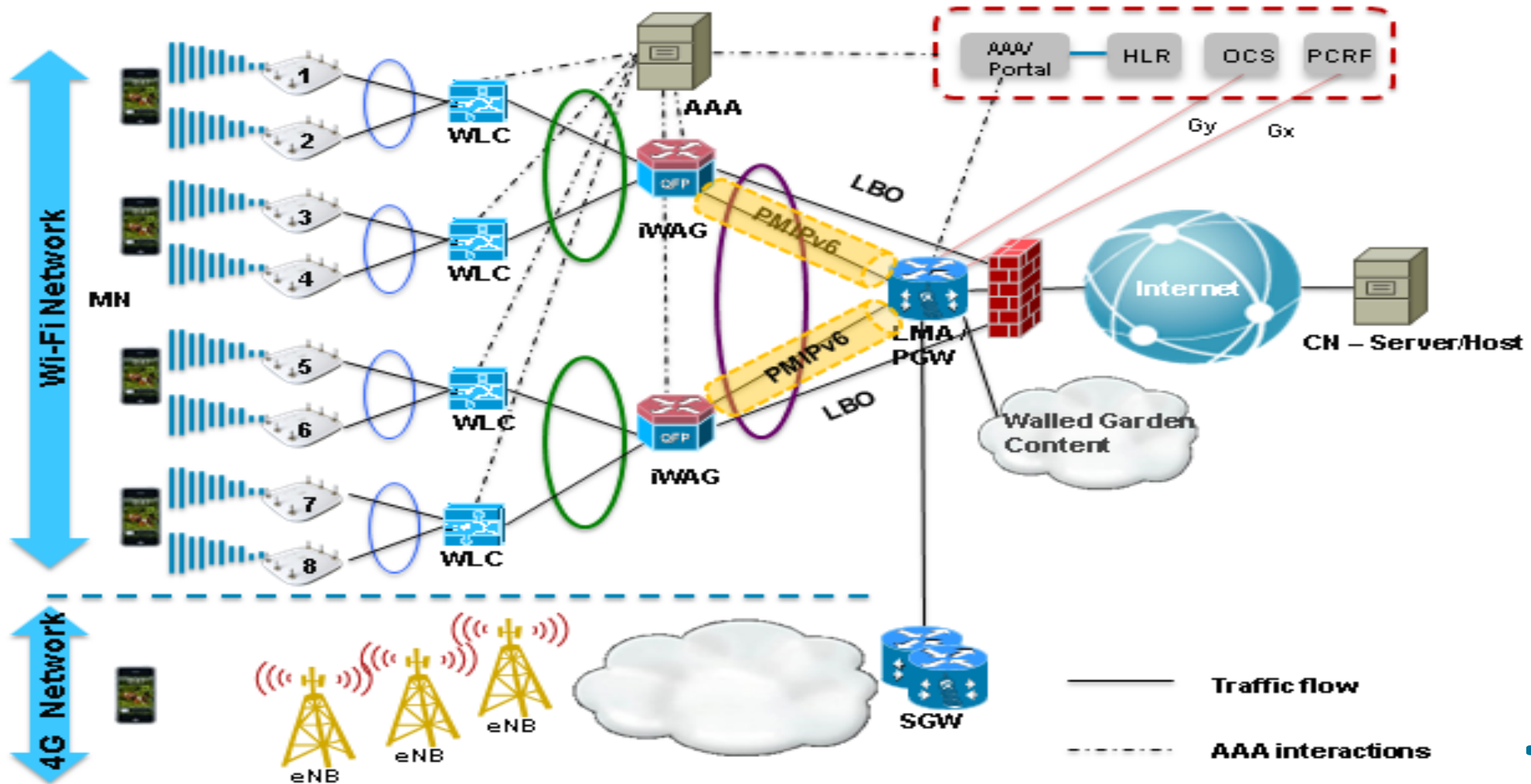

Wi-Fi Aggregation with Multiple Mobile Network Operator (MNO)

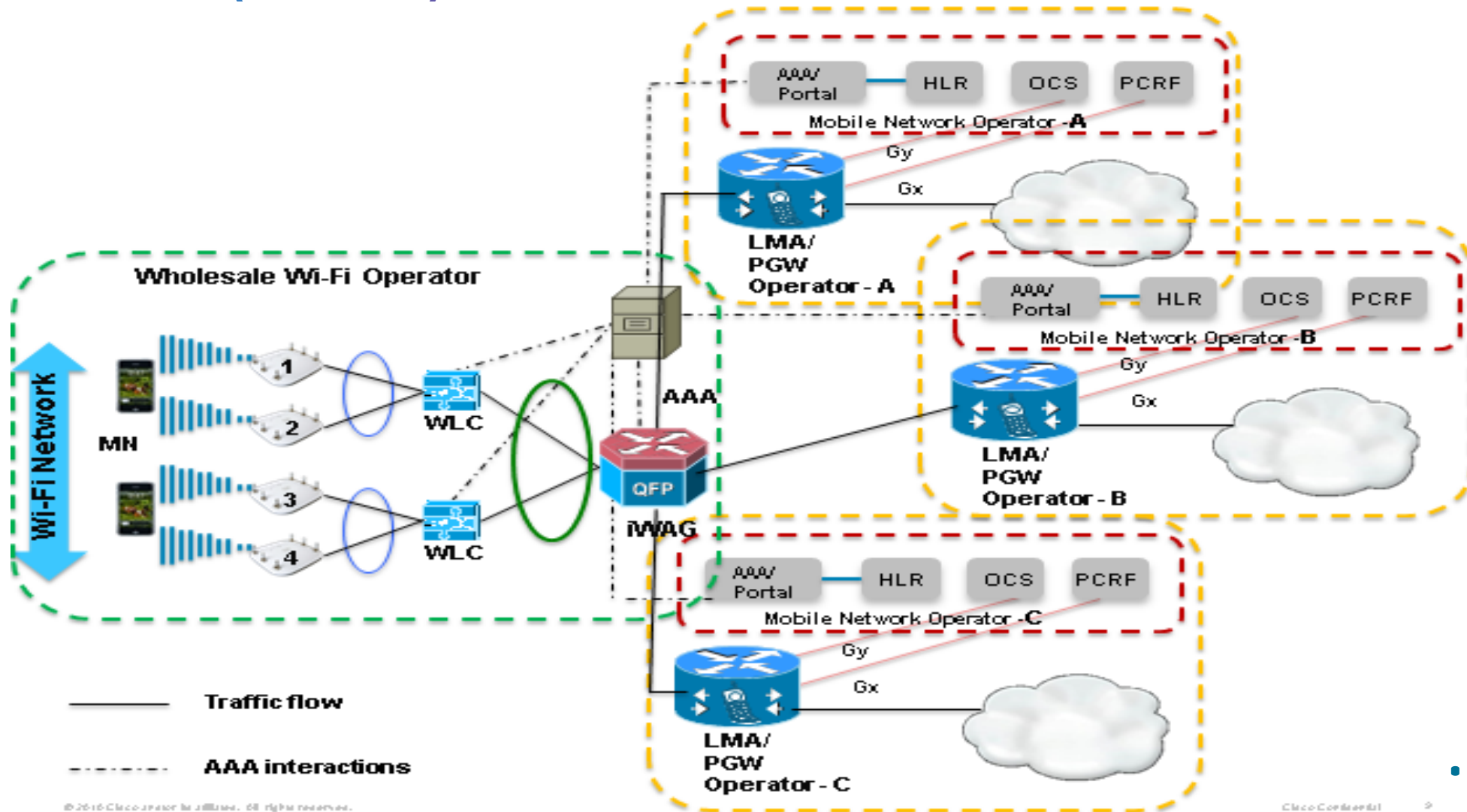

Residential & Community Wi-Fi

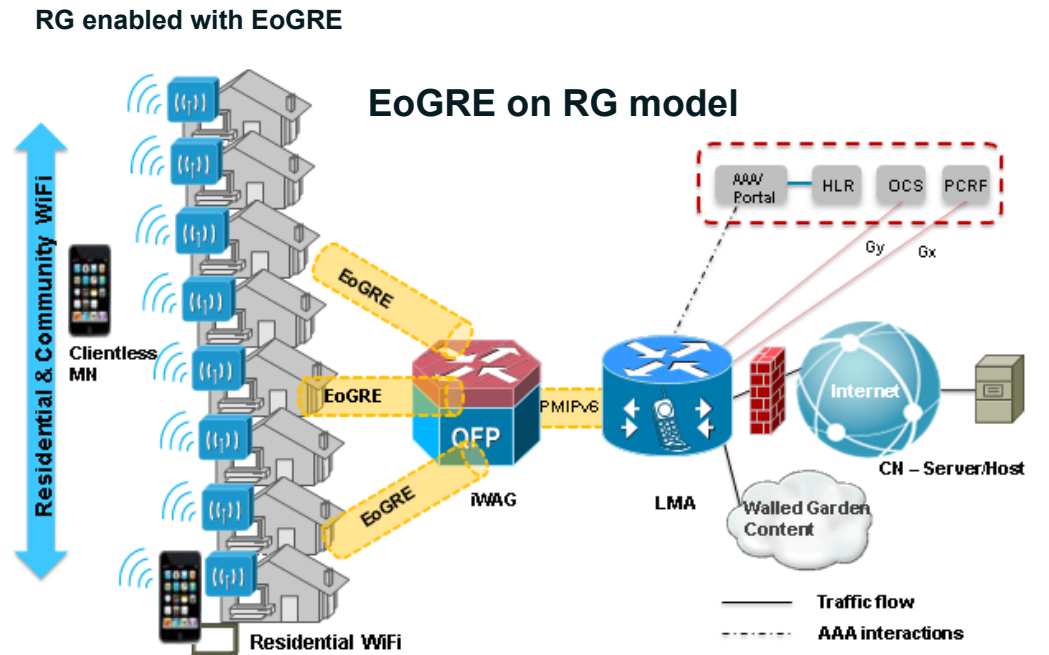
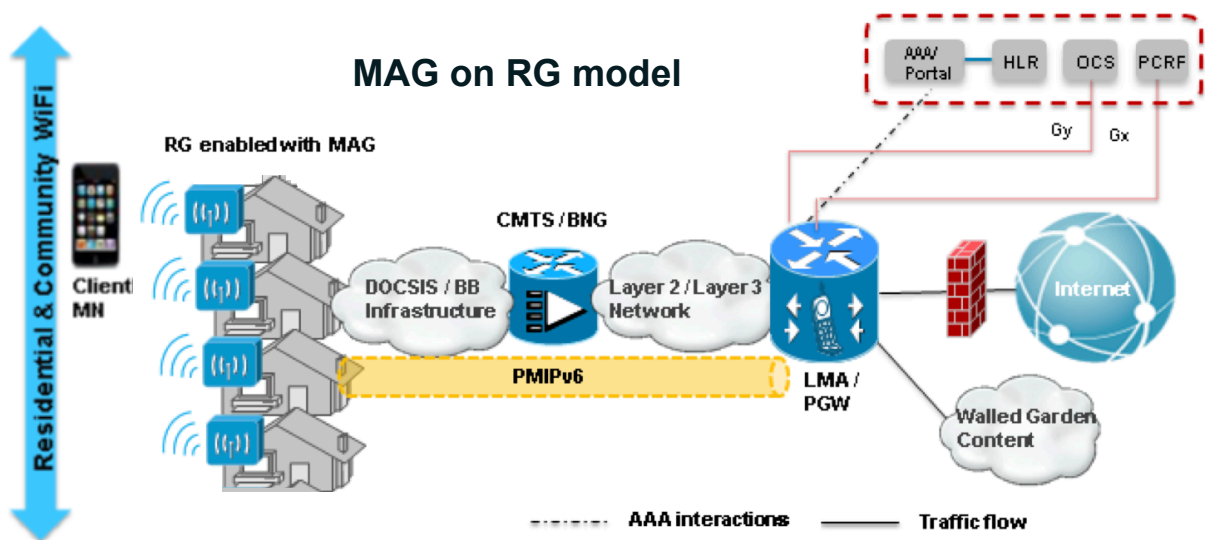
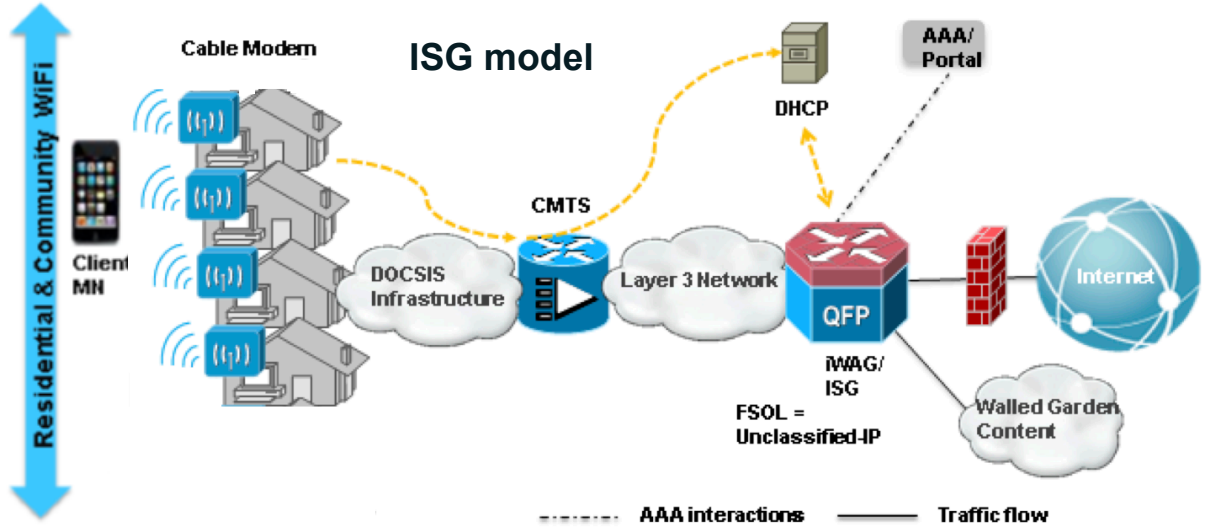

Untrusted Access for mobile Offload

3GPP I-WLAN overlay model

- User selects open SSID and associates with Wi-Fi
- Authentication is done via a EAP-SIM/AKA over IKEv2
- User device establishes IPsec TTG, PDG or ePDG
- GTP or PMIPv6 provide network based mobility
- GGSN/PDG/PGW provides access to mobile Internet services & enforces policies

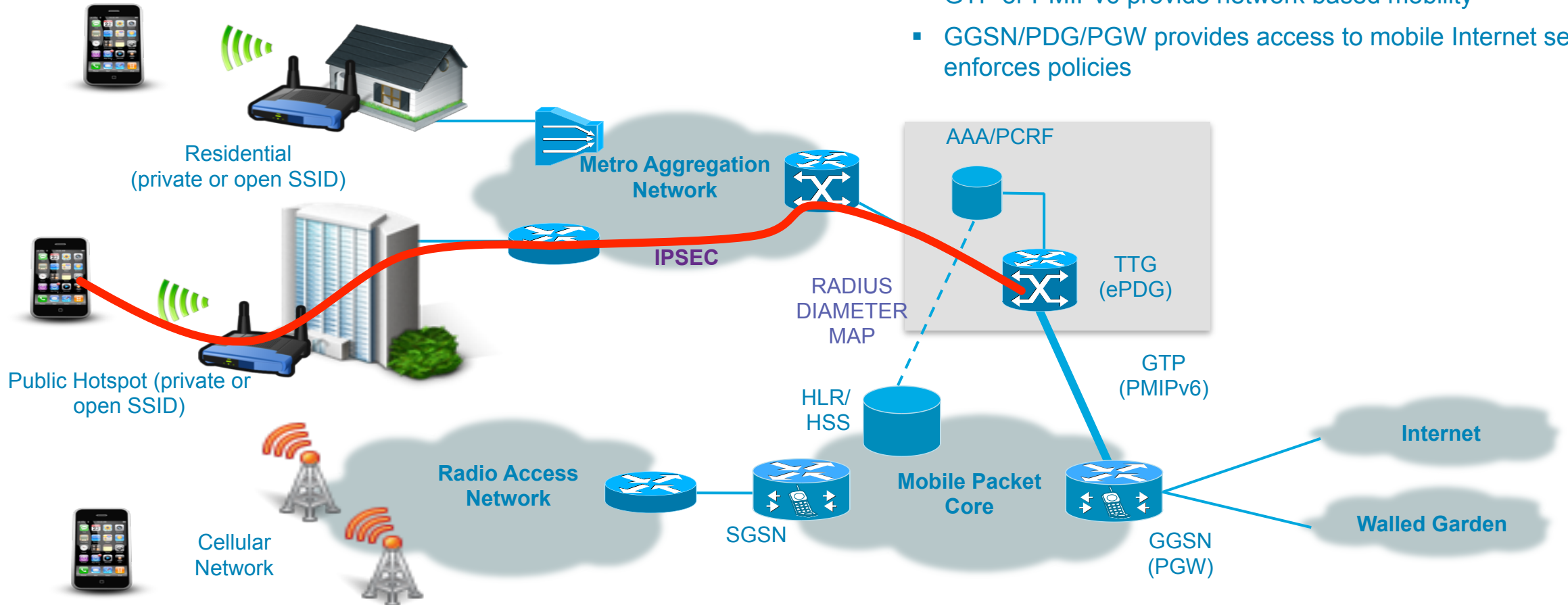

Agenda



From 2G to 3G

Introducing LTE

Femtocells

WLAN standards update

Improving Wi-Fi User Experience

Interfacing Wi-Fi with Mobile

Network Discovery and Selection for Mobile

Future Outlook and Summary

Motivation for Intelligent Network Access Selection

Access Selection Status Today

Networks are becoming more complex

- Mix of licensed and unlicensed access technologies

UE driven

- Dependent on OEM implementation and/or connection manager

User controlled

- User selects when/if to connect to WiFi

No operator input possible to access selection

- Service provider has no mechanism to help UE select access

How it should look like

Load balancing is needed across access types

- Based on loading info and network quality

Access selection has to be intelligent

- Network controlled rather than left up to the device/user
- Based on variety of criteria – location, time of day, service profile, device type, application

User experience needs to be the best

- The choice of best access network maybe different depending on a set of dynamic conditions

Cisco Access Policy Control (c-ANDSF)

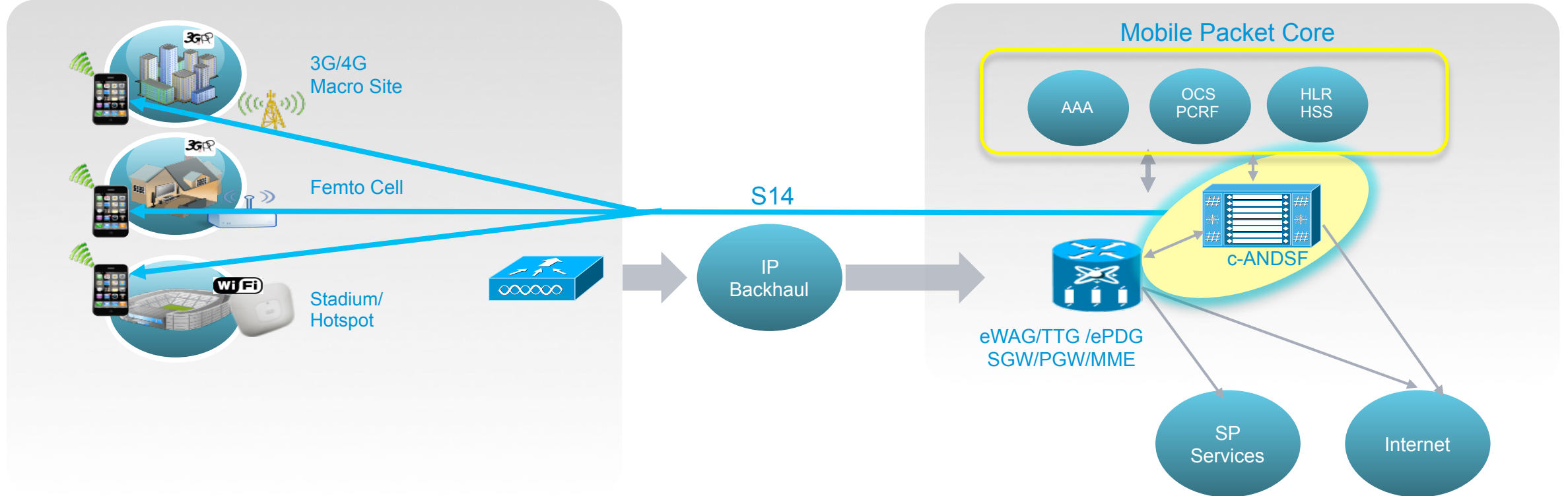

c-ANDSF

- Interfaces to network nodes to obtain information about the user profile and dynamic network conditions
- Constructs policies based on user profile, session status and dynamic network updates
- Dynamically pushes policy updates based on network triggers.
- Simple policies based on location, time of day, user status and available networks
- c-ANDSF receives data from the device and distributes it accordingly.

Agenda



From 2G to 3G

Introducing LTE

Femtocells

WLAN standards update

Improving Wi-Fi User Experience



Interfacing Wi-Fi with Mobile

Network Discovery and Selection for Mobile

Future Outlook and Summary

Network 2011

 3G Macrocell

 2100 MHz (1) – 1st carrier
 2100 MHz (2) – 2nd carrier

Limited to 7 macrocells
within 1x1km area

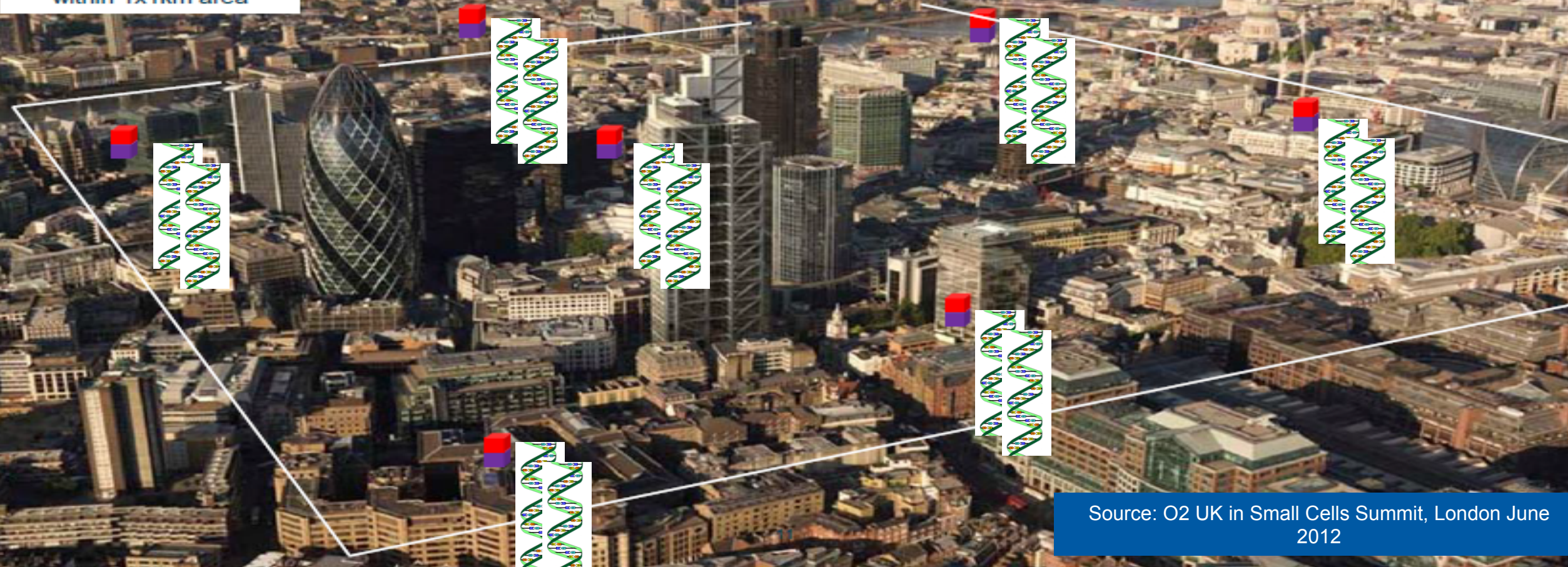

Source: O2 UK in Small Cells Summit, London June 2012

Network 2015



Macrocell

Microcell



Picocell

2100 MHz (1)

900 MHz (1)

2100 MHz (2)

900 MHz (2)

800/1800/2600 MHz

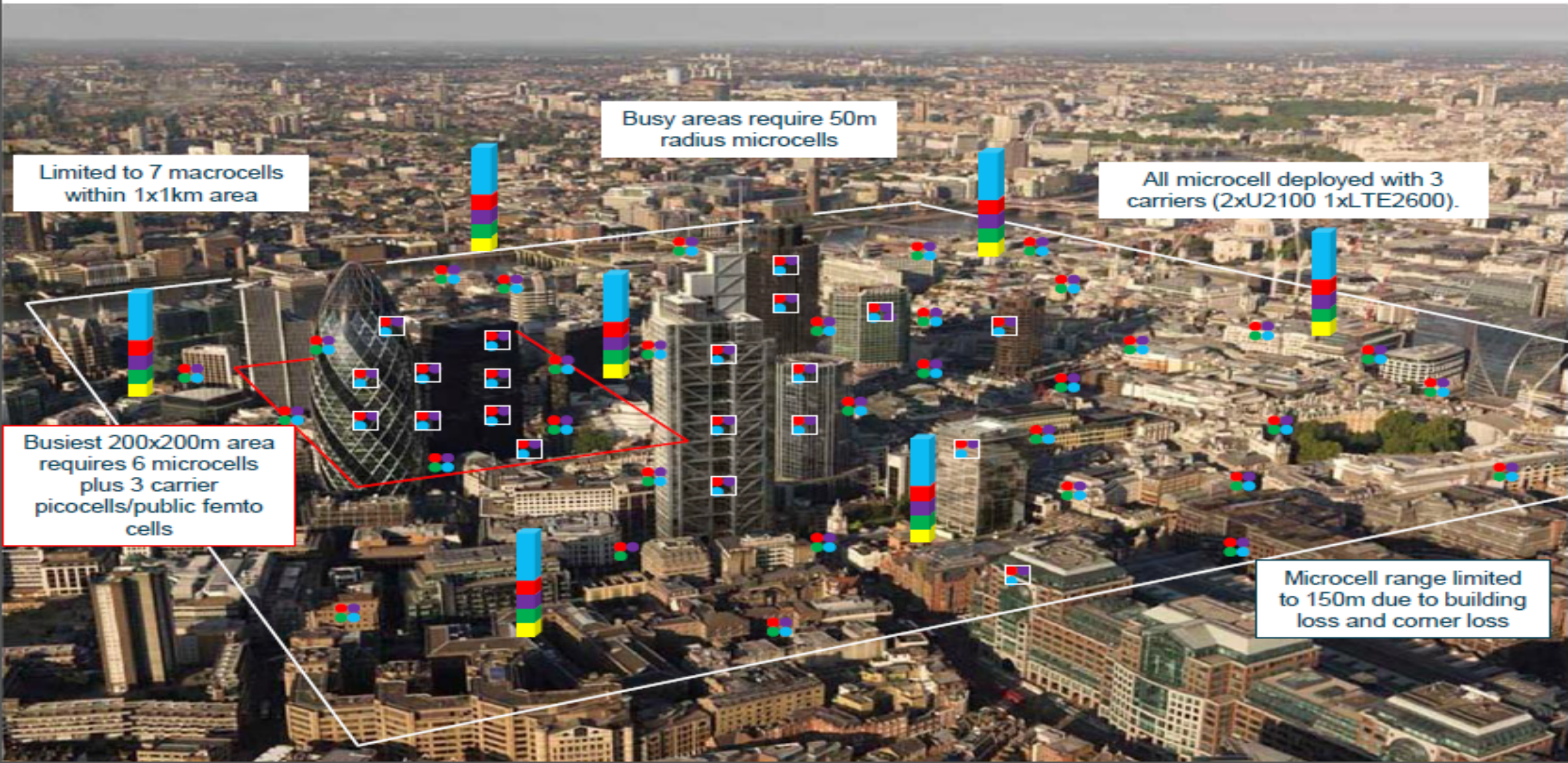

Busy areas require 50m radius microcells

Limited to 7 macrocells within 1x1km area

All microcell deployed with 3 carriers (2xU2100 1xLTE2600).

Busiest 200x200m area requires 6 microcells plus 3 carrier picocells/public femto cells

Microcell range limited to 150m due to building loss and corner loss

The Closed Loop That Builds Value

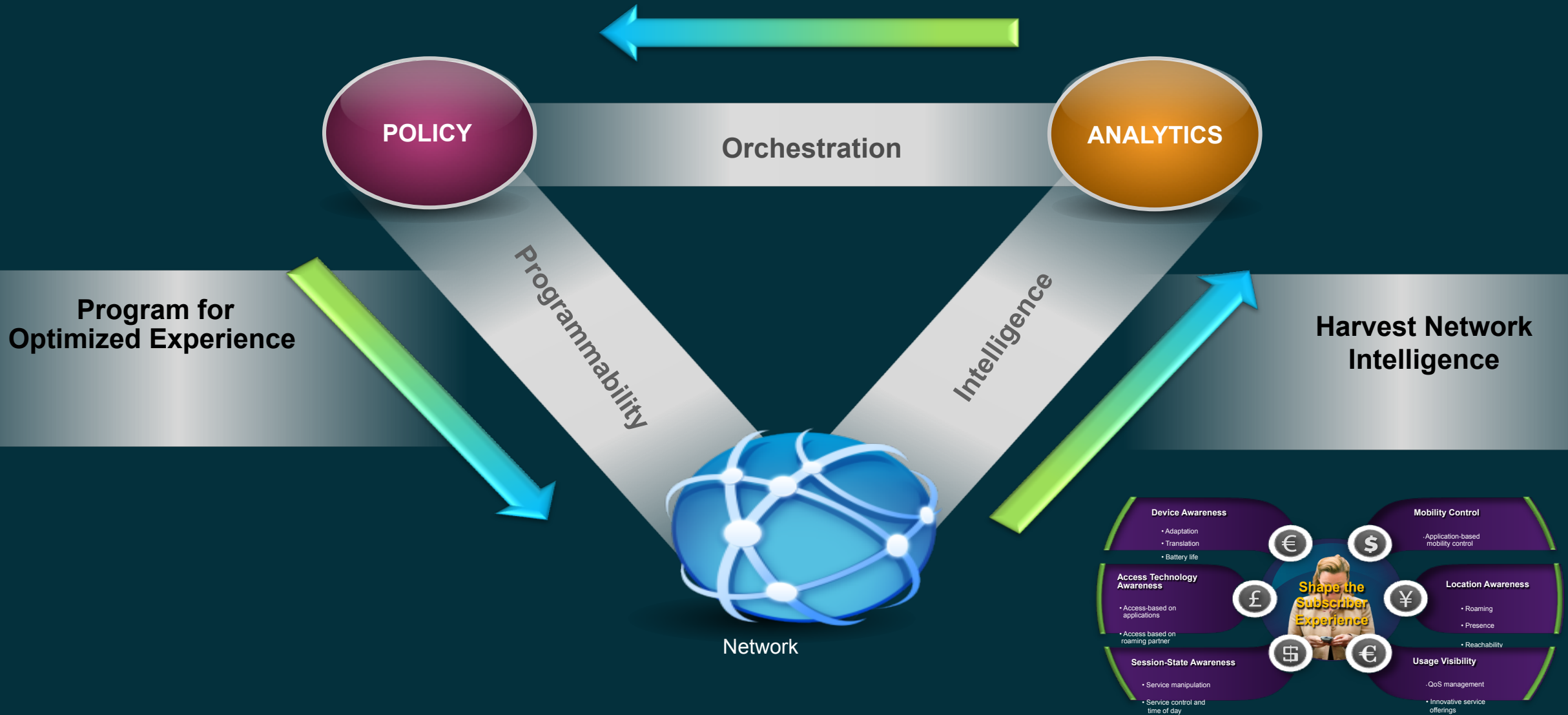

Putting it All Together: Congestion Management Use Case



Deny OTT Voice Calls (Policy and ASR5K)

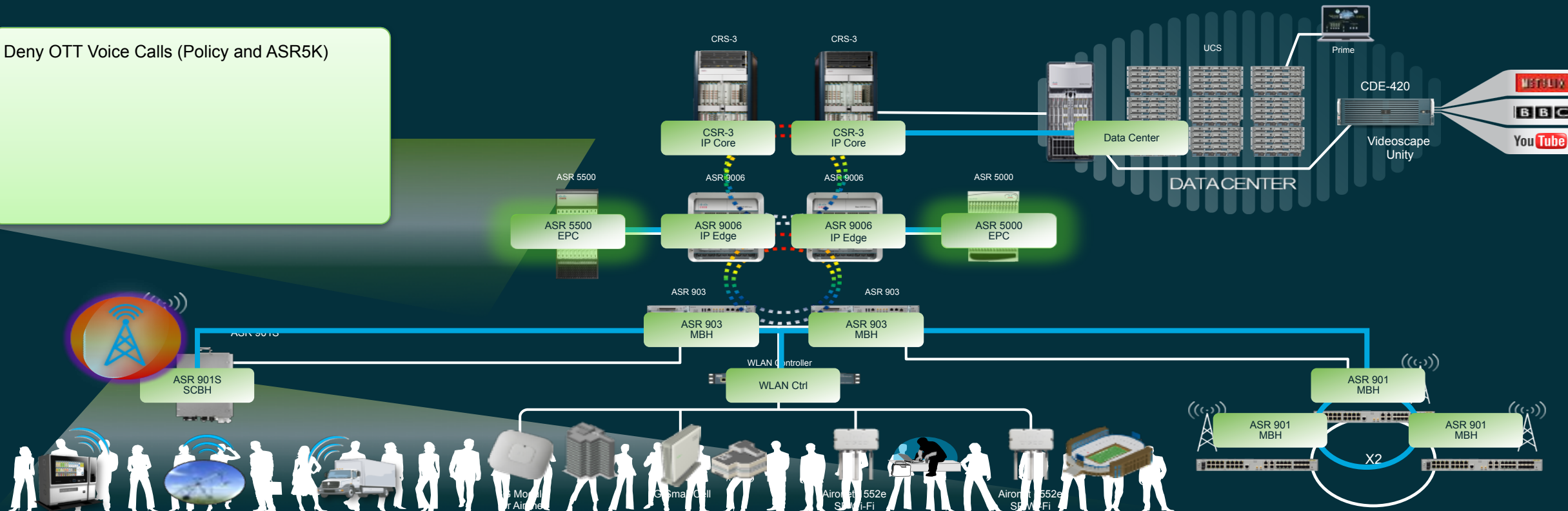

Summary

- Modern Mobile Architectures are IP based end-to-end
- Future Mobile Networks will use Small Cells in large scale
 - Femtocells
 - SP Wi-Fi
- Future Networks will be Programmable
 - Intelligence based on analytics
 - Combining Operator Policy
- Cisco has rich portfolio of relevant products and solutions
 - Mobile Packet Core based on ASR5000
 - SP Wi-Fi solutions, including Mobile Wi-Fi offload
 - Outstanding Radio Performance and industry leading Wi-Fi and Femto APs
- Cisco has Year of experience in Mobile and SP Wi-Fi

Otázky a odpovědi

Zodpovíme též v “Ptali jste se” v sále LEO v 17:45 – 18:30

e-mail: connect-cz@cisco.com

Prosíme, ohodnotte
tuto přednášku.

Thank you.

