



Connected Home 12:30-13:30

Josip Zimet





Connected Home, Connected Life

12:30-13:30

Josip Zimet



1986 1987 1988 1989 1990 1991 1992 1993 1994 1995 1996 1997 1998 1999 2000 2001 2002 2003 2004 2005 2006 2007

CISCO SYS INC

Splits: ▼
as of 19-Mar-2008

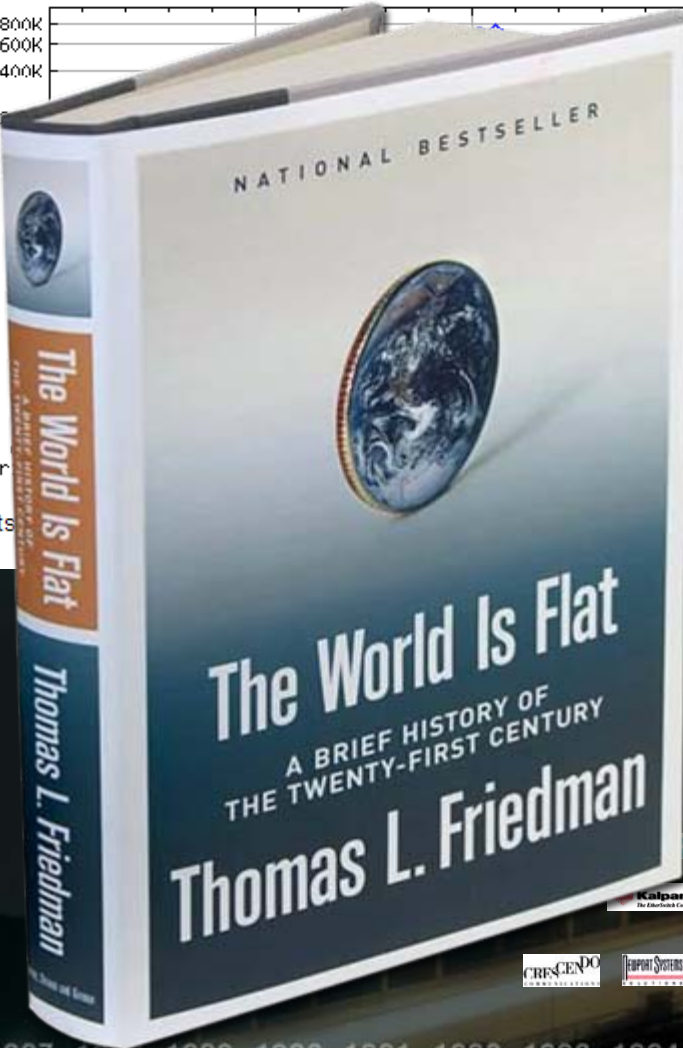

finance.yahoo.com/
[1], 20-Feb-96 [2:1],
[00 [2:1]

1986 1987 1988 1989 1990 1991 1992 1993 1994 1995 1996 1997 1998 1999 2000 2001 2002 2003 2004 2005 2006 2007

2003 2005 2007

LINKSYS **SIPURA** **Scientific Atlanta** **webex**

Ki|S|S

Scientific Atlanta

Ki|S|S

LINKSYS **SIPURA**

LINKSYS SIPURA Scientific Atlanta webex

Metaplex

Selsius Systems

Clarity Wireless



Top 5 Gadgets 2007



By Maryanne Murray Buechner

1



**Apple
iPhone**

2



**Nikon
Coolpix
S51c**

3



**Netgear
SPH200W
Wi-Fi**

4



**Palm
Centro**

5



**Sony
Handycam
HDR-CX7**

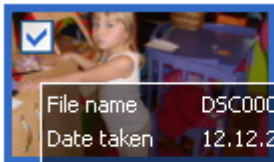

File name	DSC00001.JPG
Date taken	12.12.2007 18:50:47
Image size	2848 x 1602
Size	1,65 MB

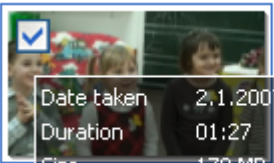

Date taken	2.1.2007 0:03:23
Duration	01:27
Size	170 MB

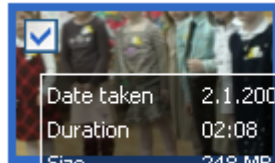
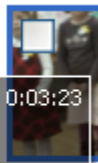

Date taken	2.1.2007 0:05:10
Duration	02:08
Size	248 MB

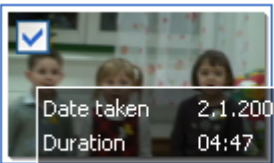

Date taken	2.1.2007 0:08:23
Duration	04:47
Size	554 MB

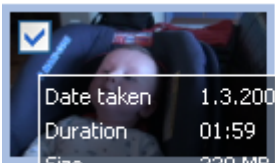
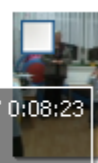

Date taken	1.3.2008 9:45:25
Duration	01:59
Size	229 MB



iPhone Software Roadmap

See what's ahead for developers, enterprise users, and you.

iPhone Software Development Kit

Get the tools you need to build your own iPhone applications.

[Learn more ▶](#)



iPhone Enterprise Beta Program

Test pre-release iPhone software with enterprise features in your workplace.

[Apply now ▶](#)



Microsoft Exchange ActiveSync support.

If your office uses Microsoft Exchange Server 2003 or 2007, iPhone 2.0 software will allow you to wirelessly push company email, calendar events, and contacts over Wi-Fi or EDGE networks to iPhones. With secure push email and over-the-air contacts and calendar features, users will stay up to date wherever they go. And thanks to the iPhone Multi-Touch display, users will find it easier to perform common tasks such as accepting meeting invitations and finding contacts in the company directory or Global Address List (GAL).



Enterprise-grade networking.

iPhone 2.0 software supports Cisco IPsec VPN to ensure the highest level of IP-based encryption for transmission of sensitive company information. Employees will be able to authenticate via password, two-factor token, or digital certificate. iPhone will also support WPA2 Enterprise with 802.1x authentication — the standard for Wi-Fi network protection. These features help provide safe access to sensitive company information on iPhone.



IT administrators can securely manage any iPhone that contains confidential company information with remote wipe and enforced security and password policies. These device configuration and remote management capabilities allow IT departments to quickly and seamlessly deploy iPhone throughout their companies.

Boosting Apple's New iPhone Capabilities—and the Power of the Network

CEC Posting Date: 2008-Mar-12



Apple recently announced that it will incorporate Cisco IPsec VPN technology in its iPhone 2.0 software release.

Workers are becoming more mobile, demanding greater access to their company's critical business applications and sensitive information wherever they are in the world. Smartphones have become an increasingly important business tool for accessing this information any place, any time.

Apple Inc. recently announced that it will incorporate Cisco IPsec VPN technology in its iPhone 2.0 software release to address this growing need. Cisco IPsec VPN builds secure connections between mobile corporate employees and their corporate networks by creating end-to-end, encrypted VPN tunnels.

While the level of VPN services on the existing iPhone provides basic services, it does not meet the connectivity, scale, and flexibility needed by customers in the enterprise market. Cisco IPsec VPN enhances the iPhone by providing "enterprise-class" VPN services, enabling integration into existing corporate security policies and, therefore, easing iPhone integration into the network.

This technology integration by Apple and Cisco is the result of a nine-month collaboration between the companies. This integration will help Apple enter the enterprise, which is a new market for Apple—and will help Cisco boost the awareness of the power of the network worldwide.

Increasing the Value of the Network

Apple last week released beta software loaded with Cisco IPsec VPN and other enterprise features that are specifically intended for enterprise customers and application developers. The move into the enterprise market could propel Apple past its goal of selling 10 million iPhones by 2009.

"This move will benefit Cisco as well," says Richard Palmer, SVP of Cisco's Security Business Unit. "Cisco's 1.5 million VPN gateways are the most highly deployed VPN solution in the world, and provide seamless and secure access to critical applications and data worldwide. Our presence in iPhone 2.0 is an opportunity to increase the value and power of the network through millions of new iPhone users."

The Cisco logo will be a soft key on the iPhone screen in its secure enterprise access menu and, according to Palmer, could create greater brand awareness and recognition for Cisco among iPhone users.

Corporate Support and Trials of the iPhone



Cisco IT Analyst Alan Kauth (right) tests the early enterprise iPhone code with an Apple iPhone product developer pre-launch.

Will Cisco IT support the iPhone for employees now? Not right away, says Chuck Trent, vice president of IT Global Client Services and Operations. However, Cisco and Apple are discussing the requirements for Cisco IT to participate in customer trials.

"It's exciting to see Cisco and Apple working closely together and embedding technology for the enterprise natively into smartphones," Trent says. "We know the release of enterprise functionality will be greeted enthusiastically by many iPhone owners in Cisco, and we are keen to understand its potential use within our enterprise."

When the Apple beta trials are completed in late June, Cisco IT and the business units will assess the service provider cost impact and value of the iPhone functionality, and will determine the best deployment strategy at Cisco. Trent says the assessment should be completed by June 30, and the trial results will be posted on Cisco's IT Mobility Website when they are under way. Until the evaluation is complete, he cautions, iPhones will continue to be an unsupported, out-of-policy device for Cisco employees.

"Long term, this sort of industry collaboration definitely makes our jobs easier in IT," Trent says. "And it moves us closer to the Cisco vision of being able to use any device."

More Collaboration Ahead

This is not the first time Apple and Cisco have collaborated. Cisco VPN technology resides in Apple platforms such as the Macintosh. After the iPhone trademark issue of February 2007 was resolved, Palmer says, Cisco and Apple regained mutual trust and began to explore new opportunities. "We continue to explore opportunities in security and in consumer and enterprise communications," he adds.

iPhone Enterprise Customer Beta Program

If you have a customer that expresses interest in the iPhone Enterprise Beta Program, please refer them here to the [Apple Website](#). All customers will be required to fill out an online application. Currently, only U.S.-based companies are eligible to apply for the program.

Need for the Connected Home

- **Consumers are migrating to digital applications to enjoy new experiences and benefits**
 - Digital photos, music, video, communications (IM, VoIP)
- **Migration creates new usability challenges**
 - Content stored on many, isolated devices
 - Devices are difficult to setup and connect together
 - Key challenge: find, share, and play content wherever you want it – usually on a different device than where it's stored

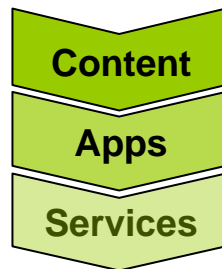

Consumer 5 Phase Plan

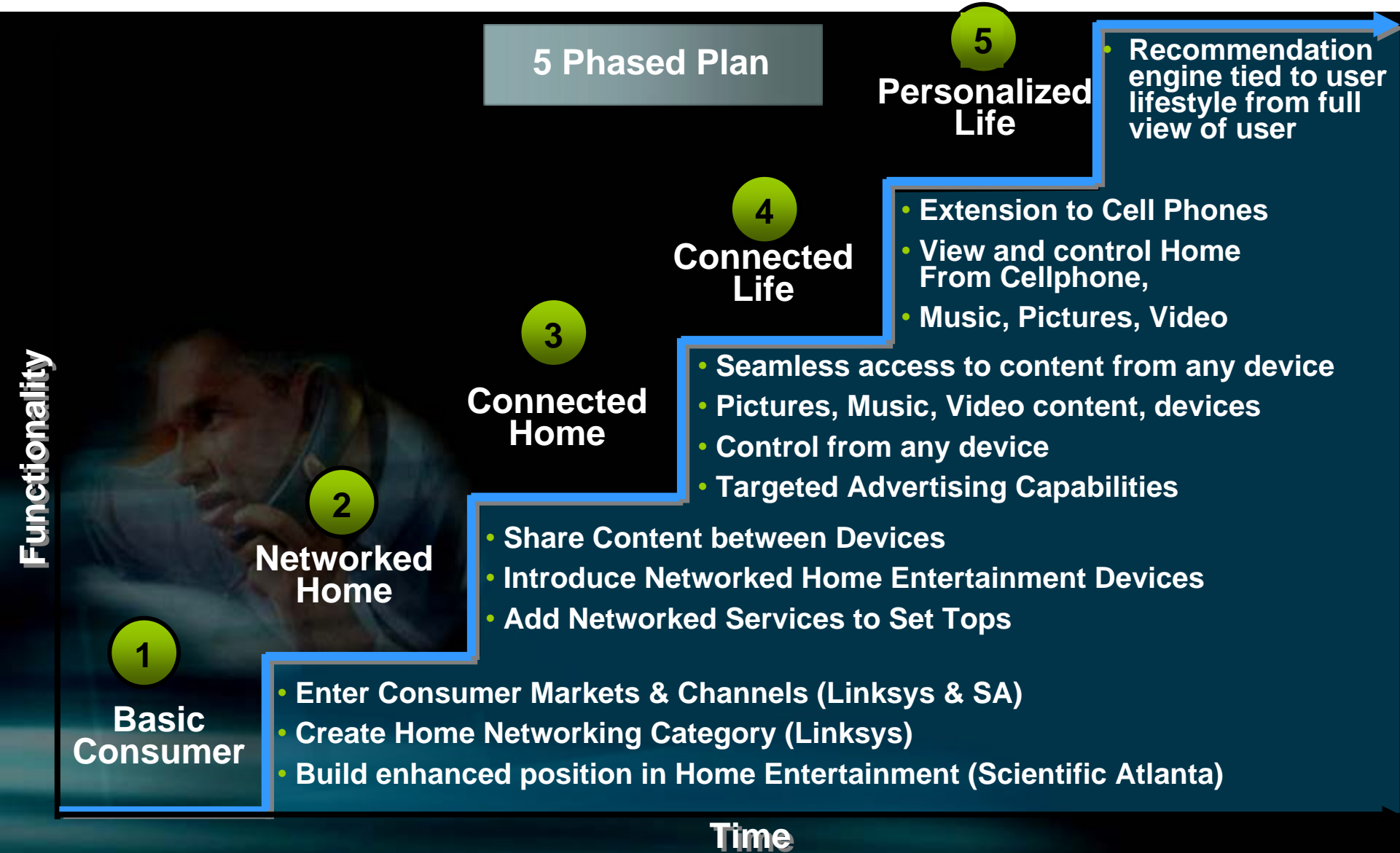

Consumer Connected Life Experiences

Phase 1 Personal Media Sharing 2008

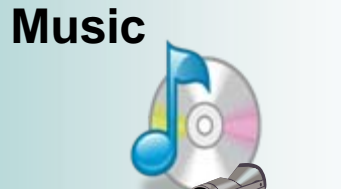

Phase 2 Whole Home Sharing 2009



Integrated
Triple
Play



Phase 3 Connected Life 2010



Integrated
Quad
Play



Technologies

DLNA

SIP

QOS

UPnP

Resource Pooling

MoCA

HPNA

PowerLine

UWB

Transcoding

EGHN

Resource Management

Connected Home Architecture

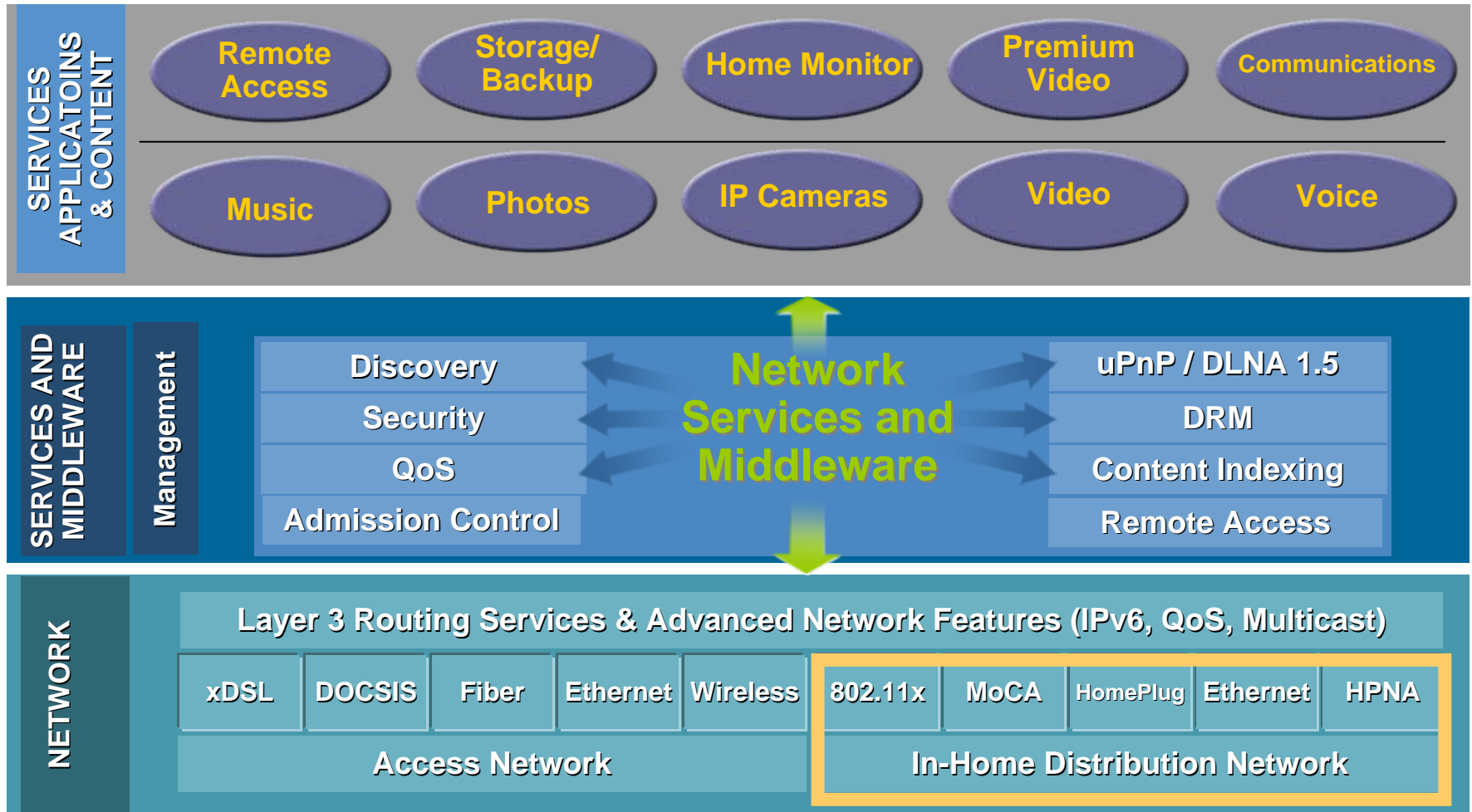

End to end IP-TV & connected home solution

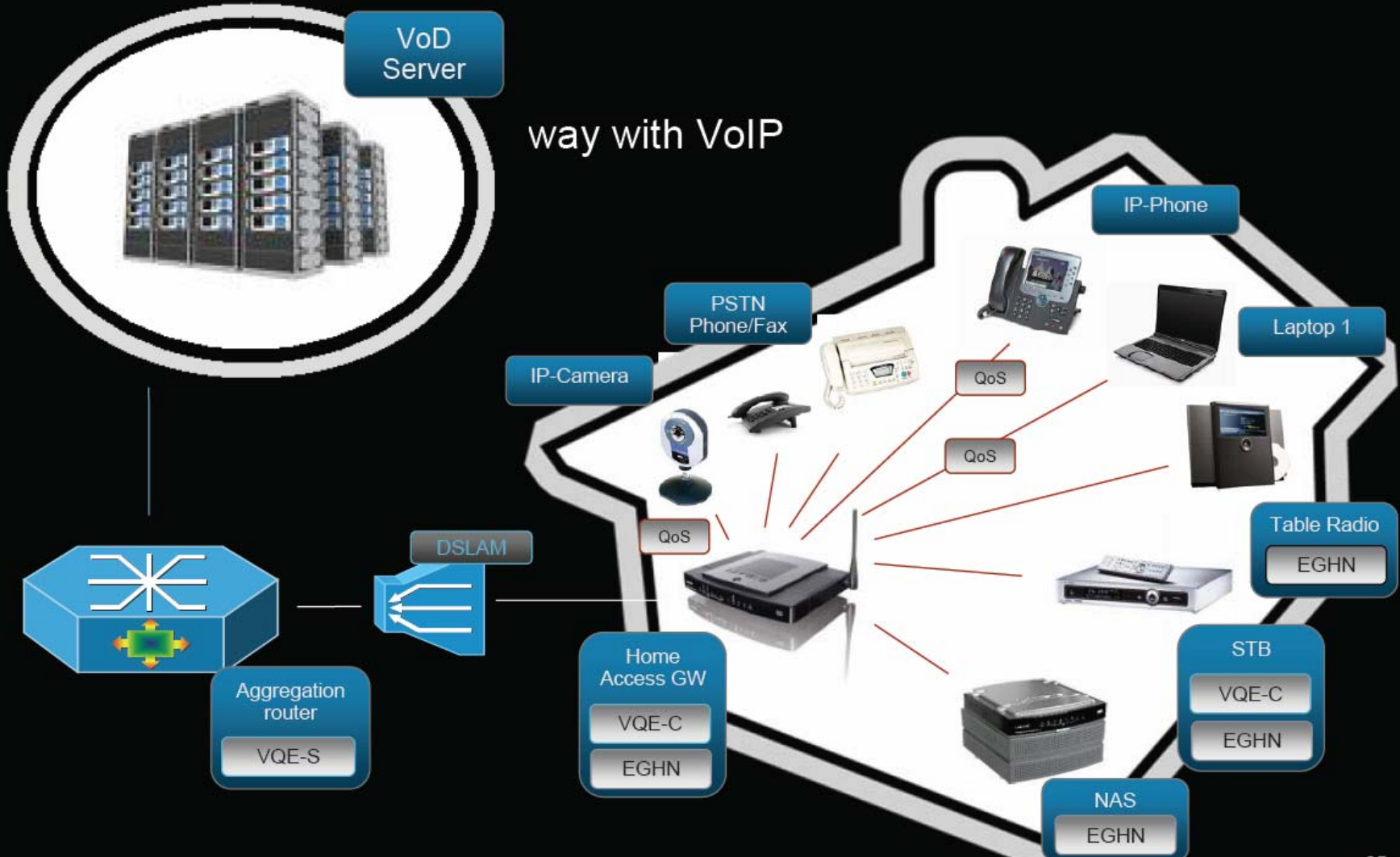

SP Concerns in Quality of IPTV Services



1% packet Loss

5% packet Loss



Packet Loss example for Telepresence

- *One-Way, End-to-End Service Level Targets*

–Latency \leq 150 ms

–Jitter \leq 10 ms

–Loss \leq 0.05%

- *Average Packet Size / Packets per Second*

–Average 1100 bytes / packet

•CTS-1000 @ 5.5 Mbps = average 655 pps

•CTS-3000 @ 15.3 Mbps = average 1,740 pps

	1080p	CTMS at 1080p (32x)	720p	CTMS at 720p (32x)
CTS-1000	4,3-5,5 Mbps	198 Mbps	2-4,3 Mbps	154,8 Mbps
CTS-3000	11,7-15,3 Mbps	550,8 Mbps	4,5-11,7 Mbps	421,2 mbps

Displays



Microphones



Environmentalals



Camera

Codec

Furniture

My Inbox over the years

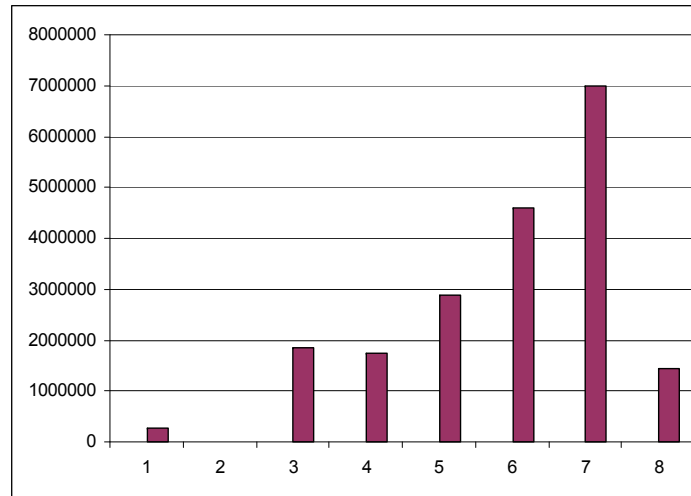

2001.pst	269.841 KB	Office Data File	26.3.2008 10:37
2002.pst	1 KB	Office Data File	1.12.2007 0:42
2003.pst	1.841.169 KB	Office Data File	26.3.2008 10:37
2004.pst	1.728.081 KB	Office Data File	26.3.2008 10:37
2005.pst	2.894.673 KB	Office Data File	26.3.2008 11:07
2006-1.pst	2.799.441 KB	Office Data File	26.3.2008 10:37
2006-2.pst	1.815.377 KB	Office Data File	26.3.2008 10:37
2007-1.pst	2.388.753 KB	Office Data File	26.3.2008 10:37
2007-2.pst	2.303.441 KB	Office Data File	26.3.2008 10:37
2007-3.pst	1.279.697 KB	Office Data File	26.3.2008 11:13
2007-4.pst	1.013.841 KB	Office Data File	26.3.2008 10:37
2007.pst	265 KB	Office Data File	2.6.2007 23:02
2008.pst	1.434.449 KB	Office Data File	26.3.2008 11:22

4594818

6985997

VSEARCH ... 16 Virtual teams/2 events per year

The screenshot displays the Cisco vSearch interface. At the top, the Cisco logo is on the left, and 'Worldwide Sales Enablement vSearch' is in the center. A navigation bar includes 'HOME', 'MY VSEARCH', and 'MY PR'. A secondary navigation bar features icons for 'RoD', 'VoD', 'MP3', 'MP4', and other media types. On the right, it shows '18 users currently logged in' and links for 'Preferences', 'Support / Feedback', 'TUTORIAL', and 'RSS'.

The main content area shows search results for 'SP SERVICES AND APPLICATIONS VT - JUNE 2007'. A search sidebar on the left includes a search box, filters for 'Search Using' (All Words), 'Search Within' (Current Event), and 'Display Options' (Presentations). A 'BROWSE' sidebar on the left lists various categories like 'SEVT - SE Virtual Team (259)', 'CSA / DxE (2)', 'Ent Routing & Switching (29)', etc.

The search results are displayed in a table format:

File Name	Size	Format
a&s nov 07 ARTGUpdate_04sladden_ipod_mp4.mp4	28.798 KB	MPEG-4 Movie
a&s nov 07 BTSUpdate_01shah_ipod_mp4.mp4	38.102 KB	MPEG-4 Movie
a&s nov 07 CASConditionalAccessSystemDRM_21goldberg_ipod_mp4.mp4	37.593 KB	MPEG-4 Movie
a&s nov 07 CDSApplications_19cruz_ipod_mp4.mp4	33.815 KB	MPEG-4 Movie
a&s nov 07 CiscoSBCCubeProductUpdate_05sladden_ipod_mp4.mp4	50.906 KB	MPEG-4 Movie
a&s nov 07 ConnectedHomeArchDeepDive_15visser_ipod_mp4.mp4	33.232 KB	MPEG-4 Movie
a&s nov 07 DSCDSDeepDive_20dasu_ipod_mp4.mp4	18.439 KB	MPEG-4 Movie
a&s nov 07 DS IPTVHEDesign_16martinez_ipod_mp4.mp4	44.609 KB	MPEG-4 Movie
a&s nov 07 ISDP Services Layer_22briggs_ipod_mp4.mp4	30.132 KB	MPEG-4 Movie
a&s nov 07 ManagedServices_13blatnik_ipod_mp4.mp4	26.841 KB	MPEG-4 Movie
a&s nov 07 MCPOverviewandNGNIinsertion_14kumar_ipod_mp4.mp4	27.827 KB	MPEG-4 Movie
a&s nov 07 MobilityUpdate_07gera_ipod_mp4.mp4	28.567 KB	MPEG-4 Movie
a&s nov 07 NumberPortabilityNP_03beumer_ipod_mp4.mp4	28.784 KB	MPEG-4 Movie
a&s nov 07 OTTVideoImpactinServiceProviders_10defour_ipod_mp4.mp4	30.522 KB	MPEG-4 Movie
a&s nov 07 PGWUpdate_02vandelde_ipod_mp4.mp4	27.825 KB	MPEG-4 Movie
a&s nov 07 TISPANIMSSowhatdowereallyhavetosell_08evans_ipod_mp4.mp4	33.030 KB	MPEG-4 Movie
a&s nov 07 UnifiedCommunicationsforServiceProvider_06aguayo_ipod_m...	21.357 KB	MPEG-4 Movie
a&s nov 07 VideoDeploymentServicesCiscoCASASciCare_17wellen_ipod_m...	25.069 KB	MPEG-4 Movie
a&s nov 07 VQE_18kernen_ipod_mp4.mp4	28.575 KB	MPEG-4 Movie

Below the table, a specific result is highlighted: 'SP Business Update' by Michael Koons, dated 04-Jun-2007, with a duration of 00:40:33 and 9 slides. It includes a star rating and links for 'Transcribed', 'Custom PPT', 'Comments/Questions (0)', and 'Related Resources (0)'. A 'PERMALINK' and 'RSS' icon are also visible.

Connected Home



Internet Audio Center



Digital Picture Frame



Home Phone System



Internet Media Server



Linksys NAS 200
Linksys NMS200



WAG 325N



LINKSYS KISS DP1600 £200

THIS IS A pretty simple device. You connect the KISS to your TV and network, and it streams video, music and photos from your computer. It's easy to set up, and as a bonus it also plays DVDs, upscaling them to 720p or 1080i.

What makes this little beauty stand out from the streaming pack is its ability to carry Hi-Def video via HDMI or component. You can burn HD material to disc and play it that way, but we managed to get crisp 720p footage streaming seamlessly over the KISS's built-in Wi-Fi. An ethernet connection would be even more reliable.

In short, it's rather like Apple TV, without the onboard storage but with many of the best usability and an appealing DVD player nailed to its face. Nice work, Linksys.

T5 ★★★★★

WE SAY A nice compact Hi-Def streamer that works beautifully but costs very little.



IP STB



Universal Plug And Play

Garage Device Scenario

Upon clicking a garage door opener remote when returning home, all related devices including heating and cooling, entertainment, appliances and others are automatically set to "house occupied" status.

UPnP™ is a certification mark of the UPnP™ Implementers Corp.



Kid's Bedroom Device Scenario

After completing homework, the kids enjoy voice, video and text instant message conversations and multi-player games with friends on their PC over a shared Internet connection across the home network.

UPnP™ is a certification mark of the UPnP™ Implementers Corp.

Master Bedroom Device Scenario

At bedtime the blinds close, the lights turn off, and the security system is set.

UPnP™ is a certification mark of the UPnP™ Implementers Corp.



Kitchen Device Scenario

Listen to a collection of digital streamed music while preparing a meal, run the dishwasher when electricity prices are lowest, and track grocery needs on the refrigerator control panel then download the list to a wireless PDA.

UPnP™ is a certification mark of the UPnP™ Implementers Corp.

Living Room/Dining Room Device Scenario

Watch videos on a home theater system or enjoy digital music played through a home audio system with content stored elsewhere in the home or streamed across the Internet. In preparation for dinner, the blinds are closed, the lights adjusted to a preset level, the phone is set to do-not-disturb and favorite digital photographs of family or friends are queued on an electronic picture frame.

UPnP™ is a certification mark of the UPnP™ Implementers Corp.

Home Office Device Scenario

Automatically download the new photos from a digital camera to a PC, then print favorites with the touch of a button on a shared printer attached to the home network. Use the PC to control any UPnP™ certified device in the home and enable these devices to access digital music, video, or photo content stored on the PC.

UPnP™ is a certification mark of the UPnP™ Implementers Corp.

uPnP Expanded Services



New End-User Features (Require uPnP extensions)

- Playlist distribution
 - Ability share playlist w/ community of interest, and have home network serve up the content
 - A/V stream splitting
 - Ability to split the music from AV stream e.g. Music Video and send to music-only devices
 - Follow me services
 - Pause content on in-home device and continue watching on portable device
 - Mobile content synchronization
 - Offload pictures from mobile to home network when you are at home (or even in hotspot, or 3G)
-

New Network Capabilities (Require uPnP extensions)

- Ability to create home network resource pools for
 - Tuners
 - Transcoding, Transrating, Transcrypting
- Resource could be on any device e.g. STB, DMA, PC, and be available to any other device in the home

Watching home movies	Watching home movies	Watching home movies
Listening to music	Listening to music	Listening to music
Watching photo slideshows	Watching photo slideshows	Watching photo slideshows
Enjoying music on-the-go	Enjoying music on-the-go	Enjoying music on-the-go
Watching TV shows	Watching TV shows	Watching TV shows
Printing photos	Printing photos	Printing photos

Watching photo slideshows



You can't wait to show everyone the shot of your son's game-winning goal captured on your mobile phone. With a DLNA Certified phone, just send the pictures to your DLNA Certified TV to relive the goal in all its triumphant detail. Then send the photo over to your DLNA Certified network attached storage (NAS) for safe keeping.

Before DLNA: You would've been out of luck if you wanted to show your photo on anything other than your mobile phone's tiny screen.

Watching home movies	Watching home movies	Watching home movies
Listening to music	Listening to music	Listening to music
Watching photo slideshows	Watching photo slideshows	Watching photo slideshows
Enjoying music on-the-go	Enjoying music on-the-go	Enjoying music on-the-go
Watching TV shows	Watching TV shows	Watching TV shows
Printing photos	Printing photos	Printing photos

Printing photos



Your coworker just sent your phone a hilarious multimedia message photo of himself in Las Vegas. After sending the photo to your DLNA Certified TV to view it on a large screen, you know you have to share it with everyone at work. With DLNA Certified devices, just print the photo to your DLNA Certified printer, with a few simple clicks from your phone, and you can make copies for the whole office.

Before DLNA: The only way to print photos was to get them to the PC first. And good luck figuring out how to do that from your phone.

Vertical Integration Is the Key to Successful Internet–Television Convergence

[Digital Media Research Service](#) | [Home Networking Research Service](#) | [Digital Video Adapters in the Living Room](#)

► [email this page](#)

NEW YORK - January 25, 2008

Contact: Nicole Fabris

[Contact PR](#)

www.abiresearch.com

Early attempts to bring networked video to consumers' television screens have fallen far short of success, but that may change soon with the arrival of new vertically integrated solutions and business models, according to a recent study from ABI Research. Thus far, initial product offerings have been centered on a computing and home networking model; but vendors are learning that they need to provide end-to-end solutions in order to attract new consumers.

The Digital Living Network Alliance (DLNA) supports broad communication between networked devices and even handset manufacturers such as Nokia have shown how a Wi-Fi-enabled handset plays a role in the connected living room. Microsoft has been busy with its Media Center Extender technology, now repositioned as "Extender" technology for the Windows Media Center. Extender technology can be embedded in any suitable consumer electronics device, in addition to standalone DMA (Digital Media Adapter) clients, and is featured in products from both Linksys and D-Link, as well as the HP MediaSmart TV.

"While Extender defines a specific implementation, the more generic DLNA devices continue to gain widespread industry support," says ABI Research principal analyst Steve Wilson. "Today, however, these have less visibility at the consumer level."

But ABI Research believes that video is the big fish – and home networked-based approaches are beginning to take a back seat to efforts being made by companies that directly link Internet services with television. Leveraging their strong brands, companies such as Apple, Netflix, and TiVo are providing more vertically integrated solutions. At Macworld, Apple announced an upgrade for Apple TV, which allows consumers to rent movies directly from iTunes without going through a PC. The TiVo PVR now supports Amazon Unbox, allowing consumers to buy or rent from Amazon. In addition, Netflix and LG announced an agreement to work together – bringing Netflix movies directly to the living room via an LG client. In all probability, this client will be embedded in an existing LG product such as a TV, DVD player, or PVR.

Anywhere, Anytime Access and Sharing



- Remote Access to Content
- Content Distribution to Ecosystem of Devices
- EGHN to Ensure Quality of Experience

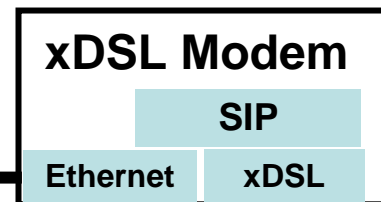
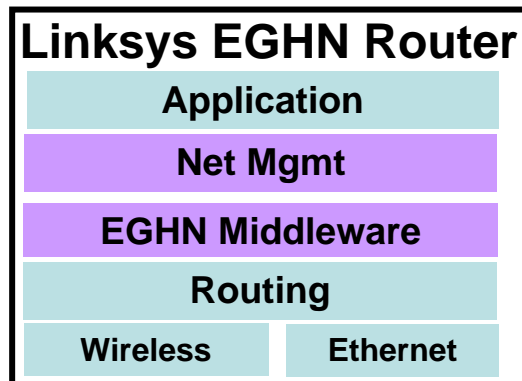
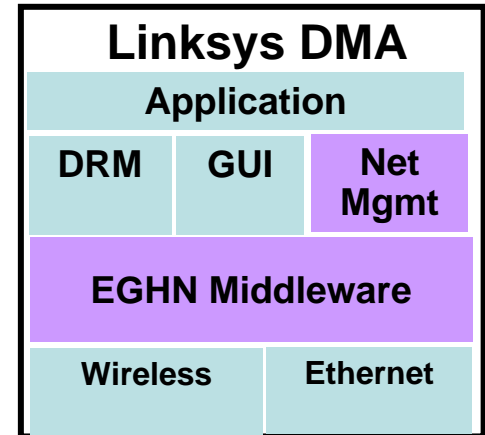
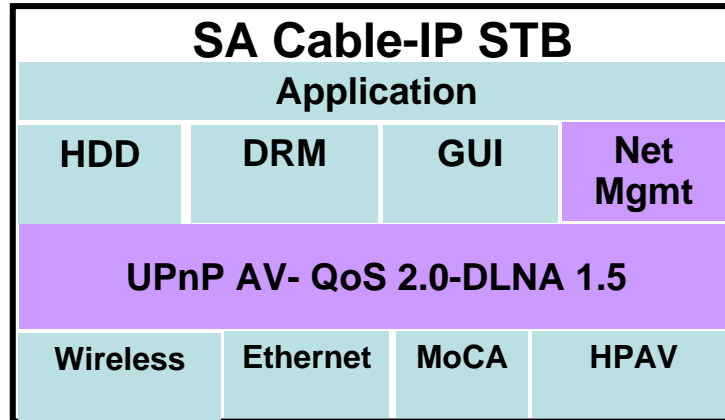
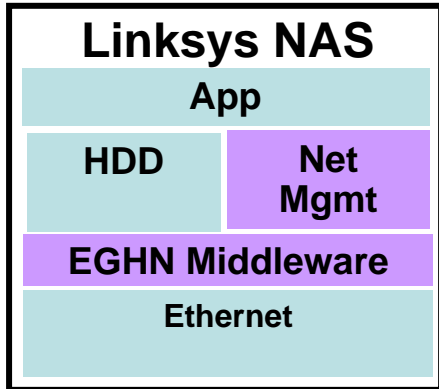

Nokia

Remote Access with Nokia Mobile Phones

- Nokia phones connects to your home network
- Via VPN or our Datacenter solution
- Via UPnP AV/DLNA 1.5 the phone will be able to gain access to you content on your devices
- We are now working on sync.
- Transcode –Transrate home content and more.

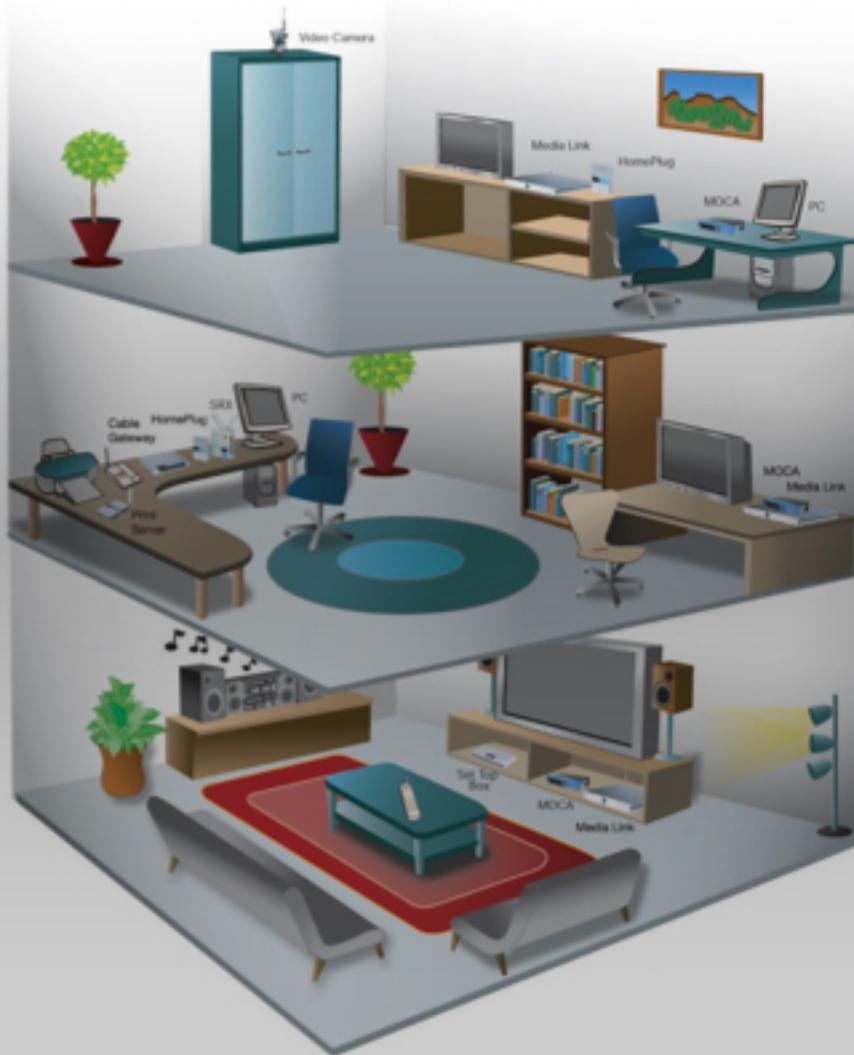

8%

power savings a unified fabric and I/O will deliver in the data center.

And this is how we built it.

<http://www.cisco.com/go/datacenter/dcan>



Products Solution Tests Methodology

Software Versions

Other “Connected Home” Media devices



Internet Audio Center

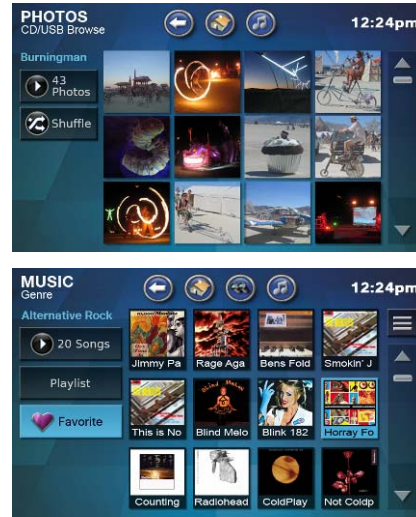

Internet Media Server



Digital Picture Frame



Home
Phone
System



Linksys NAS

- n configuration, single drive, dual, embedded disks, USB
- Scales > 1TB
- Security & Redundancy,
 - Raid 0,1
 - Client BackUp SW
- Media & Content Intelligence,
 - UPNP AV 2.0 Server
 - DLNA 1.5 Compliant

Release 2

- EGHN
- LLTD Server
- Microsoft DRM Server “Elvis”
- P2P download manager
- Transcode/ transrate in hardware

	Linksys NAS200	Linksys NMS 200 Release 1
Drive Bays	x2	x2
Drives	not included	320GB
Remote Access	HTTP, FTP	HTTP, FTP, Remote Access s/w
Setup Software	✓	✓
UPnP AV Server	DLNA 1.5	DLNA 1.5
Memory	32MB Flash 8MB	DDR2 128MB, Flash 8MB
10/100 (Ethernet)	✓	✓
1000 (GigE)		✓
USB	x2	x2
Backup Software	✓	✓
OS	Linux	Linux
JBOD	✓	✓
RAID0	✓ (2 Drives min.)	✓ (2 Drives min.)
RAID1	✓ (2 Drives min.)	✓ (2 Drives min.)
ASIC	RDC 3210 150MHz	Marvell 5182 400 MHz

- **WiFi**

- IEEE 802.11b/g
- 802.1x Authentication
- External RADIUS Authentication
- WPA2 and WPA Access
- WEP, AES and TKIP Encryption
- WPA/WEP Mixed Mode
- Wi-Fi Multimedia Support (WMM)
- Multiple SSIDs
- MAC Address Filtering
- WPS (Pushbutton and PIN Entry)
- U-APSD

- **Device Characteristics**

- 110-240VAC 50/60 Hz Switching Power-Supply; 12VDC, 2A Output
- LEDs: Power, Ethernet, WLAN, Phone, Line, DSL, Internet, USB
- Dimensions : 8.7" x 6.9" x 1.7" W x L x H (220mm x 175mm x 42mm)
- Unit Weight 0.9 lb. (0.4kg)
- Operating Temperature: 0 to +40C
- Desktop, wall mount
- Omni Directional External Antenna

- **ADSL Annex A**

- ADSL [ITU 992.1]; ADSL2 [ITU 992.3]; ADSL2+ [ITU 992.5] ANSI T1.413 Issue 2.

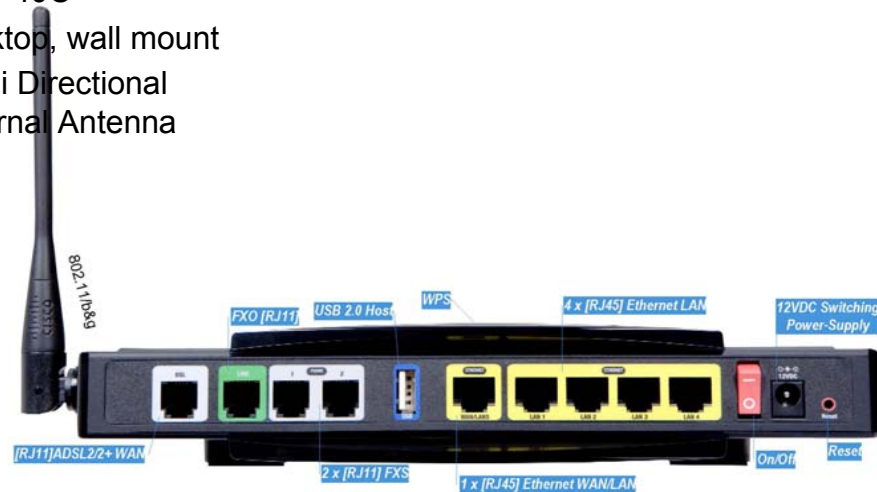

Linksys is building DSL platforms to meet ISP's requirements

Internet Video Camera Market Segments

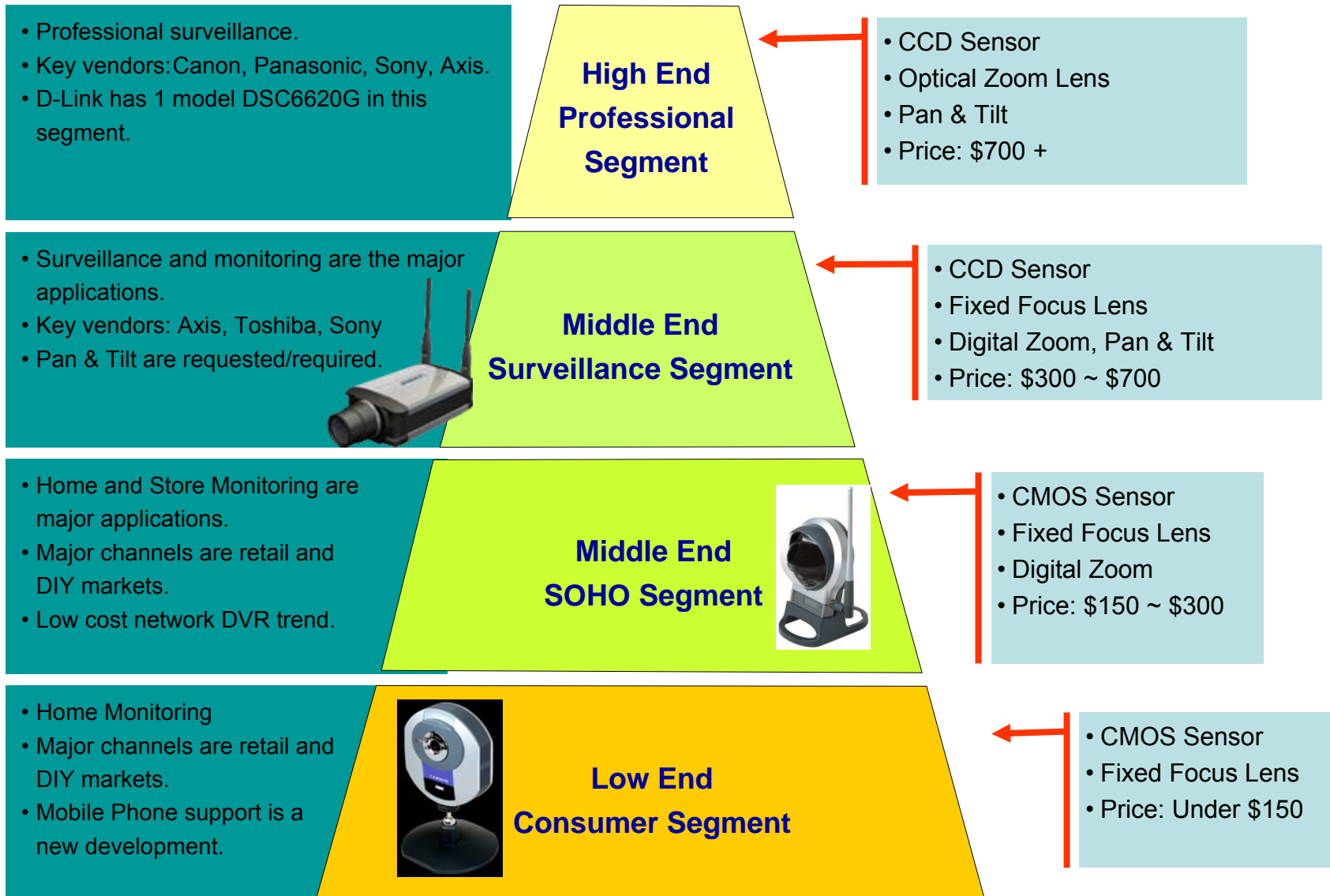

Z-wave: home control and monitoring technology

- Cisco is investor in Zensys, and influenced TCP/IP as transport
- Zensys has developed Z-Wave™, a low-cost RF-based control and monitoring technology
- Z-Wave enables embedded intelligence and wireless communication for applications such as
 - lighting and appliance control
 - meter reading
 - thermostat and ventilation control
 - Security
 - residential gateway connectivity
- Z-Wave transforms stand-alone device into an intelligent networked device that can be controlled and monitored wirelessly

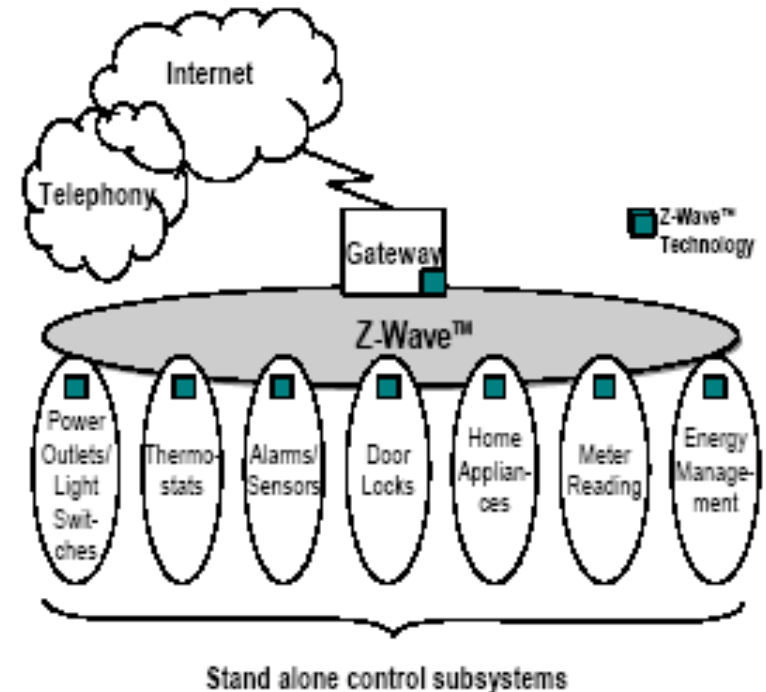

Zen-sys home automation



Z-Wave World of Home Control Solutions



Average # of Nodes per Home

	Homes	Appts
Simple Home Control		
1 / 2 / 3-way switches	~ 10	~ 5
Light / lamp dimmers	~ 12	~ 5
Universal remote control	~ 3	~ 1
Appliances	~10	~ 5
Smoke sensors	~8	~ 3
Remote Home Monitoring		
Door / window sensors	~ 15	~ 5
Door locks	~ 3	~ 1
PIR / IP cameras	~ 5	~ 2
Gateway & Management SW	~ 1	~ 1
Energy Conservation		
Thermostats	~ 3	~ 1
Smart appliances	~10	~ 4
Entertainment Control		
Media Center PC	~2	~ 1
TV / STB / DMA / PVRs	~8	~ 3
Drape control	~8	~ 4
Home Health Care		
Smart gateway / USB	~2	~ 1
Pressure sensors	~8	~ 4
Medical sensors	~12	~ 6
Gas / Co2 sensors	~5	~ 3
Other		
Ceiling fans		
Garage door openers		
Door locks		

➔ **Total Number of Nodes ~ 125 ~ 55**

Energy Conservation

Entertainment Control

Home HealthCare

Remote Home Monitoring

On the Road

@ Work



Internet Media Server

- **New class of Media Server – Store and access all of your Music, Photo and Home movies with or without a PC**
- **Free space UI and remote that makes discovering your content a fun experience**
- **Easily create your Music Playlists and Custom channels**
- **Wireless connection to all your content stored on your PC and networked devices**



- Major Functionality (C-series)
 - CD/DVD Player
 - AV Server
 - Audio/Video/Photo DMA
 - Online Info and Content
 - HC ZUI with Ring Remote
- Video Outputs
 - Component, HDMI
 - Video Scaling (1080p)
- Audio Outputs
 - Stereo Analog, SPDIF Coax, Toslink
- Miscellaneous
 - 200+GB HDD
 - 2 IR outputs for SI control
 - Audio Encode (MP3, WMA, AAC, FLAC)
- Connectivity
 - USB2.0
 - 10/100 Ethernet and 802.11n (DB) with EGHN
- Interoperability
 - UPnP and DLNA 1.5

Media Server Sample UI



Internet Audio Center

- **Bring your digital music experience to new locations in the home such as your kitchen**
- **Enjoy premium music and Internet Radio services w/ or w/o PC**
- **Easily find your music on a Hi-res. LCD Touch-screen with a rich graphical User Interface**



- Major Functionality (C-series)
 - CD Player (optional)
 - AM/FM Tuner (optional)
 - Audio/Photo DMA
 - Online Info and Streaming Content
 - HC ZUI with Touch screen
- A/V
 - 2.1 Internal speakers and amps
 - 2 Analog audio inputs
 - Headphone output
- Connectivity
 - USB2.0
 - 10/100 Ethernet
 - 802.11n (dual band) with EGHN
- Interoperability
 - UPnP and DLNA 1.5

Audio Center Sample UI



Other “Connected Home” Media devices



Internet Audio Center

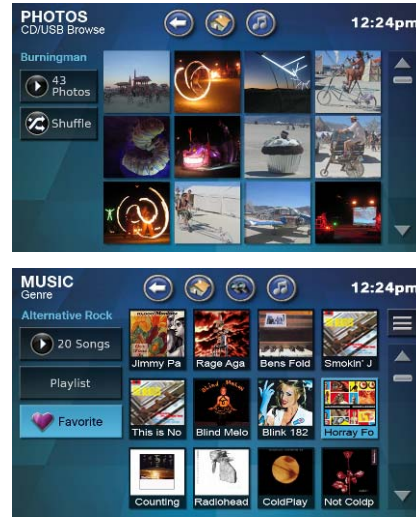

Internet Media Server



Digital Picture Frame



Home
Phone
System