

VSR-2 Chassis Administrator's Guide

Compatible Systems Corporation
4730 Walnut Street
Suite 102
Boulder, Colorado 80301

303-444-9532
800-356-0283
<http://www.compatible.com>

VSR-2 Chassis Administrator's Guide, Version 1.0
Copyright© 1999, Compatible Systems Corporation

All rights reserved. VSR, VSR-2, MicroRouter and CompatiView are trademarks of Compatible Systems Corporation. Other trademarks are the property of their respective holders.

Part number: A00-1615

FCC Notice: This product has been certified to comply with the limits for a Class A computing device, pursuant to Subpart J of Part 15 of FCC Rules. It is designed to provide reasonable protection against radio or television communication interference in a commercial environment. Operation of this equipment in a residential area could cause interference with radio or television communication.

Table of Contents

Introduction to the VSR-2	1
VSR-2 INSTALLATION OVERVIEW	1
VSR-2 MANUAL OVERVIEW	1
Chapter 1 - Getting Started	2
A FEW NOTES	2
Please Read the Manuals	2
Warranty and Service	2
Getting Help with the VSR-2	2
WHAT YOU WILL NEED TO GET STARTED	3
Supplied with the VSR-2	3
Additional Items Needed for Installation	4
Chapter 2 - Mounting Instructions	5
CHANGING THE POWER SUPPLY VOLTAGE SETTINGS	5
RACK MOUNTING INSTRUCTIONS	6
Standard 19-inch Rack Mount	6
Earthquake Mount in a 19-inch Rack	7
Telco Rack Mount	10
Wall Mount	11
POWER CORD RETAINER INSTALLATION	13
Chapter 3 - CompatiView Software Installation	14
COMPATIVIEW FOR WINDOWS	14
System Requirements	14
Installation and Operation	14
Transport Protocols and CompatiView	15
Chapter 4 - Command Line Management	16
OUT-OF-BAND COMMAND LINE MANAGEMENT	16
TEMPORARILY RECONFIGURING A HOST FOR COMMAND LINE MANAGEMENT	16
SETTING UP TELNET OPERATION	17
Appendix A - Test Switch Settings	18
Appendix B - Connector and Cable Pin Outs	19
PIN OUTS FOR DB-25 MALE TO DB-25 FEMALE CONSOLE CABLE	19
Appendix C - Downloading Software From Compatible Systems	20
Appendix D - When the “Over Temp” Light Comes On	21
REPLACING OR CLEANING THE VSR-2 AIR FILTER	22
Appendix E - Terms and Conditions	23

List of Figures

Figure 1. Mounting Screws	4
Figure 2. Location of Voltage Switch on the Power Supply	5
Figure 3. Standard Rack-Mount Bracket Installation	6
Figure 3.1 Mounting the VSR-2 in the Rack	6
Figure 4. Installing Bracket Extenders	7
Figure 4.1. Installing Earthquake Rack-Mount Brackets	8
Figure 4.2 Mounting the VSR-2 Chassis in the Rack	9
Figure 5. Installing Telco Rack-Mount Brackets	10
Figure 5.1. Mounting the VSR-2 Chassis in the Telco Rack	10
Figure 6. Installing Wall-Mount Brackets	11
Figure 6.1. Securing the VSR-2 Chassis to the Board	12
Figure 7. Attaching the IntraPort Enterprise-2 Power Cord Retainer	13
Figure 8. Removing the Chassis Cover and Filter	22

Introduction to the VSR-2

Congratulations on your purchase of the VSR-2 multigigabit switching router. The VSR family of products supports the IP, IPX, AppleTalk and DECnet network protocols, with OSPF and BGP protocol support for backbone routing operations. The VSR-2 system consists of a chassis and one or two Routing Input/Output Processors (RIOPs).

VSR-2 Installation Overview

This manual will help you mount the VSR-2 Chassis in a rack and install it on your network. It also includes general maintenance information and some technical specifications. For the most up-to-date information available on the VSR-2, please visit the Technical Support section of our Web site at: <http://www.compatible.com>.

In short, the installation steps are:

1. **Mount** the VSR-2 Chassis in a rack or other appropriate setting.
2. **Install** the IntraPort Enterprise-8 hardware on your network and connect the 10/100 twisted-pair Ethernet interfaces to Fast Ethernet or Ethernet hubs.
3. **Select** the management tool you wish to use with the server. If you want to use the ComatiView management software, you must install the software on a Windows PC computer which is connected to your network.
4. **Configure** the VSR-2 parameters using the management tool you have chosen.

VSR-2 Manual Overview

This section of the manual contains general information about installing and managing the VSR-2.

In addition to this general information, each Routing Input/Output Processor (RIOP) card available in the VSR family has been documented separately.

The VSR-2 Chassis section of the manual is divided into the following sections:

Chapter 1: Getting Started

This part of the manual describes the contents of the VSR-2 package and emphasizes the preparation and equipment you will need to install the router.

Chapter 2: Mounting Instructions

This part of the manual includes detailed instructions for mounting the VSR-2 in a variety of equipment racks.

Chapter 3: ComatiView Software Installation

If you plan to use ComatiView, Compatible Systems' GUI (Graphical User Interface) management software which is included with your router, then read this section. Instructions are provided on how to install ComatiView for Windows environments.

Chapter 4: Command Line Preparation

If you have decided to use command line management and text-based configuration, either out-of-band (through the router's Console interface) or in-band through Telnet, read this section.

Appendices

Additional information that might be of interest to you, such as test switch settings, technical specifications and how to download current software, can be found at the end of this guide.

Chapter 1 - Getting Started

A Few Notes

Please Read the Manuals

The manuals included with your VSR-2 contain very important information about installing and operating the IntraPort Enterprise-8. Please read this manual, and refer to the management reference guides as required. It's worth the few minutes it will take.

Also, please fill out the warranty registration card and return it to us today. This will help us keep you informed about updates to the VSR-2 and future products available from Compatible Systems.

You can also register on the Web at <http://www.compatible.com>. If you'd like to be notified via e-mail about new products and receive important news from Compatible Systems, please join our e-mail list on the Web.

Warranty and Service

The VSR-2 is covered by the Compatible Systems Integrated Support Package, which includes a lifetime comprehensive warranty, a twenty-four hour advanced replacement program, unlimited phone support and software upgrades for the life of the product. A 24 x 7 support plan is also available.

Compatible Systems maintains copies of current software updates on the Internet. You may download product software from the Internet at any time. For more information on downloading current product software, see Appendix C.

Getting Help with the VSR-2

If you have a question about the VSR-2 and can't find the answer in one of the manuals included with the product, please visit the technical support section of our Web site (<http://www.compatible.com>). This site includes extensive technical resources which may answer many of your questions. You can also request technical support by filling out a brief form. Technical support requests received via the Web form will receive expedited treatment. You may also call Compatible Systems Corporation or send support questions via e-mail to support@compatible.com. Compatible Systems' phone number is listed on the front of this guide. We will be happy to help you.

What You Will Need to Get Started

Before connecting the VSR-2, please check the list below to make sure that you have received all of the items that are supplied with the VSR-2 package.

Supplied with the VSR-2

- VSR-2 unit
- Power cord
- One left earthquake rack-mount bracket
- One right earthquake rack-mount bracket
- One left long rack-mount extender
- One right long rack-mount extender
- Two short rack-mount extenders
- Two Telco/wall-mount brackets
- Two handle spacers
- Two handles
- 32 assorted mounting screws (see Figure 1)
- One DB-25 male to DB-25 female console cable
- Two DB-26 male to Quad RJ-45 cables (Octal T1 RIOP only)
- Two Quad V.35 to High Density D-Sub (HD D-Sub) female interface cables (Octal V.35 RIOP only)
- Eight HD D-Sub male to V.35 male adapter cables (Octal V.35 RIOP only)
- One reusable replacement air filter
- One power cord retainer
- One cable tie
- CD-ROM including:
 - CompaView software for Windows
 - Operating software
 - HTML versions of product documentation (which can be viewed with your favorite web browser)
- *CompaView Management Software Reference Guide*
- *Text-Based Configuration and Command Line Management Reference Guide*
- Warranty registration card

The following illustration shows the type and quantity of each screw.

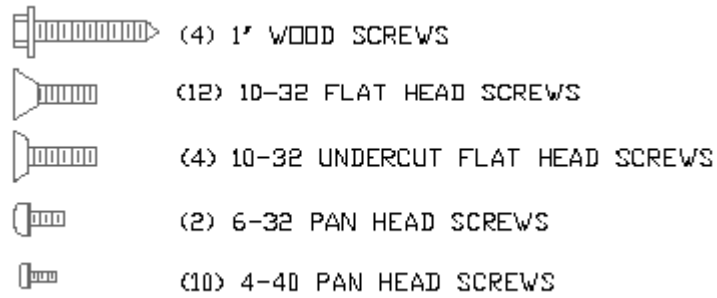

Figure 1. Mounting Screws

Additional Items Needed for Installation

Before connecting the VSR-2 to your network, you need to make sure that you have the necessary equipment. See each RIOP card's Network Installation section for details.

Chapter 2 - Mounting Instructions

The VSR-2 multigigabit switching router can be left stand-alone on a desktop or equipment table or it can be mounted in a 19-inch rack, a telco rack or on a wall. Compatible Systems provides all the parts necessary for securing the supplied mounting brackets to the device; however, due to the variety of equipment racks and mounting techniques, you will need to provide your own screws or clips to secure the mounting brackets to the equipment rack or wall.

❖ **Note:** *When stacking other equipment on the VSR-2 multigigabit switching router, do not exceed 35 pounds of evenly distributed weight on top of the router. Additional weight may bend the case.*

Changing the Power Supply Voltage Settings

The default setting for the voltage switch on the power supply for the VSR-2 is for a low input voltage (marked 115V on the switch). If your electrical system requires a high input voltage on the power supply, you must change it manually on the device before plugging the device in.

To change the settings:

1. Make sure the router is powered down and not connected to any power source.
2. Remove the front bezel by prying carefully using a flat head screwdriver to loosen it.
3. Using a small screw driver, change the voltage switch to the desired setting (230V for high input voltage, 115V for low input voltage).
4. Replace the front bezel by firmly pressing it into the 6 slots.

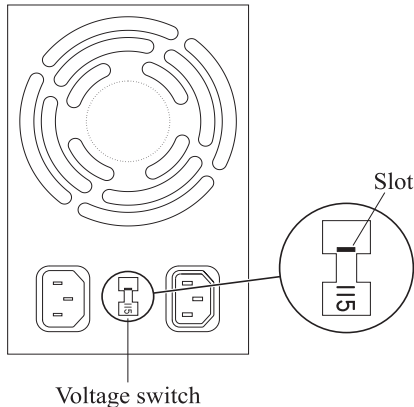

Figure 2. Location of Voltage Switch on the Power Supply

Rack Mounting Instructions

Standard 19-inch Rack Mount

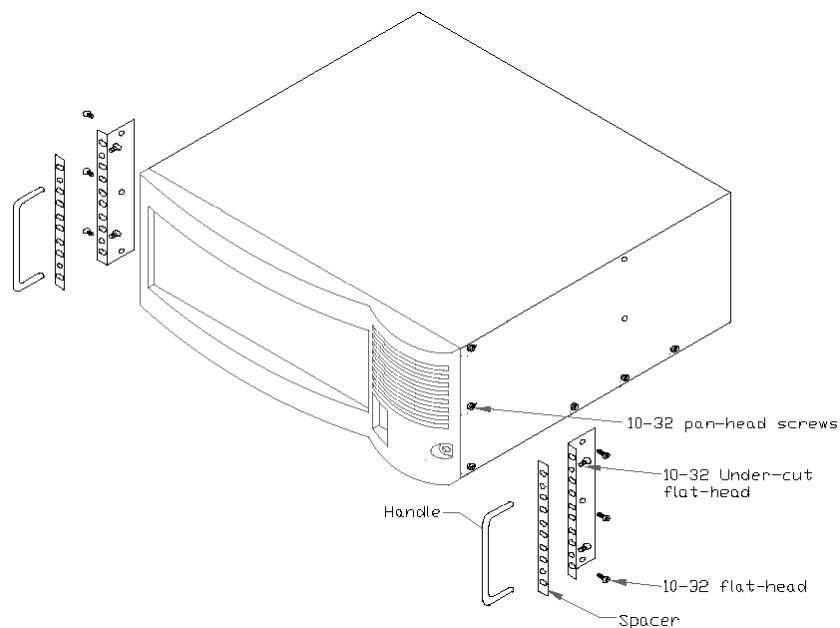

Figure 3. Standard Rack-Mount Bracket Installation

Brackets are provided for mounting the VSR-2 in a standard 19-inch equipment rack. To rack-mount the router in a standard equipment rack:

1. Determine the desired location. The VSR-2 requires 6.5 vertical inches (4 shelf positions) of rack space.
2. Remove the front three vertically aligned pan-head machine screws from each side of the VSR-2 chassis as illustrated in Figure 3.
3. Using the black 10-32 flat-head screws provided, install the mounting brackets on the sides of the router as shown.
4. Using the undercut 10-32 flat-head screws provided, install the handle and spacer on the front of the mounting brackets as shown. (This step is optional.)

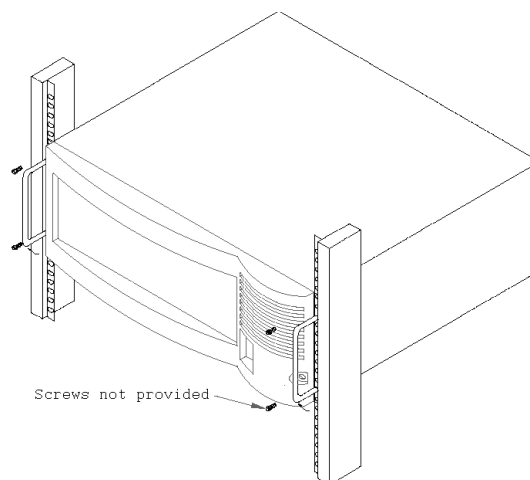

Figure 3.1 Mounting the VSR-2 in the Rack

5. Using your screws or clips, fasten the mounting brackets to the equipment rack as shown in Figure 3.1.

Earthquake Mount in a 19-inch Rack

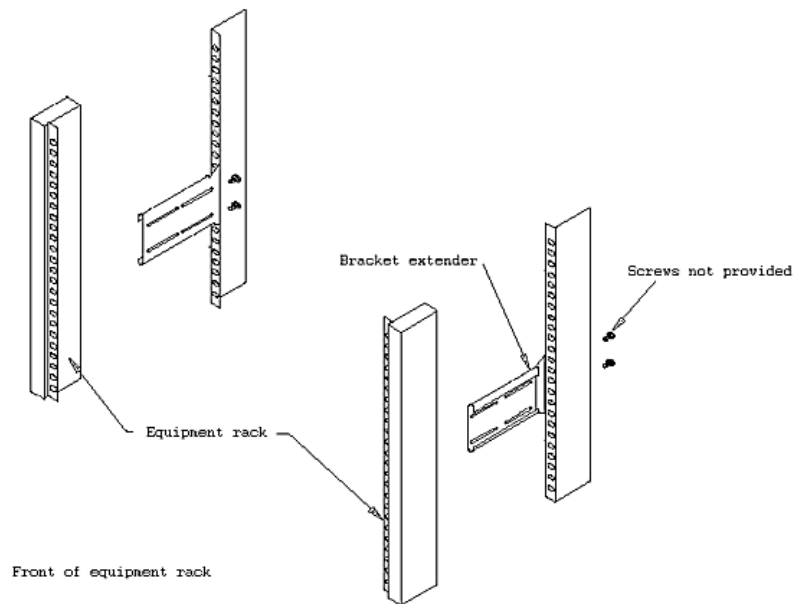

Figure 4. Installing Bracket Extenders

Earthquake brackets are provided for mounting the VSR-2 in a standard 19-inch equipment rack. If the router will be located in an area prone to earthquakes, it is strongly recommended that you use the earthquake brackets for mounting the device. To earthquake-mount the router in a standard equipment rack:

1. Determine the desired location. For proper placement of the brackets and extenders, it is recommended that you first assemble the unattached brackets and extenders in the equipment rack, using your own bracket-mounting screws or clips. Then remove the front two brackets as illustrated in Figure 4 (be sure to mark their places on the equipment rack). The VSR-2 requires 6.5 vertical inches (4 shelf positions.)

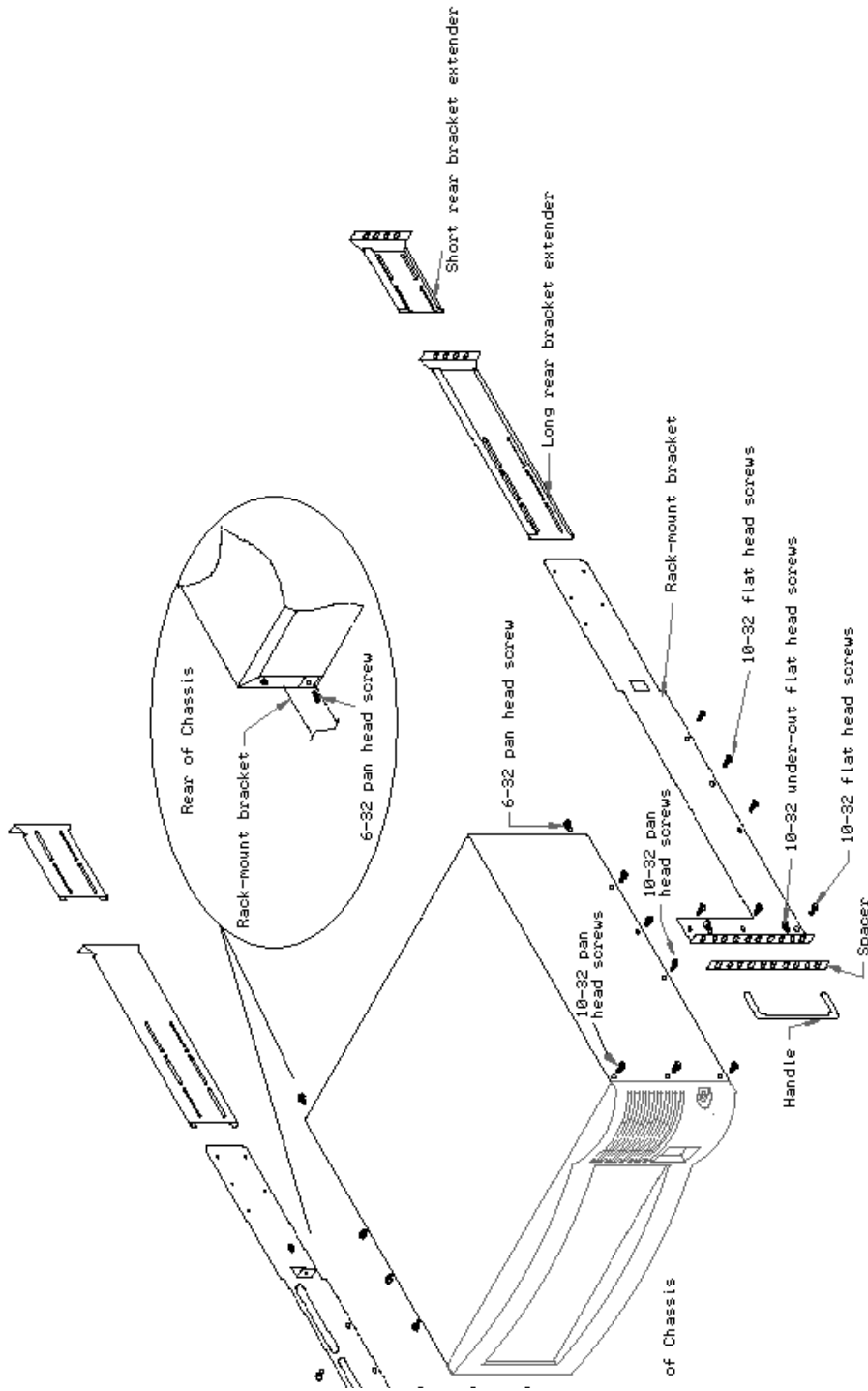

Figure 4.1. Installing Earthquake Rack-Mount Brackets

2. Remove the 6 pan-head machine screws from each side of the VSR-2 chassis and the two bottom corner pan-head machine screws from the rear of the chassis as illustrated in Figure 4.1. Be sure to set the screws in a safe place so that you may use them later if you change the mounting.
3. Using the black 10-32 flat-head screws provided, install the mounting brackets on the sides of the router as shown in Figure 4.1. Using the provided 6-32 pan-head screws, fasten the rear of the chassis to the rear tab of the mounting bracket.
4. Using the undercut 10-32 flat-head screws provided, install the handles and spacers on the front of the mounting brackets as shown in Figure 4.1.

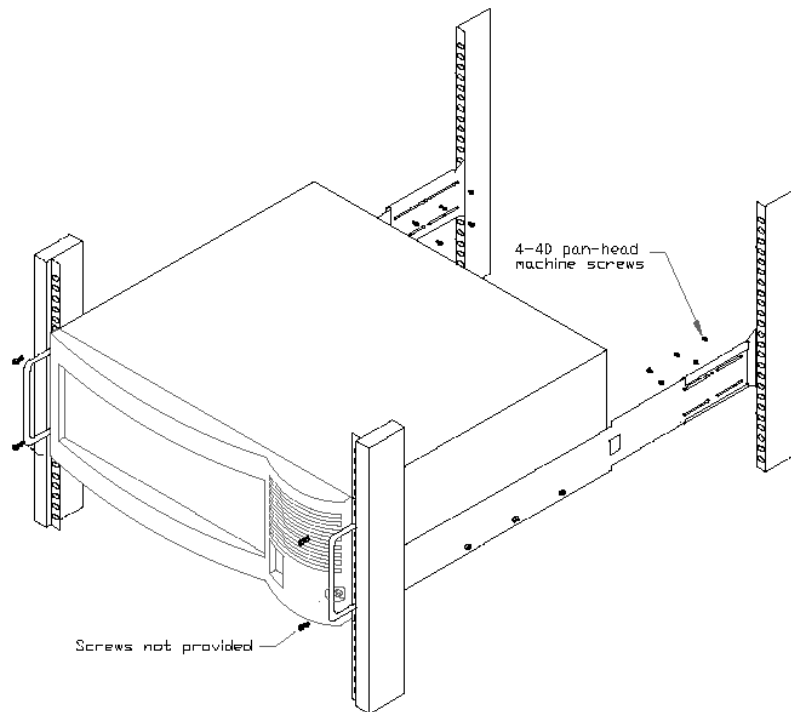

Figure 4.2 Mounting the VSR-2 Chassis in the Rack

5. While supporting the VSR-2 chassis, slide the rack-mount brackets into the installed rear extenders as shown in Figure 4.2.
6. Using your screws or clips, fasten the front bracket to the equipment rack as shown in Figure 4.2.
7. Using the provided 4-40 pan-head screws, fasten the brackets and bracket extenders together. The standard rack-mount bracket, extender and screws fit together as shown in Figure 4.2.

Telco Rack Mount

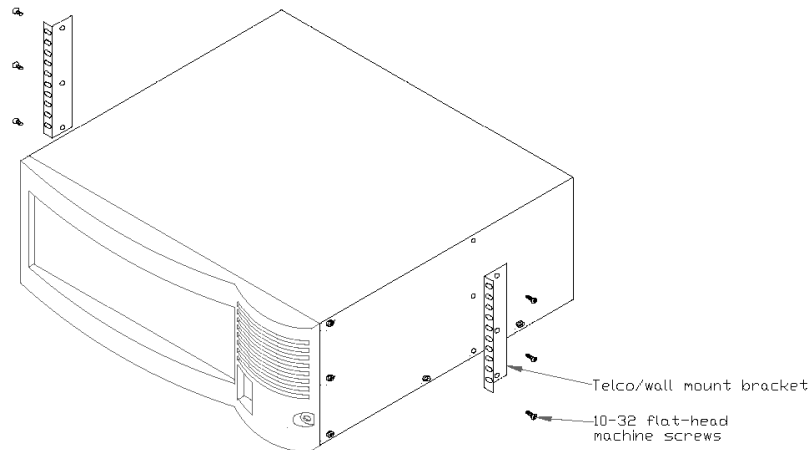

Figure 5. Installing Telco Rack-Mount Brackets

Brackets are provided for mounting the VSR-2 chassis in a telco rack. To rack-mount the VSR-2 into a telco rack:

1. Determine the desired location. The VSR-2 chassis requires 6.5 vertical inches (4 shelf positions) of rack space.
2. Remove the bottom center pan-head machine screw from each side of the VSR-2 chassis.
3. Using the black 10-32 flat-head screws provided, install the Telco/wall-mount brackets on the sides of the router as shown in Figure 5.

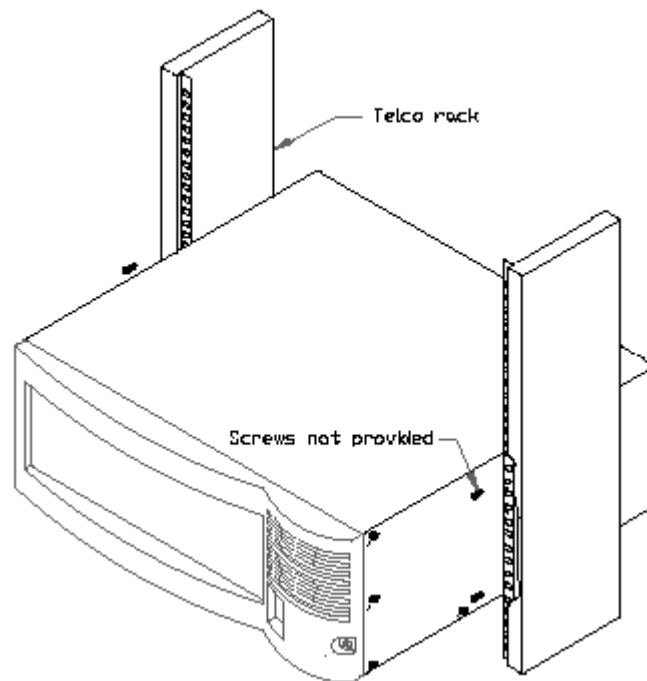

Figure 5.1. Mounting the VSR-2 Chassis in the Telco Rack

4. While supporting the VSR-2 chassis, move the device and the mounting brackets into the desired rack position and use your own screws or clips to fasten the VSR-2 and bracket to the rack as shown in Figure 5.1.

Wall Mount

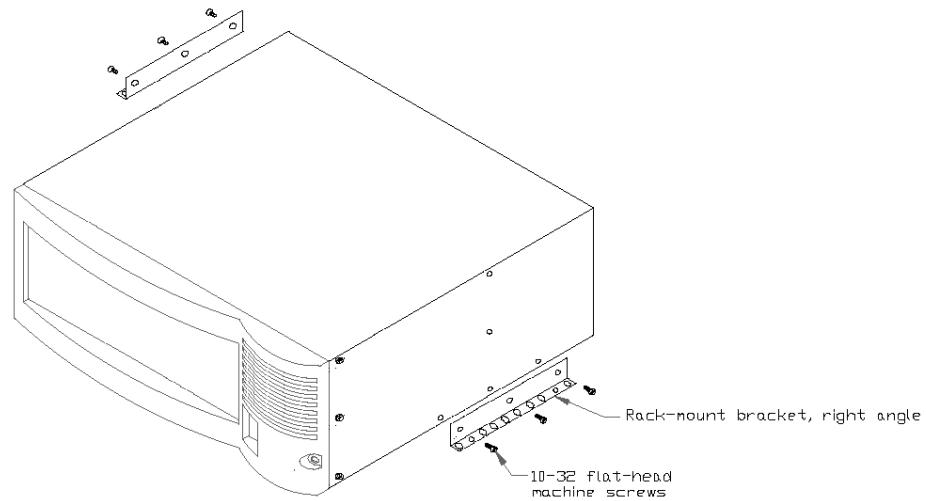

Figure 6. Installing Wall-Mount Brackets

Brackets are provided for mounting the VSR-2 on a wall. To wall-mount the VSR-2:

1. Determine the desired location. The VSR-2 chassis requires a mounting backboard measuring at least 24" x 24" x 1/2" (not supplied).
2. Remove the three bottom 10-32 pan-head machine screws from each side of the VSR-2 chassis as illustrated in Figure 6.
3. Using the 10-32 black flat-head screws provided, install the telco/wall-mount brackets on the sides of the router as shown.

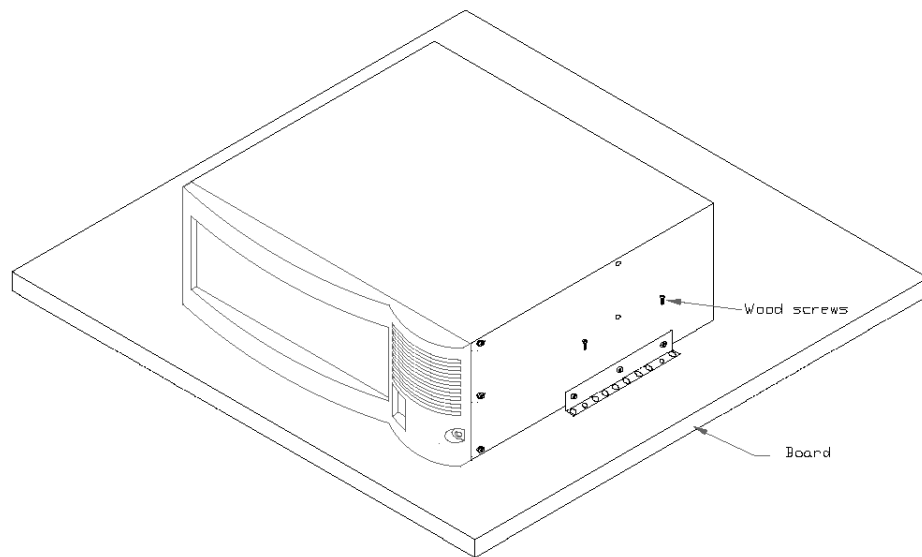

Figure 6.1. Securing the VSR-2 Chassis to the Board

4. Lay the VSR-2 on top of the board and mark the wall-mount screw locations on the board. To make inserting the screw easier, pre-drill the screw locations before you mount the device.

❖ **Note:** *If the backboard on which the VSR-2 chassis will be mounted is already installed, skip to Step 6.*

5. Locate the wall studs and, using your own screws, attach the mounting backboard securely to the wall by screwing the board to the studs.

❖ **Note:** *The VSR-2 should be wall-mounted with the front and rear of the chassis perpendicular to the floor and at eye level, so you can read the front LEDs. All four mounting screws must be anchored to solid wood.*

6. Using the supplied wood screws, fasten the VSR-2 to the board as illustrated in Figure 6.1, starting with the top bracket and then the bottom. **Use extreme caution during this step**, making sure you are securely supporting the weight of the device until it is firmly fastened to the board.

Power Cord Retainer Installation

INSTRUCTIONS FOR ATTACHING THE VSR-2 POWER CORD RETAINER

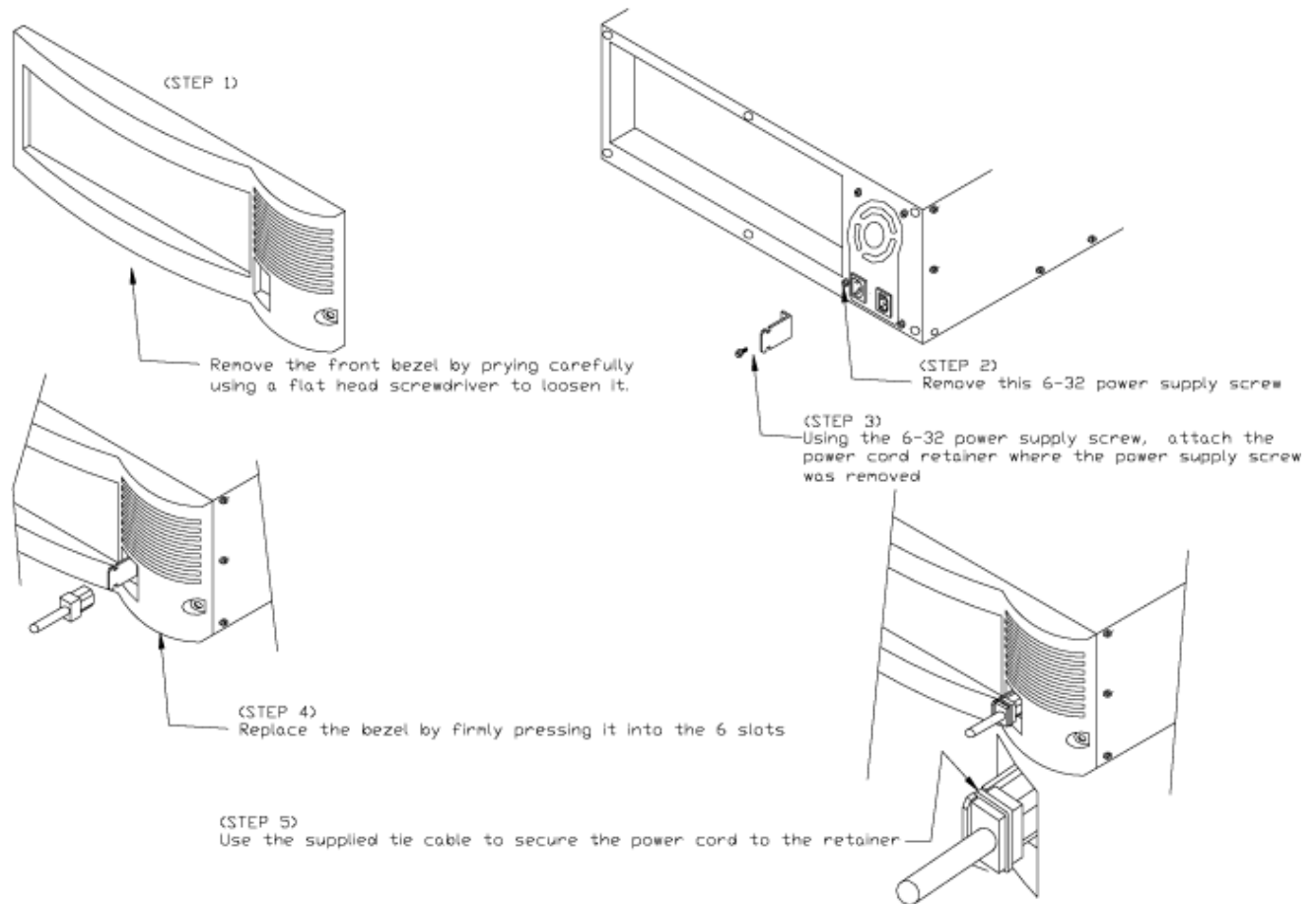

Figure 7. Attaching the IntraPort Enterprise-2 Power Cord Retainer

❖ **Note:** It is recommended that you determine the setting of your voltage switch before installing the power cord retainer. For more information on power supply voltage settings, see [Changing the Power Supply Voltage Settings at the beginning of this chapter.](#)

Chapter 3 - CompatiView Software Installation

All of the products in Compatible Systems' internetworking and VPN families, including the VSR-2, can be managed from a single GUI management platform called CompatiView. CompatiView for Windows is included on the CD-ROM which was shipped with your VSR-2.

❖ **Note:** *An older version of CompatiView for Mac OS was included on the CD-ROM shipped with your router. The Mac OS version can be used with other Compatible products such as MicroRouters and RISC Routers; however, it is not compatible with the VSR-2 software. You must use CompatiView for Windows, versions 5.0 or later, to manage your router with CompatiView.*

CompatiView for Windows

CompatiView for Windows allows you to manage the router from an IBM-compatible PC running Windows 95/98 or Windows NT. The PC can either be configured as an IPX client on a Novell NetWare internet, or as an IP WinSock client on an IP internet.

System Requirements

In order to successfully run CompatiView for Windows, you need:

- IBM PC or compatible w/ 486 or later processor
- Microsoft Windows 95/98 or Windows NT installed
- VGA or better monitor
- IP - A WinSock-compatible transport stack
and/or
- IPX - A Netware or Microsoft Client installation

❖ **Note:** *To choose the active transport protocol on a Windows machine which has both IPX and IP installed, select "Options" from the Database menu and click the General tab. Then select the appropriate radio button under "Transport."*

Installation and Operation

The Windows version of the CompatiView program can be found in the Network Management/CompatiView/Windows directory on the CD-ROM that was included with your VSR-2.

Run the auto-installation program (CV5x file) by double-clicking on it. The installation program will ask you to select (or create) a directory in which it should locate CompatiView and its associated files and database subdirectory.

Once the installation is complete, double click on the CompatiView icon to open the program. For further information on using CompatiView, see the *CompatiView Management Software Reference Guide* included with your router.

❖ **Note:** *For an up-to-date description of the changes (if any) made to Windows system files by the installation program, see the README.TXT file located in the CompatiView installation directory.*

Transport Protocols and CompatiView

CompatiView will be able to use the transport protocol (IP or IPX) you have selected to access Compatible Systems products anywhere on your internetwork. Depending on your security setup, you may also be able to use the IP transport option to manage devices across the Internet.

The IP protocol does not provide a method for CompatiView to automatically discover the router. To initially contact the router over IP using CompatiView, you must first enter a valid IP address into the router. You can do this either on a console directly connected to the router or by setting a workstation's IP address to 198.41.12.2 with a Class C subnet mask (255.255.255.0) so that it can communicate over Ethernet with 198.41.12.1 (the shipping default of Ethernet 0:0). After setting the router's IP address, be sure to change the workstation's configuration back to its original settings.

The IPX protocol does allow CompatiView to automatically discover the router. Compatible Systems devices are configured to autoseed the two most common IPX frame types upon startup (802.2 and 802.3 (raw)). If CompatiView has the IPX/SPX protocol selected as its transport, it will be necessary to either powerup the router before powering up the workstation, or reboot the workstation after the router has completed its boot sequence. This process will ensure that the workstation and the router have the proper IPX network bindings for communication.

Chapter 4 - Command Line Management

The command line interface allows you to configure and monitor the router in-band via Telnet or out-of-band with a terminal connected to the router's Console interface.

❖ **Note:** *Proper syntax is vital to effective operation of command line management. Case is not significant – you may enter commands in upper case, lower case, or a combination of the two.*

Out-of-Band Command Line Management

You can use command line management and text-based configuration out-of-band as a permanent management tool, or only temporarily in order to set the router's IP parameters to allow in-band Telnet access.

In order to access the command line out-of-band, do the following:

1. Set a terminal or a PC equipped with VT100 terminal emulation to a baud rate of 9600, 8 bits, no parity, 1 stop bit and no Flow Control.
2. Connect it to the router's Console interface using the cable which was supplied with the VSR-2.
3. Press the <Return> key one or two times.
4. Enter the default password *letmein* at the password prompt. The command line interface prompt will appear on the screen.

If you plan to use out-of-band access for ongoing management of your router, you can find further information on configuring your router in each RIOP card's Basic Configuration section for details. Otherwise, see the section later in this chapter on Setting Up Telnet Operation for information on setting the router to allow Telnet access from hosts on its network.

Temporarily Reconfiguring a Host for Command Line Management

You can temporarily reconfigure an IP host in order to set the router's IP parameters to allow in-band Telnet access.

If you wish to set the router's basic IP parameters in this fashion, the host must be on the same Ethernet segment as one of the router's Ethernet interfaces. You can then do the following:

1. Set the host's IP address to 198.41.12.2, with a Class C subnet mask (255.255.255.0) and then Telnet to 198.41.12.1.
2. Enter the default password *letmein* at the password prompt. The command line interface prompt will appear on the screen.
3. Use the **configure** command and set the **IPAddress**, **SubnetMask**, and **IPBroadcast** keywords in the **IP Ethernet 0** section.
4. Use the **save** command to save the changes to the device's Flash ROM.
5. Change the host's configuration back to its original settings

See the next section (Setting Up Telnet Operation) for information on setting the router to allow Telnet access from hosts on its network.

Setting Up Telnet Operation

Telnet is a remote terminal communications protocol based on TCP/IP. With Telnet you can log into and manage the VSR-2 from anywhere on your IP internetwork, including across the Internet if your security setup allows it. To manage the router with Telnet, you must

1. Run Telnet client software on your local computer, which will communicate with the Telnet server built into the VSR-2.
 2. You must also set some basic IP parameters in the router. The required parameters for Telnet access to an interface are the IP address, IP subnet mask, and IP broadcast address. There are several ways to set them.
- You may set them using text-based configuration either out-of-band via the Console interface or in-band via a reconfigured IP host. Instructions for setting up these two methods were given earlier in this chapter. Once you have set up the command line interface, do the following:
 - A. Use the **configure** command and set the **IPAddress**, **SubnetMask**, and **IPBroadcast** keywords in the **IP Ethernet 0:0** section.
 - B. Use the **save** command to save the changes to the device's Flash ROM.
 - You may also use CompatiView from a reconfigured IP host (if using the IP transport protocol), or anywhere on your network (if using the IPX transport protocol). Instructions for these two methods are given in Chapter 4 - CompatiView Software Installation.

With CompatiView, basic IP parameters can be set using the TCP/IP Routing: Ethernet 0:0 Dialog Box. Use the Save to/Device option under the File menu to save the changes.

After you have set these IP parameters and saved the changes, you can use Telnet to access the router from any node on your IP network. Invoke the Telnet client on your local host with the IP address of the router you wish to manage.

Appendix A - Test Switch Settings

- 0 Normal Operation
- 1 Unused*
- 2 Unused*
- 3 Run Boot ROM Downloader
- 4 Unused*
- 5 Erase Flash ROM (OS and Configuration)
- 6 Erase Flash ROM (Configuration Only)
- 7 Unused*
- 8 Unused*
- 9 Allow *letmein* password for 5 minutes after powerup

⚠ **Caution:** Settings marked with an asterisk may erase your Flash ROM. Please do not use these settings without first contacting Compatible Systems Technical Support.

Appendix B - Connector and Cable Pin Outs

Pin Outs for DB-25 Male to DB-25 Female Console Cable

The cable supplied with the VSR-2 is twenty-five conductors, straight through. Connections on the console interface follow the standard RS-232 pin outs.

Appendix C - Downloading Software From Compatible Systems

The latest versions of operating software for all Compatible Systems products are available at our Web site. The latest version of CompaView management software is also available.

To download software, follow the instructions below.

1. Use your browser to access <http://www.compatible.com/>, and find the link on our home page to “Software Downloads.”
2. Select the product and software version you want, and click on the appropriate file to download it.

❖ **Note:** *These files are also accessible directly via Anonymous FTP at <ftp.compatible.com/files/>.*

Appendix D - When the "Over Temp" Light Comes On

The VSR-2 is designed to operate reliably in a normal computer room, and requires no special environmental control. If operating within its published temperature and humidity specifications in a normal computer room, no periodic maintenance is required. If, however, the "Over Temp" light illuminates, it indicates that the internal circuitry is operating above its specified temperature range. If this happens, perform the following check sequence:

1. Verify that the router is installed properly in an environment in which the air temperature around the router is within the specified limits.
2. Verify that air flow to the front and left side of the router (as viewed from the front of the unit) is unrestricted.
3. If the above checks do not indicate a problem, it is probable that the air filter inside the chassis is clogged and must be cleaned or replaced. Follow the procedure outlined next to clean and replace the dust filter.

Replacing or Cleaning the VSR-2 Air Filter

Under normal operation, the air filter does not require periodic maintenance. The filter should be replaced only when an excessive amount of dirt and dust has collected over an extended period of time. A replacement filter is supplied with the unit to minimize the unit's down time when the filter is replaced.

Before attempting to change or clean the filter, the unit must be removed from its mounting in an equipment rack or on a wall. Changing or cleaning the filter is a simple process.

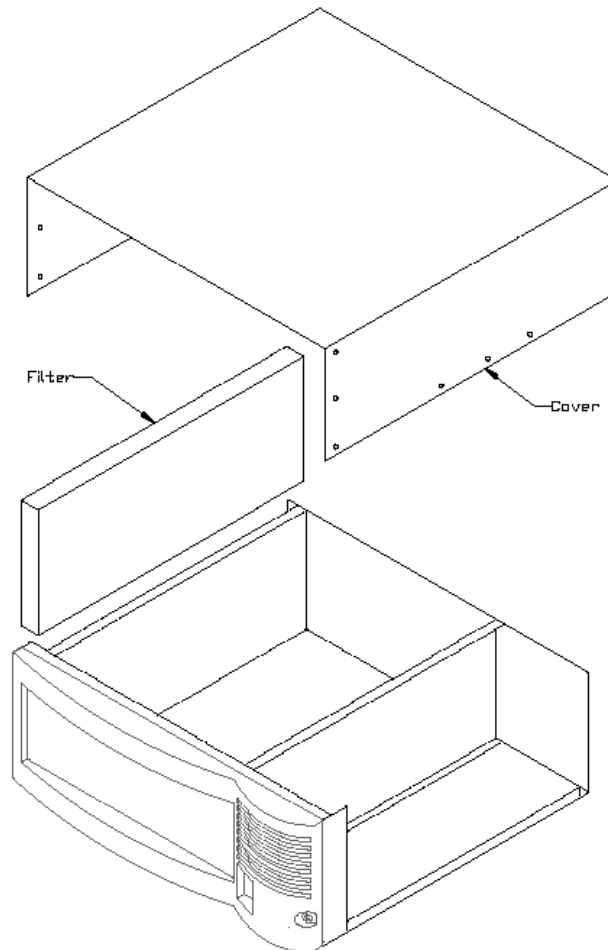

Figure 8. Removing the Chassis Cover and Filter

1. Remove the front three vertically aligned screws and the middle three horizontally aligned screws from each side of the chassis, as illustrated in Figure 8.
2. Remove the top panel from the chassis.
3. Remove the filter from its slot.
4. Put the supplied replacement filter in the slot. The used filter may be washed in warm, soapy water and used again once it is completely dry.
5. Replace the top panel.
6. Fasten the top to the chassis with the screws you removed in Step 1.
7. If the chassis was removed from an equipment rack, return it to its mounting, following the instructions as outlined in Chapter 2 - Mounting Instructions.

❖ **Note:** *If either of the supplied filters is worn out or cannot be thoroughly cleaned, you may order a replacement filter from Compatible Systems Corporation at the number in the front of*

this manual.

Appendix E - Terms and Conditions

Compatible Systems Corporation (Compatible Systems) offers to sell only on the condition that Customer's acceptance is expressly limited to Compatible Systems' terms and conditions of sale. Compatible Systems' acceptance of any order from Customer is expressly made conditional on assent to these terms and conditions of sale unless otherwise specifically agreed to in writing by Compatible Systems. In the absence of such an agreement, commencement of performance or delivery shall be for Customer's convenience only and shall not be construed as an acceptance of Compatible Systems' terms and conditions. If a contract is not earlier formed by mutual agreement in writing, Customer's acceptance of any goods or services shall be deemed acceptance of the terms and conditions stated herein.

1. **Warranty.** Compatible Systems warrants to the Customer and to all persons who purchase Products from the Customer during the Warranty terms ("subsequent purchasers"), that, for an unlimited period from the date (the "shipping date") on which Compatible Systems ships the Products to the Customer: (a) the Product meets, in all material respects, all specifications published by Compatible Systems for such Products as of the shipping date; (b) the Products are free from all material defects in materials and workmanship under normal use and service; and (c) that as a result of the purchase of the Products from Compatible Systems, the Customer will have good title to the Products, free and clear of all liens and encumbrances.

Compatible Systems' obligations pursuant to this Warranty, and the sole remedies of the Customer and of any subsequent purchaser, shall be limited to the repair or replacement, in Compatible Systems' sole discretion, of any of the Products that do not conform to this Warranty.

This Warranty shall be invalidated if the Products (a) have not been installed, handled, or used in accordance with Compatible Systems recommended procedures; (b) have been damaged through the negligence or abuse of the Customer or of any subsequent purchasers; (c) are damaged by causes external to the Products, including (without limitation) shipping damage, power or air conditioning failure, or accident or catastrophe of any nature; and (d) have been subjected to repairs or attempted repairs by any person other than Compatible Systems (or an authorized Compatible Systems service technician).

To obtain service under this Warranty, the Customer (or subsequent purchaser, if applicable) must follow the procedures outlined below, under "Product Return Policy."

THE WARRANTIES SET FORTH IN THESE TERMS AND CONDITIONS ARE IN LIEU OF ALL OTHER WARRANTIES, EXPRESSED OR IMPLIED. WITHOUT LIMITATION ON THE GENERALITY OF THE FOREGOING SENTENCE, COMPATIBLE SYSTEMS EXPRESSLY DISCLAIMS AND EXCLUDES ALL IMPLIED WARRANTIES OF MERCHANTABILITY AND OF FITNESS (GENERALLY OR FOR A PARTICULAR PURPOSE).

2. **Shipments.** All delivery indications are estimated and are dependent in part upon prompt receipt of all necessary information to service an order. Compatible Systems shall not be liable for any premium transportation or other costs or losses incurred by Customer as a result of Compatible Systems inability to deliver Product in accordance with Customer's requested delivery dates. All shipments by Compatible Systems are made F.O.B. factory (Boulder, Colorado); risk of loss shall pass to Customer at point of shipment. Unless specified by the Customer, Compatible Systems will select the mode of transportation for each order. Compatible Systems reserves the right to make deliveries in installments. Partial shipments