

CISCO SYSTEMS

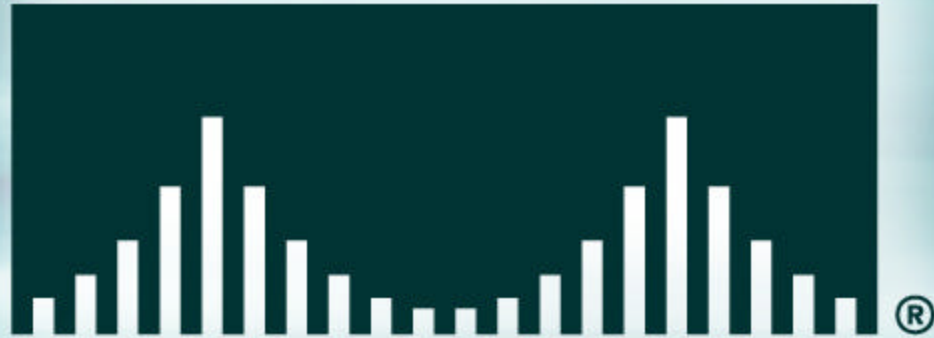

WLAN Product Update

Mark Tomasheski
Cisco WW Channels
Solutions Engineer

Agenda

Cisco.com

- **WLAN Technologies**
- **1200 Series Dual mode product**
- **1100 Series and Software enhancements**
- **Product Positioning**

WLAN Technologies

Wireless LAN Technologies

Cisco.com

	802.11b	802.11a	802.11g
Frequency Band	2.4 GHz	5 GHz	2.4 GHz
Availability	Worldwide	N.A. and AP	Worldwide
Maximum Data Rate	11 Mbps	54 Mbps	54 Mbps

The Laws of Radio Dynamics:

Higher data rates = shorter transmission range
Higher power output = increased range, but lower battery life
Higher frequency radios = higher data rates, shorter ranges

Unlicensed Spectrum Overview

- Various unlicensed frequency bands
- Mobile—low data rate
- Fixed—high data rate
- Spread spectrum
- Residential, SOHO, and small/medium business
- Multi-sectored node sites
- Up to 6 miles in multipoint, 15 miles in point-to-point

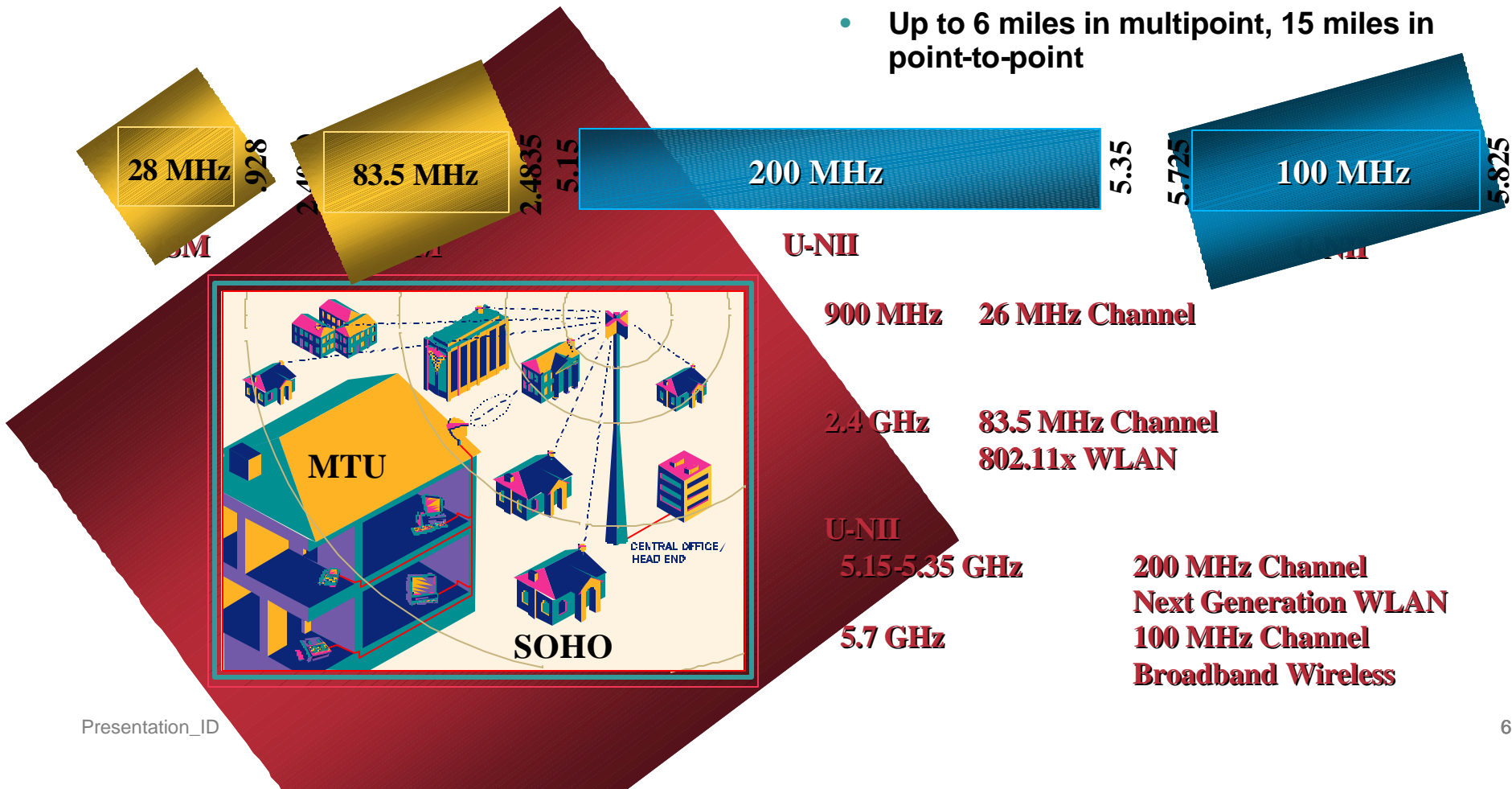

Comparing the Technologies

Understanding the 5 GHz Spectrum

Cisco.com

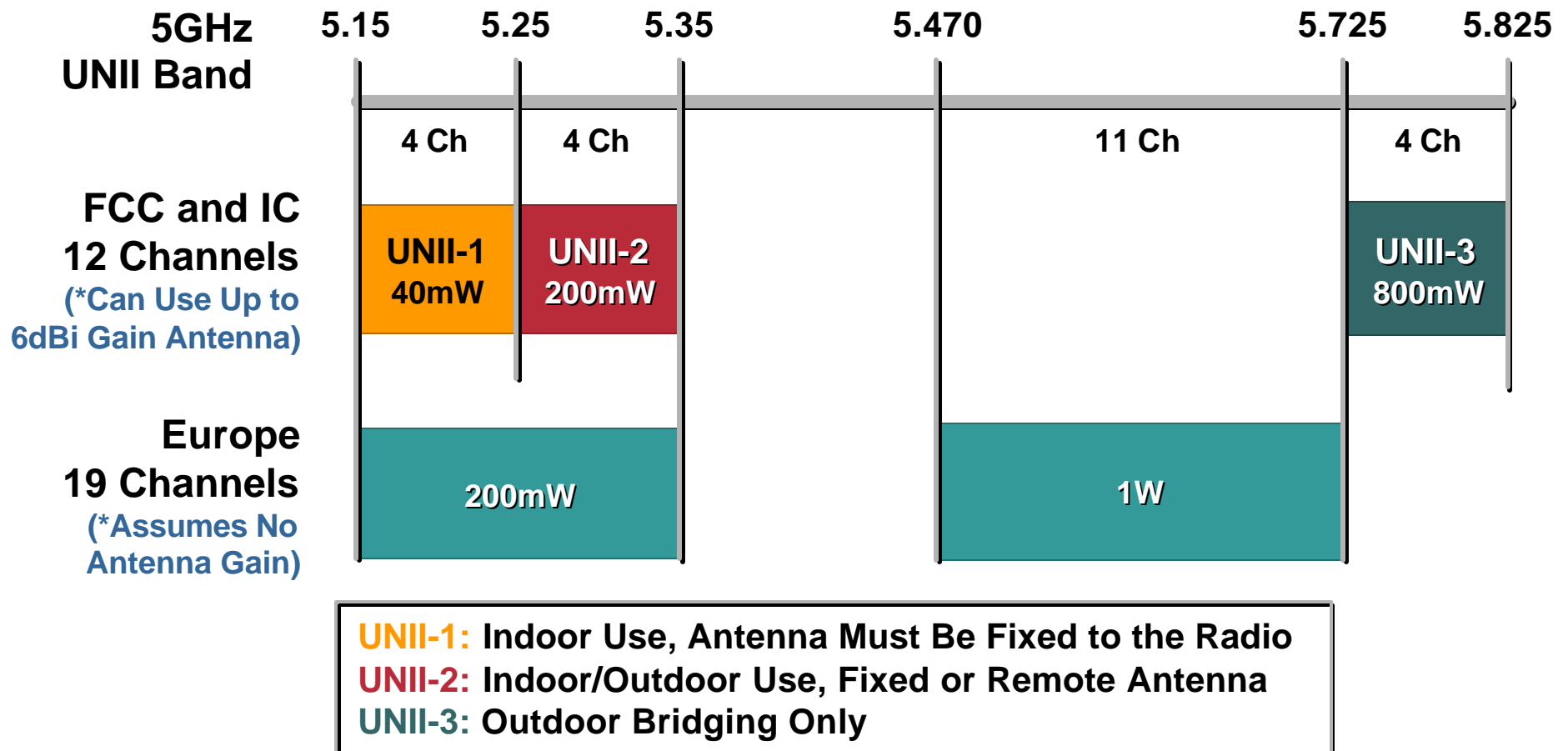

***If You Use a Higher Gain Antenna, You Must Reduce the Transmit Power Accordingly**

IC/FCC 5 GHz specifications

IC/FCC regulations for UNII-1 and UNII-2

- 50 mW UNII-1 vs. 40 mW (2.5 mW/MHz) 802.11a
- 250 mW UNII-2 vs. 200 mW (12.5 mW/MHz) 802.11a
- If the radio can Tx @ UNII-1 band then it must adhere to UNII-1 emissions @ UNII-2 band
- If the radio can Tx @ UNII-1 band then it must use the UNII-1 antenna for UNII-2 band
- UNII-1 is indoors **only!!** UNII-2 is indoor or outdoors
- Transmit power UNII-1 17dBm, UNII-2 24dBm

802.11a- 5 GHz/54Mbps

- **Ratified as Standard in September, 1999**
- **Provides similar technology to HyperLAN2**
- **Data rates to 54 Mbps defined**
- **Provides 8 indoor WLAN channels**
- **Regulation differ extensively across countries**

Characteristics of 802.11a

Cisco.com

- **Orthogonal Frequency Division Multiplexing (OFDM)**
 - Data rates supported: 54, 48, 36, 24, 12, and 6 Mbps
 - Can “downshift” to lower data rates for longer range
 - 802.11a will have greater avg. throughput than 802.11g since 802.11a has no backward compatibility requirement
- **Worldwide compatibility issues for 5 GHz band**
 - Cisco’s 802.11a is currently approved for indoor AP use in these countries:
www.cisco.com/go/aironet/compliance
 - Effort underway to allow 802.11a operation in European countries
 - Long-term: Worldwide usage with adoption of Transmit Power Control (TPC) and Dynamic Frequency Selection (DFS) per 802.11h standard
- **5 GHz band has more channels than 2.4 GHz band**
 - UNII-1 + UNII-2 = 8 non-overlapping channels (vs. 3 channels for 2.4GHz)
- **5 GHz band subject to less interference than 2.4 GHz ISM band**
 - However, 2.4 GHz interference not a major problem in most business environments

802.11a UNII-1 & UNII-2 ISM Channels

Cisco.com

HIGH-SPEED PHYSICAL LAYER IN THE 5 GHz BAND

IEEE
Std 802.11a-1999

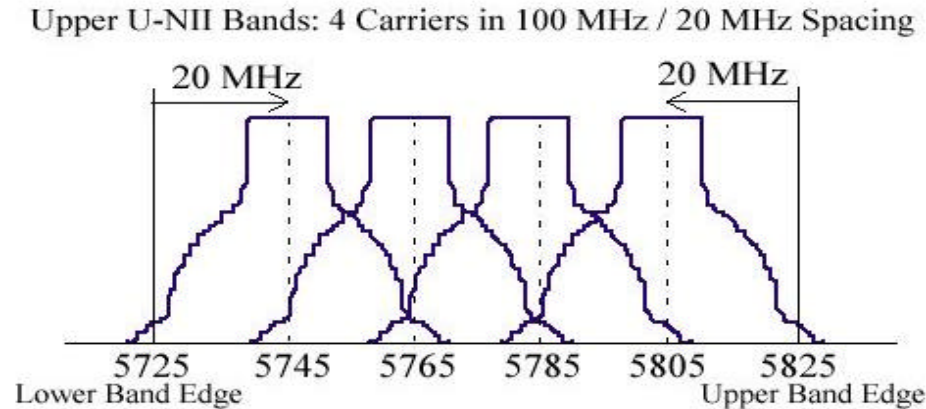
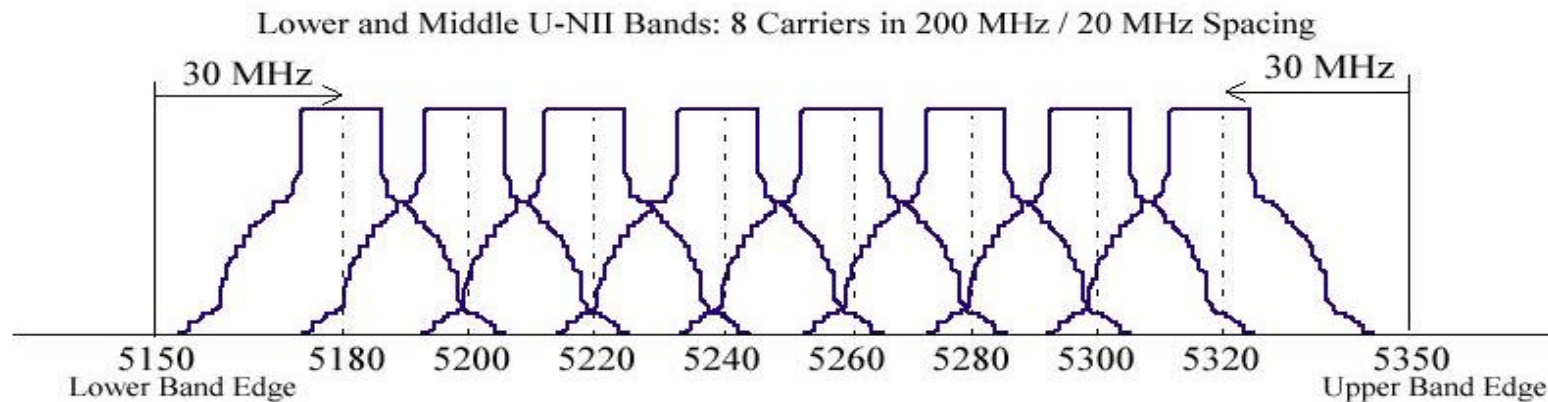

802.11b- 2.4Ghz/11Mb

- **Ratified as Standard in September, 1999.**
- **11 Mbps 2.4 GHz**
- **14 defined Channels**
- **Power levels**
 - 36 dBm EIRP-IC/FCC**
 - 20 dBm EIRP-ETSI**
- **Virtually approved for world wide use.**

IEEE802.11g

Standard for Higher Rate (20+ Mbps) Extensions in the 2.4GHz Band

Cisco.com

- Provides **higher data rates @ 2.4 GHz**
- **Similar speeds** as 802.11a
- **Backward compatible** with 11 Mbps (802.11b)
- Same modulation as 802.11a—**OFDM**
- Estimated to complete specification in early 2003

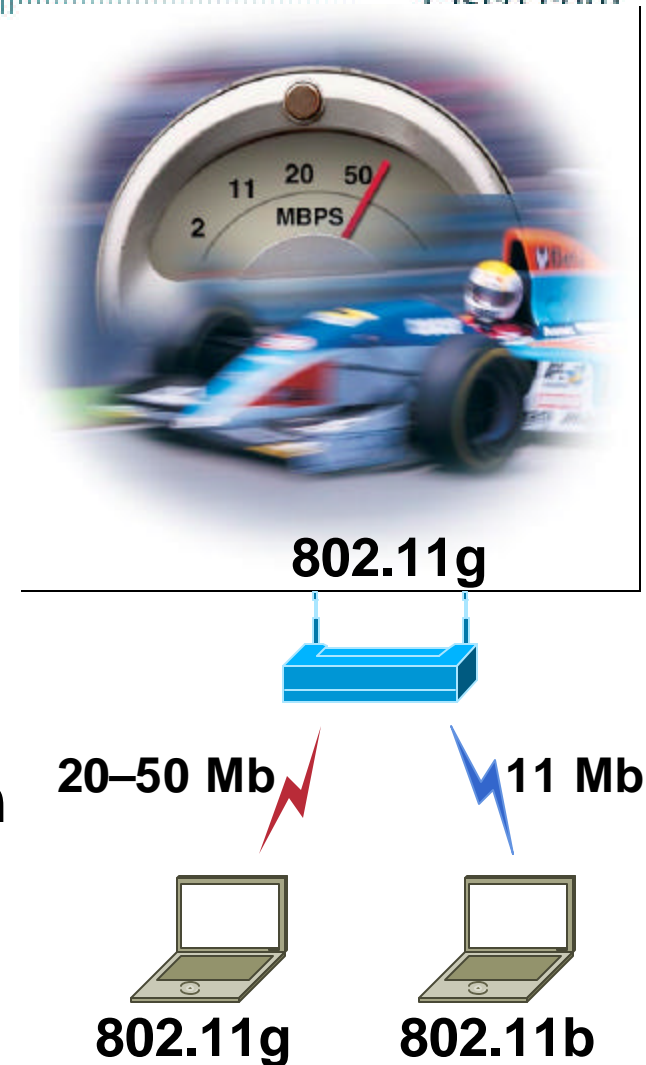

802.11h

Spectrum Managed 802.11a

- **Still in Draft mode**
- **Dynamic Frequency Selection (DFS)**
 - Enables transmitter to move to another channel when it encounters other RF on its channel.
- **Transmit Power Control (TPC)**
 - Provides minimum required transmitter power for EACH user
 - Provides minimal interference to any other users or system
- **Required for ETSI for 5 GHz**
 - Europe/Asia/South America and others

Dual Mode products

Cisco.com

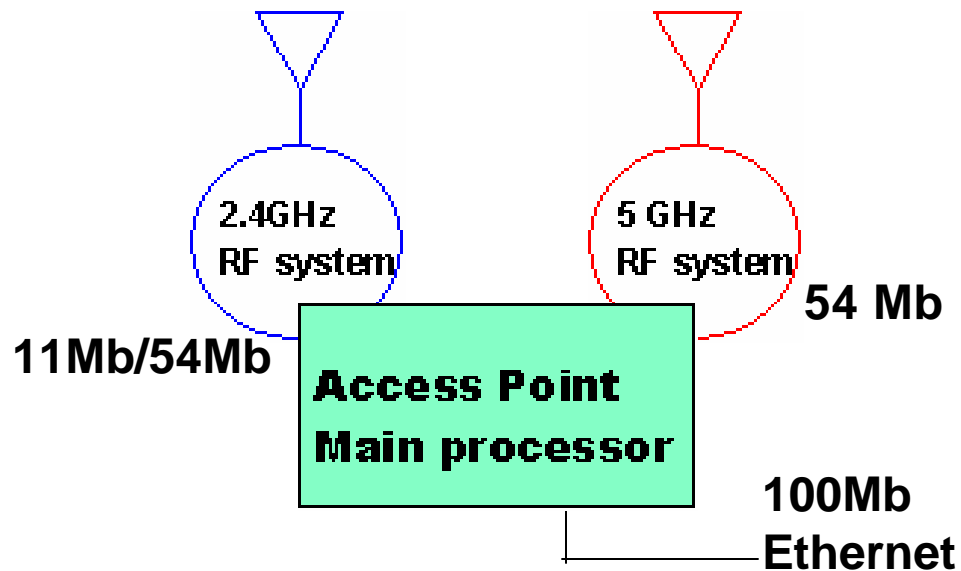

- **Dual Band Access points are available now**
- **Must provide processor power to grow**
- **Provides access and coverage for both 2.4 and 5Ghz clients simultaneously.**
- **Can be used to increase aggregate bandwidth per cell**

Cisco's WLAN Product Evolution

Cisco.com



340 Series

- 30 mW radio
- AC powered

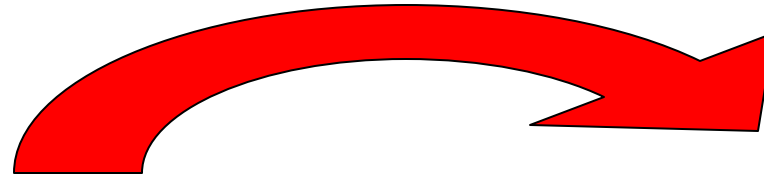

350 Series

- 100 mW radio
- In-line powered
- Improved motherboard
- Plenum ratable

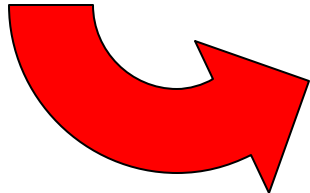

1100 and 1200 Series

- Modular design
- 802.11a and/or b radios
- .11g radios shortly
- AC powered or in-line
- Plenum ratable

AP1200 Series

Performance

- **802.11b radio**

 - Same radio performance as the 350 Series AP**

 - 100 mW radio**

 - Built-in RP-TNC connectors for diversity**

 - Wide range of Cisco 2.4 GHz antennas offered**

- **802.11a radio**

 - Delivers up to 54 Mbps, the next generation of performance**

 - Can run in dual mode capacity with the 802.11b radio**

 - Innovative antenna design to fit deployment needs**

Investment Protection

Hardware Features

- **Modular platform for single or dual band operation**
- **Processor: 282 MIPS @ 200 MHz**
- **SDRAM: 16 MB**
- **Flash: 8 MB**
- **Field upgradable radios**



Investment Protection

Dual band capabilities

Cisco.com

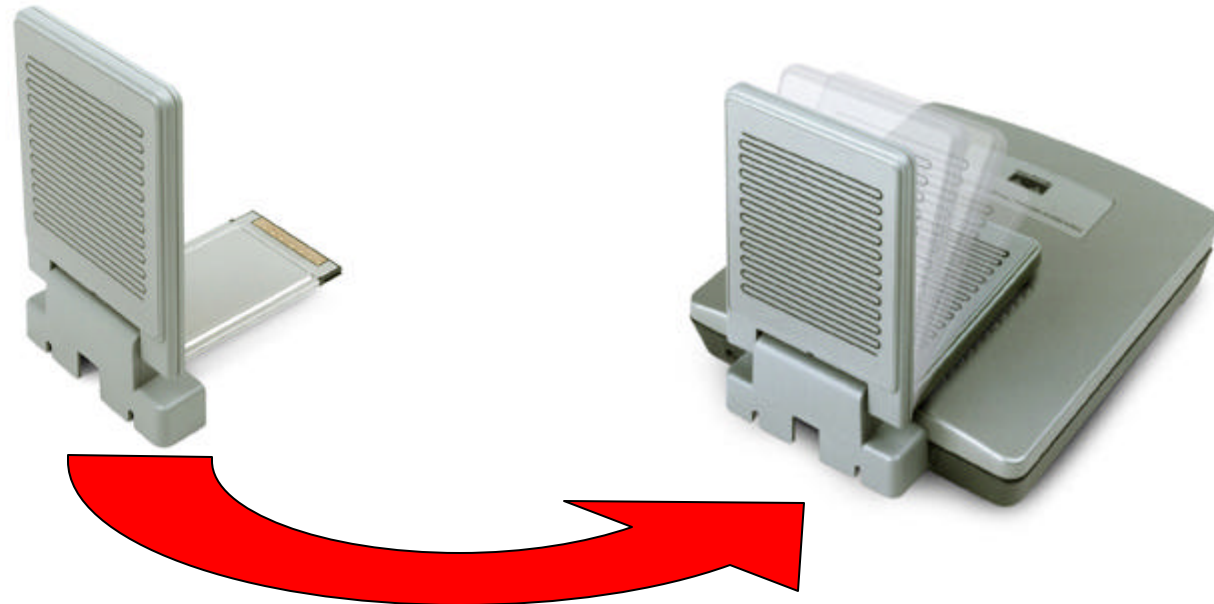

- **Module slot for 802.11a radio**
- **Will be able to run both 802.11b and 802.11a simultaneously**

802.11a 5 GHz Access Point Radio Module

Cisco.com

- **5 GHz – UNII 1 and UNII 2 indoor compliant**
- **Most regulatory agencies require the radio, antenna, and AP to be a single unit**
- **40 mW radio**
- **Data rates 54 mbps to 6 mbps**
- **Two 5 GHz diversity antennas**



Investment Protection Mounting



- **Mounting bracket separate from AP**
- **Kensington lock port**
- **Pad lock holes lock-in AP to mounting bracket as well as the 802.11a module**
- **AP when attached to mounting bracket hides the mounting screws for enhanced security**

Flexibility



- **Rugged design and plenum rated**
 - **Max operating temperatures: -20 to +55°C**
- **Multiple mounting options: wall, ceiling, desktop. Secure with cable lock or padlock.**
- **Flexible power options: Inline power from 48V power capable switch, Power injector OR local power supply**

Flexibility

Field Upgradeable

Cisco.com



Mini-PCI 2.4
GHz slot



Radio
Module slot

- **Both the 2.4 GHz and 5 GHz radios are field upgradable**

1200 Series Components

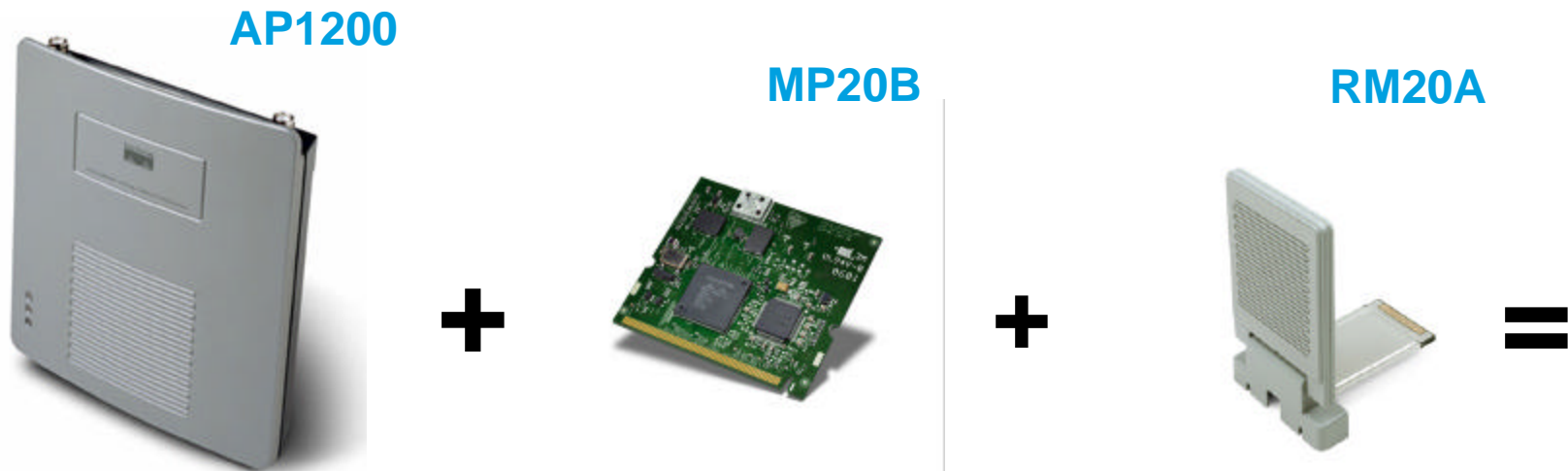

A user configurable access point capable of simultaneous 802.11a and 802.11b support.

Other Key Features

Console port



Console Port

- Not using non-standard DB-9 console port
- Using standard Cisco rollover cable for console
- Port is RJ45 connector, without the LEDs

Other Key Features

In-line power

Cisco.com



- **New power injector works on both 350 and 1200**
- **350 power injector will not work with 1200**
- **3524 powered switch will power a single radio on the 1200, but not 2 radios at the same time**

Clients for Use with Cisco Aironet 1200 Series Access Point

Cisco.com

- In a break with past part numbering practices, we will no longer have client part numbers that “align” with AP part numbers

Recognizes that 802.11 market has matured

The only “alignment” is based on protocol (.11a, .11b)

e.g. all 802.11b clients will work with all 802.11b AP's

- The AP1200 works with the following Cisco clients:

AIR-PCM352 (802.11b, PCMCIA)

AIR-MPI350 (802.11b, Mini-PCI)

AIR-WGB350 (802.11b, Workgroup Bridge)

AIR-PCI352 (802.11b, PCI Adapter)

AIR-CB20A (802.11a, CardBus)



5 GHz NIC Main Features

- **Rate Shifting**
6, 9, 12, 18, 24, 36, 48, or 54.
- **Fixed Data Rates**
User configurable option
- **5 dBi Patch Antenna**
- **CardBus interface**



5 GHz NIC Additional Features

Cisco.com

- **WEP 128 Encryption in hardware**
- **802.1x Support**
LEAP, EAP-TLS, PEAP, EAP-TTLS
- **3 Transmit power settings: 20mW, 10mW, 5mW**

Cisco Aironet 1200 Series Target Markets

Cisco.com

- **Flagship of product line**
- **Enterprise market >1000 employees**
- **Specialty applications**
 - When external antennas needed
 - When extreme temperature range is required
- **Vertical markets**
 - Healthcare and Higher Education
 - Budget, bandwidth requirements
- **Any company requiring greater than 11 Mbps for their applications**

Range Comparisons

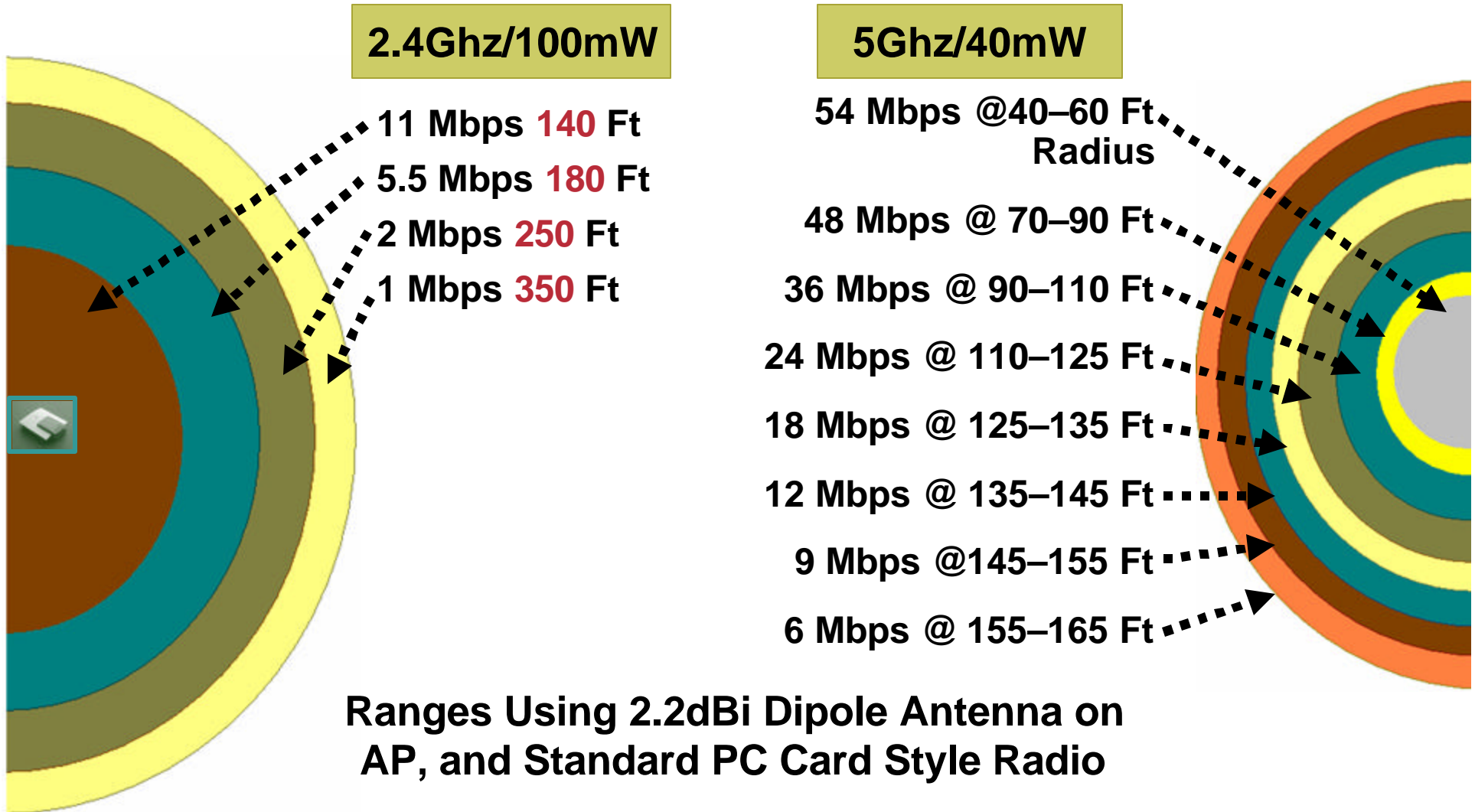

Ranges Using 2.2dBi Dipole Antenna on AP, and Standard PC Card Style Radio

AP1100 Series

Enterprise WLAN Requirements

Cisco.com

- **Scalable**
 - Support for any type roll out plan
 - Support for any size deployment
- **Affordable**
 - High value with low upfront cost
 - Low total cost of ownership (training, manageability)
 - Investment protection
- **Enterprise-class features**
 - Intelligent services expected on *wired* LANs; delivered on wireless LANs
- **Secure**
 - Wireless data protection equal to, if not greater than wired LANs
- **Easy-to-use**
 - Straight-forward deployment
 - Intuitive and familiar interfaces

Cisco Aironet 1100 Series Access Point

Cisco.com

- **Scalable**

Fully functional access point ideal for all enterprise deployments without expensive controllers

- **Affordable**

Lowest priced upgradable Cisco Aironet access point protects customer investment

- **Enterprise-class features**

End-to-end intelligent networking extended to WLAN

- **Secure**

Enterprise-class interoperable security for WLAN

- **Easy-to-use**

Intuitive installation and set up for rapid deployment



***Intelligent enterprise services
at a lower total cost***

Cisco Aironet 1100 Series Access Point Scalability

Cisco.com

- **Autonomous functionality, management, and security**

Stand alone intelligent WLAN solutions scale as your network requirements grow

- **Enterprise management for large scale deployments**

Remote configuration and firmware upgrade support

BOOTP, DHCP, Telnet, FTP, TFTP for centralized management

SNMP – compliant network management software support

MIB I and MIB II support for high integration with existing network management tools

Integrated into CiscoWorks – CiscoView, Resource Manager Essentials (RME) and Campus Manager

Cisco Aironet 1100 Series Access Point

Investment protection

Cisco.com

- **Protects current client investment**
Single 802.11b radio standard
- **Future-proof for tomorrow's technologies**
Upgradable to 802.11g for higher performance and more robust AES security encryption (when available)
- **Extra system capacity**
More than twice today's current memory requirements for future enhancement support
- **List Price of \$599 USD**
Priced to fit most any enterprise budget

Cisco Aironet 1100 Series Access Point

Affordability

Cisco.com

- **Single 802.11b radio**
 - Time-tested technology
 - Supports installed client-base
- **Upgradable**
 - Migration path to 802.11g for further investment return
- **Extra system capacity**
 - More than twice today's current memory requirements for future enhancements

Cisco Aironet 1100 Series Access Point

Enterprise-class Features

Cisco.com

- **Cisco IOS**
 - End-to-end intelligent network services
 - Familiar service configuration and network behavior
- **VLANs**
 - Network segmentation for flexible policy and service application
- **QoS**
 - End-to-end prioritization for applications such as voice and video
- **Proxy Mobile IP**
 - Seamless inter-subnet roaming

Cisco Aironet 1100 Series Access Point Security

Cisco.com

- **Standards-based 40-bit 128-bit WEP**
For highest interoperability
- **Cisco Wireless Security Suite**
Award-winning enterprise security
802.1x, EAP-based mutual authentication
Dynamic, per-user, per-session key rotation
Pre-standard TKIP
- **VLANs**
Differentiated access to support a non-deterministic client base

Cisco Aironet 1100 Series Access Point

Simplified Deployment

Cisco.com



- **Integrated diversity dipole antennas and flexible mounting system**

Supports installation in any orientation and location such as ceilings, walls, cubicles and desktops

- **UL 2043 certified**

Allows for installation in plenum air spaces

- **In-line Power**

Eliminates local AC power requirements for lower total cost of ownership

Cisco Aironet 1100 Series Access Point Powering Options

Cisco.com

- **Local Power**

Included 48VDC power supply

- **Inline Power**

Optional Power Injector (ordered separately)

AIR-PWRINJ2

Powering Switch

Catalyst 3524-PWR XL

Catalyst 4000 chassis and inline power line cards

Catalyst 6500 chassis and inline power line cards

Catalyst Inline Power Patch Panel



Bottom panel

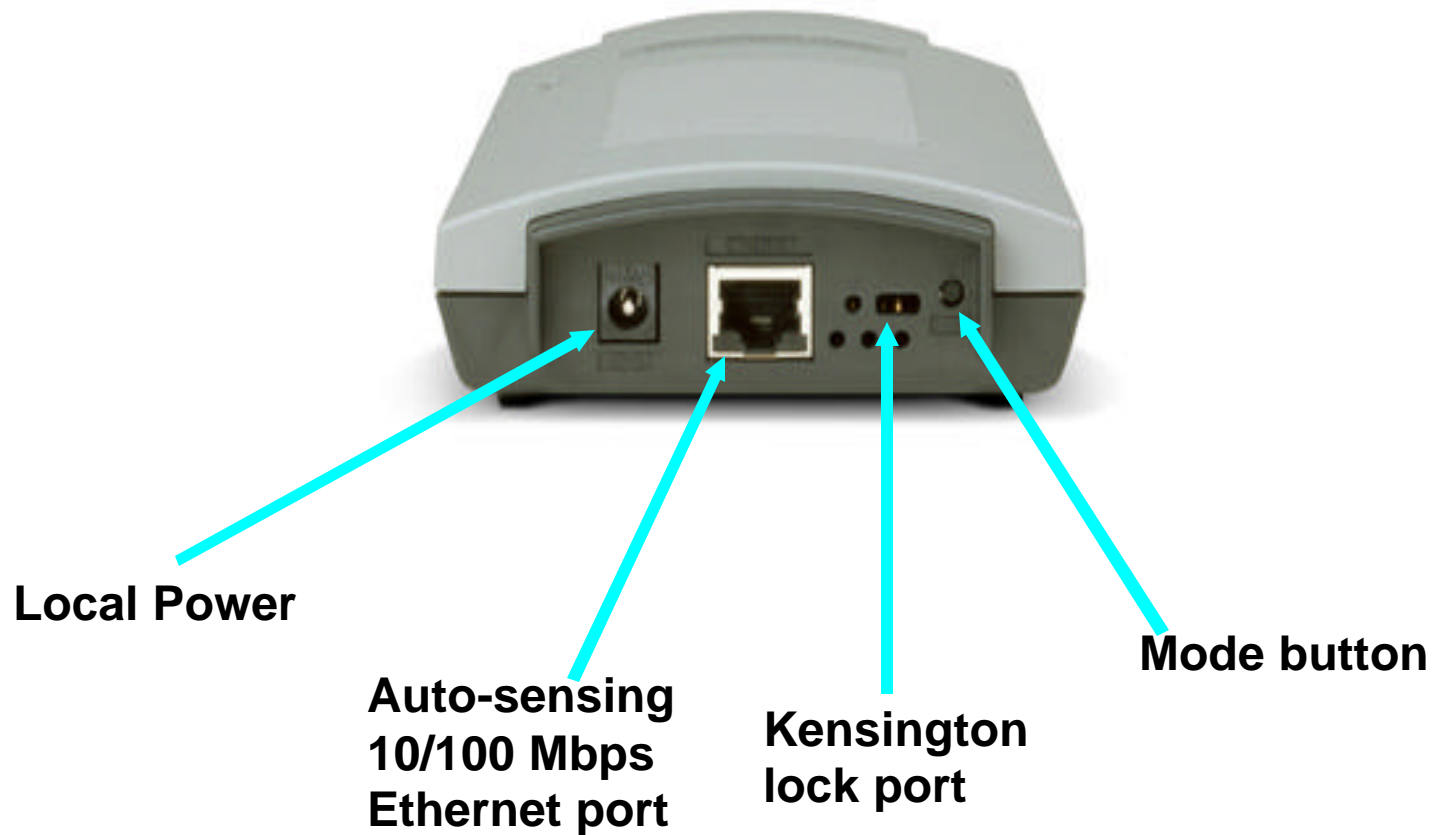

AP1100 Browser Interface

Note: Mixing configuration settings using the GUI and CLI may result in inconsistent behavior and so is not recommended.

The screenshot displays the Cisco 1100 Access Point browser interface. At the top, there is a 'Close Window' button and the Cisco Systems logo. The main title is 'Cisco 1100 Access Point'. Below the title, a navigation menu on the left includes options like HOME, EXPRESS SET-UP (highlighted), NETWORK MAP, ASSOCIATION, NETWORK INTERFACES, SECURITY, SERVICES, SYSTEM SOFTWARE, and EVENT LOG. The main content area shows the 'Express Set-Up' configuration page for the device 'AP1100'. The page indicates that the AP1100 uptime is 3 days, 15 hours, and 10 minutes. The configuration fields include: System Name (AP1100), MAC Address (0005.9a39.2110), Configuration Server Protocol (Static IP selected), IP Address (10.91.6.159), IP Subnet Mask (255.255.255.192), and Default Gateway (10.91.6.129). The SSID field is noted as having multiple SSIDs set and must be edited with Security-SSID. The Role in Radio Network is set to Access Point Root, and the Optimize Radio Network for is set to Throughput.

AP1100 IOS Interface

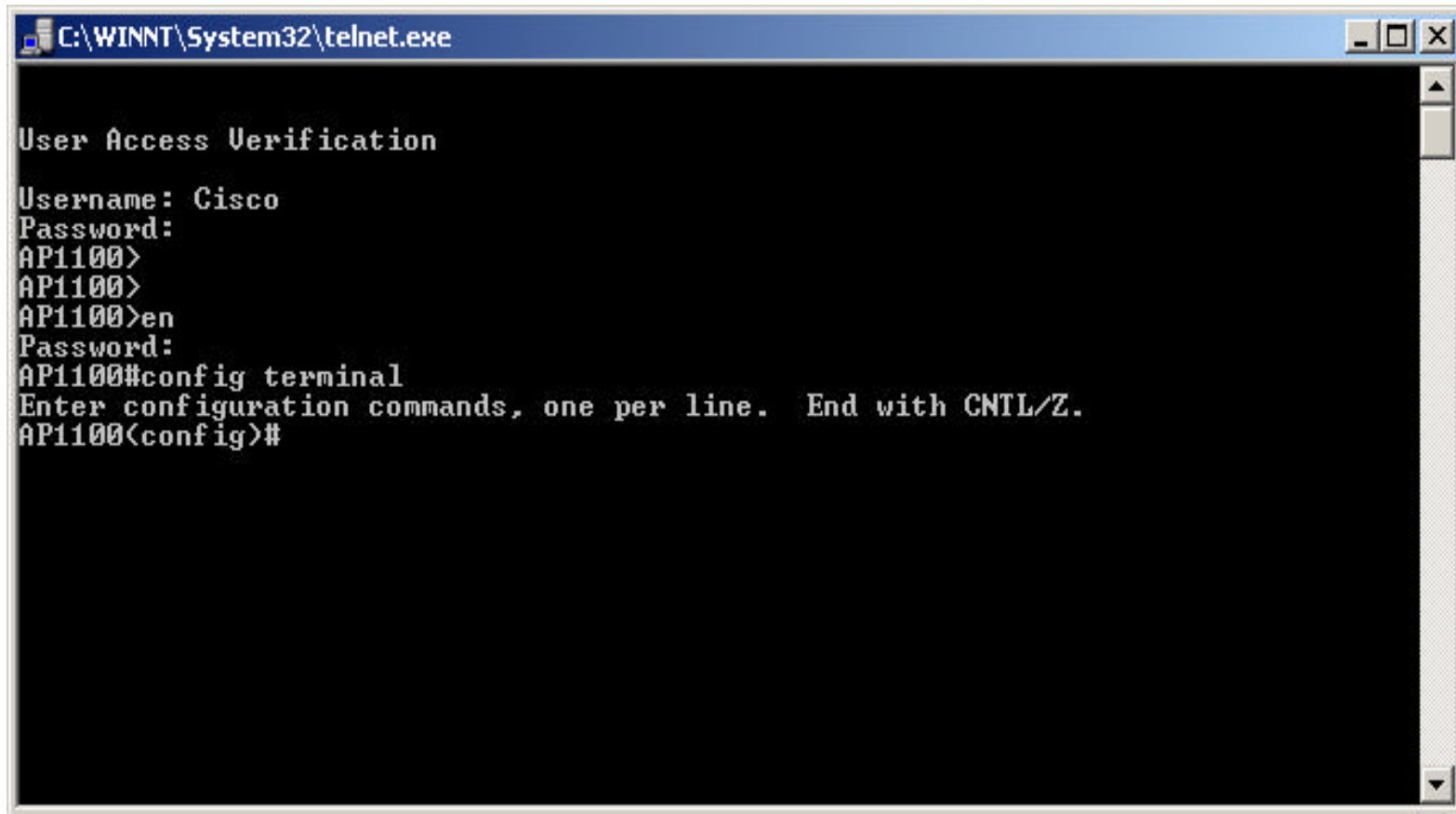
A screenshot of a Windows telnet window titled "C:\WINNT\System32\telnet.exe". The window shows a telnet session with the following text:

```
User Access Verification
Username: Cisco
Password:
AP1100>
AP1100>
AP1100>en
Password:
AP1100#config terminal
Enter configuration commands, one per line. End with CNTL/Z.
AP1100(config)#
```

VLAN

Wired implementation

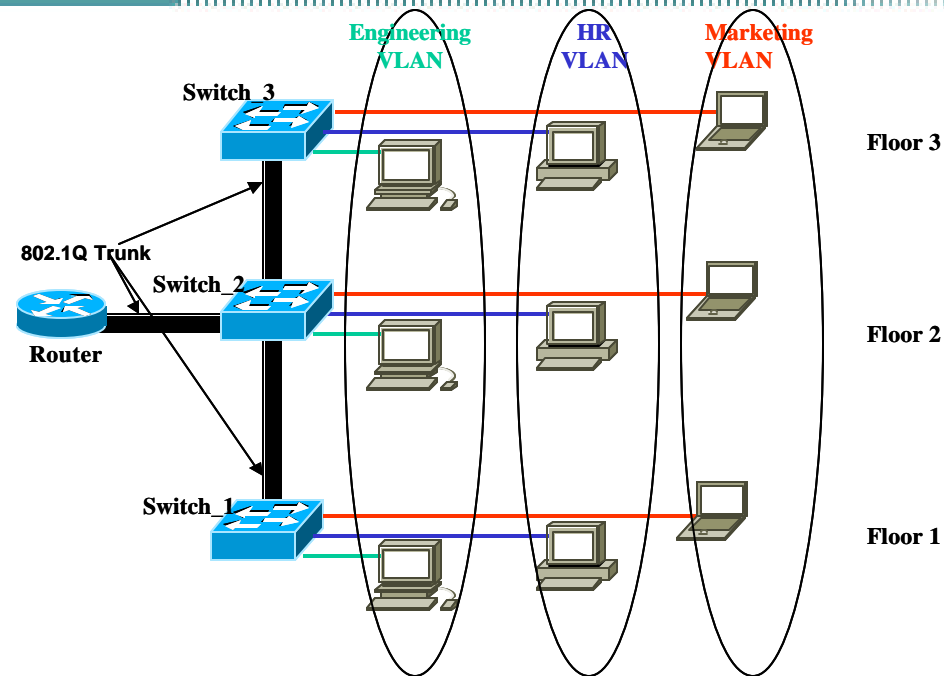

A VLAN is a group of end stations with a common set of requirements, independent of their physical location. A VLAN has the same attributes as a physical LAN but allows you to group end stations even if they are not located physically on the same subnet.

VLAN

Wireless implementation

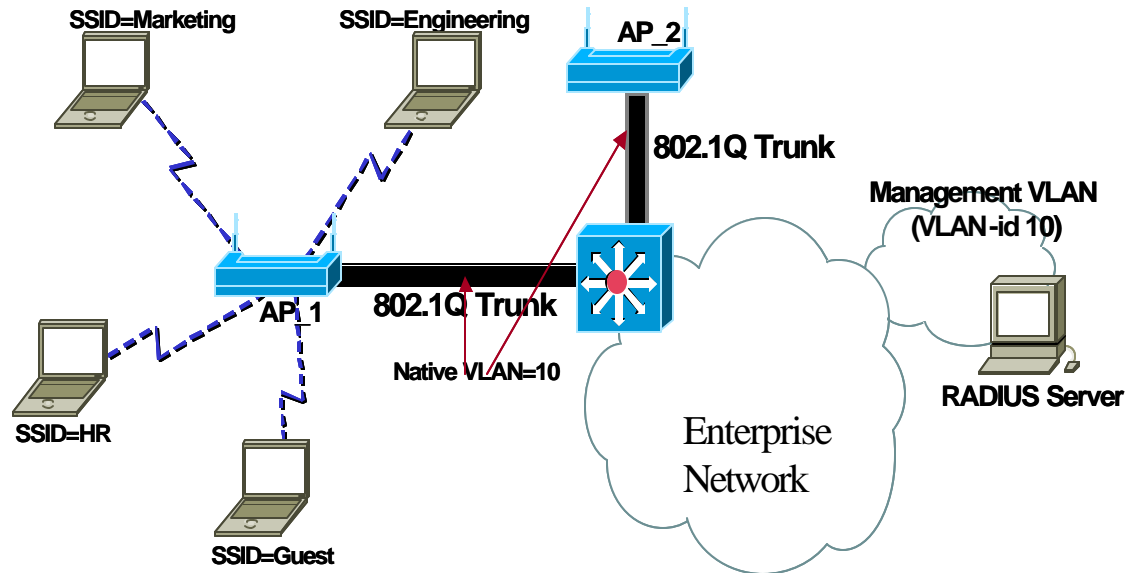

SSID	VLAN-id	Security Policy	Radius VLAN override (optional per user basis)
Engineering	14	802.1x with Dynamic WEP + TKIP	yes
Marketing	24	802.1x with Dynamic WEP + TKIP	yes
HR	34	802.1x with Dynamic WEP + TKIP	no
Guest	44	Open/no WEP	no

Proxy Mobile IP- problem & solution

Cisco.com

- **Mobile IP was created to enable users to keep the same IP address while traveling to a different networks thus ensuring that a roaming user could continue communication without sessions or connections being dropped.**
- **Proxy Mobile IP was created to provide the exact same Mobile IP functionality to the users without them having to have any Mobile IP-capable software running on their client devices.**
- **Proxy Mobile IP software runs on the AP therefore it supports typical wireless clients.**
- ***Note: Mixing Proxy Mobile IP configuration on VLANs is not supported at this time.***

Proxy Mobile IP Topology

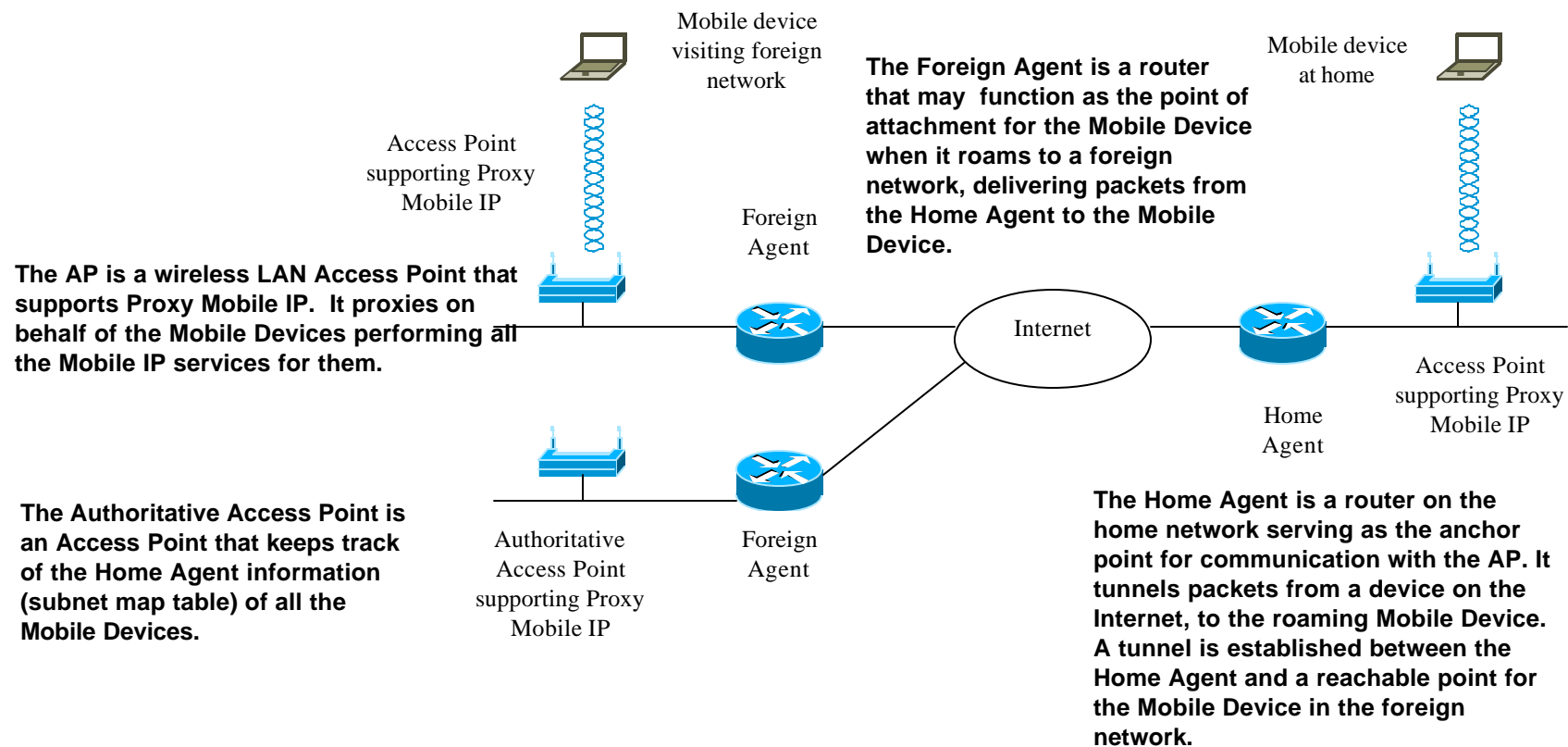

Target Markets

Cisco.com

- **Value line**
 - Enterprise features at affordable price**
- **Mid-Market 500-1000 employees**
- **Enterprise**
 - Budgetary, branch offices**
- **Verticals**
 - healthcare, (satellite branches)**
 - Education (budgetary, ease of deployment)**

AP comparison

Cisco.com

	350 Series	1100 Series	1200 Series
IOS	Q3CY03	X	Q1CY03
VxWorks	X		X
Mobile IP		X	
QoS support	Q4CY02	X	Q4CY02
VLAN support	Q4CY02	X	Q4CY02
.11a Capable			X
.11g Capable		X	X
2.4 GHz Antenna	Removable	Fixed	Removable

Product Positioning

Cisco's 2-Tier AP Roadmap

Cisco.com

Performance Line



Cisco Aironet 350 Series (.11b)



- Cisco Aironet 1200 Series Access Point
- Built-in .11b module



- .11a AP Module with High Gain Antenna
- .11a PC Card (Card Bus)



- upgradable
- .11g AP Module

2001

2002

2003

Value Line



- Cisco Aironet 1121 Series Access Point
- Built-in .11b module

Cisco Aironet WLAN Access Point Comparison

Cisco Aironet 1100 Series	Cisco Aironet 1200 Series
Intelligent Enterprise Services at a Lower Total Cost	Outstanding Enterprise Performance and Greatest Flexibility
Single 802.11b radio (upgradable to 802.11g with AES)	Dual-mode 802.11a and 802.11b support (upgradable to 802.11g with AES)
Integrated diversity dipole antennas for simplified deployment	Two 2.4 GHz antenna connectors for high gain diversity antennas; integrated 5 GHz antennas
Indoor environmental specifications, durable plastic case	Industrial environmental specifications, rugged metal case
Extra memory and system capacity for future releases	Extra memory and system capacity for future releases
Inline and Local Power	Inline and Local Power
Cisco IOS-based operating system	Upgradable to Cisco IOS operating system
QOS, VLANs, and Proxy Mobile IP	Upgradable to QOS, VLANs, and Proxy Mobile IP

5 GHz Advantages

- **Performance**
- **Capacity (# of channels)**
- **Scaleable (6-54 Mbps, many channels)**
- **Interference avoidance (Bluetooth resistant)**

Market Positioning

- **.11b is ideal for customers:**
 - Requiring lowest acquisition cost
 - That have a large installed base of .11b
 - That have lots of roaming users (to other .11b sites)
- **.11a is ideal for customers:**
 - Requiring higher data rates
 - Requiring greater capacity (more channels)
 - Concerned about interference
 - With a small installed base of .11b

CISCO SYSTEMS



EMPOWERING THE
INTERNET GENERATION