

THIS IS THE POWER OF THE NETWORK. **now.**



CISCO PRODUCT GUIDE

SMARTER WAYS OF NETWORKING

CISCO SYSTEMS, THE **WORLDWIDE LEADER** IN END-TO-END NETWORKING SOLUTIONS, PROVIDES THE BROADEST RANGE OF SOLUTIONS FOR **TRANSPORTING DATA, VOICE, AND VIDEO**, WITHIN BUILDINGS AND OFFICES AROUND THE WORLD.

TODAY, NETWORKING SOLUTIONS ARE AN ESSENTIAL PART OF BUSINESS. CISCO CAN HELP ASSURE THE **HIGHEST LEVELS OF SECURITY, RELIABILITY, AND PERFORMANCE**, BECAUSE THE SAME CISCO TECHNOLOGY THAT IS POWERING THE VAST MAJORITY OF TODAY'S BUSINESS NETWORKS WORLDWIDE IS ALSO POWERING OURS.

END-TO-END SOLUTIONS

CISCO OFFERS ROUTERS, SWITCHES, SECURITY DEVICES, VPNs, WIRELESS LANs (WLANs), AND THE SOFTWARE NECESSARY TO INTEGRATE EACH ELEMENT INTO A SECURE, PRODUCTIVE, RELIABLE, AND EASY-TO-MANAGE NETWORK. THIS UNIQUE END-TO-END SOLUTION PROVIDES THE SIMPLICITY EVERY BUSINESS NEEDS.

- **Integrated, end-to-end security**—To safeguard confidential business data, a Cisco network provides enhanced security that protects the network from internal and external threats. An integrated security solution also simplifies security management and greatly reduces the total cost of ownership of the network.
- **High network availability**—A Cisco network helps ensure the reliable network access and maximum uptime that companies depend on to support new users, open new offices, deploy new services, extend their networks to customers and partners, support a more mobile workforce, and more. Cisco switches and routers include support for network and link redundancy, dynamic routing, automatic failover, and redundant power for improved fault tolerance and network availability.
- **Predictable performance**—Intelligent end-to-end management maximizes the availability and performance of critical applications. Cost-conscious small and medium-sized businesses (SMBs) can maximize WAN bandwidth to serve more users and conduct more business over the Internet without upgrading to more expensive WAN facilities.
- **Ease of use**—Cisco's intuitive end-to-end Web-based management helps keep administrative expenses down—even as the network expands.
- **Cost-effectiveness**—An end-to-end solution approach reduces complexity and network management costs. Modular and scalable products help reduce costs of future expansion.
- **Investment protection**—Customers can receive trade-in value for existing Cisco products against the purchase of new Cisco products.

WIRELESS SOLUTIONS ENABLE PEOPLE TO WORK PRODUCTIVELY, ONSITE, WHILE AWAY FROM THEIR DESKS. CISCO AIRONET® WIRELESS SOLUTIONS:

- Provide secure, affordable, upgradable, and easy-to-use WLAN solutions.
- Deliver industry-leading security with the IEEE 802.1X-based Cisco Wireless Security Suite.
- Support data rates of up to 54 Mbps (IEEE 802.11g) with backward compatibility to 802.11b equipment.
- Make management easy and straightforward.
- Support local power and inline Power over Ethernet (PoE).
- Provide dual-mode support for 801.11a and 802.11g (Cisco Aironet 1200 Series only).

CISCO CATALYST® SWITCHES PROVIDE HIGH PERFORMANCE, INCREASED NETWORK INTELLIGENCE, BETTER CONTROL, AND ENHANCED SECURITY.

Robust and reliable, the switches:

- Provide superior control of traffic to maximise network availability for every user.
- Intelligently allocate priority to critical business applications.
- Provide advanced security to protect vital business data and confidential information.
- Are easy to install and to configure using the intuitive new Cisco Network Assistant.
- Are available in standalone, stackable, or modular configurations.

SECURITY IS AN ISSUE FOR EVERY COMPANY. CISCO SECURITY SOLUTIONS HELP PROTECT YOUR NETWORK FROM INSIDE AND OUT, ENCOMPASSING:

- VPNs, firewalls, access control lists (ACLs), and intrusion detection systems (IDSs) that can be deployed on Cisco routers, switches, and specialised Cisco PIX® security appliances.
- Tools such as Cisco Easy VPN and Auto Update for easy deployment and management.

ROUTERS PROVIDE HIGHLY SECURE, INTELLIGENT ROUTING SOLUTIONS FOR BROADBAND AND LEGACY NETWORKS. CISCO ROUTERS:

- Provide secure firewall and VPN capabilities.
- Span solutions from the service provider and enterprise edge to branch, teleworker, and small offices.
- Offer enhanced performance, support for voice, and additional security features (higher range models).

IP COMMUNICATIONS IS THE CONVERGENCE OF DATA, VOICE, AND VIDEO SOLUTIONS ONTO A SINGLE (IP-BASED) NETWORK.

IP Communications can play a critical part in helping a company to identify new ways to generate revenue, reduce operational costs, increase organisational flexibility, and generate a sustainable competitive advantage.

CISCO CATALYST SERIES SWITCHES — LAYER 2 ACCESS SWITCHES

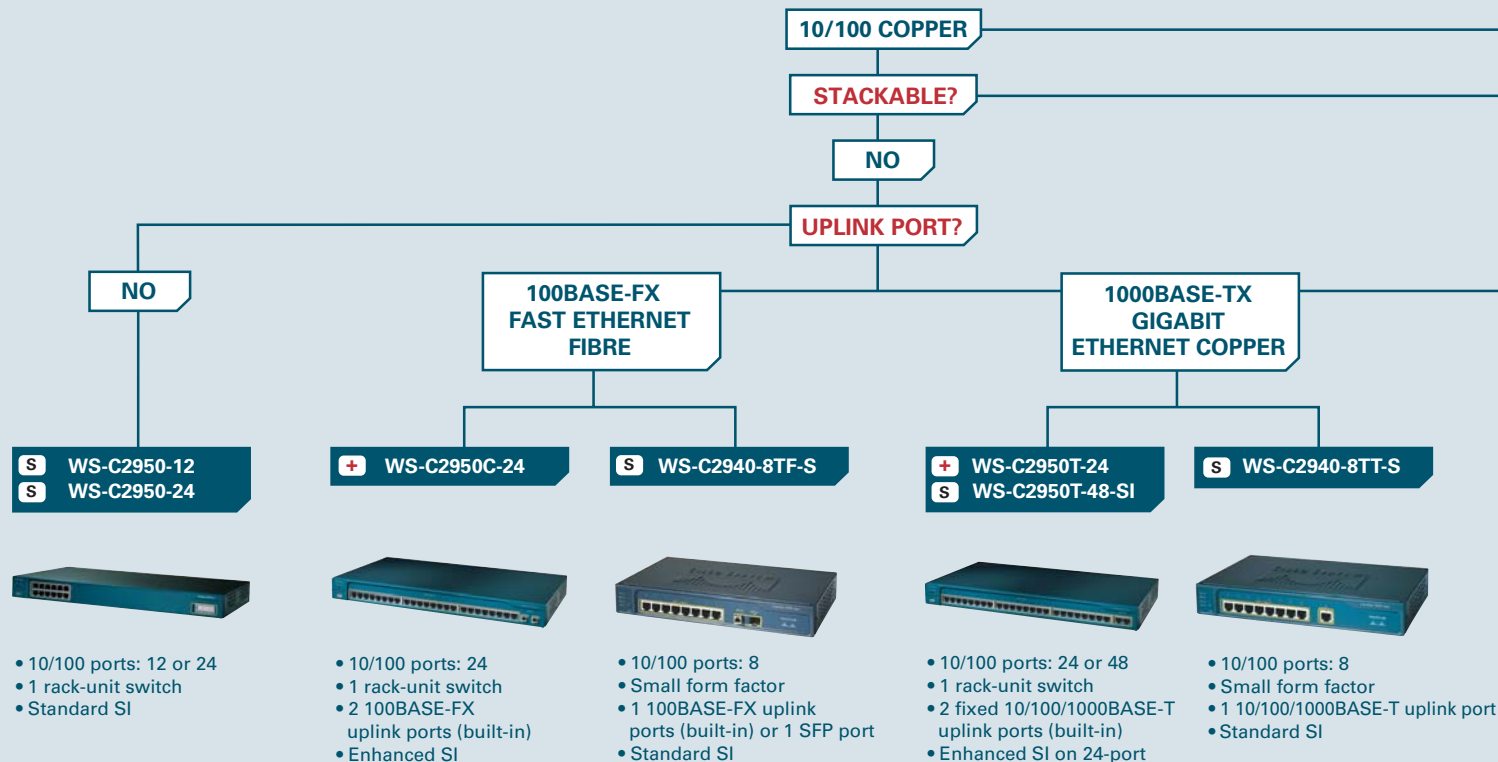

- 10/100 ports: 12 or 24
- 1 rack-unit switch
- Standard SI

- 10/100 ports: 24
- 1 rack-unit switch
- 2 100BASE-FX uplink ports (built-in)
- Enhanced SI

- 10/100 ports: 8
- Small form factor
- 1 100BASE-FX uplink ports (built-in) or 1 SFP port
- Standard SI

- 10/100 ports: 24 or 48
- 1 rack-unit switch
- 2 fixed 10/100/1000BASE-T uplink ports (built-in)
- Enhanced SI on 24-port

- 10/100 ports: 8
- Small form factor
- 1 10/100/1000BASE-T uplink port
- Standard SI

- S** Standard Software Image
- +** Enhanced Software Image—for enhanced security/QoS/routing

LAYER 2 SWITCHING

CONNECTIVITY?

GIGABIT COPPER

NOT STACKABLE

UPLINK PORT?

YES

NO

SFP

1000BASE-SX
GIGABIT
ETHERNET FIBRE

GBIC UPLINK

+ WS-C2970G-24T-E

+ WS-C2970G-24TS-E

upgradable

- S** WS-C2950SX-24
- S** WS-C2950SX-48-SI

- +** WS-C2950G-12-EI
- +** WS-C2950G-24-EI
- +** WS-C2950G-48-EI



- 10/100 ports: 24 or 48
- 1 rack-unit switch
- 2 fixed 1000BASE-SX uplink ports (built-in)
- Standard SI

- 10/100 ports: 12, 24 or 48
- 1 rack-unit switch
- 2 GBIC ports
- Enhanced SI

- 10/100/1000 ports: 24
- 1 rack-unit switch
- Enhanced SI

- 10/100/1000 ports: 24
- 1.5 rack-unit switch
- 4 SFP ports
- Enhanced SI

CISCO CATALYST SERIES SWITCHES – LAYER 2 AND 3 CORE SWITCHES

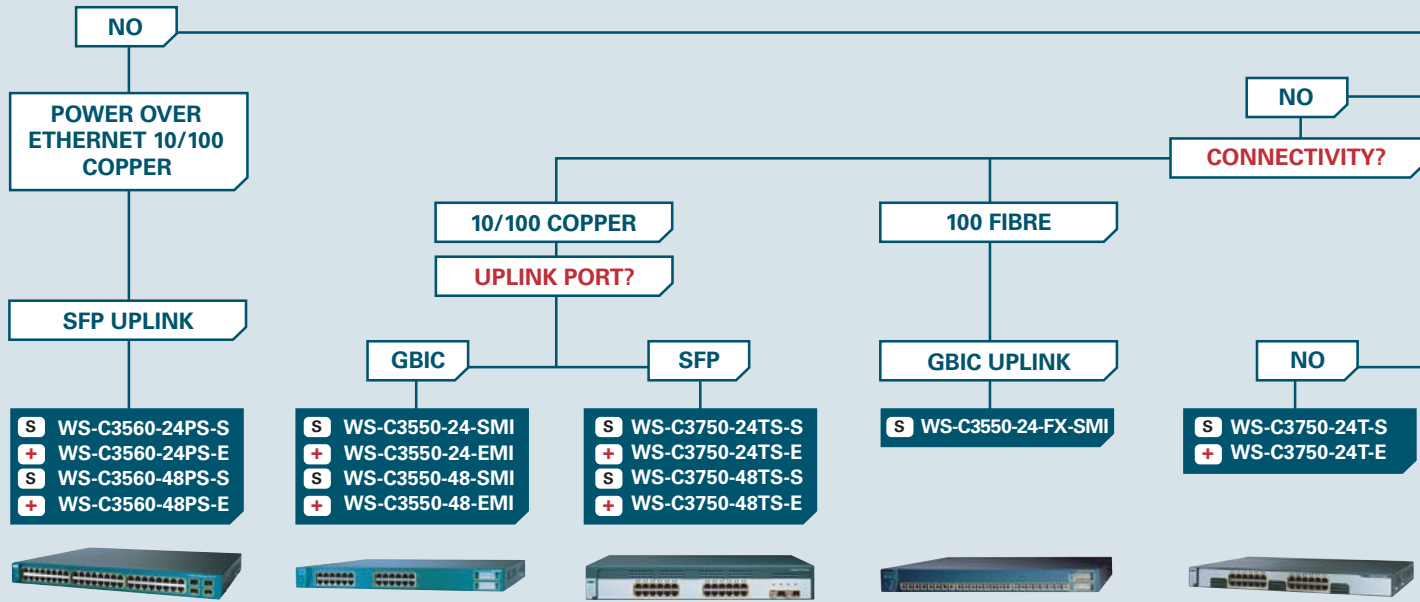

- 10/100 ports with PoE: 24 or 48
- 1 rack-unit switch
- 2 SFP ports (24-port model)
- 4 SFP ports (48-port model)
- Supports IEEE 802.3af PoE standard
- Backward-compatible with Cisco Inline Power standard
- SMI or EMI

- 10/100 ports: 24 or 48
- 1 rack-unit switch
- 2 GBIC ports
- SMI or EMI

- 10/100 ports: 24 or 48
- 1 rack-unit switch
- 2 SFP ports (24-port model)
- 4 SFP ports (48-port model)
- Cisco StackWise™ enhanced stacking capability
- SMI or EMI

- 100BASE-FX multimode fibre ports: 24
- 1 rack-unit switch
- 2 GBIC ports
- SMI or EMI

- 10/100/1000 ports: 24
- 1 rack-unit switch
- Cisco StackWise enhanced stacking capability
- SMI or EMI

- S** Standard Software Image
- +** Enhanced Software Image—for enhanced security/QoS/routing

LAYER 2/LAYER 3 SWITCHING

STACKABLE?

YES

POWER OVER
ETHERNET?

YES

GIGABIT COPPER

GIGABIT FIBRE

10/100 COPPER

UPLINK PORT?

UPLINK PORT?

UPLINK PORT?

SFP

10GE

SFP

SFP

S WS-C3570G-24TS-S
+ WS-C3570G-24TS-E

S WS-C3750G-16TD-S
+ WS-C3750G-16TD-E

S WS-C3750-12S-S
+ WS-C3750-12S-E

S WS-C3750-24PS-S
+ WS-C3750-24PS-E
S WS-C3750-48PS-S
+ WS-C3750-48PS-E

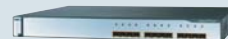

- 10/100/1000 ports: 24
- 1.5 rack-unit switch
- 4 SFP ports
- Cisco StackWise enhanced stacking capability
- SMI or EMI

- 10/100/1000 ports: 16
- 1 10GB uplink
- SMI or EMI

- 12 SFP-based Gigabit ports
- 1 rack-unit switch
- Cisco StackWise enhanced stacking capability
- SMI or EMI

- 10/100 ports: 24 or 48
- 1 rack-unit switch
- 2 SFP ports (24-port model)
- 4 SFP ports (48-port model)
- Supports IEEE 802.3af POE standard Cisco StackWise enhanced stacking capability
- SMI or EMI

CISCO ROUTERS – BROADBAND ROUTING

SMALL OFFICE OR BUSINESS/BRANCH?

SMALL OFFICE

BASIC

BASIC OR ADVANCED SECURITY AND VPN/PERFORMANCE?

ADVANCED

DO YOU HAVE A BROADBAND MODEM?

DO YOU HAVE A BROADBAND MODEM?

YES

NO

YES

NO

CISCO SOHO 91-K9

CISCO SOHO 96, 97-K9

CISCO 831-K9

CISCO 836, 837-K9



- 4-port 10/100 Mbps switch
- Ethernet WAN port
- Cisco IOS Firewall
- IPSec VPN (1.2 Mbps maximum), 8 tunnels

- 4-port 10/100 Mbps switch
- ADSLi WAN port (SOHO 96)
- ADSL WAN port (SOHO 97)
- Cisco IOS Firewall
- IPSec VPN (1.2 Mbps maximum), 8 tunnels

Note:

ADSLi = ADSL over ISDN
ADSL = ADSL over POTS

- 4-port 10/100 Mbps switch
- Ethernet WAN port
- Cisco IOS Firewall, DMZ, 802.1X
- IDS
- IPSec VPN (7 Mbps maximum), 3DES, AES, 10 tunnels
- QoS, AZR

- 4-port 10/100 Mbps switch
- ADSLi WAN port (836)
- ADSL WAN port (837)
- Cisco IOS Firewall, DMZ, 802.1X
- IDS
- IPSec VPN (7 Mbps maximum), 3DES, AES, 10 tunnels
- QoS, AZR
- Optional ISDN backup on 836 only

SMALL BUSINESS/BRANCH

YES

**FIXED CONFIGURATION/
LOW COST/NO VOICE?**

NO

**MODULAR HIGH
PERFORMANCE**

**DO YOU HAVE A
BROADBAND MODEM?**

NO

YES

**CISCO 1701 ADSL
SECURITY
ACCESS ROUTER**

**CISCO 1711/1712
SECURITY
ACCESS ROUTER**

**CISCO 1841
INTEGRATED
SERVICES ROUTER**

**CISCO 2801
INTEGRATED
SERVICES ROUTER**

**CISCO 2811
INTEGRATED
SERVICES ROUTER**



- 1-port 10/100 Mbps
- ADSL WAN port
- Cisco IOS Firewall
- Cisco IOS IPS
- IPsec VPN
- Advanced QoS
- 802.1Q, 802.1X

- 4-port 10/100 Mbps
- Ethernet WAN port
- Cisco IOS Firewall
- Cisco IOS IPS
- IPsec VPN
- Advanced QoS
- Standard ISDN or analogue backup
- 802.1Q, 802.1X

- 2-port Fast Ethernet
- 2 HWIC/VWIC/WICs
- Advanced integration module
- Cisco IOS Firewall
- Cisco IOS IPS
- IPsec VPN
- Advanced QoS
- 802.1Q, 802.1X

- 2-port Fast Ethernet
- 2 HWIC/VWIC/WICs
- 1 VWIC/WIC/VIC
- 1 VWIC/VIC (voice only)
- 2 advanced integration modules
- Cisco IOS Firewall
- Cisco IOS IPS
- IPsec VPN
- Advanced QoS
- 802.1Q, 802.1X
- 2 onboard DSPs

- 2-port Fast Ethernet
- 4 HWICs
- 2 advanced integration modules
- Cisco IOS Firewall
- Cisco IOS IPS
- IPsec VPN
- Advanced QoS
- 802.1Q, 802.1X
- 2 onboard DSPs
- 1-port Network Modul Extended (NME)

NO

**DO YOU NEED
VOICE SERVICES?**

YES

NO

**MORE THAN
24 USERS?**

YES

CISCO ROUTERS – LEGACY NETWORKING

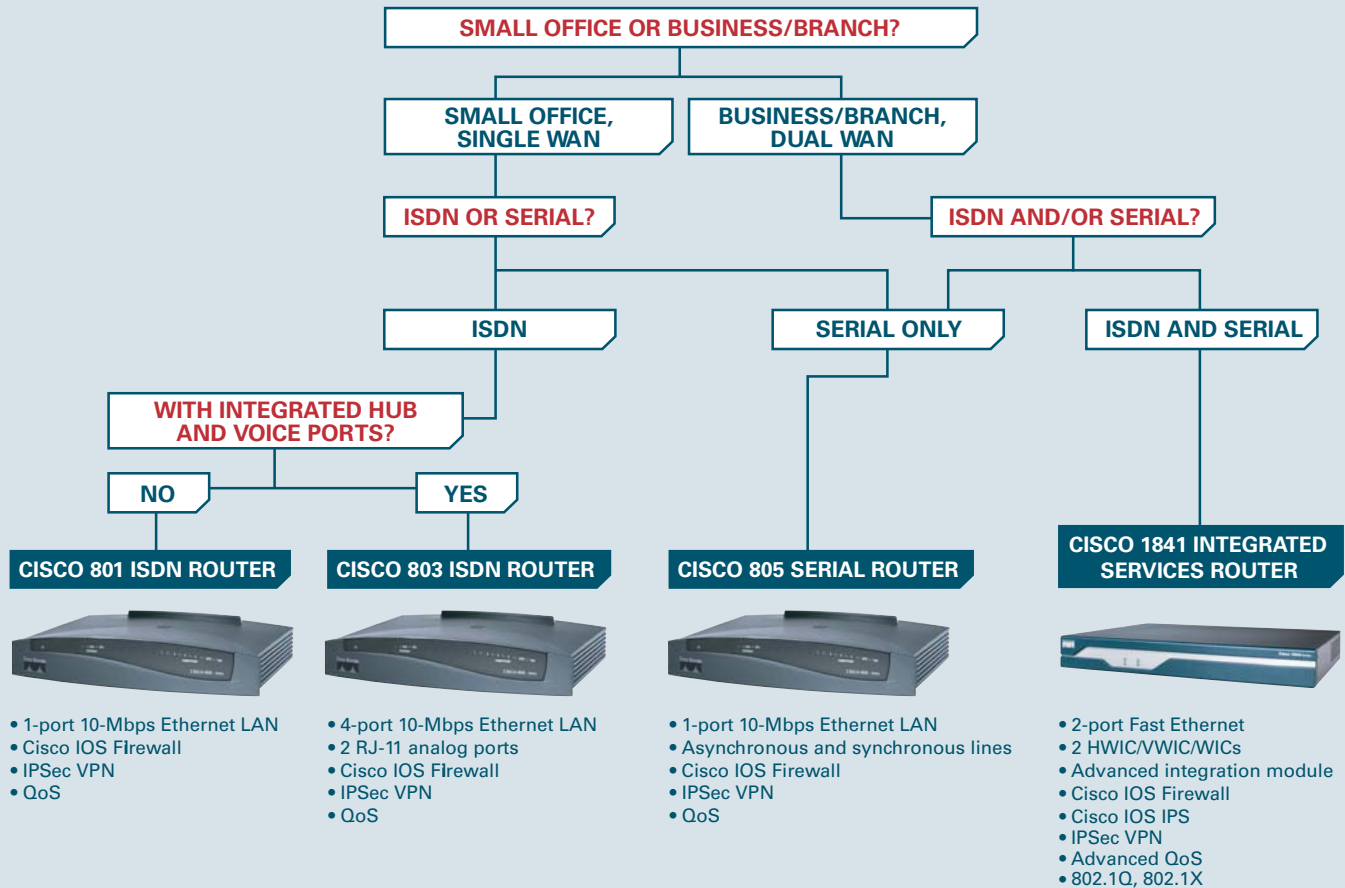

CISCO PIX SECURITY APPLIANCES

HOW MANY EMPLOYEES?

10

CISCO PIX 501



Cisco PIX® 501 Firewall
(10 users with 3DES)
PIX-501-BUN-K9

- Stateful inspection firewall (10 Mbps clear-text throughput)
- 56-bit DES IPsec VPN (6 Mbps throughput)
- 168-bit 3DES IPsec VPN (3 Mbps throughput)
- 128-bit AES IPsec VPN (4.5 Mbps throughput)
- 10 simultaneous remote-access/site-to-site VPN peers
- Intrusion detection
- 4-port 10/100 switch
- Plug and play, Auto Update and Easy VPN
- Free VPN client

50

CISCO PIX 501



Cisco PIX® 501 Firewall
(50 users with 3DES)
PIX-501-50-BUN-K9

- Stateful inspection firewall (10 Mbps clear-text throughput)
- 56-bit DES IPsec VPN (6 Mbps throughput)
- 168-bit 3DES IPsec VPN (3 Mbps throughput)
- 128-bit AES IPsec VPN (4.5 Mbps throughput)
- 10 simultaneous remote-access/site-to-site VPN peers
- Intrusion detection
- 4-port 10/100 switch
- Plug and play, Auto Update and Easy VPN
- Free VPN client

100

CISCO PIX 506E



Cisco PIX® 506E Firewall
(250+ users with 3DES)
PIX-506E-BUN-K9

- Stateful inspection firewall (100 Mbps clear-text throughput)
- 56-bit DES IPsec VPN (20 Mbps throughput)
- 168-bit 3DES IPsec VPN (17 Mbps throughput)
- 128-bit AES IPsec VPN (30 Mbps throughput)
- 25 simultaneous remote-access/site-to-site VPN peers
- Intrusion detection
- 2 10/100 ports
- Plug and play, Auto Update and Easy VPN
- Free VPN client

250+

CISCO PIX 515E



Cisco PIX® 515E Firewall
(250+ users with 3DES)
PIX-515E-R-DMZ-BUN

- Stateful inspection firewall (188 Mbps clear-text throughput)
- 56-bit DES IPsec VPN (20 Mbps throughput)
- 168-bit 3DES IPsec VPN (22-63 Mbps throughput)
- 250 simultaneous remote-access/site-to-site peers
- Intrusion detection
- 3 10/100 ports
- DMZ feature allows users on the Internet to access a Web server while keeping the company network secure.
- Plug and play, Auto Update and Easy VPN
- Free VPN client

Cisco PIX® 515E Firewall
PIX-515E-UR-BUN

- As above
- VPN accelerator card provides
- 168-bit 3DES IPsec VPN (140 Mbps throughput)
- 128-bit AES IPsec VPN (135 Mbps throughput)
- 2000 simultaneous remote-access/site-to-site peers

Cisco PIX Device Manager

- Intuitive, Web-based interface for securely managing a single remote Cisco PIX Security Appliance
- Web-based real-time monitoring monitoring of CPU/memory utilization, interface throughput, connections, and VPN tunnels.
- Full-featured wizards for initial firewall and VPN configuration
- More than 100 predefined services for simplified security policy creation



CISCO IP COMMUNICATIONS SOLUTIONS

HOW MANY HANDSETS ARE REQUIRED?

23

**CISCO
2801-CCME/K9**



- Cisco 2801 CallManager Express bundle
- 1-port RJ-48 multiflex trunk E1
- Cisco Catalyst 3560 24/48-port 10/100 switch
- Cisco IP Phone 7905G

45

**CISCO
2821-CCME/K9**



- Cisco 2821 CallManager Express Bundle
- 1-port RJ-48 multiflex trunk E1
- Cisco Catalyst Switch 3560 24/48-port 10/100 switch
- Cisco IP Phone 7912G
- NM-CUE (includes 12 mailboxes)
- SCUE-LIC-50CME (additional 50 mailboxes)

67

**CISCO
2851-CCME/K9**



- Cisco 2851 CallManager Express Bundle
- 1-port RJ-48 multiflex trunk E1
- Cisco Catalyst Switch 3560 24/48-port 10/100 switch
- Cisco IP Phone 7905G
- NM-CUE (includes 12 mailboxes)
- SCUE-LIC-100CME (additional 100 mailboxes)

89

CISCO
2851-CCME/K9



- Cisco 2851 CallManager Express Bundle
- 1-port RJ-48 multiflex trunk E1
- Cisco Catalyst Switch 3560 24/48-port 10/100 switch
- Cisco IP Phone 7912G
- NM-CUE (includes 12 mailboxes)
- SCUE-LIC-100CME (additional 100 mailboxes)

New Cisco CallManager Express 3.2 Features Available with Cisco IOS Release 12.3(11)T

- Support for 240 IP phones
- Transcoding
- Soft-key customization
- Loopback DN Free
- CUE H.323 to SIP hairpin
- SCCP to RCFC 2833 DTMF support
- Direct FXO line select
- DND divert call to voicemail
- Call waiting beep suppression
- Overlay DN called name display
- Longest idle hunt group with call statistics
- Conference initiator drop-off

Features from Cisco CallManager Express 3.1.1 Maintenance Release

- Japanese Katakana (1-byte) localization
- Cisco IP Phone 7936 support
- H.323 integration with Cisco CallManager 4.0

Features from Cisco CallManager Express 3.2.1 with Cisco IOS Software Release 12.3(11)XL (released November 14)

- Basic ACD (3 queues) with call statistics
- Cisco IP Color Phone 7970 (Cisco CallManager Express & SRST)
- Call waiting with overlay DN
- Call waiting ring
- Feature ring with DND set

Selecting WAN & Voice Modules

- VIC-2E/M—2-port E&M VIC
- VIC-2FXS—2-port analog FXS VIC
- VIC-2FXO—2-port analog FXO VIC
- VIC-2FXO-EU—2-port analog FXO VIC (for Europe)
- VIC-2BRI-NT/TE—2-port BRI VIC (NT and TE)
- VIC-2BRI-S/T-TE—2-port BRI VIC (terminal)
- VVIC-1MFT-E1—1-port E1/PRI VVIC
- VVIC-2MFT-E1—2-port E1/PRI VVIC
- VIC2-2FXS—2-port VIC (FXS)
- VIC2-2FXO—2-port VIC (FXO: universal)
- VIC2-4FXO—4-port VIC (FXO: universal)
- VIC2-2E/M—2-port E&M VIC
- VIC2-2BRI-NT/TE—2-port BRI VIC (NT and TE)
- 1-slot IP Communications voice/fax network module (up to 4 channels of analog/BRI voice)
- 2-slot IP Communications voice/fax network module (up to 8 channels of analog/BRI voice)
- 2-slot IP Communications enhanced voice/fax network module (up to 24 channels of analog/BRI voice)

CISCO IP PHONES

BASIC FEATURES

ADVANCED FEATURES

CISCO IP PHONE 7902G

CISCO IP PHONE 7905G

CISCO IP PHONE 7912G

CISCO IP PHONE 7940G

CISCO IP PHONE 7960



- Entry-level phone
- Single line
- No display
- No configurable fixed keys

- Pixel-based display
- Single line
- Four dynamic soft keys
- Listening mode support
- Supports text-only XML

- Pixel-based display
- Single line
- Four dynamic soft keys
- Listening mode support
- Dual-port integrated Ethernet switch
- Supports text-only XML

- Ideal for desktop office use
- B/W graphic display with two fixed lines of characters
- Four dynamic soft keys
- Four configurable keys
- Integrated external headset socket
- Full-duplex speakerphone
- Integrated dual Ethernet switch port

- Ideal for desktop office use
- B/W graphic display with two fixed lines of characters
- Four dynamic soft keys
- Six configurable keys
- Integrated external headset socket
- Full-duplex speakerphone
- Integrated dual Ethernet switch port

ANALOGUE/FAX

CISCO IP PHONE 7970G



- 8 programmable keys
- 320x234 pixel touch screen display
- 5 soft keys
- Advanced XML support
- IEEE 802.3af inline power support
- Can connect external microphone and speakers

CISCO IP PHONE 7920



- Wireless IP phone
- 802.11b standard
- B/W pixel-based display
- Two soft keys
- XML script support
- A range of 15–300m according to environmental conditions
- Supported on Cisco 340, 350, 1100, and 1200 series access points

CISCO IP CONFERENCE STATION 7935/7936



- Equipped with three microphones for better space coverage
- Full-duplex speakerphone
- Three dynamic soft keys
- Supports three external directional microphones

CISCO IP EXPANSION MODULE 7914



- Attendant console station to be used in conjunction with the Cisco IP Phone 7960 Phone
- Up to 34 extensions can be monitored

CISCO ATA 186/188



- Device with two analog ports to connect faxes or analog phones
- 1 RJ-45 10BASE-T Ethernet port (Cisco 186 ATA)
- 2 Ethernet RJ-45 10/100BASE-T ports (Cisco ATA 188)

CISCO AIRONET FAMILY

CISCO AIRONET WIRELESS LAN SOLUTIONS

- Inline PoE or local power
- Cisco IOS feature set for QoS, security, and VLAN
- Lockable mounting brackets
- Secure with cable/padlock
- 802.11g backward-compatible with 802.11b
- Part of the Cisco SWAN framework

SMB BRANCH OFFICES

CISCO AIRONET 1100 SERIES

Cisco Aironet 1100® Series 802.11g Access Point

AIR-AP1121G-E-K9

- 802.11g: 54 Mbps/2.4 GHz
- Integrated 2-dBi gain omni antenna
- Flexible mounting (wall, ceiling, cubicle, desktop)



ENTERPRISE PUBLIC HOTSPOTS

CISCO AIRONET 1200 SERIES

Cisco Aironet 1200® Series Access Point

- Supports simultaneous dual-band
- Flexible mounting (wall, ceiling)
- Plenum-rated rugged design

AIR-AP1231G-E-K9

- 802.11g: 54 Mbps/2.4 GHz
- 2 RP-TNC connectors for flexible antenna selection

AIR-AP1230A-A-K9

- 802.11a: 54 Mbps/5 GHz
- Integrated dual omni/patch antenna (802.11a only)

CISCO AIRONET WIRELESS BRIDGING SOLUTIONS

- Configurable for access point, bridge, or workgroup bridge roles
- Support for both point-to-point or point-to-multipoint configurations
- Industry-leading range and throughput, supporting data rates of up to 54 Mbps
- Part of the Cisco SWAN framework
- Enhanced security mechanisms based on 802.1X standards
- Ruggedized enclosure optimized for harsh outdoor environments with extended operating temperature range
- Integrated or optional external antennas for flexibility in deployment

CISCO AIRONET 1300 SERIES

Cisco Aironet 1300® Series Outdoor Access Point/Bridge

802.11g radio: 54 Mbps

AIR-BR1310G-E-K9

Integrated 13-dBi antenna

AIR-BR1310G-E-K9-R

RP-TNC connectors for flexible antenna selection



Typical Example



Cisco Aironet Series 1200 802.11g Access Point

AIR-AP1231G-E-K9

- 802.11g: 54 Mbps/2.4 GHz



Cisco Aironet Series 1200 802.11a radio module

AIR-RM20A-A-K9

- 802.11a: 54 Mbps/5 GHz



Simultaneous dual-band operation 802.11a+g

GLOSSARY

100BASE-FX – 100-Mbps fixed uplink configuration

1000BASE-T – The Gigabit Ethernet standard (1 gigabit is 1000 megabits per second) using four pairs of Category 5 (CAT-5) and above Unshielded Twisted Pair (UTP) copper cables.

Advanced Encryption Standard (AES) – A new encryption algorithm that is set to replace the DES algorithm. It uses a secret key of variable length (128 to 256 bits) to provide symmetric encryption for data in the IP Security (IPSec) suite of protocols.

Asymmetric Digital Subscriber Line (ADSL) – A technology for transmitting digital information at high bandwidth on existing phone lines to homes and businesses. Provides a continuously available, “always on” connection.

Bridge – Connects one LAN to another using the same protocol.

Cisco IOS Software – The standard operating system used by all Cisco internetworking solutions. It provides a solution that is secure, highly resilient, easy to manage, scalable, and flexible, enabling new technologies to be deployed quickly and without heavy reinvestment. Cisco IOS Software is the most widely used internetworking operating system, providing further assurance of interoperation and reliability

Data Encryption Standard (DES) – A widely used encryption algorithm that has been used as a default for the last 20 years. There are two principle key lengths, 56-bit for DES and 168-bit for Triple DES (3DES). DES is accepted as being unbreakable except by brute force (trying every key permutation), and is part of the suite of IPSec protocols.

Demilitarised zone (DMZ) – A computer host or small network inserted as a “neutral zone” between a company’s private network and the outside public network. A DMZ prevents direct access to servers storing company data and provides greater security than a firewall.

Ethernet – The most widely installed LAN technology. The most common Ethernet systems are 10BASE-T, providing transmission speeds of up to 10 Mbps.

Firewall – A security system designed to protect a network against external threats, such as hackers.

Gigabit – A transfer rate of 1000 Mbps.

Gigabit interface converter (GBIC) – An optical or copper transceiver for flexible connections, up to and including gigabit speed, over different types of media.

IEEE – The Institute of Electrical and Electronics Engineers, notable for developing national and international standards.

IEEE 802.11 – The formal standard for the wireless networking protocol.

Integrated Services Digital Network (ISDN) – A set of standards for digital transmission over ordinary telephone copper wire and other media.

Intranet – A private network created within a business or organization.

Intrusion detection system (IDS) – A security countermeasure that monitors data traffic and events, looking for signs of intruders.

GLOSSARY (CONTINUED)

IP Security (IPSec) – A suite of protocols that provides authentication, integrity, and encryption algorithms.

LAN – A group of computers and associated devices sharing a common communications line or wireless link and typically sharing the resources of a single processor or server within a small geographic area (within an office building, for example).

Megabits per second (Mbps) – Data transfer speed measured in multiples of 1 million bits per second.

Modular (chassis) switch – An upgradable switch with flexible capabilities.

Quality of service (QoS) – For optimum efficiency, the QoS component of Cisco IOS Software enables networks to control and provide predictable service to numerous applications, allocating priority, dedicating bandwidth, and controlling jitter and latency.

Router – A device that moves data between different network segments and can look into a packet header to determine the best path for the packet to travel. Routers can connect network segments that use different protocols. They also allow all users in a network to share a single connection to the Internet or WAN.

Small Form Factor Pluggable (SFP) – A flexible port on Cisco Catalyst switches that can be configured with different types of copper or Fibre uplinks (sold separately).

Stackable switch – A switch that can stack several physical units together to make a single logical entity.

Switch – A device that improves network performance by segmenting the network. When a switch port receives data packets, it forwards those packets only to the appropriate port for the intended recipient. This capability further reduces competition for bandwidth between the clients, servers, or workgroups connected to each switch port.

Uplinks

- High-speed link to the backbone, server, or router.
- Copper uplinks are based on CAT-5 cabling and above, and can be used for distances of up to 100 meters.
- Fiber-optic uplinks are used for greater distances, or where copper is not practical.

VPN – A secure tunnel across the Internet through which data, video, and voice traffic can be transmitted.

WAN – A network that connects devices over great distances, such as geographical regions. A WAN often connects two or more LANs. See also LAN.

LINKS

Product Links

Cisco Catalyst 2950 Series Switches

www.cisco.com/go/catalyst2950

Cisco Catalyst 3550 Series Switches

www.cisco.com/go/catalyst3550

Cisco Catalyst 3750 Series Switches

www.cisco.com/go/catalyst3750

Cisco Catalyst 2940 Series Switches

www.cisco.com/go/catalyst2940

Cisco Catalyst 3560 Series Switches

www.cisco.com/go/catalyst3560

Cisco Routers

www.cisco.com/go/routers

Cisco Security Solutions

www.cisco.com/go/security

Cisco Wireless Networking Products

www.cisco.com/go/wireless

Cisco IP Communications

www.cisco.com/go/ipc

Sales and Marketing Tools

Cisco SMB Engage Portal

www.cisco.com/go/smbengage



Corporate Headquarters
Cisco Systems, Inc.
170 West Tasman Drive
San Jose, CA 95134-1706
USA
www.cisco.com

Tel: +1 408 526 4000
+1 800 553 NETS (6387)
Fax: +1 408 526 4100

European Headquarters
Cisco Systems International BV
Haarlerbergpark
Haarlerbergweg 13-19
1101 CH Amsterdam
The Netherlands
www-europe.cisco.com

Tel: +31 0 20 357 1000
Fax: +31 0 20 357 1100

Americas Headquarters
Cisco Systems, Inc.
170 West Tasman Drive
San Jose, CA 95134-1706
USA
www.cisco.com

Tel: 408 526-7660
Fax: 408 527-0883

Asia Pacific Headquarters
Cisco Systems, Inc.
Capital Tower
168 Robinson Road
#28-01 Capital Tower
Singapore 068912
www.cisco.com

Tel: +65 6317 7777
Fax: +65 6317 7799

Cisco Systems has more than 200 offices in the following countries and regions. Addresses, phone numbers, and fax numbers are listed on the **Cisco.com Web site at www.cisco.com/go/offices.**

Argentina • Australia • Austria • Belgium • Brazil • Bulgaria • Canada • Chile • China PRC • Colombia • Costa Rica • Croatia • Cyprus • Czech Republic
Denmark • Dubai, UAE • Finland • France • Germany • Greece • Hong Kong SAR • Hungary • India • Indonesia • Ireland • Israel • Italy
Japan • Korea • Luxembourg • Malaysia • Mexico • The Netherlands • New Zealand • Norway • Peru • Philippines • Poland • Portugal
Puerto Rico • Romania • Russia • Saudi Arabia • Scotland • Singapore • Slovakia • Slovenia • South Africa • Spain • Sweden
Switzerland • Taiwan • Thailand • Turkey • Ukraine • United Kingdom • United States • Venezuela • Vietnam • Zimbabwe

Copyright © 2005 Cisco Systems, Inc. All rights reserved. CCIP, CCSP, the Cisco Arrow logo, the Cisco *Powered* Network mark, Cisco Unity, Follow Me Browsing, FormShare, and StackWise are trademarks of Cisco Systems, Inc.; Changing the Way We Work, Live, Play, and Learn, and iQuick Study are service marks of Cisco Systems, Inc.; and Aironet, ASIST, BPX, Catalyst, CCDA, CCDP, CCIE, CCNA, CCNP, Cisco, the Cisco Certified Internetwork Expert logo, Cisco IOS, the Cisco IOS logo, Cisco Press, Cisco Systems, Cisco Systems Capital, the Cisco Systems logo, Empowering the Internet Generation, Enterprise/Solver, EtherChannel, EtherSwitch, Fast Step, GigaStack, Internet Quotient, IOS, IP/TV, iQ Expertise, the iQ logo, iQ Net Readiness Scorecard, LightStream, Linksys, MGX, MICA, the Networkers logo, Networking Academy, Network Registrar, Packet, PIX, Post-Routing, Pre-Routing, RateMUX, Registrar, ScriptShare, ScriptShare, SlideCast, SMARTnet, StrataView Plus, Stratm, SwitchProbe, TeleRouter, The Fastest Way to Increase Your Internet Quotient, TransPath, and VCO are registered trademarks of Cisco Systems, Inc. and/or its affiliates in the United States and certain other countries.

All other trademarks mentioned in this document or Website are the property of their respective owners. The use of the word partner does not imply a partnership relationship between Cisco and any other company. (0301R)
AVVIO V.3 – 02.05