



Cisco Catalyst 6500 Series Content Switching Module



The Cisco Content Switching Module (CSM) is a Cisco Catalyst[®] 6500 line card that balances client traffic to farms of servers, firewalls, Secure Sockets Layer (SSL) devices, or virtual private network (VPN) termination devices. The Cisco CSM provides a high-performance, cost-effective load-balancing solution for enterprise and Internet service provider (ISP) networks. The Cisco CSM meets the demands of high-speed content delivery networks, tracking network sessions and server load conditions in real time and directing each session to the most appropriate server. Fault-tolerant Cisco CSM configurations maintain full state information and provide true hitless failover required for mission-critical functions.

The Cisco CSM provides the following key benefits (refer to Figure 1):

- Market-leading performance—The Cisco CSM establishes up to 165,000 Layer 4 connections per second (depending on software version) and provides high-speed content switching while maintaining 1 million concurrent connections.
- Outstanding price/performance value for large data centers and ISPs—The Cisco CSM features a low connection cost and occupies a small footprint. It slides into a slot in a new or existing Cisco Catalyst 6500 and enables all ports in the Cisco Catalyst 6500 for Layer 4–7 content switching.
- Multiple Cisco CSMs can be installed in the same Cisco Catalyst 6500.
- Ease of configuration—The Cisco CSM uses the same Cisco IOS[®] command-line interface (CLI) that is used to configure the Cisco Catalyst 6500 Switch.

Figure 1. The Cisco CSM

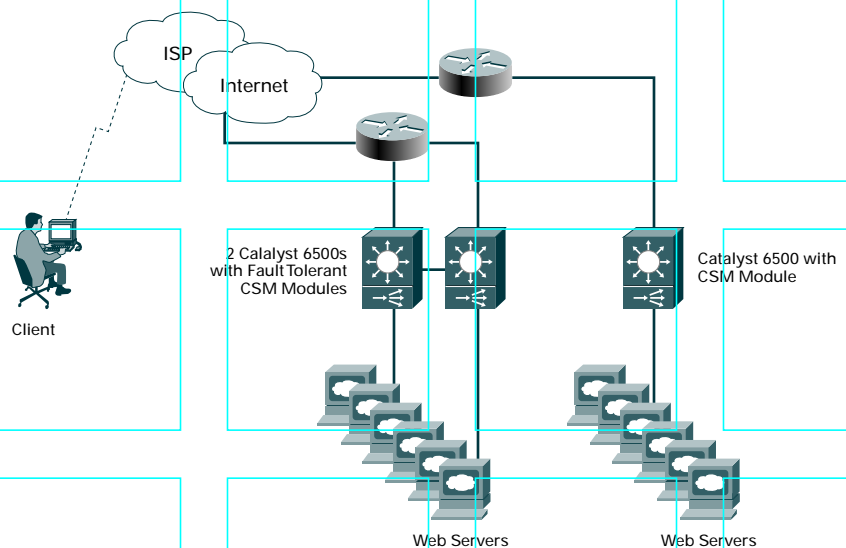

Content Switching Module Key Features

Firewall Load Balancing

The Cisco CSM allows you to scale firewall protection by distributing traffic across multiple firewalls on a per-connection basis, while ensuring that all packets belonging to a particular connection go through the same firewall. Both stealth and regular firewalls are supported.

URL and Cookie-Based Load Balancing

The Cisco CSM allows full regular expression pattern matching for policies based on URLs, cookies, and Hypertext Transfer Protocol (HTTP) header fields. The Cisco CSM supports any URL or cookie format—allowing it to load balance existing Web content without requiring URL/cookie format changes.

High Performance

The Cisco CSM performs up to 165,000 new Layer 4 TCP connection setups per second, depending on software version. These connections can be spread across 4096 virtual servers (16,384 real servers) and all the ports in a Cisco Catalyst 6500, or they can be focused on a single port. This provides a benefit over competitors who use distributed architectures that require use of all the ports in order to gain maximum performance.

Network Configurations

The Cisco CSM supports many different network topology types. A Cisco CSM can operate in a mixed bridged and routed configuration, allowing traffic to flow from the client side to the server side on the same or on different IP subnets.

IP Protocol Support

The Cisco CSM accommodates a wide range of common IP protocols—including TCP and User Datagram Protocol (UDP). Additionally, the Cisco CSM supports higher-level protocols, including HTTP, File Transfer Protocol (FTP), Telnet, Real-Time Streaming Protocol (RTSP), Domain Name System (DNS), and Simple Mail Transfer Protocol (SMTP).

User Session Stickiness

Whenever encryption or e-commerce is involved, it is important that the end user is consistently directed to the same server—that is, the server where the user's shopping cart is located or the encryption tunnel terminates. Cisco CSM User Session Stickiness provides the ability to consistently bring users back to the same server-based on SSL session ID, IP address, cookie, or HTTP redirection.

Load-Balancing Algorithms

The Cisco CSM supports the following load-balancing algorithms:

- Round robin
- Weighted Round Robin
- Least connections
- Weighted least connections
- Source and/or destination IP hash (subnet mask also configurable)
- URL hashing

Quality of Service

Providing differentiated levels of service to end users is important when generating revenue from content. The Cisco CSM takes advantage of the robust quality of service (QoS) of the Cisco Catalyst 6500, enabling traffic differentiation as follows:

- Correctly prioritizes packets based on Layer 7 rules
- Directs users who are paying more for services to faster or less loaded servers

High Availability

The Cisco CSM continually monitors server and application availability using health monitoring probes, inband health monitoring, return code checking, and the Dynamic Feedback Protocol (DFP). When a real server or gateway failure occurs, the Cisco CSM redirects traffic to a different location. Servers can be added and removed without disrupting service—systems can easily be scaled up or down.

Connection Redundancy

Optionally, two Cisco CSMs can be configured in a fault-tolerant configuration to share state information about user sessions and provide connection redundancy. If the active Cisco CSM fails, open connections are handled by the standby CSM without interruption, and users experience hitless failover—an important requirement for e-commerce sites and sites where encryption is used.

Global Server Load Balancing

The CSM offers multiple options for building a global or geographical load balanced environment. The CSM can act as an authoritative DNS and perform GSLB among geographically dispersed CSMs for the purposes of disaster recovery or for small GSLB environments with 2-4 locations. In addition, the CSM can report load information for its Virtual IPs into the Global Site Selector (GSS), an appliance designed for advanced GSLB scaling up to 128 sites. With the many different GSLB options the CSM offers the ability to scale GSLB capabilities as growth demands.

Configuration Limits

- Total virtual LANs (VLANs) (client and server): 256
- Virtual servers: 4000
- Server farms: 4000

- Real servers: 16,000
- Probes: 4000
- Access control list (ACL) items: 16,000

Performance Summary	
Connections	
1,000,000 concurrent TCP connections	
165,000 connection setups per second—Layer 4	
Throughput	
Total combined throughput of 4 Gigabits per second (client to server and server to client)	
Cisco Catalyst Switch Platform Requirements	
Cisco IOS Software only—Cisco Catalyst Operating System is not supported	
Not fabric enabled—Functions as a bus-enabled line card	
Multilayer Switch Feature Card (MSFC) or MSFC2	
Physical Specifications	
Occupies slot in the Cisco Catalyst 6500 chassis	
Dimensions (H x W x D): 1.2 x 14.4 x 16 in. (3.0 x 35.6 x 40.6 cm)	
Weight: 5 lb (2.27 kg)	
Operating Environment	
Operating temperature: 32 to 104.5°F (0 to 40°C)	
Nonoperating temperature: -40 to 158°F (-40 to 70°C)	
Operating relative humidity: 10 to 90% (noncondensing)	
Nonoperating relative humidity: 5 to 95% (noncondensing)	
Operating and nonoperating altitude: Sea level to 10,000 ft (3050m)	
Agency Approvals	
Emissions: FCC Part 15 (CFR 47) Class A, ICES-003 Class A, EN55022 Class A, CISPR22 Class A, AS NZS 3548 Class A	
Safety: CE Marking according to UL 1950, CSA 22.2 No. 950, EN 60950, IEC 60950, TS 001, AS/NZS 3260	

Cisco Catalyst 6500 CSM Ordering Information

Product Number	Product Description
WS-X6066-SLB-APC	Cisco Catalyst 6500 Content Switching Module

CISCO SYSTEMS



Corporate Headquarters
Cisco Systems, Inc.
170 West Tasman Drive
San Jose, CA 95134-1706
USA
www.cisco.com
Tel: 408 526-4000
800 553-NETS (6387)
Fax: 408 526-4100

European Headquarters
Cisco Systems Europe
11, Rue Camille Desmoulins
92782 Issy-les-Moulineaux
Cedex 9
France
www-europe.cisco.com
Tel: 33 1 58 04 60 00
Fax: 33 1 58 04 61 00

Americas Headquarters
Cisco Systems, Inc.
170 West Tasman Drive
San Jose, CA 95134-1706
USA
www.cisco.com
Tel: 408 526-7660
Fax: 408 527-0883

Asia Pacific Headquarters
Cisco Systems, Inc.
Capital Tower
168 Robinson Road
#22-01 to #29-01
Singapore 068912
www.cisco.com
Tel: 65 317 7777
Fax: 65 317 7799

Cisco Systems has more than 200 offices in the following countries and regions. Addresses, phone numbers, and fax numbers are listed on the
Cisco Web site at www.cisco.com/go/offices

Argentina • Australia • Austria • Belgium • Brazil • Bulgaria • Canada • Chile • China PRC • Colombia • Costa Rica • Croatia
Czech Republic • Denmark • Dubai, UAE • Finland • France • Germany • Greece • Hong Kong SAR • Hungary • India • Indonesia • Ireland
Israel • Italy • Japan • Korea • Luxembourg • Malaysia • Mexico • The Netherlands • New Zealand • Norway • Peru • Philippines • Poland
Portugal • Puerto Rico • Romania • Russia • Saudi Arabia • Scotland • Singapore • Slovakia • Slovenia • South Africa • Spain • Sweden
Switzerland • Taiwan • Thailand • Turkey • Ukraine • United Kingdom • United States • Venezuela • Vietnam • Zimbabwe

Copyright © 2002, Cisco Systems, Inc. All rights reserved. Catalyst, Cisco, Cisco IOS, Cisco Systems, and the Cisco Systems logo are registered trademarks or trademarks of Cisco Systems, Inc. and/or its affiliates in the U.S. and certain other countries. All other trademarks mentioned in this document or Web site are the property of their respective owners. The use of the word partner does not imply a partnership relationship between Cisco and any other company. (0208R)

Printed in the USA