



Cisco IP RAN Optimization Solution

Optimize RAN Transport with IP to Increase Bandwidth Efficiency and Introduce New IP Services

Mobile operators are examining the capacity and flexibility of their radio access networks (RANs) in order to support and enable the next generation of voice and innovative new data and video services. Today's radio transmission and network planners face the challenge of evolving their RAN architecture to deliver greater capacity and flexibility while simultaneously controlling operational costs. Cisco Systems® is applying its networking leadership to develop scalable solutions that provide increased transport efficiency, flexible network infrastructure, and rich IP service capabilities in the RAN.

“RAN backhaul accounts for over 30 percent of total OpEx”

—Yankee Group, March 2005.

The Cisco IP RAN Optimization Solution

The Cisco® IP RAN Optimization Solution Demonstrates How IP Innovation Delivers Value in the RAN

While mobile operators are actively deploying enhanced voice and data services, new services do not have to mean increased costs for RAN transport. With the Cisco IP RAN Optimization solution, transport of Global System for Mobile Communications (GSM) and Universal Mobile Telecommunications Service (UMTS) traffic is optimized using our world-leading IP technology. Existing GSM backhaul throughput is increased by up to 50 percent. This means operators can avoid adding extra T1/E1 lines and speed up deployments by making better use of existing backhaul network capacity, saving time and money.

Along with reducing RAN transport costs, the Cisco IP RAN Optimization solution extends IP to the cell site to enable new revenue-generating services such as IP camera broadcast and surveillance, Wi-Fi and WiMAX hotspots, and IP telephony.

Applications of Cisco IP RAN Optimization Solution

- GSM/UMTS Backhaul Optimization
- HSDPA Offload
- Cell site IP Services

Reduced OpEx and Increased Efficiency for Backhaul

Cisco IP RAN Optimization delivers IP connectivity for GSM and UMTS RAN transport, and reduces operating expenses (OpEx) for RAN backhaul links by optimizing and aggregating bandwidth for GSM Abis and UTRAN Iub interfaces. GSM traffic is optimized up to 50 percent by removing idle channels and repeating patterns on the time-division multiplexing (TDM) link, so operators can transport the same level of GSM traffic with half the number of T1/E1 links. UMTS traffic is compressed 15 to 90 percent by removing idle cells and unused padding, and multiplexing small payloads into single cells.

This industry-leading solution combines optimized GSM and UMTS voice and data frames into IP packets at the cell site and transports them over the backhaul network. At the central site, the traffic frames are extracted from the IP packets and the Abis or Iub data streams are rebuilt. The result is a transparent, radio vendor-independent solution that does not impact voice quality.

Cisco IP RAN Optimization is transparent end-to-end and does not require any change in the control and software update operations of Base Transceiver Station (BTS) and Base Station Controller (BSC), and Node-B and Radio Network Controller (RNC).

The Cisco IP RAN Optimization solution is good news to mobile operators in regions with expensive leased lines because it more efficiently utilizes existing bandwidth and allows operators to scale with the same transport capacity to support enhanced second-generation (2G) and 3G voice and data services.

Mobile operators with High-Speed Downlink Packet Access (HSDPA) in particular will be able to reduce OpEx by taking advantage of the backhaul independent nature of IP to offload the bandwidth hungry traffic to a Metro Ethernet, cable, WiMAX, or xDSL network as alternative backhaul solutions—gaining broadband capacities at lower costs.

Network Deployment Options

The Cisco IP RAN Optimization solution can be used for leased-line, microwave, and satellite transport optimization for GSM and UMTS systems, and for HSDPA and UMTS data offload over IP broadband networks for UMTS systems.

New IP Services Delivered by Cell-Site Point of Presence

Operators Worldwide are Always Looking for New Services to Attract New Customers

The Cisco IP RAN Optimization solution allows mobile operators to use their cell-site assets and introduce new revenue-generating services for their end users.



Because of their broad distribution, cell sites represent points of presence (POPs) that mobile operators can use to provide additional services to customers in that area. These new IP services include IP cameras for traffic and weather information; Wi-Fi and WiMAX hotspots; and for client companies within a cell-site coverage area, Internet data services, IP private branch exchange (PBX), and IP telephony services. Mobile operators can also use this solution to install Web cameras for monitoring and surveillance, and to support cell-site management.

All These Services can be Run Over the IP Optimized RAN Backhaul Network

All these services can be run over the IP optimized RAN backhaul network, using the excess bandwidth released by the Cisco IP RAN Optimization solution. This solution allows mobile operators to extract new revenue-generating services from the existing network, delivering higher profitability and customer satisfaction.

Benefits of Cisco IP RAN Optimization Solution

The Cisco IP RAN Optimization solution delivers strategic solutions to achieve near-term business goals while creating long-term value.

Its value propositions include the following:

- Reduce RAN transport OpEx for GSM and UMTS networks by optimizing and aggregating multiple generations of radio traffic
- Leverage the existing transport network for future growth to support enhanced 2G (GPRS, EDGE) and 3G (UMTS, HSDPA) voice and data broadband wireless services without adding expensive T1/E1 lines
- Offload bandwidth-hungry traffic such as HSDPA over a broadband IP backhaul network such as Metro Ethernet, Cable, WiMAX, and xDSL to further reduce OpEx, provide higher bandwidth, and increase network flexibility
- Deliver innovative, IP-based services such as IP camera broadcast and surveillance, Wi-Fi and WiMAX hotspots, and IP telephony access at existing GSM and UMTS cell sites to create new revenue streams

**Cisco IP RAN Optimization Solution
Using IP, Network Bandwidth Efficiency Increase and Lowers OpEx**

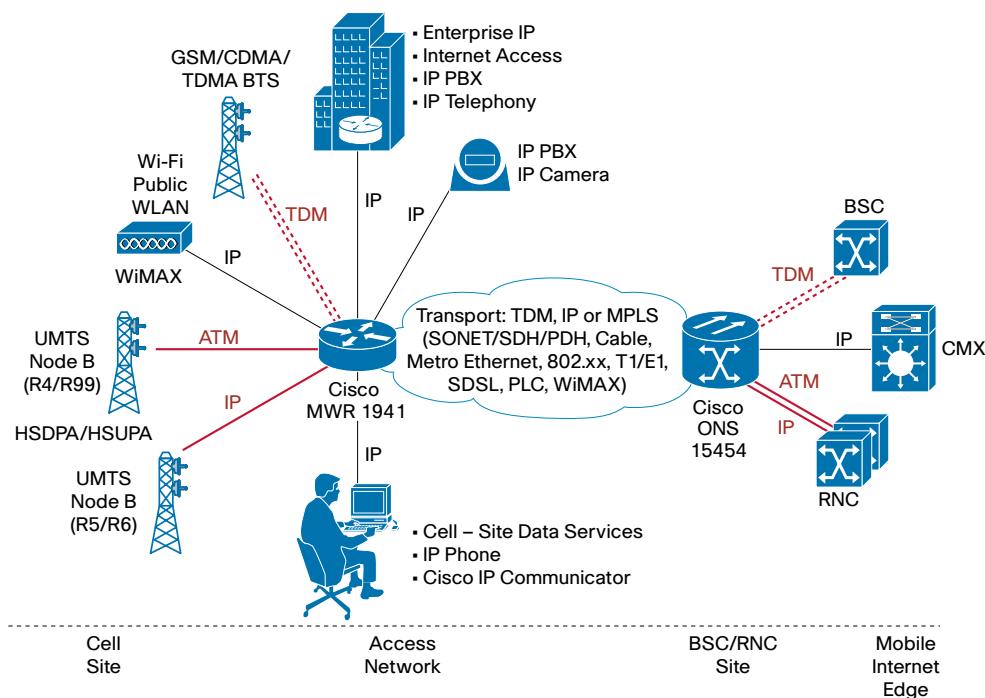



The Cisco IP Next-Generation Network (IP NGN) Vision

Includes the anytime, anywhere availability of voice, data, and video IP applications on digital devices of many kinds. Cisco IP RAN Optimization is an integral part of the Cisco IP NGN strategy and offerings for mobile operators. It extends Cisco IP expertise from the network core to cellular sites with an efficient and flexible IP RAN transport solution that applies a radio vendor-independent technology and integrates easily into an existing RAN.

Why Cisco

As the undisputed IP leader, Cisco Systems provides the technology, solutions, and expertise that mobile operators need as they transition to next-generation networks. Deploying solutions that deliver greater network intelligence, integration, and overall flexibility will not only give operators short-term relief but ultimately boost their competitive advantage.

For More Information

Cisco and Cisco partners can assist you in taking advantage of the many compelling benefits of an IP optimized RAN today. To read more about IP RAN Optimization visit www.cisco.com/go/mobile/ipran.

Learn more about Cisco Systems products and technologies for mobile operators by contacting your account manager or visiting at www.cisco.com/go/mobile.



Americas Headquarters

Cisco Systems, Inc.
170 West Tasman Drive
San Jose, CA 95134-1706
USA
www.cisco.com
Tel: 408 526-4000
800 553-NETS (6387)
Fax: 408 527-0883

Asia Pacific Headquarters

Cisco Systems, Inc.
168 Robinson Road
#28-01 Capital Tower
Singapore 068912
www.cisco.com
Tel: +65 6317 7777
Fax: +65 6317 7799

Europe Headquarters

Cisco Systems International BV
Haarlerbergpark
Haarlerbergweg 13-19
1101 CH Amsterdam
The Netherlands
www-europe.cisco.com
Tel: +31 0 800 020 0791
Fax: +31 0 20 357 1100

Cisco has more than 200 offices worldwide. Addresses, phone numbers, and fax numbers are listed on the Cisco Website at www.cisco.com/go/offices.

©2006 Cisco Systems, Inc. All rights reserved. CCVP, the Cisco logo, and the Cisco Square Bridge logo are trademarks of Cisco Systems, Inc.; Changing the Way We Work, Live, Play, and Learn is a service mark of Cisco Systems, Inc.; and Access Registrar, Aironet, BPX, Catalyst, CCDA, CCDP, CCIE, CCIP, CCNA, CCNP, CCSP, Cisco, the Cisco Certified Internetwork Expert logo, Cisco IOS, Cisco Press, Cisco Systems, Cisco Systems Capital, the Cisco Systems logo, Cisco Unity, Enterprise/Solver, EtherChannel, EtherFast, EtherSwitch, Fast Step, Follow Me Browsing, FormShare, GigaDrive, GigaStack, HomeLink, Internet Quotient, IOS, IP/TV, IQ Expertise, the IQ logo, IQ Net Readiness Scorecard, iQuick Study, LightStream, Linksys, MeetingPlace, MGX, Networking Academy, Network Registrar, Packet, PIX, ProConnect, RateMUX, ScriptShare, SlideCast, SMARTnet, StackWise, The Fastest Way to Increase Your Internet Quotient, and TransPath are registered trademarks of Cisco Systems, Inc. and/or its affiliates in the United States and certain other countries.

All other trademarks mentioned in this document or Website are the property of their respective owners. The use of the word partner does not imply a partnership relationship between Cisco and any other company. (0609R)