

GainMaker 1 GHz High Output 4-Port Node with 65/86 MHz Split

The GainMaker High Output 4-Port Node is designed to serve as an integral part of today's network architectures. The GainMaker High Output 4-Port Node combines the proven technologies of both the GainMaker RF Amplifier and Prisma Optical components. Featuring four high level RF output ports and a segmentable reverse path, it is an ideal platform for delivering video (digital and analog) as well as high-speed data services over advanced hybrid fiber/coax (HFC) networks.

Reverse traffic can be segmented and routed to analog FP, DFB, CWDM, or DWDM. Additionally, the GainMaker High Output 4-Port Node is available with an optional custom status monitoring-HMS transponder for use with all HMS compliant monitoring and control element management systems. On-board temperature, RF switch position (wink switch), power supply condition, as well as other features/parameters can be monitored through this module.

Figure 1. GainMaker High Output 4-Port Node

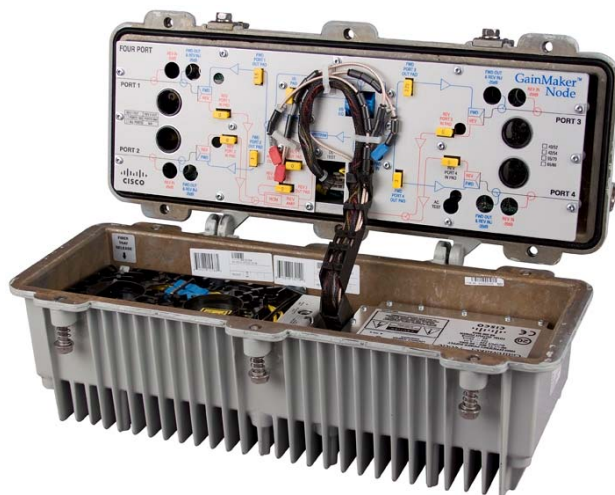

Features

- The GainMaker High Output 4-Port Node uses plug-in accessories common to all GainMaker products
- Two Optical Transmitters and one receiver positions/position in lid
- Optional plug-in Status Monitoring
- Optional reverse redundancy option; two reverse transmitters (one in "hot standby") for the non-segmented node case
- Fiber entry & management tray provides easy access to fiber connections and folds back to provide access to optical transmitter and receivers
- Reverse input pad and RF test point for each reverse port allows optimum reverse path design and alignment

Block Diagrams

Figure 2. Combined Reverse Path with Redundant Transmitter

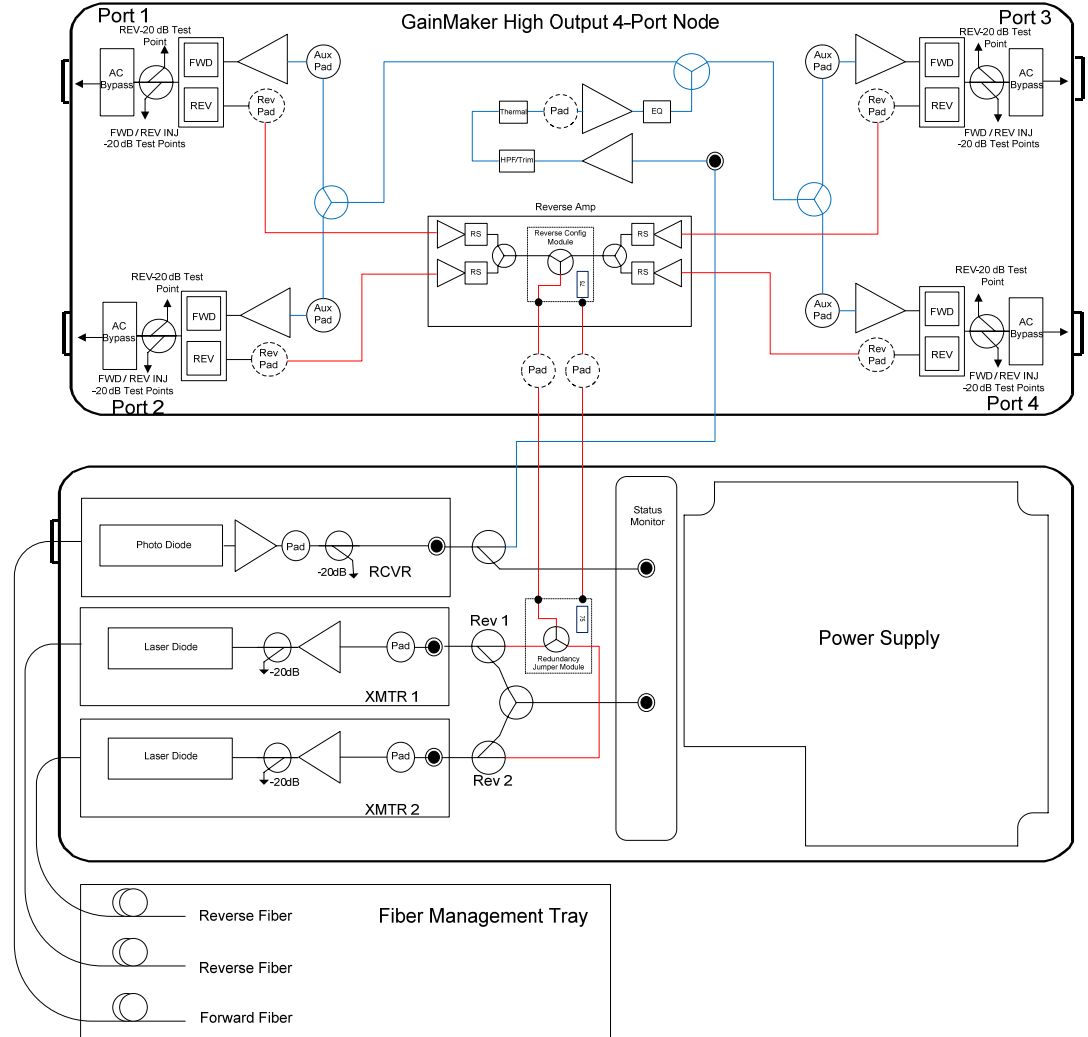

Block Diagrams

Figure 3. Segmented Reverse Path

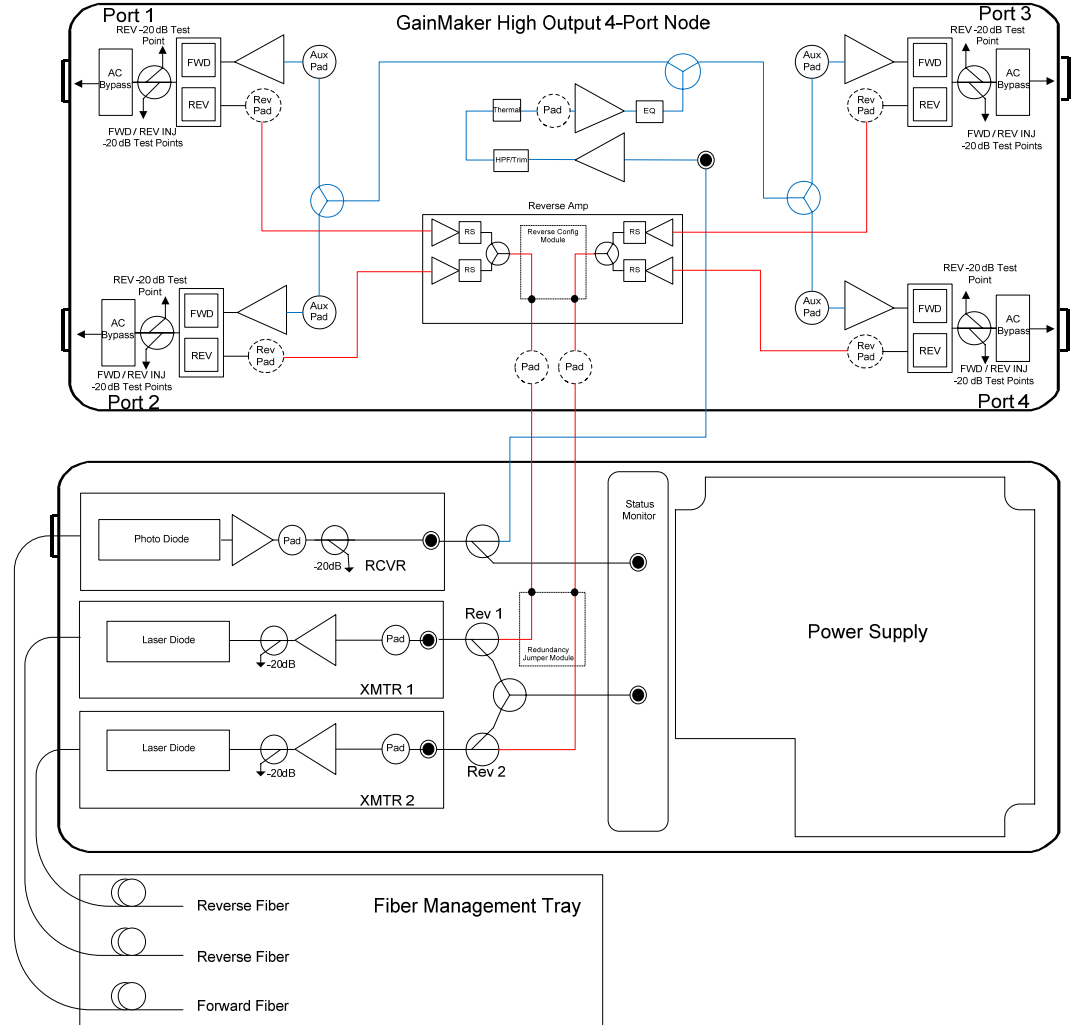

Block Diagrams

Figure 4. Config Module Block Diagrams

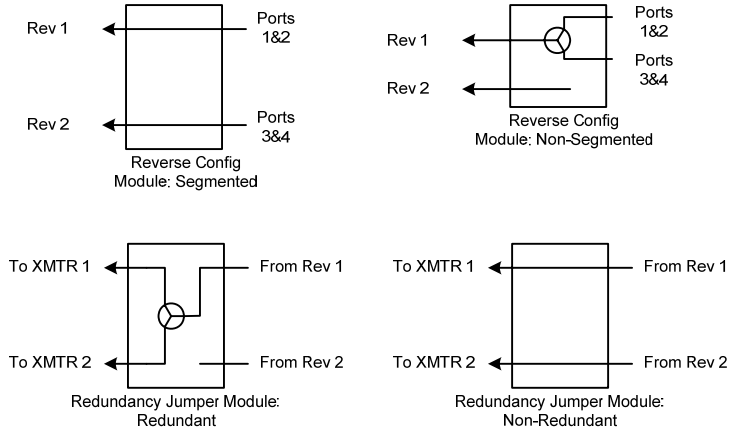

Product Specifications

Table 1. Optical Section

Optical Section - Forward Receiver Module	Units	GainMaker Standard RX	Notes
Wavelength	nm	1310 and 1550	
Optical Input Range	mW dBm	0.5 to 1.6 -3 to +2	
Pass Band	MHz	52-1002	
Frequency Response	dB	0.75	1
Tilt (1.0 dB)	dB	0	
Optical Input Test Point (10%)	V DC	1V/mW	
RF Output Level @ 0 dBm Optical Input	dBmV	Refer to chart (below)	2
RF Output Test Point (± 1.0 dB)	dB	-20	

Receiver RF Output Level Vs Transmitter OMI

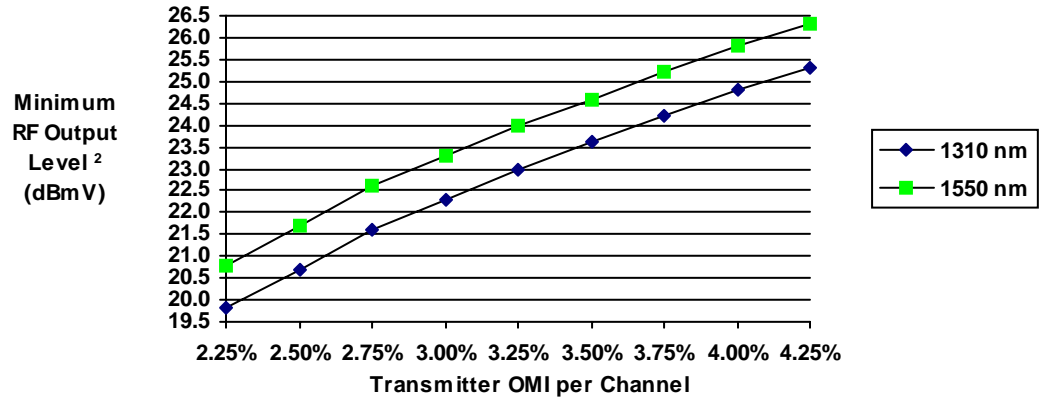

Optical Section Notes:

1. For forward receiver module only. Does not include frequency response contributions from forward optical transmitter.
2. Minimum receiver RF output level for the stated transmitter percent OMI/ch. (Optical Modulation Index per channel), with receiver optical input power of 0 dBm. To determine RF output levels at other optical input power, add (or subtract) 2 dB in RF level for each 1 dB increase (or decrease) in receiver optical input power.

For reverse optical transmitter and link performance, see the “Analog Reverse Optical Transmitters for Model 6940/6944 and GainMaker Optoelectronic Stations” data sheet or the “GS7000 & GainMaker Reverse Segmentable Node bdr Digital Reverse 2:1 Multiplexing System” data sheet.

Product Specifications

Table 2. RF Section Specifications

General Station Performance	Units	Forward	Reverse	Notes
Pass Band	MHz	86-1002	5-65	
Return Loss	dB	16	16	
Hum Modulation @ 12 A	dB	70 (86-870 MHz) 60 (870-1002 MHz)	60 (5-10 MHz) 70 (11-65 MHz)	
Hum Modulation @ 15 A	dB	65 (86-870 MHz) 60 (870-1002 MHz)	60 (5-10 MHz) 65 (11-65 MHz)	
Test Points (± 0.5 dB)	dB	-20	-20	

Table 3. Launch Amplifier Performance - Forward

Launch Amplifier Performance - Forward	Units	HGBT	Notes
Operational Gain (minimum)	dB	41	
Frequency Response	dB	0.5	
Internal Tilt (± 1 dB)	dB	14.0	1,2
Noise Figure @... 86 MHz 1002 MHz	dB	8.5 8.0	
Reference Output Levels @... 1002 MHz 870 MHz 750 MHz 650 MHz 550 MHz 86 MHz	dBmV	56.0 54.0 52.2 50.5 49.0 42.0	
Reference Output Tilt (86-1002 MHz)	dB	14.0	1,3
64 PAL B/G channels (CW) with digital			8
Composite Triple Beat	dB	66	4
Cross Modulation	dB	60	4,11
Composite Second Order (high side)	dB	64	4
64 PAL I channels (CW) with digital			9
Composite Beat	dB	59	4
Cross Modulation	dB	59	4,11
42 CENELEC channels (CW)			10
Composite Triple Beat	dBuV	112.5	
Cross Modulation	dBuV	113.	
Composite Second Order (high side)	dBuV	115.5	
78 NTSC channels (CW) with digital			7
Composite Triple Beat	dB	65	4
Cross Modulation	dB	59	4,11
Composite Second Order (high side)	dB	64	4

Product Specifications

Table 4. Launch Amplifier Performance - Reverse

Reverse Station Performance	Units	Reverse	Notes
Amplifier Type	-	GaAs FET	
Operational Gain (minimum)	dB	-2	5,6
Frequency Response	dB	0.5	
Internal Tilt (± 1 dB)	dB	0	
Path to Path Isolation	dB	50	
Noise Figure	dB	13.5	6

Table 5. RF Delay Specifications

Station Delay Characteristics			
Forward (Chrominance to Luminance Delay)		Reverse (Group Delay in 1.5 MHz BW)	
Frequency (MHz)	Delay (nS)	Frequency (MHz)	Delay (nS)
112.25 - 116.68	2	5.0 - 6.5	33
119.25 - 123.68	2	6.5 - 8.0	15
126.25 - 130.68	2	8.0 - 9.5	8
		60.5 - 62.0	5
		62.0 - 63.5	7
		63.5 - 65.0	10

RF Section Notes:

- Reference output tilt and internal tilt are both "Linear" tilt.
- Forward internal tilt specified is primarily due to an on-board equalizer and a factory configured linear interstage equalizer (ISEQ).
- The forward reference output tilt specified is achieved via field installation of appropriate input EQ, in conjunction with the internal tilt of the launch amplifier and the tilt associated with the optical link (transmitter/receiver combination).
- Station performance can be determined by combining optic performance and launch amplifier performance. Stated distortion performance is for launch amplifier section operated at reference output levels and tilt.
- Reverse Operational Gain is measured from the reverse RF input port to the RF input to the reverse transmitter and includes optical interface board losses.
- Reverse Gain and Noise Figure for launch amp with 0 dB reverse input pad and 0 dB output pad.
- Loaded with 78 NTSC CW carriers from 91-550 MHz. "Digital" refers to 550 - 1002 MHz loading with QAM carriers at -6 dB relative to analog video carrier levels.
- Loaded with 64 PAL B/G CW carriers from 112-600 MHz. "Digital" refers to 600 - 1002 MHz loading with QAM carriers at -6 dB relative to analog video carrier levels.
- Loaded with 64 PAL I CW carriers from 88-600 MHz. "Digital" refers to 600 - 1002 MHz loading with QAM carriers at -6 dB relative to analog video carrier levels.
- Tested per CENELEC Standard EN50083-3. RF output level is at 870 MHz (forward).
- X-mod (@ 15.75 kHz) specified using 100% synchronous modulation and frequency selective measurement device.

Product Specifications

Table 6. Electrical Specifications

Electrical	Units	Value			Notes
Max. AC Through Current (continuous)	Amps	15			
Max. AC Through Current (surge)	Amps	25			
Component DC Power Consumption (typical)		@ +24 VDC	@ +15 VDC	@ -6 VDC	1
Launch Amplifier HGBT	Amps	2.60			
Status Monitoring Transponder	Amps	0.15			
Standard Optical Receiver	Amps	0.25	0.01	0.035	
Reverse Transmitter – High Gain FP	Amps	0.09	-	0.07	
Reverse Transmitter – High Gain DFB	Amps	0.11	-	0.09	
Power Supply DC Current Rating	Amps	3.5	0.05	0.35	1

Note:

- The total DC Power consumption of installed components should not exceed the power supply DC current rating.

Table 7. Electrical Specifications – Station Powering Data

GainMaker 4-Port Node, 2 Transmitters, 1 Receiver, 1 Status Monitor, 1 Launch Amplifier						
DC Current	24 VDC @ 3.2A, 15 VDC @ 0.01A, and -6 VDC @ 0.215A					
AC Voltage	90	80	70	60	50	40
AC Current (A)	1.21	1.26	1.45	1.69	1.97	2.47
AC Power (W)	92.31	91.67	90.91	90.49	90.22	90.5

Table 8. Environmental Specifications

Environmental	Units	Value
Operating Temperature Range	F/ C	-40 to 140 F (-40 to 60 C)
Relative Humidity Range	%	5 to 95%
Mechanical		
Housing Dimensions (L x H x D)	in./mm	17.6 in. x 7.5 in. x 7.9 in. (447 mm x 191 mm x 201 mm)
Weight (Station with 1 RX, 1 TX, and power supply)	lb/kg	22.5 lb (10.2 kg)

Ordering Information

The GainMaker High Output 4-Port Node is available in a wide variety of configurations. The GainMaker Ordering Matrix provides ordering information for configured node stations and launch amplifiers. This page contains ordering information for required and optional accessories. Please consult with your Account Representative, Customer Service Representative, or Applications Engineer to determine the best configuration for your particular application.

Table 9. Required Accessories

Required Accessories for RF Module	Part Number
Plug-in Pads (attenuators) - Available in 0.5 dB steps from 0 to 20 dB <ul style="list-style-type: none"> • 1 required for forward input • 6 required for reverse (4 input, 2 output) 	589693 (0 dB) sequentially thru 589734 (20.5 dB)
Plug-in Forward Linear Equalizer - Available in 1.5 dB steps from 0 to 30 dB at 1002 MHz <ul style="list-style-type: none"> • 1 required for forward input 	See EQ Table Below
Required Accessories for Optical Components	Part Number
Plug-in Pads (attenuators) - Available in 0.5 dB steps from 0 to 20.5 dB <ul style="list-style-type: none"> • 1 ea required for Transmitter and Receiver(s). 	279500 (0 dB) sequentially thru 279513 (13 dB) in 1 dB steps
	504151 (14 dB) sequentially thru 504157 (20 dB) in 1 dB steps
	565231 (0.5 dB) sequentially thru 565251 (20.5 dB) in 1 dB steps

Note: Configured Nodes ship without reverse input pads and without forward input pads or EQ. All other accessories are shipped from the factory. Forward launch amplifier attenuator pads, interstage EQ and system trim are shipped with every configured node.

Table 10. Optional Accessories

Optional Accessories for RF Module	Part Number	
Reverse Configuration Module – Segmented (box of 5)	4018565	
Reverse Configuration Module - Non-Segmented (box of 5)	4018564	
Optional Accessories for Optical Components	Part Number	
Redundancy Jumper Module Plug-in – Redundant (box of 5)	4018565	
Redundancy Jumper Module Plug-in – Non-Redundant (box of 5)	4018564	
Launch Amplifier Module	Part Number on Module	Part Number for Ordering
GainMaker High Output 4-Port Launch Amplifier 55/70 MHz	4030931	4030926
Forward Linear Equalizers	Part Number on Module	Part Number for Ordering
0 dB 1GHz Forward Linear EQ	-	4007228
1.5 dB 1GHz Forward Linear EQ	-	4008778
3.0 dB 1GHz Forward Linear EQ	-	4008779
4.5 dB 1GHz Forward Linear EQ	-	4008780
6.0 dB 1GHz Forward Linear EQ	-	4008781
7.5 dB 1GHz Forward Linear EQ	-	4008782
9.0 dB 1GHz Forward Linear EQ	-	4008783
10.5 dB 1GHz Forward Linear EQ	-	4008784
12.0 dB 1GHz Forward Linear EQ	-	4008785
13.5 dB 1GHz Forward Linear EQ	-	4008786

15.0 dB 1GHz Forward Linear EQ	-	4008787
16.5 dB 1GHz Forward Linear EQ	-	4019258
18.0 dB 1GHz Forward Linear EQ	-	4019259
19.5 dB 1GHz Forward Linear EQ	-	4019260
21.0 dB 1GHz Forward Linear EQ	-	4019261

Table 11. Transmitters & Receivers

Optical Transmitters and Receivers (available as part of configuration or separately)	Part Number on Module	Part Number for Ordering
Receivers		
GainMaker Node Optical Receiver with SC/APC connector	4007501	4007671
GainMaker Node Optical Receiver with SC/UPC connector	4007502	4007672
GainMaker Node Optical Receiver with FC/APC connector	4007503	4007673
Analog FP Transmitters		
FP Optical Transmitter – High Gain 1310 nm with SC/APC connector	717908	590942
FP Optical Transmitter – High Gain 1310 nm with SC/UPC connector	717909	590943
FP Optical Transmitter – High Gain 1310 nm with FC/APC connector	717906	590940
Analog DFB Transmitters		
DFB Optical Transmitter – High Gain, 1310 nm with SC/APC connector	4013906.1310	590938
DFB Optical Transmitter – High Gain, 1310 nm with SC/UPC connector	4013907.1310	590939
DFB Optical Transmitter – High Gain, 1310 nm with FC/APC connector	4013896.1310	590936
Analog CWDM Transmitters		
CWDM DFB Optical Transmitter – High Gain 1470 nm with SC/APC connector	4013906.1470	4007003
CWDM DFB Optical Transmitter – High Gain 1490 nm with SC/APC connector	4013906.1490	4007004
CWDM DFB Optical Transmitter – High Gain 1510 nm with SC/APC connector	4013906.1510	4007005
CWDM DFB Optical Transmitter – High Gain 1530 nm with SC/APC connector	4013906.1530	4007006
CWDM DFB Optical Transmitter – High Gain 1550 nm with SC/APC connector	4013906.1550	4007007
CWDM DFB Optical Transmitter – High Gain 1570 nm with SC/APC connector	4013906.1570	4007008
CWDM DFB Optical Transmitter – High Gain 1590 nm with SC/APC connector	4013906.1590	4007009
CWDM DFB Optical Transmitter – High Gain 1610 nm with SC/APC connector	4013906.1610	4007010
CWDM DFB Optical Transmitter – High Gain 1470 nm with SC/UPC connector	4013907.1470	4007011
CWDM DFB Optical Transmitter – High Gain 1490 nm with SC/UPC connector	4013907.1490	4007012
CWDM DFB Optical Transmitter – High Gain 1510 nm with SC/UPC connector	4013907.1510	4007013
CWDM DFB Optical Transmitter – High Gain 1530 nm with SC/UPC connector	4013907.1530	4007014
CWDM DFB Optical Transmitter – High Gain 1550 nm with SC/UPC connector	4013907.1550	4007015
CWDM DFB Optical Transmitter – High Gain 1570 nm with SC/UPC connector	4013907.1570	4007016
CWDM DFB Optical Transmitter – High Gain 1590 nm with SC/UPC connector	4013907.1590	4007017
CWDM DFB Optical Transmitter – High Gain 1610 nm with SC/UPC connector	4013907.1610	4007018
CWDM DFB Optical Transmitter – High Gain 1470 nm with FC/APC connector	4013908.1470	4007019
CWDM DFB Optical Transmitter – High Gain 1490 nm with FC/APC connector	4013908.1490	4007020
CWDM DFB Optical Transmitter – High Gain 1510 nm with FC/APC connector	4013908.1510	4007021
CWDM DFB Optical Transmitter – High Gain 1530 nm with FC/APC connector	4013908.1530	4007022
CWDM DFB Optical Transmitter – High Gain 1550 nm with FC/APC connector	4013908.1550	4007023
CWDM DFB Optical Transmitter – High Gain 1570 nm with FC/APC connector	4013908.1570	4007024
CWDM DFB Optical Transmitter – High Gain 1590 nm with FC/APC connector	4013908.1590	4007025
CWDM DFB Optical Transmitter – High Gain 1610 nm with FC/APC connector	4013908.1610	4007026
Analog DWDM TX		
DWDM Analog Optical Transmitter, CH. 20, 1561.42 nm with SC/APC connector	4023375.20	4023375.20
DWDM Analog Optical Transmitter, CH. 21, 1560.61 nm with SC/APC connector	4023375.21	4023375.21
DWDM Analog Optical Transmitter, CH. 22, 1559.79 nm with SC/APC connector	4023375.22	4023375.22
DWDM Analog Optical Transmitter, CH. 23, 1558.98 nm with SC/APC connector	4023375.23	4023375.23
DWDM Analog Optical Transmitter, CH. 24, 1558.17 nm with SC/APC connector	4023375.24	4023375.24
DWDM Analog Optical Transmitter, CH. 25, 1557.36 nm with SC/APC connector	4023375.25	4023375.25
DWDM Analog Optical Transmitter, CH. 26, 1556.55 nm with SC/APC connector	4023375.26	4023375.26
DWDM Analog Optical Transmitter, CH. 27, 1555.75 nm with SC/APC connector	4023375.27	4023375.27
DWDM Analog Optical Transmitter, CH. 28, 1554.94 nm with SC/APC connector	4023375.28	4023375.28
DWDM Analog Optical Transmitter, CH. 29, 1554.13 nm with SC/APC connector	4023375.29	4023375.29

DWDM Analog Optical Transmitter, CH. 30, 1553.33 nm with SC/APC connector	4023375.30	4023375.30
DWDM Analog Optical Transmitter, CH. 31, 1552.52 nm with SC/APC connector	4023375.31	4023375.31
DWDM Analog Optical Transmitter, CH. 32, 1551.72 nm with SC/APC connector	4023375.32	4023375.32
DWDM Analog Optical Transmitter, CH. 33, 1550.92 nm with SC/APC connector	4023375.33	4023375.33
DWDM Analog Optical Transmitter, CH. 34, 1550.12 nm with SC/APC connector	4023375.34	4023375.34
DWDM Analog Optical Transmitter, CH. 35, 1549.32 nm with SC/APC connector	4023375.35	4023375.35
DWDM Analog Optical Transmitter, CH. 36, 1548.51 nm with SC/APC connector	4023375.36	4023375.36
DWDM Analog Optical Transmitter, CH. 37, 1547.72 nm with SC/APC connector	4023375.37	4023375.37
DWDM Analog Optical Transmitter, CH. 38, 1546.92 nm with SC/APC connector	4023375.38	4023375.38
DWDM Analog Optical Transmitter, CH. 39, 1546.12 nm with SC/APC connector	4023375.39	4023375.39
DWDM Analog Optical Transmitter, CH. 40, 1545.32 nm with SC/APC connector	4023375.40	4023375.40
DWDM Analog Optical Transmitter, CH. 41, 1544.53 nm with SC/APC connector	4023375.41	4023375.41
DWDM Analog Optical Transmitter, CH. 42, 1543.73 nm with SC/APC connector	4023375.42	4023375.42
DWDM Analog Optical Transmitter, CH. 43, 1542.94 nm with SC/APC connector	4023375.43	4023375.43
DWDM Analog Optical Transmitter, CH. 44, 1542.14 nm with SC/APC connector	4023375.44	4023375.44
DWDM Analog Optical Transmitter, CH. 45, 1541.35 nm with SC/APC connector	4023375.45	4023375.45
DWDM Analog Optical Transmitter, CH. 46, 1540.56 nm with SC/APC connector	4023375.46	4023375.46
DWDM Analog Optical Transmitter, CH. 47, 1539.77 nm with SC/APC connector	4023375.47	4023375.47
DWDM Analog Optical Transmitter, CH. 48, 1538.98 nm with SC/APC connector	4023375.48	4023375.48
DWDM Analog Optical Transmitter, CH. 49, 1538.19 nm with SC/APC connector	4023375.49	4023375.49
DWDM Analog Optical Transmitter, CH. 50, 1537.40 nm with SC/APC connector	4023375.50	4023375.50
DWDM Analog Optical Transmitter, CH. 51, 1536.61 nm with SC/APC connector	4023375.51	4023375.51
DWDM Analog Optical Transmitter, CH. 52, 1535.82 nm with SC/APC connector	4023375.52	4023375.52
DWDM Analog Optical Transmitter, CH. 53, 1535.04 nm with SC/APC connector	4023375.53	4023375.53
DWDM Analog Optical Transmitter, CH. 54, 1534.25 nm with SC/APC connector	4023375.54	4023375.54
DWDM Analog Optical Transmitter, CH. 55, 1533.47 nm with SC/APC connector	4023375.55	4023375.55
DWDM Analog Optical Transmitter, CH. 56, 1532.68 nm with SC/APC connector	4023375.56	4023375.56
DWDM Analog Optical Transmitter, CH. 57, 1531.90 nm with SC/APC connector	4023375.57	4023375.57
DWDM Analog Optical Transmitter, CH. 58, 1531.12 nm with SC/APC connector	4023375.58	4023375.58
DWDM Analog Optical Transmitter, CH. 59, 1530.33 nm with SC/APC connector	4023375.59	4023375.59

Table 12. Related Equipment

Related Equipment (available as part of configuration or separately)	Part Number on Module	Part Number for Ordering
High Output 4-Port GainMaker Node – Standard DC Power Supply 40 - 90 V AC	4027978	4027962
High Output 4-Port GainMaker Node Status Monitoring Transponder (See Transponder Data Sheet)	4027979	4027963



Cisco, Cisco Systems, the Cisco logo, and the Cisco Systems logo are registered trademarks or trademarks of Cisco Systems, Inc. and/or its affiliates in the U.S. and certain other countries.

All other trademarks mentioned in this document are trademarks of their respective owners.

Specifications and product availability are subject to change without notice.

© 2009 Cisco Systems, Inc. All rights reserved.

Cisco Systems, Inc.
1-800-722-2009 or 678-277-1120

Part Number 7017843 Rev A
August 2009