



Cisco UCS B230 M2 Blade Server

CISCO SYSTEMS
170 WEST TASMAN DR.
SAN JOSE, CA, 95134
WWW.CISCO.COM

PUBLICATION HISTORY

REV A.2 APRIL 3, 2012

CONTENTS

OVERVIEW	3
DETAILED VIEWS	4
Chassis Front View	4
BASE SERVER STANDARD CAPABILITIES and FEATURES	5
CONFIGURING the SERVER	6
STEP 1 VERIFY BASE SKU	7
STEP 2 CHOOSE CPU(S)	8
STEP 3 CHOOSE MEMORY	9
STEP 4 CHOOSE SOLID STATE DRIVES	12
STEP 5 CHOOSE MEZZANINE OPTION CARD	13
STEP 6 CHOOSE OPERATING SYSTEM	14
STEP 7 CHOOSE OPERATING SYSTEM MEDIA KIT	16
STEP 8 CHOOSE OPTIONAL VALUE-ADDED SOFTWARE	17
STEP 9 CHOOSE SERVICE and SUPPORT LEVEL	18
ORDER OPTIONAL KVM CABLE	22
SUPPLEMENTAL MATERIAL	23
Motherboard	23
DIMM and CPU Layout	24
Memory Population Recommendations	25
TECHNICAL SPECIFICATIONS	27
Dimensions and Weight	27
Power Specifications	27

OVERVIEW

The Cisco® UCS B230 M2 Blade Server is a two-socket, half-width blade server that extends the capabilities of the Cisco Unified Computing System™, using Intel's Xeon E7-2800 and E7-8800 Series multi-core processors with 32 DIMM slots, one mezzanine slot, and up to two solid-state drives (SSDs). Up to eight half-width blade servers can be accommodated in the Cisco UCS 5108 Blade Server Chassis. The UCS B230 M2 server is shown in [Figure 1](#).

Figure 1 Cisco UCS B230 M2 Blade Server



DETAILED VIEWS

Chassis Front View

Figure 2 shows the front of the Cisco UCS B230 M2 Blade Server.

Figure 2 Chassis Front View

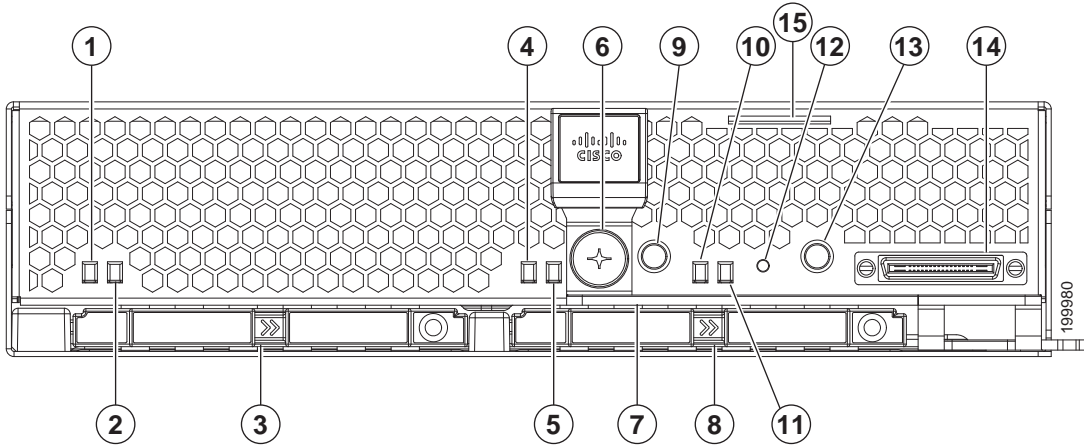

1	SSD 1 activity LED	9	Beaoning LED and button
2	SSD 1 Fault/Locate LED	10	System activity LED
3	SSD sled in bay 1	11	Blade health LED
4	SSD 2 activity LED	12	Reset button access
5	SSD 2 fault LED	13	Power button and LED
6	Ejector lever captive screw	14	Console connector ¹
7	Ejector lever	15	Asset tab ²
8	SSD sled in bay 2	-	-

Notes . . .

1. For more information regarding the KVM cable connection, see [ORDER OPTIONAL KVM CABLE on page 22](#)
2. Each server has a blank plastic tag that pulls out of the front panel, provided so you can add your own asset tracking label without interfering with the intended air flow

BASE SERVER STANDARD CAPABILITIES and FEATURES

Table 1 lists the capabilities and features of the base server. Details about how to configure the server for a particular feature or capability (for example, number of processors, disk drives, or amount of memory) are provided in [CONFIGURING the SERVER on page 6](#).

Table 1 Capabilities and Features

Capability/Feature	Description
Chassis	The B230 M2 Blade Server mounts in a Cisco UCS 5100-series chassis
CPU	Either 1 or 2 Intel® Xeon® E7-2800 or E7-8800 series processors
Chipset	Intel® 7510 chipset
Memory	32 slots for registered DIMMs, up to 512 GB.
Expansion slots	One mezzanine slot is provided
Storage controller	LSI SAS 2008 RAID controller (onboard version of LSI MegaRAID 9240)
Internal storage devices	Up to two optional front-accessible, hot-swappable low-height 7 mm form factor SATA solid-state disk drives (SSDs).
Video	The server CIMC chip includes a Matrox G200 core. The first 8 MB of memory are allocated to the video core.
Interfaces	Front panel <ul style="list-style-type: none"> ■ One console connector (see ORDER OPTIONAL KVM CABLE on page 22)
Power subsystem	Integrated in the Cisco UCS 5100 series chassis
Fans	Integrated in the Cisco UCS 5100 series chassis
Integrated management processor	The built-in Cisco Integrated Management Controller (CIMC) GUI or CLI interface enables you to monitor the server inventory, health, and system event logs.

CONFIGURING the SERVER

Follow these steps to configure the Cisco UCS B230 M2 Server:

- [STEP 1 VERIFY BASE SKU, page 7](#)
- [STEP 2 CHOOSE CPU\(S\), page 8](#)
- [STEP 3 CHOOSE MEMORY, page 9](#)
- [STEP 4 CHOOSE SOLID STATE DRIVES, page 12](#)
- [STEP 5 CHOOSE MEZZANINE OPTION CARD, page 13](#)
- [STEP 6 CHOOSE OPERATING SYSTEM, page 14](#)
- [STEP 7 CHOOSE OPERATING SYSTEM MEDIA KIT, page 16](#)
- [STEP 8 CHOOSE OPTIONAL VALUE-ADDED SOFTWARE, page 17](#)
- [STEP 9 CHOOSE SERVICE and SUPPORT LEVEL, page 18](#)

STEP 1 VERIFY BASE SKU

Verify the product ID (PID) of the base server as shown in [Table 2](#).

Table 2 PID of the Base B230 M2 Server

Product ID (PID)	Description
B230-BASE-M2	UCS B230 M2 Blade Server w/o CPU, memory, SSD, mezzanine

The B230-BASE-M2 base server:

- Does not include CPUs, memory DIMMs, solid-state Drives (SSDs), or a mezzanine card.



NOTE: Use the steps on the following pages to configure the server with the components that you want to include.

STEP 2 CHOOSE CPU(S)

The standard CPU features are:

- Intel Xeon E7-2800 or E7-8800 series CPUs
- Cache size of 18, 24, or 30 MB

Choose CPUs

The available CPUs are listed in [Table 3](#).

Table 3 Available CPUs: Intel Xeon E7-28xx/8867L Family

Product ID (PID)	Intel Number	Clock Freq (GHz)	Power (W)	Cache Size (MB)	Cores	QPI	Highest DDR3 DIMM Clock Support (MHz)
UCS-CPU-E72870	E7-2870	2.40	130	30	10	6.40	1333
UCS-CPU-E72860	E7-2860	2.26	130	24	10	6.40	1333
UCS-CPU-E27830	E7-2830	2.13	105	24	8	6.40	1333
UCS-CPU-E78867L	E7-8867L	2.13	105	30	10	6.40	1333
UCS-CPU-E72850	E7-2850	2.00	130	24	10	6.40	1333
UCS-CPU-E72803	E7-2803	1.73	105	18	6	4.80	1333

Approved Configurations

(1) One-CPU Configuration

- Choose one CPU from [Table 3](#).

(2) Two-CPU Configuration

- Choose two CPUs from any one row of [Table 3](#).

Caveats

- You must choose one processor or two identical processors.

STEP 3 CHOOSE MEMORY

The standard memory features are:

- DIMMs
 - Maximum memory bandwidth: 1066 MHz
 - Ranks per DIMM: 1, 2, or 4
 - Operational voltage: 1.35 V
 - Registered
- Each CPU controls four DDR3 channels. Each of the channels controls four DIMMs. The total number of DIMMs that can be installed per CPU is 16 (8 DIMM kits). See [Figure 3](#).



NOTE: Memory mirroring is supported and settable using the UCSM Service Profile “Memory RAS Configuration” setting.

Figure 3 B230 M2 Memory Organization

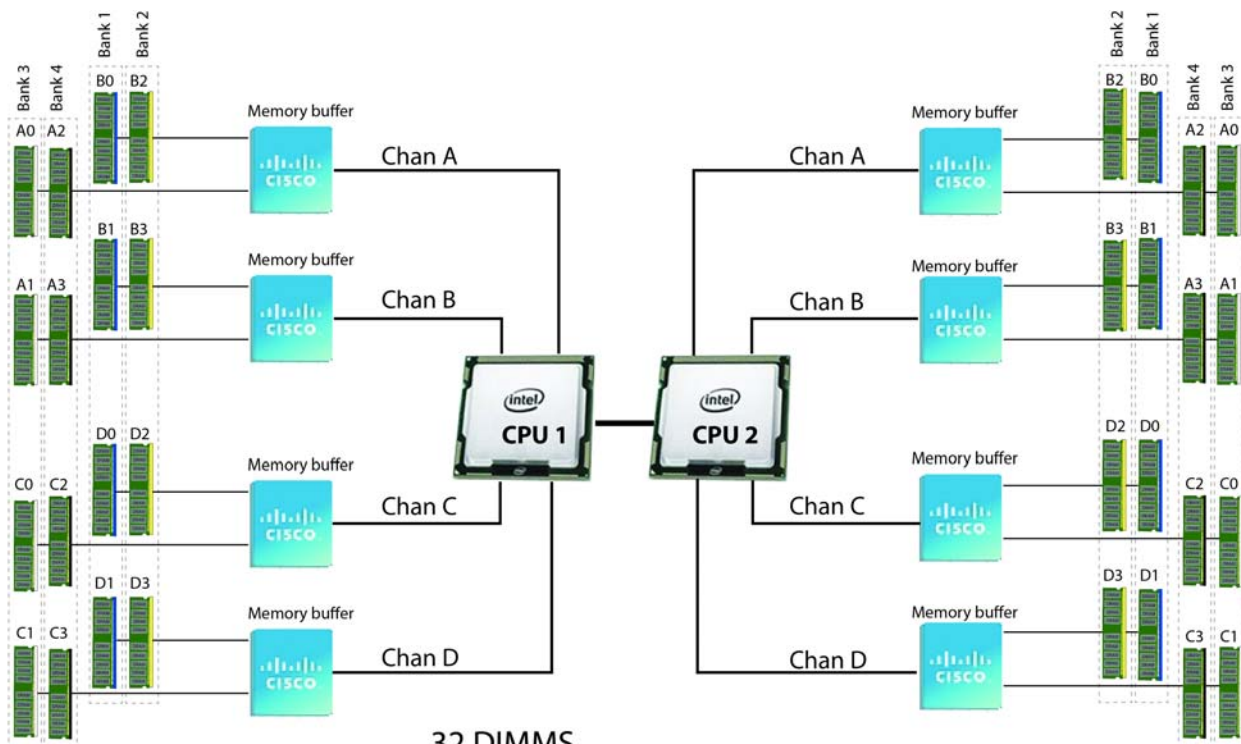

32 DIMMS
 512 GB maximum memory
 4 memory channels per CPU,
 up to 4 DIMMs per channel

Select DIMMs

DIMMs are available as two-DIMM kits. Each of the product IDs in [Table 4](#) specifies two DIMMs.

Table 4 Available DDR3 DIMMs

Product ID (PID)	PID Description	Voltage	Ranks/ DIMM
DIMM Pair Kit Options (2 DIMMs per kit)			
UCS-MR-2X041RX-C	2X4GB DDR3-1333-MHz RDIMM/PC3-10600/1R/x4/1.35V	1.35 V	1
UCS-MR-2X082RX-C	2X8GB DDR3-1333-MHz RDIMM/PC3-10600/2R/x4/1.35V	1.35 V	2
UCS-MR-2X164RX-D	2X16GB NHS DDR3-1333-MHz RDIMM/PC3-10600/4R/x4/1.35V	1.35 V	4
A02-M332GD3-2-L	2X16GB NHS DDR3-1066MHz RDIMM/PC3-8500/4R/1.35V	1.35 V	4

Approved Configurations

(1) 1-CPU Configuration

- 16 DIMMs capacity total
- Select from one to eight DIMM kits (two to 16 DIMMs) per CPU. The DIMMs will be placed by the factory as shown in the following table:

Number of DIMMs	DIMM Placement in Numbered/Colored DIMM Slots (see Figure 7 on page 25)
2	(B0, B1) - blue slots
4	(B0, B1) - (D0, D1) - blue slots
6	(B0, B1) - (D0, D1) - blue slots; (A0, A1) - white slots
8	(B0, B1) - (D0, D1) - blue slots; (A0, A1) - (C0, C1) - white slots
10	(B0, B1) - (D0, D1) - blue slots; (A0, A1) - (C0, C1) - white slots; (B2, B3) - yellow slots
12	(B0, B1) - (D0, D1) - blue slots; (A0, A1) - (C0, C1) - white slots (B2, B3) - (D2, D3) - yellow slots
14	(B0, B1) - (D0, D1) - blue slots; (A0, A1) - (C0, C1) - white slots (B2, B3) - (D2, D3) - yellow slots; (A2, A3) - black slots
16	(B0, B1) - (D0, D1) - blue slots; (A0, A1) - (C0, C1) - white slots (B2, B3) - (D2, D3) - yellow slots; (A2, A3) - (C2, C3) - black slots

(2) 2-CPU Configuration

- 32 DIMMs capacity total
- Select from one to eight DIMM kits (two to 16 DIMMs) per CPU. The DIMMs will be placed by the factory as shown in the following table:

Number of DIMMs per CPU	DIMM Placement in Numbered/Colored DIMM Slots (see Figure 7 on page 25)
2	CPU 1: (B0, B1) - blue slots CPU 2: (B0, B1) - blue slots
4	CPU 1: (B0, B1) - (D0, D1) - blue slots CPU 2: (B0, B1) - (D0, D1) - blue slots
6	CPU 1: (B0, B1) - (D0, D1) - blue slots; (A0, A1) - white slots CPU 2: (B0, B1) - (D0, D1) - blue slots; (A0, A1) - white slots
8	CPU 1: (B0, B1) - (D0, D1) - blue slots; (A0, A1) - (C0, C1) - white slots CPU 2: (B0, B1) - (D0, D1) - blue slots; (A0, A1) - (C0, C1) - white slots
10	CPU 1: (B0, B1) - (D0, D1) - blue slots; (A0, A1) - (C0, C1) - white slots; (B2, B3) - yellow slots CPU 2: (B0, B1) - (D0, D1) - blue slots; (A0, A1) - (C0, C1) - white slots; (B2, B3) - yellow slots
12	CPU 1: (B0, B1) - (D0, D1) - blue slots; (A0, A1) - (C0, C1) - white slots (B2, B3) - (D2, D3) - yellow slots CPU 2: (B0, B1) - (D0, D1) - blue slots; (A0, A1) - (C0, C1) - white slots (B2, B3) - (D2, D3) - yellow slots
14	CPU 1: (B0, B1) - (D0, D1) - blue slots; (A0, A1) - (C0, C1) - white slots (B2, B3) - (D2, D3) - yellow slots; (A2, A3) - black slots CPU 2: (B0, B1) - (D0, D1) - blue slots; (A0, A1) - (C0, C1) - white slots (B2, B3) - (D2, D3) - yellow slots; (A2, A3) - black slots
16	CPU 1: (B0, B1) - (D0, D1) - blue slots; (A0, A1) - (C0, C1) - white slots (B2, B3) - (D2, D3) - yellow slots; (A2, A3) - (C2, C3) - black slots CPU 2: (B0, B1) - (D0, D1) - blue slots; (A0, A1) - (C0, C1) - white slots (B2, B3) - (D2, D3) - yellow slots; (A2, A3) - (C2, C3) - black slots

Caveats

- The B230 M2 server needs at least one DIMM pair installed for CPU 1 or CPU 2.
- One DIMM pair on a CPU can be different from other pairs; however, DIMMs sold as kits are matched pairs and must remain together when installed in a particular pair of same-colored (blue, white, yellow, or black) pairs of slots.
- The DIMMs installed in slots for an absent CPU are not recognized.
- Memory DIMMs should be installed evenly across the installed CPUs, though it is not a requirement. The preferred DIMM installations are highlighted in green in the tables.

STEP 4 CHOOSE SOLID STATE DRIVES

The standard disk drive features are:

- 7 mm low-height form factor solid state drives
- Hot-pluggable
- Sled-mounted

Choose Drives

The available drives are listed in [Table 5](#).

Table 5 Available Hot-Pluggable Sled-Mounted SSDs

Product ID (PID)	PID Description	Drive Type	Capacity
N20-D032SSD	32 GB Low-Height 7mm SATA SSD	SATA	32 GB
UCS-SSD100G11F105	100 GB Low-Height 7mm SATA SSD	SATA	100 GB

Approved Configurations

(1) 1-Drive Configuration

- Select one drive from [Table 5](#).

(2) 2-Drive Configuration

- Select two drives from [Table 5](#).

Caveats

- None

STEP 5 CHOOSE MEZZANINE OPTION CARD

The standard PCIe card offerings are:

- Converged Network Adapters (CNA)
- Network Interface Cards (NICs)

Choose a PCIe Option Card

The available PCIe option cards are listed in [Table 6](#).

Table 6 Available PCIe Option Cards

Product ID (PID)	PID Description
Converged Network Adapters (CNA)	
N20-AC0002	UCS M81KR Virtual Interface Card/PCIe/2-port 10Gb
N20-AQ0102	Cisco UCS CNA M72KR-Q QLogic Converged Network Adapter
N20-AE0102	Cisco UCS CNA M72KR-E Emulex Converged Network Adapter
N20-AI0102	Cisco UCS CNA M61KR-I Intel Converged Network Adapter
Network Interface Cards (NICs)	
N20-AB0002	Cisco UCS NIC M51KR-B Broadcom BCM57711 Network Adapter

Approved Configurations

(1) Select one PCIe Mezzanine Card (mandatory)

You must select one card.

To help ensure that your operating system is compatible with the card you have selected, please check the Hardware Compatibility List at this URL:

http://www.cisco.com/en/US/products/ps10477/prod_technical_reference_list.html

STEP 6 CHOOSE OPERATING SYSTEM

Several operating systems are available from which to choose. Choose one of the operating systems listed in [Table 7](#).

Table 7 Operating Systems

PID Description	Product ID (PID)
Red Hat Enterprise Linux	
RHEL-2S-1G-1A	RHEL/2 Socket/1 Guest/1Yr Svcs Required
RHEL-2S-1G-3A	RHEL/2 Socket/1 Guest/3Yr Svcs Required
RHEL-2S-4G-1A	RHEL/2 Socket/4 Guest/1Yr Svcs Required
RHEL-2S-4G-3A	RHEL/2 Socket/4 Guest/3Yr Svcs Required
RHEL-2S-UG-1A	RHEL/2 Socket/U Guest/1Yr Svcs Required
RHEL-2S-UG-3A	RHEL/2 Socket/U Guest/3Yr Svcs Required
RHEL-2S-1G-1A-RS	RHEL/2 Socket/1 Guest/1Yr Subscription/Redhat Svcs Included
RHEL-2S-1G-3A-RS	RHEL/2 Socket/1 Guest/3Yr Subscription/Redhat Svcs Included
RHEL-2S-4G-3A-RS	RHEL/2 Socket/2 Guest/3Yr Subscription/Redhat Svcs Included
RHEL-2S-4G-1A-RS	RHEL/2 Socket/4 Guest/1Yr Subscription/Redhat Svcs Included
RHEL-2S-UG-1A-RS	RHEL/2 Socket/U Guest/1Yr Subscription/Redhat Svcs Included
RHEL-2S-UG-3A-RS	RHEL/2 Socket/U Guest/3Yr Subscription/Redhat Svcs Included
RHEL Add-Ons	
RHEL-HA-2S-1A	RHEL Option/High-Availability/2 Socket/1Yr Svcs Required
RHEL-RS-2S-1A	RHEL Option/Resilient w/Ha /2 Socket/1 Yr Svcs Required
RHEL-SFS-2S-1A	RHEL Option/Scalable File System/2 Socket/1 Yr Svcs Required
RHEL-HA-2S-3A	RHEL Option/High-Availability/2 Socket/3Yr Svcs Required
RHEL-RS-2S-3A	RHEL Option/Resilient Storage w/ HA /2 Socket/3 Yr Svcs Req'd
RHEL-SFS-2S-3A	RHEL Option/Scalable File System/2 Socket/3 Yr Svcs Required
RHEL-HA-2S-1A-RS	RHEL Option/High-Availability/2 Socket/1Yr Redhat Svcs Incl'd
RHEL-RS-2S-1A-RS	RHEL Option/Resilient Storage/2 Socket/1 Yr Redhat Svcs Incl
RHEL-SFS-2S-1A-RS	RHEL Option/Scalable File Sys/2 Socket/1 Yr Redhat Svcs Incl
RHEL-HA-2S-3A-RS	RHEL Option/High-Availability/2 Socket/3Yr Redhat Svcs Incl'd
RHEL-RS-2S-3A-RS	RHEL Option/Resilient Storage/2 Socket/3 Yr Redhat Svcs Incl
RHEL-SFS-2S-3A-RS	RHEL Option/Scalable File Sys/2 Socket/3 Yr Redhat Svcs Incl
Windows Server	
MSWS-08R2-STHV	Windows Svr 2008 ST media R2 ST (1-4CPU, 5CAL)
MSWS-08R2-ENHV	Windows Svr 2008 EN media R2 EN (1-8CPU, 25CAL)
MSWS-08R2-DCHV2S	Windows Svr 2008 R2-2 CPU-Data Center

Table 7 Operating Systems *(continued)*

PID Description	Product ID (PID)
MSWS-08R2-DCHV4S	Windows Svr 2008 R2-4 CPU-Data Center
VMWare Server	
VMW-VS5-STD-1A	VMware vSphere 5 Standard for 1 Processor, 1 Year, Support Req
VMW-VS5-STD-2A	VMware vSphere 5 Standard for 1 Processor, 2 Year, Support Req
VMW-VS5-STD-3A	VMware vSphere 5 Standard for 1 Processor, 3 Year, Support Req
VMW-VS5-STD-4A	VMware vSphere 5 Standard for 1 Processor, 4 Year, Support Req
VMW-VS5-STD-5A	VMware vSphere 5 Standard for 1 Processor, 5 Year, Support Req
VMW-VS5-ENT-1A	VMware vSphere 5 Enterprise for 1 Processor, 1 Year Support Req
VMW-VS5-ENT-2A	VMware vSphere 5 Enterprise for 1 Processor, 2 Year Support Req
VMW-VS5-ENT-3A	VMware vSphere 5 Enterprise for 1 Processor, 3 Year Support Req
VMW-VS5-ENT-4A	VMware vSphere 5 Enterprise for 1 Processor, 4 Year Support Req
VMW-VS5-ENT-5A	VMware vSphere 5 Enterprise for 1 Processor, 5 Year Support Req
VMW-VS5-ENTP-1A	VMware vSphere 5 Enterprise Plus for 1 Processor, 1 Year, Supp Req
VMW-VS5-ENTP-2A	VMware vSphere 5 Enterprise Plus for 1 Processor, 2 Year, Supp Req
VMW-VS5-ENTP-3A	VMware vSphere 5 Enterprise Plus for 1 Processor, 3 Year, Supp Req
VMW-VS5-ENTP-4A	VMware vSphere 5 Enterprise Plus for 1 Processor, 4 Year, Supp Req
VMW-VS5-ENTP-5A	VMware vSphere 5 Enterprise Plus for 1 Processor, 5 Year, Supp Req
VMW-VC5-ST-1A	VMware vCenter 5 Standard for 1 Processor, 1 Year, Support Required
VMW-VC5-ST-2A	VMware vCenter 5 Standard for 1 Processor, 2 Year, Support Required
VMW-VC5-ST-3A	VMware vCenter 5 Standard for 1 Processor, 3 Year, Support Required
VMW-VC5-ST-4A	VMware vCenter 5 Standard for 1 Processor, 4 Year, Support Required
VMW-VC5-ST-5A	VMware vCenter 5 Standard for 1 Processor, 5 Year, Support Required
Novell	
SLES-1A	SLES/1yr subscription/Svcs Required/0 media
SLES-3A	SLES/3yr subscription/Svcs Required/0 media

STEP 7 CHOOSE OPERATING SYSTEM MEDIA KIT

Choose the optional operating system media listed in [Table 8](#).

Table 8 OS Media

Product ID (PID)	PID Description
RHEL-6	RHEL 6 Recovery Media Only (Multilingual)
SLES-11	SLES 11 media only (multilingual)
MSWS-08R2-STHV-RM	Windows Svr 2008 R2 ST (1-4CPU, 5CAL), Media
MSWS-08RS-ENHV-RM	Windows Svr 2008 R2 EN (1-8CPU, 25CAL), Media
MSWS-08R2-DCHV-RM	Windows Svr 2008 R2 DC (1-8CPU, 25CAL), Media

STEP 8 CHOOSE OPTIONAL VALUE-ADDED SOFTWARE

You can select from a variety of value-added software listed in [Table 9](#).

Table 9 Value-Added Software

Product ID (PID)	PID Description
BMC-012	BMC BPPM Per Server
BMC-SE-4C	BMC BladeLogic Standard Edition, 4 Cores, Support Required
BMC-SE-6C	BMC BladeLogic Standard Edition, 6 Cores, Support Required
BMC-SE-8C	BMC BladeLogic Standard Edition, 8 Cores, Support Required
BMC-SE-10C	BMC BladeLogic Standard Edition, 10 Cores, Support Required
BMC-AE-4C	BMC BladeLogic Advanced Edition, 4 Cores, Support Required
BMC-AE-6C	BMC BladeLogic Advanced Edition, 6 Cores, Support Required
BMC-AE-8C	BMC BladeLogic Advanced Edition, 8 Cores, Support Required
BMC-AE-10C	BMC BladeLogic Advanced Edition, 10 Cores, Support Required
N1K-CSK9-UCS-404	Cisco Nexus 1000V VSM Virtual Appliance Software

STEP 9 CHOOSE SERVICE and SUPPORT LEVEL

A variety of service options are available, as described in this section.

Unified Computing Warranty, No Contract

If you have noncritical implementations and choose to have no service contract, the following coverage is supplied:

- Three-year parts coverage.
- Next business day on-site (NBD) on-site parts replacement eight hours a day, five days a week.
- 90-day software warranty on media.
- Downloads of BIOS, drivers, and firmware updates.
- UCSM updates for systems with Unified Computing System Manager. These updates include minor enhancements and bug fixes that are designed to maintain the compliance of UCSM with published specifications, release notes, and industry standards.

Unified Computing Mission Critical Service

This service delivers personalized technical account management, expedited technical support, and expert field support engineering for the Cisco Unified Computing System (UCS).

The Mission Critical Support Service provides a designated technical account manager (TAM) who acts as a strategic resource to help ensure that the unified computing environment runs at peak efficiency. If a problem arises that threatens business continuity, the TAM provides crisis management leadership, and your IT staff receives expedited access to Cisco's Technical Assistance Center (TAC).

Please note: This service has qualification criteria. Your company must have \$1.2M of UCS equipment, 200 blades and a single location to qualify for this service level. Choose the desired service listed in [Table 10](#).

Table 10 Unified Computing Mission Critical Service

Product ID (PID)	On Site?	Description
CON-UCM7-B230-M2	Yes	UC Mission Critical 24x7x4 On-site
CON-UCM8-B230-M2	Yes	UC Mission Critical 24x7x2 On-site

Unified Computing Support Service

For support of the entire Unified Computing System, Cisco offers the Cisco Unified Computing Support Service. This service provides expert software and hardware support to help sustain performance and high availability of the unified computing environment. Access to Cisco Technical Assistance Center (TAC) is provided around the clock, from anywhere in the world.

For UCS blade servers, there is Smart Call Home, which provides proactive, embedded diagnostics and real-time alerts. For systems that include Unified Computing System Manager, the support service includes downloads of UCSM upgrades. The Unified Computing Support Service includes flexible hardware replacement options, including replacement in as little as

two hours. There is also access to Cisco's extensive online technical resources to help maintain optimal efficiency and uptime of the unified computing environment. You can choose a desired service listed in [Table 11](#).

Table 11 UCS Computing Support Service

Product ID (PID)	On Site?	Description
CON-UCS1-B230-M2	No	UC Support 8X5XNBD
CON-UCS2-B230-M2	No	UC Support 8X5X4
CON-UCS3-B230-M2	No	UC Support 24x7x4
CON-UCS4-B230-M2	No	UC Support 24x7x2
CON-UCS5-B230-M2	Yes	UC Support 8X5XNBD
CON-UCS6-B230-M2	Yes	UC Support 8X5X4
CON-UCS7-B230-M2	Yes	UC Support 24x7x4
CON-UCS8-B230-M2	Yes	UC Support 24x7x2

Unified Computing Warranty Plus Service

For faster parts replacement than is provided with the standard Cisco Unified Computing System warranty, Cisco offers the Cisco Unified Computing Warranty Plus Service. You can choose from several levels of advanced parts replacement coverage, including onsite parts replacement in as little as two hours. Warranty Plus provides remote access any time to Cisco support professionals who can determine if a return materials authorization (RMA) is required. You can choose a service listed in [Table 12](#).

Table 12 UCS Computing Warranty Plus Service

Product ID (PID)	On Site?	Description
CON-UCW2-B230-M2	No	UC Warranty Plus 8x5x4
CON-UCW3-B230-M2	No	UC Warranty Plus 24x7x4
CON-UCW4-B230-M2	No	UC Warranty Plus 24x7x2
CON-UCW5-B230-M2	Yes	UC Warranty Plus 8X5XNBD
CON-UCW6-B230-M2	Yes	UC Warranty Plus 8X5X4
CON-UCW7-B230-M2	Yes	UC Warranty Plus 24x7x4
CON-UCW8-B230-M2	Yes	UC Warranty Plus 24x7x2

Unified Computing Drive Retention Service

With the Cisco Unified Computing Drive Retention (UCDR) service, you can obtain a new disk drive in exchange for a faulty drive without returning the faulty drive. In exchange for a Cisco replacement drive, you provide a signed Certificate of Destruction (CoD) confirming that the drive has been removed from the system listed, is no longer in service, and has been destroyed.

Sophisticated data recovery techniques have made classified, proprietary, and confidential information vulnerable, even on malfunctioning disk drives. The UCDR service enables you to retain your drives and ensures that the sensitive data on those drives is not compromised, thereby reducing the risk of any potential liabilities. This service also enables you to comply with regulatory, local, and federal requirements.

If your company has a need to control confidential, classified, sensitive, or proprietary data, you might want to consider one of the Drive Retention Services listed in [Table 13](#).



NOTE: Cisco does not offer a certified drive destruction service as part of this service.

Table 13 Drive Retention Service Options

Service Description	Service Program Name	Service Level GSP	Service Level	Product ID (PID)
UCS Mission Critical Support Service With Drive Retention	UC CRIT DR	UCMD7	24x7x4 Onsite	CON-UCMD7-B230-M2
		UCMD8	24x7x2 Onsite	CON-UCMD8-B230-M2
UCS Support Service With Drive Retention	UC SUPP DR	UCSD1	8x5xNBD	CON-UCSD1-B230-M2
		UCSD2	8x5x4	CON-UCSD2-B230-M2
		UCSD3	24x7x4	CON-UCSD3-B230-M2
		UCSD4	24x7x2	CON-UCSD4-B230-M2
		UCSD5	8x5xNBD Onsite	CON-UCSD5-B230-M2
		UCSD6	8x5x4 Onsite	CON-UCSD6-B230-M2
		UCSD7	24x7x4 Onsite	CON-UCSD7-B230-M2
		UCSD8	24x7x2 Onsite	CON-UCSD8-B230-M2

Table 13 Drive Retention Service Options (*continued*)

Service Description	Service Program Name	Service Level GSP	Service Level	Product ID (PID)
UCS Warranty Plus With Drive Retention	UC PLUS DR	UCWD2	8x5x4	CON-UCWD2-B230-M2
		UCWD3	24x7x4	CON-UCWD3-B230-M2
		UCWD4	24x7x2	CON-UCWD4-B230-M2
		UCWD5	8x5xNBD Onsite	CON-UCWD5-B230-M2
		UCWD6	8x5x4 Onsite	CON-UCWD6-B230-M2
		UCWD7	24x7x4 Onsite	CON-UCWD7-B230-M2
		UCWD8	24x7x2 Onsite	CON-UCWD8-B230-M2

For more service and support information, see the following URL:

http://www.cisco.com/en/US/services/ps2961/ps10312/ps10321/Cisco_UC_Warranty_Support_DS.pdf

For a complete listing of available services for Cisco Unified Computing System, see this URL:

http://www.cisco.com/en/US/products/ps10312/serv_group_home.html

ORDER OPTIONAL KVM CABLE

The KVM cable provides a connection into the server, providing a DB9 serial connector, a VGA connector for a monitor, and dual USB 2.0 ports for a keyboard and mouse. With this cable, you can create a direct connection to the operating system and the BIOS running on the server.

The KVM cable ordering information is listed in [Table 14](#).

Table 14 KVM Cable

Product ID (PID)	PID Description
37-1016-01	KVM Cable

Figure 4 KVM Cable

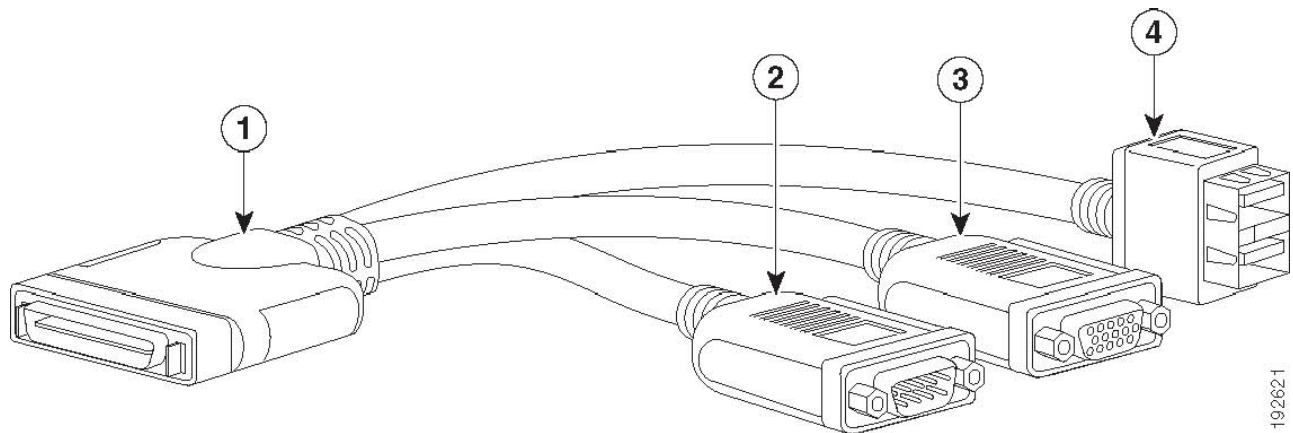

1	Connector (to server front panel)	3	VGA connector (for a monitor)
2	DB-9 serial connector	4	Two-port USB 2.0 connector (for a mouse and keyboard)

SUPPLEMENTAL MATERIAL

Motherboard

A top view of the B230 M2 motherboard is shown in *Figure 5*.

Figure 5 B230 M2 Motherboard

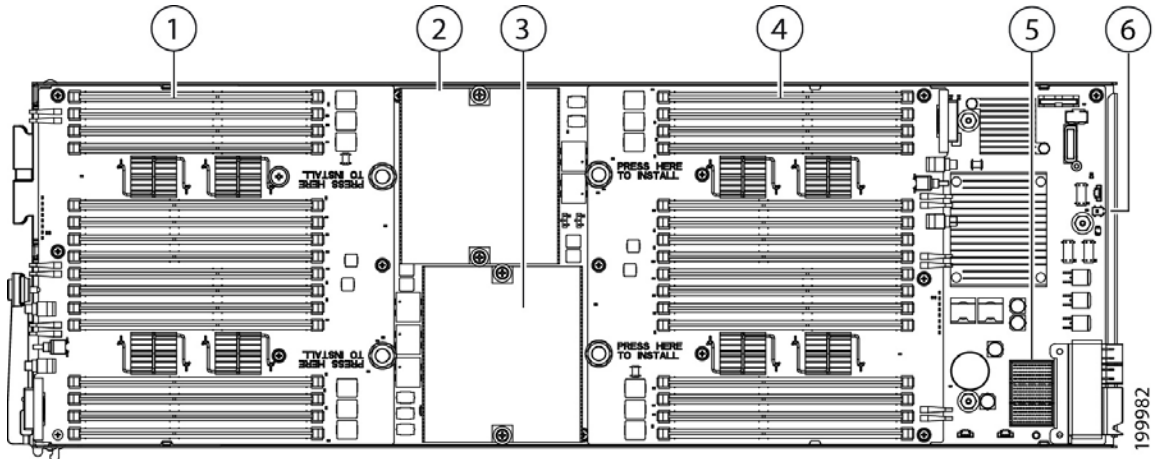

1	DIMM slots	4	DIMM slots
2	CPU 1 and heat sink	5	Mezzanine adapter card connector
3	CPU 2 and heat sink	6	Diagnostic button

DIMM and CPU Layout

Each CPU controls four memory channels, as shown in *Figure 6*.

Figure 6 B230 M2 Memory Organization

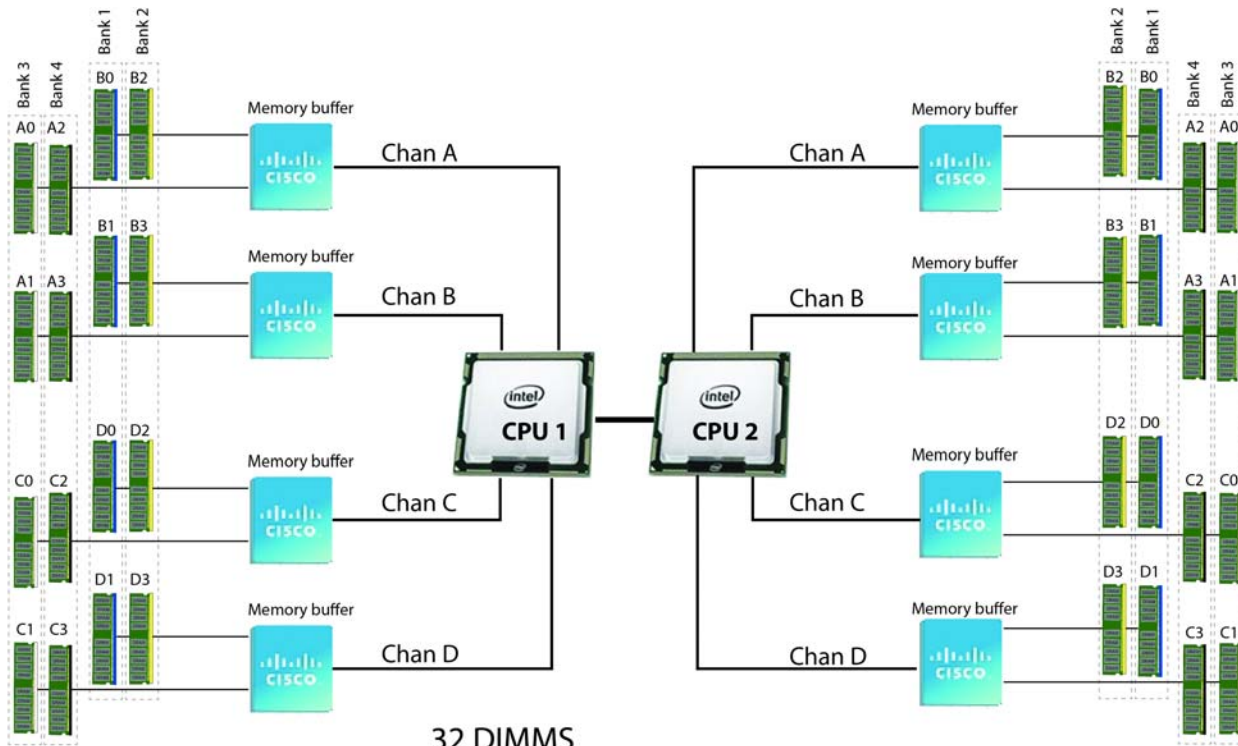

32 DIMMS
 512 GB maximum memory
 4 memory channels per CPU,
 up to 4 DIMMs per channel

- CPU1: Channels A, B, C, and D
 - Bank 1 - B0, B1; D0, D1 (blue DIMM slots)
 - Bank 2 - B2, B3; D2, D3 (yellow DIMM slots)
 - Bank 3 - A0, A1; C0, C1 (white DIMM slots)
 - Bank 4 - A2, A3; C2, C3 (black DIMM slots)
- CPU2: Channels A, B, C, and D
 - Bank 1 - B0, B1; D0, D1 (blue DIMM slots)
 - Bank 2 - B2, B3; D2, D3 (yellow DIMM slots)
 - Bank 3 - A0, A1; C0, C1 (white DIMM slots)
 - Bank 4 - A2, A3; C2, C3 (black DIMM slots)

The DIMM and CPU physical layout is shown in *Figure 7*. CPU 1 is located on the upper half of the board and controls the upper DIMMs. CPU 2 is located on the lower half of the board and controls the lower DIMMs.

Figure 7 DIMM and CPU Layout

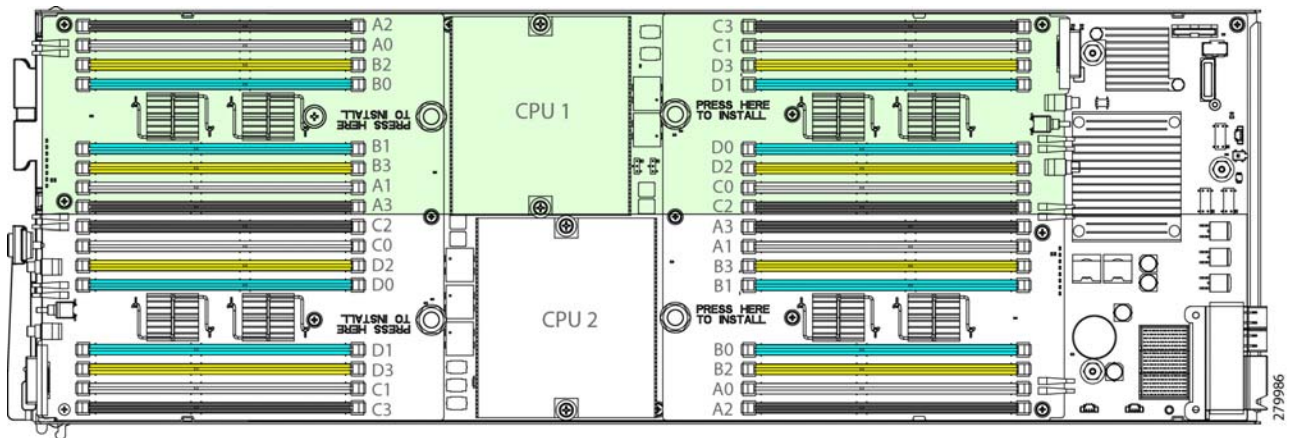

NOTE: DIMMs installed in slots for an absent CPU are not recognized.

Memory Population Recommendations

Table 15 shows the preferred order for installing upgrade DIMMs, and while other configurations may work, if problems arise, moving them to the preferred arrangement should help. Note that the bank installation order is Bank 1, Bank 3, Bank 2, Bank 4.

Table 15 Preferred DIMM Population Order

DIMMs per CPU	Numbered Slots ¹
2 (blue)	(B0, B1)
4 (blue)	(B0, B1) - (D0, D1)
8 (blue, white)	(B0, B1) - (D0, D1) - (A0, A1) - (C0, C1)
16 (blue, white, yellow, black)	(B0, B1) - (D0, D1) - (A0, A1) - (C0, C1) - (B2, B3) - (D2, D3) - (A2, A3) - (C2, C3)

Notes . . .

1. The slots inside the parentheses are electrically paired with each other, and should be populated with identically matched DIMMs that were ordered as a pair. Do not swap a paired DIMM with a DIMM that is not identical in manufacturer part number.

When considering the memory configuration of your server, you should observe the following:

- DIMMs within the blade server can be of a different size.
- Your selected CPU(s) can have some effect on performance. If two CPUs are used, they must both be of the same type.
- Performance degradation can result from the following:
 - Mixing DIMM sizes and densities within a pair is not allowed and both DIMMs in the pair will be logically removed from the memory array
 - Unevenly populating DIMMs between CPUs

Table 16 gives the recommended memory configurations for the B230 M2 blade server.

Table 16 Recommended B230 M2 Memory Configurations

Total System Memory Size (GB)	DIMM Pairs per CPU	DIMMs in Banks 1 and 3 1 = B0,B1,D0,D1 3 = A0,A1,C0,C1	DIMMs in Banks 2 and 4 2 = B2,B3,D2,D3 4 = A2,A3,C2,C3	Total Memory Size per CPU	Highest DIMM Operation Speed	Total DIMMs in System	Relative Performance
16	1 pair (B0, B1)	2 x 4 GB	0	8 GB	1066 MHz	4	Poor approx 0.25 x peak bandwidth
32		2 x 8 GB	0	16 GB	1066 MHz	4	
64		2 x 16 GB	0	32 GB	1066 MHz	4	
32	2 identical pairs (B0, B1) (D0, D1)	4 x 4 GB	0	16 GB	1066 MHz	8	Average approx 0.50 x peak bandwidth
64		4 x 8 GB	0	32 GB	1066 MHz	8	
128		4 x 16 GB	0	64 GB	1066 MHz	8	
64	4 identical pairs (B0, B1) (D0, D1) (A0, A1) (C0, C1)	8 x 4 GB	0	32 GB	1066 MHz	16	Good approx 0.94 x peak bandwidth
128		8 x 8 GB	0	64 GB	1066 MHz	16	
256		8 x 16 GB	0	128 GB	1066 MHz	16	
128	8 identical pairs (system fully populated)	8 x 4 GB	8 x 4 GB	64 GB	1066 MHz	32	Best approx 1.0 x peak bandwidth
256		8 x 8 GB	8 x 8 GB	128 GB	1066 MHz	32	
512		8 x 16 GB	8 x 16 GB	256 GB	1066 MHz	32	
320	8 mixed pairs (system fully populated)	8 x 16 GB	8 x 4 GB	160 GB	1066 MHz	32	Best approx 1.0 x peak bandwidth
384		8 x 16 GB	8 x 8 GB	192 GB	1066 MHz	32	
192		8 x 8 GB	8 x 4 GB	96 GB	1066 MHz	32	

TECHNICAL SPECIFICATIONS

Dimensions and Weight

Table 17 UCS B200 M2 Dimensions and Weight¹

Parameter	Value
Height	1.95 in. (50 mm)
Width	8.00 in. (203 mm)
Depth	24.4 in. (620 mm)
Weight	18.0 lbs (8.16 kg)*

Notes . . .

1. The system weight given here is an estimate for a fully configured system and will vary depending on the number of CPUs, memory DIMMs, and other optional items.

Power Specifications

For configuration-specific power specifications, use the Cisco UCS Power Calculator at:
http://www.cisco.com/assets/cdc_content_elements/flash/dataCenter/cisco_ucs_power_calculator/.



Americas Headquarters
Cisco Systems, Inc.
San Jose, CA

Asia Pacific Headquarters
Cisco Systems (USA) Pte. Ltd.
Singapore

Europe Headquarters
Cisco Systems International BV Amsterdam,
The Netherlands

Cisco has more than 200 offices worldwide. Addresses, phone numbers, and fax numbers are listed on the Cisco Website at www.cisco.com/go/offices.

Cisco and the Cisco Logo are trademarks of Cisco Systems, Inc. and/or its affiliates in the U.S. and other countries. A listing of Cisco's trademarks can be found at www.cisco.com/go/trademarks. Third party trademarks mentioned are the property of their respective owners. The use of the word partner does not imply a partnership relationship between Cisco and any other company. (1005R)