



CHAPTER 11

Configuring Your WLAN Radio Environment

The following topics provide information about the WLSE radio environment:

- [WLSE Radio Management, page 11-1](#)
- [Enabling and Disabling Radio Management Features, page 11-4](#)
- [Configuring Your Network for Radio Management, page 11-5](#)
- [Understanding Radio Management, page 11-7](#)
- [Understanding Frequency and Transmit Power Planning, page 11-14](#)
- [Collecting Radio Location Data, page 11-14](#)

WLSE Radio Management

The WLSE simplifies the deployment, expansion, and day-to-day management of your WLAN radio environment. Using radio management, intrusion detection, and site management features, you can:

- Automatically configure network-wide radio parameters during initial deployment and network expansion.
- Detect all neighboring APs and produce path loss data used for rogue location estimations, radio parameter generation, and coverage display data, generate additional data to help provide optimal coverage for the radio parameter generator, and provide configurations for APs based on measurement data collected from client walkabouts and AP radio scans.
- Continuously monitor the radio environment, adjust APs to cover potential areas of lost coverage, alert the WLAN administrator to radio network changes, and feed frame monitoring information to a third-party server for further analysis.
- Detect and report network intrusions, such as rogue APs, interference, ad-hoc networks, excessive management frame transmissions, unregistered clients, and authentication and protection attacks.
- Access a graphical view of the access points (APs) on each floor of your building(s) and view the relative location of unknown or rogue APs.

To set up and manage your WLAN radio environment, use the features provided by the Radio Manager, Sites, and the Intrusion Detection System:

Figure 11-1 Radio Management Setup Overview

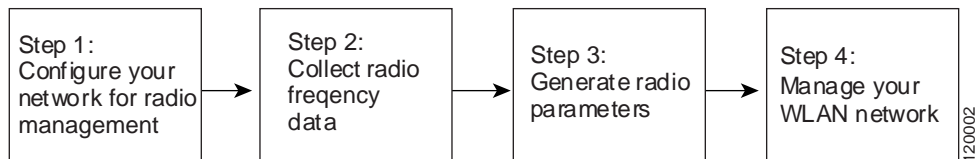

Step 1: Configure your network for radio management

All the device information shown under the Radio Manager, Sites, and Intrusion Detection Services tabs is polled from the managed devices in your network. The WLSE polls and receives aggregated data from WDS devices and provides intelligent processing of this data. The WLSE can manage multiple subnets, so it can receive radio frequency data from many WDS devices.

The WLSE must register with each WDS in each managed AP subnet to receive radio frequency data. If the WLSE is not registered, *none of the Radio Manager, Sites, or Intrusion Detection System functions will work.*



Note The WLSE supports up to 70 WDS devices.

In addition, if Radio Management has been disabled, none of the Radio Manager functions will work. You must enable Radio Management to access the Radio Manager features (see [Enabling and Disabling Radio Management Features, page 11-4](#)).

For more information about preparing your network to manage radio devices, see:

- [What is WDS and Why Do I Need It?, page 11-8](#)
- [Configuring Your Network for Radio Management, page 11-5](#)
- [Verifying Radio Management Capability, page 13-27](#)
- The *Installation and Configuration Guide for the CiscoWorks Wireless LAN Solution Engine*. For information about locating this document, see [Finding WLSE Documentation on Cisco.com, page 1-15](#).

Step 2: Collect radio location measurements.

After the access points have been configured for radio management, you can use selections under the Radio Manager and Sites tabs to gather radio location measurements. The WLSE uses these measurements to characterize the radio environment and determine the channels and power limits for each 802.11 Basic Service Set (BSS).

To collect this data, you can either:

- Run a wizard that walks you through the data collection process (see [Using the Location Manager Assisted Site Survey Wizard, page 13-17](#)).
- Run the data collection processes separately:
 - a. Run AP Radio Scan—see [Using AP Radio Scans to Collect RM Data, page 13-43](#)
 - b. Run Client Walkabout—see [Using Client Walkabouts to Collect RM Data, page 13-54](#)
 - c. Start Radio Monitoring—see [Using Radio Monitoring to Collect RM Data, page 12-1](#)

For more information about collecting and managing radio location measurements, see:

- [Collecting Radio Location Data, page 11-14](#)

- [Managing RM Data, page 13-81](#)

Step 3: Generate optimal radio parameters values for the APs.

You can use the selections under the Radio Manager or Sites tabs to recommend optimal radio transmit power, channel selection, and beacon interval (optional) for each AP, then apply these configuration settings.

To generate these parameters, you can either:

- Run a wizard that walks you through the parameter generation process
- Run the RM Assisted Configuration procedure

For more information about generating AP radio parameters, see [Generating Radio Parameters, page 13-66](#).

Step 4: Manage your WLAN network.

After you have configured your network for radio management, collected the radio location data, and generated the radio parameters, you are ready to manage your WLAN environment. You can:

- Use the Radio Manager to evaluate AP radio performance, adjust neighboring AP interfaces to cover potential areas of lost coverage, or use dedicated APs as sensors to feed information to a third-party server for further analysis (see [Managing Your WLAN Radio Environment, page 12-1](#)).
- Use a graphical view of the APs on each floor of your building(s) to display the predicted coverage of each AP (see [Managing Your WLAN Radio Environment by Sites, page 13-1](#)).
- Detect network intrusions such as rogue APs, ad-hoc networks, non-802.11 interference, and so on (see [Using the Intrusion Detection System, page 14-1](#)).

Related Topics

- [Configuring Your Network for Radio Management, page 11-5](#)
- [Enabling and Disabling Radio Management Features, page 11-4](#)
- [Understanding Radio Management, page 11-7](#)

Enabling and Disabling Radio Management Features

WLSE Radio Management includes three major groups of features: the Intrusion Detection System (IDS), the Radio Manager (Radio Mgr), and the Site planning features (Sites, including Location Manager). By default, these features are automatically enabled. However, customers that have large, distributed, or staged deployments of wireless solutions might only require the fault, performance, and configuration management features of WLSE and will want to disable Radio Management.

The following topics provided more information about disabling Radio Management:

- [Using the CLI Command, page 11-4](#)
- [Disabled Radio Management Related Faults, page 11-4](#)

Using the CLI Command

The following CLI command will enable or disable Radio Management and restart the WLSE:

```
radiomanager enable | disable
```

Enabling or disabling Radio Management causes the WLSE to reload. For more information about this command, see [Command Line Interface \(CLI\) Commands, radiomanager, page A-35](#).

Disabled Radio Management Related Faults

When Radio Management is disabled, no new Radio Management related faults are generated, and any Radio Management related faults that existed before the command was executed must be cleared manually. After the faults are manually cleared, they are not regenerated even if the fault condition still exists.

When Radio Management is disabled, the following faults are no longer generated:

- Ad-hoc detection (all)
- Auto re-site survey (all)
- General IDS settings (see **IDS > Manage IDS Settings**):
 - Unregistered Client
 - Excessive Frame Management
 - EAPOL Settings
- Inconsistent state fault
- Interference (all)
- Management frame protection (all)
- Non-IDS settings (see **Faults > Manage Fault Settings**):
 - Access Point/Bridge Policies > Registration Error
 - Radio 802.11x Policies > Dynamic Frequency Selection (DFS)
 - WDS > Authentication Failures
 - WDS > WLSE-WDS Link Status
- Rogue detection (all)

- Self healing (all)

Configuring Your Network for Radio Management

Before you can use the Radio Management features provided by WLSE, you must configure your network. If your network is not properly configured, *none of the Radio Manager, Sites, or Intrusion Detection System functions will work.*

If you are configuring APs or WLSM devices as WDS devices, you can use the Deployment Wizard (see [Using the Deployment Wizard, page 2-1](#)). The Deployment Wizard replaces many of the manual configuration procedures that are normally required to configure infrastructure access points and WDS devices and to configure the WLSE to discover and manage those devices.

Although you can use the Deployment Wizard to set up most APs, you must use the following manual procedure to configure an external ACS server for AP-WDS-WLSE authentication.



Note AP1250 with 11n radios is not supported for Radio Management

Procedure

- Step 1** Be sure that all APs are managed (discovered, inventoried, and managed—see [Device Discovery and Management, page 4-1](#)).
- Step 2** Configure one or more WDS devices (for more information about WDS, see [What is WDS and Why Do I Need It?, page 11-8](#)):
- **AP-WDS:** You can configure one or more APs in each AP subnet to run WDS. When multiple WDSs exist in the same subnet, one WDS becomes the active WDS and the other WDSs become backups. For more information about configuring AP-WDS devices, see the “Radio Management Setup—IOS Devices” chapter in *Configuring Devices for Management by the CiscoWorks Wireless LAN Solution Engine, 2.15*. For information about locating this document, see [Finding WLSE Documentation on Cisco.com, page 1-15](#).
 - **WLSM-WDS:** You can configure a Wireless LAN Services Module ([WLSM](#)) device to run WDS. A WLSM device is a module for the Cisco Catalyst 6500 Series switch that provides WDS to the wireless network. For information about configuring WLSM-WDS devices, see the WLSM device documentation.
- Step 3** Configure your devices for radio management.
- For information about radio management configuration procedures, see the “Radio Management Setup—IOS Devices” chapter in *Configuring Devices for Management by the CiscoWorks Wireless LAN Solution Engine, 2.15*.
- To verify that you have correctly configured the network for radio management, use the **Verify RM Capability** option under the Sites tab (see [Verifying Radio Management Capability, page 13-27](#)).
- Step 4** Enable LEAP authentication.



Note All APs must authenticate with a WDS using LEAP. This requirement is separate from the client’s authentication scheme—clients can use a non-LEAP security scheme, but the AP and WLSE must use LEAP to authenticate to the WDS.



Note A WDS can connect to Cisco's ACS v3.2 as the LEAP Authentication server. You can use the AP/WLSM's LEAP Local Authentication Server feature if the customer is not using LEAP for any purpose other than to fulfill the requirement on the WLSE/WDS/AP.



Note Do not set a session timeout on the ACS server that is less than 600 seconds. A session timeout of less than 600 seconds can disrupt Radio Manager operations.

For more information about enabling LEAP authentication, see the *Configuring Devices for Management by the CiscoWorks Wireless LAN Solution Engine, 2.15*. For information about locating this document, see [Finding WLSE Documentation on Cisco.com, page 1-15](#).

Step 5 Configure the WLCCP credentials (see [Enter WLCCP Credentials for Wireless Domain Services, page 4-14](#)).

Step 6 Verify that the active WDS appears under the device tree:

- a. Select **Reports > Device Center**.
- b. Open the **Wireless Domain Services** folder.
- c. Open the **Active WDS** folder.
- d. Select the device.
- e. Select **WDS Summary Report**.
- f. Verify that the **WLSE to WDS Authentication Status** column contains the string "KeysSetUpWithWDS" or "Authenticated".

You can also verify this setting by running the "show wlccp wnm status" command on the active WDS in enable mode. A typical output would look like this:

```
NMS-AP1200-1#show wlccp wnm status
WNM IP Address: 172.16.0.0 Status: SECURITY KEYS SETUP
```

where:

- 172.16.0.0 = IP address of WLSE
- Status = SECURITY KEYS SETUP. This indicates that the active WDS is properly authenticated with WLSE.

Step 7 Verify that the APs are managed and registered with WDS:

- a. Select **Reports > Device Center**.
- b. Open the **Wireless Domain Services** folder.
- c. Open the **Active WDS** folder.
- d. Select the device.
- e. Select **WDS Registered APs**. A list of all the APs that are registered with this WDS is displayed.

You can also verify this setting by running the "show wlccp wds ap" CLI command on the active WDS in enable mode.

Step 8 Configure the ACS server to support fast roaming and simultaneous logins.

For information about configuring the ACS server to support roaming and simultaneous logins, see the ACS server documentation. For other information about configuring the ACS server, see the “Setting Up an ACS Server” chapter in *Configuring Devices for Management by the CiscoWorks Wireless LAN Solution Engine, 2.15*. For information about locating these documents, see [Finding WLSE Documentation on Cisco.com, page 1-15](#).

Step 9 Configure the AAA server to allow multiple jobs.

For information about configuring the AAA server to multiple logins, see the AAA server documentation. For other information about configuring the AAA server, see the “Setting Up an ACS Server” chapter in *Configuring Devices for Management by the CiscoWorks Wireless LAN Solution Engine, 2.15*. These documents are also located on Cisco.com.

Step 10 Now you are ready to collect radio location data (see [Collecting Radio Location Data, page 11-14](#)).

Related Topics

- [Enabling and Disabling Radio Management Features, page 11-4](#)
- [Understanding Radio Management, page 11-7](#)

Understanding Radio Management

The radio management environment provided by WLSE consists of:

- *Procedures* that gather data about the radio environment.
- The radio frequency *database*, which contains radio data and parameters.
- *Features* that use the information in the database.

Figure 11-2 WLSE Radio Management Environment

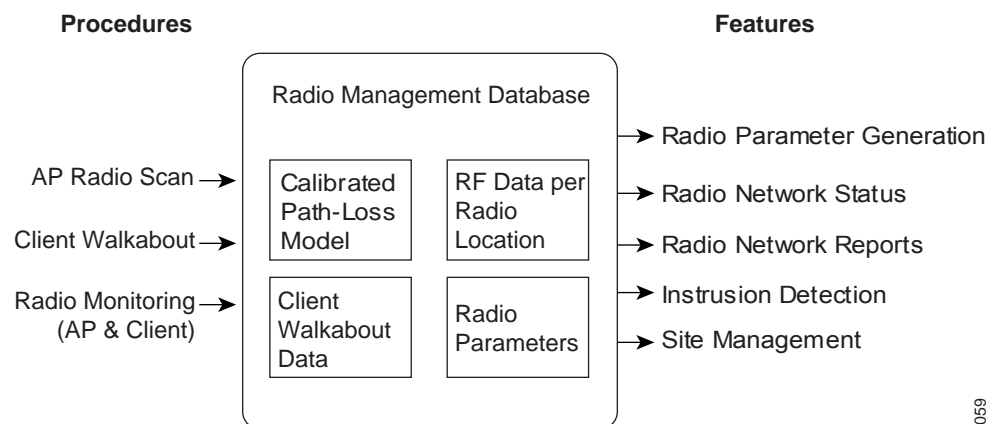

130059

The following topics describe how the WLSE implements radio management:

- [What is WDS and Why Do I Need It?, page 11-8](#)
- [Understanding Radio Performance—Coverage and Capacity, page 11-10](#)
- [Collecting Radio Location Data, page 11-14](#)

What is WDS and Why Do I Need It?

The critical software component in the network is a set of IOS features called the Wireless Domain Services (WDS). The following types of devices can supply the WDS:

- An access point configured for WDS
Each WDS access point supports one AP subnet. You can add additional WDS access points for redundancy. The priorities you set on the WDS access points determine which one is the active and which ones are backups.
- A Wireless LAN Services Module (WLSM)
Each WLSM supports multiple AP subnets, as long as all of the subnets are served by the switch on which the WLSM is installed.

The following topics describe these devices types:

- [Understanding WDS Access Points, page 11-8](#)
- [Understanding WLSM WDS Devices, page 11-9](#)

Understanding WDS Access Points

The WDS provides control path technologies that must be active on an AP in each AP subnet; a backup WDS can also be defined in each AP subnet. The WDS provides:

- Fast, secure layer-2 wireless client roaming—The WDS acts as an 802.1x authenticator for wireless clients within the layer-2 network.
- Radio Management (RM) data aggregation—The WLSE provides intelligent processing of aggregated data collected by the WDS access points from other wireless clients in the network. The WLSE can manage multiple subnets, so it can receive radio data from many APs running WDS.

There is no RM data aggregation without a WDS. Without a WDS, the communication between the access points and WLSE looks like this:

Figure 11-3 Basic Network Management Communications

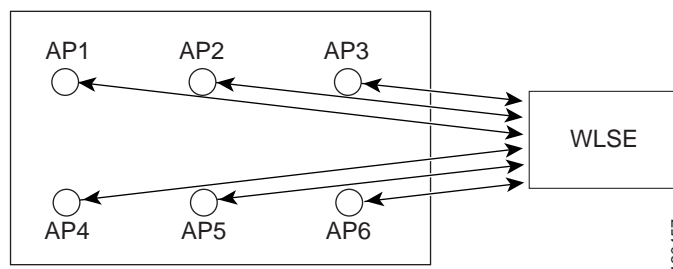

Using this approach, the WLSE can communicate with the APs using only these two methods:

- Primary: SNMP
- Secondary: CLI over telnet or SSH

Caution

The WLSE must register with the WDS in each managed AP subnet to receive Radio Manager data. If the WLSE is not registered, *none of the Radio Manager functions will work.*

After you configure the network for Radio Management tasks (see [Configuring Your Network for Radio Management, page 11-5](#)), the WLSE communicates all Radio Management activities with one or more WDS APs instead of all APs in the network. Each WDS AP collects data from other wireless clients in the network and sends this aggregated data to the WLSE.

Figure 11-4 Additional Radio Management Communications

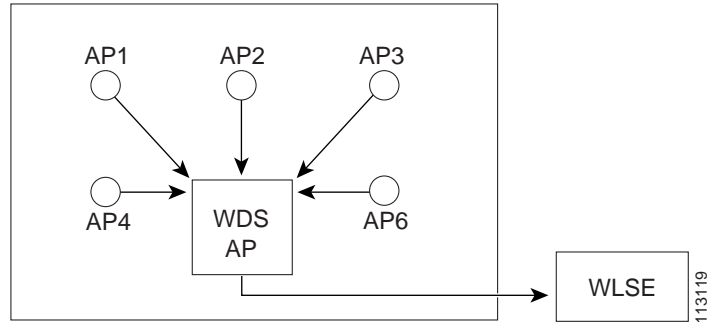

Understanding WLSM WDS Devices

A Wireless LAN Services Module ([WLSM](#)) device is a module for the Cisco Catalyst 6500 Series switch that provides WDS to the wireless network. Each WLSM supports multiple AP subnets, as long as all of the subnets are served by the switch on which the WLSM is installed.

You can add a second WLSM to serve as a standby. The WLSE authenticates with both the HSRP active and HSRP standby WLSM devices (WLSM uses HSRP to handle redundancies). In the reports, both WLSM devices (HSRP active and HSRP standby) will appear as active WDSs.

If the HSRP active WLSM goes down, the HSRP standby WLSM will communicate with the AP subnets (see [Figure 11-5](#)).

Figure 11-5 WLSE-WLSM Communications

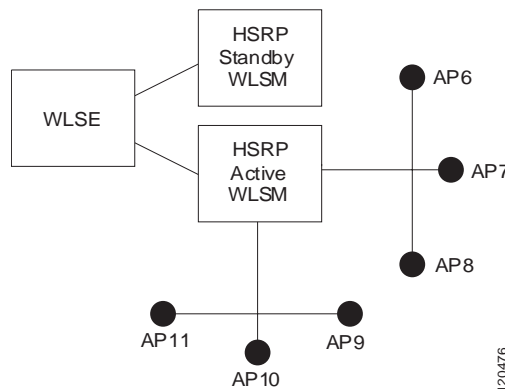

[Figure 11-6](#) illustrates a network that uses both AP and WLSM WDS devices to manage the access points in the network. In this example, additional access points have been identified as backup AP-WDS devices (AP1 and AP4), and an additional HSRP-based WLSM-WDS device has been added to as a standby for the active WLSM-WDS.

Figure 11-6 Sample Network Using AP-WDS and WLSM-WDS Devices

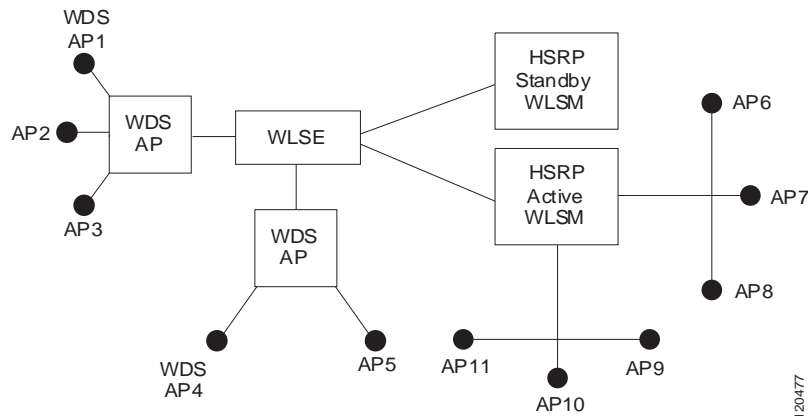

Understanding Radio Performance—Coverage and Capacity

The Radio Manager:

- Quantifies the performance within a region

Each region is defined by the rough degree of contention and packet collisions experienced by clients in the region due to traffic outside of the BSS.

The inter-BSS contention and collision translates into performance degradation, which the Radio Manager estimates for all potential clients within the region. Contention and collisions from managed APs *and* rogue and friendly APs are used in the performance evaluation.



Note All relevant APs are used in the performance evaluation regardless of building or floor placement.

- Takes the region sizes into account to assure coverage over the region

The types and sizes of performance regions determine the expected maximum, minimum, and average performance of a particular domain.

AP/Client Relationships

The Radio Manager acquires knowledge of the WLAN radio environment from measurements obtained from Cisco APs and Cisco clients. [Figure 11-7](#) illustrates the relationships between three APs and their clients.

Figure 11-7 AP/Client Relationships

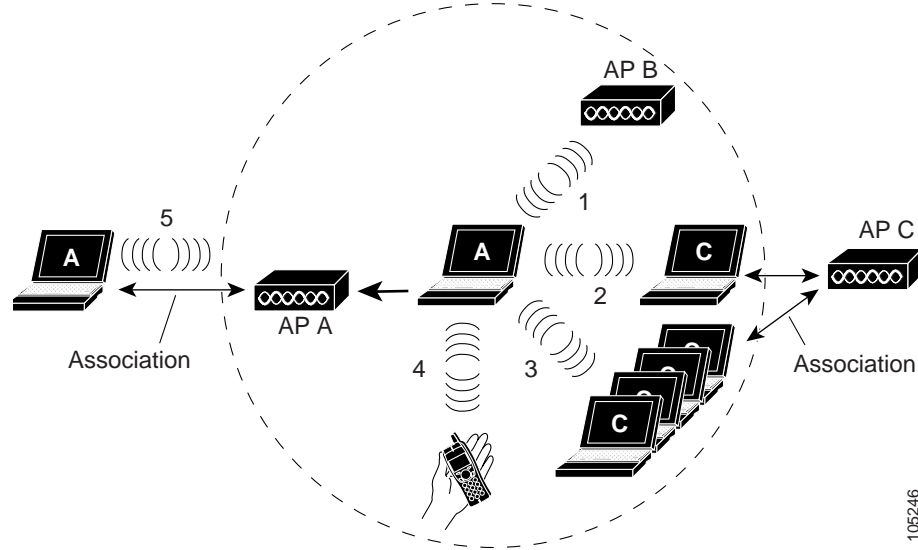

In this example, the measuring client and one other client are associated with AP A, but neither client detects the other AP's signal. AP B is close enough to be detected by the measuring client, and AP C is out of range, but the measuring client does detect some of AP C's associated clients. [Table 11-1](#) describes these relationships in more detail.

Table 11-1 AP/Client Relationships

Item	Description
1	The measuring client identifies access point B as a source of 802.11 contention.
2	The measuring client detects contention from a client in another BSS and identifies access point C as the BSS access point.
3	The measuring client reports significant contention due to clients in another BSS. Access point C is identified as the BSS access point.
4	The measuring client indicates intermittent non-802.11 interference and describes the statistics of its received strength.
5	The measuring client identifies another client in its BSS that appears to be hidden from it.

Radio Performance Regions

Radio performance regions within a BSS depend on the placement and transmit power of other co-channel APs. The transmit power of a BSS defines a set of RF reception rings around its AP (see [Figure 11-8](#)).

Figure 11-8 RF Reception Rings

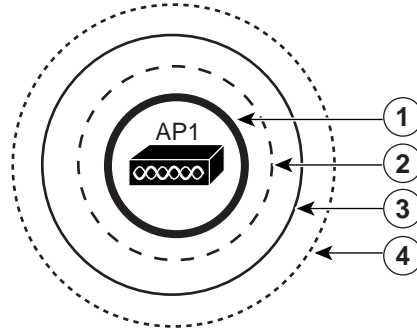

105883

1	Planned BSS coverage	3	Uplink may be decodable
2	Downlink RF influence	4	Uplink RF influence

Two rings correspond to the downlink:

- The **planned BSS coverage ring** (1) corresponds to the area in which clients can reliably receive the downlink signal.
- The **downlink RF influence ring** (2) corresponds to the area in which reception is difficult, but the downlink signal may still contend or collide with a downlink from another AP on the same channel.

Two similar rings correspond with areas of reception and the RF influence emanating from a client positioned at the edge of the BSS coverage ring. The significant ring, the **uplink RF influence ring** (4), corresponds to the signal that originates from a client sending packets up to its AP.

Uplink Contention Regions

In Figure 11-9, AP1 and AP2 share the same channel. AP2 is examined as the BSS of interest, while AP1 is the cochannel neighbor. The highlighted performance region corresponds with an area in which BSS2 clients must contend with traffic from BSS1. The source of contention is shown as a set of clients in BSS1 near the edge of their planned coverage ring. This is known as uplink contention because it delays uplink traffic from clients to their AP.

Figure 11-9 Sample Performance Region

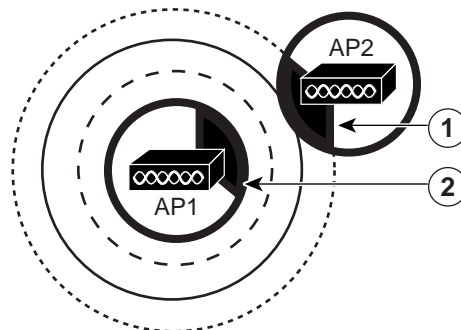

105884

1	BSS2 performance region: AP2 clients that experience contention from AP1's clients
2	Source of contention: AP1 clients that cause the contention.

If AP2 has neighbors sharing the same channel on all sides, then similar uplink contention regions are defined in the direction of each neighboring AP. If any of these neighbors is closer than the one shown in [Figure 11-9](#) or uses a higher power limit, then the uplink contention region is larger than shown in the figure. If clients of the neighboring BSSs are close enough to be detected by AP2, then AP2 experiences downlink contention due to the clients' traffic.

The BSS may also contain regions in which a client receives traffic that has collided with packets from another station. This occurs when the intended source and interfering source do not detect each other. This happens when:

- Stations in the same BSS are hidden from each other.
This situation can be remedied by blocking out time for an access point using RTS/CTS (request-to-send, clear-to-send) commands.
- A client in a neighboring BSS is within range of the client of interest but is not detected by the latter client's AP.
This situation is an inter-BSS interference problem that could exist in any dense WLAN and *cannot* be remedied with RTS/CTS. One goal of the Radio Manager is to minimize this occurrence with good radio configurations.

Understanding Multiple BSSIDs

The Base Service Set Identifier (BSSID) is typically the MAC address of the radio. WLSE also supports multiple BSSIDs (MBSSID) on a single radio (AP). MBSSIDs address several issues:

- Passive client scanning support for multiple SSIDs
- Multiple unencrypted multicast streams
- Segregation of unencrypted and encrypted broadcast streams
- Encrypted multicast streams to not cause decrypt errors at the client
- Support for existing clients (no changes allowed on the client)

To a *client*, an MBSSID AP appears to be several distinct co-located APs. An MBSSID AP transmits a beacon for each BSSID/SSID, which makes all of the SSIDs visible for passive scanning. The distinct VLAN multicast streams are easily separated using the BSSID, which allows multiple unencrypted multicast streams and eliminates the decryption errors that occur with encryption separation.

To the *WLSE*, the MBSSID AP appears to be one AP. Each radio that is configured with MBSSID will appear as one radio with multiple VLANs, and each distinct MAC address associated with the VLAN is considered a synonym of the real radio's MAC address.

Support for multiple BSSIDs does not imply full virtual AP capability and functionality. For example:

- All BSSIDs are synchronized to the same clock.
- All BSSIDs have the same transmit power.
- All BSSIDs use the same set of transmit data rates.
- The MAC address allocation is dynamically assigned by the radio.

Understanding Frequency and Transmit Power Planning

The Radio Parameter Generation algorithm in WLSE gives you a near-optimal frequency and power plan for managed APs. However at first look, the WLSE-recommended plan might be dramatically different from what you expect. If you have an understanding of 2G cellular technology, particularly GSM, it's important to know that the intuitive heuristics developed from 2G cellular telephony are misleading for WLANs.

In traditional 2G deployments, you design your power plan by making sure adjacent and nearby cells are on differing channels.

In 802.11 WLAN, the closest distance between two co-channel APs is less important than the total number of interfering APs in the entire coverage area.

There are significant differences in 2G and 802.11 WLANs:

- In 2G cellular telephony, devices in each cell transmit without regard to who is transmitting in other cells. Communication is reliable as long as the desired power is sufficiently above the total interference power from all other devices on the same channel. A frequency plan with adjacent co-channel APs is fatally poor.
- WLANs have much smaller cells than 2G systems and can achieve much higher per-user data rates. Instead of transmitting without regard to transmissions in other cells, 802.11 WLAN devices determine if the shared wireless medium is quiet and then transmit only when it is so. WLANs must minimize the number of interfering devices that can detect each other, *not* the total interference power.
- In 2G technology, the total interference *power* must be kept small by keeping co-channel devices far away from each other.
- In 802.11 WLAN systems, the total number of interfering *devices*, especially co-channel AP devices, must be kept small. In WLANs, a frequency plan that allows a few adjacent co-channel APs in exchange for making more co-channel APs completely undetectable is a better plan. *The closest distance between two co-channel APs is less important than the total number of interfering APs.*
- WLAN deployments cover multiple floors; in 2G cellular telephony, you cover the ground. In WLANs, you might be covering floors in 3 dimensions so you must take into consideration the signals from other floors and other buildings.

Collecting Radio Location Data

Radio location measurements characterize the radio environment and provide the information other Radio Manager features require to determine the channels and power limits for each Basic Service Set (BSS). To gather these measurements:

1. **Perform an AP Radio Scan.** The AP Radio Scan procedure detects all neighboring access points and produces path loss data used for rogue location estimations, radio parameter generation data, and coverage display data.

**Note**

If you do not run AP Radio Scan, the Coverage Display under the Sites tab will be computed using the default pass loss model. Because no path loss measurement data has been collected, the coverage views could be distorted.

2. **Perform a Client Walkabout** (optional, but recommended—see [Using Client Walkabouts to Collect RM Data, page 13-54](#)). The additional data generated by a client walkabout helps provide optimal coverage for the radio parameter generator.

If you do not perform a client walkabout, you *must* enter a floor plan that includes the distances between APs (see [Adding Floors to Location Manager, page 13-9](#)).

3. **Enable Radio Monitoring.** Radio Monitoring (see [Using Radio Monitoring to Collect RM Data, page 12-1](#)) periodically gathers RF statistics, identifies specific signal sources, and is your primary means of detecting rogue access points.



Note If you never enable Radio Monitoring or run AP Radio Scan, no unknown radios (rogue or friendly) will be detected. If you run AP Radio Scan but do not enable Radio Monitoring, some unknown radios will be detected, but not as many as would be detected if Radio Monitoring was running. Self healing also relies on the data generated by Radio Monitoring and AP Radio Scan.

You can also use the Assisted Site Survey wizard, which is part of Sites, to walk you through the process of determining the optimal radio transmit power and channel selection. This wizard interface steps you through AP radio scan, client walkabout, and radio parameter generation (see [Using the Location Manager Assisted Site Survey Wizard, page 13-17](#)).

Related Topics

- [Configuring Your Network for Radio Management, page 11-5](#)
 - [Viewing Current Path Loss Results, page 10-17](#)
 - [Viewing Historical Path Loss Results, page 10-19](#)
 - [Viewing Current Channel Load Results, page 10-19](#)
 - [Viewing Historical Channel Load Results, page 10-21](#)
 - [Managing RM Data, page 13-81](#)
 - [Understanding Radio Management, page 11-7](#)
-

