



Nortel Meridian 1/PBXLink Integration Guide for Cisco Unity 5.0

Revised November 26, 2007

This document provides instructions for integrating the Nortel Meridian/PBXLink phone system with Cisco Unity.

Integration Tasks

Before doing the following tasks to integrate Cisco Unity with the Nortel Meridian/PBXLink phone system, confirm that the Cisco Unity server is ready for the integration by completing the applicable tasks in the applicable Cisco Unity installation guide.

The following task list describes the process for creating the integration.

Task List to Create the Integration

Use the following task list to set up a new integration with the Nortel Meridian/PBXLink phone system. If you are installing a new Cisco Unity server by using the applicable Cisco Unity installation guide, you may have already completed some of the following tasks.

1. Review the system and equipment requirements to confirm that all phone system and Cisco Unity server requirements have been met. See the [“Requirements” section on page 2](#).
2. Plan how the voice messaging ports will be used by Cisco Unity. See the [“Planning How the Voice Messaging Ports Will Be Used by Cisco Unity” section on page 7](#).
3. Program the Nortel Meridian/PBXLink phone system and extensions. See the [“Programming the Nortel Meridian/PBXLink Phone System” section on page 9](#).
4. Install and configure the PBXLink box. See the [“Setting up the PBXLink Box” section on page 13](#).
5. Create the integration. See the [“Creating a New Integration with the Nortel Meridian/PBXLink Phone System” section on page 17](#).
6. Test the integration. See the [“Testing the Integration” section on page 21](#).



Americas Headquarters:
Cisco Systems, Inc., 170 West Tasman Drive, San Jose, CA 95134-1706 USA

© 2007 Cisco Systems, Inc. All rights reserved.

- If you have a secondary server for Cisco Unity failover, integrate the secondary server. See the [“Integrating a Secondary Server for Cisco Unity Failover”](#) section on page 25.

Requirements

The Nortel Meridian/PBXLink integration supports configurations of the following components:

Phone System

- Nortel Meridian 1 with the following software option packages installed:

Table 1 Required Option Packages

Option Package	Package Number
EES	10
MSB	17
DDSP	19
MWC	46
DSET	88
CPND	95
ARIE	170

- One or more digital lines that are compatible with the M2616 digital phone connected to the PBX ports on the PBXLink box.
- For each voice messaging port, one analog port connected to the voice cards in the Cisco Unity server.
- The SMDI port in the PBXLink box connected to a serial port (COM1 is the default) on the Cisco Unity server with an RS-232 serial cable. If multiple PBXLink boxes are installed, the SMDI port of the last PBXLink box is connected to the Management port of the first PBXLink box with an RS-232 serial cable. The SMDI port of the first PBXLink box is connected to a serial port (COM1 is the default) on the Cisco Unity server with another RS-232 serial cable. Make sure that the serial protocol parameters for the Management port of the first PBXLink box are set to the same values as the SMDI port.

We recommend that the serial cable have the following construction:

- A maximum of 50 feet (15.24 m) in length
- 24 AWG stranded conductors
- Low capacitance—for example, no more than 12 pF/ft (39.4 pF/m) between conductors
- At least 65 percent braided shield over aluminized polymer sleeve around conductors
- UL-recognized overall cable jacket insulation with low dielectric constant
- Braided shield fully terminated to and enclosed by a metal connector backshell
- Gold-plated connector contacts
- The phone system ready for the integration as described in the installation guide for the phone system.
- If you use ACD hunt groups, packages ACD-A and ACD-B.

Cisco Unity Server

- The applicable voice cards, installed. For details, refer to the “Supported Circuit-Switched Phone System Integrations” section in the applicable *Supported Hardware and Software, and Support Policies* at http://www.cisco.com/en/US/products/sw/voicesw/ps2237/prod_installation_guides_list.html.
- Cisco Unity installed and ready for the integration, as described in the applicable Cisco Unity installation guide at http://www.cisco.com/en/US/products/sw/voicesw/ps2237/prod_installation_guides_list.html.
- A license that enables the applicable number of voice messaging ports.
- An available serial port (COM1 is the default).

Integration Description

The Nortel Meridian/PBXLink integration uses one or more PBXLink boxes that each emulate up to two Nortel M2616 digital phones. The PBXLink is connected to the phone system with digital phone lines and connected to the Cisco Unity server with an RS-232 serial cable. The voice messaging lines from the phone system connect to the analog voice cards in the Cisco Unity server.

The PBXLink box receives the following call information from the phone system:

- The extension of the called party
- The extension of the calling party (for internal calls) or the phone number of the calling party (if it is an external call and the system uses caller ID)
- The reason for the forward (the extension is busy, does not answer, or is set to forward all calls)

The PBXLink box formats this information as a Simplified Message Desk Interface (SMDI) packet and sends the packet to Cisco Unity through the RS-232 serial cable.

Cisco Unity uses this information to answer the call appropriately. For example, a call forwarded to Cisco Unity is answered with the personal greeting of the subscriber. If the phone system routes the call to Cisco Unity without this information, Cisco Unity answers with the opening greeting.

The PBXLink box also activates or deactivates message waiting indicators (MWIs) after receiving a command from Cisco Unity.

For additional information on the PBXLink box, refer to the PBXLink documentation, which is available from the manufacturer.

Configuration for 24 or Fewer Ports

Nortel Meridian/PBXLink integrations with 24 or fewer ports can use one of the following configurations (others are possible):

- (Recommended) One PBXLink-48 box with Port A set for MWIs only and Port B set for calls only.
- Two PBXLink-24 boxes with Port A of one box set for MWIs only and Port A of the second box set for calls only.

**Caution**

The PBXLink box that handles MWIs must be the box that is directly connected to the Cisco Unity server. Otherwise, MWIs will not be set.

Configuration for 25 to 48 Ports

Nortel Meridian/PBXLink integrations with 25 to 48 ports can use the following configuration (others are possible):

- (Recommended) One PBXLink-48 box with Port A set for MWIs only and Port B set for calls only, and a single PBXLink-24 box with Port A set for calls only.



Caution The PBXLink box that handles MWIs must be the box that is directly connected to the Cisco Unity server. Otherwise, MWIs will not be set.

Configuration for 49 to 72 Ports

Nortel Meridian/PBXLink integrations with 49 to 72 ports can use one of the following configurations (others are possible):

- (Recommended) One PBXLink-48 box with Port A set for MWIs only and Port B set for calls only, and a second PBXLink-48 box with Ports A and B both set for calls only.
- Four PBXLink-24 boxes with Port A of the first set for MWIs only and Port A of the remaining three set for calls only.
- One PBXLink-24 box with Port A set for MWIs only, a second PBXLink-24 box with Port A set for calls only, and one PBXLink-48 box with Ports A and B both set for calls only.



Caution The PBXLink box that handles MWIs must be the box that is directly connected to the Cisco Unity server. Otherwise, MWIs will not be set.

Configuration for 73 to 96 Ports

Nortel Meridian/PBXLink integrations with 73 to 96 ports can use one of the following configurations (others are possible):

- (Recommended) A single PBXLink-24 box with Port A set for MWIs only, and two PBXLink-48 boxes with Ports A and B of both set for calls only.
- One PBXLink-48 box with Port A set for MWIs only and Port B set for calls only, and a second PBXLink-48 box with Ports A and B set for calls only, and a third PBXLink-48 box with Port A set for calls only and Port B disabled.
- Five PBXLink-24 boxes with Port A of the first set for MWIs only and Port A of the remaining four set for calls only.

It is not possible to use a single PBXLink-48 box with Port A set to both calls and MWIs and Port B set for calls only. In such a configuration, Port B is disabled.



Caution The PBXLink box that handles MWIs must be the box that is directly connected to the Cisco Unity server. Otherwise, MWIs will not be set.

Configuration for 97 to 120 Ports

Nortel Meridian/PBXLink integrations with 97 to 120 ports can use one of the following configurations (others are possible):

- (Recommended) A single PBXLink-48 box with Port A set for MWIs only and Port B set for calls only, and two PBXLink-48 boxes with Ports A and B of both set for calls only.

- One PBXLink-24 box with Port A set for MWIs only, two PBXLink-48 boxes with Ports A and B set for calls only, and a third PBXLink-48 box with Port A set for calls only and Port B disabled.
- Six PBXLink-24 boxes with Port A of the first set for MWIs only and Port A of the remaining five set for calls only.

It is not possible to use a single PBXLink-48 box with Port A set to both calls and MWIs and Port B set for calls only. In such a configuration, Port B is disabled.



Caution The PBXLink box that handles MWIs must be the box that is directly connected to the Cisco Unity server. Otherwise, MWIs will not be set.

Configuration for 121 to 144 Ports

Nortel Meridian/PBXLink integrations with 121 to 144 ports can use one of the following configurations (others are possible):

- (Recommended) A single PBXLink-24 box with Port A set for MWIs only, and three PBXLink-48 boxes with Ports A and B of all set for calls only.
- One PBXLink-48 box with Port A set for MWIs only and Port B set for calls only, and two PBXLink-48 boxes with Ports A and B set for calls only, and a fourth PBXLink-48 box with Port A set for calls only and Port B disabled.
- Seven PBXLink-24 boxes with Port A of the first set for MWIs only and Port A of the remaining six set for calls only.

It is not possible to use a single PBXLink-48 box with Port A set to both calls and MWIs and Port B set for calls only. In such a configuration, Port B is disabled.



Caution The PBXLink box that handles MWIs must be the box that is directly connected to the Cisco Unity server. Otherwise, MWIs will not be set.

PBXLink Box Connections

A single PBXLink box is connected to the phone system with a digital phone line and connected to the Cisco Unity server with an RS-232 serial cable. The voice messaging lines from the phone system connect to the analog voice cards in the Cisco Unity server. [Figure 1](#) shows the required connections.

Figure 1 Serial Connection Between a Single PBXLink Box and Cisco Unity

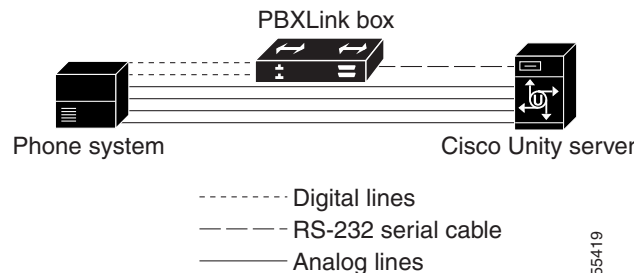

Multiple PBXLink boxes are connected to the Cisco Unity server by using an RS-232 cable to connect the SMDI port from the last PBXLink box to the Management port of the first PBXLink box. Another RS-232 cable is then used to connect the SMDI port of the first PBXLink box to the Cisco Unity server. The voice messaging lines from the phone system connect to the analog voice cards in the Cisco Unity server. [Figure 2](#) shows the required connections.

Figure 2 Serial Connections Between Multiple PBXLink Boxes and Cisco Unity

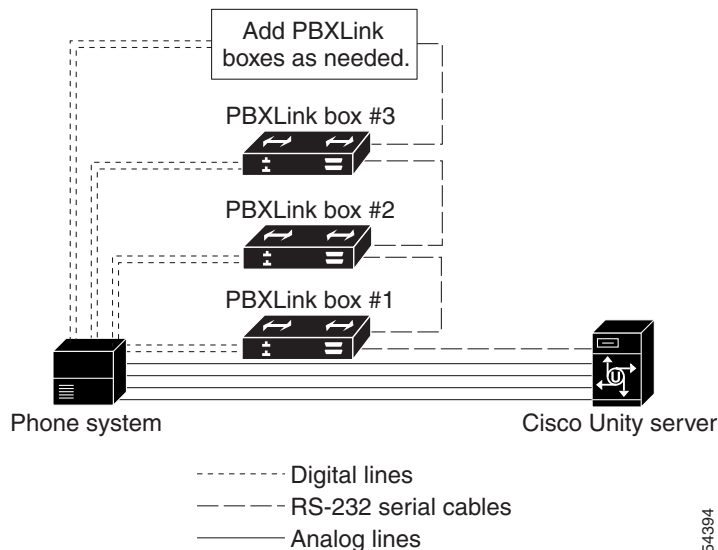

Integration Functionality

The Nortel Meridian/PBXLink integration with Cisco Unity provides the following integration features:

- Call forward to personal greeting
- Call forward to busy greeting
- Caller ID
- Easy message access (a subscriber can retrieve messages without entering an ID because Cisco Unity identifies the subscriber based on the extension from which the call originated; a password may be required)
- Identified subscriber messaging (Cisco Unity identifies the subscriber who leaves a message during a forwarded internal call, based on the extension from which the call originated)
- Message waiting indication (MWI)

Integrations with Multiple Phone Systems

Cisco Unity can be integrated with multiple phone systems at one time. For information on the maximum supported combinations and instructions for integrating Cisco Unity with multiple phone systems, refer to the applicable *Multiple Phone System Integration Guide* at http://www.cisco.com/en/US/products/sw/voicesw/ps2237/products_installation_and_configuration_guides_list.html.

Planning How the Voice Messaging Ports Will Be Used by Cisco Unity

Before programming the phone system, you need to plan how the voice messaging ports will be used by Cisco Unity. The following considerations will affect the programming for the phone system (for example, setting up the hunt group or call forwarding for the voice messaging ports):

- The number of voice messaging ports installed.
- The number of voice messaging ports that will answer calls.
- The number of voice messaging ports that will only dial out, for example, to send message notification, to set message waiting indicators (MWIs), to make AMIS deliveries, and to make telephone record and playback (TRAP) connections.

The following table describes the voice messaging port settings in Cisco Unity that can be set in UTIM, and that are displayed as read-only text on the System > Ports page of the Cisco Unity Administrator.

Table 2 **Settings for the Voice Messaging Ports**

Field	Considerations
Extension	Enter the extension for the port as assigned on the phone system.
Enabled	Check this check box to enable the port. The port is enabled during normal operation. Uncheck this check box to disable the port. When the port is disabled, calls to the port get a ringing tone but are not answered. Typically, the port is disabled only by the installer during testing.
Answer Calls	Check this check box to designate the port for answering calls. These calls can be incoming calls from unidentified callers or from subscribers.
Message Notification	Check this check box to designate the port for notifying subscribers of messages. Assign Message Notification to the least busy ports.
Dialout MWI <i>(not used by serial or SMDI integrations)</i>	Check this check box to designate the port for turning MWIs on and off. Assign Dialout MWI to the least busy ports.
AMIS Delivery <i>(available with the AMIS licensed feature only)</i>	Check this check box to designate the port for making outbound AMIS calls to deliver voice messages from Cisco Unity subscribers to users on another voice messaging system. Cisco Unity supports the Audio Messaging Interchange Specification (AMIS) protocol, which provides an analog mechanism for transferring voice messages between different voice messaging systems. This setting affects outbound AMIS calls only. All ports are used for incoming AMIS calls. Because the transmission of outgoing AMIS messages may tie up voice ports for long periods of time, you may want to adjust the schedule on the Network > AMIS > Schedule page so that outgoing AMIS calls are placed during closed hours or at times when Cisco Unity is not processing many calls.
TRAP Connection	Check this check box so that subscribers can use the phone as a recording and playback device in Cisco Unity web applications and e-mail clients. Assign TRAP Connection to the least busy ports.

The Number of Voice Messaging Ports to Install

The number of voice messaging ports to install depends on numerous factors, including:

- The number of calls Cisco Unity will answer when call traffic is at its peak.
- The expected length of each message that callers will record and that subscribers will listen to.
- The number of subscribers.
- The number of ports that will be set to dial out only.
- The number of calls made for message notification.
- The number of MWIs that will be activated when call traffic is at its peak.
- The number of AMIS delivery calls.
- The number of TRAP connections needed when call traffic is at its peak. (TRAP connections are used by Cisco Unity web applications to play back and record over the phone.)
- The number of calls that will use the automated attendant and call handlers when call traffic is at its peak.

It is best to install only the number of voice messaging ports that are needed so that system resources are not allocated to unused ports.

The Number of Voice Messaging Ports That Will Answer Calls

The calls that the voice messaging ports answer can be incoming calls from unidentified callers or from subscribers. Typically, the voice messaging ports that answer calls are the busiest.

You can set voice messaging ports to both answer calls and to dial out (for example, to send message notifications). However, when the voice messaging ports perform more than one function and are very active (for example, answering many calls), the other functions may be delayed until the voice messaging port is free (for example, message notifications cannot be sent until there are fewer calls to answer). For best performance, dedicate certain voice messaging ports for only answering incoming calls, and dedicate other ports for only dialing out. Separating these port functions eliminates the possibility of a collision, in which an incoming call arrives on a port at the same time that Cisco Unity takes the port off-hook to dial out.

The Number of Voice Messaging Ports That Will Only Dial Out, and Not Answer Calls

Ports that will only dial out and will not answer calls can do one or more of the following:

- Notify subscribers by phone, pager, or e-mail of messages that have arrived.
- Turn MWIs on and off for subscriber extensions.
- Make outbound AMIS calls to deliver voice messages from Cisco Unity subscribers to users on another voice messaging system. (This action is available only with the AMIS licensed feature.)
- Make a TRAP connection so that subscribers can use the phone as a recording and playback device in Cisco Unity web applications.

Typically, these voice messaging ports are the least busy ports.



Caution

In programming the phone system, do not send calls to voice messaging ports in Cisco Unity that cannot answer calls (voice messaging ports that are not set to Answer Calls). For example, if a voice messaging port is set only to Dialout MWI, do not send calls to it.

Preparing for Programming the Phone System

Record your decisions about the voice messaging ports to guide you in programming the phone system.

Programming the Nortel Meridian/PBXLink Phone System

If you use programming options other than those supplied in the following procedure, the performance of the integration may be affected.

Make sure that the phone system sends calls only to Cisco Unity voice ports that are set to Answer Calls on the System > Ports page in the Cisco Unity Administrator. Calls sent to a voice port not set to **Answer Calls** cannot be answered by Cisco Unity and may cause other problems.



Caution

In programming the phone system, do not send calls to voice messaging ports in Cisco Unity that cannot answer calls (voice messaging ports that are not set to Answer Calls). For example, if a voice messaging port is set only to Dialout MWI, do not send calls to it.

Do the following procedures as applicable.

To Program the Phone System

- Step 1** Assign extensions for the voice messaging ports.
- Step 2** Confirm that the software on the phone system is current by using overlay 22 to display options EES, MSB, DDSP, MWC, DSET, CPND, and ARIE. If any of these options is missing, contact your sales representative.
- Step 3** On overlay 15, set the following customer data block options.

Table 3 Customer Data Block Options

Option	Setting
REQ	CHG
TYPE	CDB
CUST	<customer number>
ATT_DATA	YES
AODN	<the pilot number for the automated attendant>
FTR_DATA	YES
OPT	CFO MCI IDP
EEST	NO
NIT_DATA	YES
NIT1	<the pilot number if night calls go to voice mail>
RDR_DATA	YES
FNAN (release 9 and earlier only)	FDN
FNAD	FDN
FNAT	FDN
FNAL	FDN

Table 3 Customer Data Block Options (continued)

Option	Setting
CFNA or CFN0	6
DFNA or DFN0	6
MDID	YES
NDID	YES
MWFB	YES
TIM_DATA	YES
LDTT	6

- Step 4** On overlay 95, set the following options to enable display of a four-letter code why the call was forwarded.

Table 4 Calling Party Display Options

Option	Setting
REQ	CHG
TYPE	CPND
CUST	<customer number>
RESN	YES
CFWD	CFWD
CFNA	CFNA
HUNT	HUNT
XFER	T
AAA	A

- Step 5** On overlay 10, set the following options to enable the analog voice messaging lines.

Table 5 Analog Voice Messaging Line Options

Option	Setting
CDEN	SD (if QPC60) DD (if QPC452) 4D (if QPC594)
CUST	<customer number>
DN	<the extension number for the port being set>
HUNT	<the next line after the port being set>
CLS	HTA FBD DTN XFA FND MWD LDTA

Step 6 On overlay 11, set the following options to enable the digital lines for the PBXLink box.

If you set up more than 24 voice messaging ports, we recommend that you balance the load among the PBXLink boxes. You can balance the load by enabling digital line keys for one PBXLink box to monitor odd-numbered ports (1, 3, 5, and so on), while enabling digital line keys on the other PBXLink box to monitor even-numbered ports (2, 4, 6, and so on). For details, see the [“To Set Up the Port LTNs for Two PBXLink Digital Ports”](#) section on page 15.

Table 6 *Digital Line Options*

Option	Setting
AOM	1
CLS	ADD HFD CNDA DNDA
HUNT	000
KEY 00 SCR	<the primary number for the digital line; any valid unused number>
KEY 12 DISP	
KEY 13 MIK	
KEY 14 MCK	
KEY 16 SCN	<the pilot number; or for an ACD hunt group, the first analog line number in the hunt group>
KEY 17 SCN	<the second analog line number after the extension for KEY 16>
.	<additional analog line numbers>
.	
.	
KEY 37 SCN	<the 22nd analog line number>
KEY 5 SCN	<the 23rd analog line number>
KEY 6 SCN	<the 24th analog line number>

Step 7 On each subscriber phone, program the phone to forward calls to the pilot number assigned to the voice messaging ports, based on one of the following Cisco Unity call transfer types.

Table 7 *Call Transfer Types*

Transfer Type	Usage
Release transfer (blind transfer)	Program the phone to forward calls to the pilot number when: <ul style="list-style-type: none"> • The extension is busy • The call is not answered
Supervised transfer	Program the phone to forward calls to the pilot number only when the call is not answered. Confirm that call forwarding is disabled when the extension is busy.

Do one of the following procedures, depending on the number of voice messaging ports in the Cisco Unity server. If Cisco Unity has more than 30 voice messaging ports, we recommend that you set up an ACD hunt group as described in the [“To Set Up an ACD Hunt Group for More Than 30 Ports”](#) section on page 12.

To Set Up a Hunt Group for Up to 30 Ports

-
- Step 1** Set up the first voice messaging port as the pilot number of the hunt group.
 - Step 2** Set the first voice messaging port to hunt to the second voice messaging port.
 - Step 3** Set the second voice messaging port to hunt to the third, then continue up to the 30th.
 - Step 4** Set the 30th voice messaging port to hunt to the first voice messaging port.

Table 8 Example of a 30-Port Hunt Group

Device	Setting	Destination
Port 1	HUNT	Port 2
Port 2	HUNT	Port 3
Port 3	HUNT	Port 4
.		<additional ports>
.		
.		
Port 29	HUNT	Port 30
Port 30	HUNT	Port 1

To Set Up an ACD Hunt Group for More Than 30 Ports

-
- Step 1** Set up ACD 1 as the pilot number of the hunt group.
 - Step 2** With the Night Call Forward Destination (NCFW) command, set ACD 1 to forward to the first voice messaging port.
 - Step 3** Set the first voice messaging port to hunt to the second, then continue up to the 30th.
 - Step 4** Set the 30th voice messaging port to hunt to ACD 2.
 - Step 5** With the NCFW command, set ACD 2 to forward to the 31st voice messaging port.
 - Step 6** Set the 31st voice messaging port to hunt to the 32nd, and so on.
 - Step 7** Continue creating 30-port hunt groups in this manner until the last voice messaging port.
 - Step 8** Set the last voice messaging port to hunt to ACD 1.

Table 9 Example of a 72-Port ACD Hunt Group

Device	Setting	Destination
ACD 1 (pilot number)	NCFW	Port 1
Port 1	HUNT	Port 2
Port 2	HUNT	Port 3
<additional ports>		<additional ports>
Port 29	HUNT	Port 30
Port 30	HUNT	ACD 2
ACD 2	NCFW	Port 31
Port 31	HUNT	Port 32
<additional ports>		<additional ports>
Port 59	HUNT	Port 60
Port 60	HUNT	ACD 3
ACD 3	NCFW	Port 61
Port 61	HUNT	Port 62
<additional ports>		<additional ports>
Port 71	HUNT	Port 72
Port 72	HUNT	ACD 1

Setting up the PBXLink Box

When setting up the PBXLink box, you can access the configuration menus through:

- A terminal access application such as HyperTerminal. Set the application to 1200 baud, even parity, 7 data bits, and 1 stop bit.
- The display panel and buttons on top of the PBXLink box. For details, refer to the PBXLink documentation, which is available from the manufacturer.

Do the following procedures.

To Update the PBXLink Box Firmware

- Step 1** In a web browser on your computer, go to the **Cisco Unity Utilities Software Download** page at <http://www.cisco.com/cgi-bin/tablebuild.pl/unity-util>.



Note To access the software download page, you must be logged on to Cisco.com as a registered user.

- Step 2** Click **PBXLinkFirmwareUpdate**.
- Step 3** Follow the instructions to download the PBXLink box firmware update file to your computer.

- Step 4** Exit the web browser.
- Step 5** Confirm that the PBXLink box is connected to power and turned on.
- Step 6** Disconnect the following cables:
- All phone cables connect to the PBXLink box.
 - The RS-232 serial cable connected to the Management port
- Step 7** Connect one end of an RS-232 serial cable to the Management port of the PBXLink box and the other end of the serial cable to the serial port of your computer.
- Step 8** On your computer, start HyperTerminal or another terminal access application.
- Step 9** Set the terminal access application to use the serial connection settings used by the PBXLink box. You can view the PBXLink serial connection settings by doing the following:
- a. On the PBXLink box, press **Cancel** until the Configuration menu appears.
 - b. Click **OK**.
 - c. Scroll up until Serial Port Options appears, and click **OK**.
 - d. Scroll down until Management Port appears, and click **OK**.
 - e. Scroll through the serial port settings to verify them.
- Step 10** Restart the PBXLink box.
- Step 11** In the HyperTerminal window on your computer, press **M** and press **Enter**.
- Step 12** Press **3** (Reboot/Download), and press **Enter**.
- Step 13** Press **2** (Reboot & Download Code), and press **Enter**.



Note Ignore any unusual characters that may appear on the screen.

- Step 14** On the Transfer menu, click **Send File**.
- Step 15** In the Send File dialog box, under Filename, click **Browse**.
- Step 16** Browse to the PBXLink box firmware upgrade file that you downloaded to your computer.
- Step 17** In the Send File dialog box, under Protocol, click **Xmodem**.
- Step 18** Click **Send**.
- Step 19** When the firmware upgrade is complete, exit HyperTerminal.
- Step 20** Repeat [Step 5](#) through [Step 19](#) for all remaining PBXLink boxes.
- Step 21** Connect the PBXLink boxes to the phone system and to the Cisco Unity server.
-

To Set Up the PBXLink Box

- Step 1** Select **Configuration** and press **Enter**.
- Step 2** Select **PBX Options** and press **Enter**. The list of phone systems appears.
- Step 3** Select **Nortel M1** and press **Enter**. The interface leaves the menu system.
- Step 4** If you are using HyperTerminal, enter **M** and press **Enter**. Then enter **1** and press **Enter**.
- Step 5** Select **PBX Options** and press **Enter**.

- Step 6** Select **Analog Ports on A**, enter the number of voice messaging ports that Port A monitors, and then press **Enter**.
- Step 7** If you are setting up a PBXLink-48 box, select **Analog Ports on B**, enter the number of voice messaging ports that Port B monitors, and then press **Enter**. Otherwise, skip to the next step.
- Step 8** Select **Configure Port A**, select one of the following settings for Port A, and then press **Enter**.

Table 10 Port Configuration Settings

Setting	Meaning
Calls Only	The port handles only calls.
MWI Only	The port handles only MWIs.

- Step 9** If you are setting up a PBXLink-48 box, select **Configure Port B**, select one of the preceding settings for Port B, and then press **Enter**. Otherwise, skip to the next step.
- Step 10** Select **Prime Number**, enter the pilot number for Cisco Unity, and then press **Enter**.
- Step 11** Select **Call Forward Display**, enter the option settings as shown in the following table, and then press **Enter**.

Table 11 Call Forward Display Options

Option	Setting
CFWD	<ul style="list-style-type: none"> CFWD (only if you do not use ACD hunt groups) DIR (only if you use ACD groups)
CFNA	CFNA
HUNT	HUNT

If the system has two or more PBXLink digital ports, we recommend that you balance the load among the PBXLink boxes by setting up the Port LTNs for random operation. Depending on the number of PBXLink digital ports your system uses, do the applicable procedure that follows:

- [To Set Up the Port LTNs for Two PBXLink Digital Ports, page 15](#)
- [To Set Up the Port LTNs for Three PBXLink Digital Ports, page 16](#)

To Set Up the Port LTNs for Two PBXLink Digital Ports

This procedure sets up the port LTNs for every second voice messaging port.

- Step 1** Select **Configuration** and press **Enter**. Then select **SMDI Options** and press **Enter**.
- Step 2** Select **Port A LTNs** (or the port that handles calls), select **Random**, and then press **Enter**.
- Step 3** Select **Setup Random LTNs**, enter the voice messaging port values (not the extension) as shown in the following table, and then press **Enter**.

Table 12 *Random LTN Settings for Odd-Numbered Ports*

LTN Number	Voice Messaging Port Value
0	0001
1	0003
2	0005
.	<the remaining odd-numbered voice messaging ports>
.	
.	

Step 4 Repeat [Step 1](#) through [Step 2](#) on the interface of the next PBXLink box.

Step 5 Select **Setup Random LTNs**, enter the voice messaging port values (not the extension) as shown in the following table, and then press **Enter**.

Table 13 *Random LTN Settings for Even-Numbered Ports*

LTN Number	Voice Messaging Port Value
0	0002
1	0004
2	0006
.	<the remaining even-numbered voice messaging ports>
.	
.	

Step 6 Select **Integration**, select **Started**, and then press **Enter**.

To Set Up the Port LTNs for Three PBXLink Digital Ports

This procedure sets up the port LTNs for every third voice messaging port.

Step 1 Select **Configuration** and press **Enter**. Then select **SMDI Options** and press **Enter**.

Step 2 Select **Port A LTNs** (or the port that handles calls), select **Random**, and then press **Enter**.

Step 3 Select **Setup Random LTNs**, enter the voice messaging port values (not the extension) as shown in the following table, and then press **Enter**.

Table 14 *Random LTN Settings for the First Set of Ports*

LTN Number	Voice Messaging Port Value
0	0001
1	0004
2	0007
.	<the remaining voice messaging ports in the first set>
.	
.	

- Step 4** Repeat [Step 1](#) and [Step 2](#) on the interface of the next PBXLink box.
- Step 5** Select **Setup Random LTNs**, enter the voice messaging port values (not the extension) as shown in the following table, and then press **Enter**.

Table 15 *Random LTN Settings for the Second Set of Ports*

LTN Number	Voice Messaging Port Value
0	0002
1	0005
2	0008
.	<the remaining voice messaging ports in the second set>
.	
.	

- Step 6** Repeat [Step 1](#) and [Step 2](#) on the interface of the next PBXLink box.
- Step 7** Select **Setup Random LTNs**, enter the voice messaging port values (not the extension) as shown in the following table, and then press **Enter**.

Table 16 *Random LTN Settings for the Third Set of Ports*

LTN Number	Voice Messaging Port Value
0	0003
1	0006
2	0009
.	<the remaining voice messaging ports in the third set>
.	
.	

- Step 8** Select **Integration**, select **Started**, and then press **Enter**.

Creating a New Integration with the Nortel Meridian/PBXLink Phone System

After ensuring that the Nortel Meridian/PBXLink phone system and the Cisco Unity server are ready for the integration, do the following procedures to set up the integration and to enter the port settings.

To Create an Integration

- Step 1** If UTIM is not already open, on the Windows Start menu of the Cisco Unity server, click **Programs > Cisco Unity > Manage Integrations**. UTIM appears.
- Step 2** In the left pane of the UTIM window, click **Cisco Unity Server**.
- Step 3** On the Integration menu of the UTIM window, click **New**. The Telephony Integration Setup Wizard appears.

- Step 4** On the Welcome page, click **Circuit-Switched via Voice Card** and click **Next**.
- Step 5** On the Name the Phone System Integration page, accept the default name or enter the phone system name to identify this integration, then click **Next**.
- Step 6** On the Select Integration Method page, click **Serial**, then click **Next**.
- Step 7** On the Select Phone System Manufacturer page, click the following settings, then click **Next**.

Table 17 Settings for the Select Phone System Manufacturer Page

Field	Setting
Manufacturer	Nortel
Model	Meridian-1
Software Version	All
Configuration File	<if you have made copies of the .ini configuration file, the name of the configuration file that you want to use>

- Step 8** On the Select Serial Integration Packet Settings page, enter the following settings, then click **Next**.

Table 18 Settings for the Select Serial Integration Packet Settings Page

Field	Setting
Station Field Length	<the station prefix plus the default extension length; accept the default or click another setting; this length is either 10 or 7>
Default Extension Length	<the default length of extensions on the phone system; accept the default or click another setting>

- Step 9** On the Select COM Port Settings page, enter the following settings, then click **Next**.

Table 19 Settings for the Select COM Port Settings Page

Field	Setting
COM Port	<the communications port on the Cisco Unity server that will receive the call information; typically, this setting is 1>
Baud Rate	<the baud rate that the phone system uses>
Data Bits	<the number of data bits that the phone system uses>
Stop Bits	<the number of stop bits that the phone system uses>
Parity	<the parity that the phone system uses>

- Step 10** On the Set Number of Voice Messaging Ports page, enter the number of voice messaging ports on Cisco Unity that you want to connect to the phone system, then click **Next**.
- This number cannot be more than the number of ports on the installed voice cards or the number of ports set up on the phone system.
- Step 11** If other integrations already exist, the Enter Trunk Access Code page appears. Enter the extra digits that Cisco Unity must use to transfer calls through the gateway to extensions on the other phone systems with which it is integrated. Then click **Next**.

Step 12 On the Reassign Subscribers page, any subscribers whose phone system integration has been deleted and who are not currently assigned to a phone system integration will appear in the list.

If no subscribers appear in the list, click **Next** and continue to [Step 13](#).

Otherwise, select the subscribers that you want to assign to this phone system integration and click **Next**. You can use the following selection controls for selecting subscribers.

Table 20 **Selection Controls for the Reassign Subscribers Page**

Selection Control	Effect
Check All	Checks the check boxes for all subscribers in the list.
Uncheck All	Unchecks the check boxes for all subscribers in the list.
Toggle Selected	For the subscribers highlighted in the list, toggles between checking and unchecking the check boxes. If some highlighted subscriber check boxes are checked and others are unchecked, clicking this button will check all the check boxes. Clicking again will uncheck all the check boxes.

Step 13 On the Reassign Call Handlers page, any call handlers whose phone system integration has been deleted and that are not currently assigned to a phone system integration will appear in the list.

If no call handlers appear in the list, click **Next** and continue to [Step 14](#).

Otherwise, select the call handlers that you want to assign to this phone system integration and click **Next**. You can use the following selection controls for selecting call handlers.

Table 21 **Selection Controls for the Reassign Call Handlers Page**

Selection Control	Effect
Check All	Checks the check boxes for all call handlers in the list.
Uncheck All	Unchecks the check boxes for all call handlers in the list.
Toggle Selected	For the call handlers highlighted in the list, toggles between checking and unchecking the check boxes. If some highlighted call handler check boxes are checked and others are unchecked, clicking this button will check all the check boxes. Clicking again will uncheck all the check boxes.

Step 14 On the Completing page, verify the settings you entered, then click **Finish**.

Step 15 At the prompt to restart the Cisco Unity services, click **Yes**. The Cisco Unity services restart.

Alternatively, you can restart the Cisco Unity services in UTIM on the Tools menu by clicking **Restart Cisco Unity**.

To Enter the Voice Messaging Port Settings for the Integration

Step 1 After the Cisco Unity services restart, on the View menu, click **Refresh**.

Step 2 In the left pane of the UTIM window, expand the phone system integration that you are creating.

- Step 3** In the left pane, click the name of the phone system.
- Step 4** In the right pane, click the **Ports** tab.
- Step 5** Enter the settings shown in [Table 22](#) for the voice messaging ports.

For best performance, use the first voice messaging ports for incoming calls and the last ports to dial out. This helps minimize the possibility of a collision, in which an incoming call arrives on a port at the same time that Cisco Unity takes the port off-hook to dial out.

**Caution**

In programming the phone system, do not send calls to voice messaging ports in Cisco Unity that cannot answer calls (voice messaging ports that are not set to Answer Calls). For example, if a voice messaging port is set only to Message Notification, do not send calls to it.

Table 22 Settings for the Voice Messaging Ports

Field	Considerations
Extension	Enter the extension for the port as assigned on the phone system.
Enabled	Check this check box to enable the port. The port is enabled during normal operation. Uncheck this check box to disable the port. When the port is disabled, calls to the port get a ringing tone but are not answered. Typically, the port is disabled only by the installer during testing.
Answer Calls	Check this check box to designate the port for answering calls. These calls can be incoming calls from unidentified callers or from subscribers.
Message Notification	Check this check box to designate the port for notifying subscribers of messages. Assign Message Notification to the least busy ports.
Dialout MWI <i>(not used by serial or SMDI integrations)</i>	Check this check box to designate the port for turning MWIs on and off. Assign Dialout MWI to the least busy ports.
AMIS Delivery <i>(available with the AMIS licensed feature only)</i>	Check this check box to designate the port for making outbound AMIS calls to deliver voice messages from Cisco Unity subscribers to users on another voice messaging system. Cisco Unity supports the Audio Messaging Interchange Specification (AMIS) protocol, which provides an analog mechanism for transferring voice messages between different voice messaging systems. This setting affects outbound AMIS calls only. All ports are used for incoming AMIS calls. Because the transmission of outgoing AMIS messages may tie up voice ports for long periods of time, you may want to adjust the schedule on the Network > AMIS > Schedule page so that outgoing AMIS calls are placed during closed hours or at times when Cisco Unity is not processing many calls.
TRAP Connection	Check this check box so that subscribers can use the phone as a recording and playback device in Cisco Unity web applications and e-mail clients. Assign TRAP Connection to the least busy ports.

- Step 6** Click **Save**.
- Step 7** Exit UTIM.

If your phone system uses MWI extension numbers that begin with zero (for example, 0123 or 09876), do the following procedure.

To Enable MWI Extensions That Begin with Zero

-
- Step 1** On the Cisco Unity server, navigate to the \CommServer\Intlib directory on the drive on which you installed Cisco Unity.
- Step 2** In the Intlib directory, locate the file Avsmdi.avd.
- Step 3** Open the file in a text editor.
- Step 4** In the [Fields] section of the file, locate the following line:
- ```
$LAMPEXT= 10 ZR, LAMPEXT
```
- Step 5** Change the ZR switch to V so the line reads:
- ```
$LAMPEXT=      10 V,   LAMPEXT
```
- Step 6** Save the file and close the text editor.
- Step 7** For the settings to take effect, restart the Cisco Unity server.
-

Testing the Integration

To test whether Cisco Unity and the phone system are integrated correctly, do the following procedures in the order listed.

If any of the steps indicate a failure, refer to the following documentation as applicable:

- The installation guide for the phone system.
- *Cisco Unity Troubleshooting Guide*, available at http://www.cisco.com/en/US/products/sw/voicesw/ps2237/prod_troubleshooting_guides_list.html.
- The setup information earlier in this guide.

To Set Up the Test Configuration

-
- Step 1** Set up two test extensions (Phone 1 and Phone 2) on the same phone system that Cisco Unity is connected to.
- Step 2** Set Phone 1 to forward calls to the Cisco Unity pilot number when calls are not answered.



Caution The phone system must forward calls to the Cisco Unity pilot number in no fewer than four rings. Otherwise, the test may fail.

- Step 3** In the Cisco Unity Administrator, create a test subscriber to use for testing by doing the applicable substeps below.
- If your message store is Microsoft Exchange, do the following:
- In the Cisco Unity Administrator, go to the **Subscribers > Subscribers > Profile** page.
 - Click the **Add** icon.

- c. In the New subscriber field, click **Exchange**.
- d. On the Add Subscriber page, enter the applicable information.
- e. Click **Add**.

If your message store is IBM Lotus Domino, do the following:

- a. In the Cisco Unity Administrator, go to the **Subscribers > Subscribers > Profile** page.
- b. Click the **Add** icon.
- c. In the New Subscriber field, click **Notes**.
- d. In the Address Book list, confirm that the address book listed is the one that contains the user data that you want to import.

If the address book that you want to use is not listed, go to the **System > Configuration > Subscriber Address Books** page and add a different address book.

- e. In the Find Domino Person By list, indicate whether to search by short name, first name, or last name.
- f. Enter the applicable short name or name. You also can enter * to display a list of all users, or enter one or more characters followed by * to narrow your search.
- g. Click **Find**.
- h. On the list of matches, click the name of the user to import.
- i. On the Add Subscriber page, enter the applicable information.
- j. Click **Add**.

Step 4 In the Extension field, enter the extension of Phone 1.

Step 5 In the Active Schedule field, click **All Hours - All Days**.

Step 6 Click the **Save** icon.

Step 7 In the navigation bar, click **Call Transfer** to go to the Subscribers > Subscribers > Call Transfer page for the test subscriber.

For more information on transfer settings, refer to the “Subscriber Template Call Transfer Settings” section in the Cisco Unity Administrator Help.

Step 8 In the Transfer Rule Applies To field, click **Standard**.

Step 9 Under Transfer Incoming Calls, click **Yes, Ring Subscriber’s Extension**, and confirm that the extension number is for Phone 1.

Step 10 Under Transfer Type, click **Release to Switch**.

Step 11 Click the **Save** icon.

Step 12 In the navigation bar, click **Messages** to go to the Subscribers > Subscribers > Messages page for the test subscriber.

Step 13 Under Message Waiting Indicators (MWIs), check **Use MWI for Message Notification**.

Step 14 In the Extension field, enter **x**.

Step 15 Click the **Save** icon.

Step 16 Open the Status Monitor by doing one of the following:

- In Internet Explorer, go to **http://<Cisco Unity server name>/web/sm**.
- Double-click the desktop shortcut to the Status Monitor.

- In the status bar next to the clock, right-click the Cisco Unity tray icon and click **Status Monitor**.
-

To Test an External Call with Release Transfer

- Step 1** From Phone 2, enter the access code necessary to get an outside line, then enter the number outside callers use to dial directly to Cisco Unity.
- Step 2** On the Status Monitor, note which port handles this call.
- Step 3** When you hear the opening greeting, enter the extension for Phone 1. Hearing the opening greeting means that the port is configured correctly.
- Step 4** Confirm that Phone 1 rings and that you hear a ringback tone on Phone 2. Hearing a ringback tone means that Cisco Unity correctly released the call and transferred it to Phone 1.
- Step 5** Leaving Phone 1 unanswered, confirm that the state of the port handling the call changes to “Idle.” This state means that release transfer is successful.
- Step 6** Confirm that, after the number of rings that the phone system is set to wait, the call is forwarded to Cisco Unity and that you hear the greeting for the test subscriber. Hearing the greeting means that the phone system forwarded the unanswered call and the call-forward information to Cisco Unity, which correctly interpreted the information.
- Step 7** On the Status Monitor, note which port handles this call.
- Step 8** Leave a message for the test subscriber and hang up Phone 2.
- Step 9** On the Status Monitor, confirm that the state of the port handling the call changes to “Idle.” This state means that the port was successfully released when the call ended.
- Step 10** Confirm that the MWI on Phone 1 is activated. The activated MWI means that the phone system and Cisco Unity are successfully integrated for turning on MWIs.
-

To Test Listening to Messages

- Step 1** From Phone 1, enter the internal pilot number for Cisco Unity.
- Step 2** When asked for your password, enter the default password. Hearing the request for your password means that the phone system sent the necessary call information to Cisco Unity, which correctly interpreted the information.
- Step 3** Confirm that you hear the recorded voice name for the test subscriber (if you did not record a voice name for the test subscriber, you will hear the extension number for Phone 1). Hearing the voice name means that Cisco Unity correctly identified the subscriber by the extension.
- Step 4** When asked whether you want to listen to your message, press **1**.
- Step 5** After listening to the message, press **3** to delete the message.
- Step 6** Confirm that the MWI on Phone 1 is deactivated. The deactivated MWI means that the phone system and Cisco Unity are successfully integrated for turning off MWIs.
- Step 7** Hang up Phone 1.
- Step 8** On the Status Monitor, confirm that the state of the port handling the call changes to “Idle.” This state means that the port was successfully released when the call ended.
-

To Set Up Supervised Transfer on Cisco Unity

- Step 1** In the Cisco Unity Administrator, go to the **Subscribers > Subscribers > Call Transfer** page.
If the name of the test subscriber is not displayed, click the **Find** icon (the magnifying glass) in the title bar, then click **Find**, and select the name of the test subscriber in the list that appears.
For more information on transfer settings, refer to the “Subscriber Template Call Transfer Settings” section in the Cisco Unity Administrator Help.
- Step 2** Under Transfer Type, click **Supervise Transfer**.
- Step 3** Set the Rings to Wait For field to **3**.
- Step 4** Click the **Save** icon.
-

To Test Supervised Transfer

- Step 1** From Phone 2, enter the access code necessary to get an outside line, then enter the number outside callers use to dial directly to Cisco Unity.
- Step 2** On the Status Monitor, note which port handles this call.
- Step 3** When you hear the opening greeting, enter the extension for Phone 1. Hearing the opening greeting means that the port is configured correctly.
- Step 4** Confirm that Phone 1 rings and that you do not hear a ringback tone on Phone 2. Instead, you should hear the indication your phone system uses to mean that the call is on hold (for example, music or beeps).
- Step 5** Leaving Phone 1 unanswered, confirm that the state of the port handling the call remains “Busy.” This state and hearing an indication that you are on hold mean that Cisco Unity is supervising the transfer.
- Step 6** Confirm that, after three rings, you hear the greeting for the test subscriber. Hearing the greeting means that Cisco Unity successfully recalled the supervised-transfer call.
- Step 7** During the greeting, hang up Phone 2.
- Step 8** On the Status Monitor, confirm that the state of the port handling the call changes to “Idle.” This state means that the port was successfully released when the call ended.
-

To Delete the Test Subscriber

- Step 1** In the Cisco Unity Administrator, go to the **Subscribers > Subscribers > Profile** page.
If the name of the test subscriber is not displayed, click the **Find** icon (the magnifying glass) in the title bar, then click **Find**, and select the name of the test subscriber in the list that appears.
- Step 2** In the title bar, click the **Delete Subscriber** icon (the X).
- Step 3** Click **Delete**.
- Step 4** When prompted to confirm deleting the subscriber, click **OK**.
-

Integrating a Secondary Server for Cisco Unity Failover

The Cisco Unity failover feature enables a secondary server to provide voice messaging services when the primary server becomes inactive. For information on installing a secondary server for failover, refer to the applicable Cisco Unity installation guide, available at

http://www.cisco.com/en/US/products/sw/voicesw/ps2237/prod_installation_guides_list.html.

For information on failover, refer to the applicable *Cisco Unity Failover Configuration and Administration Guide* at

http://www.cisco.com/en/US/products/sw/voicesw/ps2237/products_feature_guides_list.html.

Requirements

The following components are required to integrate a secondary server:

Phone System

- A data splitter unit to split the single serial cable from the first PBXLink box (which connects to the Cisco Unity servers) into two serial cables.
- Two additional RS-232 serial cables (to be used with the serial cable that was connected from the PBXLink box directly to the primary server when it was integrated with the phone system). With these three serial cables, connect one serial cable from the SMDI port in the first PBXLink box to the data splitter unit; connect the second serial cable from the data splitter unit to the serial port on the primary server; and connect the third serial cable from the data splitter unit to the serial port on the secondary server.

Cisco Unity Server

- One secondary server for each primary server installed and ready for the integration, as described in the applicable Cisco Unity installation guide and earlier in this integration guide.
- The applicable cable configuration for each analog voice messaging port to simultaneously connect the phone system to the corresponding ports on both the primary and the secondary servers. For example, connect port 1 on the phone system with both port 1 on the primary server and port 1 on the secondary server.
- A license that enables failover.

Integration Description

The phone system uses PBXLink boxes to send call information to the primary and secondary servers. The analog voice messaging lines from the phone system provide voice connectivity to the primary and secondary servers. [Figure 3](#) shows the required connections.

Figure 3 Connections Between the Phone System and Cisco Unity Servers

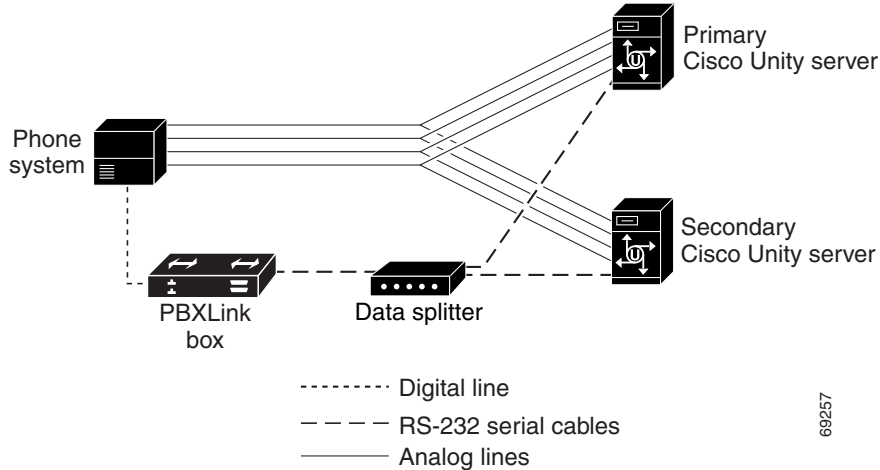

The primary and secondary servers act in the following manner:

- When the primary server is operating normally, the secondary server is inactive.
- When the primary server becomes inactive, the secondary server becomes active.
- When the primary server becomes active again, the secondary server becomes inactive.

Setting Up the Secondary Server for Failover

Do the following procedure to integrate the secondary server.

To Set Up the Secondary Server for Failover

- Step 1** Install a secondary server with the same configuration as the primary server. For installation instructions, refer to the applicable Cisco Unity installation guide.
- Step 2** Make all voice connections from the phone system to the corresponding ports on both the primary server and the secondary server. For example, connect port 1 from the phone system with port 1 on both the primary and the secondary servers.
- Step 3** Connect one serial cable from the SMDI port in the first PBXLink box to the data splitter unit.
- Step 4** Connect the remaining two serial cables to the two serial ports on the data splitter unit. Then connect one serial cable to the serial port on the primary server and the other serial cable to the serial port on the secondary server.
- Step 5** On the Windows Start menu of the secondary server, click **Programs > Cisco Unity > Manage Integrations**. The UTIM window appears.
- Step 6** On the Integration menu of the UTIM window, click **New**. The Telephony Integration Setup Wizard appears.
- Step 7** Enter the settings to match the integration settings on the primary server.



Note We recommend not reassigning any unassigned subscribers and call handlers to the new integration, if you are asked by the wizard. Failover replication will automatically assign the correct integration.

Step 8 At the prompt to restart the Cisco Unity services, click **Yes**.



Note When restarting the Cisco Unity services, use the UTIM prompt instead of the Cisco Unity icon in the Windows taskbar. The taskbar icon does not restart all of the Cisco Unity services.

Step 9 After Cisco Unity restarts, on the Windows Start menu of the Cisco Unity server, click **Programs > Cisco Unity > Manage Integrations**. UTIM appears.

Step 10 In the left pane of the UTIM window, click the phone system integration that you created in [Step 6](#).

Step 11 In the right pane, click **Properties**.

Step 12 On the Integration tab, compare the setting of the Integration ID field for the secondary server to the setting of the Integration ID field for the primary server.

Step 13 If the integration IDs of the phone system on the primary and secondary server are the same, continue to [Step 19](#).

If the integration IDs of the phone system on the primary and secondary servers are different, on the secondary server, click **Modify Integration ID**.

Step 14 When cautioned that subscribers associated with the current Integration ID setting will not be automatically associated with the new Integration ID setting, click **OK**.

Step 15 In the Modify Integration ID dialog box, in the Enter New Integration ID field, enter the Integration ID setting for the phone system on the primary server and click **OK**.

Step 16 Click **Save**.

Step 17 At the prompt to restart the Cisco Unity services, click **No**.

Step 18 In the left pane, click the phone system integration that you created in [Step 6](#).

Step 19 In the right pane, click the **Ports** tab.

Step 20 Enter the port settings to match the port settings on the primary server.



Caution In programming the phone system, do not send calls to voice messaging ports in Cisco Unity that cannot answer calls (voice messaging ports that are not set to Answer Calls). For example, if a voice messaging port is set only to Dialout MWI, do not send calls to it.

Step 21 Click **Save**.

Step 22 Exit UTIM.

Step 23 Click **Programs > Cisco Unity > Edit Switch Utility**.

Step 24 In the Switch Configuration Editor window, in the Manufacturer field, click **Nortel**.

Step 25 In the Model field, click **Meridian-1**.

Step 26 Click **Edit**.

Step 27 In the Switch Configuration dialog box, click the **Incoming Calls** tab.

Step 28 In the **Min. Ring on Time** field, enter **250**.

Step 29 In the Call Rings field, enter **1** and click **OK**.

Step 30 In the Switch Configuration Editor dialog box, click **Exit**.

Step 31 On the Windows Start menu, click **Run**.

Step 32 Enter **Regedit** and click **OK**.

**Caution**

Changing the wrong registry key or entering an incorrect value can cause the server to malfunction. Before you edit the registry, confirm that you know how to restore it if a problem occurs. (Refer to the “Restoring” topics in Registry Editor Help.) If you have any questions about changing registry key settings, contact Cisco TAC.

- Step 33** If you do not have a current backup of the registry, click **Registry > Export Registry File**, and save the registry settings to a file.
- Step 34** Expand the key HKEY_LOCAL_MACHINE\Software\Active Voice\Miu\1.0\Initialization.
- Step 35** Double-click **New Call Delay on Inactive Backup Server**.
- Step 36** In the Edit DWORD Value dialog box, in the Value Data field, enter **15000** (decimal), and click **OK**.
- Step 37** Close the Registry Editor.
- Step 38** Restart the Cisco Unity server.

No changes to the hunt group programming on the phone system are necessary.

Appendix: Programming Examples

The following programming examples show how overlay 11 on the Nortel Meridian 1 phone system enables the PBXLink boxes:

- [Programming in the Nortel Meridian 1, page 28](#)
- [Programming in the PBXLink Box, page 32](#)

Programming in the Nortel Meridian 1

PBXLink 1, Port A (MWIs only)

```
>LD 11
REQ   NEW
TYPE  2616
TN    8 0 0 3
DES
CUST  0
AOM   1
FDN
TGAR
NCOS
RNPG
SSU
CLS   ADD HFD CNDA DNDA
HUNT  000
LHK
KEY   00 SCR 2999
KEY   12 DSP
KEY   13 MIK
```

```
KEY 14 MCK
```

PBXLink 1, Port B (beginning with extension 2800)

```
>LD 11
REQ NEW
TYPE 2616
TN 8 0 0 4
DES
CUST 0
AOM 1
FDN
TGAR
NCOS
RNPG
SSU
CLS ADD HFD CNDA DNDA
HUNT 000
LHK
KEY 00 SCR 2999
KEY 05 SCN 2888
KEY 06 SCN 2892
KEY 12 DSP
KEY 13 MIK
KEY 14 MCK
KEY 16 SCN 2800
KEY 17 SCN 2804
KEY 18 SCN 2808
KEY 19 SCN 2812
KEY 20 SCN 2816
KEY 21 SCN 2820
KEY 22 SCN 2824
KEY 23 SCN 2828
KEY 24 SCN 2832
KEY 25 SCN 2836
KEY 26 SCN 2840
KEY 27 SCN 2844
KEY 28 SCN 2848
KEY 29 SCN 2852
KEY 30 SCN 2856
KEY 31 SCN 2860
KEY 32 SCN 2864
KEY 33 SCN 2868
KEY 34 SCN 2872
KEY 35 SCN 2876
KEY 36 SCN 2880
KEY 37 SCN 2884
```

PBXLink 2, Port A (beginning with extension 2801)

```
>LD 11
REQ NEW
TYPE 2616
TN 8 0 0 5
DES
CUST 0
AOM 1
FDN
TGAR
NCOS
RNPG
SSU
CLS ADD HFD CNDA DNDA
HUNT 000
```

```

LHK
KEY 00 SCR 2999
KEY 05 SCN 2889
KEY 06 SCN 2893
KEY 12 DSP
KEY 13 MIK
KEY 14 MCK
KEY 16 SCN 2801
KEY 17 SCN 2805
KEY 18 SCN 2809
KEY 19 SCN 2813
KEY 20 SCN 2817
KEY 21 SCN 2821
KEY 22 SCN 2825
KEY 23 SCN 2829
KEY 24 SCN 2833
KEY 25 SCN 2837
KEY 26 SCN 2841
KEY 27 SCN 2845
KEY 28 SCN 2849
KEY 29 SCN 2853
KEY 30 SCN 2857
KEY 31 SCN 2861
KEY 32 SCN 2865
KEY 33 SCN 2869
KEY 34 SCN 2873
KEY 35 SCN 2877
KEY 36 SCN 2881
KEY 37 SCN 2885

```

PBXLink 2, Port B (beginning with extension 2802)

```

>LD 11
REQ NEW
TYPE 2616
TN 8 0 0 6
DES
CUST 0
AOM 1
FDN
TGAR
NCOS
RNPG
SSU
CLS ADD HFD CNDA DNDA
HUNT 000
LHK
KEY 00 SCR 2999
KEY 05 SCN 2890
KEY 06 SCN 2894
KEY 12 DSP
KEY 13 MIK
KEY 14 MCK
KEY 16 SCN 2802
KEY 17 SCN 2806
KEY 18 SCN 2810
KEY 19 SCN 2814
KEY 20 SCN 2818
KEY 21 SCN 2822
KEY 22 SCN 2826
KEY 23 SCN 2830
KEY 24 SCN 2834
KEY 25 SCN 2838
KEY 26 SCN 2842

```

```
KEY 27 SCN 2846
KEY 28 SCN 2850
KEY 29 SCN 2854
KEY 30 SCN 2858
KEY 31 SCN 2862
KEY 32 SCN 2866
KEY 33 SCN 2870
KEY 34 SCN 2874
KEY 35 SCN 2878
KEY 36 SCN 2882
KEY 37 SCN 2886
```

PBXLink 3, Port A (beginning with extension 2803)

```
>LD 11
REQ NEW
TYPE 2616
TN 8 0 0 7
DES
CUST 0
AOM 1
FDN
TGAR
NCOS
RNPG
SSU
CLS ADD HFD CNDA DNDA
HUNT 000
LHK
KEY 00 SCR 2999
KEY 05 SCN 2891
KEY 06 SCN 2895
KEY 12 DSP
KEY 13 MIK
KEY 14 MCK
KEY 16 SCN 2803
KEY 17 SCN 2807
KEY 18 SCN 2811
KEY 19 SCN 2815
KEY 20 SCN 2819
KEY 21 SCN 2823
KEY 22 SCN 2827
KEY 23 SCN 2831
KEY 24 SCN 2835
KEY 25 SCN 2839
KEY 26 SCN 2843
KEY 27 SCN 2847
KEY 28 SCN 2851
KEY 29 SCN 2855
KEY 30 SCN 2859
KEY 31 SCN 2863
KEY 32 SCN 2867
KEY 33 SCN 2871
KEY 34 SCN 2875
KEY 35 SCN 2879
KEY 36 SCN 2883
KEY 37 SCN 2887
```

Analog Voice Messaging Line

```
>LD 10
REQ NEW
TYPE 500
TN 4 0 8 0
```

```
DES
CUST 0
DN 2800
HUNT 2801
CLS HTA FBD DTN XFA FND MWD LDTA
```

ACD Hunt Group

```
>LD 23
REQ NEW
TYPE ACD
CUST 0
ACDN 7000
MAXP 1
NCFW 2800 (1st analog voice mail extension)
OVBU LNK LNK LNK LNK
```

```
REQ NEW
TYPE ACD
CUST 0
ACDN 7001
MAXP 1
NCFW 2824 (25th analog voice mail extension)
OVBU LNK LNK LNK LNK
```

```
>LD 23
REQ NEW
TYPE ACD
CUST 0
ACDN 7002
MAXP 1
NCFW 2848 (49th analog voice mail extension)
OVBU LNK LNK LNK LNK
```

```
REQ NEW
TYPE ACD
CUST 0
ACDN 7003
MAXP 1
NCFW 2872 (73rd analog voice mail extension)
OVBU LNK LNK LNK LNK
```

Programming in the PBXLink Box

PBXLink Box 1

```
Configuration>PBXType>SelectPBXType = Nortel M1
Configuration>PBXOptions>AnalogPortsOnB = 24
Configuration>PBXOptions>ConfigurePortA = MWI Only
Configuration>PBXOptions>ConfigurePortB = Calls Only
Configuration>PBXOptions>PrimeNumber = 7000
Configuration>PBXOptions>CallForwardDisplay>CFWD = DIR (if Prime# is ACD)
Configuration>PBXOptions>CallForwardDisplay>CFNA = CFNA
Configuration>PBXOptions>CallForwardDisplay>HUNT = HUNT
Configuration>PBXOptions>ExtensionLength = 4
Configuration>SMDIOptions>MsgDeskNumber = 001
Configuration>SMDIOptions>CPIDLength = 10
Configuration>SMDIOptions>CPIDMask = 0000000000
Configuration>SMDIOptions>PortBLTNs>ModeOfOperation = Random
Configuration>SMDIOptions>PortBLTNs>SetupRandomLTNs>LTNsForPort0 = 0001
Configuration>SMDIOptions>PortBLTNs>SetupRandomLTNs>LTNsForPort1 = 0005
```

```

Configuration>SMDIOptions>PortBLTNs>SetupRandomLTNs>LTNsForPort2 = 0009
Configuration>SMDIOptions>PortBLTNs>SetupRandomLTNs>LTNsForPort3 = 0013
Configuration>SMDIOptions>PortBLTNs>SetupRandomLTNs>LTNsForPort4 = 0017
Configuration>SMDIOptions>PortBLTNs>SetupRandomLTNs>LTNsForPort5 = 0021
Configuration>SMDIOptions>PortBLTNs>SetupRandomLTNs>LTNsForPort6 = 0025
Configuration>SMDIOptions>PortBLTNs>SetupRandomLTNs>LTNsForPort7 = 0029
Configuration>SMDIOptions>PortBLTNs>SetupRandomLTNs>LTNsForPort8 = 0033
Configuration>SMDIOptions>PortBLTNs>SetupRandomLTNs>LTNsForPort9 = 0037
Configuration>SMDIOptions>PortBLTNs>SetupRandomLTNs>LTNsForPort10 = 0041
Configuration>SMDIOptions>PortBLTNs>SetupRandomLTNs>LTNsForPort11 = 0045
Configuration>SMDIOptions>PortBLTNs>SetupRandomLTNs>LTNsForPort12 = 0049
Configuration>SMDIOptions>PortBLTNs>SetupRandomLTNs>LTNsForPort13 = 0053
Configuration>SMDIOptions>PortBLTNs>SetupRandomLTNs>LTNsForPort14 = 0057
Configuration>SMDIOptions>PortBLTNs>SetupRandomLTNs>LTNsForPort15 = 0061
Configuration>SMDIOptions>PortBLTNs>SetupRandomLTNs>LTNsForPort16 = 0065
Configuration>SMDIOptions>PortBLTNs>SetupRandomLTNs>LTNsForPort17 = 0069
Configuration>SMDIOptions>PortBLTNs>SetupRandomLTNs>LTNsForPort18 = 0073
Configuration>SMDIOptions>PortBLTNs>SetupRandomLTNs>LTNsForPort19 = 0077
Configuration>SMDIOptions>PortBLTNs>SetupRandomLTNs>LTNsForPort20 = 0081
Configuration>SMDIOptions>PortBLTNs>SetupRandomLTNs>LTNsForPort21 = 0085
Configuration>SMDIOptions>PortBLTNs>SetupRandomLTNs>LTNsForPort22 = 0089
Configuration>SMDIOptions>PortBLTNs>SetupRandomLTNs>LTNsForPort23 = 0093
Configuration>SMDIOptions>TrunkGroups = Ignore Trunk Groups
Configuration>SerialPortOptions>SMDIPort>BaudRate = 1200
Configuration>SerialPortOptions>SMDIPort>FlowControl = OFF
Configuration>SerialPortOptions>SMDIPort>ParityEtc. = E,7,1
Configuration>SerialPortOptions>ManagementPort>BaudRate = 1200
Configuration>SerialPortOptions>ManagementPort>FlowControl = OFF
Configuration>SerialPortOptions>ManagementPort>ParityEtc. = E,7,1

```

PBXLink Box 2

```

Configuration>PBXType>SelectPBXType = Nortel M1
Configuration>PBXOptions>AnalogPortsOnA = 24
Configuration>PBXOptions>AnalogPortsOnB = 24
Configuration>PBXOptions>ConfigurePortA = Calls Only
Configuration>PBXOptions>ConfigurePortB = Calls Only
Configuration>PBXOptions>PrimeNumber = 7000
Configuration>PBXOptions>CallForwardDisplay>CFWD = DIR (if Prime# is ACD)
Configuration>PBXOptions>CallForwardDisplay>CFNA = CFNA
Configuration>PBXOptions>CallForwardDisplay>HUNT = HUNT
Configuration>PBXOptions>ExtensionLength = 4
Configuration>SMDIOptions>MsgDeskNumber = 001
Configuration>SMDIOptions>CPIDLength = 10
Configuration>SMDIOptions>CPIDMask = 000000000
Configuration>SMDIOptions>PortALTNs>ModeOfOperation = Random
Configuration>SMDIOptions>PortALTNs>SetupRandomLTNs>LTNsForPort0 = 0002
Configuration>SMDIOptions>PortALTNs>SetupRandomLTNs>LTNsForPort1 = 0006
Configuration>SMDIOptions>PortALTNs>SetupRandomLTNs>LTNsForPort2 = 0010
Configuration>SMDIOptions>PortALTNs>SetupRandomLTNs>LTNsForPort3 = 0014
Configuration>SMDIOptions>PortALTNs>SetupRandomLTNs>LTNsForPort4 = 0018
Configuration>SMDIOptions>PortALTNs>SetupRandomLTNs>LTNsForPort5 = 0022
Configuration>SMDIOptions>PortALTNs>SetupRandomLTNs>LTNsForPort6 = 0026
Configuration>SMDIOptions>PortALTNs>SetupRandomLTNs>LTNsForPort7 = 0030
Configuration>SMDIOptions>PortALTNs>SetupRandomLTNs>LTNsForPort8 = 0034
Configuration>SMDIOptions>PortALTNs>SetupRandomLTNs>LTNsForPort9 = 0038
Configuration>SMDIOptions>PortALTNs>SetupRandomLTNs>LTNsForPort10 = 0042
Configuration>SMDIOptions>PortALTNs>SetupRandomLTNs>LTNsForPort11 = 0046
Configuration>SMDIOptions>PortALTNs>SetupRandomLTNs>LTNsForPort12 = 0050
Configuration>SMDIOptions>PortALTNs>SetupRandomLTNs>LTNsForPort13 = 0054
Configuration>SMDIOptions>PortALTNs>SetupRandomLTNs>LTNsForPort14 = 0058
Configuration>SMDIOptions>PortALTNs>SetupRandomLTNs>LTNsForPort15 = 0062
Configuration>SMDIOptions>PortALTNs>SetupRandomLTNs>LTNsForPort16 = 0066
Configuration>SMDIOptions>PortALTNs>SetupRandomLTNs>LTNsForPort17 = 0070

```

```

Configuration>SMDIOptions>PortALTNs>SetupRandomLTNs>LTNsForPort18 = 0074
Configuration>SMDIOptions>PortALTNs>SetupRandomLTNs>LTNsForPort19 = 0078
Configuration>SMDIOptions>PortALTNs>SetupRandomLTNs>LTNsForPort20 = 0082
Configuration>SMDIOptions>PortALTNs>SetupRandomLTNs>LTNsForPort21 = 0086
Configuration>SMDIOptions>PortALTNs>SetupRandomLTNs>LTNsForPort22 = 0090
Configuration>SMDIOptions>PortALTNs>SetupRandomLTNs>LTNsForPort23 = 0094
Configuration>SMDIOptions>PortBLTNs>ModeOfOperation = Random
Configuration>SMDIOptions>PortBLTNs>SetupRandomLTNs>LTNsForPort0 = 0003
Configuration>SMDIOptions>PortBLTNs>SetupRandomLTNs>LTNsForPort1 = 0007
Configuration>SMDIOptions>PortBLTNs>SetupRandomLTNs>LTNsForPort2 = 0011
Configuration>SMDIOptions>PortBLTNs>SetupRandomLTNs>LTNsForPort3 = 0015
Configuration>SMDIOptions>PortBLTNs>SetupRandomLTNs>LTNsForPort4 = 0019
Configuration>SMDIOptions>PortBLTNs>SetupRandomLTNs>LTNsForPort5 = 0023
Configuration>SMDIOptions>PortBLTNs>SetupRandomLTNs>LTNsForPort6 = 0027
Configuration>SMDIOptions>PortBLTNs>SetupRandomLTNs>LTNsForPort7 = 0031
Configuration>SMDIOptions>PortBLTNs>SetupRandomLTNs>LTNsForPort8 = 0035
Configuration>SMDIOptions>PortBLTNs>SetupRandomLTNs>LTNsForPort9 = 0039
Configuration>SMDIOptions>PortBLTNs>SetupRandomLTNs>LTNsForPort10 = 0043
Configuration>SMDIOptions>PortBLTNs>SetupRandomLTNs>LTNsForPort11 = 0047
Configuration>SMDIOptions>PortBLTNs>SetupRandomLTNs>LTNsForPort12 = 0051
Configuration>SMDIOptions>PortBLTNs>SetupRandomLTNs>LTNsForPort13 = 0055
Configuration>SMDIOptions>PortBLTNs>SetupRandomLTNs>LTNsForPort14 = 0059
Configuration>SMDIOptions>PortBLTNs>SetupRandomLTNs>LTNsForPort15 = 0063
Configuration>SMDIOptions>PortBLTNs>SetupRandomLTNs>LTNsForPort16 = 0067
Configuration>SMDIOptions>PortBLTNs>SetupRandomLTNs>LTNsForPort17 = 0071
Configuration>SMDIOptions>PortBLTNs>SetupRandomLTNs>LTNsForPort18 = 0075
Configuration>SMDIOptions>PortBLTNs>SetupRandomLTNs>LTNsForPort19 = 0079
Configuration>SMDIOptions>PortBLTNs>SetupRandomLTNs>LTNsForPort20 = 0083
Configuration>SMDIOptions>PortBLTNs>SetupRandomLTNs>LTNsForPort21 = 0087
Configuration>SMDIOptions>PortBLTNs>SetupRandomLTNs>LTNsForPort22 = 0091
Configuration>SMDIOptions>PortBLTNs>SetupRandomLTNs>LTNsForPort23 = 0095
Configuration>SMDIOptions>TrunkGroups = Ignore Trunk Groups
Configuration>SerialPortOptions>SMDIPort>BaudRate = 1200
Configuration>SerialPortOptions>SMDIPort>FlowControl = OFF
Configuration>SerialPortOptions>SMDIPort>ParityEtc. = E,7,1
Configuration>SerialPortOptions>ManagementPort>BaudRate = 1200
Configuration>SerialPortOptions>ManagementPort>FlowControl = OFF
Configuration>SerialPortOptions>ManagementPort>ParityEtc. = E,7,1

```

PBXLink Box 3

```

Configuration>PBXType>SelectPBXType = Nortel M1
Configuration>PBXOptions>AnalogPortsOnA = 24
Configuration>PBXOptions>ConfigurePortA = Calls Only
Configuration>PBXOptions>ConfigurePortB = Disabled
Configuration>PBXOptions>PrimeNumber = 7000
Configuration>PBXOptions>CallForwardDisplay>CFWD = DIR (if Prime# is ACD)
Configuration>PBXOptions>CallForwardDisplay>CFNA = CFNA
Configuration>PBXOptions>CallForwardDisplay>HUNT = HUNT
Configuration>PBXOptions>ExtensionLength = 4
Configuration>SMDIOptions>MsgDeskNumber = 001
Configuration>SMDIOptions>CPIDLength = 10
Configuration>SMDIOptions>CPIDMask = 0000000000
Configuration>SMDIOptions>PortALTNs>ModeOfOperation = Random
Configuration>SMDIOptions>PortALTNs>SetupRandomLTNs>LTNsForPort0 = 0004
Configuration>SMDIOptions>PortALTNs>SetupRandomLTNs>LTNsForPort1 = 0008
Configuration>SMDIOptions>PortALTNs>SetupRandomLTNs>LTNsForPort2 = 0012
Configuration>SMDIOptions>PortALTNs>SetupRandomLTNs>LTNsForPort3 = 0016
Configuration>SMDIOptions>PortALTNs>SetupRandomLTNs>LTNsForPort4 = 0020
Configuration>SMDIOptions>PortALTNs>SetupRandomLTNs>LTNsForPort5 = 0024
Configuration>SMDIOptions>PortALTNs>SetupRandomLTNs>LTNsForPort6 = 0028
Configuration>SMDIOptions>PortALTNs>SetupRandomLTNs>LTNsForPort7 = 0032
Configuration>SMDIOptions>PortALTNs>SetupRandomLTNs>LTNsForPort8 = 0036
Configuration>SMDIOptions>PortALTNs>SetupRandomLTNs>LTNsForPort9 = 0040

```

```

Configuration>SMDIOptions>PortALTNs>SetupRandomLTNs>LTNsForPort10 = 0044
Configuration>SMDIOptions>PortALTNs>SetupRandomLTNs>LTNsForPort11 = 0048
Configuration>SMDIOptions>PortALTNs>SetupRandomLTNs>LTNsForPort12 = 0052
Configuration>SMDIOptions>PortALTNs>SetupRandomLTNs>LTNsForPort13 = 0056
Configuration>SMDIOptions>PortALTNs>SetupRandomLTNs>LTNsForPort14 = 0060
Configuration>SMDIOptions>PortALTNs>SetupRandomLTNs>LTNsForPort15 = 0064
Configuration>SMDIOptions>PortALTNs>SetupRandomLTNs>LTNsForPort16 = 0068
Configuration>SMDIOptions>PortALTNs>SetupRandomLTNs>LTNsForPort17 = 0072
Configuration>SMDIOptions>PortALTNs>SetupRandomLTNs>LTNsForPort18 = 0076
Configuration>SMDIOptions>PortALTNs>SetupRandomLTNs>LTNsForPort19 = 0080
Configuration>SMDIOptions>PortALTNs>SetupRandomLTNs>LTNsForPort20 = 0084
Configuration>SMDIOptions>PortALTNs>SetupRandomLTNs>LTNsForPort21 = 0088
Configuration>SMDIOptions>PortALTNs>SetupRandomLTNs>LTNsForPort22 = 0092
Configuration>SMDIOptions>PortALTNs>SetupRandomLTNs>LTNsForPort23 = 0096
Configuration>SMDIOptions>TrunkGroups = Ignore Trunk Groups
Configuration>SerialPortOptions>SMDIPort>BaudRate = 1200
Configuration>SerialPortOptions>SMDIPort>FlowControl = OFF
Configuration>SerialPortOptions>SMDIPort>ParityEtc. = E,7,1
Configuration>SerialPortOptions>ManagementPort>BaudRate = 1200
Configuration>SerialPortOptions>ManagementPort>FlowControl = OFF
Configuration>SerialPortOptions>ManagementPort>ParityEtc. = E,7,1

```

Appendix: Documentation and Technical Assistance

Conventions

The *Nortel Meridian 1/PBXLink Integration Guide for Cisco Unity 5.0* uses the following conventions.

Table 23 *Nortel Meridian 1/PBXLink Integration Guide for Cisco Unity 5.0 Conventions*

Convention	Description
boldfaced text	Boldfaced text is used for: <ul style="list-style-type: none"> Key and button names. (Example: Click OK.) Information that you enter. (Example: Enter Administrator in the User Name box.)
< > (angle brackets)	Angle brackets are used around parameters for which you supply a value. (Example: In the Command Prompt window, enter ping <IP address> .)
- (hyphen)	Hyphens separate keys that must be pressed simultaneously. (Example: Press Ctrl-Alt-Delete .)
> (right angle bracket)	A right angle bracket is used to separate selections that you make: <ul style="list-style-type: none"> On menus. (Example: On the Windows Start menu, click Settings > Control Panel > Phone and Modem Options.) In the navigation bar of the Cisco Unity Administrator. (Example: Go to the System > Configuration > Settings page.)

Table 23 Nortel Meridian 1/PBXLink Integration Guide for Cisco Unity 5.0 Conventions

Convention	Description
[x] (square brackets)	Square brackets enclose an optional element (keyword or argument). (Example: [reg-e164])
[x y] (vertical line)	Square brackets enclosing keywords or arguments separated by a vertical line indicate an optional choice. (Example: [transport tcp transport udp])
{x y} (braces)	Braces enclosing keywords or arguments separated by a vertical line indicate a required choice. (Example: {tcp udp})

The *Nortel Meridian 1/PBXLink Integration Guide for Cisco Unity 5.0* also uses the following conventions:

**Note**

Means *reader take note*. Notes contain helpful suggestions or references to material not covered in the document.

**Caution**

Means *reader be careful*. In this situation, you might do something that could result in equipment damage or loss of data.

For descriptions and URLs of Cisco Unity documentation on Cisco.com, see the *About Cisco Unity Documentation*. The document is shipped with Cisco Unity and is available at http://www.cisco.com/en/US/products/sw/voicesw/ps2237/products_documentation_roadmaps_list.html.

Obtaining Documentation, Obtaining Support, and Security Guidelines

For information on obtaining documentation, obtaining support, providing documentation feedback, security guidelines, and also recommended aliases and general Cisco documents, see the monthly *What's New in Cisco Product Documentation*, which also lists all new and revised Cisco technical documentation, at:

<http://www.cisco.com/en/US/docs/general/whatsnew/whatsnew.html>

CCVP, the Cisco logo, and Welcome to the Human Network are trademarks of Cisco Systems, Inc.; Changing the Way We Work, Live, Play, and Learn is a service mark of Cisco Systems, Inc.; and Access Registrar, Aironet, Catalyst, CCDA, CCDP, CCIE, CCIP, CCNA, CCNP, CCSF, Cisco, the Cisco Certified Internetwork Expert logo, Cisco IOS, Cisco Press, Cisco Systems, Cisco Systems Capital, the Cisco Systems logo, Cisco Unity, Enterprise/Solver, EtherChannel, EtherFast, EtherSwitch, Fast Step, Follow Me Browsing, FormShare, GigaDrive, HomeLink, Internet Quotient, IOS, iPhone, IP/TV, iQ Expertise, the iQ logo, iQ Net Readiness Scorecard, iQuick Study, LightStream, Linksys, MeetingPlace, MGX, Networkers, Networking Academy, Network Registrar, PIX, ProConnect, ScriptShare, SMARTnet, StackWise, The Fastest Way to Increase Your Internet Quotient, and TransPath are registered trademarks of Cisco Systems, Inc. and/or its affiliates in the United States and certain other countries.

All other trademarks mentioned in this document or Website are the property of their respective owners. The use of the word partner does not imply a partnership relationship between Cisco and any other company. (0711R)

Any Internet Protocol (IP) addresses used in this document are not intended to be actual addresses. Any examples, command display output, and figures included in the document are shown for illustrative purposes only. Any use of actual IP addresses in illustrative content is unintentional and coincidental.

© 2007 Cisco Systems, Inc. All rights reserved.

