



Matra 6500 DTMF Integration Guide for Cisco Unity 5.0

Revised November 26, 2007

This document provides instructions for integrating the phone system with Cisco Unity.

Integration Tasks

Before doing the following tasks to integrate Cisco Unity with the Matra 6500 phone system, confirm that the Cisco Unity server is ready for the integration by completing the applicable tasks in the applicable Cisco Unity installation guide.

The following task list describes the process for creating the integration.

Task List to Create the Integration

Use the following task list to set up a new integration with the Matra 6500 phone system. If you are installing a new Cisco Unity server by using the applicable Cisco Unity installation guide, you may have already completed some of the following tasks.

1. Review the system and equipment requirements to confirm that all phone system and Cisco Unity server requirements have been met. See the [“Requirements” section on page 2](#).
2. Plan how the voice messaging ports will be used by Cisco Unity. See the [“Planning How the Voice Messaging Ports Will Be Used by Cisco Unity” section on page 3](#).
3. Program the Matra 6500 phone system and extensions. See the [“Programming the Matra 6500 Phone System” section on page 5](#).
4. Set up Cisco Unity call handlers for subscribers. See the [“Setting Up Cisco Unity Call Handlers” section on page 7](#).
5. Create the integration. See the [“Creating a New Integration with the Matra 6500 Phone System” section on page 8](#).
6. Test the integration. See the [“Testing the Integration” section on page 11](#).



Americas Headquarters:
Cisco Systems, Inc., 170 West Tasman Drive, San Jose, CA 95134-1706 USA

© 2007 Cisco Systems, Inc. All rights reserved.

- If you have a secondary server for Cisco Unity failover, integrate the secondary server. See the “[Integrating a Secondary Server for Cisco Unity Failover](#)” section on page 15.

Requirements

The Matra 6500 integration supports configurations of the following components:

Phone System

- Matra 6500 phone system (including 6530 and 6550).
- Software version 8 and later.
- The voice messaging ports in the phone system connected to the voice cards in the Cisco Unity server.
- The phone system ready for the integration, as described in the documentation for the phone system.

Cisco Unity Server

- The applicable voice cards, installed. For details, refer to the “Supported Circuit-Switched Phone System Integrations” section in the applicable *Supported Hardware and Software, and Support Policies* at http://www.cisco.com/en/US/products/sw/voicesw/ps2237/prod_installation_guides_list.html.
- Cisco Unity installed and ready for the integration, as described in the applicable Cisco Unity installation guide at http://www.cisco.com/en/US/products/sw/voicesw/ps2237/prod_installation_guides_list.html.
- A license that enables the appropriate number of voice messaging ports.

Integration Description

The Matra 6500 phone system communicates with the Cisco Unity server by using DTMF sequences. The voice messaging lines from the phone system connect to the analog voice cards in the Cisco Unity server. [Figure 1](#) shows the required connections.

Figure 1 Connections Between the Phone System and Cisco Unity

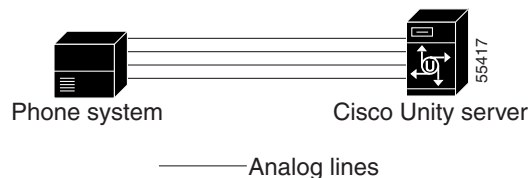

Call Information

The phone system sends the following information with forwarded calls:

- The extension of the called party

- The extension of the calling party (for internal calls) or the phone number of the calling party (if it is an external call and the system uses caller ID)

Cisco Unity uses this information to answer the call appropriately. For example, a call forwarded to Cisco Unity is answered with the personal greeting of the subscriber. If the phone system routes the call to Cisco Unity without this information, Cisco Unity answers with the opening greeting.

Integration Functionality

The Matra 6500 integration with Cisco Unity provides the following features:

- Call forward to personal greeting
- Caller ID
- Easy message access (a subscriber can retrieve messages without entering an ID because Cisco Unity identifies the subscriber based on the extension from which the call originated; a password may be required)
- Identified subscriber messaging (Cisco Unity identifies the subscriber who leaves a message during a forwarded internal call, based on the extension from which the call originated)
- Message waiting indication (MWI)

Integrations with Multiple Phone Systems

Cisco Unity can be integrated with multiple phone systems at one time. For information on the maximum supported combinations and instructions for integrating Cisco Unity with multiple phone systems, refer to the applicable *Multiple Phone System Integration Guide* at http://www.cisco.com/en/US/products/sw/voicesw/ps2237/products_installation_and_configuration_guides_list.html.

Planning How the Voice Messaging Ports Will Be Used by Cisco Unity

Before programming the phone system, you need to plan how the voice messaging ports will be used by Cisco Unity. The following considerations will affect the programming for the phone system (for example, setting up the hunt group or call forwarding for the voice messaging ports):

- The number of voice messaging ports installed.
- The number of voice messaging ports that will answer calls.
- The number of voice messaging ports that will only dial out, for example, to send message notification, to set message waiting indicators (MWIs), to make AMIS deliveries, and to make telephone record and playback (TRAP) connections.

The following table describes the voice messaging port settings in Cisco Unity that can be set in UTIM, and that are displayed as read-only text on the System > Ports page of the Cisco Unity Administrator.

Table 1 **Settings for the Voice Messaging Ports**

Field	Considerations
Extension	Enter the extension for the port as assigned on the phone system.
Enabled	Check this check box to enable the port. The port is enabled during normal operation. Uncheck this check box to disable the port. When the port is disabled, calls to the port get a ringing tone but are not answered. Typically, the port is disabled only by the installer during testing.
Answer Calls	Check this check box to designate the port for answering calls. These calls can be incoming calls from unidentified callers or from subscribers.
Message Notification	Check this check box to designate the port for notifying subscribers of messages. Assign Message Notification to the least busy ports.
Dialout MWI <i>(not used by serial or SMDI integrations)</i>	Check this check box to designate the port for turning MWIs on and off. Assign Dialout MWI to the least busy ports.
AMIS Delivery <i>(available with the AMIS licensed feature only)</i>	Check this check box to designate the port for making outbound AMIS calls to deliver voice messages from Cisco Unity subscribers to users on another voice messaging system. Cisco Unity supports the Audio Messaging Interchange Specification (AMIS) protocol, which provides an analog mechanism for transferring voice messages between different voice messaging systems. This setting affects outbound AMIS calls only. All ports are used for incoming AMIS calls. Because the transmission of outgoing AMIS messages may tie up voice ports for long periods of time, you may want to adjust the schedule on the Network > AMIS > Schedule page so that outgoing AMIS calls are placed during closed hours or at times when Cisco Unity is not processing many calls.
TRAP Connection	Check this check box so that subscribers can use the phone as a recording and playback device in Cisco Unity web applications and e-mail clients. Assign TRAP Connection to the least busy ports.

The Number of Voice Messaging Ports to Install

The number of voice messaging ports to install depends on numerous factors, including:

- The number of calls Cisco Unity will answer when call traffic is at its peak.
- The expected length of each message that callers will record and that subscribers will listen to.
- The number of subscribers.
- The number of ports that will be set to dial out only.
- The number of calls made for message notification.
- The number of MWIs that will be activated when call traffic is at its peak.
- The number of AMIS delivery calls.
- The number of TRAP connections needed when call traffic is at its peak. (TRAP connections are used by Cisco Unity web applications to play back and record over the phone.)
- The number of calls that will use the automated attendant and call handlers when call traffic is at its peak.

It is best to install only the number of voice messaging ports that are needed so that system resources are not allocated to unused ports.

The Number of Voice Messaging Ports That Will Answer Calls

The calls that the voice messaging ports answer can be incoming calls from unidentified callers or from subscribers. Typically, the voice messaging ports that answer calls are the busiest.

You can set voice messaging ports to both answer calls and to dial out (for example, to send message notifications). However, when the voice messaging ports perform more than one function and are very active (for example, answering many calls), the other functions may be delayed until the voice messaging port is free (for example, message notifications cannot be sent until there are fewer calls to answer). For best performance, dedicate certain voice messaging ports for only answering incoming calls, and dedicate other ports for only dialing out. Separating these port functions eliminates the possibility of a collision, in which an incoming call arrives on a port at the same time that Cisco Unity takes the port off-hook to dial out.

The Number of Voice Messaging Ports That Will Only Dial Out, and Not Answer Calls

Ports that will only dial out and will not answer calls can do one or more of the following:

- Notify subscribers by phone, pager, or e-mail of messages that have arrived.
- Turn MWIs on and off for subscriber extensions.
- Make outbound AMIS calls to deliver voice messages from Cisco Unity subscribers to users on another voice messaging system. (This action is available only with the AMIS licensed feature.)
- Make a TRAP connection so that subscribers can use the phone as a recording and playback device in Cisco Unity web applications.

Typically, these voice messaging ports are the least busy ports.



Caution

In programming the phone system, do not send calls to voice messaging ports in Cisco Unity that cannot answer calls (voice messaging ports that are not set to Answer Calls). For example, if a voice messaging port is set only to Dialout MWI, do not send calls to it.

Preparing for Programming the Phone System

Record your decisions about the voice messaging ports to guide you in programming the phone system.

Programming the Matra 6500 Phone System

If you use programming options other than those supplied in the following procedure, the performance of the integration may be affected.

The XMEVOC command requires the Q23 interface for integrating with Cisco Unity. The only supported voice mail type is Messagerie Vocale Q23. The V.24 interface is not supported. You can use this command to define:

- The Q23 DTMF digits sent to Cisco Unity to trigger integration features.
- The Q23 DTMF digits sent to the phone system to its features.

The XLIGAB command enables use of analog connections to Cisco Unity:

- Defining voice messaging ports as Répondeur Q23.
- Configuring all analog lines.

**Caution**

In programming the phone system, do not send calls to voice messaging ports in Cisco Unity that cannot answer calls (voice messaging ports that are not set to Answer Calls). For example, if a voice messaging port is set only to Dialout MWI, do not send calls to it.

Do the following procedure.

To Program the Matra 6500 Phone System

- Step 1** On the Matra 6500 phone system, use the XLIGAB command to view the **Abonné Téléphonique** page. Then configure each extension assigned to a voice messaging port with the following settings.

Table 2 *Voice Messing Port Extension Settings*

Option	Setting
Type de Poste	Répondeur Q23
No d'Abonné du Groupement	<the pilot number (tête de groupement) for the hunt group (groupement)>

- Step 2** Use the XGRABO command to view the **Tête de Groupement** page. Then assign the pilot number (tête de groupement) of the hunt group (groupement) with the following settings.

Table 3 *Pilot Number Settings*

Option	Setting
No d'Abonné du Groupement	<the pilot number (tête de groupement) for the hunt group>
Tête de Groupement	Normal
Type de Groupement	Cyclique

- Step 3** Assign the extensions for the voice messaging ports that answer calls to the hunt group (groupement) with the following settings.

Table 4 *Hunt Group Settings*

Option	Setting
UCG	<the cluster (grappe) that the extensions for the voice messaging ports belong to; all voice messaging ports must be in the same société, service, and grappe>
Numéro abonné	<the extension for the voice messaging port that answers calls>
Etat	Actif

- Step 4** Use the XGRABO command to view the **Facilités Dynamiques** page. Then assign the following settings for each extension in the hunt group.

Table 5 Call Forwarding Settings for Hunt Group Extensions

Option	Setting
Reroutage Systématique	Non Activée
Reroutage sur Occupation (forward when busy)	Activée
Num.	<the pilot number (tête de groupement) for the hunt group>
Type	Tous
Reroutage sur Non Réponse (forward when no answer)	Activée
Num.	<the pilot number (tête de groupement) for the hunt group>
Type	Tous

- Step 5** Program each phone to forward calls to the pilot number assigned to the voice messaging ports, based on one of the Cisco Unity call transfer types shown in [Table 6](#).

Table 6 Call Transfer Types

Transfer Type	Usage
Release transfer (blind transfer)	Program the phone to forward calls to the pilot number when: <ul style="list-style-type: none"> The extension is busy The call is not answered
Supervised transfer	Program the phone to forward calls to the pilot number only when the call is not answered. Confirm that call forwarding is disabled when the extension is busy.

Setting Up Cisco Unity Call Handlers

You must set up a call handler for each subscriber to enable the phone system to send callers to the mailbox for the subscriber they are calling.

Do the following procedure.

To Set Up Call Handlers for Subscribers

- Step 1** In the Cisco Unity Administrator, go to any **Call Management > Call Handlers** page.
- Step 2** Click the **Add** icon.
- Step 3** In the Add a Call Handler dialog box, enter the extension for a subscriber in the **Name** field. For example, if the subscriber extension is 4150, enter 4150.
- Step 4** Confirm that **New Call Handler** option is selected.
- Step 5** Click **Add**.

- Step 6** On the new call handler page, in the **Extension** field, enter **1**<the subscriber extension>. For example, if the subscriber extension is 4150, enter **14150**.
- Step 7** Go to the **Call Handlers > Call Transfer** page.
- Step 8** Set the **Transfer Rule Applies To** field to **Alternate**.
- Step 9** Confirm that the **Enabled** option is selected.
- Step 10** In the **Yes, Ring Subscriber** field, enter ***71**<the subscriber extension>#. For example, if the subscriber extension is 4150, enter ***714150#**.
- Step 11** Go to the **Call Handlers >**
- Step 12** Click the **Save** icon.
- Step 13** In the Save Confirm dialog box, click **Save**. The Add a Call Handler dialog box appears. Close the dialog box.
- Step 14** Go to the **Call Handlers > Greetings** page.
- Step 15** Under After Greetings, click the **Send Caller To** option and confirm that **Call Handler** is selected in the drop-down box.
- Step 16** Click **Select Call Handler**.
- Step 17** In the Select Call Handler dialog box, click **Find**.
- Step 18** In the Matching Call Handlers field, click the subscriber extension. For example, if the subscriber extension is 4150, click 4150.
- Step 19** Go to the **Call Handlers > Messages** page.
- Step 20** Under After Message Action, click the **Send Caller To** option and click **Hang Up** in the drop-down box.
- Step 21** Click the Save icon.
- Step 22** In the Save Confirm dialog box, click **Save**. The Add a Call Handler dialog box appears.
- Step 23** Repeat [Step 3](#) through [Step 13](#) for each remaining subscriber.

Creating a New Integration with the Matra 6500 Phone System

After ensuring that the Matra 6500 phone system and the Cisco Unity server are ready for the integration, do the following procedures to set up the integration and to enter the port settings.

To Create an Integration

- Step 1** If UTIM is not already open, on the Windows Start menu of the Cisco Unity server, click **Programs > Cisco Unity > Manage Integrations**. UTIM appears.
- Step 2** In the left pane of the UTIM window, click **Cisco Unity Server**.
- Step 3** On the Integration menu of the UTIM window, click **New**. The Telephony Integration Setup Wizard appears.
- Step 4** On the Welcome page, click **Circuit-Switched via Voice Card** and click **Next**.
- Step 5** On the Name the Phone System Integration page, accept the default name or enter another name to identify this integration, then click **Next**.

Step 6 On the Select Integration Method page, click **Analog**, then click **Next**.

Step 7 On the Select Phone System Manufacturer page, click the following settings, then click **Next**.

Table 7 Settings for the Select Phone System Manufacturer Page

Field	Setting
Manufacturer	Matra
Model	6500
Software Version	All
Configuration File	<if you have made copies of the .ini configuration file, the name of the configuration file that you want to use>

Step 8 On the Enter MWI Codes page, enter the following settings, then click **Next**.

Table 8 Settings for the Enter MWI Codes Page

Field	Setting
MWI On Code	<the code you specified in the phone system for turning MWIs on>
MWI Off Code	<the code you specified in the phone system for turning MWIs off>

Step 9 On the Set Number of Voice Messaging Ports page, enter the number of voice messaging ports on Cisco Unity that you want to connect to the phone system, then click **Next**.

This number cannot be more than the number of ports on the installed voice cards or the number of ports set up on the phone system.

Step 10 If other integrations already exist, the Enter Trunk Access Code page appears. Enter the extra digits that Cisco Unity must use to transfer calls through the gateway to extensions on the other phone systems with which it is integrated. Then click **Next**.

Step 11 On the Reassign Subscribers page, any subscribers whose phone system integration has been deleted and who are not currently assigned to a phone system integration will appear in the list.

If no subscribers appear in the list, click **Next** and continue to [Step 12](#).

Otherwise, select the subscribers that you want to assign to this phone system integration and click **Next**. You can use the following selection controls for selecting subscribers.

Table 9 Selection Controls for the Reassign Subscribers Page

Selection Control	Effect
Check All	Checks the check boxes for all subscribers in the list.
Uncheck All	Unchecks the check boxes for all subscribers in the list.
Toggle Selected	For the subscribers highlighted in the list, toggles between checking and unchecking the check boxes. If some highlighted subscriber check boxes are checked and others are unchecked, clicking this button will check all the check boxes. Clicking again will uncheck all the check boxes.

Step 12 On the Reassign Call Handlers page, any call handlers whose phone system integration has been deleted and that are not currently assigned to a phone system integration will appear in the list.

If no call handlers appear in the list, click **Next** and continue to [Step 13](#).

Otherwise, select the call handlers that you want to assign to this phone system integration and click **Next**. You can use the following selection controls for selecting call handlers.

Table 10 Selection Controls for the Reassign Call Handlers Page

Selection Control	Effect
Check All	Checks the check boxes for all call handlers in the list.
Uncheck All	Unchecks the check boxes for all call handlers in the list.
Toggle Selected	For the call handlers highlighted in the list, toggles between checking and unchecking the check boxes. If some highlighted call handler check boxes are checked and others are unchecked, clicking this button will check all the check boxes. Clicking again will uncheck all the check boxes.

Step 13 On the Completing page, verify the settings you entered, then click **Finish**.

Step 14 At the prompt to restart the Cisco Unity services, click **Yes**. The Cisco Unity services restart.

Alternatively, you can restart the Cisco Unity services in UTIM on the Tools menu by clicking **Restart Cisco Unity**.

To Enter the Voice Messaging Port Settings for the Integration

Step 1 After the Cisco Unity services restart, on the View menu, click **Refresh**.

Step 2 In the left pane of the UTIM window, expand the phone system integration that you are creating.

Step 3 In the left pane, click the name of the phone system.

Step 4 In the right pane, click the **Ports** tab.

Step 5 Enter the settings shown in [Table 11](#) for the voice messaging ports.

For best performance, use the first voice messaging ports for incoming calls and the last ports to dial out. This helps minimize the possibility of a collision, in which an incoming call arrives on a port at the same time that Cisco Unity takes the port off-hook to dial out.



Caution

In programming the phone system, do not send calls to voice messaging ports in Cisco Unity that cannot answer calls (voice messaging ports that are not set to Answer Calls). For example, if a voice messaging port is set only to Message Notification, do not send calls to it.

Table 11 **Settings for the Voice Messaging Ports**

Field	Considerations
Extension	Enter the extension for the port as assigned on the phone system.
Enabled	Check this check box to enable the port. The port is enabled during normal operation. Uncheck this check box to disable the port. When the port is disabled, calls to the port get a ringing tone but are not answered. Typically, the port is disabled only by the installer during testing.
Answer Calls	Check this check box to designate the port for answering calls. These calls can be incoming calls from unidentified callers or from subscribers.
Message Notification	Check this check box to designate the port for notifying subscribers of messages. Assign Message Notification to the least busy ports.
Dialout MWI <i>(not used by serial or SMDI integrations)</i>	Check this check box to designate the port for turning MWIs on and off. Assign Dialout MWI to the least busy ports.
AMIS Delivery <i>(available with the AMIS licensed feature only)</i>	Check this check box to designate the port for making outbound AMIS calls to deliver voice messages from Cisco Unity subscribers to users on another voice messaging system. Cisco Unity supports the Audio Messaging Interchange Specification (AMIS) protocol, which provides an analog mechanism for transferring voice messages between different voice messaging systems. This setting affects outbound AMIS calls only. All ports are used for incoming AMIS calls. Because the transmission of outgoing AMIS messages may tie up voice ports for long periods of time, you may want to adjust the schedule on the Network > AMIS > Schedule page so that outgoing AMIS calls are placed during closed hours or at times when Cisco Unity is not processing many calls.
TRAP Connection	Check this check box so that subscribers can use the phone as a recording and playback device in Cisco Unity web applications and e-mail clients. Assign TRAP Connection to the least busy ports.

Step 6 Click **Save**.

Step 7 Exit UTIM.

Testing the Integration

To test whether Cisco Unity and the phone system are integrated correctly, do the following procedures in the order listed.

If any of the steps indicate a failure, refer to the following documentation as applicable:

- The installation guide for the phone system.
- *Cisco Unity Troubleshooting Guide*, available at http://www.cisco.com/en/US/products/sw/voicesw/ps2237/prod_troubleshooting_guides_list.html.
- The setup information earlier in this guide.

To Set Up the Test Configuration

Step 1 Set up two test extensions (Phone 1 and Phone 2) on the same phone system that Cisco Unity is connected to.

Step 2 Set Phone 1 to forward calls to the Cisco Unity pilot number when calls are not answered.



Caution The phone system must forward calls to the Cisco Unity pilot number in no fewer than four rings. Otherwise, the test may fail.

Step 3 In the Cisco Unity Administrator, create a test subscriber to use for testing by doing the applicable substeps below.

If your message store is Microsoft Exchange, do the following:

- a. In the Cisco Unity Administrator, go to the **Subscribers > Subscribers > Profile** page.
- b. Click the **Add** icon.
- c. In the New subscriber field, click **Exchange**.
- d. On the Add Subscriber page, enter the applicable information.
- e. Click **Add**.

If your message store is IBM Lotus Domino, do the following:

- a. In the Cisco Unity Administrator, go to the **Subscribers > Subscribers > Profile** page.
- b. Click the **Add** icon.
- c. In the New Subscriber field, click **Notes**.
- d. In the Address Book list, confirm that the address book listed is the one that contains the user data that you want to import.

If the address book that you want to use is not listed, go to the **System > Configuration > Subscriber Address Books** page and add a different address book.
- e. In the Find Domino Person By list, indicate whether to search by short name, first name, or last name.
- f. Enter the applicable short name or name. You also can enter * to display a list of all users, or enter one or more characters followed by * to narrow your search.
- g. Click **Find**.
- h. On the list of matches, click the name of the user to import.
- i. On the Add Subscriber page, enter the applicable information.
- j. Click **Add**.

Step 4 In the Extension field, enter the extension of Phone 1.

Step 5 In the Active Schedule field, click **All Hours - All Days**.

Step 6 Click the **Save** icon.

Step 7 In the navigation bar, click **Call Transfer** to go to the Subscribers > Subscribers > Call Transfer page for the test subscriber.

For more information on transfer settings, refer to the “Subscriber Template Call Transfer Settings” section in the Cisco Unity Administrator Help.

Step 8 In the Transfer Rule Applies To field, click **Standard**.

- Step 9** Under Transfer Incoming Calls, click **Yes, Ring Subscriber's Extension**, and confirm that the extension number is for Phone 1.
- Step 10** Under Transfer Type, click **Release to Switch**.
- Step 11** Click the **Save** icon.
- Step 12** In the navigation bar, click **Messages** to go to the Subscribers > Subscribers > Messages page for the test subscriber.
- Step 13** Under Message Waiting Indicators (MWIs), check **Use MWI for Message Notification**.
- Step 14** In the Extension field, enter **x**.
- Step 15** Click the **Save** icon.
- Step 16** Open the Status Monitor by doing one of the following:
- In Internet Explorer, go to **http://<Cisco Unity server name>/web/sm**.
 - Double-click the desktop shortcut to the Status Monitor.
 - In the status bar next to the clock, right-click the Cisco Unity tray icon and click **Status Monitor**.
-

To Test an External Call with Release Transfer

- Step 1** From Phone 2, enter the access code necessary to get an outside line, then enter the number outside callers use to dial directly to Cisco Unity.
- Step 2** On the Status Monitor, note which port handles this call.
- Step 3** When you hear the opening greeting, enter the extension for Phone 1. Hearing the opening greeting means that the port is configured correctly.
- Step 4** Confirm that Phone 1 rings and that you hear a ringback tone on Phone 2. Hearing a ringback tone means that Cisco Unity correctly released the call and transferred it to Phone 1.
- Step 5** Leaving Phone 1 unanswered, confirm that the state of the port handling the call changes to "Idle." This state means that release transfer is successful.
- Step 6** Confirm that, after the number of rings that the phone system is set to wait, the call is forwarded to Cisco Unity and that you hear the greeting for the test subscriber. Hearing the greeting means that the phone system forwarded the unanswered call and the call-forward information to Cisco Unity, which correctly interpreted the information.
- Step 7** On the Status Monitor, note which port handles this call.
- Step 8** Leave a message for the test subscriber and hang up Phone 2.
- Step 9** On the Status Monitor, confirm that the state of the port handling the call changes to "Idle." This state means that the port was successfully released when the call ended.
- Step 10** Confirm that the MWI on Phone 1 is activated. The activated MWI means that the phone system and Cisco Unity are successfully integrated for turning on MWIs.
-

To Test Listening to Messages

- Step 1** From Phone 1, enter the internal pilot number for Cisco Unity.

- Step 2** When asked for your password, enter the default password. Hearing the request for your password means that the phone system sent the necessary call information to Cisco Unity, which correctly interpreted the information.
 - Step 3** Confirm that you hear the recorded voice name for the test subscriber (if you did not record a voice name for the test subscriber, you will hear the extension number for Phone 1). Hearing the voice name means that Cisco Unity correctly identified the subscriber by the extension.
 - Step 4** When asked whether you want to listen to your message, press **1**.
 - Step 5** After listening to the message, press **3** to delete the message.
 - Step 6** Confirm that the MWI on Phone 1 is deactivated. The deactivated MWI means that the phone system and Cisco Unity are successfully integrated for turning off MWIs.
 - Step 7** Hang up Phone 1.
 - Step 8** On the Status Monitor, confirm that the state of the port handling the call changes to “Idle.” This state means that the port was successfully released when the call ended.
-

To Set Up Supervised Transfer on Cisco Unity

- Step 1** In the Cisco Unity Administrator, go to the **Subscribers > Subscribers > Call Transfer** page.
If the name of the test subscriber is not displayed, click the **Find** icon (the magnifying glass) in the title bar, then click **Find**, and select the name of the test subscriber in the list that appears.
For more information on transfer settings, refer to the “Subscriber Template Call Transfer Settings” section in the Cisco Unity Administrator Help.
 - Step 2** Under Transfer Type, click **Supervise Transfer**.
 - Step 3** Set the Rings to Wait For field to **3**.
 - Step 4** Click the **Save** icon.
-

To Test Supervised Transfer

- Step 1** From Phone 2, enter the access code necessary to get an outside line, then enter the number outside callers use to dial directly to Cisco Unity.
- Step 2** On the Status Monitor, note which port handles this call.
- Step 3** When you hear the opening greeting, enter the extension for Phone 1. Hearing the opening greeting means that the port is configured correctly.
- Step 4** Confirm that Phone 1 rings and that you do not hear a ringback tone on Phone 2. Instead, you should hear the indication your phone system uses to mean that the call is on hold (for example, music or beeps).
- Step 5** Leaving Phone 1 unanswered, confirm that the state of the port handling the call remains “Busy.” This state and hearing an indication that you are on hold mean that Cisco Unity is supervising the transfer.
- Step 6** Confirm that, after three rings, you hear the greeting for the test subscriber. Hearing the greeting means that Cisco Unity successfully recalled the supervised-transfer call.
- Step 7** During the greeting, hang up Phone 2.

- Step 8** On the Status Monitor, confirm that the state of the port handling the call changes to “Idle.” This state means that the port was successfully released when the call ended.
-

To Delete the Test Subscriber

- Step 1** In the Cisco Unity Administrator, go to the **Subscribers > Subscribers > Profile** page.
If the name of the test subscriber is not displayed, click the **Find** icon (the magnifying glass) in the title bar, then click **Find**, and select the name of the test subscriber in the list that appears.
- Step 2** In the title bar, click the **Delete Subscriber** icon (the X).
- Step 3** Click **Delete**.
- Step 4** When prompted to confirm deleting the subscriber, click **OK**.
-

Integrating a Secondary Server for Cisco Unity Failover

The Cisco Unity failover feature enables a secondary server to provide voice messaging services when the primary server becomes inactive. For information on installing a secondary server for failover, refer to the applicable Cisco Unity installation guide, available at

http://www.cisco.com/en/US/products/sw/voicesw/ps2237/prod_installation_guides_list.html.

For information on failover, refer to the applicable *Cisco Unity Failover Configuration and Administration Guide* at

http://www.cisco.com/en/US/products/sw/voicesw/ps2237/products_feature_guides_list.html.

Requirements

The following components are required to integrate a secondary server:

- One secondary server for each primary server installed and ready for the integration, as described in the applicable Cisco Unity installation guide and earlier in this integration guide.
- The applicable cable configuration for each analog voice messaging port to simultaneously connect the phone system to the corresponding ports on both the primary and the secondary servers. For example, connect port 1 on the phone system with both port 1 on the primary server and port 1 on the secondary server.
- A license that enables failover.

Integration Description

The phone system communicates with both the primary and secondary servers through the connecting cables. [Figure 2](#) shows the required connections.

Figure 2 Connections Between the Phone System and Cisco Unity Servers

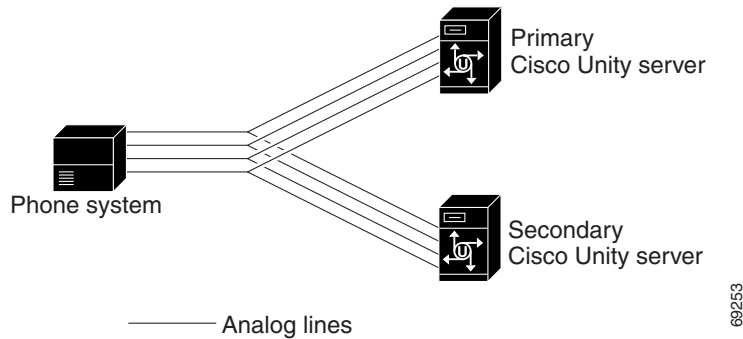

The primary and secondary servers act in the following manner:

- When the primary server is operating normally, the secondary server is inactive.
- When the primary server becomes inactive, the secondary server becomes active.
- When the primary server becomes active again, the secondary server becomes inactive.

Setting Up the Secondary Server for Failover

Do the following procedure to integrate the secondary server.

To Set Up the Secondary Server for Failover

-
- Step 1** Install a secondary server with the same configuration as the primary server. For installation instructions, refer to the applicable Cisco Unity installation guide.
- Step 2** Make all voice connections from the phone system to the corresponding ports on both the primary server and the secondary server. For example, connect port 1 from the phone system with port 1 on both the primary and the secondary servers.
- Step 3** On the Windows Start menu of the secondary server, click **Programs > Cisco Unity > Manage Integrations**. The UTIM window appears.
- Step 4** On the Integration menu of the UTIM window, click **New**. The Telephony Integration Setup Wizard appears.
- Step 5** Enter the settings to match the integration settings on the primary server.



Note We recommend not reassigning any unassigned subscribers and call handlers to the new integration, if you are asked by the wizard. Failover replication will automatically assign the correct integration.

- Step 6** At the prompt to restart the Cisco Unity services, click **Yes**.



Note When restarting the Cisco Unity services, use the UTIM prompt instead of the Cisco Unity icon in the Windows taskbar. The taskbar icon does not restart all of the Cisco Unity services.

- Step 7** After Cisco Unity restarts, on the Windows Start menu of the Cisco Unity server, click **Programs > Cisco Unity > Manage Integrations**. UTIM appears.

- Step 8** In the left pane of the UTIM window, click the phone system integration that you created in [Step 4](#).
- Step 9** In the right pane, click **Properties**.
- Step 10** On the Integration tab, compare the setting of the Integration ID field for the secondary server to the setting of the Integration ID field for the primary server.
- Step 11** If the integration IDs of the phone system on the primary and secondary server are the same, continue to [Step 17](#).
- If the integration IDs of the phone system on the primary and secondary servers are different, on the secondary server, click **Modify Integration ID**.
- Step 12** When cautioned that subscribers associated with the current Integration ID setting will not be automatically associated with the new Integration ID setting, click **OK**.
- Step 13** In the Modify Integration ID dialog box, in the Enter New Integration ID field, enter the Integration ID setting for the phone system on the primary server and click **OK**.
- Step 14** Click **Save**.
- Step 15** At the prompt to restart the Cisco Unity services, click **No**.
- Step 16** In the left pane, click the phone system integration that you created in [Step 4](#).
- Step 17** In the right pane, click the **Ports** tab.
- Step 18** Enter the port settings to match the port settings on the primary server.

**Caution**

In programming the phone system, do not send calls to voice messaging ports in Cisco Unity that cannot answer calls (voice messaging ports that are not set to Answer Calls). For example, if a voice messaging port is set only to Dialout MWI, do not send calls to it.

- Step 19** Click **Save**.
- Step 20** Exit UTIM.
- Step 21** On the Windows Start menu of the server, click **Programs > Cisco Unity > Edit Switch Utility**.
- Step 22** In the Switch Configuration Editor window, in the Manufacturer field, click **Matra**.
- Step 23** In the Model field, click **6500**.
- Step 24** Click **Edit**.
- Step 25** In the Switch Configuration dialog box, click the **Incoming Calls** tab.
- Step 26** In the Call Rings field, enter **3** and click **OK**.
- Step 27** In the Switch Configuration Editor dialog box, click **Exit**.
- Step 28** On the Windows Start menu, click **Run**.
- Step 29** Enter **Regedit** and click **OK**.

**Caution**

Changing the wrong registry key or entering an incorrect value can cause the server to malfunction. Before you edit the registry, confirm that you know how to restore it if a problem occurs. (Refer to the “Restoring” topics in Registry Editor Help.) If you have any questions about changing registry key settings, contact Cisco TAC.

- Step 30** If you do not have a current backup of the registry, click **Registry > Export Registry File**, and save the registry settings to a file.
- Step 31** Expand the key HKEY_LOCAL_MACHINE\Software\Active Voice\Miu\1.0\Initialization.

- Step 32** Double-click **New Call Delay on Inactive Backup Server**.
- Step 33** In the Edit DWORD Value dialog box, in the Value Data field, enter **0**, and click **OK**.
- Step 34** Close the Registry Editor.
- Step 35** Restart the Cisco Unity server.

No changes to the hunt group programming on the phone system are necessary.

Appendix: Documentation and Technical Assistance

Conventions

The *Matra 6500 DTMF Integration Guide for Cisco Unity 5.0* uses the following conventions.

Table 12 *Matra 6500 DTMF Integration Guide for Cisco Unity 5.0 Conventions*

Convention	Description
boldfaced text	Boldfaced text is used for: <ul style="list-style-type: none"> Key and button names. (Example: Click OK.) Information that you enter. (Example: Enter Administrator in the User Name box.)
< > (angle brackets)	Angle brackets are used around parameters for which you supply a value. (Example: In the Command Prompt window, enter ping <IP address> .)
- (hyphen)	Hyphens separate keys that must be pressed simultaneously. (Example: Press Ctrl-Alt-Delete .)
> (right angle bracket)	A right angle bracket is used to separate selections that you make: <ul style="list-style-type: none"> On menus. (Example: On the Windows Start menu, click Settings > Control Panel > Phone and Modem Options.) In the navigation bar of the Cisco Unity Administrator. (Example: Go to the System > Configuration > Settings page.)
[x] (square brackets)	Square brackets enclose an optional element (keyword or argument). (Example: [reg-e164])
[x y] (vertical line)	Square brackets enclosing keywords or arguments separated by a vertical line indicate an optional choice. (Example: [transport tcp transport udp])
{x y} (braces)	Braces enclosing keywords or arguments separated by a vertical line indicate a required choice. (Example: {tcp udp})

The *Matra 6500 DTMF Integration Guide for Cisco Unity 5.0* also uses the following conventions:

**Note**

Means *reader take note*. Notes contain helpful suggestions or references to material not covered in the document.

**Caution**

Means *reader be careful*. In this situation, you might do something that could result in equipment damage or loss of data.

For descriptions and URLs of Cisco Unity documentation on Cisco.com, see the *About Cisco Unity Documentation*. The document is shipped with Cisco Unity and is available at http://www.cisco.com/en/US/products/sw/voicesw/ps2237/products_documentation_roadmaps_list.html.

Obtaining Documentation, Obtaining Support, and Security Guidelines

For information on obtaining documentation, obtaining support, providing documentation feedback, security guidelines, and also recommended aliases and general Cisco documents, see the monthly *What's New in Cisco Product Documentation*, which also lists all new and revised Cisco technical documentation, at:

<http://www.cisco.com/en/US/docs/general/whatsnew/whatsnew.html>

CCVP, the Cisco logo, and Welcome to the Human Network are trademarks of Cisco Systems, Inc.; Changing the Way We Work, Live, Play, and Learn is a service mark of Cisco Systems, Inc.; and Access Registrar, Aironet, Catalyst, CCDA, CCDP, CCIE, CCIP, CCNA, CCNP, CCSP, Cisco, the Cisco Certified Internetwork Expert logo, Cisco IOS, Cisco Press, Cisco Systems, Cisco Systems Capital, the Cisco Systems logo, Cisco Unity, Enterprise/Solver, EtherChannel, EtherFast, EtherSwitch, Fast Step, Follow Me Browsing, FormShare, GigaDrive, HomeLink, Internet Quotient, IOS, iPhone, IP/TV, iQ Expertise, the iQ logo, iQ Net Readiness Scorecard, iQuick Study, LightStream, Linksys, MeetingPlace, MGX, Networkers, Networking Academy, Network Registrar, PIX, ProConnect, ScriptShare, SMARTnet, StackWise, The Fastest Way to Increase Your Internet Quotient, and TransPath are registered trademarks of Cisco Systems, Inc. and/or its affiliates in the United States and certain other countries.

All other trademarks mentioned in this document or Website are the property of their respective owners. The use of the word partner does not imply a partnership relationship between Cisco and any other company. (0711R)

Any Internet Protocol (IP) addresses used in this document are not intended to be actual addresses. Any examples, command display output, and figures included in the document are shown for illustrative purposes only. Any use of actual IP addresses in illustrative content is unintentional and coincidental.

© 2007 Cisco Systems, Inc. All rights reserved.

