



# Intecom E14 Millennium Serial Integration Guide for Cisco Unity 5.0

---

*Revised November 26, 2007*

This document provides instructions for integrating the phone system with Cisco Unity.

## Integration Tasks

Before doing the following tasks to integrate Cisco Unity with the Intecom E14 Millennium phone system, confirm that the Cisco Unity server is ready for the integration by completing the applicable tasks in the applicable Cisco Unity installation guide.

The following task list describes the process for creating the integration.

## Task List to Create the Integration

Use the following task list to set up a new integration with the Intecom E14 Millennium phone system. If you are installing a new Cisco Unity server by using the applicable Cisco Unity installation guide, you may have already completed some of the following tasks.

1. Review the system and equipment requirements to confirm that all phone system and Cisco Unity server requirements have been met. See the [“Requirements” section on page 2](#).
2. Plan how the voice messaging ports will be used by Cisco Unity. See the [“Planning How the Voice Messaging Ports Will Be Used by Cisco Unity” section on page 4](#).
3. Program the Intecom E14 Millennium phone system and extensions. See the [“Programming the Intecom E14 Millennium Phone System” section on page 6](#).
4. Create the integration. See the [“Creating a New Integration with the Intecom E14 Millennium Phone System” section on page 8](#).
5. Test the integration. See the [“Testing the Integration” section on page 12](#).
6. If you have a secondary server for Cisco Unity failover, integrate the secondary server. See the [“Integrating a Secondary Server for Cisco Unity Failover” section on page 16](#).



---

**Americas Headquarters:**  
**Cisco Systems, Inc., 170 West Tasman Drive, San Jose, CA 95134-1706 USA**

© 2007 Cisco Systems, Inc. All rights reserved.

# Requirements

The Intecom E14 Millennium integration supports configurations of the following components:

## Phone System

- Intecom E14 Millennium.
- Software version 11.2 or later.
- A port on the ITE line card connected with a digital line to a PDI-1000/DCE, which in turn is connected to a serial port (COM1 is the default) on the Cisco Unity server with an RS-232 serial cable.

We recommend that the serial cable have the following construction:

- A maximum of 50 feet (15.24 m) in length
  - 24 AWG stranded conductors
  - Low capacitance—for example, no more than 12 pF/ft (39.4 pF/m) between conductors
  - At least 65 percent braided shield over aluminized polymer sleeve around conductors
  - UL-recognized overall cable jacket insulation with low dielectric constant
  - Braided shield fully terminated to and enclosed by a metal connector backshell
  - Gold-plated connector contacts
- A T1/IXL card installed in the Interface Shelf, connected to the voice cards in the Cisco Unity server.
  - The phone system ready for the integration as described in the installation guide for the phone system.

## Cisco Unity Server

- The applicable voice cards, installed. For details, refer to the “Supported Circuit-Switched Phone System Integrations” section in the applicable *Supported Hardware and Software, and Support Policies* at [http://www.cisco.com/en/US/products/sw/voicesw/ps2237/prod\\_installation\\_guides\\_list.html](http://www.cisco.com/en/US/products/sw/voicesw/ps2237/prod_installation_guides_list.html).
- Cisco Unity installed and ready for the integration, as described in the applicable Cisco Unity installation guide at [http://www.cisco.com/en/US/products/sw/voicesw/ps2237/prod\\_installation\\_guides\\_list.html](http://www.cisco.com/en/US/products/sw/voicesw/ps2237/prod_installation_guides_list.html).
- A license that enables the applicable number of voice messaging ports.
- An available serial port (COM1 is the default).

## Integration Description

The Intecom E14 Millennium integration uses a data link, which consists of a digital line, a PDI-1000/DCE, and an RS-232 serial cable connecting the phone system and the Cisco Unity server. The voice messaging lines from the phone system connect to the T1 voice cards in the Cisco Unity server. [Figure 1](#) shows the required connections.

**Figure 1** T1 Connections Between the Phone System and Cisco Unity

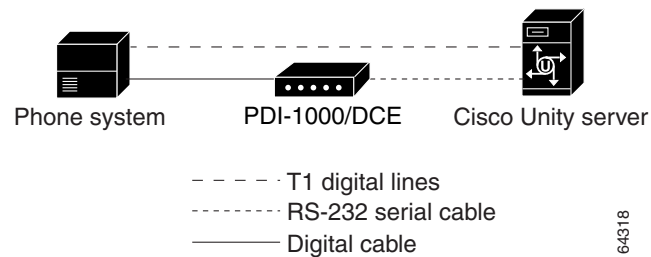

## Call Information

The phone system sends the following information through the data link:

- The extension of the called party
- The extension of the calling party (for internal calls) or the phone number of the calling party (if it is an external call and the system uses caller ID)
- The reason for the forward (the extension is busy, does not answer, or is set to forward all calls)

Cisco Unity uses this information to answer the call appropriately. For example, a call forwarded to Cisco Unity is answered with the personal greeting of the subscriber. If the phone system routes the call to Cisco Unity without this information, Cisco Unity answers with the opening greeting.

## Integration Functionality

The Intecom E14 Millennium integration with Cisco Unity provides the following integration features:

- Call forward to personal greeting
- Call forward to busy greeting
- Caller ID
- Easy message access (a subscriber can retrieve messages without entering an ID because Cisco Unity identifies the subscriber based on the extension from which the call originated; a password may be required)
- Identified subscriber messaging (Cisco Unity identifies the subscriber who leaves a message during a forwarded internal call, based on the extension from which the call originated)
- Message waiting indication (MWI)

## Integrations with Multiple Phone Systems

Cisco Unity can be integrated with multiple phone systems at one time. For information on the maximum supported combinations and instructions for integrating Cisco Unity with multiple phone systems, refer to the applicable *Multiple Phone System Integration Guide* at [http://www.cisco.com/en/US/products/sw/voicesw/ps2237/products\\_installation\\_and\\_configuration\\_guides\\_list.html](http://www.cisco.com/en/US/products/sw/voicesw/ps2237/products_installation_and_configuration_guides_list.html).

## Planning How the Voice Messaging Ports Will Be Used by Cisco Unity

Before programming the phone system, you need to plan how the voice messaging ports will be used by Cisco Unity. The following considerations will affect the programming for the phone system (for example, setting up the hunt group or call forwarding for the voice messaging ports):

- The number of voice messaging ports installed.
- The number of voice messaging ports that will answer calls.
- The number of voice messaging ports that will only dial out, for example, to send message notification, to set message waiting indicators (MWIs), to make AMIS deliveries, and to make telephone record and playback (TRAP) connections.

The following table describes the voice messaging port settings in Cisco Unity that can be set in UTIM, and that are displayed as read-only text on the System > Ports page of the Cisco Unity Administrator.

**Table 1**      **Settings for the Voice Messaging Ports**

Field	Considerations
Extension	Enter the extension for the port as assigned on the phone system.
Enabled	Check this check box to enable the port. The port is enabled during normal operation. Uncheck this check box to disable the port. When the port is disabled, calls to the port get a ringing tone but are not answered. Typically, the port is disabled only by the installer during testing.
Answer Calls	Check this check box to designate the port for answering calls. These calls can be incoming calls from unidentified callers or from subscribers.
Message Notification	Check this check box to designate the port for notifying subscribers of messages. Assign Message Notification to the least busy ports.
Dialout MWI (not used by serial or SMDI integrations)	Check this check box to designate the port for turning MWIs on and off. Assign Dialout MWI to the least busy ports.

**Table 1**      **Settings for the Voice Messaging Ports (continued)**

Field	Considerations
AMIS Delivery <i>(available with the AMIS licensed feature only)</i>	Check this check box to designate the port for making outbound AMIS calls to deliver voice messages from Cisco Unity subscribers to users on another voice messaging system. Cisco Unity supports the Audio Messaging Interchange Specification (AMIS) protocol, which provides an analog mechanism for transferring voice messages between different voice messaging systems.  This setting affects outbound AMIS calls only. All ports are used for incoming AMIS calls. Because the transmission of outgoing AMIS messages may tie up voice ports for long periods of time, you may want to adjust the schedule on the Network > AMIS > Schedule page so that outgoing AMIS calls are placed during closed hours or at times when Cisco Unity is not processing many calls.
TRAP Connection	Check this check box so that subscribers can use the phone as a recording and playback device in Cisco Unity web applications and e-mail clients. Assign TRAP Connection to the least busy ports.

### The Number of Voice Messaging Ports to Install

The number of voice messaging ports to install depends on numerous factors, including:

- The number of calls Cisco Unity will answer when call traffic is at its peak.
- The expected length of each message that callers will record and that subscribers will listen to.
- The number of subscribers.
- The number of ports that will be set to dial out only.
- The number of calls made for message notification.
- The number of MWIs that will be activated when call traffic is at its peak.
- The number of AMIS delivery calls.
- The number of TRAP connections needed when call traffic is at its peak. (TRAP connections are used by Cisco Unity web applications to play back and record over the phone.)
- The number of calls that will use the automated attendant and call handlers when call traffic is at its peak.

It is best to install only the number of voice messaging ports that are needed so that system resources are not allocated to unused ports.

### The Number of Voice Messaging Ports That Will Answer Calls

The calls that the voice messaging ports answer can be incoming calls from unidentified callers or from subscribers. Typically, the voice messaging ports that answer calls are the busiest.

You can set voice messaging ports to both answer calls and to dial out (for example, to send message notifications). However, when the voice messaging ports perform more than one function and are very active (for example, answering many calls), the other functions may be delayed until the voice messaging port is free (for example, message notifications cannot be sent until there are fewer calls to answer). For best performance, dedicate certain voice messaging ports for only answering incoming calls, and dedicate other ports for only dialing out. Separating these port functions eliminates the possibility of a collision, in which an incoming call arrives on a port at the same time that Cisco Unity takes the port off-hook to dial out.

**The Number of Voice Messaging Ports That Will Only Dial Out, and Not Answer Calls**

Ports that will only dial out and will not answer calls can do one or more of the following:

- Notify subscribers by phone, pager, or e-mail of messages that have arrived.
- Turn MWIs on and off for subscriber extensions.
- Make outbound AMIS calls to deliver voice messages from Cisco Unity subscribers to users on another voice messaging system. (This action is available only with the AMIS licensed feature.)
- Make a TRAP connection so that subscribers can use the phone as a recording and playback device in Cisco Unity web applications.

Typically, these voice messaging ports are the least busy ports.

**Caution**

In programming the phone system, do not send calls to voice messaging ports in Cisco Unity that cannot answer calls (voice messaging ports that are not set to Answer Calls). For example, if a voice messaging port is set only to Dialout MWI, do not send calls to it.

**Preparing for Programming the Phone System**

Record your decisions about the voice messaging ports to guide you in programming the phone system.

# Programming the Intecom E14 Millennium Phone System

If you use programming options other than those supplied in the following procedure, the performance of the integration may be affected.

**Caution**

In programming the phone system, do not send calls to voice messaging ports in Cisco Unity that cannot answer calls (voice messaging ports that are not set to Answer Calls). For example, if a voice messaging port is set only to Dialout MWI, do not send calls to it.

Do the following procedure.

**To Program the Intecom E14 Millennium Phone System**

- Step 1** Create a TTY group for the PDI-1000/DCE interface. Use the following settings:
- Asynchronous line type
  - Bisync protocol
  - ASCII coding
  - 1200 baud
  - Even parity
  - 1 stop bit
  - 7 data bits
- Step 2** Assign an ITE data port for the PDI-1000/DCE interface to the TTY group created in [Step 1](#). Make sure that the port type for this ITE data port is **DPRT**.
- Step 3** Use the ILK subcommand of the UTIL command to link this ITE data port to the PBX MCU. For some versions of the Intecom phone system, use the NAIL command to do this step.

**Step 4** Define a two-way universal trunk group for the voice messaging ports. The parameters used for testing the integration are as follows:

```

** TRUNK GROUP DEFINITION      05/09/37  19:34:51
***...TRUNK GROUP.....37
***...TRUNK GROUP TYPE.....UNIVERSAL
TCI...TRUNK CLASS IDENTIFICATION.....FX
UGP...USER GROUP NUMBER.....1
VTT...VOICE TRUNK TRANSFER ENABLED.....YES
CDT...TRANSFER COLLECT DIGIT TABLE #.....NONE
DCS...DEFAULT CLASS OF SERVICE.....1
CNC...NATIONAL CALLING PARTY # CONTENTS..NONE
DCP...DISPLAY CALLING PARTY NUMBER.....YES
PND...PRIVATE NETWORK.....YES
***...LANmark PRI TRUNK GROUP.....NO
ITY...INTEMAIL TYPE.....SMDI - FIXED 7 DIGIT
IST...DOES InteMail SUPERVISE TRANSFERS?.YES
MCT...METHOD TO CANCEL InteMail TRANSFER.FLASH
IML...InteMail USER ID LENGTH.....6
IIN...INTEMAIL INTERFACE NUMBER.....1
VNP...InteMail NUMBER FORMAT.....DIRN
OAM...OAI ASSOCIATED MEMBER.....NO
BTG...BROADCAST TRUNK GROUP.....NO
TCM...TRAVELING CLASSMARK.....NO
FTH...FAILURE THRESHOLD.....3
RDT...RESEIZE DELAY TIME.....MSEC:50
CHT...TRUNK MONITOR MINIMUM HOLD TIME....0
DET...DISTANT END RELEASE TIME.....SEC:60
DCT...DATA CALLS ALLOWED.....NO
SWM...SEIZE WHEN MOS.....YES
TCH...TRUNK CALL HANDLING.....EXTERNAL
NDS...DISCONNECT SUPERVISION.....YES
IGG...IGNORE GLARE.....NO
GDT...GLARE DETECT TIME.....MSEC:100
XFT...DISTANT IBX ALLOWS FEATURE TRANSP..NO
DPT...DTMF PASSTHROUGH TIMING INDEX.....NONE
.....TRUNK DIRECTION.....BOTH WAYS
*** INCOMING PARAMETERS
STY...INCOMING CALL ORIGINATION TYPE....T1 OFF PREM.OPX (OFF PREMISE)
TYP...INCOMING TRUNK TYPE.....DIALED
ICM...INCOMING CALL MESSAGE #.....NONE
IDS...INCOMING DIGIT SEQUENCE.....DESTINATION NUMBER ONLY
IRD...RESPONSE TO DESTINATION NUMBER....NONE
IRC...RESPONSE TO CALLING PARTY NUMBER..NONE
IIT...INCOMING INFO DIGIT TYPE/LENGTH...NONE
BGP...ANNOUNCEMENT BROADCAST TRUNK GROUP.NONE
APA...TRUNK GROUP AUTHORIZATION TYPE....NONE
PVA...PRE-VALIDATE AUTHORIZATION CODE...NO
RSC...RESET COUNT.....1
LVL...PREDEFINED LEVEL CODE.....NONE
TNE...TONE TABLE ENTRY NUMBER.....NONE
MOD...INCOMING DIAL MODE.....DTMF
RGF...DTMF RECEIVER GROUP.....52
TOO...TIMEOUT TO ATTENDANT.....NO
MCL...MULTIPLE CALLING ALLOWED.....NO
RAC...REUSE AUTH FOR MULT. CALLS.....NO
GAC...GROUP AUTH REQUIRED FOR TRUNKS....NO
SAC...SYSTEM ACCESS CODE.....NONE
CWR...CALLWAIT RINGBACK.....NO
UCT...TRUNK UPDATE CDR ON TRANSFER.....ALL
CPT...CALL PROGRESSING TONES:.....IBX PROVIDED
RIO...RESPONSE TO INCOMING ORIGINATION..SEIZE IMMED.
TCT...STATION CALL RESTRICTION ENABLED..NO
8NC...800 TO 4D SPEED NUMBER CONVERSION..NO

```

```

*** OUTGOING PARAMETERS
MSG...MODEM SIGNALLING.....YES
TXA...DIRECT TGRP SELECT ALLOWED.....YES
ATG...ANNOUNCEMENT TRUNK GROUP.....NO
SLC...TRUNK SELECTION.....TOP DOWN
ICA...INTER-LATA CARRIER.....10XXX
CPN...CALLING PARTY NUMBER.....DO NOT SEND

```

**Step 5** Configure the T1 cards to be connected to Cisco Unity for the following:

- Internal clocking
- AMI line coding
- D4 framing

**Step 6** Create appropriate routing for access to the voice mail trunk group.

Make sure that the Cisco Unity subscribers are assigned feature options and class of service options that accommodate voice mail.

**Step 7** Program each phone to forward calls to the pilot number assigned to the voice messaging ports, based on one of the Cisco Unity call transfer types in [Table 2](#).

**Table 2** Call Transfer Types

Transfer type	Usage
Release transfer (blind transfer)	Program the phone to forward calls to the pilot number when: <ul style="list-style-type: none"> <li>• The extension is busy</li> <li>• The call is not answered</li> </ul>
Supervised transfer	Program the phone to forward calls to the pilot number only when the call is not answered. Confirm that call forwarding is disabled when the extension is busy.

## Creating a New Integration with the Intecom E14 Millennium Phone System

After ensuring that the Intecom E14 Millennium phone system and the Cisco Unity server are ready for the integration, do the following procedures to set up the integration and to enter the port settings.

### To Create an Integration

- Step 1** If UTIM is not already open, on the Windows Start menu of the Cisco Unity server, click **Programs > Cisco Unity > Manage Integrations**. UTIM appears.
- Step 2** In the left pane of the UTIM window, click **Cisco Unity Server**.
- Step 3** On the Integration menu of the UTIM window, click **New**. The Telephony Integration Setup Wizard appears.
- Step 4** On the Welcome page, click **Circuit-Switched via Voice Card** and click **Next**.

- Step 5** On the Name the Phone System Integration page, accept the default name or enter the phone system name to identify this integration, then click **Next**.
- Step 6** On the Select Integration Method page, click **Serial**, then click **Next**.
- Step 7** On the Select Phone System Manufacturer page, click the following settings, then click **Next**.

**Table 3** *Settings for the Select Phone System Manufacturer Page*

Field	Setting
Manufacturer	Intecom
Model	E14 Millennium
Software Version	All
Configuration File	<if you have made copies of the .ini configuration file, the name of the configuration file that you want to use>

- Step 8** On the Select Serial Integration Packet Settings page, enter the following settings, then click **Next**.

**Table 4** *Settings for the Select Serial Integration Packet Settings Page*

Field	Setting
Station Field Length	<the station prefix plus the default extension length; accept the default or click another setting; this length is either 10 or 7>
Default Extension Length	<the default length of extensions on the phone system; accept the default or click another setting>

- Step 9** On the Select COM Port Settings page, enter the following settings, then click **Next**.

**Table 5** *Settings for the Select COM Port Settings Page*

Field	Setting
COM Port	<the communications port on the Cisco Unity server that will receive the call information; typically, this setting is 1>
Baud Rate	<the baud rate that the phone system uses>
Data Bits	<the number of data bits that the phone system uses>
Stop Bits	<the number of stop bits that the phone system uses>
Parity	<the parity that the phone system uses>

- Step 10** On the Set Number of Voice Messaging Ports page, enter the number of voice messaging ports on Cisco Unity that you want to connect to the phone system, then click **Next**.
- This number cannot be more than the number of ports on the installed voice cards or the number of ports set up on the phone system.
- Step 11** If other integrations already exist, the Enter Trunk Access Code page appears. Enter the extra digits that Cisco Unity must use to transfer calls through the gateway to extensions on the other phone systems with which it is integrated. Then click **Next**.
- Step 12** On the Reassign Subscribers page, any subscribers whose phone system integration has been deleted and who are not currently assigned to a phone system integration will appear in the list.

If no subscribers appear in the list, click **Next** and continue to [Step 13](#).

Otherwise, select the subscribers that you want to assign to this phone system integration and click **Next**. You can use the following selection controls for selecting subscribers.

**Table 6** Selection Controls for the Reassign Subscribers Page

Selection Control	Effect
Check All	Checks the check boxes for all subscribers in the list.
Uncheck All	Unchecks the check boxes for all subscribers in the list.
Toggle Selected	For the subscribers highlighted in the list, toggles between checking and unchecking the check boxes.  If some highlighted subscriber check boxes are checked and others are unchecked, clicking this button will check all the check boxes. Clicking again will uncheck all the check boxes.

**Step 13** On the Reassign Call Handlers page, any call handlers whose phone system integration has been deleted and that are not currently assigned to a phone system integration will appear in the list.

If no call handlers appear in the list, click **Next** and continue to [Step 14](#).

Otherwise, select the call handlers that you want to assign to this phone system integration and click **Next**. You can use the following selection controls for selecting call handlers.

**Table 7** Selection Controls for the Reassign Call Handlers Page

Selection Control	Effect
Check All	Checks the check boxes for all call handlers in the list.
Uncheck All	Unchecks the check boxes for all call handlers in the list.
Toggle Selected	For the call handlers highlighted in the list, toggles between checking and unchecking the check boxes.  If some highlighted call handler check boxes are checked and others are unchecked, clicking this button will check all the check boxes. Clicking again will uncheck all the check boxes.

**Step 14** On the Completing page, verify the settings you entered, then click **Finish**.

**Step 15** At the prompt to restart the Cisco Unity services, click **Yes**. The Cisco Unity services restart.

Alternatively, you can restart the Cisco Unity services in UTIM on the Tools menu by clicking **Restart Cisco Unity**.

---

### To Enter the Voice Messaging Port Settings for the Integration

---

**Step 1** After the Cisco Unity services restart, on the View menu, click **Refresh**.

**Step 2** In the left pane of the UTIM window, expand the phone system integration that you are creating.

**Step 3** In the left pane, click the name of the phone system.

**Step 4** In the right pane, click the **Ports** tab.

**Step 5** Enter the settings shown in [Table 8](#) for the voice messaging ports.

For best performance, use the first voice messaging ports for incoming calls and the last ports to dial out. This helps minimize the possibility of a collision, in which an incoming call arrives on a port at the same time that Cisco Unity takes the port off-hook to dial out.



**Caution**

In programming the phone system, do not send calls to voice messaging ports in Cisco Unity that cannot answer calls (voice messaging ports that are not set to Answer Calls). For example, if a voice messaging port is set only to Message Notification, do not send calls to it.

**Table 8** Settings for the Voice Messaging Ports

Field	Considerations
Extension	Enter the extension for the port as assigned on the phone system.
Enabled	Check this check box to enable the port. The port is enabled during normal operation. Uncheck this check box to disable the port. When the port is disabled, calls to the port get a ringing tone but are not answered. Typically, the port is disabled only by the installer during testing.
Answer Calls	Check this check box to designate the port for answering calls. These calls can be incoming calls from unidentified callers or from subscribers.
Message Notification	Check this check box to designate the port for notifying subscribers of messages. Assign Message Notification to the least busy ports.
Dialout MWI (not used by serial or SMDI integrations)	Check this check box to designate the port for turning MWIs on and off. Assign Dialout MWI to the least busy ports.
AMIS Delivery (available with the AMIS licensed feature only)	Check this check box to designate the port for making outbound AMIS calls to deliver voice messages from Cisco Unity subscribers to users on another voice messaging system. Cisco Unity supports the Audio Messaging Interchange Specification (AMIS) protocol, which provides an analog mechanism for transferring voice messages between different voice messaging systems.  This setting affects outbound AMIS calls only. All ports are used for incoming AMIS calls. Because the transmission of outgoing AMIS messages may tie up voice ports for long periods of time, you may want to adjust the schedule on the Network > AMIS > Schedule page so that outgoing AMIS calls are placed during closed hours or at times when Cisco Unity is not processing many calls.
TRAP Connection	Check this check box so that subscribers can use the phone as a recording and playback device in Cisco Unity web applications and e-mail clients. Assign TRAP Connection to the least busy ports.

**Step 6** Click **Save**.

**Step 7** Exit UTIM.

If the phone system uses extension numbers that begin with zero (for example, 0123 or 09876), do the following procedure.

Note that after the procedure is done all extension numbers must have the same number of digits. In this case, for example, 0123 and 1234 are both allowed, but 0123 and 234 are not allowed. The extension 234 would be interpreted as 0234.

#### To Enable Extensions Beginning with Zero

- 
- Step 1** On the Windows Start menu, click **Programs > Cisco Unity > Manage Integrations**. UTIM appears.
- Step 2** In the left pane of the UTIM window, click the phone system integration, and click the **Properties** node.
- Step 3** In the right pane of the UTIM window, click the **Integration** tab.
- Step 4** Note the name of the Switch.ini file that appears in the Configuration File field.
- Step 5** Exit UTIM.
- Step 6** On the Windows Start menu, click **Programs > Accessories > Notepad**. The Notepad window appears.
- Step 7** On the File menu, click **Open**.
- Step 8** In the Open dialog box, browse to the \CommServer\IntLib directory, and double-click the name of the Switch.ini file you noted in [Step 4](#).
- Step 9** In the Configuration section of the file, insert the following line:
- ```
AllowZeroLeadingExtensions=1
```
- If the line is already present in the Configuration section, confirm that the final digit is **1**.
- Step 10** Save the file, and exit Notepad.
- Step 11** For the settings to take effect, restart the Cisco Unity server.
- 

## Testing the Integration

To test whether Cisco Unity and the phone system are integrated correctly, do the following procedures in the order listed.

If any of the steps indicate a failure, refer to the following documentation as applicable:

- The installation guide for the phone system.
- *Cisco Unity Troubleshooting Guide*, available at [http://www.cisco.com/en/US/products/sw/voicesw/ps2237/prod\\_troubleshooting\\_guides\\_list.html](http://www.cisco.com/en/US/products/sw/voicesw/ps2237/prod_troubleshooting_guides_list.html).
- The setup information earlier in this guide.

#### To Set Up the Test Configuration

- 
- Step 1** Set up two test extensions (Phone 1 and Phone 2) on the same phone system that Cisco Unity is connected to.
- Step 2** Set Phone 1 to forward calls to the Cisco Unity pilot number when calls are not answered.



**Caution** The phone system must forward calls to the Cisco Unity pilot number in no fewer than four rings. Otherwise, the test may fail.

---

- Step 3** In the Cisco Unity Administrator, create a test subscriber to use for testing by doing the applicable substeps below.
- If your message store is Microsoft Exchange, do the following:
- In the Cisco Unity Administrator, go to the **Subscribers > Subscribers > Profile** page.
  - Click the **Add** icon.
  - In the New subscriber field, click **Exchange**.
  - On the Add Subscriber page, enter the applicable information.
  - Click **Add**.
- If your message store is IBM Lotus Domino, do the following:
- In the Cisco Unity Administrator, go to the **Subscribers > Subscribers > Profile** page.
  - Click the **Add** icon.
  - In the New Subscriber field, click **Notes**.
  - In the Address Book list, confirm that the address book listed is the one that contains the user data that you want to import.  
  
If the address book that you want to use is not listed, go to the **System > Configuration > Subscriber Address Books** page and add a different address book.
  - In the Find Domino Person By list, indicate whether to search by short name, first name, or last name.
  - Enter the applicable short name or name. You also can enter \* to display a list of all users, or enter one or more characters followed by \* to narrow your search.
  - Click **Find**.
  - On the list of matches, click the name of the user to import.
  - On the Add Subscriber page, enter the applicable information.
  - Click **Add**.
- Step 4** In the Extension field, enter the extension of Phone 1.
- Step 5** In the Active Schedule field, click **All Hours - All Days**.
- Step 6** Click the **Save** icon.
- Step 7** In the navigation bar, click **Call Transfer** to go to the Subscribers > Subscribers > Call Transfer page for the test subscriber.  
  
For more information on transfer settings, refer to the “Subscriber Template Call Transfer Settings” section in the Cisco Unity Administrator Help.
- Step 8** In the Transfer Rule Applies To field, click **Standard**.
- Step 9** Under Transfer Incoming Calls, click **Yes, Ring Subscriber’s Extension**, and confirm that the extension number is for Phone 1.
- Step 10** Under Transfer Type, click **Release to Switch**.
- Step 11** Click the **Save** icon.
- Step 12** In the navigation bar, click **Messages** to go to the Subscribers > Subscribers > Messages page for the test subscriber.
- Step 13** Under Message Waiting Indicators (MWIs), check **Use MWI for Message Notification**.
- Step 14** In the Extension field, enter **x**.

- Step 15** Click the **Save** icon.
- Step 16** Open the Status Monitor by doing one of the following:
- In Internet Explorer, go to **http://<Cisco Unity server name>/web/sm**.
  - Double-click the desktop shortcut to the Status Monitor.
  - In the status bar next to the clock, right-click the Cisco Unity tray icon and click **Status Monitor**.
- 

#### To Test an External Call with Release Transfer

---

- Step 1** From Phone 2, enter the access code necessary to get an outside line, then enter the number outside callers use to dial directly to Cisco Unity.
- Step 2** On the Status Monitor, note which port handles this call.
- Step 3** When you hear the opening greeting, enter the extension for Phone 1. Hearing the opening greeting means that the port is configured correctly.
- Step 4** Confirm that Phone 1 rings and that you hear a ringback tone on Phone 2. Hearing a ringback tone means that Cisco Unity correctly released the call and transferred it to Phone 1.
- Step 5** Leaving Phone 1 unanswered, confirm that the state of the port handling the call changes to “Idle.” This state means that release transfer is successful.
- Step 6** Confirm that, after the number of rings that the phone system is set to wait, the call is forwarded to Cisco Unity and that you hear the greeting for the test subscriber. Hearing the greeting means that the phone system forwarded the unanswered call and the call-forward information to Cisco Unity, which correctly interpreted the information.
- Step 7** On the Status Monitor, note which port handles this call.
- Step 8** Leave a message for the test subscriber and hang up Phone 2.
- Step 9** On the Status Monitor, confirm that the state of the port handling the call changes to “Idle.” This state means that the port was successfully released when the call ended.
- Step 10** Confirm that the MWI on Phone 1 is activated. The activated MWI means that the phone system and Cisco Unity are successfully integrated for turning on MWIs.
- 

#### To Test Listening to Messages

---

- Step 1** From Phone 1, enter the internal pilot number for Cisco Unity.
- Step 2** When asked for your password, enter the default password. Hearing the request for your password means that the phone system sent the necessary call information to Cisco Unity, which correctly interpreted the information.
- Step 3** Confirm that you hear the recorded voice name for the test subscriber (if you did not record a voice name for the test subscriber, you will hear the extension number for Phone 1). Hearing the voice name means that Cisco Unity correctly identified the subscriber by the extension.
- Step 4** When asked whether you want to listen to your message, press **1**.
- Step 5** After listening to the message, press **3** to delete the message.
- Step 6** Confirm that the MWI on Phone 1 is deactivated. The deactivated MWI means that the phone system and Cisco Unity are successfully integrated for turning off MWIs.

- Step 7** Hang up Phone 1.
- Step 8** On the Status Monitor, confirm that the state of the port handling the call changes to “Idle.” This state means that the port was successfully released when the call ended.
- 

### To Set Up Supervised Transfer on Cisco Unity

---

- Step 1** In the Cisco Unity Administrator, go to the **Subscribers > Subscribers > Call Transfer** page. If the name of the test subscriber is not displayed, click the **Find** icon (the magnifying glass) in the title bar, then click **Find**, and select the name of the test subscriber in the list that appears. For more information on transfer settings, refer to the “Subscriber Template Call Transfer Settings” section in the Cisco Unity Administrator Help.
- Step 2** Under Transfer Type, click **Supervise Transfer**.
- Step 3** Set the Rings to Wait For field to **3**.
- Step 4** Click the **Save** icon.
- 

### To Test Supervised Transfer

---

- Step 1** From Phone 2, enter the access code necessary to get an outside line, then enter the number outside callers use to dial directly to Cisco Unity.
- Step 2** On the Status Monitor, note which port handles this call.
- Step 3** When you hear the opening greeting, enter the extension for Phone 1. Hearing the opening greeting means that the port is configured correctly.
- Step 4** Confirm that Phone 1 rings and that you do not hear a ringback tone on Phone 2. Instead, you should hear the indication your phone system uses to mean that the call is on hold (for example, music or beeps).
- Step 5** Leaving Phone 1 unanswered, confirm that the state of the port handling the call remains “Busy.” This state and hearing an indication that you are on hold mean that Cisco Unity is supervising the transfer.
- Step 6** Confirm that, after three rings, you hear the greeting for the test subscriber. Hearing the greeting means that Cisco Unity successfully recalled the supervised-transfer call.
- Step 7** During the greeting, hang up Phone 2.
- Step 8** On the Status Monitor, confirm that the state of the port handling the call changes to “Idle.” This state means that the port was successfully released when the call ended.
- 

### To Delete the Test Subscriber

---

- Step 1** In the Cisco Unity Administrator, go to the **Subscribers > Subscribers > Profile** page. If the name of the test subscriber is not displayed, click the **Find** icon (the magnifying glass) in the title bar, then click **Find**, and select the name of the test subscriber in the list that appears.
- Step 2** In the title bar, click the **Delete Subscriber** icon (the X).
- Step 3** Click **Delete**.

**Step 4** When prompted to confirm deleting the subscriber, click **OK**.

---

## Integrating a Secondary Server for Cisco Unity Failover

The Cisco Unity failover feature enables a secondary server to provide voice messaging services when the primary server becomes inactive. For information on installing a secondary server for failover, refer to the applicable Cisco Unity installation guide, available at

[http://www.cisco.com/en/US/products/sw/voicesw/ps2237/prod\\_installation\\_guides\\_list.html](http://www.cisco.com/en/US/products/sw/voicesw/ps2237/prod_installation_guides_list.html).

For information on failover, refer to the applicable *Cisco Unity Failover Configuration and Administration Guide* at

[http://www.cisco.com/en/US/products/sw/voicesw/ps2237/products\\_feature\\_guides\\_list.html](http://www.cisco.com/en/US/products/sw/voicesw/ps2237/products_feature_guides_list.html).

## Requirements

The following components are required to integrate a secondary server:

### Phone System

- A second ITE digital port connected to a PDI-1000/DCE, which in turn is connected to a serial port on the secondary server with an RS-232 serial cable.
- A T1/IXL card installed in the Interface Shelf, connected to the voice cards in the secondary server for each T1/IXL card connected to the primary server.

### Cisco Unity Server

- One secondary server for each primary server installed and ready for the integration, as described in the applicable Cisco Unity installation guide and earlier in this integration guide.
- A license that enables failover.

## Integration Description

The phone system uses two data links to send call information to the primary and secondary servers. The T1 voice messaging lines from the phone system provide voice connectivity to the primary and secondary servers. [Figure 2](#) shows the required connections.

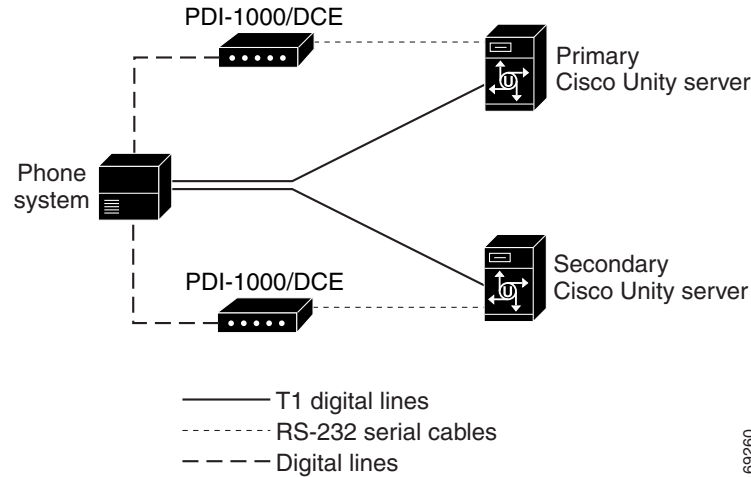
**Figure 2** Connections Between the Phone System and Cisco Unity Servers

69260

**Caution**

It is necessary to either shut down the Dialogic services or disconnect the T1 line to the inactive server before the active server can answer calls.

The primary and secondary servers act in the following manner:

- When the primary server is operating normally, the secondary server is inactive.
- When the primary server becomes inactive, the secondary server becomes active.
- When the primary server becomes active again, the secondary server becomes inactive.

## Setting Up the Secondary Server for Failover

Do the following procedure to integrate the Cisco Unity secondary server.

### To Set Up the Secondary Server for Failover

- Step 1** Install a secondary server with the same configuration as the primary server. For installation instructions, refer to the applicable Cisco Unity installation guide.
- Step 2** Connect the T1 cables from the phone system to the secondary server. The number of T1 cables to the secondary server must match the number of T1 cables to the primary server.
- Step 3** On the phone system, create a second universal trunk group for the voice messaging ports on the secondary server.
- Step 4** Set the universal trunk group for the primary server to send calls to the universal trunk group for the secondary server when the primary server is not active.
- Step 5** Connect a digital cable from a second data port on the phone system to a second PDI-1000/DCE and a second RS-232 serial cable from this PDI-1000/DCE to the primary server.
- Step 6** On the Windows Start menu of the secondary server, click **Programs > Cisco Unity > Manage Integrations**. The UTIM window appears.
- Step 7** On the Integration menu of the UTIM window, click **New**. The Telephony Integration Setup Wizard appears.

**Step 8** Enter the settings to match the integration settings on the primary server.



**Note** We recommend not reassigning any unassigned subscribers and call handlers to the new integration, if you are asked by the wizard. Failover replication will automatically assign the correct integration.

**Step 9** At the prompt to restart the Cisco Unity services, click **Yes**.



**Note** When restarting the Cisco Unity services, use the UTIM prompt instead of the Cisco Unity icon in the Windows taskbar. The taskbar icon does not restart all of the Cisco Unity services.

**Step 10** After Cisco Unity restarts, on the Windows Start menu of the Cisco Unity server, click **Programs > Cisco Unity > Manage Integrations**. UTIM appears.

**Step 11** In the left pane of the UTIM window, click the phone system integration that you created in [Step 7](#).

**Step 12** In the right pane, click **Properties**.

**Step 13** On the Integration tab, compare the setting of the Integration ID field for the secondary server to the setting of the Integration ID field for the primary server.

**Step 14** If the integration IDs of the phone system on the primary and secondary server are the same, continue to [Step 20](#).

If the integration IDs of the phone system on the primary and secondary servers are different, on the secondary server, click **Modify Integration ID**.

**Step 15** When cautioned that subscribers associated with the current Integration ID setting will not be automatically associated with the new Integration ID setting, click **OK**.

**Step 16** In the Modify Integration ID dialog box, in the Enter New Integration ID field, enter the Integration ID setting for the phone system on the primary server and click **OK**.

**Step 17** Click **Save**.

**Step 18** At the prompt to restart the Cisco Unity services, click **No**.

**Step 19** In the left pane, click the phone system integration that you created in [Step 7](#).

**Step 20** In the right pane of the UTIM window, click the **Ports** tab.

**Step 21** Enter the port settings to match the port settings on the primary server.



**Caution** In programming the phone system, do not send calls to voice messaging ports in Cisco Unity that cannot answer calls (voice messaging ports that are not set to Answer Calls). For example, if a voice messaging port is set only to Dialout MWI, do not send calls to it.

**Step 22** Click **Save**.

**Step 23** Exit UTIM.

**Step 24** Click **Programs > Cisco Unity > Edit Switch Utility**.

**Step 25** In the Switch Configuration Editor window, in the Manufacturer field, click **Intecom**.

**Step 26** In the Model field, click **E14 Millennium**.

**Step 27** Click **Edit**.

**Step 28** In the Switch Configuration dialog box, click the **Incoming Calls** tab.

- Step 29** In the Call Rings field, enter **3** and click **OK**.
- Step 30** In the Switch Configuration Editor dialog box, click **Exit**.
- Step 31** On the Windows Start menu, click **Run**.
- Step 32** Enter **Regedit** and click **OK**.



---

**Caution** Changing the wrong registry key or entering an incorrect value can cause the server to malfunction. Before you edit the registry, confirm that you know how to restore it if a problem occurs. (Refer to the “Restoring” topics in Registry Editor Help.) If you have any questions about changing registry key settings, contact Cisco TAC.

---

- Step 33** If you do not have a current backup of the registry, click **Registry > Export Registry File**, and save the registry settings to a file.
- Step 34** Expand the key HKEY\_LOCAL\_MACHINE\Software\Active Voice\Miu\1.0\Initialization.
- Step 35** Double-click **New Call Delay on Inactive Backup Server**.
- Step 36** In the Edit DWORD Value dialog box, in the Value Data field, enter **0**, and click **OK**.
- Step 37** Close the Registry Editor.
- Step 38** Restart the Cisco Unity server.



---

**Caution** It is necessary to either shut down the Dialogic services or disconnect the T1 line to the inactive server before the active server can answer calls.

---

# Appendix: Documentation and Technical Assistance

## Conventions

The *Intecom E14 Millennium Serial Integration Guide for Cisco Unity 5.0* uses the following conventions.

**Table 9** *Intecom E14 Millennium Serial Integration Guide for Cisco Unity 5.0 Conventions*

| Convention                 | Description                                                                                                                                                                                                                                                                                                                                                                                 |
|----------------------------|---------------------------------------------------------------------------------------------------------------------------------------------------------------------------------------------------------------------------------------------------------------------------------------------------------------------------------------------------------------------------------------------|
| boldfaced text             | Boldfaced text is used for: <ul style="list-style-type: none"> <li>• Key and button names. (Example: Click <b>OK</b>.)</li> <li>• Information that you enter. (Example: Enter <b>Administrator</b> in the User Name box.)</li> </ul>                                                                                                                                                        |
| < ><br>(angle brackets)    | Angle brackets are used around parameters for which you supply a value. (Example: In the Command Prompt window, enter <b>ping &lt;IP address&gt;</b> .)                                                                                                                                                                                                                                     |
| -<br>(hyphen)              | Hyphens separate keys that must be pressed simultaneously. (Example: Press <b>Ctrl-Alt-Delete</b> .)                                                                                                                                                                                                                                                                                        |
| ><br>(right angle bracket) | A right angle bracket is used to separate selections that you make: <ul style="list-style-type: none"> <li>• On menus. (Example: On the Windows Start menu, click <b>Settings &gt; Control Panel &gt; Phone and Modem Options</b>.)</li> <li>• In the navigation bar of the Cisco Unity Administrator. (Example: Go to the <b>System &gt; Configuration &gt; Settings</b> page.)</li> </ul> |
| [x]<br>(square brackets)   | Square brackets enclose an optional element (keyword or argument). (Example: [reg-e164])                                                                                                                                                                                                                                                                                                    |
| [x   y]<br>(vertical line) | Square brackets enclosing keywords or arguments separated by a vertical line indicate an optional choice. (Example: [transport tcp   transport udp])                                                                                                                                                                                                                                        |
| {x   y}<br>(braces)        | Braces enclosing keywords or arguments separated by a vertical line indicate a required choice. (Example: {tcp   udp})                                                                                                                                                                                                                                                                      |

The *Intecom E14 Millennium Serial Integration Guide for Cisco Unity 5.0* also uses the following conventions:



### Note

Means *reader take note*. Notes contain helpful suggestions or references to material not covered in the document.

**Caution**

Means *reader be careful*. In this situation, you might do something that could result in equipment damage or loss of data.

For descriptions and URLs of Cisco Unity documentation on Cisco.com, see the *About Cisco Unity Documentation*. The document is shipped with Cisco Unity and is available at [http://www.cisco.com/en/US/products/sw/voicesw/ps2237/products\\_documentation\\_roadmaps\\_list.html](http://www.cisco.com/en/US/products/sw/voicesw/ps2237/products_documentation_roadmaps_list.html).

## Obtaining Documentation, Obtaining Support, and Security Guidelines

For information on obtaining documentation, obtaining support, providing documentation feedback, security guidelines, and also recommended aliases and general Cisco documents, see the monthly *What's New in Cisco Product Documentation*, which also lists all new and revised Cisco technical documentation, at:

<http://www.cisco.com/en/US/docs/general/whatsnew/whatsnew.html>

CCVP, the Cisco logo, and Welcome to the Human Network are trademarks of Cisco Systems, Inc.; Changing the Way We Work, Live, Play, and Learn is a service mark of Cisco Systems, Inc.; and Access Registrar, Aironet, Catalyst, CCDA, CCDP, CCIE, CCIP, CCNA, CCNP, CCSP, Cisco, the Cisco Certified Internetwork Expert logo, Cisco IOS, Cisco Press, Cisco Systems, Cisco Systems Capital, the Cisco Systems logo, Cisco Unity, Enterprise/Solver, EtherChannel, EtherFast, EtherSwitch, Fast Step, Follow Me Browsing, FormShare, GigaDrive, HomeLink, Internet Quotient, IOS, iPhone, IP/TV, iQ Expertise, the iQ logo, iQ Net Readiness Scorecard, iQuick Study, LightStream, Linksys, MeetingPlace, MGX, Networkers, Networking Academy, Network Registrar, PIX, ProConnect, ScriptShare, SMARTnet, StackWise, The Fastest Way to Increase Your Internet Quotient, and TransPath are registered trademarks of Cisco Systems, Inc. and/or its affiliates in the United States and certain other countries.

All other trademarks mentioned in this document or Website are the property of their respective owners. The use of the word partner does not imply a partnership relationship between Cisco and any other company. (0711R)

Any Internet Protocol (IP) addresses used in this document are not intended to be actual addresses. Any examples, command display output, and figures included in the document are shown for illustrative purposes only. Any use of actual IP addresses in illustrative content is unintentional and coincidental.

© 2007 Cisco Systems, Inc. All rights reserved.

