



Avaya Definity Gx/PBXLink Integration Guide for Cisco Unity 5.0

Revised November 26, 2007

This document provides instructions for integrating the phone system with Cisco Unity.

Integration Tasks

Before doing the following tasks to integrate Cisco Unity with the Avaya Definity/PBXLink phone system, confirm that the Cisco Unity server is ready for the integration by completing the applicable tasks in the applicable Cisco Unity installation guide.

The following task list describes the process for creating the integration.

Task List to Create the Integration

Use the following task list to set up a new integration with the Avaya Definity/PBXLink phone system. If you are installing a new Cisco Unity server by using the applicable Cisco Unity installation guide, you may have already completed some of the following tasks.

1. Review the system and equipment requirements to confirm that all phone system and Cisco Unity server requirements have been met. See the [“Requirements” section on page 2](#).
2. Plan how the voice messaging ports will be used by Cisco Unity. See the [“Planning How the Voice Messaging Ports Will Be Used by Cisco Unity” section on page 5](#).
3. Program the Avaya Definity/PBXLink phone system and extensions. See the [“Programming the Avaya Definity/PBXLink Phone System” section on page 7](#).
4. Install and configure the PBXLink box. See the [“Setting Up the PBXLink Box” section on page 19](#).
5. Create the integration. See the [“Creating a New Integration with the Avaya Definity/PBXLink Phone System” section on page 32](#).
6. Test the integration. See the [“Testing the Integration” section on page 36](#).
7. If you have a secondary server for Cisco Unity failover, integrate the secondary server. See the [“Integrating a Secondary Server for Cisco Unity Failover” section on page 39](#).



Americas Headquarters:
Cisco Systems, Inc., 170 West Tasman Drive, San Jose, CA 95134-1706 USA

© 2007 Cisco Systems, Inc. All rights reserved.

Requirements

The Avaya Definity/PBXLink integration supports configurations of the following components:

Phone System

- An Avaya Definity phone system with one or two digital lines connected to the PBX ports on the PBXLink box. The line or lines must be compatible with the 7434D or 8434D digital phones. If vectoring will be used and depending on the phone system, the line or lines may require compatibility with only the 7434D digital phone.
- Bridged mode feature, enabled.
- For each voice messaging port, one analog port connected to the voice cards in the Cisco Unity server.
- The SMDI port in the PBXLink box connected to a serial port (COM1 is the default) on the Cisco Unity server with an RS-232 serial cable. If multiple PBXLink boxes are installed, the SMDI port of the last PBXLink box is connected to the Management port of the first PBXLink box with an RS-232 serial cable. The SMDI port of the first PBXLink box is connected to a serial port (COM1 is the default) on the Cisco Unity server with another RS-232 serial cable. Make sure that the serial protocol parameters for the Management port of the first PBXLink box are set to the same values as the SMDI port.

We recommend that the serial cable have the following construction:

- A maximum of 50 feet (15.24 m) in length
 - 24 AWG stranded conductors
 - Low capacitance—for example, no more than 12 pF/ft (39.4 pF/m) between conductors
 - At least 65 percent braided shield over aluminized polymer sleeve around conductors
 - UL-recognized overall cable jacket insulation with low dielectric constant
 - Braided shield fully terminated to and enclosed by a metal connector backshell
 - Gold-plated connector contacts
- The phone system ready for the integration as described in the installation guide for the phone system.

Cisco Unity Server

- The applicable voice cards, installed. For details, refer to the “Supported Circuit-Switched Phone System Integrations” section in the applicable *Supported Hardware and Software, and Support Policies* at http://www.cisco.com/en/US/products/sw/voicesw/ps2237/prod_installation_guides_list.html.
- Cisco Unity installed and ready for the integration, as described in the applicable Cisco Unity installation guide at http://www.cisco.com/en/US/products/sw/voicesw/ps2237/prod_installation_guides_list.html.
- A license that enables the applicable number of voice messaging ports.
- An available serial port (COM1 is the default).

Integration Description

The Avaya Definity/PBXLink integration uses one or more PBXLink boxes, with each box emulating up to two Avaya 7434D or 8434D digital phones. The PBXLink is connected to the phone system with digital phone lines and connected to the Cisco Unity server with an RS-232 serial cable. The voice messaging lines from the phone system connect to the analog voice cards in the Cisco Unity server.

This integration requires that bridged mode be used.

The PBXLink box receives the following call information from the phone system:

- The extension of the called party
- The extension of the calling party (for internal calls) or the phone number of the calling party (if it is an external call and the system uses caller ID)
- The reason for the forward (the extension is busy, does not answer, or is set to forward all calls)

The PBXLink box formats this information as a Simplified Message Desk Interface (SMDI) packet and sends the packet to Cisco Unity through the RS-232 serial cable.

Cisco Unity uses this information to answer the call appropriately. For example, a call forwarded to Cisco Unity is answered with the personal greeting of the subscriber. If the phone system routes the call to Cisco Unity without this information, Cisco Unity answers with the opening greeting.

Cisco Unity also activates or deactivates messaging waiting indicators (MWIs) through the analog voice messaging ports rather than through the serial data link as in other serial integrations. As a result, it is necessary to set some voice messaging ports for handling MWIs as described in the [“Planning How the Voice Messaging Ports Will Be Used by Cisco Unity”](#) section on page 5, and to enter the MWI on and off codes as described in the [“Creating a New Integration with the Avaya Definity/PBXLink Phone System”](#) section on page 32.

For additional information on the PBXLink box, refer to the PBXLink documentation, which is available from the manufacturer.

Configuration for 24 or Fewer Ports

Avaya Definity/PBXLink integrations with 24 or fewer ports can use the following configuration (others are possible):

- (Recommended) A single PBXLink-24 box with Port A set for calls only.

Configuration for 25 to 48 Ports

Avaya Definity/PBXLink integrations with 25 to 48 ports can use one of the following configurations (others are possible):

- (Recommended) A single PBXLink-48 box with Ports A and B set for calls only.
- Two PBXLink-24 boxes with Port A of both set for calls only.

Configuration for 49 to 72 Ports

Avaya Definity/PBXLink integrations with 49 to 72 ports can use one of the following configurations (others are possible):

- (Recommended) One PBXLink-24 box with Port A set for calls only, and one PBXLink-48 box with Ports A and B set for calls only.
- Two PBXLink-48 boxes with Ports A and Port B of both set for calls only.
- Three PBXLink-24 boxes with Port A of all three set for calls only.

PBXLink Box Connections

A single PBXLink box is connected to the phone system with one or two digital phone lines and connected to the Cisco Unity server with an RS-232 serial cable. The voice messaging lines from the phone system connect to the analog voice cards in the Cisco Unity server. [Figure 1](#) shows the required connections.

Figure 1 Serial Connections Between a Single PBXLink Box and Cisco Unity

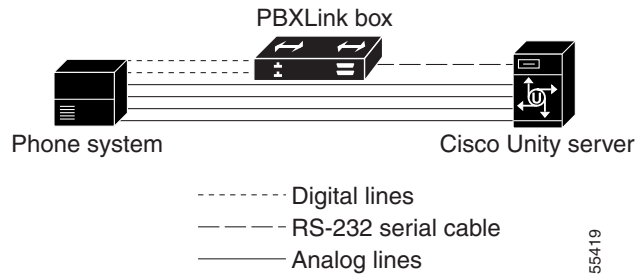

Multiple PBXLink boxes are connected to the Cisco Unity server by using an RS-232 cable to connect the SMDI port from the last PBXLink box to the Management port of the first PBXLink box. Another RS-232 cable is then used to connect the SMDI port of the first PBXLink box to the Cisco Unity server. The voice messaging lines from the phone system connect to the analog voice cards in the Cisco Unity server. [Figure 2](#) shows the required connections.

Figure 2 Serial Connections Between Multiple PBXLink Boxes and Cisco Unity

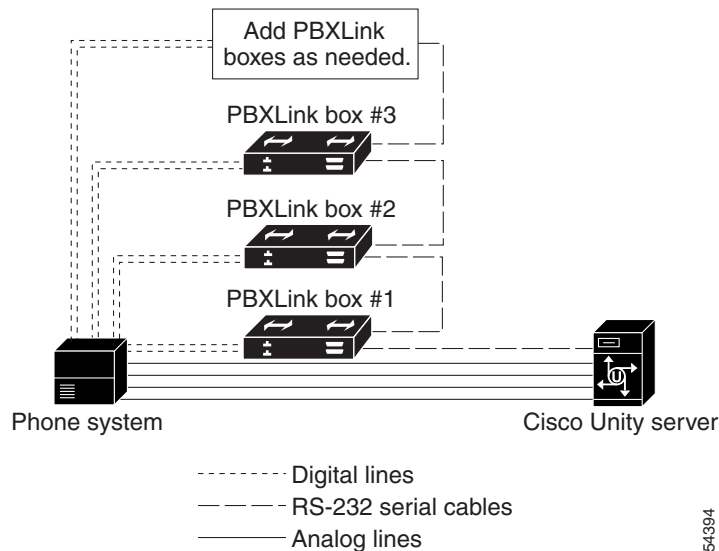

Integration Functionality

The Avaya Definity/PBXLink integration with Cisco Unity provides the following integration features:

- Call forward to personal greeting
- Call forward to busy greeting

- Caller ID
- Easy message access (a subscriber can retrieve messages without entering an ID because Cisco Unity identifies the subscriber based on the extension from which the call originated; a password may be required)
- Identified subscriber messaging (Cisco Unity identifies the subscriber who leaves a message during a forwarded internal call, based on the extension from which the call originated)
- Message waiting indication (MWI)

Integrations with Multiple Phone Systems

Cisco Unity can be integrated with multiple phone systems at one time. For information on the maximum supported combinations and instructions for integrating Cisco Unity with multiple phone systems, refer to the applicable *Multiple Phone System Integration Guide* at http://www.cisco.com/en/US/products/sw/voicesw/ps2237/products_installation_and_configuration_guides_list.html.

Planning How the Voice Messaging Ports Will Be Used by Cisco Unity

Before programming the phone system, you need to plan how the voice messaging ports will be used by Cisco Unity. The following considerations will affect the programming for the phone system (for example, setting up the hunt group or call forwarding for the voice messaging ports):

- The number of voice messaging ports installed.
- The number of voice messaging ports that will answer calls.
- The number of voice messaging ports that will only dial out, for example, to send message notification, to set message waiting indicators (MWIs), to make AMIS deliveries, and to make telephone record and playback (TRAP) connections.

The following table describes the voice messaging port settings in Cisco Unity that can be set in UTIM, and that are displayed as read-only text on the System > Ports page of the Cisco Unity Administrator.

Table 1 **Settings for the Voice Messaging Ports**

Field	Considerations
Extension	Enter the extension for the port as assigned on the phone system.
Enabled	Check this check box to enable the port. The port is enabled during normal operation. Uncheck this check box to disable the port. When the port is disabled, calls to the port get a ringing tone but are not answered. Typically, the port is disabled only by the installer during testing.
Answer Calls	Check this check box to designate the port for answering calls. These calls can be incoming calls from unidentified callers or from subscribers.
Message Notification	Check this check box to designate the port for notifying subscribers of messages. Assign Message Notification to the least busy ports.

Table 1 **Settings for the Voice Messaging Ports (continued)**

Field	Considerations
Dialout MWI <i>(not used by serial or SMDI integrations)</i>	Check this check box to designate the port for turning MWIs on and off. Assign Dialout MWI to the least busy ports.
AMIS Delivery <i>(available with the AMIS licensed feature only)</i>	<p>Check this check box to designate the port for making outbound AMIS calls to deliver voice messages from Cisco Unity subscribers to users on another voice messaging system. Cisco Unity supports the Audio Messaging Interchange Specification (AMIS) protocol, which provides an analog mechanism for transferring voice messages between different voice messaging systems.</p> <p>This setting affects outbound AMIS calls only. All ports are used for incoming AMIS calls. Because the transmission of outgoing AMIS messages may tie up voice ports for long periods of time, you may want to adjust the schedule on the Network > AMIS > Schedule page so that outgoing AMIS calls are placed during closed hours or at times when Cisco Unity is not processing many calls.</p>
TRAP Connection	Check this check box so that subscribers can use the phone as a recording and playback device in Cisco Unity web applications and e-mail clients. Assign TRAP Connection to the least busy ports.

The Number of Voice Messaging Ports to Install

The number of voice messaging ports to install depends on numerous factors, including:

- The number of calls Cisco Unity will answer when call traffic is at its peak.
- The expected length of each message that callers will record and that subscribers will listen to.
- The number of subscribers.
- The number of ports that will be set to dial out only.
- The number of calls made for message notification.
- The number of MWIs that will be activated when call traffic is at its peak.
- The number of AMIS delivery calls.
- The number of TRAP connections needed when call traffic is at its peak. (TRAP connections are used by Cisco Unity web applications to play back and record over the phone.)
- The number of calls that will use the automated attendant and call handlers when call traffic is at its peak.

It is best to install only the number of voice messaging ports that are needed so that system resources are not allocated to unused ports.

The Number of Voice Messaging Ports That Will Answer Calls

The calls that the voice messaging ports answer can be incoming calls from unidentified callers or from subscribers. Typically, the voice messaging ports that answer calls are the busiest.

You can set voice messaging ports to both answer calls and to dial out (for example, to send message notifications). However, when the voice messaging ports perform more than one function and are very active (for example, answering many calls), the other functions may be delayed until the voice messaging port is free (for example, message notifications cannot be sent until there are fewer calls to answer). For best performance, dedicate certain voice messaging ports for only answering incoming calls, and

dedicate other ports for only dialing out. Separating these port functions eliminates the possibility of a collision, in which an incoming call arrives on a port at the same time that Cisco Unity takes the port off-hook to dial out.

The Number of Voice Messaging Ports That Will Only Dial Out, and Not Answer Calls

Ports that will only dial out and will not answer calls can do one or more of the following:

- Notify subscribers by phone, pager, or e-mail of messages that have arrived.
- Turn MWIs on and off for subscriber extensions.
- Make outbound AMIS calls to deliver voice messages from Cisco Unity subscribers to users on another voice messaging system. (This action is available only with the AMIS licensed feature.)
- Make a TRAP connection so that subscribers can use the phone as a recording and playback device in Cisco Unity web applications.

Typically, these voice messaging ports are the least busy ports.



Caution

In programming the phone system, do not send calls to voice messaging ports in Cisco Unity that cannot answer calls (voice messaging ports that are not set to Answer Calls). For example, if a voice messaging port is set only to Dialout MWI, do not send calls to it.

Preparing for Programming the Phone System

Record your decisions about the voice messaging ports to guide you in programming the phone system.

Programming the Avaya Definity/PBXLink Phone System

If you use programming options other than those supplied in the following procedure, the performance of the integration may be affected.



Caution

In programming the phone system, do not send calls to voice messaging ports in Cisco Unity that cannot answer calls (voice messaging ports that are not set to Answer Calls). For example, if a voice messaging port is set only to Message Notification, do not send calls to it.

Make sure that the phone system sends calls only to Cisco Unity voice ports that are set to Answer Calls on the System > Ports page in the Cisco Unity Administrator. Calls sent to a voice port not set to **Answer Calls** cannot be answered by Cisco Unity and may cause other problems.

Do the following procedures as applicable.

To Program the Phone System

- Step 1** Use the Add Station <extension number> command (for example, Add Station 2001) to assign an extension number for each voice messaging port. Set the following options and press **Enter**.

The options available may vary depending on the software version of your phone system.

Table 2 **Voice Messaging Port Options**

Option	Setting
Extension	<the extension number of the voice messaging port>
Type	2500
Port	<the physical address of the port>
Lock Messages?	n
Test?	n
Name	VoiceMail 2001 (The extension number must appear within the first 16 characters.)
LWC Reception?	n
LWC Activation?	y
Redirect Notification?	n
Off Premise Station?	n
Coverage Msg Retrieval Permission?	n
Data Restriction?	y
Call Waiting Indication?	n
Distinctive Audible Alert?	n
Message Waiting Indicator?	n
Adjunct Supervision	y

Step 2 Use the Add Station <extension number> command (for example, Add Station 2999) to assign an extension number for each digital line to the PBXLink box. Set the digital line options ([Table 3](#)) and button assignments ([Table 4](#)).

Table 3 **Digital Line Options for All Lines**

Option	Setting
Extension	<the extension number of the digital line>
Type	<ul style="list-style-type: none"> • 8434D • 7434D
Port	<the physical address of the port>
Data Module?	n
Expansion Module?	n
LWC Reception	None
LWC Activation?	y
CDR Privacy?	n
Redirect Notification?	n
Per Button Ring Control?	n
Bridged Call Alerting?	n

Table 3 *Digital Line Options for All Lines (continued)*

Option	Setting
Active Station Ringing	Single
Auto Select Any Idle Appearance?	n
Coverage Msg Retrieval?	y
Auto Answer	None
Data Restriction?	n
Idle Appearance Preference?	n
Restrict Last Appearance?	y
Audible Message Waiting?	n
Display Client Redirection?	n
Select Last Used Appearance?	n

Table 4 *Button Assignments for All Lines*

Button Assignment	Setting
1	call-appr
2	call-appr
3	call-appr
4	normal (Use the Normal setting for programming a 7434D phone. Leave the setting blank for an 8434D phone.)
5	inspect
6	
7	
8	
9	
10	call-appr

Step 3 Set the applicable feature button assignments depending on the number of PBXLink digital ports and whether load balancing is used.

If there is a single PBXLink digital port and load balancing is not used, set the feature button assignments as shown in [Table 5](#), then press **Enter**.

Table 5 *Feature Button Assignments for a Single PBXLink Digital Port Without Load Balancing*

Feature Button Number	Setting
1	abrdg-appr Extn: <1st voice mail extension>
2	abrdg-appr Extn: <2nd voice mail extension>

Table 5 *Feature Button Assignments for a Single PBXLink Digital Port Without Load Balancing (continued)*

Feature Button Number	Setting
3	abrdg-appr Extn: <3rd voice mail extension>
.	<the remaining voice mail extensions>
.	
.	

If there are two PBXLink digital ports and load balancing is used, set the feature button assignments as shown in both [Table 6](#) and [Table 7](#), then press **Enter**.

Table 6 *Feature Button Assignments for First of Two PBXLink Digital Ports with Load Balancing*

Feature Button Number	Setting
1	abrdg-appr Extn: <1st voice mail extension>
2	abrdg-appr Extn: <3rd voice mail extension>
3	abrdg-appr Extn: <5th voice mail extension>
.	<the remaining odd-numbered voice mail extensions>
.	
.	

Table 7 *Feature Button Assignments for Second of Two PBXLink Digital Ports with Load Balancing*

Feature Button Number	Setting
1	abrdg-appr Extn: <2nd voice mail extension>
2	abrdg-appr Extn: <4th voice mail extension>
3	abrdg-appr Extn: <6th voice mail extension>
.	<the remaining even-numbered voice mail extensions>
.	
.	

If there are three PBXLink digital ports and load balancing is used, set the feature button assignments as shown in [Table 8](#), [Table 9](#), and [Table 10](#), then press **Enter**.

Table 8 *Feature Button Assignments for First of Three PBXLink Digital Ports with Load Balancing*

Feature Button Number	Setting
1	abrdg-appr Extn: <1st voice mail extension>
2	abrdg-appr Extn: <4th voice mail extension>

Table 8 *Feature Button Assignments for First of Three PBXLink Digital Ports with Load Balancing (continued)*

Feature Button Number	Setting
3	abrdg-appr Extn: <7th voice mail extension>
.	<every third remaining voice mail extension>
.	
.	

Table 9 *Feature Button Assignments for Second of Three PBXLink Digital Ports with Load Balancing*

Feature Button Number	Setting
1	abrdg-appr Extn: <2nd voice mail extension>
2	abrdg-appr Extn: <5th voice mail extension>
3	abrdg-appr Extn: <8th voice mail extension>
.	<every third remaining voice mail extension>
.	
.	

Table 10 *Feature Button Assignments for Third of Three PBXLink Digital Ports with Load Balancing*

Feature Button Number	Setting
1	abrdg-appr Extn: <3rd voice mail extension>
2	abrdg-appr Extn: <6th voice mail extension>
3	abrdg-appr Extn: <9th voice mail extension>
.	<every third remaining voice mail extension>
.	
.	

If there are four PBXLink digital ports and load balancing is used, set the feature button assignments as shown in [Table 11](#), [Table 12](#), [Table 13](#), and [Table 14](#), then press **Enter**.

Table 11 *Feature Button Assignments for First of Four PBXLink Digital Ports with Load Balancing*

Feature Button Number	Setting
1	abrdg-appr Extn: <1st voice mail extension>
2	abrdg-appr Extn: <5th voice mail extension>
3	abrdg-appr Extn: <9th voice mail extension>
.	<every fourth remaining voice mail extension>
.	
.	

Table 12 *Feature Button Assignments for Second of Four PBXLink Digital Ports with Load Balancing*

Feature Button Number	Setting
1	abrdg-appr Extn: <2nd voice mail extension>
2	abrdg-appr Extn: <6th voice mail extension>
3	abrdg-appr Extn: <10th voice mail extension>
.	<every fourth remaining voice mail extension>
.	
.	

Table 13 *Feature Button Assignments for Third of Four PBXLink Digital Ports with Load Balancing*

Feature Button Number	Setting
1	abrdg-appr Extn: <3rd voice mail extension>
2	abrdg-appr Extn: <7th voice mail extension>
3	abrdg-appr Extn: <11th voice mail extension>
.	<every fourth remaining voice mail extension>
.	
.	

Table 14 *Feature Button Assignments for Fourth of Four PBXLink Digital Ports with Load Balancing*

Feature Button Number	Setting
1	abrdg-appr Extn: <4th voice mail extension>
2	abrdg-appr Extn: <8th voice mail extension>
3	abrdg-appr Extn: <12th voice mail extension>
.	<every fourth remaining voice mail extension>
.	
.	

If the phone system has 1 to 8 voice messaging ports or if it does not have vectoring capability, do the procedure [“To Set Up Coverage Paths for One to Eight Voice Messaging Ports or for Phone Systems Without Vectoring Capability.”](#) Otherwise, do the procedure [“To Set up Coverage Paths for More Than Eight Voice Messaging Ports.”](#)

To Set Up Coverage Paths for One to Eight Voice Messaging Ports or for Phone Systems Without Vectoring Capability

- Step 1** Refer to Chapter 6 in the PBXLink documentation, which is available from the manufacturer.

To Set up Coverage Paths for More Than Eight Voice Messaging Ports

- Step 1** For a phone system with more than eight voice messaging ports, use the **Add Vdn <extension number>** command (for example Add Vdn 2000) to set up a vector directory number for the pilot number (extension 2000 in this example). Set the following options and press **Enter**.

Table 15 Vector Direction Number Options

Option	Setting
Extension	<the pilot number>
Name	VoiceMail 2000
Display Override?	n
COR	1
Vector Number	1 (must match the Number option in Table 16)
Measured	none

- Step 2** Use the **Add Vector 1** or the **Change Vector 1** command to define the vector for voice messaging port extensions that answer calls. Set the options according to one of the following examples. Then press **Enter**.

For a system with a single PBXLink digital port, use the following example of a system with six lines.

Table 16 Vector Definition Options for a Single Digital Port

Option	Setting
Number	1 (must match the Vector Number option in Table 15)
Name	voicevec
ASAI Routing?	n
Basic?	y
Prompting?	n
01	wait time 0 secs hearing ringback
02	route to number 2001 if unconditionally (use the first voice messaging port extension)
03	route to number 2002 if unconditionally
04	route to number 2003 if unconditionally
05	route to number 2004 if unconditionally

Table 16 *Vector Definition Options for a Single Digital Port (continued)*

Option	Setting
06	route to number 2005 if unconditionally
07	route to number 2006 if unconditionally
08	busy

For a system with two PBXLink digital ports, use the following example, which bridges every second extension to Port A and the remaining extensions to Port B.

Table 17 *Vector Definition Options for Call Vector 1*

Option	Setting
Number	1
Name	voicevec1
ASAI Routing?	n
Basic?	y
Prompting?	n
01	wait time 0 secs hearing ringback
02	route to number 2001 if unconditionally
03	route to number 2002 if unconditionally
04	route to number 2003 if unconditionally
05	route to number 2004 if unconditionally
06	route to number 2005 if unconditionally
07	route to number 2006 if unconditionally
08	route to number 2007 if unconditionally
09	route to number 2008 if unconditionally
10	route to number 2009 if unconditionally
11	route to number 2010 if unconditionally
12	goto vector 2 if unconditionally

Table 18 *Vector Definition Options for Call Vector 2*

Option	Setting
Number	2
Name	voicevec2
ASAI Routing?	n
Basic?	y
Prompting?	n
01	route to number 2011 if unconditionally
02	route to number 2012 if unconditionally

Table 18 *Vector Definition Options for Call Vector 2 (continued)*

Option	Setting
03	route to number 2013 if unconditionally
04	route to number 2014 if unconditionally
05	route to number 2015 if unconditionally
06	route to number 2016 if unconditionally
07	route to number 2017 if unconditionally
08	route to number 2018 if unconditionally
09	route to number 2019 if unconditionally
10	route to number 2020 if unconditionally
11	busy

For a system with three PBXLink digital ports, use the following example, which bridges every third extension to Port A, another third of the extensions to Port B, and the remaining extensions to Port C.

Table 19 *Vector Definition Options for Call Vector 1*

Option	Setting
Number	1
Name	voicevec1
ASAI Routing?	n
Basic?	y
Prompting?	n
01	wait time 0 secs hearing ringback
02	route to number 2001 if unconditionally
03	route to number 2002 if unconditionally
04	route to number 2003 if unconditionally
05	route to number 2004 if unconditionally
06	route to number 2005 if unconditionally
07	route to number 2006 if unconditionally
08	route to number 2007 if unconditionally
09	route to number 2008 if unconditionally
10	route to number 2009 if unconditionally
11	route to number 2010 if unconditionally
12	goto vector 2 if unconditionally

Table 20 *Vector Definition Options for Call Vector 2*

Option	Setting
Number	2
Name	voicevec2
ASAI Routing?	n
Basic?	y
Prompting?	n
01	route to number 2011 if unconditionally
02	route to number 2012 if unconditionally
03	route to number 2013 if unconditionally
04	route to number 2014 if unconditionally
05	route to number 2015 if unconditionally
06	route to number 2016 if unconditionally
07	route to number 2017 if unconditionally
08	route to number 2018 if unconditionally
09	route to number 2019 if unconditionally
10	route to number 2020 if unconditionally
11	goto vector 3 if unconditionally

Table 21 *Vector Definition Options for Call Vector 3*

Option	Setting
Number	3
Name	voicevec3
ASAI Routing?	n
Basic?	y
Prompting?	n
01	route to number 2021 if unconditionally
02	route to number 2022 if unconditionally
03	route to number 2023 if unconditionally
04	route to number 2024 if unconditionally
05	route to number 2025 if unconditionally
06	route to number 2026 if unconditionally
07	route to number 2027 if unconditionally
08	route to number 2028 if unconditionally
09	route to number 2029 if unconditionally
10	route to number 2030 if unconditionally
11	busy

For a system with four PBXLink digital ports, use the following example, which bridges every fourth extension to Port A, another fourth of the extensions to Port B, another fourth of the extensions to Port C, and the remaining extensions to Port D.

Table 22 *Vector Definition Options for Call Vector 1*

Option	Setting
Number	1
Name	voicevec1
ASAI Routing?	n
Basic?	y
Prompting?	n
01	wait time 0 secs hearing ringback
02	route to number 2001 if unconditionally
03	route to number 2002 if unconditionally
04	route to number 2003 if unconditionally
05	route to number 2004 if unconditionally
06	route to number 2005 if unconditionally
07	route to number 2006 if unconditionally
08	route to number 2007 if unconditionally
09	route to number 2008 if unconditionally
10	route to number 2009 if unconditionally
11	route to number 2010 if unconditionally
12	goto vector 2 if unconditionally

Table 23 *Vector Definition Options for Call Vector 2*

Option	Setting
Number	2
Name	voicevec2
ASAI Routing?	n
Basic?	y
Prompting?	n
01	route to number 2011 if unconditionally
02	route to number 2012 if unconditionally
03	route to number 2013 if unconditionally
04	route to number 2014 if unconditionally
05	route to number 2015 if unconditionally
06	route to number 2016 if unconditionally
07	route to number 2017 if unconditionally
08	route to number 2018 if unconditionally

Table 23 *Vector Definition Options for Call Vector 2 (continued)*

Option	Setting
09	route to number 2019 if unconditionally
10	route to number 2020 if unconditionally
11	goto vector 3 if unconditionally

Table 24 *Vector Definition Options for Call Vector 3*

Option	Setting
Number	3
Name	voicevec3
ASAI Routing?	n
Basic?	y
Prompting?	n
01	route to number 20211 if unconditionally
02	route to number 2022 if unconditionally
03	route to number 2023 if unconditionally
04	route to number 2024 if unconditionally
05	route to number 2025 if unconditionally
06	route to number 2026 if unconditionally
07	route to number 2027 if unconditionally
08	route to number 2028 if unconditionally
09	route to number 2029 if unconditionally
10	route to number 2030 if unconditionally
11	goto vector 4 if unconditionally

Table 25 **Vector Definition Options for Call Vector 4**

Option	Setting
Number	4
Name	voicevec4
ASAI Routing?	n
Basic?	y
Prompting?	n
01	route to number 2031 if unconditionally
02	route to number 2032 if unconditionally
03	route to number 2033 if unconditionally
04	route to number 2034 if unconditionally
05	route to number 2035 if unconditionally
06	route to number 2036 if unconditionally
07	route to number 2037 if unconditionally
08	route to number 2038 if unconditionally
09	route to number 2039 if unconditionally
10	route to number 2040 if unconditionally
11	busy

After programming the phone system, it is necessary to set up the direct lines for users on the phone system.

To Set Up User Phones

-
- Step 1** Use the Change Station (extension number) command to display the Station screen for each extension.
 - Step 2** In the Name field, enter the user's name and extension. The PBXLink box can display only the first 16 characters, and the extension must appear in these 16 characters.
 - Step 3** In the Coverage Path field, enter **1**.
-

Setting Up the PBXLink Box

When setting up the PBXLink box, you can access the configuration menus through the display panel and buttons on the PBXLink box. For details, refer to the PBXLink documentation, which is available from the manufacturer.

To Update the PBXLink Box Firmware

Step 1 In a web browser on your computer, go to the **Cisco Unity Utilities Software Download** page at <http://www.cisco.com/cgi-bin/tablebuild.pl/unity-util>.



Note To access the software download page, you must be logged on to Cisco.com as a registered user.

Step 2 Click **PBXLinkFirmwareUpdate**.

Step 3 Follow the instructions to download the PBXLink box firmware update file to your computer.

Step 4 Exit the web browser.

Step 5 Confirm that the PBXLink box is connected to power and turned on.

Step 6 Disconnect the following cables:

- All phone cables connect to the PBXLink box.
- The RS-232 serial cable connected to the Management port

Step 7 Connect one end of an RS-232 serial cable to the Management port of the PBXLink box and the other end of the serial cable to the serial port of your computer.

Step 8 On your computer, start HyperTerminal or another terminal access application.

Step 9 Set the terminal access application to use the serial connection settings used by the PBXLink box. You can view the PBXLink serial connection settings by doing the following:

- a. On the PBXLink box, press **Cancel** until the Configuration menu appears.
- b. Click **OK**.
- c. Scroll up until Serial Port Options appears, and click **OK**.
- d. Scroll down until Management Port appears, and click **OK**.
- e. Scroll through the serial port settings to verify them.

Step 10 Restart the PBXLink box.

Step 11 In the HyperTerminal window on your computer, press **M** and press **Enter**.

Step 12 Press **3** (Reboot/Download), and press **Enter**.

Step 13 Press **2** (Reboot & Download Code), and press **Enter**.



Note Ignore any unusual characters that may appear on the screen.

Step 14 On the Transfer menu, click **Send File**.

Step 15 In the Send File dialog box, under Filename, click **Browse**.

Step 16 Browse to the PBXLink box firmware upgrade file that you downloaded to your computer.

Step 17 In the Send File dialog box, under Protocol, click **Xmodem**.

Step 18 Click **Send**.

Step 19 When the firmware upgrade is complete, exit HyperTerminal.

Step 20 Repeat [Step 5](#) through [Step 19](#) for all remaining PBXLink boxes.

- Step 21** Connect the PBXLink boxes to the phone system and to the Cisco Unity server.
-

To Set Up the PBXLink Box

- Step 1** On the PBXLink box, press **Cancel** until the main menu appears (the PBXLink version appears in the display).
- Step 2** On the main menu, press the Up or Down arrow to select **Configuration** and press **OK**.
- Step 3** On the Configuration menu, press the Up or Down arrow to select **Integration**.
- Step 4** Confirm that the Integration option is set to **Stopped**.
If the Integration option is set to **Started**, press **OK**, press the Right or Left arrow to select **Stopped**, and press **OK**.
- Step 5** On the Configuration menu, press the Up or Down arrow to select **PBX Type** and press **OK**.
- Step 6** On the PBX Type menu, press **OK**.
- Step 7** On the Select PBX Type menu, press the Right or Left arrow to select either **Lucent 2 wire** or **Lucent 4 wire** and press **OK**.
If the setting that you select is not the same as the setting that first appeared, the PBXLink box restarts.
- Step 8** If the PBXLink box does not restart, on the PBX Type menu, click **Cancel**.
If the PBXLink box restarts, on the main menu, press the Up or Down arrow to select **Configuration** and press **OK**.
- Step 9** On the Configuration menu, press the Up or Down arrow to select **PBX Options** and press **OK**.
- Step 10** On the PBX Options menu, press the Up or Down arrow to select **Phone Set** and press **OK**.
- Step 11** On the Phone Set menu, press the Right or Left arrow to select either **8434D** or **7434D** to match the digital port setting that you entered with the Add Station command. Then press **OK**.
- Step 12** On the PBX Options menu, press the Up or Down arrow to select **Voice Coding** and press **OK**.
- Step 13** On the Voice Coding menu, press the Right or Left arrow to select one of the following options and press **OK**:
- North America—**Mu Law**
 - All other locations—**A Law**
- Step 14** On the PBX Options menu, press the Up or Down arrow to select **Analog Ports on A** and press **OK**.
- Step 15** In the Analog Ports on A field, enter the number of voice messaging ports that Port A will monitor and press **OK**.
- Step 16** If you setting up a PBXLink-24 box, continue to [Step 17](#).
If you are setting up a PBXLink-48 box, do the following substeps:
- a. On the PBX Options menu, press the Up or Down arrow to select **Analog Ports on B**, and press **OK**.
 - b. In the Analog Ports on B field, enter the number of voice messaging ports that Port B will monitor and press **OK**.
- Step 17** On the PBX Options menu, press the Up or Down arrow to select **Configure Port A** and press **OK**.
- Step 18** On the Configure Port A menu, press the Left or Right arrow to select **Calls Only** and press **OK**.
- Step 19** If you are setting up a PBXLink-24 box, continue to [Step 20](#).

If you are setting up a PBXLink-48 box, do the following substeps:

- a. On the PBX Options menu, press the Up or Down arrow to select **Configure Port B** and press **OK**.
 - b. On the Configure Port B menu, press the Right or Left arrow to select **Calls Only** and press **OK**.
- Step 20** On the PBX Options menu, press the Up or Down arrow to select **Prime Number** and press **OK**.
- Step 21** In the Prime Number field, enter the pilot number that the phone system uses to call Cisco Unity, and press **OK**.
- Step 22** On the PBX Options menu, press the Up or Down arrow to select **Extension Length** and press **OK**.
- Step 23** In the Extension Length field, enter the number of digits in the subscriber extensions and press **OK**. If the subscriber extensions have different lengths, enter the number of digits in the longest extension.
- Step 24** On the PBX Options menu, press **Cancel**.
- Step 25** On the Configuration menu, press the Up or Down arrow to select **Integration** and press **OK**.
- Step 26** On the Integration menu, press the Right or Left arrow to select **Started** and press **OK**.

If the system has two or more PBXLink digital ports, we recommend that you balance the load among the PBXLink boxes by setting up the Port LTNs for random operation. Depending on the number of PBXLink digital ports and the number of PBXLink boxes that your system uses, do the applicable procedure that follows.

To Set Up the Port LTNs for Two PBXLink Digital Ports on One PBXLink Box

- Step 1** Confirm that the PBXLink Integration option is set to Stopped by doing the following substeps:
- a. On the main menu, press the Up or Down arrow to select **Configuration** and press **OK**.
 - b. On the Configuration menu, press the Up or Down arrow to select **Integration**.
 - c. Confirm that the Integration option is set to Stopped.

If the Integration option is set to Started, press **OK**, press the Right or Left arrow to select **Stopped**, and press **OK**.
- Step 2** On the Configuration menu, press the Up or Down arrow to select **SMDI Options** and press **OK**.
- Step 3** On the SMDI Options menu, press the Up or Down arrow to select **Port A LTNs**, and press **OK**.
- Step 4** On the Port A LTNs menu, press the Up or Down arrow to select **Mode of Operation** and press **OK**.
- Step 5** On the Mode of Operation menu, press the Right or Left arrow to select **Random** and press **OK**.
- Step 6** On the Port A LTNs menu, press the Up or Down arrow to select **Setup Random LTNs** and press **OK**.
- Step 7** In the Setup Random LTNs field, enter the voice messaging port values (not the extension) for each odd-numbered voice messaging port as shown in the following table, and press **OK**.

Table 26 *Random LTN Settings for Odd-Numbered Ports*

LTN Number	Voice Messaging Port Value
0	0001
1	0003

Table 26 *Random LTN Settings for Odd-Numbered Ports (continued)*

LTN Number	Voice Messaging Port Value
2	0005
.	<the remaining odd-numbered voice messaging ports>
.	
.	

- Step 8** After all the odd-numbered voice messaging ports are set, press **Cancel**.
- Step 9** On the Port A LTNs menu, press **Cancel**.
- Step 10** On the SMDI Options menu, press the Up or Down arrow to select **Port B LTNs** and press **OK**.
- Step 11** On the Port B LTNs menu, press the Up or Down arrow to select **Mode of Operation** and press **OK**.
- Step 12** On the Mode of Operation menu, press the Right or Left arrow to select **Random** and press **OK**.
- Step 13** On the Port B LTNs menu, press the Up or Down arrow to select **Setup Random LTNs** and press **OK**.
- Step 14** In the Setup Random LTNs field, enter the voice messaging port values (not the extension) for each even-numbered voice messaging port as shown in the following table, and press **OK**.

Table 27 *Random LTN Settings for Even-Numbered Ports*

LTN Number	Voice Messaging Port Value
0	0002
1	0004
2	0006
.	<the remaining even-numbered voice messaging ports>
.	
.	

- Step 15** After all the even-numbered voice messaging ports are set, press **Cancel**.
- Step 16** On the Port B LTNs menu, press **Cancel**.
- Step 17** On the SMDI Options menu, press **Cancel**.
- Step 18** On the Configuration menu, press the Up or Down arrow to select **Integration** and press **OK**.
- Step 19** On the Integration menu, press the Right or Left arrow to select **Started**, and press **OK**.
- Step 20** Continue to the [“Creating a New Integration with the Avaya Definity/PBXLink Phone System”](#) section on page 32.

To Set Up the Port LTNs for Two PBXLink Digital Ports on Two PBXLink Boxes

- Step 1** On the first PBXLink box, confirm that the PBXLink Integration option is set to Stopped by doing the following substeps:
- On the main menu, press the Up or Down arrow to select **Configuration** and press **OK**.
 - On the Configuration menu, press the Up or Down arrow to select **Integration**.
 - Confirm that the Integration option is set to Stopped.

If the Integration option is set to Started, press **OK**, press the Right or Left arrow to select **Stopped**, and press **OK**.

- Step 2** On the Configuration menu, press the Up or Down arrow to select **SMDI Options** and press **OK**.
- Step 3** On the SMDI Options menu, press the Up or Down arrow to select **Port A LTNs**, and press **OK**.
- Step 4** On the Port A LTNs menu, press the Up or Down arrow to select **Mode of Operation** and press **OK**.
- Step 5** On the Mode of Operation menu, press the Right or Left arrow to select **Random** and press **OK**.
- Step 6** On the Port A LTNs menu, press the Up or Down arrow to select **Setup Random LTNs** and press **OK**.
- Step 7** In the Setup Random LTNs field, enter the voice messaging port values (not the extension) for each odd-numbered voice messaging port as shown in the following table, and press **OK**.

Table 28 *Random LTN Settings for Odd-Numbered Ports*

LTN Number	Voice Messaging Port Value
0	0001
1	0003
2	0005
.	<the remaining odd-numbered voice messaging ports>
.	
.	

- Step 8** After all the odd-numbered voice messaging ports are set, press **Cancel**.
- Step 9** On the Port A LTNs menu, press **Cancel**.
- Step 10** On the SMDI Options menu, press **Cancel**.
- Step 11** On the Configuration menu, press the Up or Down arrow to select **Integration** and press **OK**.
- Step 12** On the Integration menu, press the Right or Left arrow to select **Started**, and press **OK**.
- Step 13** On the second PBXLink box, confirm that the PBXLink Integration option is set to Stopped by doing the following substeps:
 - a.** On the main menu, press the Up or Down arrow to select **Configuration** and press **OK**.
 - b.** On the Configuration menu, press the Up or Down arrow to select **Integration**.
 - c.** Confirm that the Integration option is set to Stopped.
 - If the Integration option is set to Started, press **OK**, press the Right or Left arrow to select **Stopped**, and press **OK**.
- Step 14** On the Configuration menu, press the Up or Down arrow to select **SMDI Options** and press **OK**.
- Step 15** On the SMDI Options menu, press the Up or Down arrow to select **Port A LTNs**, and press **OK**.
- Step 16** On the Port A LTNs menu, press the Up or Down arrow to select **Mode of Operation** and press **OK**.
- Step 17** On the Mode of Operation menu, press the Right or Left arrow to select **Random** and press **OK**.
- Step 18** On the Port A LTNs menu, press the Up or Down arrow to select **Setup Random LTNs** and press **OK**.
- Step 19** In the Setup Random LTNs field, enter the voice messaging port values (not the extension) for each even-numbered voice messaging port as shown in the following table, and press **OK**.

Table 29 **Random LTN Settings for Even-Numbered Ports**

LTN Number	Voice Messaging Port Value
0	0002
1	0004
2	0006
.	<the remaining even-numbered voice messaging ports>
.	
.	

- Step 20** After all the even-numbered voice messaging ports are set, press **Cancel**.
- Step 21** On the Port A LTNs menu, press **Cancel**.
- Step 22** On the SMDI Options menu, press **Cancel**.
- Step 23** On the Configuration menu, press the Up or Down arrow to select **Integration** and press **OK**.
- Step 24** On the Integration menu, press the Right or Left arrow to select **Started**, and press **OK**.
- Step 25** Continue to the [“Creating a New Integration with the Avaya Definity/PBXLink Phone System”](#) section on page 32.

To Set Up the Port LTNs for Three PBXLink Digital Ports (One PBXLink Box with One Digital Port and One PBXLink Box with Two Digital Ports)

This procedure sets up the port LTNs for every third voice messaging port when the first PBXLink box uses only Port A, and the second PBXLink box uses Port A and Port B.

- Step 1** On the first PBXLink box (which has one digital port), confirm that the PBXLink Integration option is set to Stopped by doing the following substeps:
- On the main menu, press the Up or Down arrow to select **Configuration** and press **OK**.
 - On the Configuration menu, press the Up or Down arrow to select **Integration**.
 - Confirm that the Integration option is set to Stopped.

If the Integration option is set to Started, press **OK**, press the Right or Left arrow to select **Stopped**, and press **OK**.
- Step 2** On the Configuration menu, press the Up or Down arrow to select **SMDI Options** and press **OK**.
- Step 3** On the SMDI Options menu, press the Up or Down arrow to select **Port A LTNs**, and press **OK**.
- Step 4** On the Port A LTNs menu, press the Up or Down arrow to select **Mode of Operation** and press **OK**.
- Step 5** On the Mode of Operation menu, press the Right or Left arrow to select **Random** and press **OK**.
- Step 6** On the Port A LTNs menu, press the Up or Down arrow to select **Setup Random LTNs** and press **OK**.
- Step 7** In the Setup Random LTNs field, enter the voice messaging port values (not the extension) for the first set of voice messaging port as shown in the following table, and press **OK**.

Table 30 *Random LTN Settings for the First Set of Ports*

LTN Number	Voice Messaging Port Value
0	0001
1	0004
2	0007
.	<the remaining voice messaging ports in the first set>
.	
.	

- Step 8** After all of the voice messaging ports in the first set are set, press **Cancel**.
- Step 9** On the Port A LTNs menu, press **Cancel**.
- Step 10** On the SMDI Options menu, press **Cancel**.
- Step 11** On the Configuration menu, press the Up or Down arrow to select **Integration** and press **OK**.
- Step 12** On the Integration menu, press the Right or Left arrow to select **Started**, and press **OK**.
- Step 13** On the second PBXLink box (which has two digital ports), confirm that the PBXLink Integration option is set to Stopped by doing the following substeps:
- On the main menu, press the Up or Down arrow to select **Configuration** and press **OK**.
 - On the Configuration menu, press the Up or Down arrow to select **Integration**.
 - Confirm that the Integration option is set to Stopped.
If the Integration option is set to Started, press **OK**, press the Right or Left arrow to select **Stopped**, and press **OK**.
- Step 14** On the Configuration menu, press the Up or Down arrow to select **SMDI Options** and press **OK**.
- Step 15** On the SMDI Options menu, press the Up or Down arrow to select **Port A LTNs**, and press **OK**.
- Step 16** On the Port A LTNs menu, press the Up or Down arrow to select **Mode of Operation** and press **OK**.
- Step 17** On the Mode of Operation menu, press the Right or Left arrow to select **Random** and press **OK**.
- Step 18** On the Port A LTNs menu, press the Up or Down arrow to select **Setup Random LTNs** and press **OK**.
- Step 19** In the Setup Random LTNs field, enter the voice messaging port values (not the extension) for the second set of voice messaging port as shown in the following table, and press **OK**.

Table 31 *Random LTN Settings for the Second Set of Ports*

LTN Number	Voice Messaging Port Value
0	0002
1	0005
2	0008
.	<the remaining voice messaging ports in the second set>
.	
.	

- Step 20** After all of the voice messaging ports in the second set are set, press **Cancel**.
- Step 21** On the Port A LTNs menu, press **Cancel**.

- Step 22** On the SMDI Options menu, press the Up or Down arrow to select **Port B LTNs** and press **OK**.
- Step 23** On the Port B LTNs menu, press the Up or Down arrow to select **Mode of Operation** and press **OK**.
- Step 24** On the Mode of Operation menu, press the Right or Left arrow to select **Random** and press **OK**.
- Step 25** On the Port B LTNs menu, press the Up or Down arrow to select **Setup Random LTNs** and press **OK**.
- Step 26** In the Setup Random LTNs field, enter the voice messaging port values (not the extension) for the third set of voice messaging port as shown in the following table, and press **OK**.

Table 32 *Random LTN Settings for the Third Set of Ports*

LTN Number	Voice Messaging Port Value
0	0003
1	0006
2	0009
.	<the remaining voice messaging ports in the third set>
.	
.	

- Step 27** After all of the voice messaging ports in the third set are set, press **Cancel**.
- Step 28** On the Port B LTNs menu, press **Cancel**.
- Step 29** On the SMDI Options menu, press **Cancel**.
- Step 30** On the Configuration menu, press the Up or Down arrow to select **Integration** and press **OK**.
- Step 31** On the Integration menu, press the Right or Left arrow to select **Started**, and press **OK**.
- Step 32** Continue to the [“Creating a New Integration with the Avaya Definity/PBXLink Phone System”](#) section on page 32.

To Set Up the Port LTNs for Three PBXLink Digital Ports (One PBXLink Box with Two Digital Ports and One PBXLink Box with One Digital Port)

This procedure sets up the port LTNs for every third voice messaging port when the first PBXLink box uses Port A and Port B, and the second PBXLink box uses only Port A.

- Step 1** On the first PBXLink box (which has two digital ports), confirm that the PBXLink Integration option is set to Stopped by doing the following substeps:
- On the main menu, press the Up or Down arrow to select **Configuration** and press **OK**.
 - On the Configuration menu, press the Up or Down arrow to select **Integration**.
 - Confirm that the Integration option is set to Stopped.

If the Integration option is set to Started, press **OK**, press the Right or Left arrow to select **Stopped**, and press **OK**.
- Step 2** On the Configuration menu, press the Up or Down arrow to select **SMDI Options** and press **OK**.
- Step 3** On the SMDI Options menu, press the Up or Down arrow to select **Port A LTNs**, and press **OK**.
- Step 4** On the Port A LTNs menu, press the Up or Down arrow to select **Mode of Operation** and press **OK**.
- Step 5** On the Mode of Operation menu, press the Right or Left arrow to select **Random** and press **OK**.

- Step 6** On the Port A LTNs menu, press the Up or Down arrow to select **Setup Random LTNs** and press **OK**.
- Step 7** In the Setup Random LTNs field, enter the voice messaging port values (not the extension) for the first set of voice messaging port as shown in the following table, and press **OK**.

Table 33 *Random LTN Settings for the First Set of Ports*

LTN Number	Voice Messaging Port Value
0	0001
1	0004
2	0007
.	<the remaining voice messaging ports in the first set>
.	
.	

- Step 8** After all of the voice messaging ports in the first set are set, press **Cancel**.
- Step 9** On the Port A LTNs menu, press **Cancel**.
- Step 10** On the SMDI Options menu, press the Up or Down arrow to select **Port B LTNs** and press **OK**.
- Step 11** On the Port B LTNs menu, press the Up or Down arrow to select **Mode of Operation** and press **OK**.
- Step 12** On the Mode of Operation menu, press the Right or Left arrow to select **Random** and press **OK**.
- Step 13** On the Port B LTNs menu, press the Up or Down arrow to select **Setup Random LTNs** and press **OK**.
- Step 14** In the Setup Random LTNs field, enter the voice messaging port values (not the extension) for the second set of voice messaging port as shown in the following table, and press **OK**.

Table 34 *Random LTN Settings for the Second Set of Ports*

LTN Number	Voice Messaging Port Value
0	0002
1	0005
2	0008
.	<the remaining voice messaging ports in the second set>
.	
.	

- Step 15** After all of the voice messaging ports in the second set are set, press **Cancel**.
- Step 16** On the Port B LTNs menu, press **Cancel**.
- Step 17** On the SMDI Options menu, press **Cancel**.
- Step 18** On the Configuration menu, press the Up or Down arrow to select **Integration** and press **OK**.
- Step 19** On the Integration menu, press the Right or Left arrow to select **Started**, and press **OK**.
- Step 20** On the second PBXLink box (which has one digital port), confirm that the PBXLink Integration option is set to Stopped by doing the following substeps:
- On the main menu, press the Up or Down arrow to select **Configuration** and press **OK**.
 - On the Configuration menu, press the Up or Down arrow to select **Integration**.
 - Confirm that the Integration option is set to Stopped.

If the Integration option is set to Started, press **OK**, press the Right or Left arrow to select **Stopped**, and press **OK**.

- Step 21** On the Configuration menu, press the Up or Down arrow to select **SMDI Options** and press **OK**.
- Step 22** On the SMDI Options menu, press the Up or Down arrow to select **Port A LTNs**, and press **OK**.
- Step 23** On the Port A LTNs menu, press the Up or Down arrow to select **Mode of Operation** and press **OK**.
- Step 24** On the Mode of Operation menu, press the Right or Left arrow to select **Random** and press **OK**.
- Step 25** On the Port A LTNs menu, press the Up or Down arrow to select **Setup Random LTNs** and press **OK**.
- Step 26** In the Setup Random LTNs field, enter the voice messaging port values (not the extension) for the third set of voice messaging port as shown in the following table, and press **OK**.

Table 35 *Random LTN Settings for the Third Set of Ports*

LTN Number	Voice Messaging Port Value
0	0003
1	0006
2	0009
.	<the remaining voice messaging ports in the third set>
.	
.	

- Step 27** After all of the voice messaging ports in the third set are set, press **Cancel**.
- Step 28** On the Port A LTNs menu, press **Cancel**.
- Step 29** On the SMDI Options menu, press **Cancel**.
- Step 30** On the Configuration menu, press the Up or Down arrow to select **Integration** and press **OK**.
- Step 31** On the Integration menu, press the Right or Left arrow to select **Started**, and press **OK**.
- Step 32** Continue to the [“Creating a New Integration with the Avaya Definity/PBXLink Phone System”](#) section on page 32.

To Set Up the Port LTNs for Three PBXLink Digital Ports (Three PBXLink Boxes with One Digital Port Each)

This procedure sets up the port LTNs for every third voice messaging port when each of the PBXLink boxes uses only Port A.

- Step 1** On the first PBXLink box (which has one digital port), confirm that the PBXLink Integration option is set to Stopped by doing the following substeps:
 - a.** On the main menu, press the Up or Down arrow to select **Configuration** and press **OK**.
 - b.** On the Configuration menu, press the Up or Down arrow to select **Integration**.
 - c.** Confirm that the Integration option is set to Stopped.
 - If the Integration option is set to Started, press **OK**, press the Right or Left arrow to select **Stopped**, and press **OK**.
- Step 2** On the Configuration menu, press the Up or Down arrow to select **SMDI Options** and press **OK**.
- Step 3** On the SMDI Options menu, press the Up or Down arrow to select **Port A LTNs**, and press **OK**.

- Step 4** On the Port A LTNs menu, press the Up or Down arrow to select **Mode of Operation** and press **OK**.
- Step 5** On the Mode of Operation menu, press the Right or Left arrow to select **Random** and press **OK**.
- Step 6** On the Port A LTNs menu, press the Up or Down arrow to select **Setup Random LTNs** and press **OK**.
- Step 7** In the Setup Random LTNs field, enter the voice messaging port values (not the extension) for the first set of voice messaging port as shown in the following table, and press **OK**.

Table 36 *Random LTN Settings for the First Set of Ports*

LTN Number	Voice Messaging Port Value
0	0001
1	0004
2	0007
.	<the remaining voice messaging ports in the first set>
.	
.	

- Step 8** After all of the voice messaging ports in the first set are set, press **Cancel**.
- Step 9** On the Port A LTNs menu, press **Cancel**.
- Step 10** On the SMDI Options menu, press **Cancel**.
- Step 11** On the Configuration menu, press the Up or Down arrow to select **Integration** and press **OK**.
- Step 12** On the Integration menu, press the Right or Left arrow to select **Started**, and press **OK**.
- Step 13** On the second PBXLink box (which has one digital port), confirm that the PBXLink Integration option is set to Stopped by doing the following substeps:
- On the main menu, press the Up or Down arrow to select **Configuration** and press **OK**.
 - On the Configuration menu, press the Up or Down arrow to select **Integration**.
 - Confirm that the Integration option is set to Stopped.
If the Integration option is set to Started, press **OK**, press the Right or Left arrow to select **Stopped**, and press **OK**.
- Step 14** On the Configuration menu, press the Up or Down arrow to select **SMDI Options** and press **OK**.
- Step 15** On the SMDI Options menu, press the Up or Down arrow to select **Port A LTNs**, and press **OK**.
- Step 16** On the Port A LTNs menu, press the Up or Down arrow to select **Mode of Operation** and press **OK**.
- Step 17** On the Mode of Operation menu, press the Right or Left arrow to select **Random** and press **OK**.
- Step 18** On the Port A LTNs menu, press the Up or Down arrow to select **Setup Random LTNs** and press **OK**.
- Step 19** In the Setup Random LTNs field, enter the voice messaging port values (not the extension) for the second set of voice messaging port as shown in the following table, and press **OK**.

Table 37 *Random LTN Settings for the Second Set of Ports*

LTN Number	Voice Messaging Port Value
0	0002
1	0005

Table 37 *Random LTN Settings for the Second Set of Ports (continued)*

LTN Number	Voice Messaging Port Value
2	0008
.	<the remaining voice messaging ports in the second set>
.	
.	

- Step 20** After all of the voice messaging ports in the second set are set, press **Cancel**.
- Step 21** On the Port A LTNs menu, press **Cancel**.
- Step 22** On the SMDI Options menu, press **Cancel**.
- Step 23** On the Configuration menu, press the Up or Down arrow to select **Integration** and press **OK**.
- Step 24** On the Integration menu, press the Right or Left arrow to select **Started**, and press **OK**.
- Step 25** On the third PBXLink box (which has one digital port), confirm that the PBXLink Integration option is set to Stopped by doing the following substeps:
- On the main menu, press the Up or Down arrow to select **Configuration** and press **OK**.
 - On the Configuration menu, press the Up or Down arrow to select **Integration**.
 - Confirm that the Integration option is set to Stopped.
If the Integration option is set to Started, press **OK**, press the Right or Left arrow to select **Stopped**, and press **OK**.
- Step 26** On the Configuration menu, press the Up or Down arrow to select **SMDI Options** and press **OK**.
- Step 27** On the SMDI Options menu, press the Up or Down arrow to select **Port A LTNs**, and press **OK**.
- Step 28** On the Port A LTNs menu, press the Up or Down arrow to select **Mode of Operation** and press **OK**.
- Step 29** On the Mode of Operation menu, press the Right or Left arrow to select **Random** and press **OK**.
- Step 30** On the Port A LTNs menu, press the Up or Down arrow to select **Setup Random LTNs** and press **OK**.
- Step 31** In the Setup Random LTNs field, enter the voice messaging port values (not the extension) for the third set of voice messaging port as shown in the following table, and press **OK**.

Table 38 *Random LTN Settings for the Third Set of Ports*

LTN Number	Voice Messaging Port Value
0	0003
1	0006
2	0009
.	<the remaining voice messaging ports in the third set>
.	
.	

- Step 32** After all of the voice messaging ports in the third set are set, press **Cancel**.
- Step 33** On the Port A LTNs menu, press **Cancel**.
- Step 34** On the SMDI Options menu, press **Cancel**.
- Step 35** On the Configuration menu, press the Up or Down arrow to select **Integration** and press **OK**.

- Step 36** On the Integration menu, press the Right or Left arrow to select **Started**, and press **OK**.
- Step 37** Continue to the [“Creating a New Integration with the Avaya Definity/PBXLink Phone System” section on page 32](#).

Creating a New Integration with the Avaya Definity/PBXLink Phone System

After ensuring that the Avaya Definity/PBXLink phone system and the Cisco Unity server are ready for the integration, do the following procedures to set up the integration and to enter the port settings.

To Create an Integration

- Step 1** If UTIM is not already open, on the Windows Start menu of the Cisco Unity server, click **Programs > Cisco Unity > Manage Integrations**. UTIM appears.
- Step 2** In the left pane of the UTIM window, click **Cisco Unity Server**.
- Step 3** On the Integration menu of the UTIM window, click **New**. The Telephony Integration Setup Wizard appears.
- Step 4** On the Welcome page, click **Circuit-Switched via Voice Card** and click **Next**.
- Step 5** On the Name the Phone System Integration page, accept the default name or enter the phone system name to identify this integration, then click **Next**.
- Step 6** On the Select Integration Method page, click **Serial**, then click **Next**.
- Step 7** On the Select Phone System Manufacturer page, click the following settings, then click **Next**.

Table 39 Settings for the Select Phone System Manufacturer Page

Field	Setting
Manufacturer	Avaya
Model	Definity Gx
Software Version	All (Analog MWI)
Configuration File	<if you have made copies of the .ini configuration file, the name of the configuration file that you want to use>

- Step 8** On the Enter MWI Codes page, enter the following settings, then click **Next**.

Table 40 Settings for the Enter MWI Codes Page

Field	Setting
MWI On Code	<the code you specified in the phone system for turning MWIs on>
MWI Off Code	<the code you specified in the phone system for turning MWIs off>

- Step 9** On the Select Serial Integration Packet Settings page, enter the following settings, then click **Next**.

Table 41 *Settings for the Select Serial Integration Packet Settings Page*

Field	Setting
Station Field Length	<the station prefix plus the default extension length; accept the default or click another setting; this length is either 10 or 7>
Default Extension Length	<the default length of extensions on the phone system; accept the default or click another setting>

Step 10 On the Select COM Port Settings page, enter the following settings, then click **Next**.

Table 42 *Settings for the Select COM Port Settings Page*

Field	Setting
COM Port	<the communications port on the Cisco Unity server that will receive the call information; typically, this setting is 1>
Baud Rate	<the baud rate that the phone system uses>
Data Bits	<the number of data bits that the phone system uses>
Stop Bits	<the number of stop bits that the phone system uses>
Parity	<the parity that the phone system uses>

Step 11 On the Set Number of Voice Messaging Ports page, enter the number of voice messaging ports on Cisco Unity that you want to connect to the phone system, then click **Next**.

This number cannot be more than the number of ports on the installed voice cards or the number of ports set up on the phone system.

Step 12 If other integrations already exist, the Enter Trunk Access Code page appears. Enter the extra digits that Cisco Unity must use to transfer calls through the gateway to extensions on the other phone systems with which it is integrated. Then click **Next**.

Step 13 On the Reassign Subscribers page, any subscribers whose phone system integration has been deleted and who are not currently assigned to a phone system integration will appear in the list.

If no subscribers appear in the list, click **Next** and continue to [Step 14](#).

Otherwise, select the subscribers that you want to assign to this phone system integration and click **Next**. You can use the following selection controls for selecting subscribers.

Table 43 *Selection Controls for the Reassign Subscribers Page*

Selection Control	Effect
Check All	Checks the check boxes for all subscribers in the list.
Uncheck All	Unchecks the check boxes for all subscribers in the list.
Toggle Selected	For the subscribers highlighted in the list, toggles between checking and unchecking the check boxes. If some highlighted subscriber check boxes are checked and others are unchecked, clicking this button will check all the check boxes. Clicking again will uncheck all the check boxes.

Step 14 On the Reassign Call Handlers page, any call handlers whose phone system integration has been deleted and that are not currently assigned to a phone system integration will appear in the list.

If no call handlers appear in the list, click **Next** and continue to [Step 15](#).

Otherwise, select the call handlers that you want to assign to this phone system integration and click **Next**. You can use the following selection controls for selecting call handlers.

Table 44 Selection Controls for the Reassign Call Handlers Page

Selection Control	Effect
Check All	Checks the check boxes for all call handlers in the list.
Uncheck All	Unchecks the check boxes for all call handlers in the list.
Toggle Selected	For the call handlers highlighted in the list, toggles between checking and unchecking the check boxes. If some highlighted call handler check boxes are checked and others are unchecked, clicking this button will check all the check boxes. Clicking again will uncheck all the check boxes.

Step 15 On the Completing page, verify the settings you entered, then click **Finish**.

Step 16 At the prompt to restart the Cisco Unity services, click **Yes**. The Cisco Unity services restart.

Alternatively, you can restart the Cisco Unity services in UTIM on the Tools menu by clicking **Restart Cisco Unity**.

To Enter the Voice Messaging Port Settings for the Integration

Step 1 After the Cisco Unity services restart, on the View menu, click **Refresh**.

Step 2 In the left pane of the UTIM window, expand the phone system integration that you are creating.

Step 3 In the left pane, click the name of the phone system.

Step 4 In the right pane, click the **Ports** tab.

Step 5 Enter the settings shown in [Table 1](#) for the voice messaging ports.

For best performance, use the first voice messaging ports for incoming calls and the last ports to dial out. This helps minimize the possibility of a collision, in which an incoming call arrives on a port at the same time that Cisco Unity takes the port off-hook to dial out.



Caution

In programming the phone system, do not send calls to voice messaging ports in Cisco Unity that cannot answer calls (voice messaging ports that are not set to Answer Calls). For example, if a voice messaging port is set only to Message Notification, do not send calls to it.

Table 45 **Settings for the Voice Messaging Ports**

Field	Considerations
Extension	Enter the extension for the port as assigned on the phone system.
Enabled	Check this check box to enable the port. The port is enabled during normal operation. Uncheck this check box to disable the port. When the port is disabled, calls to the port get a ringing tone but are not answered. Typically, the port is disabled only by the installer during testing.
Answer Calls	Check this check box to designate the port for answering calls. These calls can be incoming calls from unidentified callers or from subscribers.
Message Notification	Check this check box to designate the port for notifying subscribers of messages. Assign Message Notification to the least busy ports.
Dialout MWI <i>(not used by serial or SMDI integrations)</i>	Check this check box to designate the port for turning MWIs on and off. Assign Dialout MWI to the least busy ports.
AMIS Delivery <i>(available with the AMIS licensed feature only)</i>	Check this check box to designate the port for making outbound AMIS calls to deliver voice messages from Cisco Unity subscribers to users on another voice messaging system. Cisco Unity supports the Audio Messaging Interchange Specification (AMIS) protocol, which provides an analog mechanism for transferring voice messages between different voice messaging systems. This setting affects outbound AMIS calls only. All ports are used for incoming AMIS calls. Because the transmission of outgoing AMIS messages may tie up voice ports for long periods of time, you may want to adjust the schedule on the Network > AMIS > Schedule page so that outgoing AMIS calls are placed during closed hours or at times when Cisco Unity is not processing many calls.
TRAP Connection	Check this check box so that subscribers can use the phone as a recording and playback device in Cisco Unity web applications and e-mail clients. Assign TRAP Connection to the least busy ports.

Step 6 Click **Save**.

Step 7 Exit UTIM.

If your phone system uses MWI extension numbers that begin with zero (for example, 0123 or 09876), do the following procedure.

To Enable MWI Extensions That Begin with Zero

Step 1 On the Cisco Unity server, navigate to the \CommServer\Intlib directory on the drive on which you installed Cisco Unity.

Step 2 In the Intlib directory, locate the file Avsmdi.avd.

Step 3 Open the file in a text editor.

Step 4 In the [Fields] section of the file, locate the following line:

```
$LAMPEXT= 10 ZR, LAMPEXT
```

- Step 5** Change the ZR switch to V so the line reads:
- ```
$LAMPEXT= 10 V, LAMPEXT
```
- Step 6** Save the file and close the text editor.
- Step 7** For the settings to take effect, restart the Cisco Unity server.
- 

## Testing the Integration

To test whether Cisco Unity and the phone system are integrated correctly, do the following procedures in the order listed.

If any of the steps indicate a failure, refer to the following documentation as applicable:

- The installation guide for the phone system.
- *Cisco Unity Troubleshooting Guide*, available at [http://www.cisco.com/en/US/products/sw/voicesw/ps2237/prod\\_troubleshooting\\_guides\\_list.html](http://www.cisco.com/en/US/products/sw/voicesw/ps2237/prod_troubleshooting_guides_list.html).
- The setup information earlier in this guide.

### To Set Up the Test Configuration

---

- Step 1** Set up two test extensions (Phone 1 and Phone 2) on the same phone system that Cisco Unity is connected to.
- Step 2** Set Phone 1 to forward calls to the Cisco Unity pilot number when calls are not answered.



**Caution** The phone system must forward calls to the Cisco Unity pilot number in no fewer than four rings. Otherwise, the test may fail.

---

- Step 3** In the Cisco Unity Administrator, create a test subscriber to use for testing by doing the applicable substeps below.

If your message store is Microsoft Exchange, do the following:

- In the Cisco Unity Administrator, go to the **Subscribers > Subscribers > Profile** page.
- Click the **Add** icon.
- In the New subscriber field, click **Exchange**.
- On the Add Subscriber page, enter the applicable information.
- Click **Add**.

If your message store is IBM Lotus Domino, do the following:

- In the Cisco Unity Administrator, go to the **Subscribers > Subscribers > Profile** page.
- Click the **Add** icon.
- In the New Subscriber field, click **Notes**.
- In the Address Book list, confirm that the address book listed is the one that contains the user data that you want to import.

If the address book that you want to use is not listed, go to the **System > Configuration > Subscriber Address Books** page and add a different address book.

- e. In the Find Domino Person By list, indicate whether to search by short name, first name, or last name.
- f. Enter the applicable short name or name. You also can enter \* to display a list of all users, or enter one or more characters followed by \* to narrow your search.
- g. Click **Find**.
- h. On the list of matches, click the name of the user to import.
- i. On the Add Subscriber page, enter the applicable information.
- j. Click **Add**.

**Step 4** In the Extension field, enter the extension of Phone 1.

**Step 5** In the Active Schedule field, click **All Hours - All Days**.

**Step 6** Click the **Save** icon.

**Step 7** In the navigation bar, click **Call Transfer** to go to the Subscribers > Subscribers > Call Transfer page for the test subscriber.

For more information on transfer settings, refer to the “Subscriber Template Call Transfer Settings” section in the Cisco Unity Administrator Help.

**Step 8** In the Transfer Rule Applies To field, click **Standard**.

**Step 9** Under Transfer Incoming Calls, click **Yes, Ring Subscriber’s Extension**, and confirm that the extension number is for Phone 1.

**Step 10** Under Transfer Type, click **Release to Switch**.

**Step 11** Click the **Save** icon.

**Step 12** In the navigation bar, click **Messages** to go to the Subscribers > Subscribers > Messages page for the test subscriber.

**Step 13** Under Message Waiting Indicators (MWIs), check **Use MWI for Message Notification**.

**Step 14** In the Extension field, enter **x**.

**Step 15** Click the **Save** icon.

**Step 16** Open the Status Monitor by doing one of the following:

- In Internet Explorer, go to **http://<Cisco Unity server name>/web/sm**.
- Double-click the desktop shortcut to the Status Monitor.
- In the status bar next to the clock, right-click the Cisco Unity tray icon and click **Status Monitor**.

---

### To Test an External Call with Release Transfer

---

**Step 1** From Phone 2, enter the access code necessary to get an outside line, then enter the number outside callers use to dial directly to Cisco Unity.

**Step 2** On the Status Monitor, note which port handles this call.

**Step 3** When you hear the opening greeting, enter the extension for Phone 1. Hearing the opening greeting means that the port is configured correctly.

- Step 4** Confirm that Phone 1 rings and that you hear a ringback tone on Phone 2. Hearing a ringback tone means that Cisco Unity correctly released the call and transferred it to Phone 1.
  - Step 5** Leaving Phone 1 unanswered, confirm that the state of the port handling the call changes to “Idle.” This state means that release transfer is successful.
  - Step 6** Confirm that, after the number of rings that the phone system is set to wait, the call is forwarded to Cisco Unity and that you hear the greeting for the test subscriber. Hearing the greeting means that the phone system forwarded the unanswered call and the call-forward information to Cisco Unity, which correctly interpreted the information.
  - Step 7** On the Status Monitor, note which port handles this call.
  - Step 8** Leave a message for the test subscriber and hang up Phone 2.
  - Step 9** On the Status Monitor, confirm that the state of the port handling the call changes to “Idle.” This state means that the port was successfully released when the call ended.
  - Step 10** Confirm that the MWI on Phone 1 is activated. The activated MWI means that the phone system and Cisco Unity are successfully integrated for turning on MWIs.
- 

#### To Test Listening to Messages

---

- Step 1** From Phone 1, enter the internal pilot number for Cisco Unity.
  - Step 2** When asked for your password, enter the default password. Hearing the request for your password means that the phone system sent the necessary call information to Cisco Unity, which correctly interpreted the information.
  - Step 3** Confirm that you hear the recorded voice name for the test subscriber (if you did not record a voice name for the test subscriber, you will hear the extension number for Phone 1). Hearing the voice name means that Cisco Unity correctly identified the subscriber by the extension.
  - Step 4** When asked whether you want to listen to your message, press **1**.
  - Step 5** After listening to the message, press **3** to delete the message.
  - Step 6** Confirm that the MWI on Phone 1 is deactivated. The deactivated MWI means that the phone system and Cisco Unity are successfully integrated for turning off MWIs.
  - Step 7** Hang up Phone 1.
  - Step 8** On the Status Monitor, confirm that the state of the port handling the call changes to “Idle.” This state means that the port was successfully released when the call ended.
- 

#### To Set Up Supervised Transfer on Cisco Unity

---

- Step 1** In the Cisco Unity Administrator, go to the **Subscribers > Subscribers > Call Transfer** page.  
If the name of the test subscriber is not displayed, click the **Find** icon (the magnifying glass) in the title bar, then click **Find**, and select the name of the test subscriber in the list that appears.  
For more information on transfer settings, refer to the “Subscriber Template Call Transfer Settings” section in the Cisco Unity Administrator Help.
- Step 2** Under Transfer Type, click **Supervise Transfer**.
- Step 3** Set the Rings to Wait For field to **3**.

**Step 4** Click the **Save** icon.

---

#### To Test Supervised Transfer

---

- Step 1** From Phone 2, enter the access code necessary to get an outside line, then enter the number outside callers use to dial directly to Cisco Unity.
- Step 2** On the Status Monitor, note which port handles this call.
- Step 3** When you hear the opening greeting, enter the extension for Phone 1. Hearing the opening greeting means that the port is configured correctly.
- Step 4** Confirm that Phone 1 rings and that you do not hear a ringback tone on Phone 2. Instead, you should hear the indication your phone system uses to mean that the call is on hold (for example, music or beeps).
- Step 5** Leaving Phone 1 unanswered, confirm that the state of the port handling the call remains “Busy.” This state and hearing an indication that you are on hold mean that Cisco Unity is supervising the transfer.
- Step 6** Confirm that, after three rings, you hear the greeting for the test subscriber. Hearing the greeting means that Cisco Unity successfully recalled the supervised-transfer call.
- Step 7** During the greeting, hang up Phone 2.
- Step 8** On the Status Monitor, confirm that the state of the port handling the call changes to “Idle.” This state means that the port was successfully released when the call ended.
- 

#### To Delete the Test Subscriber

---

- Step 1** In the Cisco Unity Administrator, go to the **Subscribers > Subscribers > Profile** page.  
If the name of the test subscriber is not displayed, click the **Find** icon (the magnifying glass) in the title bar, then click **Find**, and select the name of the test subscriber in the list that appears.
- Step 2** In the title bar, click the **Delete Subscriber** icon (the X).
- Step 3** Click **Delete**.
- Step 4** When prompted to confirm deleting the subscriber, click **OK**.
- 

## Integrating a Secondary Server for Cisco Unity Failover

The Cisco Unity failover feature enables a secondary server to provide voice messaging services when the primary server becomes inactive. For information on installing a secondary server for failover, refer to the applicable Cisco Unity installation guide, available at

[http://www.cisco.com/en/US/products/sw/voicesw/ps2237/prod\\_installation\\_guides\\_list.html](http://www.cisco.com/en/US/products/sw/voicesw/ps2237/prod_installation_guides_list.html).

For information on failover, refer to the applicable *Cisco Unity Failover Configuration and Administration Guide* at

[http://www.cisco.com/en/US/products/sw/voicesw/ps2237/products\\_feature\\_guides\\_list.html](http://www.cisco.com/en/US/products/sw/voicesw/ps2237/products_feature_guides_list.html).

## Requirements

The following components are required to integrate a secondary server:

### Phone System

- A data splitter unit to split the single serial cable from the first PBXLink box (which connects to the Cisco Unity servers) into two serial cables.
- Two additional RS-232 serial cables (to be used with the serial cable that was connected from the PBXLink box directly to the primary server when it was integrated with the phone system). With these three serial cables, connect one serial cable from the SMDI port in the first PBXLink box to the data splitter unit; connect the second serial cable from the data splitter unit to the serial port on the primary server; and connect the third serial cable from the data splitter unit to the serial port on the secondary server.

### Cisco Unity Server

- One secondary server for each primary server installed and ready for the integration, as described in the applicable Cisco Unity installation guide and earlier in this integration guide.
- The applicable cable configuration for each analog voice messaging port to simultaneously connect the phone system to the corresponding ports on both the primary and the secondary servers. For example, connect port 1 on the phone system with both port 1 on the primary server and port 1 on the secondary server.
- A license that enables failover.

## Integration Description

The phone system uses PBXLink boxes to send call information to the primary and secondary servers. The analog voice messaging lines from the phone system provide voice connectivity to the primary and secondary servers. [Figure 3](#) shows the required connections.

**Figure 3** Connections Between the Phone System and Cisco Unity Servers

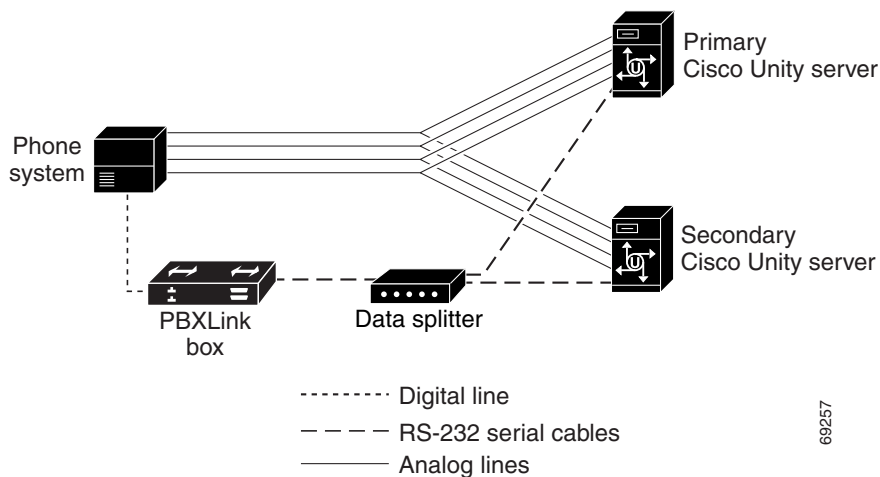

The primary and secondary servers act in the following manner:

- When the primary server is operating normally, the secondary server is inactive.

- When the primary server becomes inactive, the secondary server becomes active.
- When the primary server becomes active again, the secondary server becomes inactive.

## Setting Up the Secondary Server for Failover

Do the following procedure to integrate the secondary server.

### To Set Up the Secondary Server for Failover

- 
- Step 1** Install a secondary server with the same configuration as the primary server. For installation instructions, refer to the applicable Cisco Unity installation guide.
  - Step 2** Make all voice connections from the phone system to the corresponding ports on both the primary server and the secondary server. For example, connect port 1 from the phone system with port 1 on both the primary and the secondary servers.
  - Step 3** Connect one serial cable from the SMDI port in the first PBXLink box to the data splitter unit.
  - Step 4** Connect the remaining two serial cables to the two serial ports on the data splitter unit. Then connect one serial cable to the serial port on the primary server and the other serial cable to the serial port on the secondary server.
  - Step 5** On the Windows Start menu of the secondary server, click **Programs > Cisco Unity > Manage Integrations**. The UTIM window appears.
  - Step 6** On the Integration menu of the UTIM window, click **New**. The Telephony Integration Setup Wizard appears.
  - Step 7** Enter the settings to match the integration settings on the primary server.



---

**Note** We recommend not reassigning any unassigned subscribers and call handlers to the new integration, if you are asked by the wizard. Failover replication will automatically assign the correct integration.

---

- Step 8** At the prompt to restart the Cisco Unity services, click **Yes**.



---

**Note** When restarting the Cisco Unity services, use the UTIM prompt instead of the Cisco Unity icon in the Windows taskbar. The taskbar icon does not restart all of the Cisco Unity services.

---

- Step 9** After Cisco Unity restarts, on the Windows Start menu of the Cisco Unity server, click **Programs > Cisco Unity > Manage Integrations**. UTIM appears.
- Step 10** In the left pane of the UTIM window, click the phone system integration that you created in [Step 6](#).
- Step 11** In the right pane, click **Properties**.
- Step 12** On the Integration tab, compare the setting of the Integration ID field for the secondary server to the setting of the Integration ID field for the primary server.
- Step 13** If the integration IDs of the phone system on the primary and secondary server are the same, continue to [Step 19](#).

If the integration IDs of the phone system on the primary and secondary servers are different, on the secondary server, click **Modify Integration ID**.

- Step 14** When cautioned that subscribers associated with the current Integration ID setting will not be automatically associated with the new Integration ID setting, click **OK**.
- Step 15** In the Modify Integration ID dialog box, in the Enter New Integration ID field, enter the Integration ID setting for the phone system on the primary server and click **OK**.
- Step 16** Click **Save**.
- Step 17** At the prompt to restart the Cisco Unity services, click **No**.
- Step 18** In the left pane, click the phone system integration that you created in [Step 6](#).
- Step 19** In the right pane, click the **Ports** tab.
- Step 20** Enter the port settings to match the port settings on the primary server.



---

**Caution** In programming the phone system, do not send calls to voice messaging ports in Cisco Unity that cannot answer calls (voice messaging ports that are not set to Answer Calls). For example, if a voice messaging port is set only to Dialout MWI, do not send calls to it.

---

- Step 21** Click **Save**.
- Step 22** Exit UTIM.
- Step 23** Click **Programs > Cisco Unity > Edit Switch Utility**.
- Step 24** In the Switch Configuration Editor window, in the Manufacturer field, click **Avaya**.
- Step 25** In the Model field, click **Definity Gx**.
- Step 26** Click **Edit**.
- Step 27** In the Switch Configuration dialog box, click the **Incoming Calls** tab.
- Step 28** In the **Min. Ring on Time** field, enter **250**.
- Step 29** In the Call Rings field, enter **1** and click **OK**.
- Step 30** In the Switch Configuration Editor dialog box, click **Exit**.
- Step 31** On the Windows Start menu, click **Run**.
- Step 32** Enter **Regedit** and click **OK**.



---

**Caution** Changing the wrong registry key or entering an incorrect value can cause the server to malfunction. Before you edit the registry, confirm that you know how to restore it if a problem occurs. (Refer to the “Restoring” topics in Registry Editor Help.) If you have any questions about changing registry key settings, contact Cisco TAC.

---

- Step 33** If you do not have a current backup of the registry, click **Registry > Export Registry File**, and save the registry settings to a file.
- Step 34** Expand the key HKEY\_LOCAL\_MACHINE\Software\Active Voice\Miu\1.0\Initialization.
- Step 35** Double-click **New Call Delay on Inactive Backup Server**.
- Step 36** In the Edit DWORD Value dialog box, in the Value Data field, enter **15000** (decimal), and click **OK**.
- Step 37** Close the Registry Editor.
- Step 38** Restart the Cisco Unity server.
-

No changes to the hunt group programming on the phone system are necessary.

# Appendix: Documentation and Technical Assistance

## Conventions

The *Avaya Definity Gx/PBXLink Integration Guide for Cisco Unity 5.0* uses the following conventions.

**Table 46** *Avaya Definity Gx/PBXLink Integration Guide for Cisco Unity 5.0 Conventions*

| Convention                 | Description                                                                                                                                                                                                                                                                                                                                                                             |
|----------------------------|-----------------------------------------------------------------------------------------------------------------------------------------------------------------------------------------------------------------------------------------------------------------------------------------------------------------------------------------------------------------------------------------|
| boldfaced text             | Boldfaced text is used for: <ul style="list-style-type: none"> <li>Key and button names. (Example: Click <b>OK</b>.)</li> <li>Information that you enter. (Example: Enter <b>Administrator</b> in the User Name box.)</li> </ul>                                                                                                                                                        |
| < ><br>(angle brackets)    | Angle brackets are used around parameters for which you supply a value. (Example: In the Command Prompt window, enter <b>ping &lt;IP address&gt;</b> .)                                                                                                                                                                                                                                 |
| -<br>(hyphen)              | Hyphens separate keys that must be pressed simultaneously. (Example: Press <b>Ctrl-Alt-Delete</b> .)                                                                                                                                                                                                                                                                                    |
| ><br>(right angle bracket) | A right angle bracket is used to separate selections that you make: <ul style="list-style-type: none"> <li>On menus. (Example: On the Windows Start menu, click <b>Settings &gt; Control Panel &gt; Phone and Modem Options</b>.)</li> <li>In the navigation bar of the Cisco Unity Administrator. (Example: Go to the <b>System &gt; Configuration &gt; Settings</b> page.)</li> </ul> |
| [x]<br>(square brackets)   | Square brackets enclose an optional element (keyword or argument). (Example: [reg-e164])                                                                                                                                                                                                                                                                                                |
| [x   y]<br>(vertical line) | Square brackets enclosing keywords or arguments separated by a vertical line indicate an optional choice. (Example: [transport tcp   transport udp])                                                                                                                                                                                                                                    |
| {x   y}<br>(braces)        | Braces enclosing keywords or arguments separated by a vertical line indicate a required choice. (Example: {tcp   udp})                                                                                                                                                                                                                                                                  |

The *Avaya Definity Gx/PBXLink Integration Guide for Cisco Unity 5.0* also uses the following conventions:



**Note**

Means *reader take note*. Notes contain helpful suggestions or references to material not covered in the document.

**Caution**

Means *reader be careful*. In this situation, you might do something that could result in equipment damage or loss of data.

For descriptions and URLs of Cisco Unity documentation on Cisco.com, see the *About Cisco Unity Documentation*. The document is shipped with Cisco Unity and is available at [http://www.cisco.com/en/US/products/sw/voicesw/ps2237/products\\_documentation\\_roadmaps\\_list.html](http://www.cisco.com/en/US/products/sw/voicesw/ps2237/products_documentation_roadmaps_list.html).

## Obtaining Documentation, Obtaining Support, and Security Guidelines

For information on obtaining documentation, obtaining support, providing documentation feedback, security guidelines, and also recommended aliases and general Cisco documents, see the monthly *What's New in Cisco Product Documentation*, which also lists all new and revised Cisco technical documentation, at:

<http://www.cisco.com/en/US/docs/general/whatsnew/whatsnew.html>

CCVP, the Cisco logo, and Welcome to the Human Network are trademarks of Cisco Systems, Inc.; Changing the Way We Work, Live, Play, and Learn is a service mark of Cisco Systems, Inc.; and Access Registrar, Aironet, Catalyst, CCDA, CCDP, CCIE, CCIP, CCNA, CCNP, CCSP, Cisco, the Cisco Certified Internetwork Expert logo, Cisco IOS, Cisco Press, Cisco Systems, Cisco Systems Capital, the Cisco Systems logo, Cisco Unity, Enterprise/Solver, EtherChannel, EtherFast, EtherSwitch, Fast Step, Follow Me Browsing, FormShare, GigaDrive, HomeLink, Internet Quotient, IOS, iPhone, IP/TV, iQ Expertise, the iQ logo, iQ Net Readiness Scorecard, iQuick Study, LightStream, Linksys, MeetingPlace, MGX, Networkers, Networking Academy, Network Registrar, PIX, ProConnect, ScriptShare, SMARTnet, StackWise, The Fastest Way to Increase Your Internet Quotient, and TransPath are registered trademarks of Cisco Systems, Inc. and/or its affiliates in the United States and certain other countries.

All other trademarks mentioned in this document or Website are the property of their respective owners. The use of the word partner does not imply a partnership relationship between Cisco and any other company. (0711R)

Any Internet Protocol (IP) addresses used in this document are not intended to be actual addresses. Any examples, command display output, and figures included in the document are shown for illustrative purposes only. Any use of actual IP addresses in illustrative content is unintentional and coincidental.

© 2007 Cisco Systems, Inc. All rights reserved.