



## Voice Cards

This appendix contains the following sections:

- [Intel Dialogic D/41EPCI, D/41JCT-LS, and D/41JCT-Euro, page A-1](#)
- [Intel Dialogic D/120JCT-LS and D/120JCT-Euro, page A-4](#)
- [Intel Dialogic D/240PCI-T1, page A-8](#)
- [Removing Intel Dialogic Software, page A-11](#)

## Intel Dialogic D/41EPCI, D/41JCT-LS, and D/41JCT-Euro

The D/41EPCI, D/41JCT-LS, and D/41JCT-Euro voice cards provide four independent voice-processing ports in a single PCI slot. The cards connect four phone-line interface circuits directly to analog loop-start lines by using RJ-11 connectors.

If you are installing cards that have H.100 connectors, you need an H.100 cable that has at least as many connectors as you have cards (you must connect all cards by using a single cable) but no more than five extra connectors.

**Figure A-1** D/41EPCI Top and Side Views

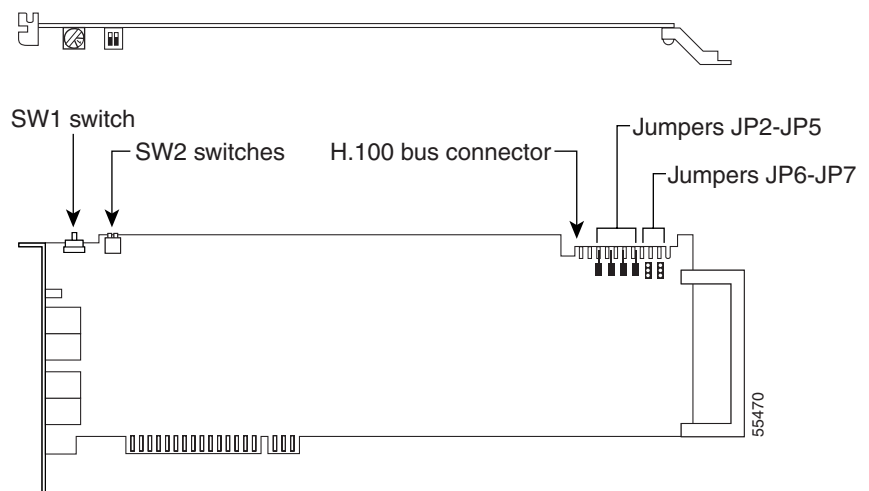

Figure A-2 D/41JCT-LS, and D/41JCT-Euro Top and Side Views

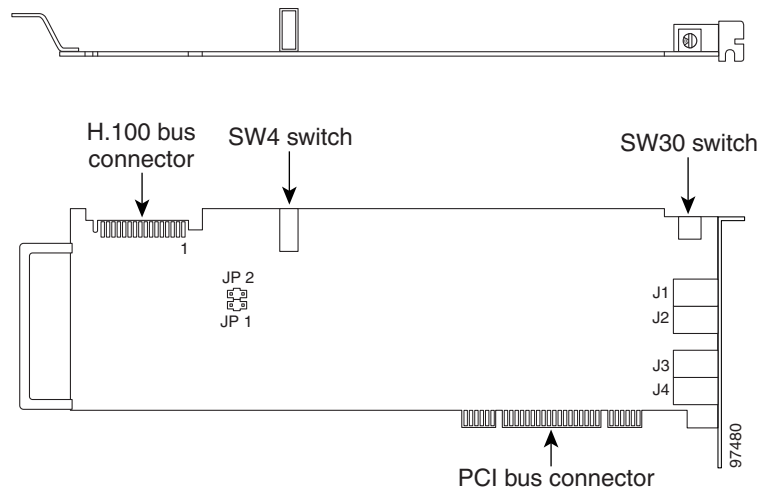
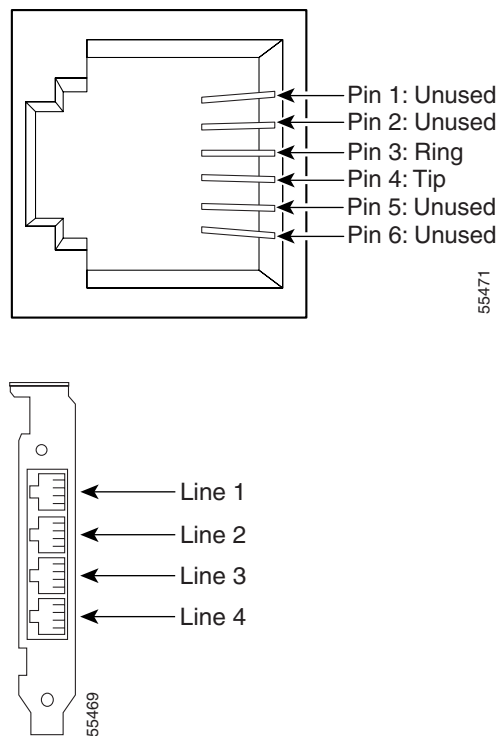

Figure A-3 D/41EPCI, D/41JCT-LS, and D/41JCT-Euro Connection Pinouts and Backplate



## Hardware Settings

### To Set the D/41EPCI Card Switches and Jumpers

- Step 1** Set the rotary switch (SW1) to a unique value for each card.

Each Intel Dialogic card in the Cisco Unity server or expansion chassis must have a unique value, starting with **1** and continuing in sequence on subsequent cards. For example, set the rotary switch on the first three voice cards as shown below. This is also the order in which you install the cards in the server or expansion chassis.

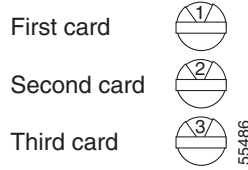

**Step 2** Set SW2 switches to **Off** on each card.

**Step 3** Settings for jumpers JP2 through JP5 depend on the number of D/41EPCI voice cards in the Cisco Unity server or expansion chassis:

<b>One card</b>	Set jumpers JP2 through JP5 to <b>Off</b> (Figure A-4) on the card.
<b>Two cards</b>	Set jumpers JP2 through JP5 to <b>On</b> (Figure A-5) on both cards.
<b>Three or more cards</b>	Set jumpers JP2 through JP5 to <b>On</b> (Figure A-5) on the first and last cards. Set jumpers JP2 through JP5 to <b>Off</b> (Figure A-4) on all other cards.

**Figure A-4 D/41EPCI Jumpers JP2 Through JP 5: Off**

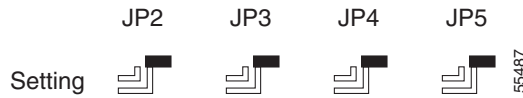

**Figure A-5 D/41EPCI Jumpers JP2 Through JP 5: On**

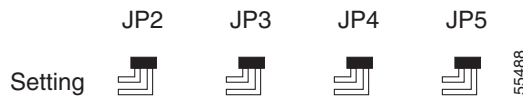

**Step 4** On jumpers JP6 and JP7, install shunts on the top two pins (1 and 2).

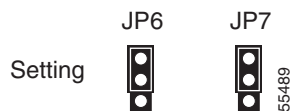

### To Set the D/41JCT-LS and D/41JCT-Euro Card Switches and Jumpers

**Step 1** Set the rotary switch (SW30) to a unique value for each card.

Each Intel Dialogic card in the Cisco Unity server or expansion chassis must have a unique value, starting with **1** and continuing in sequence on subsequent cards. For example, set the rotary switch on the first three voice cards as shown below. This is also the order in which you install the cards in the Cisco Unity server or expansion chassis.

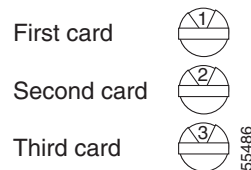

**Step 2** Set the SW4 hook-state switch to **Off**.

**Step 3** Settings for jumpers JP1 and JP2 are as follows:

Jumper JP1 is reserved. Do not install a shunt across the pins of JP1.

Set jumper JP2 according to the number of D/41JCT-LS or D/41JCT-EURO cards in the server or expansion chassis:

<b>One card</b>	Unterminated (the default configuration).
<b>Two or more cards</b>	Install the shunt on the JP2 jumper of a card to terminate the CT bus (H.100 signal) at that card. Terminate only the first and last cards on the CT bus cable.

## Intel Dialogic D/120JCT-LS and D/120JCT-Euro

The D/120JCT-LS and D/120JCT-Euro voice cards each provide 12 channels of call-processing and loop-start interfaces in a single PCI slot. The D/120JCT-LS is used in North America, South America, and Japan, and the D/120JCT-Euro is used in Europe, Australia, and New Zealand. The cards connect 12 analog loop-start phone lines to 12 onboard call-processing resources by using RJ-14 connectors.

We recommend using the newer Revision 2 Universal (3.3Vdc or 5Vdc dual voltage) PCI versions of the Intel Dialogic D/120JCT-LS and the D/120JCT-Euro cards, rather than the older single-bus voltage (5Vdc) versions of the cards.

Note that older Revision 1 LS cards are still supported for use with Cisco Unity version 4.0(x), but they cannot be ordered for new Cisco Unity version 4.0(x) installations. In addition, the older LS cards can be used only when they are appropriate for the available slots in the Cisco Unity server or expansion chassis.

If you are installing cards that have H.100 connectors, you need an H.100 cable that has at least as many connectors as you have cards (you must connect all cards by using a single cable) but no more than five extra connectors.

You may need to attach or remove the slot retainer bracket that ships with the card, depending on the mechanical configuration of the Cisco Unity server or expansion chassis.

Figure A-6 D/120JCT-LS and D/120JCT-Euro Rev 1 (Conventional PCI) Top and Side Views

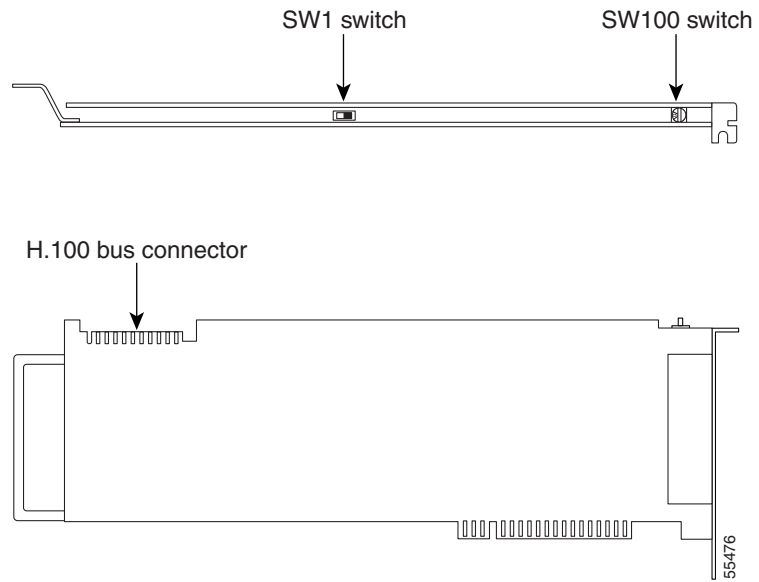

Figure A-7 D/120JCT-LS and D/120JCT-Euro Rev 2 (uPCI) Top and Side Views

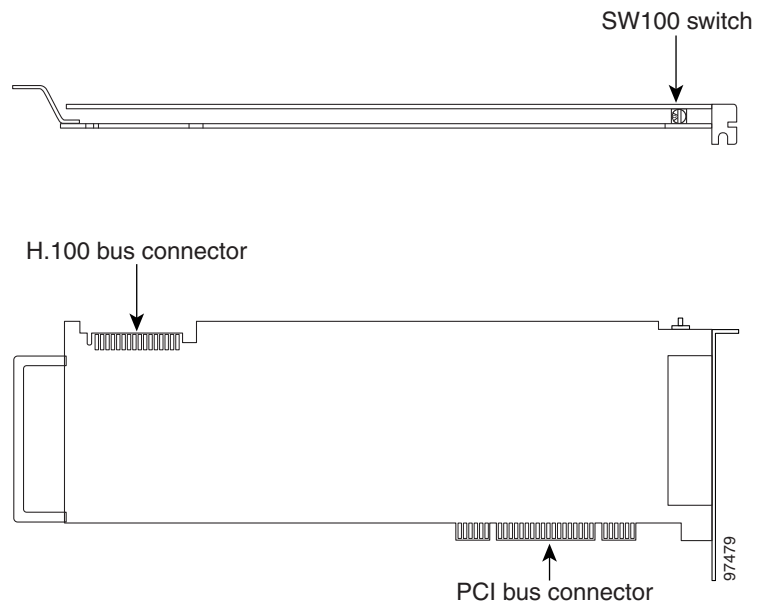
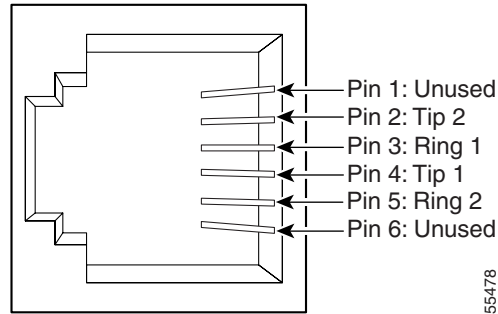
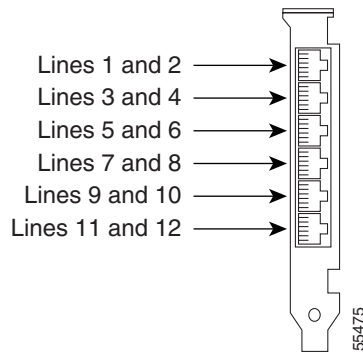

Figure A-8 D/120JCT-LS and D/120JCT-Euro Connection Pinouts and Backplate



55478



55475

## Hardware Settings

### To Set the D/120JCT-LS and D/120JCT-Euro Card Switches

**Step 1** Set the rotary switch (SW100) to a unique value for each card.

Each Intel Dialogic card in the Cisco Unity server or expansion chassis must have a unique value, starting with **1** and continuing in sequence on subsequent cards. For example, set the rotary switch on the first three voice cards as shown below. This is also the order in which you install the cards in the server.

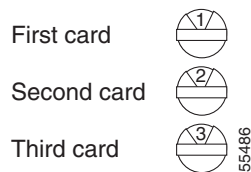

55486

- Step 2** Set the SW1 switch to **On Hook** on each card.

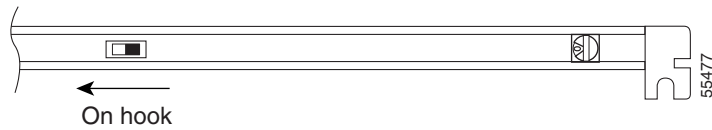

## Software Settings

Do the following procedure only if the Cisco Unity server contains D/120JCT-Euro voice cards. There are no software settings for D/120JCT-LS voice cards.

### To Select the Country for D/120JCT-Euro Voice Cards

- Step 1** Exit the Cisco Unity software, if it is running. For more information, see [Appendix B, “Exiting and Starting the Cisco Unity Software and Server.”](#)
- Step 2** Click **Programs > Administrative Tools > Services**.
- Step 3** In the right pane of the Services dialog box, right-click **Telephony**, and click **Stop**.
- Step 4** If you are prompted to stop other services, click **Yes**.
- Step 5** On the Windows Start menu, click **Programs > Dialogic System Software > Dialogic Configuration Manager–DCM**.
- Step 6** When the message “DCM could not detect devices...” appears, click **OK**.
- Step 7** In the DCM toolbar, click the red button to stop the Dialogic service.
- Step 8** When the Dialogic service has stopped, click **Close**.
- Step 9** In the Dialogic Configuration Manager dialog box, in the list of installed cards, double-click a D/120JCT-Euro card.
- Step 10** In the Dialogic Configuration Manager Properties dialog box, click the **Country** tab.
- Step 11** In the Country list, click the applicable value:

<b>Euro (CTR-21)</b>	For all countries that require CE conformity, including Austria, Belgium, Denmark, Finland, France, Germany, Greece, Hong Kong, Iceland, Ireland, Italy, Liechtenstein, Luxembourg, the Netherlands, Norway, Portugal, Spain, Sweden, Switzerland, and the United Kingdom.
<b>Australia</b>	For Australia.
<b>New Zealand</b>	For New Zealand.

- Step 12** If you chose Australia or New Zealand in the Country list, then in the Frequency Resolution list, click **FREQRES\_LOW**.
- Step 13** Click **OK**.
- Step 14** Repeat Steps 9 through 13 for each D/120JCT-Euro card installed in the system.

- Step 15** Close the DCM.
- Step 16** Restart the Cisco Unity server.
- 

## Intel Dialogic D/240PCI-T1

The Dialogic D/240PCI-T1 voice card provides one T1 span with 24 channels of voice processing in a single PCI slot. The card connects directly to a channel-service unit, digital-service unit, or to other phone-network terminating equipment by using an RJ-48C connector.

If you are installing cards that have H.100 connectors, you need an H.100 cable that has at least as many connectors as you have cards (you must connect all cards by using a single cable) but no more than five extra connectors.

**Figure A-9** D/240PCI-T1 Top and Side Views

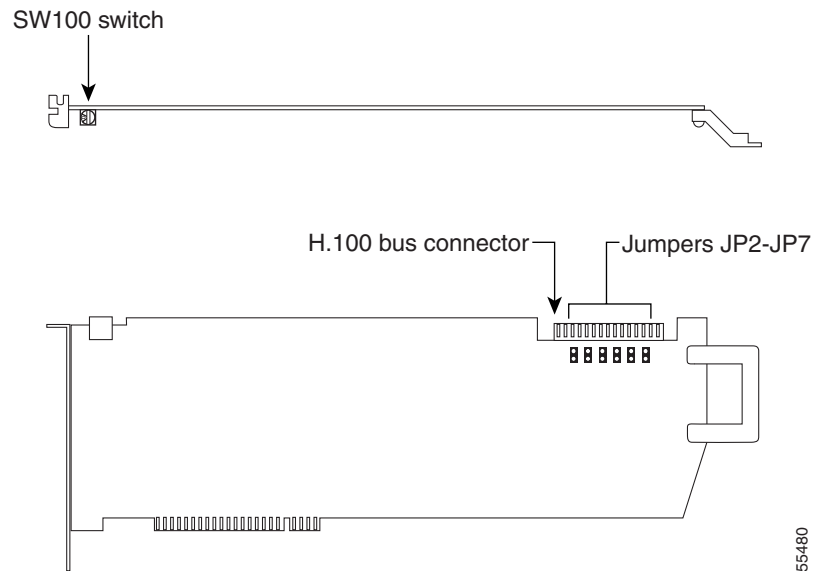
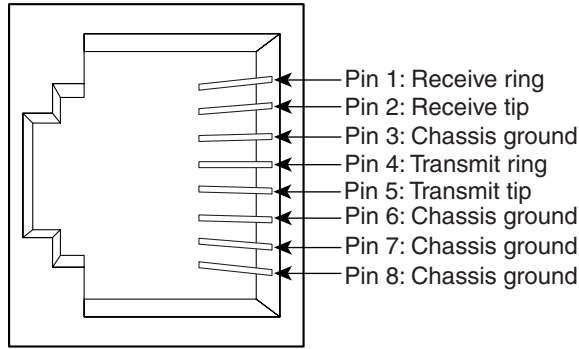
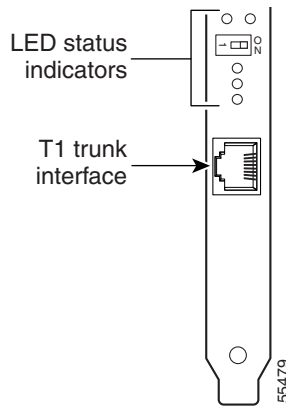

Figure A-10 D/240PCI-T1 Connection Pinouts and Backplate



55481



55479

## Hardware Settings

### To Set the D/240PCI-T1 Card Switches and Jumpers

**Step 1** Set the rotary switch (SW100) to a unique value.

Each Intel Dialogic card in the Cisco Unity server or expansion chassis must have a unique value, starting with **1** and continuing in sequence on subsequent cards. For example, set the rotary switch on the first three voice cards as shown below. This is also the order in which you install the cards in the server.

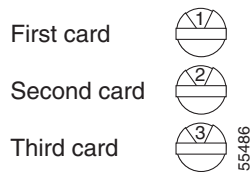

55486

- Step 2** Settings for jumpers JP2 through JP5 depend on the number of D/240PCI-T1 voice cards in the Cisco Unity server:

<b>One card</b>	Set jumpers JP2 through JP5 to <b>Off</b> (Figure A-11) on the card.
<b>Two cards</b>	Set jumpers JP2 through JP5 to <b>On</b> (Figure A-12) on both cards.
<b>Three or more cards</b>	Set jumpers JP2 through JP5 to <b>On</b> (Figure A-12) on the first and last cards. Set jumpers JP2 through JP5 to <b>Off</b> (Figure A-11) on all other cards.

**Figure A-11 D/240PCI-T1 Jumpers JP2 Through JP 5: Off**

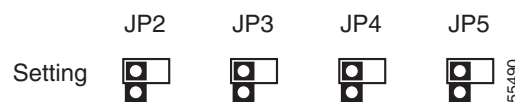

**Figure A-12 D/240PCI-T1 Jumpers JP2 Through JP 5: On**

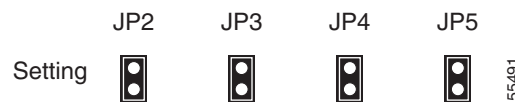

- Step 3** On jumpers JP6 and JP7, install shunts on the top two pins (1 and 2).

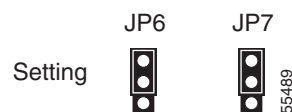

## Software Settings

For a D/240PCI-T1 voice card, set the protocol manually after the Cisco Unity Setup program is finished.

### To Set the D/240PCI-T1 Protocol

- Step 1** On the Windows Start menu, click **Settings > Control Panel > Phone and Modem Options**.
- Step 2** In the Phone and Modem Options dialog box, click the **Advanced** tab.
- Step 3** Click **Dialogic Generation 2 Service Provider for NT**.
- Step 4** Click **Configure**.
- Step 5** In the Dialogic TSP Configuration dialog box, click **Advanced**.
- Step 6** In the Configuration Service dialog box, click the **Digital Protocols** tab.
- Step 7** In the Currently Assigned Protocols list, click **DtiB1 Undefined Protocol**.

- Step 8** In the Available Protocols list, click **Us\_Is\_fxs\_io**.
  - Step 9** Click **Set Protocol**. DtiB1 Undefined Protocol changes to Us\_Is\_fxs\_io.
  - Step 10** If the Currently Assigned Protocols list contains more than one item (when the Cisco Unity server contains more than one D/240PCI-T1 card), repeat Steps 7 through 9 to change the remaining items from DtiB1 Undefined Protocol to Us\_Is\_fxs\_io.
  - Step 11** Click **OK** to close the Configuration Service dialog box.
  - Step 12** Click **OK** to close the Dialogic TSP Configuration dialog box.
  - Step 13** Click **Close** to close the Phone and Modem Options dialog box.
  - Step 14** Close Control Panel.
- 

## Removing Intel Dialogic Software

### Determining the Current Setting for the Intel Dialogic Quiet Parameter

When the Intel Dialogic quiet parameter has been set to a value other than the default, the setting will be lost when you remove the Intel Dialogic software. Write down the current value of the quiet parameter so you can restore that value after you reinstall the software.

#### To Determine the Current Setting for the Intel Dialogic Quiet Parameter

---

- Step 1** Exit the Cisco Unity software, if it is running. For more information, see [Appendix B, “Exiting and Starting the Cisco Unity Software and Server.”](#)
  - Step 2** Click **Programs > Administrative Tools > Services**.
  - Step 3** In the right pane of the Services dialog box, right-click **Telephony**, and click **Stop**.
  - Step 4** If you are prompted to stop other services, click **Yes**.
  - Step 5** On the Windows Start menu, click **Programs > Dialogic System Software > Dialogic Configuration Manager–DCM**.  
The tree-structured list contains an entry for each Intel Dialogic card installed in the server.
  - Step 6** On the Service menu, click **Stop Service**.
  - Step 7** Double-click a voice card in the tree list.
  - Step 8** In the Properties dialog box for the card, click the **Misc** tab.
  - Step 9** Under Parameter, note and write down the value of ParameterFile.
  - Step 10** Click **OK**.
- 

## Removing the Intel Dialogic Software

The following procedure may differ slightly for earlier versions of Cisco Unity, which used an earlier version of Dialogic Configuration Manager.

### To Remove Intel Dialogic Software

- 
- Step 1** Exit the Cisco Unity software, if it is running. For more information, see [Appendix B, “Exiting and Starting the Cisco Unity Software and Server.”](#)
- Step 2** Click **Programs > Administrative Tools > Services**.
- Step 3** In the right pane of the Services dialog box, right-click **Telephony**, and click **Stop**.
- Step 4** If you are prompted to stop other services, click **Yes**.
- Step 5** On the Windows Start menu, click **Programs > Dialogic Systems Software > Dialogic Configuration Manager–DCM**.
- Dialogic Configuration Manager may display an error message about not detecting devices. This error is harmless. Click **OK**.
- Step 6** On the Service menu, click **Stop Service**.
- Step 7** Click **Close**.
- Step 8** Close the DCM.
- Step 9** On the Windows Start menu, click **Settings > Control Panel > Phone and Modem Options**.
- Step 10** Click the **Advanced** tab.
- Step 11** Click Dialogic **Generation 2 Service Provider for NT**.
- If you are using D/160SC voice cards and VoiceBridge 2000 feature-set cards, this option will be **DSE Service Provider**.
- Step 12** Click **Remove**.
- Step 13** Click **Yes**.
- Step 14** Click **Close** to close the Phone and Modem Options dialog box.
- Step 15** In Control Panel, double-click **Sounds and Multimedia**.
- Step 16** In the Sounds and Multimedia Options dialog box, click the **Hardware** tab.
- Step 17** Click **Legacy Audio Drivers**.
- Step 18** Click **Properties**.
- Step 19** In the Legacy Audio Drivers Properties dialog box, click the **Properties** tab.
- Step 20** Expand **Audio Devices**.
- Step 21** Click **Audio for Dialogic WAVE**.
- Step 22** Click **Remove**. The Legacy Audio Drivers Properties dialog box closes.
- Step 23** Click **Yes** to confirm.
- Step 24** When prompted to restart the server, click **Don’t Restart Now**.
- 
- 
- Caution** If you restart now, the WAVE driver is not removed.
- 
- Step 25** Click **OK** to close the Legacy Audio Drivers Properties dialog box.
- Step 26** Click **OK** to close the Sounds and Multimedia Properties dialog box.
- Step 27** Close Control Panel.
- Step 28** On the Windows Start menu, click **Programs > Dialogic System Software > Uninstall**.

- Step 29** Follow the on-screen prompts.  
If you are prompted to delete shared files, click **No to All**.
- Step 30** Click **OK**.
- Step 31** At the end of the uninstall, click **Yes** to restart the server. (The Dialogic-triggered restart may not restart the session; in this case, manually restart.)
- Step 32** After the system restarts, log on.
- Step 33** In Windows Explorer, browse to the directory where Cisco Unity is installed (the default directory is CommServer), and delete the Dialogic directory.
- 

## Resetting the Intel Dialogic Quiet Parameter

After you reinstall Intel Dialogic voice card software, do the following procedure to reset the quiet parameter to the value you identified in the [“Determining the Current Setting for the Intel Dialogic Quiet Parameter”](#) section on page A-11.

### To Reset the Intel Dialogic Quiet Parameter

---

- Step 1** Exit the Cisco Unity software, if it is running. For more information, see [Appendix B, “Exiting and Starting the Cisco Unity Software and Server.”](#)
- Step 2** Click **Programs > Administrative Tools > Services**.
- Step 3** In the right pane of the Services dialog box, right-click **Telephony**, and click **Stop**.
- Step 4** If you are prompted to stop other services, click **Yes**.
- Step 5** On the Windows Start menu, click **Programs > Dialogic System Software > Dialogic Configuration Manager–DCM**.
- The tree-structured list contains an entry for each Intel Dialogic card installed in the server.
- Step 6** On the Service menu, click **Stop Service**.
- Step 7** Double-click a card in the tree list.
- Step 8** In the Properties dialog box for the card, click the **Misc** tab.
- Step 9** Under Parameter, click **ParameterFile**.
- Step 10** In the Value box, enter the values that you recorded in [Step 9](#) of the procedure [“To Determine the Current Setting for the Intel Dialogic Quiet Parameter”](#) procedure on page A-11, in the format **quiet<XX>.prm** (where XX = the -dBm level of the desired quiet parameter file). The default setting is 50. If spandti.prm or any other values existed in the box, re-enter each value followed by a space, then enter **quiet<XX>.prm** as the last value in the box.
- Step 11** Click **OK**.
- Step 12** Repeat [Step 7](#) through [Step 11](#) for each additional card.
- Step 13** Restart the Cisco Unity server.
-

