



Cisco CallManager 3.2 Integration Guide for Cisco Unity 4.0

Revised November 14, 2005

This document provides instructions for integrating the phone system with Cisco Unity.

Integration Tasks

Before doing the following tasks to integrate Cisco Unity with the Cisco CallManager phone system, confirm that the Cisco Unity server is ready for the integration by completing the applicable tasks in the *Cisco Unity Installation Guide*.

The following task lists describe the process for creating, changing, and deleting integrations.

Task List to Create the Integration

Use the following task list to set up a new integration with the Cisco CallManager phone system. If you are installing a new Cisco Unity server by using the *Cisco Unity Installation Guide*, you may have already completed some of the following tasks.

1. Review the system and equipment requirements to confirm that all phone system and Cisco Unity server requirements have been met. See the [“Requirements” section on page 2](#).
2. Plan how the voice messaging ports will be used by Cisco Unity. See the [“Planning How the Voice Messaging Ports Will Be Used by Cisco Unity” section on page 5](#).
3. Program Cisco CallManager. See the [“Programming the Cisco CallManager Phone System” section on page 7](#).
 - When configuring voice mail ports for a Cisco Unity server without failover or the primary server with failover, do all the procedures in this section.
 - When configuring voice mail ports for a secondary server with failover, do only the [“To Add Voice Mail Ports to Cisco CallManager”](#) procedure.
4. Set up the gateways that service Cisco Unity. See the [“Setting Up the Gateways That Service Cisco Unity” section on page 17](#).



Corporate Headquarters:
Cisco Systems, Inc., 170 West Tasman Drive, San Jose, CA 95134-1706 USA

Copyright © 2004 Cisco Systems, Inc. All rights reserved.

5. Create the integration. See the [“Creating a New Integration with the Cisco CallManager Phone System” section on page 17.](#)
6. Test the integration. See the [“Testing the Integration” section on page 23.](#)
7. If you have a secondary server for Cisco Unity failover, integrate the secondary server. See the [“Integrating a Secondary Server for Cisco Unity Failover” section on page 27.](#)

Task List to Make Changes to an Integration

Use the following task list to make changes to an integration after it has been created.

1. Start the Cisco Unity Telephony Integration Manager (UTIM). See the [“Changing the Settings for an Existing Integration” section on page 30.](#)
2. Make the changes you want to the existing integration. See the [“Changing the Settings for an Existing Integration” section on page 30.](#)

Task List to Change the Number of Voice Messaging Ports

Use the following task list to change the number of voice messaging ports for an integration after it has been created.

1. Change the number of voice messaging ports. See the [“Changing the Number of Voice Messaging Ports” section on page 30.](#)
2. Start the Cisco Unity Telephony Integration Manager (UTIM). See the [“Changing the Settings for an Existing Integration” section on page 30.](#)
3. Make the changes you want to the existing integration. See the [“Changing the Settings for an Existing Integration” section on page 30.](#)

Task List to Delete an Existing Integration

Use the following task list to remove an existing integration.

1. Start the Cisco Unity Telephony Integration Manager (UTIM). See the [“Deleting an Existing Integration” section on page 31.](#)
2. Delete the existing integration. See the [“Deleting an Existing Integration” section on page 31.](#)

Requirements

The Cisco CallManager integration supports configurations of the following components:

Phone System

- A Cisco IP telephony applications server consisting of Cisco CallManager 3.2(1) or later, running on a Cisco Media Convergence Server (MCS) or customer-provided server meeting approved Cisco configuration standards.
- Cisco licenses for all phone lines, IP phones, and other H.323-compliant devices or software (such as Cisco VirtualPhone and Microsoft NetMeeting clients) that will be connected to the network, as well as one license for each Cisco Unity port.

- IP phones for the Cisco CallManager extensions.
- A LAN connection in each location where you will plug an IP phone into the network.
- For multiple Cisco CallManager clusters, subscribers can dial an extension on another Cisco CallManager cluster without having to dial a trunk access code or prefix.

Cisco Unity Server

- Cisco Unity version 4.0(1) or later, installed and ready for the integration as described in the *Cisco Unity Installation Guide*.
- A license that enables the applicable number of voice messaging ports.

Integration Description

The Cisco CallManager integration uses the LAN to connect Cisco Unity and the phone system. The gateway provides connections to the PSTN. [Figure 1](#) shows the connections.

Figure 1 Connections Between the Phone System and Cisco Unity

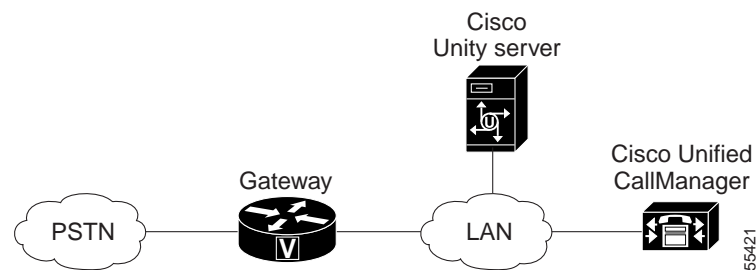

Call Information

The phone system sends the following information with forwarded calls:

- The extension of the called party
- The extension of the calling party (for internal calls) or the phone number of the calling party (if it is an external call and the system uses caller ID)
- The reason for the forward (the extension is busy, does not answer, or is set to forward all calls)

Cisco Unity uses this information to answer the call appropriately. For example, a call forwarded to Cisco Unity is answered with the personal greeting of the subscriber. If the phone system routes the call to Cisco Unity without this information, Cisco Unity answers with the opening greeting.

Integration Features

The Cisco CallManager integration with Cisco Unity provides the following features.

Call forward to personal greeting	When an incoming call is routed to an unanswered extension, the call is forwarded to the voice mail of the subscriber. The caller then hears the personal greeting of the subscriber and can leave a message.
Call forward to busy greeting	When an incoming call is routed to a busy extension, the call is forwarded to the voice mail of the subscriber. The caller then hears the busy greeting (if the subscriber enabled it) and can leave a message.
Caller ID	Cisco Unity receives caller ID information from the phone system (if available). This information appears in the subject line of the message in the desktop messaging application.
Easy message access	A subscriber can retrieve messages without entering an ID. Cisco Unity identifies a subscriber based on the extension from which the call originated. A password may be required.
Identified subscriber messaging	Cisco Unity automatically identifies a subscriber who leaves a message during a forwarded internal call, based on the extension from which the call originated.
Message waiting indication	When a message is waiting for a subscriber, Cisco Unity notifies Cisco CallManager to activate the message waiting indicator (MWI) on the subscriber extension.

When a Cisco Survivable Remote Site Telephony (SRST) router is part of the network and the Cisco SRST router takes over call processing functions (for example, because the WAN link is down), the Cisco SRST integration with Cisco Unity has the following feature limitations:

- **Call forward to busy greeting**—When the Cisco SRST router uses FXO/FXS connections to the PSTN and a call is forwarded from a branch office to Cisco Unity, the busy greeting cannot play.
- **Call forward to internal greeting**—When the Cisco SRST router uses FXO/FXS connections to the PSTN and a call is forwarded from a branch office to Cisco Unity, the internal greeting cannot play. Because the PSTN provides the calling number of the FXO line, the caller is not identified as a subscriber.
- **Call transfers**—Because an access code is needed to reach the PSTN, call transfers from Cisco Unity to a branch office will fail.
- **Identified subscriber messaging**—When the Cisco SRST router uses FXO/FXS connections to the PSTN and a subscriber at a branch office leaves a message or forwards a call, the subscriber is not identified. The caller appears as an unidentified caller.
- **Message waiting indication**—MWIs are not updated on branch office phones. So MWIs will not correctly reflect when new messages arrive or when all messages have been listened to. We recommend resynchronizing MWIs after the WAN link is reestablished.
- **Message notification**—Because an access code is needed to reach the PSTN, message notifications from Cisco Unity to a branch office will fail.
- **Routing rules**—When the Cisco SRST router uses FXO/FXS connections to the PSTN and a call arrives from a branch office to Cisco Unity (either a direct or forwarded call), routing rules will fail.

When the Cisco SRST router uses PRI/BRI connections, the caller ID for calls from a branch office to Cisco Unity may be the full number (exchange plus extension) provided by the PSTN and therefore may not match the extension of the Cisco Unity subscriber. If this is the case, you can let Cisco Unity recognize the caller ID by using alternate extensions (for instructions, see the “Appendix: Using Alternate Extensions and MWIs” section) or by using extension remapping (for instructions, refer to the “Remapping Extension Numbers” section of the “System Settings” chapter in the applicable *Cisco Unity System Administration Guide* (release 4.0(3) or later), available at http://www.cisco.com/en/US/products/sw/voicesw/ps2237/products_administration_guides_list.html.

For information on setting up Cisco SRST routers, refer to the “Integrating Voice Mail with Cisco SRST” section of the “Cisco SRST System Administrator Guide,” available at <http://www.cisco.com/univercd/cc/td/doc/product/software/ios122/122newft/122limit/122z/122zj15/index.htm>.

Integrations with Two Phone Systems

Cisco Unity can be integrated with two phone systems at one time. For information on and instructions for integrating Cisco Unity with two phone systems, see the *Dual Phone System Integration Guide*, available at http://www.cisco.com/univercd/cc/td/doc/product/voice/c_unity/integuid/multi/itmultipin.htm.

Having two integrations requires that an adequate number of voice messaging ports on the Cisco Unity server are connected to the phone systems. This number of ports must not exceed the maximum number of ports that are enabled by the Cisco Unity license files.

Planning How the Voice Messaging Ports Will Be Used by Cisco Unity

Before programming the phone system, you need to plan how the voice messaging ports will be used by Cisco Unity. The following considerations will affect the programming for the phone system (for example, setting up the hunt group or call forwarding for the voice messaging ports):

- The number of voice messaging ports installed.
- The number of voice messaging ports that will answer calls.
- The number of voice messaging ports that will only dial out, for example, to send message notification, to set message waiting indicators (MWIs), to make AMIS deliveries, and to make telephone record and playback (TRAP) connections.
- The number of voice messaging ports that will be dedicated to set MWIs if Cisco Unity is connected to multiple clusters of Cisco CallManager and if the Cisco CallManager server has dedicated MWI voice messaging ports.

Table 1 describes the voice messaging port settings in Cisco Unity that can be set in UTIM and are displayed as read-only text on the System > Ports page of the Cisco Unity Administrator.

Table 1 Settings for the Voice Messaging Ports

Field	Considerations
Extension	Enter the extension for the port as assigned on the phone system.
Enabled	Check this check box to enable the port. The port is enabled during normal operation. Uncheck this check box to disable the port. When the port is disabled, calls to the port get a ringing tone but are not answered. Typically, the port is disabled only by the installer during testing.
Answer Calls	Check this check box to designate the port for answering calls. These calls can be incoming calls from unidentified callers or from subscribers. As a general guideline, set Answer Calls on approximately 75 percent of the ports.
Message Notification	Check this check box to designate the port for notifying subscribers of messages. Assign Message Notification to the least busy ports, which typically are those with the highest port numbers for the phone system. As a general guideline, set Message Notification, Dialout MWI, and TRAP Connection on approximately 25 percent of the ports.
Dialout MWI <i>(not used by serial or SMDI integrations)</i>	Check this check box to designate the port for turning MWIs on and off. Assign Dialout MWI to the least busy ports, which typically are those with the highest port numbers for the phone system. As a general guideline, set Message Notification, Dialout MWI, and TRAP Connection on approximately 25 percent of the ports.
AMIS Delivery <i>(available with the AMIS licensed feature only)</i>	Check this check box to designate the port for making outbound AMIS calls to deliver voice messages from Cisco Unity subscribers to users on another voice messaging system. Cisco Unity supports the Audio Messaging Interchange Specification (AMIS) protocol, which provides an analog mechanism for transferring voice messages between different voice messaging systems. This setting affects outbound AMIS calls only. All ports are used for incoming AMIS calls. Because the transmission of outgoing AMIS messages may tie up voice ports for long periods of time, you may want to adjust the schedule on the Network > AMIS > Schedule page so that outgoing AMIS calls are placed during closed hours or at times when Cisco Unity is not processing many calls.
TRAP Connection	Check this check box so that subscribers can use the phone as a recording and playback device in Cisco Unity web applications and e-mail clients. Assign TRAP Connection to the least busy ports, which typically are those with the highest port numbers for the phone system. As a general guideline, set Message Notification, Dialout MWI, and TRAP Connection on approximately 25 percent of the ports.

The Number of Voice Messaging Ports to Install

The number of voice messaging ports to install depends on numerous factors, including:

- The number of calls Cisco Unity will answer when call traffic is at its peak.
- The expected length of each message that callers will record and that subscribers will listen to.
- The number of subscribers.
- The number of ports that will be set to dial out only.
- The number of calls made for message notification.
- The number of MWIs that will be activated when call traffic is at its peak.
- The number of AMIS delivery calls.

- The number of TRAP connections needed when call traffic is at its peak. (TRAP connections are used by Cisco Unity web applications and e-mail clients to play back and record over the phone.)

It is best to install only the number of voice messaging ports that are needed so that system resources are not allocated to unused ports.

The Number of Voice Messaging Ports That Will Answer Calls

The calls that the voice messaging ports answer can be incoming calls from unidentified callers or from subscribers. Typically, these voice messaging ports are the busiest. They also have the lowest port numbers for the phone system.

You can set voice messaging ports to both answer calls and to dial out (for example, to send message notifications).

The Number of Voice Messaging Ports That Will Only Dial Out, and Not Answer Calls

Ports that will only dial out and will not answer calls can do one or more of the following:

- Notify subscribers by phone, pager, or e-mail of messages that have arrived.
- Turn MWIs on and off for subscriber extensions.
- Make outbound AMIS calls to deliver voice messages from Cisco Unity subscribers to users on another voice messaging system. (This action is available only with the AMIS licensed feature.)
- Make a TRAP connection so that subscribers can use the phone as a recording and playback device in Cisco Unity web applications and e-mail clients.

Typically, these voice messaging ports are the least busy ports. They also have the highest port numbers for the phone system.



Caution

In programming the phone system, do not send calls to voice messaging ports in Cisco Unity that cannot answer calls (voice messaging ports that are not set to Answer Calls). For example, if a voice messaging port is set only to Dialout MWI, do not send calls to it.

The Number of Voice Messaging Ports That Will Be Dedicated to Activating MWIs on Other Cisco CallManager Clusters

If Cisco Unity services multiple clusters of Cisco CallManager, there must be at least one voice messaging port per cluster dedicated for turning MWIs on and off for each cluster. For example, if the system has four clusters, at least four ports on Cisco Unity must be dedicated to activating MWIs, one port for each cluster.

Preparing for Programming the Phone System

Record your decisions about the voice messaging ports to guide you in programming the phone system.

Programming the Cisco CallManager Phone System

After Cisco CallManager software is installed, do the procedures in this section to program Cisco CallManager to work with Cisco Unity:

- When configuring voice mail ports for a Cisco Unity server without failover, or the primary server with failover, do all the procedures in this section.

- When configuring voice mail ports for a secondary server with failover, do only the “[To Add Voice Mail Ports to Cisco CallManager](#)” procedure.

To Add Partitions and a Calling Search Space to Contain the Voice Mail Ports

-
- Step 1** In the Cisco CallManager Administration, click **Route Plan > Partition**.
- Step 2** Click **Add a New Partition**.
- Step 3** Enter the name and description you want for the partition that will contain all voice mail port directory numbers except for the first voice mail port, which will be assigned the voice mail pilot number. For example, enter “VMRestrictedPT, Partition for voice mail port directory numbers.” For a diagram of the configuration, see [Figure 2](#). For a diagram of the configuration with Cisco Unity failover, see [Figure 3](#).
- Step 4** Click **Insert**.
- Step 5** Click **Add a New Partition**.
- Step 6** Enter the name and description you want for the partition that will contain the directory number of the first voice mail port, which will be assigned the voice mail pilot number. For example, enter “VMPilotNumberPT, Partition for the voice mail pilot number.” For a diagram of the configuration, see [Figure 2](#). For a diagram of the configuration with Cisco Unity failover, see [Figure 3](#).
- Step 7** Click **Insert**.
- Step 8** Click **Route Plan > Calling Search Space**.
- Step 9** Click **Add a New Calling Search Space**.
- Step 10** In the Calling Search Space Name field, enter a name for the calling search space that will include the partition created in [Step 2](#) through [Step 4](#). For example, enter “VMRestrictedCSS.”
- Step 11** If you want, in the Description field, enter a description of the calling search space. For example, enter “Voice mail port directory numbers.”
- Step 12** In the Available Partitions field, double-click the name of the partition created in [Step 2](#) through [Step 4](#). For example, double-click “VMRestrictedPT.” For a diagram of the configuration, see [Figure 2](#). For a diagram of the configuration with Cisco Unity failover, see [Figure 3](#).
- The name of the partition appears in the Selected Partitions field.
- Step 13** Click **Insert**.
- Step 14** Click **Back to Find/List Calling Search Spaces**.
- Step 15** Click the name of the calling search space that is used by subscriber phones.
- Step 16** In the Available Partitions field, double-click the name of the partition created in [Step 5](#) through [Step 7](#). For example, double-click “VMPilotNumberPT.” For a diagram of the configuration, see [Figure 2](#). For a diagram of the configuration with Cisco Unity failover, see [Figure 3](#).
-  **Caution** If the partition that contains the voice mail pilot number is not in the calling search space that is used by subscriber phones, the phones will not be able to dial the Cisco Unity server.
-
- Step 17** Click **Update**.
- Step 18** Repeat [Step 15](#) through [Step 17](#) for each remaining calling search space that needs to access Cisco Unity.
-

Figure 2 Partitions for Voice Mail Port Directory Numbers

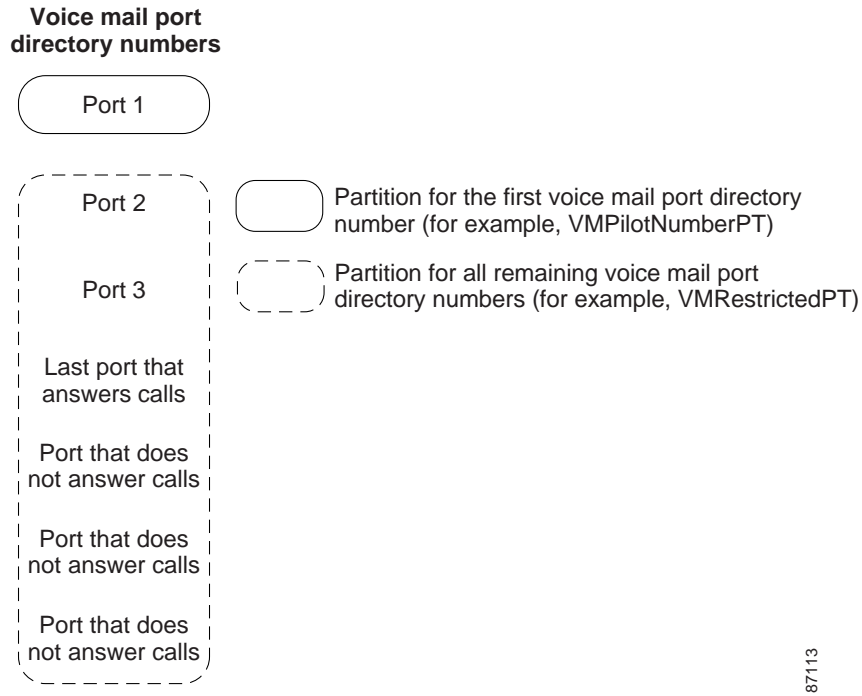
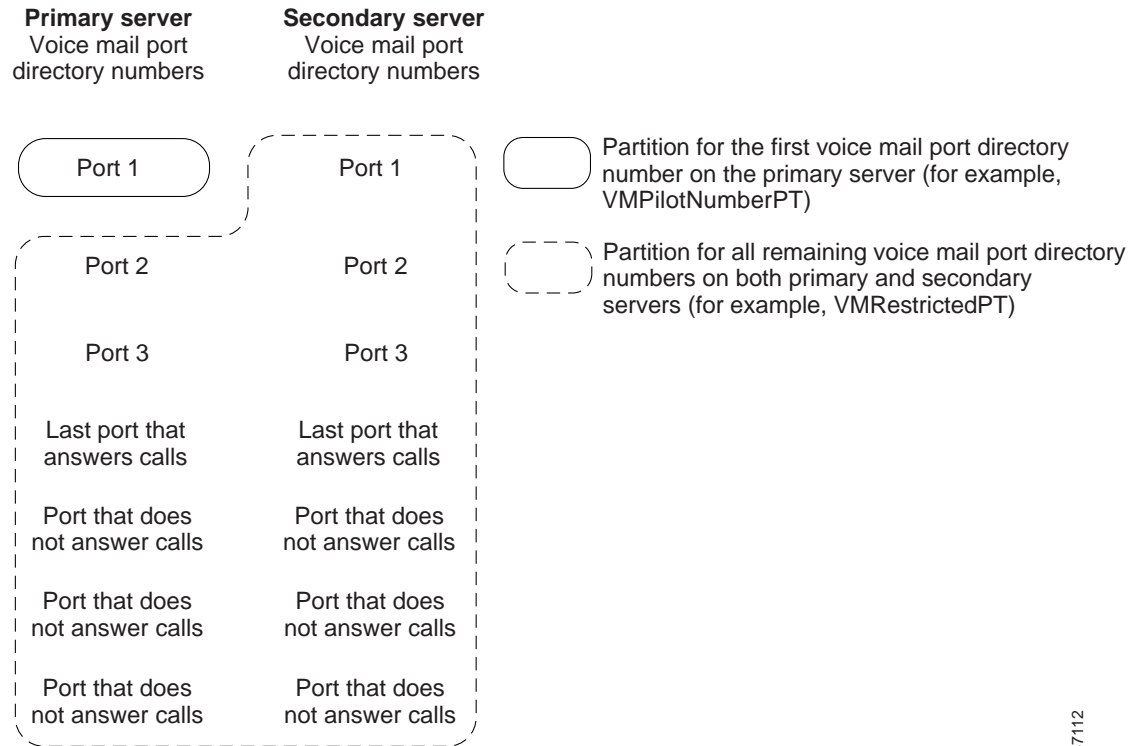

Figure 3 Partitions for Voice Mail Port Directory Numbers with Cisco Unity Failover



To Add a Device Pool for the Voice Mail Ports

- Step 1** In the Cisco CallManager Administration, click **System > Device Pool**.
- Step 2** On the Device Pool Configuration page, enter the following device pool settings.

Table 2 Settings for the Device Pool Configuration Page

Field	Setting
Device Pool Name	Enter Cisco Unity Voice Mail Ports or other description for this device pool.
Cisco CallManager Group	Click the Cisco CallManager group to assign to the voice mail ports in this device pool.
Date/Time Group	Click the date/time group to assign to the voice mail ports in this device pool.
Region	Click the Cisco CallManager region to assign to the voice mail ports in this device pool.
Softkey Template	Click the softkey template to assign to the voice mail ports in this device pool.
SRST Reference	Click the survivable remote site telephony (SRST) reference to assign to the voice mail ports in this device pool.
Network Hold MOH Audio Source	Click None .
User Hold MOH Audio Source	Click None .

- Step 3** Click **Insert**.

To Add Voice Mail Ports to Cisco CallManager

Add a voice mail port to Cisco CallManager for each port that you are connecting to Cisco Unity.

- Step 1** In the Cisco CallManager Administration, click **Feature > Voice Mail > Cisco Voice Mail Port Wizard**.
- Step 2** Click **Create a New Cisco Voice Mail Server and Add Ports to It** and click **Next**.
- Step 3** The name of the voice mail server appears. We recommend that you accept the default name for the voice mail server, or, if necessary, enter a different name with no more than nine characters, then click **Next**. The default name (CiscoUM), even if you do not use it, becomes part of the name for ports as follows: <the voice mail server name>1 (for example, CiscoUM1).



Caution

If Cisco Unity is configured for failover, the name of the voice mail server and voice mail ports that serve the secondary server must be different from the name of the voice mail server and voice mail ports that serve the primary server. Otherwise, the secondary server cannot function correctly.

- Step 4** Enter the number of ports you want to add (which must not be more ports than the Cisco Unity license enables), then click **Next**.

If you will integrate Cisco Unity with multiple clusters of Cisco CallManager, the number you enter here cannot bring the total number of ports on all clusters integrated with Cisco Unity to more than the number of ports enabled by the Cisco Unity license.

- Step 5** Enter the following voice mail device settings, then click **Next**.

Table 3 *Settings for the Voice Mail Devices*

Field	Setting
Description	Enter Cisco Voice Mail Port or other description that you want.
Device Pool	Click the name of the device pool you created for the voice mail ports. For example, click Cisco Unity Voice Mail Ports.
Calling Search Space	Click the name of a calling search space that allows calls to the subscriber phones and any required network devices. This calling search space must include partitions that contain all devices Cisco Unity needs to access (for example, during call transfers, message notifications, and MWI activations).
Location	Accept the default of None .

- Step 6** Enter the following voice mail directory number settings, then click **Next**.

Table 4 *Settings for the Voice Mail Directory Numbers*

Field	Setting
Pilot Number	Enter the pilot number for the voice mail ports. The pilot number is the extension number of the first voice mail port and is the number subscribers enter to listen to their voice messages. If Cisco Unity is configured for failover and you are adding voice mail ports for the secondary server, the pilot number is the extension number of the first voice mail port on the secondary server, but it is not the number subscribers enter to listen to their voice messages.
Partition	Click the name of the partition that you set up for all voice mail port directory numbers except the first voice mail port. For example, click "VMRestrictedPT."

Table 4 Settings for the Voice Mail Directory Numbers (continued)

Calling Search Space	<p>Click the name of a calling search space that you set up to contain the partition with all voice mail port directory numbers except the first voice mail port, as set in Step 9 of the “To Add Partitions and a Calling Search Space to Contain the Voice Mail Ports” section on page 8. For example, click “VMRestrictedCSS.”</p> <p>Because this calling search space is not used by subscriber phones, subscribers cannot dial any voice mail ports except the voice mail pilot number.</p>
Display	<p>Accept the default of Voicemail. (This text appears on the phone when the pilot number is dialed.)</p> <hr/> <p> Caution If Cisco Unity is configured for failover, do not change the default setting for this field. Otherwise, the integration will not function correctly.</p>

- Step 7** Enter the operator number or the number you want the last port to forward to when busy, if applicable, and click **Next**.
- Step 8** The settings for the new ports appear. Click **Finish**.
- Step 9** Click **Go to Cisco Voice Mail Ports Page**.



Note If Cisco Unity is configured for failover and you are setting ports for the secondary server, skip the remaining procedures in this section and continue to the “[Creating a New Integration with the Cisco CallManager Phone System](#)” section on page 17. For further instructions on configuring the voice mail ports, see the “[Integrating a Secondary Server for Cisco Unity Failover](#)” section on page 27.

To Set the Partition for the First Voice Mail Port

- Step 1** On the Cisco Voice Mail Port Configuration page, in the Cisco Voice Mail Ports list, click the first voice mail port, which is assigned the voice mail pilot number.
- Step 2** Under Directory Number Information, in the Partition field, click the partition that you set up to contain the first voice mail port. For example, click “VMPilotNumberPT.”
- Step 3** Click **Update**.

To Specify MWI Directory Numbers

- Step 1** In the Cisco CallManager Administration, click **Feature > Voice Mail > Message Waiting**.
- Step 2** In the Message Waiting Directory Numbers list of the Message Waiting Configuration page, click **Add a New Directory Number**.
- Step 3** Enter the following settings for turning MWIs on.

Table 5 Settings for Turning MWIs On

Field	Setting
Directory Number	Enter the unique extension that turns MWIs on.
Message Waiting Indicator	Click On .
Partition	Click the name of the partition that you set up for the first voice mail port. For example, click “VMPilotNumberPT.”
Calling Search Space	Click a calling search space that is used by subscriber phones.

Step 4 Click **Insert**.

Step 5 In the Message Waiting Directory Numbers list, click **Add a New Directory Number**.

Step 6 Enter the following settings for turning MWIs off.

Table 6 Settings for Turning MWIs Off

Field	Setting
Directory Number	Enter the unique extension that turns MWIs off.
Message Waiting Indicator	Click Off .
Partition	Click the name of the partition that you set up for the first voice mail port. For example, click “VMPilotNumberPT.”
Calling Search Space	Click a calling search space that is used by subscriber phones.

Step 7 Click **Insert**.

To Add a Voice Mail Pilot Number for the Voice Mail Ports

The voice mail pilot number is the extension that you dial to listen to your voice messages. Your Cisco IP phone automatically dials the voice mail pilot number when you press the Messages button.

Step 1 In the Cisco CallManager Administration, click **Feature > Voice Mail > Voice Mail Pilot**.

Step 2 In the Voice Mail Pilot Numbers list of the Voice Mail Pilot Configuration page, click **Add a New Voice Mail Pilot Number**.

Step 3 Enter the following voice mail pilot number settings.

Table 7 Settings for the Voice Mail Pilot Number

Field	Setting
Voice Mail Pilot Number	Enter the pilot number for the voice mail ports. This number must be the same pilot number that you entered when adding voice mail ports earlier. The pilot number is typically the extension number of the first voice mail port and is the number subscribers enter to listen to their voice messages.
Description	Enter Cisco Unity Pilot or another description that you want.

Table 7 Settings for the Voice Mail Pilot Number (continued)

Calling Search Space	Click the calling search space that includes partitions containing the subscriber phones and the partition you set up for the first voice mail port.
Make This the Default Voice Mail Pilot for the System	Check this check box. When this check box is checked, this voice mail pilot number replaces the current default pilot number.

Step 4 Click **Insert**.

To Set Up the Voice Mail Profile

Step 1 In the Cisco CallManager Administration, click **Feature > Voice Mail > Voice Mail Profile**.

Step 2 In the Find and List Voice Mail Profiles page, click **Add a New Voice Mail Profile**.

Step 3 In the Voice Mail Profiles Configuration page, enter the following voice mail profile settings.

Table 8 Settings for the Voice Mail Profile

Field	Setting
Voice Mail Profile Name	Enter a name to identify the voice mail profile.
Description	Enter Cisco Unity Profile or another description that you want.
Voice Mail Pilot	Click one of the following: <ul style="list-style-type: none"> The applicable voice mail pilot number that you defined in the Voice Mail Pilot Configuration None (to use the default voice mail pilot number)
Voice Mail Box Mask	When multitenant services are not enabled on Cisco CallManager, leave this field blank. When multitenant services are enabled, each tenant uses its own voice mail profile. Create a mask to identify the extensions (directory numbers) in each partition. For example, one tenant can use a mask 972813XXXX, while another tenant can use the mask 214333XXXX. It is also necessary to set up translation patterns for MWIs.
Make This the Default Voice Mail Profile for the System	Check this check box to make this voice mail profile the default. If you check the check box, this voice mail profile replaces the current default voice mail profile.

Step 4 Click **Insert**.

To Set Up the Voice Mail Server Service Parameters

Step 1 In the Cisco CallManager Administration, click **Service > Service Parameters**.

- Step 2** In the Server field on the Service Parameters Configuration page, click the voice mail server that you created earlier.
- Step 3** In the Services list, click **Cisco CallManager**. The list of parameters appears.
- Step 4** Scroll down the list until you locate the parameters listed in [Table 9](#) (about three-quarters of the way).
- Step 5** Enter the parameter settings shown in the following table.

Table 9 Settings for the Service Parameters

Service Parameter to Configure	Setting
Voice Mail Maximum Hop Count	Used together with AdvancedCallForwardHopFlag, the maximum number of voice mail ports skipped to find the next available voice mail port. Specify a value that is three less than the number of Cisco CallManager ports that are connected to the Cisco Unity server. For example, if you have a 48-port Cisco Unity system, enter 45 for this setting. If you have configured failover for Cisco Unity, specify a value that is three less than the total number of Cisco CallManager ports that are connected to both Cisco Unity servers. For example, if the primary and secondary Cisco Unity servers each have 48 ports, enter 93 for this setting.
Multiple Tenant MWI Modes	Enables multitenant MWI notification. When set to True, Cisco CallManager uses any configured translation patterns to convert voice mail extensions into directory numbers when turning on or off an MWI.
H225 DTMF Duration	Specifies the duration (in milliseconds) of outbound DTMF digits for H.323 devices. If you will use the Cisco Unity Bridge or AMIS to connect Cisco CallManager and Cisco Unity to a supported third-party voice messaging system, confirm that this parameter is set to 100 .
Advanced CallForward Hop Flag	Enables Cisco CallManager to skip busy or unregistered voice mail ports when searching for an available voice mail port. Set to True .

- Step 6** Click **Update** to save the settings.
- Step 7** Click **Select Another Service** at the top of the page.
- Step 8** In the Services list, click **Cisco Messaging Interface**. The list of parameters appears.
- Step 9** Confirm that the VoiceMailDn parameter setting is blank.
- Step 10** If you changed the parameter setting to blank, click **Update** to save the setting.
- Step 11** Shut down and restart the Cisco CallManager server.

If the plan for voice mail ports in Cisco Unity (see the [“Planning How the Voice Messaging Ports Will Be Used by Cisco Unity”](#) section on page 5) includes ports that do not answer calls (for example, ports that only dial out to set MWIs), do the following procedure so that incoming calls are not forwarded to these ports.

To Set Up Voice Mail Ports So Incoming Calls Are Forwarded Only to Answering Ports

- Step 1** In the Cisco CallManager Administration, click **Feature > Voice Mail > Cisco Voice Mail Port**.
 - Step 2** In the Cisco Voice Mail Ports list of the Cisco Voice Mail Port Configuration page, click the name of the last voice mail port that answers calls in Cisco Unity.
 - Step 3** Set the Forward Busy and Forward No Answer fields to forward to the first voice mail port that answers calls in Cisco Unity.
 - Step 4** Click **Update**.
 - Step 5** In the Cisco Voice Mail Ports list, click the name of a the first voice mail port that does not answer calls in Cisco Unity.
 - Step 6** Under Call Forwarding Information, delete the extensions in the Forward Busy field, and set the Forward No Answer field to forward to the first voice mail port that answers calls in Cisco Unity.
 - Step 7** Click **Update**.
 - Step 8** Repeat [Step 5](#) through [Step 7](#) for all remaining voice mail ports that do not answer calls in Cisco Unity.
-

If the Cisco Unity server services multiple clusters of Cisco CallManager, do the following procedure to enable MWIs to be activated on extensions in each cluster.

To Set Up MWI Voice Mail Ports for Multiple Clusters of Cisco CallManager

- Step 1** In the Cisco Unity Administrator, select at least one voice mail port per cluster to be dedicated for sending MWIs to each cluster. For example, if the system has four clusters, dedicate at least four ports to send only MWIs, one port from each cluster.
 - Step 2** In the Cisco CallManager Administration, click **Feature > Voice Mail > Cisco Voice Mail Port**.
 - Step 3** In the Cisco Voice Mail Ports list of the Cisco Voice Mail Port Configuration page, click the name of the port before the first dedicated MWI port.
 - Step 4** Under Call Forwarding Information, change the extensions to the number of the first voice mail port or of the operator.
 - Step 5** Click **Update**.
 - Step 6** In the Cisco Voice Mail Ports list, click the name of a dedicated MWI port.
 - Step 7** Under Call Forwarding Information, delete the extensions so that the fields are empty and call forwarding for this port is disabled.
 - Step 8** Click **Update**.
 - Step 9** Repeat [Step 6](#) through [Step 8](#) for all remaining dedicated MWI ports.
-

You can use alternate extensions to create multiple line appearances, enable easy message access from cell phones, and simplify addressing messages to subscribers at different locations in Cisco Unity. When you enable alternate MWIs, Cisco Unity can turn MWIs on at more than one extension. For details, see the [“Appendix: Using Alternate Extensions and MWIs”](#) section on page 32.

Setting Up the Gateways That Service Cisco Unity

In certain situations, DTMF digits are not recognized when processed through VoIP dial-peer gateways. To avoid this problem, certain gateways must be configured to enable DTMF relay. The DTMF relay feature is available in Cisco IOS software version 12.0(5) and later.

Cisco IOS software-based gateways that use H.245 out-of-band signaling must be configured to enable DTMF relay.

Enable `dtmf-relay h245-alphanumeric` on this dial-peer.

The Catalyst 6000 T1/PRI and FXS gateways enable DTMF relay by default and do not need additional configuration to enable this feature.

To Enable DTMF Relay

-
- Step 1** On a VoIP dial-peer servicing Cisco Unity, use the following command:
- ```
dtmf-relay h245-alphanumeric
```
- Step 2** Create a destination pattern that matches the Cisco CallManager voice mail port numbers. For example, if the system has voice mail ports 1001 through 1016, enter the dial-peer destination pattern **10xx**.
- Step 3** Repeat [Step 1](#) and [Step 2](#) for all remaining VoIP dial-peers servicing Cisco Unity.
- 

# Creating a New Integration with the Cisco CallManager Phone System

After ensuring that the Cisco CallManager phone system and the Cisco Unity server are ready for the integration, do the following procedures to set up the integration and to enter the port settings.



## Note

If you are integrating with multiple clusters of Cisco CallManager, you must integrate Cisco Unity with each additional cluster. Skip to the [“To Create an Integration with a Second Cluster of Cisco CallManager”](#) procedure on page 21.

## To Create an Integration

- 
- Step 1** If UTIM is not already open, on the Windows Start menu, click **Programs > Cisco Unity > Manage Integrations**. UTIM appears.
- Step 2** On the Integration menu of the UTIM window, click **New**. The Telephony Integration Setup Wizard appears.
- Step 3** On the Welcome page, click **Cisco CallManager**, then click **Next**.
- Step 4** On the Name Cisco CallManager Integration and Cluster page, enter the following settings, then click **Next**.

**Table 10** Settings for the Name Cisco CallManager Integration and Cluster Page

| Field            | Setting                                                                                                               |
|------------------|-----------------------------------------------------------------------------------------------------------------------|
| Integration Name | <the name you will use to identify this Cisco CallManager integration; accept the default name or enter another name> |
| Cluster Name     | <the name you will use to identify this Cisco CallManager cluster; accept the default name or enter another name>     |

**Step 5** On the Enter Cisco CallManager IP Address and Port page, enter the following settings, then click **Next**.

**Table 11** Settings for the Enter Cisco CallManager IP Address and Port Page

| Field           | Setting                                                                                                                                                                                                                                                              |
|-----------------|----------------------------------------------------------------------------------------------------------------------------------------------------------------------------------------------------------------------------------------------------------------------|
| IP Address/Name | <the IP address (or DNS name) of the Cisco CallManager server that you are connecting to Cisco Unity; if you are connecting to a Cisco CallManager cluster, we recommend entering the IP address (or DNS name) of a subscriber (secondary) Cisco CallManager server> |
| TCP Port        | <the TCP port of the Cisco CallManager server that you are connecting to Cisco Unity; we recommend using the default setting>                                                                                                                                        |

You can click **Ping Server** to confirm that the IP address is correct.

**Step 6** On the Enter Secondary Server Settings page, in the IP Address/Name field, enter the IP address (or DNS name) and port of all remaining subscriber (secondary) Cisco CallManager servers in the cluster and of the publisher (primary) Cisco CallManager server. Then click **Add** after entering each so that the IP addresses of all secondary servers appear in the list. If there is only one Cisco CallManager server in the cluster, leave this page blank.

The IP addresses of the subscriber (secondary) Cisco CallManager servers must appear in descending order, so that the subscriber (secondary) Cisco CallManager server at the top of the list is the first to take over call processing functions during failover, and the publishing (primary) Cisco CallManager server is the last.

You can click **Ping Servers** to confirm that the IP addresses are correct.

**Step 7** If you want Cisco Unity to automatically reconnect to the primary Cisco CallManager server after failover has been corrected, check the **Reconnect to Primary Cisco CallManager Server** check box.

**Step 8** Click **Next**.

**Step 9** On the Enter Cisco CallManager MWI Extensions page, enter the following settings, then click **Next**.

**Table 12** Settings for the Enter CallManager MWI Extensions Page

| Field             | Setting                                                                                |
|-------------------|----------------------------------------------------------------------------------------|
| MWI On Extension  | <the extension you specified in Cisco CallManager Administration for turning MWIs on>  |
| MWI Off Extension | <the extension you specified in Cisco CallManager Administration for turning MWIs off> |

**Step 10** On the Set Number of Voice Messaging Ports page, enter the following settings, then click **Next**.

**Table 13** Settings for the Set Number of Voice Messaging Ports Page

| Field                          | Setting                                                                                                                                                                                                                                                                                                                                                                                                                                                                                                                                                                |
|--------------------------------|------------------------------------------------------------------------------------------------------------------------------------------------------------------------------------------------------------------------------------------------------------------------------------------------------------------------------------------------------------------------------------------------------------------------------------------------------------------------------------------------------------------------------------------------------------------------|
| Number of Ports                | <the number of voice messaging ports connecting Cisco Unity to the Cisco CallManager server; if Cisco Unity is connected to a single Cisco CallManager server, this number cannot be more than the number of ports set up on Cisco CallManager; if Cisco Unity is connected to multiple clusters of Cisco CallManager, this number cannot be more than the number of ports set up on the Cisco CallManager cluster, and the total number of ports on all clusters connected to Cisco Unity cannot be more than the number of ports enabled by the Cisco Unity license> |
| CallManager Device Name Prefix | <the prefix Cisco CallManager adds to the device name for voice messaging ports; this prefix must match the prefix used by Cisco CallManager>                                                                                                                                                                                                                                                                                                                                                                                                                          |

You can click **Verify** to confirm that the CallManager device name prefix is correct.

**Step 11** If another integration already exists, the Enter Trunk Access Code page appears. Enter the extra digits that Cisco Unity must use to transfer calls through the gateway to extensions on the other phone system with which it is integrated. Then click **Next**.

**Step 12** On the Completing page, verify the settings you entered, then click **Finish**.

**Step 13** At the prompt to restart the Cisco Unity services, click **Yes**. The Cisco Unity services restart.

Alternatively, you can restart the Cisco Unity services in UTIM on the Tools menu by clicking **Restart Cisco Unity**. Do not use the taskbar icon to restart the Cisco Unity for UTIM changes because the taskbar icon does not restart all of the Cisco Unity services.

### To Enter the Voice Messaging Port Settings for the Integration

**Step 1** After the Cisco Unity services restart, on the Windows Start menu, click **Programs > Cisco Unity > Manage Integrations**. UTIM appears.

**Step 2** In the left pane of the UTIM window, click the phone system integration you are creating.

**Step 3** In the right pane, click the phone system or cluster name.

**Step 4** In the right pane, click the **Ports** tab.

**Step 5** Enter the settings shown in [Table 14](#) for the voice messaging ports.

For the voice messaging ports assigned to a given Cisco CallManager cluster, to get the best performance use the first voice messaging ports for incoming calls and the last ports to dial out. This helps minimize the possibility of a collision, in which an incoming call arrives on a port at the same time that Cisco Unity takes the port off-hook to dial out. Set the ports assigned to each Cisco CallManager cluster in this manner.

If the Cisco Unity server is connected to multiple clusters of Cisco CallManager and if the Cisco CallManager server has dedicated MWI voice messaging ports, set each dedicated MWI voice messaging port to **Dialout MWI**. For example, if the system has four clusters, dedicate four ports to send only MWIs, and assign one port to each cluster.

**Caution**

In programming Cisco CallManager, do not send calls to voice messaging ports in Cisco Unity that cannot answer calls (voice messaging ports that are not set to Answer Calls). For example, if a voice messaging port is set only to Dialout MWI, do not send calls to it.

**Table 14** Settings for the Voice Messaging Ports

| Field                                                                   | Considerations                                                                                                                                                                                                                                                                                                                                                                                                                                                                                                                                                                                                                                                                                                                                                                       |
|-------------------------------------------------------------------------|--------------------------------------------------------------------------------------------------------------------------------------------------------------------------------------------------------------------------------------------------------------------------------------------------------------------------------------------------------------------------------------------------------------------------------------------------------------------------------------------------------------------------------------------------------------------------------------------------------------------------------------------------------------------------------------------------------------------------------------------------------------------------------------|
| Extension                                                               | Enter the extension for the port as assigned on the phone system.                                                                                                                                                                                                                                                                                                                                                                                                                                                                                                                                                                                                                                                                                                                    |
| Enabled                                                                 | Check this check box to enable the port. The port is enabled during normal operation.<br>Uncheck this check box to disable the port. When the port is disabled, calls to the port get a ringing tone but are not answered. Typically, the port is disabled only by the installer during testing.                                                                                                                                                                                                                                                                                                                                                                                                                                                                                     |
| Answer Calls                                                            | Check this check box to designate the port for answering calls. These calls can be incoming calls from unidentified callers or from subscribers. As a general guideline, set Answer Calls on approximately 75 percent of the ports.                                                                                                                                                                                                                                                                                                                                                                                                                                                                                                                                                  |
| Message Notification                                                    | Check this check box to designate the port for notifying subscribers of messages. Assign Message Notification to the least busy ports, which typically are those with the highest port numbers for the phone system. As a general guideline, set Message Notification, Dialout MWI, and TRAP Connection on approximately 25 percent of the ports.                                                                                                                                                                                                                                                                                                                                                                                                                                    |
| Dialout MWI<br><i>(not used by serial or SMDI integrations)</i>         | Check this check box to designate the port for turning MWIs on and off. Assign Dialout MWI to the least busy ports, which typically are those with the highest port numbers for the phone system. As a general guideline, set Message Notification, Dialout MWI, and TRAP Connection on approximately 25 percent of the ports.                                                                                                                                                                                                                                                                                                                                                                                                                                                       |
| AMIS Delivery<br><i>(available with the AMIS licensed feature only)</i> | Check this check box to designate the port for making outbound AMIS calls to deliver voice messages from Cisco Unity subscribers to users on another voice messaging system. Cisco Unity supports the Audio Messaging Interchange Specification (AMIS) protocol, which provides an analog mechanism for transferring voice messages between different voice messaging systems.<br><br>This setting affects outbound AMIS calls only. All ports are used for incoming AMIS calls. Because the transmission of outgoing AMIS messages may tie up voice ports for long periods of time, you may want to adjust the schedule on the Network > AMIS > Schedule page so that outgoing AMIS calls are placed during closed hours or at times when Cisco Unity is not processing many calls. |
| TRAP Connection                                                         | Check this check box so that subscribers can use the phone as a recording and playback device in Cisco Unity web applications and e-mail clients. Assign TRAP Connection to the least busy ports, which typically are those with the highest port numbers for the phone system. As a general guideline, set Message Notification, Dialout MWI, and TRAP Connection on approximately 25 percent of the ports.                                                                                                                                                                                                                                                                                                                                                                         |

- Step 6** Repeat [Step 5](#) for the remaining clusters, if any.
- Step 7** Click **Save**.
- Step 8** If Cisco Unity integrates with only one cluster of Cisco CallManager, exit UTIM, skip the remaining procedures in this section, and continue to the “Testing the Integration” section.

If Cisco Unity integrates with multiple clusters of Cisco CallManager, continue to the next procedure.

### To Create an Integration with a Second Cluster of Cisco CallManager

If Cisco Unity integrates with only one cluster of Cisco CallManager, skip this procedure.

- Step 1** In the left pane of the UTIM window, click the Cisco CallManager integration.
- Step 2** On the Cluster menu, click **New**. A new cluster appears in the Cisco CallManager integration.
- Step 3** Click the **Servers** tab, and enter the following settings.

**Table 15** Settings for the Servers Tab

| Field                                             | Setting                                                                                                                                                                                                                                                                                                                                                                            |
|---------------------------------------------------|------------------------------------------------------------------------------------------------------------------------------------------------------------------------------------------------------------------------------------------------------------------------------------------------------------------------------------------------------------------------------------|
| Display Name                                      | Enter <b>Cisco CallManager Cluster 02</b> or another name you will use to identify this Cisco CallManager cluster.                                                                                                                                                                                                                                                                 |
| <b>Primary Server</b>                             |                                                                                                                                                                                                                                                                                                                                                                                    |
| IP Address/Name                                   | <the IP address (or DNS name) of a subscriber (secondary) Cisco CallManager server>                                                                                                                                                                                                                                                                                                |
| Port                                              | <the TCP port of the Cisco CallManager server that you are connecting to Cisco Unity; we recommend using the default setting>                                                                                                                                                                                                                                                      |
| CallManager Device Name Prefix                    | <the prefix Cisco CallManager adds to the device name for voice messaging ports; this prefix must match the prefix used by the Cisco CallManager cluster>                                                                                                                                                                                                                          |
| <b>Secondary Servers</b>                          |                                                                                                                                                                                                                                                                                                                                                                                    |
| IP Address/Name                                   | <the IP address (or DNS name) of all remaining subscriber (secondary) Cisco CallManager servers in the cluster and the publisher (primary) Cisco CallManager server; then click <b>Add</b> after entering each so that the IP addresses of all secondary servers appear in the Address list; if there is only one Cisco CallManager server in the cluster, leave this field blank> |
| Port                                              | <the TCP port of the Cisco CallManager server that you are connecting to Cisco Unity; we recommend using the default setting>                                                                                                                                                                                                                                                      |
| Reconnect to the Primary Cisco CallManager server | Check this check box if you want Cisco Unity to automatically reconnect to the primary Cisco CallManager server in the cluster after failover has been corrected.                                                                                                                                                                                                                  |

- Step 4** Click the **MWI** tab, and enter the following settings.

**Table 16** Settings for the MWI Tab

| Field         | Setting                                                                                               |
|---------------|-------------------------------------------------------------------------------------------------------|
| On Extension  | <the extension you specified in Cisco CallManager Administration of the cluster for turning MWIs on>  |
| Off Extension | <the extension you specified in Cisco CallManager Administration of the cluster for turning MWIs off> |

- Step 5** Click the **Ports** tab, and click **Add Port**.
- Step 6** In the Add Port dialog box, enter the number of voice messaging ports on Cisco Unity you want to connect to the Cisco CallManager cluster, and click **OK**.
- This number cannot be more than the number of ports set up on the Cisco CallManager cluster. This number cannot bring the total number of port installed on the Cisco Unity server to more than the number of ports enabled by the Cisco Unity license.
- Step 7** Click the Servers tab, and click **Verify Servers** to confirm that the Cisco CallManager server information is correct.
- Step 8** Click the **RTP** tab, and confirm that the Automatically Assign option is selected.
- Step 9** In the UTIM window, click **Save**.
- Step 10** At the prompt to restart the Cisco Unity services, click **Yes**. The Cisco Unity services restart.



**Note** When restarting Cisco Unity, use the UTIM prompt instead of the Cisco Unity icon in the Windows taskbar. The taskbar icon does not restart all of the Cisco Unity services.

- Step 11** After the Cisco Unity services restart, on the Windows Start menu, click **Programs > Cisco Unity > Manage Integrations**. UTIM appears.
- Step 12** In the left pane of the UTIM window, click the Cisco CallManager integration.
- Step 13** In the right pane, click the name of the cluster name you created in this procedure.
- Step 14** In the right pane, click the **Ports** tab.
- Step 15** Enter the settings shown in [Table 17](#) for the voice messaging ports.



**Caution** In programming Cisco CallManager, do not send calls to voice messaging ports in Cisco Unity that cannot answer calls (voice messaging ports that are not set to Answer Calls). For example, if a voice messaging port is set only to Dialout MWI, do not send calls to it.

**Table 17** Settings for the Voice Messaging Ports

| Field                | Considerations                                                                                                                                                                                                                                                                                                                                    |
|----------------------|---------------------------------------------------------------------------------------------------------------------------------------------------------------------------------------------------------------------------------------------------------------------------------------------------------------------------------------------------|
| Extension            | Enter the extension for the port as assigned on the phone system.                                                                                                                                                                                                                                                                                 |
| Enabled              | Check this check box to enable the port. The port is enabled during normal operation.<br>Uncheck this check box to disable the port. When the port is disabled, calls to the port get a ringing tone but are not answered. Typically, the port is disabled only by the installer during testing.                                                  |
| Answer Calls         | Check this check box to designate the port for answering calls. These calls can be incoming calls from unidentified callers or from subscribers. As a general guideline, set Answer Calls on approximately 75 percent of the ports.                                                                                                               |
| Message Notification | Check this check box to designate the port for notifying subscribers of messages. Assign Message Notification to the least busy ports, which typically are those with the highest port numbers for the phone system. As a general guideline, set Message Notification, Dialout MWI, and TRAP Connection on approximately 25 percent of the ports. |

**Table 17** Settings for the Voice Messaging Ports (continued)

| Field                                                                   | Considerations                                                                                                                                                                                                                                                                                                                                                                                                                                                                                                                                                                                                                                                                                                                                                                                    |
|-------------------------------------------------------------------------|---------------------------------------------------------------------------------------------------------------------------------------------------------------------------------------------------------------------------------------------------------------------------------------------------------------------------------------------------------------------------------------------------------------------------------------------------------------------------------------------------------------------------------------------------------------------------------------------------------------------------------------------------------------------------------------------------------------------------------------------------------------------------------------------------|
| Dialout MWI<br><i>(not used by serial or SMDI integrations)</i>         | Check this check box to designate the port for turning MWIs on and off. Assign Dialout MWI to the least busy ports, which typically are those with the highest port numbers for the phone system. As a general guideline, set Message Notification, Dialout MWI, and TRAP Connection on approximately 25 percent of the ports.                                                                                                                                                                                                                                                                                                                                                                                                                                                                    |
| AMIS Delivery<br><i>(available with the AMIS licensed feature only)</i> | <p>Check this check box to designate the port for making outbound AMIS calls to deliver voice messages from Cisco Unity subscribers to users on another voice messaging system. Cisco Unity supports the Audio Messaging Interchange Specification (AMIS) protocol, which provides an analog mechanism for transferring voice messages between different voice messaging systems.</p> <p>This setting affects outbound AMIS calls only. All ports are used for incoming AMIS calls. Because the transmission of outgoing AMIS messages may tie up voice ports for long periods of time, you may want to adjust the schedule on the Network &gt; AMIS &gt; Schedule page so that outgoing AMIS calls are placed during closed hours or at times when Cisco Unity is not processing many calls.</p> |
| TRAP Connection                                                         | Check this check box so that subscribers can use the phone as a recording and playback device in Cisco Unity web applications and e-mail clients. Assign TRAP Connection to the least busy ports, which typically are those with the highest port numbers for the phone system. As a general guideline, set Message Notification, Dialout MWI, and TRAP Connection on approximately 25 percent of the ports.                                                                                                                                                                                                                                                                                                                                                                                      |

**Step 16** In the UTIM window, click **Save**.

**Step 17** Exit UTIM.

**Step 18** Repeat [Step 1](#) through [Step 17](#) for all remaining Cisco CallManager clusters.

## Testing the Integration

To test whether Cisco Unity and the phone system are integrated correctly, do the following procedures in the order listed.

If any of the steps indicates a failure, refer to the following documentation as applicable:

- The installation guide for the phone system
- *Cisco Unity Troubleshooting Guide*, available at [http://www.cisco.com/en/US/products/sw/voicesw/ps2237/prod\\_troubleshooting\\_guides\\_list.html](http://www.cisco.com/en/US/products/sw/voicesw/ps2237/prod_troubleshooting_guides_list.html)
- The setup information earlier in this guide

### To Set Up the Test Configuration

**Step 1** Set up two test extensions (Phone 1 and Phone 2) on the same phone system that Cisco Unity is connected to.

**Step 2** Set Phone 1 to forward calls to the Cisco Unity pilot number when calls are not answered.

**Step 3** In the Cisco Unity Administrator, create a test subscriber to use for testing by doing the applicable substeps below.

If your message store is Microsoft Exchange, do the following:

- a. In the Cisco Unity Administrator, go to the **Subscribers > Subscribers > Profile** page.
- b. Click the **Add** icon.
- c. Select **New Exchange Subscriber**.
- d. Enter the applicable information on the Add Subscriber page.
- e. Click **Add**.

If your message store is IBM Lotus Domino, do the following:

- a. In the Cisco Unity Administrator, go to the **Subscribers > Subscribers > Profile** page.
- b. Click the **Add** icon.
- c. Click **Notes**.
- d. In the Address Book list, confirm that the address book listed is the one that contains the user data that you want to import.

If the address book that you want to use is not listed, go to the **System > Configuration > Subscriber Address Books** page and add a different address book.

- e. In the Find Domino Person By list, indicate whether to search by short name, first name, or last name.
- f. Enter the applicable short name or name. You also can enter \* to display a list of all users, or enter one or more characters followed by \* to narrow your search.
- g. Click **Find**.
- h. On the list of matches, click the name of the user to import.
- i. Enter the applicable information on the Add Subscriber page.
- j. Click **Add**.

**Step 4** In the Extension field, enter the extension of Phone 1.

**Step 5** In the Active Schedule field, click **All Hours - All Days**.

**Step 6** Click the **Save** icon.

**Step 7** In the navigation bar, click **Call Transfer** to go to the Subscribers > Subscribers > Call Transfer page for the test subscriber.

For more information on transfer settings, refer to the “Subscriber Template Call Transfer Settings” section in the Cisco Unity Administrator Help.

**Step 8** Under Transfer Incoming Calls, click **Yes, Ring Subscriber’s Extension**, and confirm that the extension number is for Phone 1.

**Step 9** Under Transfer Type, click **Release to Switch**.

**Step 10** Click the **Save** icon.

**Step 11** In the navigation bar, click **Messages** to go to the Subscribers > Subscribers > Messages page for the test subscriber.

**Step 12** Under Message Waiting Indicators (MWIs), check **Use MWI for Message Notification**.

**Step 13** In the Extension field, enter **x**.

**Step 14** Click the **Save** icon.

- Step 15** Open the Status Monitor by doing one of the following:
- In Internet Explorer, go to **http://<Cisco Unity server name>/web/sm**.
  - Double-click the desktop shortcut to the Status Monitor.
  - In the status bar next to the clock, right-click the Cisco Unity tray icon and click **Status Monitor**.
- 

#### To Test an External Call with Release Transfer

---

- Step 1** From Phone 2, enter the access code necessary to get an outside line, then enter the number outside callers use to dial directly to Cisco Unity.
- Step 2** On the Status Monitor, note the port that handles this call.
- Step 3** When you hear the opening greeting, enter the extension for Phone 1. Hearing the opening greeting means that the port is configured correctly.
- Step 4** Confirm that Phone 1 rings and that you hear a ringback tone on Phone 2. Hearing a ringback tone means that Cisco Unity released the call and transferred it to Phone 1.
- Step 5** Leaving Phone 1 unanswered, confirm that the state of the port handling the call changes to “Idle.” This state means that release transfer is successful.
- Step 6** Confirm that, after the number of rings that the phone system is set to wait, the call is forwarded to Cisco Unity and that you hear the greeting for the test subscriber. Hearing the greeting means that the phone system forwarded the unanswered call and the call-forward information to Cisco Unity, which correctly interpreted the information.
- Step 7** On the Status Monitor, note the port that handles this call.
- Step 8** Leave a message for the test subscriber and hang up Phone 2.
- Step 9** On the Status Monitor, confirm that the state of the port handling the call changes to “Idle.” This state means that the port was successfully released when the call ended.
- Step 10** Confirm that the MWI on Phone 1 is activated. The activated MWI means that the phone system and Cisco Unity are successfully integrated for turning on MWIs.
- 

#### To Test an Internal Call with Release Transfer

---

- Step 1** From Phone 1, enter the internal pilot number for Cisco Unity.
- Step 2** When asked for your password, enter **12345**. Hearing the request for your password means that the phone system sent the necessary call information to Cisco Unity, which correctly interpreted the information.
- Step 3** Confirm that you hear the recorded voice name for the test subscriber (if you did not record a voice name for the test subscriber, you will hear the extension number for Phone 1). Hearing the voice name means that Cisco Unity correctly identified the subscriber by the extension.
- Step 4** When asked whether you want to listen to your message, press **1**.
- Step 5** After listening to the message, press **3** to delete the message.
- Step 6** Confirm that the MWI on Phone 1 is deactivated. The deactivated MWI means that the phone system and Cisco Unity are successfully integrated for turning off MWIs.
- Step 7** Hang up Phone 1.

- Step 8** On the Status Monitor, confirm that the state of the port handling the call changes to “Idle.” This state means that the port was successfully released when the call ended.
- 

#### To Set Up Supervised Transfer on Cisco Unity

---

- Step 1** In the Cisco Unity Administrator, go to the **Subscribers > Subscribers > Call Transfer** page.  
If the name of the test subscriber is not displayed, click the **Find** icon (the magnifying glass) in the title bar, then click **Find**, and select the name of the test subscriber in the list that appears.  
For more information on transfer settings, refer to the “Subscriber Template Call Transfer Settings” section in the Cisco Unity Administrator Help.
- Step 2** Under Transfer Type, click **Supervise Transfer**.
- Step 3** Set the Rings to Wait For field to **3**.
- Step 4** Click the **Save** icon.
- 

#### To Test Supervised Transfer

---

- Step 1** From Phone 2, enter the access code necessary to get an outside line, then enter the number outside callers use to dial directly to Cisco Unity.
- Step 2** On the Status Monitor, note the port that handles this call.
- Step 3** When you hear the opening greeting, enter the extension for Phone 1. Hearing the opening greeting means that the port is configured correctly.
- Step 4** Confirm that Phone 1 rings and that you do not hear a ringback tone on Phone 2. Instead, you should hear the indication your phone system uses to mean that the call is on hold (for example, music or beeps).
- Step 5** Leaving Phone 1 unanswered, confirm that the state of the port handling the call remains “Busy.” This state and hearing an indication that you are on hold mean that Cisco Unity is supervising the transfer.
- Step 6** Confirm that, after three rings, you hear the greeting for the test subscriber. Hearing the greeting means that Cisco Unity successfully recalled the supervised-transfer call.
- Step 7** During the greeting, hang up Phone 2.
- Step 8** On the Status Monitor, confirm that the state of the port handling the call changes to “Idle.” This state means that the port was successfully released when the call ended.
- 

#### To Delete the Test Subscriber

---

- Step 1** In the Cisco Unity Administrator, go to the **Subscribers > Subscribers > Profile** page.  
If the name of the test subscriber is not displayed, click the **Find** icon (the magnifying glass) in the title bar, then click **Find**, and select the name of the test subscriber in the list that appears.
- Step 2** In the title bar, click the **Delete Subscriber** icon (the X).
- Step 3** Click **Delete**.
-

# Integrating a Secondary Server for Cisco Unity Failover

The Cisco Unity failover feature enables a secondary server to provide voice messaging services when the primary server becomes inactive. For information on installing a secondary server for failover, refer to the *Cisco Unity Installation Guide*, available at

[http://www.cisco.com/en/US/products/sw/voicesw/ps2237/prod\\_installation\\_guides\\_list.html](http://www.cisco.com/en/US/products/sw/voicesw/ps2237/prod_installation_guides_list.html).

For information on failover, refer to the *Cisco Unity Failover Configuration and Administration Guide*, available at [http://www.cisco.com/univercd/cc/td/doc/product/voice/c\\_unity/fail/fail401/ex/index.htm](http://www.cisco.com/univercd/cc/td/doc/product/voice/c_unity/fail/fail401/ex/index.htm).

## Requirements

The following components are required to integrate a secondary server:

- One secondary server for each primary server installed and ready for the integration, as described in the *Cisco Unity Installation Guide* and earlier in this integration guide.
- A license that enables failover.

## Integration Description

The phone system communicates with both the primary and secondary servers through the LAN. [Figure 4](#) shows the required connections.

**Figure 4** Connections Between Cisco CallManager and the Cisco Unity Servers

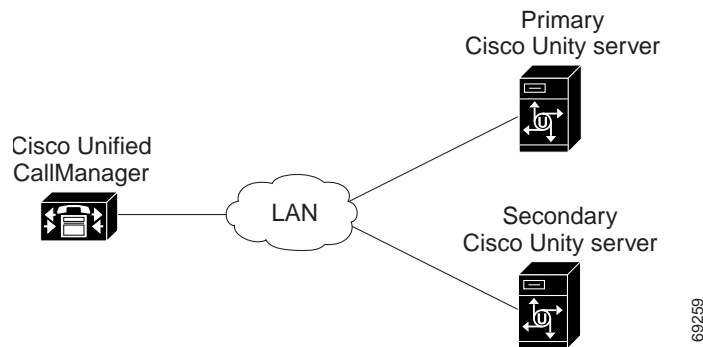

The primary and secondary servers act in the following manner:

- When the primary server is operating normally, the secondary server is inactive.
- When the primary server becomes inactive, the secondary server becomes active.
- When the primary server becomes active again, the secondary server becomes inactive.

## Setting Up the Secondary Server for Failover

Before proceeding, confirm that Cisco CallManager is configured as described in the “Programming the Cisco CallManager Phone System” section earlier in this integration guide, including the following:

- For each voice mail port, the Forward Busy and Forward No Answer fields are set to forward to the next voice mail port (the default configuration of the Cisco Voice Mail Wizard).
- The name of the voice mail server and voice mail ports that serve the secondary server are different from the name of the voice mail server and voice mail ports that serve the primary server.

Do the following two procedures to integrate the secondary server.

### To Configure Cisco CallManager

---

**Step 1** In the Cisco CallManager Administration, click **Feature > Voice Mail > Cisco Voice Mail Port**.

**Step 2** For the last voice mail port that answers calls on the primary server, set the Forward Busy field to the first voice mail port on the primary server.

If there are voice mail ports on the primary server that do not answer calls (for example, voice mail ports set only to Dialout MWI), leave the Forward Busy field blank.



---

**Caution** In programming Cisco CallManager, do not send calls to ports in Cisco Unity that cannot answer calls (ports that are not set to Answer Calls). For example, if a port is set only to Dialout MWI, do not send calls to it.

---

For a diagram of the voice mail port settings, see [Figure 5](#).

**Step 3** For all voice mail ports that answer calls on the primary server, set the Forward No Answer field to the first voice mail port on the secondary server.

If there are voice mail ports on the primary server that do not answer calls (for example, voice mail ports set only to Dialout MWI), set the Forward No Answer field to the first voice mail port on the primary server.



---

**Caution** In programming Cisco CallManager, do not send calls to ports in Cisco Unity that cannot answer calls (ports that are not set to Answer Calls). For example, if a port is set only to Dialout MWI, do not send calls to it.

---

For a diagram of the voice mail port settings, see [Figure 5](#).

**Step 4** For the last voice mail port that answers calls on the secondary server, set the Forward Busy and Forward No Answer fields to the first voice mail port on the secondary server.

If there are voice mail ports on the secondary server that do not answer calls (for example, voice mail ports set only to Dialout MWI), leave the Forward Busy field blank and set the Forward No Answer field to the first voice mail port on the secondary server.





---

**Caution** In programming Cisco CallManager, do not send calls to ports in Cisco Unity that cannot answer calls (ports that are not set to Answer Calls). For example, if a port is set only to Dialout MWI, do not send calls to it.

---

For a diagram of the voice mail port settings, see [Figure 5](#).

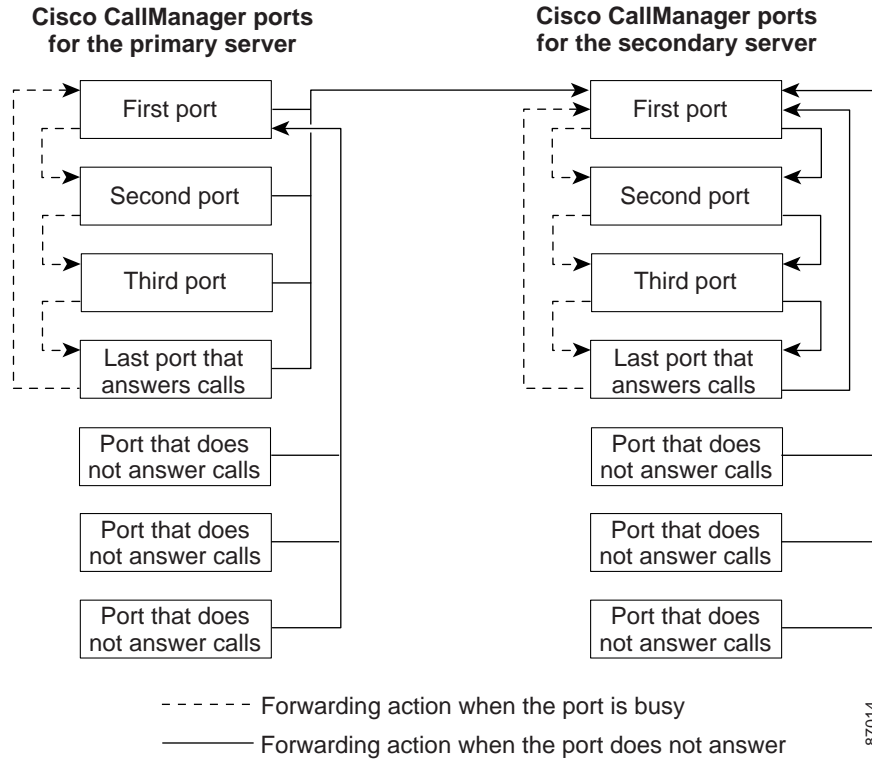
**Figure 5 Cisco CallManager Voice Mail Port Configuration for Cisco Unity Failover**



**To Set Up the Secondary Server for Failover**

- Step 1** Install a secondary server with the same configuration as the primary server. For installation instructions, refer to the *Cisco Unity Installation Guide*.
- Step 2** On the Windows Start menu of the secondary server, click **Programs > Cisco Unity > Manage Integrations**. The UTIM window appears.
- Step 3** On the Integration menu of the UTIM window, click **New**. The Telephony Integration Setup Wizard appears.
- Step 4** Enter the settings to match the integration settings on the primary server.
- Step 5** At the prompt to restart the Cisco Unity server, click **Yes**. The Cisco Unity server restarts.

**Note** When restarting Cisco Unity, use the UTIM prompt instead of the Cisco Unity icon in the Windows taskbar. The taskbar icon does not restart all of the Cisco Unity services.

- Step 6** After Cisco Unity restarts, on the Windows Start menu of the Cisco Unity server, click **Programs > Cisco Unity > Manage Integrations**. UTIM appears.
- Step 7** In the left pane of the UTIM window, click the phone system integration you created in [Step 4](#).

- Step 8 In the right pane of the UTIM window, click the **Ports** tab.
  - Step 9 Enter the port settings to match the port settings on the primary server.
  - Step 10 Click **Save**.
  - Step 11 Exit UTIM.
- 

## Changing the Settings for an Existing Integration

After the integration is set up, if you want to change any of its settings (for example, to change the MWI settings), do the following procedure.

If you want to change the number of voice messaging ports, see the [“Changing the Number of Voice Messaging Ports”](#) section on page 30.

### To Change the Settings for an Integration

- 
- Step 1 On the Cisco Unity server, on the Windows Start menu, click **Programs > Cisco Unity > Manage Integrations**. The UTIM window appears.
  - Step 2 In the left pane, double-click **Unity Server**. The existing integrations appear.
  - Step 3 Click the integration you want to modify.
  - Step 4 In the right pane, click the cluster for the integration.
  - Step 5 In the right pane, click the applicable tab for the integration.
  - Step 6 Enter new settings in the fields that you want to change.



**Caution** If you are adding or removing voice messaging ports, make sure you change the settings for the individual ports so that there are an appropriate number of ports set to answer calls and an appropriate number of ports set to dial out.

---

- Step 7 In the UTIM window, click **Save**.
  - Step 8 If prompted, restart the Cisco Unity services.
- 

## Changing the Number of Voice Messaging Ports

To change the number of voice messaging ports after you have finished installing and setting up Cisco CallManager, do the following procedures.

### To Change the Number of Voice Messaging Ports in the Cisco CallManager Administration

- 
- Step 1 On the Cisco CallManager server, use the Cisco Voice Mail Port Wizard to add or remove voice messaging ports, as applicable.

For information on adding voice messaging ports, see the [“To Add Voice Mail Ports to Cisco CallManager” section on page 10](#). For information on removing voice mail ports, refer to the Cisco CallManager Administrator Help.

- Step 2** Continue with the next procedure.

---

### To Update Cisco Unity for Additional Voice Messaging Ports

---

- Step 1** If the Cisco Unity license does not enable the additional voice messaging ports you added, see your sales representative to request the applicable license.
- Step 2** When you have the license, on the Cisco Unity server, click **Programs > Cisco Unity > Licensing**.
- Step 3** On the Action menu, click **Install License Files**.
- Step 4** Follow the on-screen instructions.



**Note** If you increase the number of voice messaging ports from 32 or fewer to more than 32, you must also install SQL Server 2000 as described in the *Cisco Unity Installation Guide*.

- Step 5** Continue with the [“Changing the Settings for an Existing Integration” section on page 30](#).
- 

## Deleting an Existing Integration

If you want to delete an existing integration (for example, you have replaced the phone system with which Cisco Unity originally integrated), do the following procedure.

### To Delete an Existing Integration

---

- Step 1** On the Cisco Unity server, on the Windows Start menu, click **Programs > Cisco Unity > Manage Integrations**. The UTIM window appears.
- Step 2** In the left pane, double-click **Unity Server**. The existing integrations appear.
- Step 3** Click the integration that you want to delete.
- Step 4** On the Integration menu, click **Delete**.
- Step 5** Follow the on-screen instructions to assign the subscribers of the deleted phone system integration to another phone system integration.
- Step 6** At the prompt to restart the Cisco Unity services, click **Yes**. The Cisco Unity services restart.



**Note** When restarting Cisco Unity, use the UTIM prompt instead of the Cisco Unity icon in the Windows taskbar. The taskbar icon does not restart all of the Cisco Unity services.

- Step 7** If the integration you deleted used voice cards, remove the voice cards from the Cisco Unity server.
-

# Troubleshooting the Cisco CallManager Integration

This section provides information about common integration problems.

## Cisco Unity Does Not Answer When the Extension for Cisco Unity Is Dialed

If you hear a fast busy or number unobtainable signal when you dial Cisco Unity, do the following procedure.

### To Confirm That the Phone System Programming Is Complete

---

- Step 1** Review the phone system programming to confirm that it is complete. Specific actions to take are:
- Confirming that the voice mail ports are correctly set up. For details, see the [“To Add Voice Mail Ports to Cisco CallManager”](#) section on page 10.
  - Confirming that the voice mail ports and phones are in the same calling search space. For details, see the [“To Add Voice Mail Ports to Cisco CallManager”](#) section on page 10.
- Step 2** Exit the Cisco Unity software, then restart the server.
- 

## Appendix: Using Alternate Extensions and MWIs

---

### Alternate Extensions

In addition to the “primary” extension that you specify for subscribers, you can assign subscribers up to nine alternate extensions. (The primary extension is the one that you assign to each subscriber when you create his or her subscriber account; it is listed on the Subscribers > Subscribers > Profile page.)

#### Reasons to Use Alternate Extensions

There are several reasons why you may want to specify alternate extensions for subscribers. For example, if you have more than one Cisco Unity server that accesses a single, corporate-wide directory, you may want to use alternate extensions so that a subscriber uses the same number when addressing a message to a subscriber associated with another Cisco Unity server and when calling that subscriber directly. You may also want to use alternate extensions to:

- Handle multiple line appearances on subscriber phones.
- Offer easy message access on direct calls from a cell phone, home phone, or phone at an alternate work site (assuming that the phone number is passed along to Cisco Unity from these other phone systems). In addition, when such phones are used as alternate extensions, and are set to forward to Cisco Unity, callers can listen to the subscriber greeting, and leave messages for the subscriber just as they would when dialing the primary extension for the subscriber.

**Tip**

To reduce the number of requests from subscribers who want alternate extensions set up for multiple cell phones, home phones, and other phones, give subscribers class of service (COS) rights to specify their own set of alternate extensions. (See the [Subscribers > Class of Service > Profile](#) page.) With proper COS rights, a subscriber can specify up to five alternate extensions in the Cisco Unity Assistant—in addition to the nine that you can specify on the [Subscribers > Alternate Extensions](#) page in the Cisco Unity Administrator.

- Simplify addressing messages to subscribers at different locations. With alternate extensions, the number that a subscriber uses when addressing a message to someone at another location can be the same number that the subscriber dials when calling.
- Enable URL-based extensions in Cisco Unity for an integration with a SIP phone system.

**How Alternate Extensions Work**

Before you set up alternate extensions, review the following list for information on how alternate extensions work:

- Alternate extensions cannot exceed 30 characters in length. By default, each administrator-defined alternate extension must be at least 3 characters in length, while subscriber-defined alternate extensions must be at least 10 characters.

You can use the Advanced Settings tool in Tools Depot to specify a minimum extension length for the extensions entered in the Cisco Unity Administrator and the Cisco Unity Assistant. Refer to the Advanced Settings Tool Help for details on using the settings. Respectively, the settings are Administration—Set the Minimum Length for Locations and Administration—Set the Minimum Length for Subscriber-Defined Alternate Extensions.

- You can control whether subscribers can use the Cisco Unity Assistant to view the alternate extensions that you specify in the Cisco Unity Administrator. To do so, see the [Subscribers > Class of Service > Profile](#) page. The Subscriber-Defined Alternate Extension table displays the alternate extensions that the subscriber adds.
- Neither the Cisco Unity Administrator nor the Cisco Unity Assistant will accept an extension that is already assigned to another subscriber (either as a primary or alternate extension), or to a public distribution list, call handler, directory handler, or interview handler. Cisco Unity verifies that each alternate extension is unique—up to the dialing domain level, if applicable—before allowing either an administrator or a subscriber to create it.
- All alternate extensions utilize the same transfer settings as the primary extension.
- In many cases, Cisco Unity can activate a message waiting indicator (MWI) for an alternate extension, though depending on the phones and phone systems involved, some additional phone system programming may be required to set this up.

## Setting Up Alternate Extensions

Do the applicable procedure to add, modify, or delete alternate extensions:

- [To Add Administrator-Defined Alternate Extensions, page 34](#)
- [To Modify or Delete Alternate Extension\(s\), page 34](#)

### To Add Administrator-Defined Alternate Extensions

- 
- Step 1** In the Cisco Unity Administrator, go to any **Subscribers > Alternate Extensions** page.
- Step 2** In the Administrator-Defined Alternate Extensions table, enter an extension in any row. When entering characters in the Alternate Extensions table, consider the following:
- You can enter an extension up to 30 characters in length. (SIP integrations can use up to 30 alphanumeric characters.)
  - Each extension must be unique—up to the dialing domain level, if applicable.
  - Enter digits 0 through 9. Do not use spaces, dashes, or parentheses.
  - For SIP integrations, you can also enter a valid alias for a SIP URL. For example, if the URL is SIP:aabade@cisco.com, enter aabade. Do not use spaces.
  - Rows are numbered as a convenience. You can enter alternate extensions in any order, and you can have blank rows.
- Step 3** Repeat [Step 2](#) as necessary.
- Step 4** Click the **Save** icon. Alternate extensions are enabled for all rows in the table.
- 



#### Note

You can run the Cisco Unity Bulk Import wizard when you want to add alternate extensions for multiple subscribers at once. When you do, the Cisco Unity Bulk Import wizard appends the existing table of alternate extensions, beginning with the first blank row.

---

### To Modify or Delete Alternate Extension(s)

- 
- Step 1** In the Cisco Unity Administrator, go to any **Subscribers > Alternate Extensions** page.
- Step 2** Do any of the following:
- To modify an extension, change the extension in the Alternate Extensions table.
  - To delete extensions, check the check boxes next to the alternate extensions that you want to delete.
  - To remove all alternate extensions listed in the table, click **Select All**.
- Step 3** Click the **Save** icon.
- Step 4** Repeat [Step 2](#) and [Step 3](#) as necessary.
- 

## Alternate MWIs

You can set up Cisco Unity to activate alternate MWIs when you want a new message for a subscriber to activate the MWIs at up to 10 extensions. For example, a message left at extension 1001 can activate the MWIs on extensions 1001 and 1002.

Cisco Unity uses MWIs to alert the subscriber to new voice messages. MWIs are not used to indicate new e-mail, fax, or return receipt messages.

In Cisco CallManager integrations, you can also use the alternate MWI feature to activate MWIs on a non-integrated phone system that can send and receive information from Cisco Unity over an RS-232 serial cable.

This section contains the following information:

- [Setting Up Alternate MWIs for Extensions on the Same Phone System, page 35](#)
- [MWIs for Extensions on a Non-Integrated Phone System, page 36](#)
- [Setting Up MWIs for Extensions on a Non-Integrated Phone System, page 37](#)

## Setting Up Alternate MWIs for Extensions on the Same Phone System

Cisco Unity can activate alternate MWIs for extensions on the same phone system. Note that depending on the phones and phone systems, some additional phone system programming may be necessary. Refer to the installation guide for the phone system.

To enable alternate MWIs for extensions on the same phone system, do the following procedure for each subscriber who needs alternate MWIs.

### To Set Up Alternate MWIs for Extensions on the Same Phone System

- 
- Step 1** In the Cisco Unity Administrator, go to the applicable **Subscribers > Subscribers > Messages** page.
  - Step 2** Confirm that the **Use MWI for Message Notification** check box is checked.
  - Step 3** Click the **Add** button located beneath the MWI Extensions table to add a row to the table. By default, the first row in the table contains an “X” to indicate the primary extension assigned to a subscriber. If you want one more extension and do not need to activate the MWI on the primary extension, you can also modify the first row.
  - Step 4** Enter the applicable extension in the **Extension** field of the table. MWIs are automatically enabled for all rows in the table. When entering characters in the MWI Extensions table, consider the following:
    - Enter digits 0 through 9. Do not use spaces, dashes, or parentheses.
    - Enter , (comma) to insert a one-second pause.
    - Enter # and \* to correspond to the # and \* keys on the phone.
  - Step 5** Click the **Save** icon.
  - Step 6** Repeat [Step 3](#) through [Step 5](#) as necessary.
- 



#### Note

You can run the Cisco Unity Bulk Import wizard when you want to set up alternate MWIs for multiple subscribers at once.

To change or delete alternate MWIs for extensions, do the following procedure.

### To Modify or Delete Alternate MWIs

- 
- Step 1** In the Cisco Unity Administrator, go to the applicable **Subscribers > Subscribers > Messages** page.
  - Step 2** Do either of the following:

- To modify an extension, change the extension in the MWI Extensions table.
- To delete extensions, check the check boxes next to the rows that you want to delete in the MWI Extensions table, and then click the **Delete** button.

**Step 3** Click the **Save** icon.

**Step 4** Repeat [Step 2](#) and [Step 3](#) as necessary.

## MWIs for Extensions on a Non-Integrated Phone System

Cisco Unity can activate MWIs on a phone system that is not integrated with Cisco Unity and that is not part of a dual phone system integration (referred to here as a non-integrated phone system). MWI activation requests are sent through an RS-232 serial cable.

For this method, you must set up:

- A trunk connection between Cisco CallManager and the non-integrated phone system through a gateway.
- The unique subscriber extensions on the non-integrated phone system to forward on no answer to the corresponding phantom extensions on Cisco CallManager.
- The Switch.ini file (phone system configuration file) to enable Cisco Unity access through the serial cable for turning alternate MWIs on and off.
- An RS-232 serial cable between a Cisco Unity serial port and the non-integrated phone system serial port to send alternate MWI activation requests.
- The Cisco Unity serial configuration file, if the non-integrated phone system uses a serial configuration different from the default serial configuration used by Cisco Unity.

[Figure 6](#) shows the connections via a serial cable between a Cisco CallManager integration and a non-integrated phone system.

**Figure 6** Connection for Sending Alternate MWIs via a Serial Cable to a Non-Integrated Phone System from a Cisco CallManager Integration

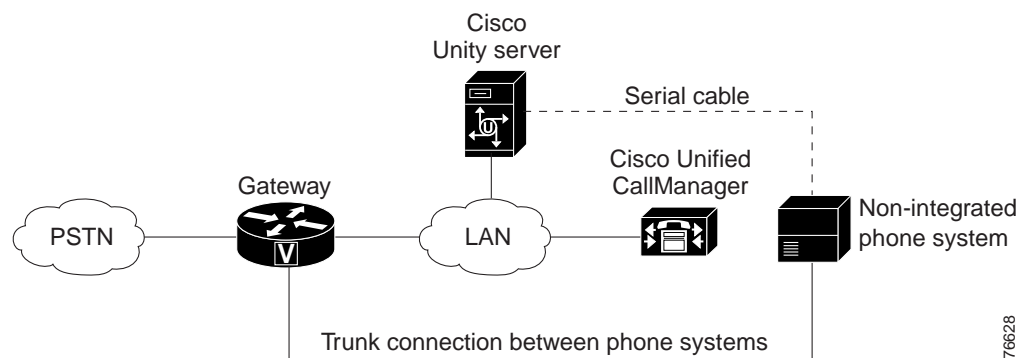

Calls to subscribers that come from the non-integrated phone system are routed through the gateway to Cisco CallManager.

## Setting Up MWIs for Extensions on a Non-Integrated Phone System

To set up MWIs for extensions on a non-integrated phone system, do the following applicable procedures.

### To Set Up MWIs on a Non-Integrated Phone System

- 
- Step 1** Set up a trunk connection between the non-integrated phone system and Cisco CallManager through the gateway.
- Step 2** In the Cisco Unity Administrator, set up the subscriber for the phantom extension, making use of the subscriber information from the corresponding extension on the non-integrated phone system, including the following settings:
- On the Subscriber > Profile page for the subscriber, in the Extension field, enter the corresponding extension on the non-integrated phone system.
  - On the Subscriber > Call Transfer page for the subscriber, under Transfer Incoming Calls, click **No**.
  - On the Subscriber > Messages page for the subscriber, confirm that the **Use MWI for Message Notification** check box is checked.
  - On the Subscriber > Messages page for the subscriber, under MWI Extensions, delete the “X” and enter **ZX**.
- Step 3** In the Cisco Unity Administrator, click the **Save** icon.
- 

### To Revise the Switch.ini File

- 
- Step 1** On the Windows Start menu, click **Programs > Cisco Unity > Manage Integrations**. UTIM appears.
- Step 2** In the left pane of the UTIM window, click the Cisco CallManager integration, and click the **Properties** node. The Properties tab appears in the right pane of the UTIM window.
- Step 3** Note the name of the Switch.ini file that appears in the Configuration File field.
- Step 4** Exit UTIM.
- Step 5** On the Windows Start menu, click **Programs > Accessories > Notepad**. The Notepad window appears.
- Step 6** On the File menu, click **Open**.
- Step 7** In the Open window, navigate to the CommServer\IntLib directory, and double-click the name of the Switch.ini file you noted in [Step 3](#).
- Step 8** Add a new section at the end of the file to contain the following lines. For detailed information about the settings, see [Table 18](#).

```
[Alternate MWI]
Active=Yes
Digit=Z
MWIType=Serial
SerialConfiguration=<if applicable, the type of serial configuration for the connection>
```

**Table 18** *Alternate MWI Settings in the Switch.ini File*

| Line                | Setting                                                                                                                                                                                                                                                                                                                                                              |
|---------------------|----------------------------------------------------------------------------------------------------------------------------------------------------------------------------------------------------------------------------------------------------------------------------------------------------------------------------------------------------------------------|
| Active              | Enter <b>Yes</b> to enable alternate MWIs or <b>No</b> to disable alternate MWIs.                                                                                                                                                                                                                                                                                    |
| Digit               | Enter <b>Z</b> to represent the LampOn and LampOff digits in the MWI Extensions field on the Subscriber > Subscriber > Messages page.                                                                                                                                                                                                                                |
| MWIType             | Enter <b>Serial</b> .                                                                                                                                                                                                                                                                                                                                                |
| SerialConfiguration | If the MWIType field is Serial, enter the type of serial configuration: <ul style="list-style-type: none"> <li>• <b>SMDI</b> (for most serial connections)</li> <li>• <b>MCI</b> (only for NEC NEAX phone systems)</li> <li>• <b>Inte</b> (only for Intecom E14 Millennium phone systems)</li> <li>• <b>Eric</b> (only for Ericsson MD-110 phone systems)</li> </ul> |

**Step 9** Save the file, and exit Notepad.

---

Do the following procedure if the serial configuration used by the non-integrated phone system is different from the default serial configuration that Cisco Unity uses.

#### To Revise the Cisco Unity Serial Configuration File

---

**Step 1** On the Windows Start menu, click **Programs > Accessories > Notepad**. The Notepad window appears.

**Step 2** On the File menu, click **Open**.

**Step 3** In the Open window, navigate to the CommServer\IntLib directory, and double-click the file corresponding to the serial configuration you are using to activate alternate MWIs:

- Avsmdi.avd
- Avmci.avd
- Avinte.avd
- Averic.avd

**Step 4** Under the [Configuration] divider, revise the settings to match the configuration required by the non-integrated phone system. Refer to the phone system and its documentation for this information.

**Step 5** Save the file, and exit Notepad.

---

# Appendix: Documentation and Technical Assistance

## Conventions

The *Cisco CallManager 3.2 Integration Guide for Cisco Unity 4.0* uses the following conventions.

**Table 19** *Cisco CallManager 3.2 Integration Guide for Cisco Unity 4.0 Conventions*

| Convention                 | Description                                                                                                                                                                                                                                                                                                                                                                             |
|----------------------------|-----------------------------------------------------------------------------------------------------------------------------------------------------------------------------------------------------------------------------------------------------------------------------------------------------------------------------------------------------------------------------------------|
| boldfaced text             | Boldfaced text is used for: <ul style="list-style-type: none"> <li>Key and button names. (Example: Click <b>OK</b>.)</li> <li>Information that you enter. (Example: Enter <b>Administrator</b> in the User Name box.)</li> </ul>                                                                                                                                                        |
| < ><br>(angle brackets)    | Angle brackets are used around parameters for which you supply a value. (Example: In the Command Prompt window, enter <b>ping &lt;IP address&gt;</b> .)                                                                                                                                                                                                                                 |
| -<br>(hyphen)              | Hyphens separate keys that must be pressed simultaneously. (Example: Press <b>Ctrl-Alt-Delete</b> .)                                                                                                                                                                                                                                                                                    |
| ><br>(right angle bracket) | A right angle bracket is used to separate selections that you make: <ul style="list-style-type: none"> <li>On menus. (Example: On the Windows Start menu, click <b>Settings &gt; Control Panel &gt; Phone and Modem Options</b>.)</li> <li>In the navigation bar of the Cisco Unity Administrator. (Example: Go to the <b>System &gt; Configuration &gt; Settings</b> page.)</li> </ul> |
| [x]<br>(square brackets)   | Square brackets enclose an optional element (keyword or argument). (Example: [reg-e164])                                                                                                                                                                                                                                                                                                |
| [x   y]<br>(vertical line) | Square brackets enclosing keywords or arguments separated by a vertical line indicate an optional choice. (Example: [transport tcp   transport udp])                                                                                                                                                                                                                                    |

The *Cisco CallManager 3.2 Integration Guide for Cisco Unity 4.0* also uses the following conventions:



### Note

Means *reader take note*. Notes contain helpful suggestions or references to material not covered in the document.



### Caution

Means *reader be careful*. In this situation, you might do something that could result in equipment damage or loss of data.

# Cisco Unity Documentation

For descriptions and URLs of Cisco Unity documentation on Cisco.com, refer to *About Cisco Unity Documentation*. The document is shipped with Cisco Unity and is available at [http://www.cisco.com/univercd/cc/td/doc/product/voice/c\\_unity/about/aboutdoc.htm](http://www.cisco.com/univercd/cc/td/doc/product/voice/c_unity/about/aboutdoc.htm).

## Obtaining Documentation

Cisco documentation and additional literature are available on Cisco.com. Cisco also provides several ways to obtain technical assistance and other technical resources. These sections explain how to obtain technical information from Cisco Systems.

### Cisco.com

You can access the most current Cisco documentation on the World Wide Web at this URL:

<http://www.cisco.com/univercd/home/home.htm>

You can access the Cisco website at this URL:

<http://www.cisco.com>

International Cisco websites can be accessed from this URL:

[http://www.cisco.com/public/countries\\_languages.shtml](http://www.cisco.com/public/countries_languages.shtml)

## Ordering Documentation

You can find instructions for ordering documentation at this URL:

[http://www.cisco.com/univercd/cc/td/doc/es\\_inpk/pdi.htm](http://www.cisco.com/univercd/cc/td/doc/es_inpk/pdi.htm)

You can order Cisco documentation in these ways:

- Registered Cisco.com users (Cisco direct customers) can order Cisco product documentation from the Ordering tool:  
<http://www.cisco.com/en/US/partner/ordering/index.shtml>
- Nonregistered Cisco.com users can order documentation through a local account representative by calling Cisco Systems Corporate Headquarters (California, USA) at 408 526-7208 or, elsewhere in North America, by calling 800 553-NETS (6387).

## Documentation Feedback

You can submit e-mail comments about technical documentation to [bug-doc@cisco.com](mailto:bug-doc@cisco.com).

You can submit comments by using the response card (if present) behind the front cover of your document or by writing to the following address:

Cisco Systems  
Attn: Customer Document Ordering  
170 West Tasman Drive  
San Jose, CA 95134-9883

We appreciate your comments.

## Obtaining Technical Assistance

For all customers, partners, resellers, and distributors who hold valid Cisco service contracts, the Cisco Technical Assistance Center (TAC) provides 24-hour-a-day, award-winning technical support services, online and over the phone. Cisco.com features the Cisco Technical Support website as an online starting point for technical assistance. If you do not hold a valid Cisco service contract, please contact your reseller.

### Cisco Technical Support Website

The Cisco Technical Support website provides online documents and tools for troubleshooting and resolving technical issues with Cisco products and technologies. The Cisco Technical Support website is available 24 hours a day, 365 days a year. The Cisco Technical Support website is located at this URL:

<http://www.cisco.com/tac>

Accessing all the tools on the Cisco Technical Support website requires a Cisco.com user ID and password. If you have a valid service contract but do not have a login ID or password, register at this URL:

<http://tools.cisco.com/RPF/register/register.do>

### Opening a TAC Case

Using the online TAC Case Open Tool is the fastest way to open P3 and P4 cases. (P3 and P4 cases are those in which your network is minimally impaired or for which you require product information.) After you describe your situation, the TAC Case Open Tool automatically recommends resources for an immediate solution. If your issue is not resolved using the recommended resources, your case will be assigned to a Cisco TAC engineer. The online TAC Case Open Tool is located at this URL:

<http://www.cisco.com/tac/caseopen>

For P1 or P2 cases (P1 and P2 cases are those in which your production network is down or severely degraded) or if you do not have Internet access, contact Cisco TAC by telephone. Cisco TAC engineers are assigned immediately to P1 and P2 cases to help keep your business operations running smoothly.

To open a case by telephone, use one of the following numbers:

Asia-Pacific: +61 2 8446 7411 (Australia: 1 800 805 227)

EMEA: +32 2 704 55 55

USA: 1 800 553-2447

For a complete listing of Cisco TAC contacts, go to this URL:

<http://www.cisco.com/warp/public/687/Directory/DirTAC.shtml>

## TAC Case Priority Definitions

To ensure that all cases are reported in a standard format, Cisco has established case priority definitions.

Priority 1 (P1)—Your network is “down” or there is a critical impact to your business operations. You and Cisco will commit all necessary resources around the clock to resolve the situation.

Priority 2 (P2)—Operation of an existing network is severely degraded, or significant aspects of your business operation are negatively affected by inadequate performance of Cisco products. You and Cisco will commit full-time resources during normal business hours to resolve the situation.

Priority 3 (P3)—Operational performance of your network is impaired, but most business operations remain functional. You and Cisco will commit resources during normal business hours to restore service to satisfactory levels.

Priority 4 (P4)—You require information or assistance with Cisco product capabilities, installation, or configuration. There is little or no effect on your business operations.

## Obtaining Additional Publications and Information

Information about Cisco products, technologies, and network solutions is available from various online and printed sources.

- Cisco Marketplace provides a variety of Cisco books, reference guides, and logo merchandise. Go to this URL to visit the company store:  
<http://www.cisco.com/go/marketplace/>
- The *Cisco Product Catalog* describes the networking products offered by Cisco Systems, as well as ordering and customer support services. Access the Cisco Product Catalog at this URL:  
<http://cisco.com/univercd/cc/td/doc/pcat/>
- *Cisco Press* publishes a wide range of general networking, training and certification titles. Both new and experienced users will benefit from these publications. For current Cisco Press titles and other information, go to Cisco Press online at this URL:  
<http://www.ciscopress.com>
- *Packet* magazine is the Cisco quarterly publication that provides the latest networking trends, technology breakthroughs, and Cisco products and solutions to help industry professionals get the most from their networking investment. Included are networking deployment and troubleshooting tips, configuration examples, customer case studies, tutorials and training, certification information, and links to numerous in-depth online resources. You can access Packet magazine at this URL:  
<http://www.cisco.com/packet>
- *iQ Magazine* is the Cisco bimonthly publication that delivers the latest information about Internet business strategies for executives. You can access iQ Magazine at this URL:  
<http://www.cisco.com/go/iqmagazine>
- *Internet Protocol Journal* is a quarterly journal published by Cisco Systems for engineering professionals involved in designing, developing, and operating public and private internets and intranets. You can access the Internet Protocol Journal at this URL:  
<http://www.cisco.com/ipj>

- Training—Cisco offers world-class networking training. Current offerings in network training are listed at this URL:

<http://www.cisco.com/en/US/learning/index.html>



Copyright © 2004 Cisco Systems, Inc. All rights reserved.

