



# Installing Cisco Unified IP Phone 7960G and 7940G Hardware on the Desktop or Wall

This chapter explains how to install the Cisco Unified IP Phone 7960G and 7940G on the desktop or how to mount it to the wall. It provides information on the following:

- [Placing the Phone on the Desktop, page 2-1](#)
- [Installing the Phone on the Wall, page 2-1](#)
- [Cabling the Phone Ports, page 2-2](#)
- [Using the Phone with a Cisco Catalyst Switch, page 2-3](#)
- [Connecting the Phone to Power, page 2-4](#)
- [Where to Go Next, page 2-6](#)

## Placing the Phone on the Desktop

You can place the phone on the desktop or on the wall. The Cisco IP phone includes an adjustable footstand. When placing the phone on a desktop surface, you can adjust the tilt height to several different angles in 7.5-degree increments from flat to 60 degrees.

## Installing the Phone on the Wall

Mount the Cisco Unified IP Phone 7960G and 7940G on the wall by using the footstand as a mounting bracket or by using the optional locking bracket. To use the optional locking bracket, refer to the [Installing the Wall Mount Kit for the Cisco IP Phone](#) document on Cisco.com.



### Note

Mounting the Cisco IP Phone 7960G/7940G on the wall requires some tools and equipment that are not provided. The tools and parts required for a typical Cisco IP Phone installation are a screwdriver and screws to secure the phone to the wall.

### Procedure

- Step 1** Push in the footstand adjustment knob.
- Step 2** Adjust the footstand so that it is flat against the back of the phone, as shown in [Figure 2-1](#).

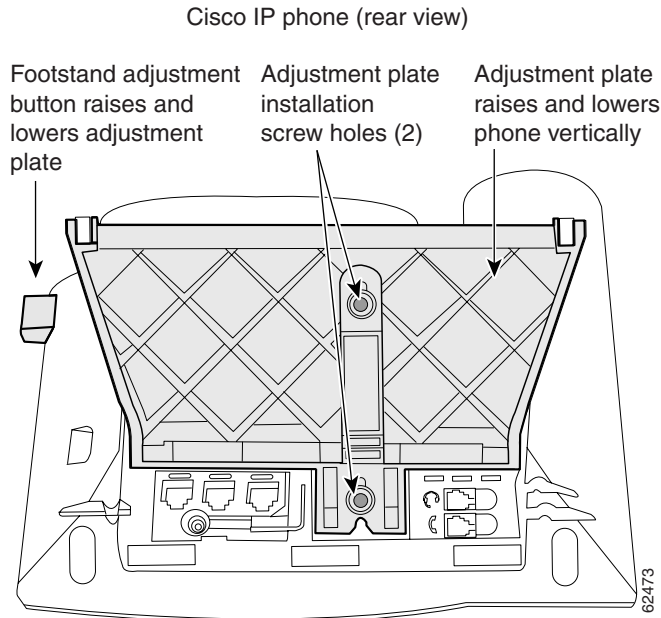
**Figure 2-1 Adjusting the Footstand**

- Step 3** Modify the handset rest so that the handset remains on the earpiece rest when the phone is vertical.
- a. Remove the handset from the earpiece rest.
  - b. Locate the tab (handset wall hook) at the base of the earpiece rest.
  - c. Slide this tab out, rotate it 180 degrees, and reinsert it.
  - d. Place the handset on the earpiece rest.
- Step 4** Insert two screws into a wall stud, matching them to the two screw holes on the back of the footstand. The screw holes fit standard phone jack mounts.
- Step 5** Hang the phone on the wall.

## Cabling the Phone Ports

The Cisco IP phone has several ports on the back of the phone, shown in [Figure 1-3 on page 1-5](#). Plug the appropriate equipment into the appropriate port.



### Caution

Consider use of an uninterruptible power supply (UPS). Without one, when you use either a local transformer or inline power on the LAN, the phone is inoperable during a power outage. This affects your ability to make emergency calls: 911 in USA and Canada, 999 in the UK, and 112 in mainland Europe.



### Note

Use of a headset does not require an amplifier. However, it does require a coil cord to connect the headset to the headset port. For information on ordering compatible headsets and coil cords, refer to <http://cisco.plantronics.com> or <http://www.vxicorp.com/cisco>.

**Note**

Do not connect the phone to power or the network at this time. Doing so causes the phone to initialize and download firmware and configuration files. Initialization and modification of the configuration files are described in the [Chapter 3, “Initializing Cisco Unified IP Phones.”](#)

## Using the Phone with a Cisco Catalyst Switch

To function in the SIP telephony network, the Cisco Unified IP Phone 7960G and 7940G must be connected to a networking device, such as a Cisco Catalyst switch, to obtain network connectivity. The Cisco IP Phone 7960G/7940G has an internal Ethernet switch, which enables it to switch traffic that comes from the phone, access port, and network port.

If a computer is connected to the access port, packets that travel to and from the computer and to and from the phone share the same physical link to the switch and the same port on the switch. This configuration has the following implications for the VLAN configuration on the network:

- The current VLANs might be configured on an IP subnet basis, and additional IP addresses might not be available to assign the phone to the same subnet as other devices (PC) connected to the same port.
- Data traffic that is present on the VLAN that supports phones might reduce the quality of VoIP traffic.

You can resolve these issues by isolating the voice traffic onto a separate VLAN on each of the ports connected to a phone. The switch port configured for connecting a phone would have separate VLANs configured for carrying the following traffic:

- Voice traffic to and from the Cisco Unified IP Phone 7960G and 7940G (auxiliary VLAN).
- Data traffic to and from the PC connected to the switch through the access port of the Cisco IP Phone 7960G/7940G (native VLAN).

Isolating the phones on a separate, auxiliary VLAN increases the quality of the voice traffic and allows a large number of phones to be added to an existing network where there are not enough IP addresses.

For redundancy, you can use the AC adapter even if you are using inline power from the Cisco Catalyst switches. The Cisco Unified IP Phone 7960G and 7940G can share the power load being used from the inline power and external power source. If either the inline power or the external power goes down, the phone can switch entirely to the other power source.

To use this redundancy feature you *must* set the inline power mode to “auto” on the Cisco Catalyst switch. Next, connect the Cisco Unified IP Phone 7960G and 7940G phone to the network without connecting it to an external power source. After the phone powers up, connect the external power supply to the phone.

For more information, refer to the documentation included with the Cisco Catalyst switch.

# Connecting the Phone to Power

Read this entire section before connecting the phone to power.



## Warning

**Read the installation instructions before you connect the system to its power source.**

**Waarschuwing** Raadpleeg de installatie-aanwijzingen voordat u het systeem met de voeding verbindt.

**Varoitus** Lue asennusohjeet ennen järjestelmän yhdistämistä virtalähteeseen.

**Attention** Avant de brancher le système sur la source d'alimentation, consulter les directives d'installation.

**Warnung** Lesen Sie die Installationsanweisungen, bevor Sie das System an die Stromquelle anschließen.

**Avvertenza** Consultare le istruzioni di installazione prima di collegare il sistema all'alimentatore.

**Advarsel** Les installasjonsinstruksjonene før systemet kobles til strømkilden.

**Aviso** Leia as instruções de instalação antes de ligar o sistema à sua fonte de energia.

**¡Advertencia!** Ver las instrucciones de instalación antes de conectar el sistema a la red de alimentación.

**Warning!** Läs installationsanvisningarna innan du kopplar systemet till dess strömförsörjningsenhet.



## Caution

When you connect the phone to power, the phone automatically begins startup and initialization. Use this section to determine how you will power your phones. Do not connect the phones to power, though, until you address the prerequisites and follow the configuration instructions in [Chapter 3, “Initializing Cisco Unified IP Phones.”](#)

You can connect the Cisco IP phone to the following power sources:

- External power source—Optional AC adapter and power cord for connecting to a standard wall receptacle.
- WS-X6348-RJ45V 10/100 switching module—Provides inline power to the phone when connected to a Cisco Catalyst 3500, 4000, or 6000 family 10/100BASE-TX switching module. This module sends power on pins 1 and 2, and 3 and 6.
- WS-PWR-PANEL—Power patch panel provides power to the phone, which allows the phone to be connected to existing Cisco Catalyst 4000, 5000, and 6000 family 10/100BASE-TX switching modules. This module sends power on pins 4, 5, 7, and 8.
- WS-X4148-RJ45V—48-port 10/100 Ethernet with inline power module for the Cisco Catalyst 4006 switch.
- WS-X4095-PEM—VoIP DC Power Entry module for the Cisco Catalyst 4006 switch.
- WS-X4608-2PSU and WS-X4608—External –48VDC power shelf common equipment for the Cisco Catalyst 4006 with two AC-to-DC power supply units (PSUs) and one empty bay for redundant option, and the 110-V 15-A AC-to-48VDC PSU redundant option for the power shelf.
- WS-C3524-PWR-XL-EN—Cisco Catalyst 3524-PWR XL switch.



## Note

- Only the network port (labeled 10/100 SW) supports inline power from the Cisco Catalyst switches.

- If you are using a Cisco Catalyst switch to provide power, see the [“Using the Phone with a Cisco Catalyst Switch”](#) section on page 2-3.
-

## Where to Go Next

Use the following information to determine where to go next in this guide:

- See [Chapter 3, “Initializing Cisco Unified IP Phones,”](#) for information on installing firmware, customizing configuration files, and connecting the phone to power sources and the network.
- See [Chapter 4, “Managing Cisco SIP IP Phones,”](#) for information on upgrading firmware and performing other management tasks.
- See [Chapter 5, “Monitoring Cisco SIP IP Phones,”](#) for information on debugging and on viewing network statistics.