



Cisco MGCP IP Phone Administrator Guide

Release 6.0, 6.1, 7.0, 7.1, 7.2, 7.3, 7.4
March, 2005

Corporate Headquarters

Cisco Systems, Inc.
170 West Tasman Drive
San Jose, CA 95134-1706
USA
<http://www.cisco.com>
Tel: 408 526-4000
800 553-NETS (6387)
Fax: 408 526-4100



THE SPECIFICATIONS AND INFORMATION REGARDING THE PRODUCTS IN THIS MANUAL ARE SUBJECT TO CHANGE WITHOUT NOTICE. ALL STATEMENTS, INFORMATION, AND RECOMMENDATIONS IN THIS MANUAL ARE BELIEVED TO BE ACCURATE BUT ARE PRESENTED WITHOUT WARRANTY OF ANY KIND, EXPRESS OR IMPLIED. USERS MUST TAKE FULL RESPONSIBILITY FOR THEIR APPLICATION OF ANY PRODUCTS.

THE SOFTWARE LICENSE AND LIMITED WARRANTY FOR THE ACCOMPANYING PRODUCT ARE SET FORTH IN THE INFORMATION PACKET THAT SHIPPED WITH THE PRODUCT AND ARE INCORPORATED HEREIN BY THIS REFERENCE. IF YOU ARE UNABLE TO LOCATE THE SOFTWARE LICENSE OR LIMITED WARRANTY, CONTACT YOUR CISCO REPRESENTATIVE FOR A COPY.

The Cisco implementation of TCP header compression is an adaptation of a program developed by the University of California, Berkeley (UCB) as part of UCB's public domain version of the UNIX operating system. All rights reserved. Copyright © 1981, Regents of the University of California.

NOTWITHSTANDING ANY OTHER WARRANTY HEREIN, ALL DOCUMENT FILES AND SOFTWARE OF THESE SUPPLIERS ARE PROVIDED "AS IS" WITH ALL FAULTS. CISCO AND THE ABOVE-NAMED SUPPLIERS DISCLAIM ALL WARRANTIES, EXPRESSED OR IMPLIED, INCLUDING, WITHOUT LIMITATION, THOSE OF MERCHANTABILITY, FITNESS FOR A PARTICULAR PURPOSE AND NONINFRINGEMENT OR ARISING FROM A COURSE OF DEALING, USAGE, OR TRADE PRACTICE.

IN NO EVENT SHALL CISCO OR ITS SUPPLIERS BE LIABLE FOR ANY INDIRECT, SPECIAL, CONSEQUENTIAL, OR INCIDENTAL DAMAGES, INCLUDING, WITHOUT LIMITATION, LOST PROFITS OR LOSS OR DAMAGE TO DATA ARISING OUT OF THE USE OR INABILITY TO USE THIS MANUAL, EVEN IF CISCO OR ITS SUPPLIERS HAVE BEEN ADVISED OF THE POSSIBILITY OF SUCH DAMAGES.

CCSP, CCVP, the Cisco Square Bridge logo, Follow Me Browsing, and StackWise are trademarks of Cisco Systems, Inc.; Changing the Way We Work, Live, Play, and Learn, and iQuick Study are service marks of Cisco Systems, Inc.; and Access Registrar, Aironet, ASIST, BPX, Catalyst, CCDA, CCDP, CCIE, CCIP, CCNA, CCNP, Cisco, the Cisco Certified Internetwork Expert logo, Cisco IOS, Cisco Press, Cisco Systems, Cisco Systems Capital, the Cisco Systems logo, Cisco Unity, Empowering the Internet Generation, Enterprise/Solver, EtherChannel, EtherFast, EtherSwitch, Fast Step, FormShare, GigaDrive, GigaStack, HomeLink, Internet Quotient, IOS, IP/TV, iQ Expertise, the iQ logo, iQ Net Readiness Scorecard, LightStream, Linksys, MeetingPlace, MGX, the Networkers logo, Networking Academy, Network Registrar, *Packet*, PIX, Post-Routing, Pre-Routing, ProConnect, RateMUX, ScriptShare, SlideCast, SMARTnet, StrataView Plus, TeleRouter, The Fastest Way to Increase Your Internet Quotient, and TransPath are registered trademarks of Cisco Systems, Inc. and/or its affiliates in the United States and certain other countries.

All other trademarks mentioned in this document or Website are the property of their respective owners. The use of the word partner does not imply a partnership relationship between Cisco and any other company. (0502R)

Cisco MGCP IP Phone Administrator Guide

Copyright © 2004-2005 Cisco Systems, Inc. All rights reserved.



Preface vii

Overview	vii
Who Should Use This Guide	vii
Objectives	viii
Document Organization	viii
Document Conventions	viii
Related Documentation	ix
Obtaining Documentation	x
Cisco.com	x
Ordering Documentation	x
Documentation Feedback	xi
Obtaining Technical Assistance	xi
Cisco TAC Website	xi
Opening a TAC Case	xi
TAC Case Priority Definitions	xii
Obtaining Additional Publications and Information	xii

CHAPTER 1

Product Overview 1-1

New Information in This Release	1-1
Cisco IP 7960G/7940G Phone Overview	1-2
Media Gateway Control Protocol Overview	1-6
BTXML Support	1-7
Cisco CallManager XML Support	1-7
Supported Network Features	1-7
Supported Codecs and Dual Tone Multifrequency	1-8
Dialing and Messaging Features	1-8
Supported MGCP Commands	1-8
Supported Languages and Character Set	1-9
Supported Protocols	1-10
Where to Go Next	1-11

CHAPTER 2

Installing Cisco IP 7960G/7940G Phone Hardware on the Desktop or Wall 2-1

- Placing the Phone on the Desktop 2-1
- Installing the Phone on the Wall 2-1
- Cabling the Phone Ports 2-2
- Using the Phone with a Cisco Catalyst Switch 2-3
- Connecting the Phone to Power 2-4
- Where to Go Next 2-5

CHAPTER 3

Initializing Cisco MGCP IP Phones 3-1

- Prerequisites 3-1
- Overview of the Initialization Process 3-2
- Information About Configuration Files 3-4
- How to Customize the Default Configuration File 3-5
- How to Customize a Phone-Specific Configuration File 3-8
- How to Customize the Configuration from the Phone Menu 3-10
 - Unlocking and Locking the Phone 3-11
 - Setting and Restoring Network Parameters 3-12
 - Setting and Restoring Phone-Specific Parameters 3-13
 - Setting End-User Call Preferences 3-14
- How to Set the Date and Time 3-14
 - Time-Zone Configuration Examples 3-18
- How to Verify Initialization 3-19
- Where to Go Next 3-20

CHAPTER 4

Managing Cisco MGCP IP Phones 4-1

- How to Customize Cisco IP 7960G/7940G Phone Rings 4-1
- How to Access XML Cards 4-2
- How to View Your Cisco MGCP IP Phone Firmware Image Version 4-2
- How to Upgrade Your Cisco MGCP IP Phone Firmware Image 4-3
 - Upgrading to Versions 7.0 and Later Releases 4-5
 - Upgrading with New Features 4-5
 - MGCP NAT Support 4-6
- How to Upgrade Your Cisco MGCP IP Phone Firmware Image and Reboot Remotely 4-6
- Where to Go Next 4-7

CHAPTER 5

Monitoring Cisco MGCP IP Phones 5-1

- How to Use the Command-Line Interface to Monitor Phones 5-1

Output Examples 5-6

How to Use the Phone Menus to Access Status Information 5-7

Viewing Status Messages 5-7

Viewing Network Statistics 5-7

APPENDIX A**Technical Specifications of the Cisco IP 7960G/7940G Phone A-1**

Physical and Operating Environment Specifications A-1

Cable Specifications A-2

Regulatory Safety Compliance A-2

Connection Specifications A-2

APPENDIX B**Configurable Parameters for the MGCP IP Phone B-1**



Preface

This administrator guide describes the Cisco IP 7960G/7940G phones in a Media Gateway Control Protocol (MGCP) network. This preface describes the objectives and organization of the document and explains how to find additional information on related products and services. It contains the following sections:

- Overview, page vii
- Who Should Use This Guide, page vii
- Objectives, page viii
- Document Organization, page viii
- Related Documentation, page ix
- Document Conventions, page viii
- Obtaining Documentation, page x
- Documentation Feedback, page xi
- Obtaining Technical Assistance, page xi
- Obtaining Additional Publications and Information, page xii

Overview

The *Cisco MGCP IP Phone Administrator Guide* provides information about how to set up, cable, and configure a Cisco IP 7960G/7940G phone in an MGCP network. It also provides information on how to configure the network and MGCP parameters and change the settings and options of the Cisco IP phone.

Who Should Use This Guide

Network engineers, system administrators, Cisco partners, and telecommunications engineers should use this guide to learn the tasks required to set up the Cisco IP phone in an MGCP network. The described tasks are administration-level tasks and are not intended for the end users of the phones. Many of the tasks involve configuring network settings that could affect the ability of the phone to function in the network and require an understanding of IP networking and telephony concepts.

Objectives

This guide provides necessary information to get the Cisco IP phone operational in an MGCP network. It is not intended to provide information on how to implement an MGCP or a VoIP network. For information on implementing MGCP and VoIP networks, refer to the documents listed in the “Related Documentation” section on page ix.

Document Organization

This document is organized into the following chapters and appendixes:

- Chapter 1, “Product Overview”—Describes the MGCP protocol and the Cisco 7960G/7940G phone.
- Chapter 2, “Installing Cisco IP 7960G/7940G Phone Hardware on the Desktop or Wall”—Describes how to install phone hardware.
- Chapter 3, “Initializing Cisco MGCP IP Phones”—Describes how to install firmware, customize configuration files, and connect the phone.
- Chapter 4, “Managing Cisco MGCP IP Phones”—Describes how to upgrade firmware and perform other management tasks.
- Chapter 5, “Monitoring Cisco MGCP IP Phones”—Describes how to debug and troubleshoot.
- Appendix A, “Technical Specifications of the Cisco IP 7960G/7940G Phone”—Provides physical and operating environment specifications, cable specifications, and connection specifications.
- Appendix B, “Configurable Parameters for the MGCP IP Phone”—Lists and describes configurable parameters.

Document Conventions

This document uses the following conventions:

- Commands and keywords are in **boldface** font.
- Arguments for which you supply values are in *italic* font.
- Elements in square brackets ([]) are optional.
- Required alternative keywords are grouped in braces and are separated by vertical bars (for example, {**x** | **y** | **z**}).
- Optional alternative keywords are grouped in brackets and are separated by vertical bars (for example, [**x** | **y** | **z**]).
- Terminal sessions and information that the system displays are in `screen` font.
- Information that you must enter is in **boldface screen** font.
- Buttons and menus that are called out in text in an imperative context are in **boldface** font.

**Note**

Means *reader take note*. Notes contain helpful suggestions or references to material not covered in the publication.

**Caution**

Means *reader be careful*. In this situation, you might do something that could result in equipment damage or loss of data.

**Warning**

This warning symbol means danger. You are in a situation that could cause bodily injury. Before you work on any equipment, be aware of the hazards involved with electrical circuitry and be familiar with standard practices for preventing accidents. To see translations of the warnings that appear in this publication, refer to the translated safety warnings that accompanied this device.

Related Documentation

Cisco IP Phone 7960 and Cisco IP Phone 7940

- *Cisco IP Phone 7960 and 7940 Series at a Glance*
http://www.cisco.com/univercd/cc/td/doc/product/voice/c_ipphon/english/ipp7960/6040atag.pdf
- *Installing the Wall Mount Kit on the Cisco IP Phone*
http://www.cisco.com/univercd/cc/td/doc/product/voice/c_ipphon/english/ipp7960/ippmount.htm

Implementing a VoIP Network

- *Cisco IOS Voice Configuration Library*
<http://www.cisco.com/univercd/cc/td/doc/product/software/ios123/123cgcr/vcl.htm>
- *Cisco IOS Voice Command Reference*
<http://www.cisco.com/univercd/cc/td/doc/product/software/ios123/123tcr/123tvr/>
- *Cisco IOS IP Configuration Guide*
http://www.cisco.com/univercd/cc/td/doc/product/software/ios123/123cgcr/ip_vcg.htm
- *Cisco IOS IP Command Reference, Volume 1 of 4: Addressing and Services*
<http://www.cisco.com/univercd/cc/td/doc/product/software/ios123/123tcr/123tip1r/>
- *Cisco IOS IP Command Reference, Volume 2 of 4: Routing Protocols*
<http://www.cisco.com/univercd/cc/td/doc/product/software/ios123/123tcr/123tip2r/>
- *Cisco IOS IP Command Reference, Volume 3 of 4: Multicast*
<http://www.cisco.com/univercd/cc/td/doc/product/software/ios123/123tcr/123tip3r/>
- *Cisco IOS IP Command Reference, Volume 4 of 4: IP Mobility*
<http://www.cisco.com/univercd/cc/td/doc/product/software/ios123/123tcr/123tip4r/>

BTXML

- *Cisco IP Phone MGCP BTXML Version 2.0 Application Development Guide*
http://www.cisco.com/univercd/cc/td/doc/product/voice/c_ipphon/english/ipp7960/addprot/mgcp/ppdevgd/btxml.htm

Tones

- Telcordia document GR-506-CORE, *Signaling for Analog Interfaces*
<http://telecom-info.telcordia.com>
- *Cisco BTS 10200 Softswitch System Description*
<http://www.cisco.com/univercd/cc/td/doc/pcat/bts10200.htm>

**Note**

Access to the Cisco BTS 10200 Softswitch System technical documentation set is restricted. Contact your Cisco representative for access information.

Upgrading Firmware

- *Cisco 7940 and 7960 IP Phones Firmware Upgrade Matrix*
http://www.cisco.com/univercd/cc/td/doc/product/voice/c_ipphon/english/ipp7960/addprot/mgcp/rmwrup.htm
- *Cisco MGCP IP Phone 7960/7940 Release Notes*

**Note**

Be sure to consult your call agent (CA) documentation for information on features that may be specific to your CA.

Obtaining Documentation

Cisco documentation and additional literature are available on Cisco.com. Cisco also provides several ways to obtain technical assistance and other technical resources. These sections explain how to obtain technical information from Cisco Systems.

Cisco.com

You can access the most current Cisco documentation on the World Wide Web at this URL:

<http://www.cisco.com/univercd/home/home.htm>

You can access the Cisco website at this URL:

<http://www.cisco.com>

International Cisco websites can be accessed from this URL:

http://www.cisco.com/public/countries_languages.shtml

Ordering Documentation

You can find instructions for ordering documentation at this URL:

http://www.cisco.com/univercd/cc/td/doc/es_inpk/pdi.htm

You can order Cisco documentation in these ways:

- Registered Cisco.com users (Cisco direct customers) can order Cisco product documentation from the Ordering tool:
<http://www.cisco.com/en/US/partner/ordering/index.shtml>
- Nonregistered Cisco.com users can order documentation through a local account representative by calling Cisco Systems Corporate Headquarters (California, USA) at 408 526-7208 or, elsewhere in North America, by calling 800 553-NETS (6387).

Documentation Feedback

You can submit e-mail comments about technical documentation to bug-doc@cisco.com.

You can submit comments by using the response card (if present) behind the front cover of your document or by writing to the following address:

Cisco Systems
Attn: Customer Document Ordering
170 West Tasman Drive
San Jose, CA 95134-9883

We appreciate your comments.

Obtaining Technical Assistance

For all customers, partners, resellers, and distributors who hold valid Cisco service contracts, the Cisco Technical Assistance Center (TAC) provides 24-hour-a-day, award-winning technical support services, online and over the phone. Cisco.com features the Cisco TAC website as an online starting point for technical assistance. If you do not hold a valid Cisco service contract, please contact your reseller.

Cisco TAC Website

The Cisco TAC website provides online documents and tools for troubleshooting and resolving technical issues with Cisco products and technologies. The Cisco TAC website is available 24 hours a day, 365 days a year. The Cisco TAC website is located at this URL:

<http://www.cisco.com/tac>

Accessing all the tools on the Cisco TAC website requires a Cisco.com user ID and password. If you have a valid service contract but do not have a login ID or password, register at this URL:

<http://tools.cisco.com/RPF/register/register.do>

Opening a TAC Case

Using the online TAC Case Open Tool is the fastest way to open P3 and P4 cases. (P3 and P4 cases are those in which your network is minimally impaired or for which you require product information.) After you describe your situation, the TAC Case Open Tool automatically recommends resources for an immediate solution. If your issue is not resolved using the recommended resources, your case will be assigned to a Cisco TAC engineer. The online TAC Case Open Tool is located at this URL:

<http://www.cisco.com/tac/caseopen>

For P1 or P2 cases (P1 and P2 cases are those in which your production network is down or severely degraded) or if you do not have Internet access, contact Cisco TAC by telephone. Cisco TAC engineers are assigned immediately to P1 and P2 cases to help keep your business operations running smoothly.

To open a case by telephone, use one of the following numbers:

Asia-Pacific: +61 2 8446 7411 (Australia: 1 800 805 227)

EMEA: +32 2 704 55 55

USA: 1 800 553-2447

For a complete listing of Cisco TAC contacts, go to this URL:
<http://www.cisco.com/warp/public/687/Directory/DirTAC.shtml>

TAC Case Priority Definitions

To ensure that all cases are reported in a standard format, Cisco has established case priority definitions.

Priority 1 (P1)—Your network is “down” or there is a critical impact to your business operations. You and Cisco will commit all necessary resources around the clock to resolve the situation.

Priority 2 (P2)—Operation of an existing network is severely degraded, or significant aspects of your business operation are negatively affected by inadequate performance of Cisco products. You and Cisco will commit full-time resources during normal business hours to resolve the situation.

Priority 3 (P3)—Operational performance of your network is impaired, but most business operations remain functional. You and Cisco will commit resources during normal business hours to restore service to satisfactory levels.

Priority 4 (P4)—You require information or assistance with Cisco product capabilities, installation, or configuration. There is little or no effect on your business operations.

Obtaining Additional Publications and Information

Information about Cisco products, technologies, and network solutions is available from various online and printed sources.

- Cisco Marketplace provides a variety of Cisco books, reference guides, and logo merchandise. Go to this URL to visit the company store:
<http://www.cisco.com/go/marketplace/>
- The *Cisco Product Catalog* describes the networking products offered by Cisco Systems, as well as ordering and customer support services. Access the Cisco Product Catalog at this URL:
<http://cisco.com/univercd/cc/td/doc/pcat/>
- *Cisco Press* publishes a wide range of general networking, training and certification titles. Both new and experienced users will benefit from these publications. For current Cisco Press titles and other information, go to Cisco Press online at this URL:
<http://www.ciscopress.com>
- *Packet* magazine is the Cisco quarterly publication that provides the latest networking trends, technology breakthroughs, and Cisco products and solutions to help industry professionals get the most from their networking investment. Included are networking deployment and troubleshooting tips, configuration examples, customer case studies, tutorials and training, certification information, and links to numerous in-depth online resources. You can access Packet magazine at this URL:
<http://www.cisco.com/packet>
- *iQ Magazine* is the Cisco bimonthly publication that delivers the latest information about Internet business strategies for executives. You can access iQ Magazine at this URL:
<http://www.cisco.com/go/iqmagazine>

- *Internet Protocol Journal* is a quarterly journal published by Cisco Systems for engineering professionals involved in designing, developing, and operating public and private internets and intranets. You can access the Internet Protocol Journal at this URL:
<http://www.cisco.com/ipj>
- Training—Cisco offers world-class networking training. Current offerings in network training are listed at this URL:
<http://www.cisco.com/en/US/learning/index.html>



Product Overview

This chapter contains the following information about the Cisco IP 7960G/7940G phone:

- New Information in This Release, page 1-1
- Cisco IP 7960G/7940G Phone Overview, page 1-2
- Media Gateway Control Protocol Overview, page 1-6
- BTXML Support, page 1-7
- Cisco CallManager XML Support, page 1-7
- Supported Network Features, page 1-7
- Supported Codecs and Dual Tone Multifrequency, page 1-8
- Dialing and Messaging Features, page 1-8
- Supported MGCP Commands, page 1-8
- Supported Languages and Character Set, page 1-9
- Supported Protocols, page 1-10
- Where to Go Next, page 1-11

New Information in This Release

The following is new with this release of the Cisco MGCP IP 7960G/7940G phone:

Release 6.0

- New digital-signal-processor (DSP) firmware.
- DSP alarm-status and error-message-reporting capabilities using the **debug dsp** and **show dsp** commands. You can log your session, by means of console or Telnet, and save the log to a file.
- DHCP option 60 has been added so that the phone can identify itself with vendor-specific information.
- Personal directory functionality for storing up to 32 unique numbers. The **Add** softkey allows you to enter a name and number.
- A new clear message-waiting indicator (MWI) command for use with a console and Telnet.

Release 6.1

- DHCP option 61 has been added so that the phone can identify itself with vendor-specific information.

- New configurable parameters have been added. See Appendix B, “Configurable Parameters for the MGCP IP Phone.”

Release 7.0 and 7.1

- Universal application loader functionality has been added.
- Microphone sensitivity has been increased.
- UDP Fragmentation has been increased to 2434 bytes.
- New upgrade procedures are provided for Version 7.0 and 7.1. See the “Upgrading to Versions 7.0 and Later Releases” section on page 4-5 of Chapter 4, “Managing Cisco MGCP IP Phones.”

Release 7.3 and 7.4

MGCP NAT support has been added. See the MGCP NAT Support section of Chapter 4, “Managing Cisco MGCP IP Phones.”

Caveats for all releases can be found on the product release notes page at the following URL:

http://www.cisco.com/univercd/cc/td/doc/product/voice/c_ipphon/english/ipp7960/addprot/mgcp/relnotes/

Cisco IP 7960G/7940G Phone Overview

Cisco IP 7960G/7940G phones are full-featured telephones that can be plugged directly into an MGCP network and can be used very much like a standard PBX telephone. The Cisco IP 7960G/7940G phone terminals can attach to the existing data network infrastructure, using 10BASE-T and 100BASE-T interfaces on an Ethernet switch.

When used with a voice-capable Ethernet switch, one that understands type of service (ToS) bits and can prioritize VoIP traffic, the phones eliminate the need for a traditional proprietary telephone set and key system or PBX.

The phone works with a third-party call agent (CA) that uses Media Gateway Control Protocol (MGCP) for call control and Basic Telephony eXtensible Markup Language (BTXML) for control of the phone displays and feature keys. Refer to your CA documentation for descriptions of all other phone features, displays, and applications that are not described in this guide.

The Cisco IP 7960G/7940G phone also supports an adjustable ring tone, a hearing-aid compatible handset, and a headset.

See Figure 1-1 and Figure 1-2 to identify the buttons and hardware on your Cisco IP phone.











Figure 1-1 Cisco IP Phone 7960



Figure 1-2 Cisco IP Phone 7940



1	Handset with indicator light	The light strip at the top of the handset blinks when the phone rings and can be set to remain lit when there is a voice message.
2	LCD screen	Displays information about the Cisco IP phone, such as the time, date, phone number, caller ID, line and call status, and the soft key tabs. The screen is 4.25 x 3 inches (10.79 x 7.62 cm) and has an adjustable contrast.
3	Cisco IP Phone model type	Indicates the Cisco IP phone model.
4	Line or speed-dial button	Opens a new line or speed-dials the number on the LCD screen. Phones in the Cisco IP Phone 7960 series have six line or speed-dial buttons, and phones in the 7940 series have two.

5	Footstand adjustment	Allows adjustment of the angle of the phone base.
6	Directories button 	Provides access to call histories and directories.
7	i or ? button 	Provides online help for selected keys or features and network statistics about the active call. Pressing the button and then the up or down scroll key displays a descriptor of the key. For example, pressing the i or ? button, and then the up or down scroll key displays a screen that instructs you how to scroll up and down on the LCD.
8	Settings button 	Provides access to phone settings such as contrast and ring sound, network configuration, and status information.
9	Speaker button 	Toggles the speaker on or off.
10	Mute button 	Toggles the mute on or off.
11	Headset button 	Toggles the headset on or off.
12	Volume button 	Increases or decreases the volume for the handset, headset, or speakerphone (depending upon which is currently active). Also controls the ringer volume (if the handset is in its cradle) and the LCD screen contrast.
13	Services button 	Provides access to any available phone services.
14	Messages button 	Provides access to a message system, if available.
15	Navigation button 	Allows scrolling through text and selection of features displayed on the LCD screen.
16	Dial pad	Works exactly like the dial pad on a traditional telephone.
17	Soft keys	Activates any functions displayed on the corresponding LCD screen tabs. Soft keys point to feature options displayed along the bottom of the LCD screen.

**Note**

Refer to your call-agent (CA) or service-provider documentation for additional functionality.

Figure 1-3 shows the connections on the back of the Cisco IP phone. Cisco IP 7960G/7940G phones have the same hardware configuration.

Figure 1-3 Cisco IP Phone Cable Connection

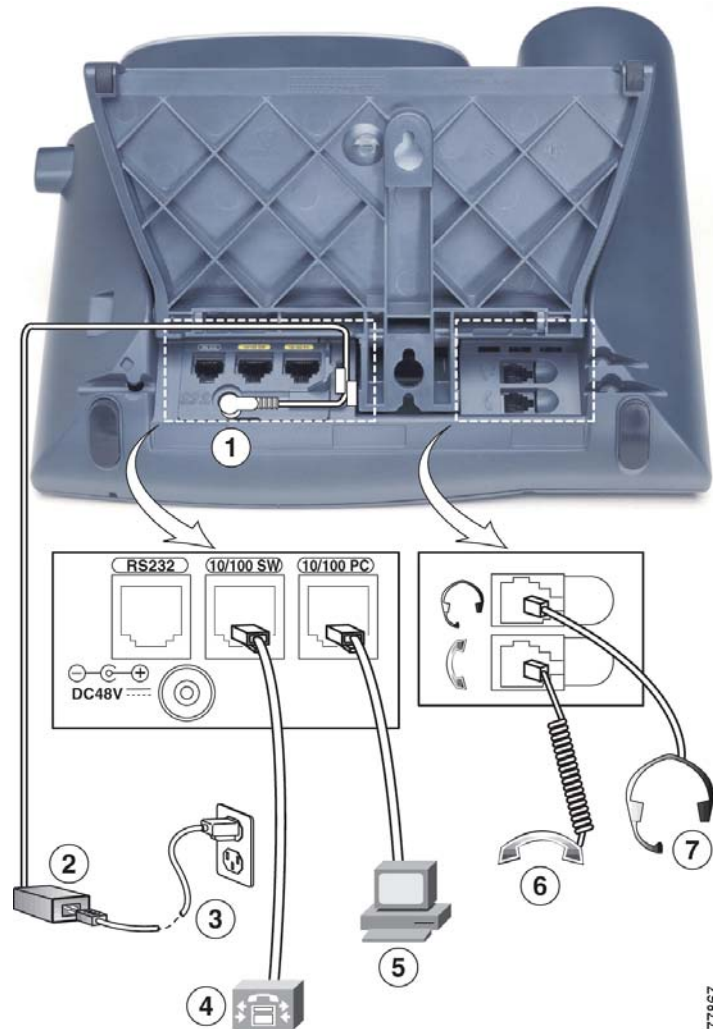

- | | |
|---|---|
| 1 | AC/DC adapter port (DC48V) for power connector. For redundancy, you can use the AC adapter even if you are using inline power from Cisco Catalyst switches. The Cisco IP 7960G/7940G phone can share the power being used from the inline power and external power source. If either the inline power or the external power goes down, the phone can switch entirely to the other power source. |
| 2 | Power supply with AC plug. |
| 3 | Power cable with wall socket plug for connecting to power. |
| 4 | Network port (10 and 100 SW) RJ-45 to connect the phone to the network supporting 10- or 100-Mbps half- or full-duplex Ethernet connections to external devices. You can use either Category 3 or Category 5 cabling for 10-Mbps connections, but use Category 5 for 100-Mbps connections. To avoid collisions, use full-duplex mode. You must use a straight-through cable on this port. The phone can also obtain inline power from the Cisco Catalyst switch over this connection. |

5	Access port (10 and 100 PC) RJ-45 to connect a network device, such as a computer, to the phone supporting from 10- to 100-Mbps half- or full-duplex Ethernet connections to external devices. You can use either Category 3 or Category 5 cabling for 10-Mbps connections, but use Category 5 for 100-Mbps connections. To avoid collisions, use full-duplex mode. You must use a straight-through cable on this port.
6	Handset port for connecting a handset.
7	<p>Headset port for connecting a headset. Enables the headset. The phone supports a four- or six-wire headset jack. The volume and mute controls also adjust volume to the earpiece and mute the speech path of the headset. The headset activation key is located on the front of the Cisco IP 7960G/7940G phone.</p> <p>The phone supports the following Plantronics four- or six-wire headsets: Tristar Monaural, Encore Monaural H91, and Encore Binaural H101.</p> <p>When a headset is used, an amplifier is not required. However, a coil cord is required to connect the headset to the headset port on the back of your Cisco IP 7960G/7940G phone. For information on ordering compatible headsets and coil cords for the Cisco IP 7960G/7940G phone, go to http://cisco.getheadsets.com or http://vxicorp.com/cisco.</p>

Media Gateway Control Protocol Overview

Media Gateway Control Protocol (MGCP) is the Internet Engineering Task Force (IETF) standard for multimedia conferencing over IP. MGCP is an ASCII-based, application-layer control protocol (defined in RFC 2705) that can be used to establish, maintain, and terminate calls between two or more endpoints.

Like other VoIP protocols, MGCP is designed to address the functions of signaling and session management within a packet telephony network. Signaling allows call information to be carried across network boundaries. Session management provides the ability to control the attributes of an end-to-end call.

One aspect of MGCP that differs from other VoIP protocols is that MGCP relies on a control server, or call agent (CA), to control call progression, tones to apply, and call characteristics. MGCP endpoints carry out instructions from the CA, which controls how calls proceed.

MGCP allows a control server to do the following:

- Determine the location of the target endpoint.
- Determine the media capabilities of the target endpoint. Using Session Description Protocol (SDP), MGCP determines the lowest level of common service between the endpoints. Conferences are established using only the media capabilities that can be supported by all endpoints.
- Determine the availability of the target endpoint.
- Establish a session between the originating and target endpoint. If the call can be completed, MGCP establishes a session between the endpoints. MGCP also supports midcall changes, such as the addition of another endpoint to the conference or the changing of a media characteristic or codec.



Note

Conferences consist of two or more users and can be established by means of multicast or multiple unicast sessions. A conference is an established session (or call) between two or more endpoints. In this document, the terms conference and call are used interchangeably.

MGCP is a client/server protocol. The CA handles all aspects of setting up calls to and from endpoints. CAs or control servers provide the feature capabilities that a particular endpoint can use. Endpoints connected to different CAs likely have a different set of features that they can use. Because all call-control features are in the control server, each control server vendor decides which features are most important, and therefore different control server vendors differ in essential features.

BTXML Support

The Cisco MGCP IP phone supports Basic Telephony eXtensible Markup Language. BTXML defines XML elements for controlling the user interface of an IP telephone. It describes what information is displayed on the screen and how to provide input using soft keys and hard keys.

For information about creating and using BTXML scripts on the phone, refer to the *Cisco IP Phone MGCP BTXML Version 2.0 Application Development Guide*.

Cisco CallManager XML Support

The Cisco MGCP IP phone supports Cisco CallManager XML cards that you configure to provide data such as stock quotes, calendars, and directory lookups. Phone users access this information using phone buttons such as the Services or Directories buttons or soft keys. See Chapter 4, “Managing Cisco MGCP IP Phones,” for information about configuring these cards.

The phone supports Cisco CallManager XML up through version 3.0. It does not support the following XML objects in version 3.1 and later: CiscoIPPhoneIconMenu, CiscoIPPhoneExecute, CiscoIPPhoneError, and CiscoIPPhoneResponse.

For more information about using XML on your Cisco MGCP IP phone, refer to the following:

- IP Telephony
<http://www.hotdispatch.com/cisco-ip-telephony>
- Cisco Call Manager Services Developer Kit
http://www.cisco.com/cgi-bin/dev_support/access_level/product_support
- *Developing Cisco IP Phone Services* by Darrick Deel, Mark Nelson, and Anne Smith, ISBN 1-58705-060-9

Supported Network Features

The Cisco MGCP IP phone supports the following network features. Depending on the features that your CA supports, some of these features may not be available on your phone.

- Interoperability with third-party CAs.
- Up to six MGCP connections and call appearances.
- Network startup using DHCP and TFTP.
- Telnet support—You can configure the phone to use Telnet to connect directly to the phone to debug and troubleshoot. See Chapter 4, “Managing Cisco MGCP IP Phones,” for more information on configuration parameters.
- Ping support—You can ping a specific Cisco IP phone to see if it is operational and how long the response time is from the phone.

- Traceroute support—You can use “traceroute” to see the path that a phone traverses in the route to its desired destination.
- Remote reset support—You can configure a phone to enable a service provider to reset a phone from a remote site. This feature provides a key tool for restarting the phone registration process with the service provider call agent or proxy and for receiving a new or updated configuration or firmware load from a designated TFTP server.

Supported Codecs and Dual Tone Multifrequency

The Cisco MGCP IP phone supports the following codecs:

- G.711 mu-law codec
- G.711 a-law codec
- G.729a codec

The phone also supports dual tone multifrequency (DTMF) out-of-band signaling for G.729a codecs compliant to RFC 2833.

Dialing and Messaging Features

The Cisco MGCP IP phone supports the following dialing and messaging features:

- Message-waiting indication—Lights to indicate that a new voice message is in a subscriber mailbox. If the user listens to the message but does not save or delete it, the light remains on. If a user listens to the message and saves or deletes it, the light goes off. The message-waiting indicator (MWI) is controlled by the voice-mail server. The indication is saved over a phone upgrade or reboot.
- Notified entity—A CA can direct an endpoint to send notify messages to an alternate destination.
- Call waiting, call transfer, call forward (unconditional, busy, no answer), announcement, music on hold, and volume control. These features must be supported by the CA.
- Three-way calling using an external multipoint control unit (MCU). This feature must be supported by the CA.

Supported MGCP Commands

The Cisco MGCP IP phone supports the MGCP commands shown in Table 1-1.

Table 1-1 MGCP Commands

Command	Description	Direction
Notification Request	Specifies events that generate notifications to the CA.	CA to phone
Create Connection	Creates an RTP connection.	CA to phone
Modify Connection	Modifies an existing RTP connection.	CA to phone
Delete Connection	Deletes an endpoint RTP connection.	CA to phone
Audit Endpoint	Queries endpoint status.	CA to phone
Audit Connection	Queries connection status.	CA to phone

Table 1-1 MGCP Commands (continued)

Command	Description	Direction
Restart in Progress	Notifies the CA of the endpoint's service state change.	Phone to CA
Endpoint Configuration	Specifies encoding for audio signals.	CA to phone
Notification	Indicates event occurrences.	Phone to CA

Supported Languages and Character Set

The Cisco MGCP IP phone supports the ISO 8859-1 Latin1 characters and the following languages: French (fr), Spanish (es), Catalan (ca), Basque (eu), Portuguese (pt), Italian (it), Albanian (sq), Rhaeto-Romanic (rm), Dutch (nl), German (de), Danish (da), Swedish (sv), Norwegian (no), Finnish (fi), Faroese (fo), Icelandic (is), Irish (ga), Scottish (gd), English (en), Afrikaans (af), and Swahili (sw).

It does not support the following languages: Zulu (zu) and other Bantu languages using Latin Extended-B letters; Arabic in North Africa; and Guarani (gn), which is missing the letters G, E, I, U, and Y with tildes (~).

You can use ISO 8859-1 Latin1 characters in the following areas:

- Caller ID information—When an MGCP message is received with ISO 8859-1 Latin1 characters in the caller ID strings, those caller ID strings are displayed on the phone LCD with the correct ISO 8859-1 Latin1 characters.
- Cisco CallManager XML—Services menu applications are written in Cisco CallManager XML (CMXML). You can write language-specific applications for a particular region. For example, you can write an application that displays the current weather in Sweden using Swedish language characters. If you write the same application for a Spanish town, the characters you select could translate the application into Spanish.
- Call-control displays (external MGCP XML card deck)—The XML deck used for MGCP call control is downloaded to the phone, and those XML cards can be translated into the local language.
- Line-key labels—Line-key labels are set using an MGCP message that sets the label to the string provided. Strings that contain ISO 8859-1 Latin1 characters are displayed properly.
- Soft-key labels—Soft-key labels are set using XML cards. XML cards, including call-control cards and services applications, can provide soft keys with ISO 8859-1 Latin1 characters.



Note

The *i* button text and the Settings menu are in English. These items are built into the phone image and cannot be changed.

Supported Protocols

The Cisco MGCP IP phone supports the following protocols.

Table 1-2 Supported Protocols

Protocol	Description
DHCP	<p>Dynamic Host Configuration Protocol. Client or manually configured using a local setup menu. DHCP is used to allocate and assign IP addresses. DHCP allows you to move network devices from one subnet to another without administrative attention. It allows connection of Cisco MGCP IP phones to the network so that they become operational without having to manually assign an IP address and additional network parameters.</p> <p>The Cisco MGCP IP phone supports DHCP as defined in RFC 2131. By default, the phone is DHCP-enabled.</p>
DNS	Domain Name System. Used in the Internet for translating names of network nodes into addresses. MGCP uses DNS to resolve the host names of endpoints into IP addresses.
Dynamic DNS and TFTP	You can configure additional DNS and TFTP servers. Upon bootup, the phone first goes to the default TFTP server to download the configuration files. If a new dynamic TFTP server is specified in the files, the phone requests a new set of files from the specified server. If new DNS addresses are specified in the files, the phone uses those addresses for lookups.
HTTP	Hypertext Transfer Protocol. The phone contains limited support for HTTP 1.1. The phone uses HTTP to retrieve Cisco CallManager XML files.
ICMP	Internet Control Message Protocol. A network-layer Internet protocol that enables hosts to send error or control messages to other hosts. ICMP also provides other information relevant to IP packet processing. The Cisco MGCP IP phone supports ICMP as defined in RFC 792.
IP	Internet Protocol. A network layer protocol that sends datagram packets between nodes on the Internet. IP also provides features for addressing, type-of-service (ToS) specification, fragmentation and reassembly, and security. The Cisco MGCP IP phone supports IP as defined in RFC 791.
RTP	Real-Time Transport Protocol. Supports transport of real-time data (such as voice data) over data networks. RTP also has the ability to obtain quality-of-service (QoS) information. The phone supports RTP as a media channel.
SDP	Session Description Protocol. An ASCII-based protocol that describes multimedia sessions and their related scheduling information. Third-party call control is supported using delayed media negotiation, which is SDP data that is not completely advertised in the initial call setup. SDP also supports endpoints specified as fully qualified domain names (FQDNs). The Cisco MGCP IP phone uses SDP for session description.
SNTP	Simple Network Time Protocol. Synchronizes computer clocks on an IP network. Current date and time are supported using SNTP including time zone and daylight saving time. The Cisco MGCP IP phone uses SNTP for date and time support.

Table 1-2 Supported Protocols (continued)

Protocol	Description
TCP	Transmission Control Protocol. Provides a reliable byte-stream transfer service between endpoints on the Internet. The Cisco MGCP IP phone uses TCP for Telnet and HTTP sessions.
TFTP	Trivial File Transfer Protocol. Allows files to be transferred from one computer to another over a network. The Cisco MGCP IP phone uses TFTP to download configuration files and software updates.
ToS	Type of service. An indication of how an upper-layer protocol requires a lower-layer protocol to treat its messages. In SNA subarea routing, ToS definitions are used by subarea nodes to determine the optimal route to establish a given session. A ToS definition comprises a virtual route number and a transmission priority field. Also called class of service (CoS).
UDP	User Datagram Protocol. Exchanges data packets without acknowledgments or guaranteed delivery. An MGCP network can use UDP as the underlying transport protocol. If UDP is used, retransmissions are used to ensure reliability.
VAD	Voice activity detection. When enabled on a voice port or a dial peer, silence is not transmitted over the network, only audible speech. Sound quality is slightly degraded, but the connection monopolizes much less bandwidth.

Where to Go Next

- See Chapter 2, “Installing Cisco IP 7960G/7940G Phone Hardware on the Desktop or Wall,” for placement of the phone on the desktop or wall and for cabling information.
- See Chapter 3, “Initializing Cisco MGCP IP Phones,” for installation of the firmware and connecting the phone to power sources and the network.
- See Chapter 4, “Managing Cisco MGCP IP Phones,” for upgrading firmware and performing other management tasks.
- See Chapter 5, “Monitoring Cisco MGCP IP Phones,” for information on debugging and on viewing network statistics.



Installing Cisco IP 7960G/7940G Phone Hardware on the Desktop or Wall

This chapter explains how to install the Cisco IP 7960G/7940G phone on the desktop or how to mount it to the wall. It provides information on the following:

- Placing the Phone on the Desktop, page 2-1
- Installing the Phone on the Wall, page 2-1
- Cabling the Phone Ports, page 2-2
- Using the Phone with a Cisco Catalyst Switch, page 2-3
- Connecting the Phone to Power, page 2-4
- Where to Go Next, page 2-5

Placing the Phone on the Desktop

You have two options for the location of the Cisco MGCP IP phone: on the desktop or on the wall. The phone includes an adjustable footstand. When placing the phone on a desktop surface, you can adjust the tilt height to several different angles in 7.5-degree increments from flat to 60 degrees. Alternatively, you can mount the phone to the wall using the footstand or using the optional locking accessory.

Installing the Phone on the Wall

You can mount the phone on the wall in either of two ways:

- Using the footstand as a mounting bracket. Use the following procedure to do so.
- Using the optional locking bracket. For instructions, refer to the *Installing the Wall Mount Kit for the Cisco IP Phone* document on Cisco.com.



Note

Mounting the phone on the wall requires a screwdriver and screws to secure the phone to the wall. These tools are not provided as standard equipment.

Procedure

-
- Step 1** Push in the footstand adjustment knob.
- Step 2** Adjust the footstand so that it is flat against the back of the phone, as shown in Figure 2-1.

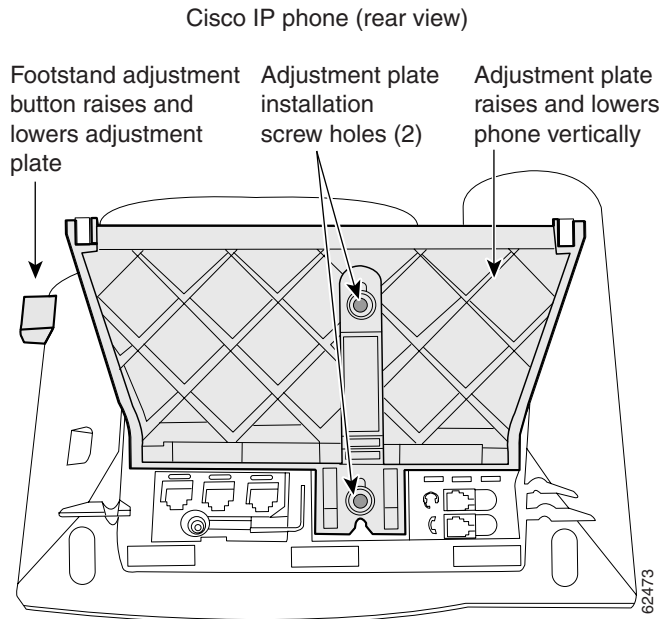
Figure 2-1 Adjusting the Footstand

- Step 3** Modify the handset rest so that the handset remains on the earpiece rest when the phone is vertically placed.
- a. Remove the handset from the earpiece rest.
 - b. Locate the tab (handset wall hook) at the base of the earpiece rest.
 - c. Slide this tab out, rotate it 180 degrees, and reinsert it.
 - d. Place the handset on the earpiece rest.
- Step 4** Insert two screws into a wall stud, matching them to the two screw holes on the back of the footstand. (The screw holes on the footstand fit standard phone jack mounts.)
- Step 5** Hang the phone on the wall.
-

Cabling the Phone Ports

The Cisco MGCP IP phone has several ports on the back of the phone, shown in Figure 1-3 on page 1-5. Plug the appropriate equipment into the appropriate port.

**Caution**

Consider use of an uninterruptible power supply (UPS). Without one, when you use either a local transformer or inline power on the LAN, the phone is inoperable during a power outage. This affects your ability to make emergency calls: 911 in USA and Canada, 999 in the UK, and 112 in mainland Europe.

**Note**

Use of a headset does not require an amplifier. However, it does require a coil cord to connect the headset to the headset port. For information on ordering compatible headsets and coil cords, refer to <http://cisco.getheadsets.com> or <http://vxicorp.com/cisco>.

**Note**

Do not connect the phone to power or the network at this time. Doing so causes the phone to initialize and download firmware and configuration files. Initialization and modification of the configuration files are described in the Chapter 3, “Initializing Cisco MGCP IP Phones.”

Using the Phone with a Cisco Catalyst Switch

To function in the IP telephony network, the Cisco MGCP IP phone must be connected to a networking device, such as a Cisco Catalyst switch, to obtain network connectivity. The phone has an internal Ethernet switch, which enables it to switch traffic that comes from the phone, access port, and network port.

If a computer is connected to the access port, packets that travel to and from the computer and to and from the phone share the same physical link to the switch and the same port on the switch. This configuration has the following implications for the VLAN configuration on the network:

- The current VLANs might be configured on an IP subnet basis, and additional IP addresses might not be available to assign the phone to a port so that it belongs to the same subnet as other devices (PC) connected to the same port.
- Data traffic that is present on the VLAN that supports the phones might reduce the quality of VoIP traffic.

You can resolve these issues by isolating the voice traffic onto a separate VLAN on each of the ports connected to a phone. The switch port configured for connecting a phone would have separate VLANs configured for carrying the following traffic:

- Voice traffic to and from the phone (auxiliary VLAN).
- Data traffic to and from the PC connected to the switch through the access port of the phone (native VLAN).

Isolating the phones on a separate, auxiliary VLAN increases the quality of the voice traffic and allows a large number of phones to be added to an existing network where there are not enough IP addresses.

For redundancy, you can use the Cisco AC adapter even if you are using inline power from the Cisco Catalyst switches. The phone can share the power load being used from the inline power and external power source. If either the inline power or the external power goes down, the phone can switch entirely to the other power source.

To use this redundancy feature, you *must* set the inline power mode to “auto” on the Cisco Catalyst switch. Next, connect the phone to the network without connecting it to an external power source. After the phone powers up, connect the external power supply to the phone.

For more information, refer to the documentation included with the Cisco Catalyst switch.

Connecting the Phone to Power



Warning

Read the installation instructions before you connect the system to its power source.

Waarschuwing Raadpleeg de installatie-aanwijzingen voordat u het systeem met de voeding verbindt.

Varoitus Lue asennusohjeet ennen järjestelmän yhdistämistä virtalähteeseen.

Attention Avant de brancher le système sur la source d'alimentation, consulter les directives d'installation.

Warnung Lesen Sie die Installationsanweisungen, bevor Sie das System an die Stromquelle anschließen.

Avvertenza Consultare le istruzioni di installazione prima di collegare il sistema all'alimentatore.

Advarsel Les installasjonsinstruksjonene før systemet kobles til strømkilden.

Aviso Leia as instruções de instalação antes de ligar o sistema à sua fonte de energia.

¡Advertencia! Ver las instrucciones de instalación antes de conectar el sistema a la red de alimentación.

Warning! Läs installationsanvisningarna innan du kopplar systemet till dess strömförsörjningsenhet.



Caution

When you connect the phone to power, the phone automatically begins startup and initialization. Use this section to determine how you will power your phones. Do not connect the phones to power, though, until you address the prerequisites and follow the configuration instructions in Chapter 3, “Initializing Cisco MGCP IP Phones.”

You can connect the phone to the following power sources:

- External power source—Optional AC adapter and power cord for connecting to a standard wall receptacle.
- WS-X6348-RJ45V 10/100 switching module—Provides inline power to the phone when connected to a Cisco Catalyst 3500, 4000, or 6000 family 10/100BASE-TX switching module. This module sends power on pins 1 and 2, and 3 and 6.
- WS-PWR-PANEL—Power patch panel provides power to the phone, which allows the phone to be connected to existing Cisco Catalyst 4000, 5000, or 6000 family 10/100BASE-TX switching modules. This module sends power on pins 4, 5, 7, and 8.
- WS-X4148-RJ45V—48-port 10/100 Ethernet with inline power module for the Cisco Catalyst 4006 switch.
- WS-X4095-PEM—VoIP DC Power Entry module for the Cisco Catalyst 4006 switch.
- WS-X4608-2PSU and WS-X4608—External –48VDC power shelf common equipment for the Cisco Catalyst 4006 with two AC-to-DC power supply units (PSUs) and one empty bay for redundant option, and the 110-V 15-A AC-to-48VDC PSU redundant option for the power shelf.
- WS-C3524-PWR-XL-EN—Cisco Catalyst 3524-PWR XL switch.

**Note**

- Only the network port (labeled 10/100 SW) supports inline power from the Cisco Catalyst switches.
- If you are using a Cisco Catalyst switch to provide power, see the “Using the Phone with a Cisco Catalyst Switch” section on page 2-3.

Where to Go Next

- See Chapter 3, “Initializing Cisco MGCP IP Phones,” for installation of the firmware and connecting the phone to power sources and the network.
- See Chapter 4, “Managing Cisco MGCP IP Phones,” for information on upgrading firmware and performing other management tasks.
- See Chapter 5, “Monitoring Cisco MGCP IP Phones,” for information on debugging and on viewing network statistics.



Initializing Cisco MGCP IP Phones

This chapter describes the initial firmware installation tasks and configuration process for the Cisco IP 7960G/7940G phone in a Media Gateway Control Protocol (MGCP) network. It provides information on the following:

- Prerequisites, page 3-1
- Overview of the Initialization Process, page 3-2
- Information About Configuration Files, page 3-4
- How to Customize the Default Configuration File, page 3-5
- How to Customize a Phone-Specific Configuration File, page 3-8
- How to Customize the Configuration from the Phone Menu, page 3-10
- How to Set the Date and Time, page 3-14
- How to Verify Initialization, page 3-19
- Where to Go Next, page 3-20

Prerequisites

Installation Strategy

Choose one of the following installation strategies:

- Download, then customize. Download the firmware image and configuration files to your TFTP server. Connect each phone to power, causing it to automatically download the image and default files. Configure each phone individually as needed.
- Customize, then download. Download the firmware image and configuration files to your TFTP server. Open the configuration files and customize parameters for all the phones at once. Save the customized file to the TFTP server. Connect each phone to power, causing it to automatically download the image and customized files.

Network Functionality

Ensure that your network meets the following requirements:

- A working IP network is established and configured for MGCP.

For information on configuring IP, refer to the *Cisco IOS IP Configuration Guide*.

http://www.cisco.com/univercd/cc/td/doc/product/software/ios123/123cgcr/ip_vcg.htm

- VoIP is configured on your Cisco routers.

For information on configuring VoIP, refer to the *Cisco IOS Voice Configuration Library*.
<http://www.cisco.com/univercd/cc/td/doc/product/software/ios123/123cgr/vcl.htm>

- A TFTP server is configured on your network.

When the phone initializes, it requests the following from the TFTP server:

- Latest firmware image
- Dual-boot file (OS79XX.TXT)
- Phone-specific MAC-address configuration file
- Default configuration file
- Ring-list file
- Dial-plan file

For the information about configuring your TFTP server, refer to your operating-system documentation.

- A DHCP server is configured on your network.

The phone uses DHCP to obtain IP addresses. Configuration options are as follows:

- dhcp option #1 (IP subnet mask)
- dhcp option #3 (default IP gateway)
- dhcp option #6 (DNS server IP address)
- dhcp option #15 (domain name)
- dhcp option #50 (IP address)
- dhcp option #66 (TFTP server IP address)

If you do not configure DHCP options on the DHCP server, you must manually configure them on the phone. For information on configuring a DHCP server, refer to your operating-system documentation.

- A proxy server is active and configured to receive and forward messages.



Note

Refer to the *Cisco 7940 and 7960 IP Phones Firmware Upgrade Matrix* for additional prerequisites.

Overview of the Initialization Process

The initialization process for the Cisco MGCP IP phone establishes network connectivity and makes the phone operational in your MGCP network. After you connect your phone to the network and to a power supply, the phone begins initialization, during which the following occurs:

1. The phone loads the firmware image.

The phone has nonvolatile flash memory that contains permanent factory information about the phone and, eventually, firmware images and user-defined preferences. During initialization, the phone runs a bootstrap loader that loads the firmware image.

2. The phone learns its VLAN membership.

If the phone is connected to a Cisco Catalyst switch, the switch notifies the phone of the voice VLAN defined on the switch. The phone needs to know its VLAN membership before it can send a DHCP request for its IP settings (if using DHCP).

3. The phone acquires its IP address.

If the phone uses DHCP to obtain IP settings, it queries the DHCP server. Otherwise, it uses IP settings that are stored in flash memory.

4. The phone contacts the TFTP server and downloads the following files (or uses settings that are stored in its flash memory):

- SEP<macaddress>.cnf.xml—Creates the filename SEP<macaddress>.cnf.xml on the TFTP server into which you can place one of the following:

```
<device>
<loadInformation>POM3-07-3-00</loadInformation>
</device>
```

The phone then checks the load information and either upgrades the phone firmware in FLASH memory to the version stated in the <LoadInformation> tag using the TFTP loader in the Universal Application Loader, or, if the version matches, exits the Universal Application Loader and executes the firmware already loaded in FLASH memory.

- <firmware-version>.loads—If the version matches, enables the phone to exit the Universal Application Loader and executes the firmware already loaded in FLASH memory, as defined in SEP<macaddress>.cnf.xml.
- OS79XX.TXT—Enables the phone to initialize and automatically determine the network in which it is being installed.

Note

The use of dual boot file OS79XX.TXT is deprecated in favor of individual XML configuration files for the phone using their SEP<macaddress>.cnf.xml style names. This allows Cisco CallManager and MGCP-based configurations to share a common TFTP server, as the XML configuration is phone-specific and allows individual phones to be switched between SIP, SCCP, or MGCP images.

- MGCPDefault.cnf—Contains parameters intended for all phones. For information on customizing the file, see the “How to Customize the Default Configuration File” section on page 3-5.
- MGC<mac-addr>.cnf—Contains parameters specific to a phone. Use this file as a template from which to create a file for each phone. Insert the MAC address of the phone in the filename.
- RINGLIST.DAT—Lists audio files that are the custom-ring-type options for the phones. The files must be in the root directory of the TFTP server.
- dialplan.xml—Contains the North American sample dial plan. You can push the file down to the phones with a notify (NTFY) message with a check-sync Event header.

Note

Refer to the *Cisco 7940 and 7960 IP Phones Firmware Upgrade Matrix* for additional information.

5. The phone verifies the firmware version.

If the phone determines that the image defined in a configuration file differs from the image that it has stored in flash memory, it performs a firmware upgrade. During upgrade, the phone downloads the firmware image from the TFTP server, programs the image into flash memory, and reboots.



Note Upon startup, the phone attempts to download both configuration files. If neither file exists, a TFTP timeout occurs after approximately 9 seconds per file. If the files exist, they are parsed and processed. These files are not required for the phone to initialize; however, it takes longer (approximately 20 seconds) for the phone to boot because it is waiting for the timeout on the TFTP server. Both configuration files can use the same values or they can contain empty values. If the files contain empty values, the phone boots using default values for some of the parameters.



Note Values in the phone-specific configuration file take precedence over those in the default configuration file because the phone-specific file is processed last.

Information About Configuration Files

Configuration files reside in a TFTP server subdirectory (you specify the location of this subdirectory with the `tftp_cfg_dir` parameter). For more information, refer to the *Cisco 7940 and 7960 IP Phones Firmware Upgrade Matrix*.



Note

Be sure to customize configuration files *before* you power up the phone. When powered up, the phone automatically loads parameters stored in flash memory and then requests configuration files from the TFTP server.

When modifying parameters, remember the following:

- Parameters in the configuration file override those stored in the phone's flash memory.
- Locally changed parameters are used until the next reboot.
- The name of each phone-specific configuration file is unique and is based on the MAC address of the phone.

The format of the filename must be `MGCPXXXXYYYYZZZZ.cnf`, where `XXXXYYYYZZZZ` is the MAC address of the phone. The MAC address must be in uppercase; the `.cnf` extension must be in lowercase (for example, `MGCP00503EFFF842.cnf`).



Note You can find the MAC address of a phone on the middle sticker adhered to the base of the phone. You can also view it on the Network Configuration menu.

- Each line in a configuration file must use the following format and must adhere to the following rules:

```
variable-name : value ; optional comments
```

- Associate only one value with one variable.
- Separate variable names and values with colons.

- Set only one variable per line.
- Indicate the end of a line with `<lf>` or `<cr><lf>`.
- Put the variable and value on the same line, and do not break the line.
- You can include white space before or after a variable or value. You can include any character within them. However, if white spaces are needed within the value, you must enclose the value in single or double quotes. If the value is enclosed in quotes, the end quote must be the same as the start quote.
- You can include comments after the value. Use the semicolon (;) and pound (#) delimiters to distinguish the comments.
- You can include comment lines.
- You can include blank lines.

You can use any case for variables; they are not case sensitive.

How to Customize the Default Configuration File

You have the following installation choices:

- Download, then customize. Download the default configuration file to your TFTP server, and then plug each phone into power and the network. The phones automatically download the default configuration file from the TFTP server. You can then customize parameters if required.
- Customize, then download. Download the default configuration file to your TFTP server, open the file, customize parameters for all the phones at once, save the customized file, and then plug the phones into power and the network. The phones automatically download the customized file from the TFTP server.

This section describes how to customize, then download. Maintaining parameters—such as whether phones must register with a proxy server and the codec that phones must use when initiating a call—in the default configuration file allows you to perform global changes, such as upgrading the image version, without having to customize the phone-specific configuration file for each phone.



Note

For a complete alphabetical list of configurable parameters, see Appendix B, “Configurable Parameters for the MGCP IP Phone.”

Prerequisites

- If you have an existing system from a release earlier than Release 7.0, upgrade your system firmware as described in the “How to Upgrade Your Cisco MGCP IP Phone Firmware Image” section on page 4-3 before proceeding.

Procedure

-
- Step 1** Obtain the default configuration file as follows:
- a. Go to the Cisco.com MGCP IP 7940/7960 phone software-download site at <http://www.cisco.com/cgi-bin/tablebuild.pl/mgcp-ip-phone7960>.
 - b. Download the MGCPDefault.cnf file to the root directory of your TFTP server or to a subdirectory in which all phone-specific configuration files are stored.
- Step 2** Using an ASCII text editor such as vi, open the file.

- Step 3** Modify parameters as needed.
- Step 4** Save the file to the root directory of your TFTP server or to a subdirectory in which all phone-specific configuration files are stored.

Configuration Example

The following is an example of the MGCPDefault configuration file that you downloaded from Cisco.com:

```
# MGCP Default Configuration File
#
# Any or All of these options can be configured
# in the user config file (MGCCConfigGeneric.cnf).
# The user config file options override any options
# specified here in the Default Config File.
# :sample user config file name: MGC003E362FE92.cnf

# image_version - specifies which image version should
# be on the phone. This is used to upgrade from one
# MGCP image to a different MGCP image. The OS79XX.TXT
# file is only used to switch protocols (ie. SIP to MGCP).
image_version: POM3-06-0-00

# tftp_cfg_dir - specifies the directory to use for the
# retrieving the MGCCConfigGeneric.cnf file. The base
# for the directory is the base TFTP Server directory.
# tftp_cfg_dir is limited to 64 characters.
tftp_cfg_dir : ""

# phone_password - specifies the password used to Telnet
# to the phone. phone_password is limited to 32 characters.
# phone_prompt - specifies the prompt the phone will display
# when logged in from the console or Telnet session.
# phone_prompt is limited to 16 characters.
phone_password : "cisco"
phone_prompt : "MGCP Phone"

# sntp_mode - specifies the mode the SNTP server uses
# (unicast, multicast, anycast (default), directedbroadcast)
# sntp_server - specifies the address of the SNTP server
sntp_mode : anycast
sntp_server : "10.18.198.13"

# The following parameters setup time zone and
# daylight savings settings.
# Supported time zones are :
# EST, AST, NST, BST, AT, WAT, GMT, HST, YST
time_zone : EST
dst_offset : 1
dst_start_month : "April"
dst_start_day : 0
dst_start_day_of_week : "Sun"
dst_start_week_of_month : 1
dst_start_time : 2
dst_stop_month : "Oct"
dst_stop_day : 0
dst_stop_day_of_week : "Sun"
dst_stop_week_of_month : 8
dst_stop_time : 2
dst_auto_adjust : 1
```

```
# Date and Time format displays
# time_format_24hr (1 - yes, 0 - 12 hours format)
# date_format (M/D/Y, D/M/Y, Y/M/D, Y/D/M)
time_format_24hr : 1
date_format : M/D/Y

# MGCP Call Agent Information
# mgcp_gw_controller - address of call agent
# mgcp_input_port - port the phone listens on
# mgcp_output_port - port the call agent listens on
mgcp_gw_controller : 10.18.198.13
mgcp_input_port : 2427
mgcp_output_port : 2727

# mgcp_keepalive - specifies if the RSIP keepalive should
# be used to keep NAT bindings open to the Call Agent.
# values are [0 - off (default), 1 - on]
# mgcp_keepalive_timer - specifies the time interval to
# use for the mgcp keepalive timer if turned on.
# values are in seconds [10 to 600, 30 is default].
mgcp_keepalive: 0
mgcp_keepalive_timer: 30

# xml_card_dir - specifies the directory to use for the
# retrieving the xml cards file. The base
# for the directory is the base TFTP Server directory.
# xml_card_dir is limited to 64 characters.
# xml_card_file - specifies the file name of the XML Cards
# file. xml_card_file is limited to 20 characters.
xml_card_dir : ""
xml_card_file : "CARD.XML"

# tos_media - specifies the value to be used for the tos bits.
# valid range is 0-7.
tos_media: 7

#use_mac_name - specifies whether to use the IP address
# or MAC Address in the endpoint name. The default is
# to use the IP address. Valid values are :
# [ 0 - IP Address (default) 1 - Mac Address ]
use_mac_name: 0

#telnet_level - enables the ability to Telnet into phone
# and specify the level of access. The default is
# disabled. Valid values are:
# [ 0-disabled (default), 1-enabled, 2-privileged ]
telnet_level: 0

#logo_url - used to put a specific windows 256-color bmp
# file as the background image. The image must be a
# windows 256 color bitmap. The space allotted for the image
# is 56 pixels height x 90 pixels wide. If the image is
# bigger, then it will be sized to fit into
# the space allotted.
logo_url: http://10.10.10.4/projects/phone/logo.bmp

#services_url - used to allow the user to access external
# XML applications that reside on a server.
services_url: "http://10.10.10.4/CiscoServices/Services.asp"

# End of Generic MGCP Default Config File.
```

How to Customize a Phone-Specific Configuration File

You can define parameters that are specific to a particular phone, such as the lines configured on a phone and the defined users for those lines, in a phone-specific configuration file.

**Note**

- If you configure a line to use an e-mail address, that line can be called only by using the e-mail address. Similarly, if you configure a line to use a number, that line can be called only by using the number. Each line can have a different proxy configured.
- Define the dial_template parameter in the default configuration file for maintenance and control purposes. Define the parameter in a phone-specific configuration file only if that phone needs to use a different dial plan than the one being used by the other phones in the same system.
- For a complete alphabetical list of configurable parameters, see Appendix B, “Configurable Parameters for the MGCP IP Phone.”

Procedure

Step 1 Obtain the phone-specific configuration file as follows:

- a. Go to the Cisco.com MGCP IP 7940/7960 phone software-download site at <http://www.cisco.com/cgi-bin/tablebuild.pl/mgcp-ip-phone7960>.
- b. Download the MGCP<mac-addr>.cnf file to the root directory of your TFTP server or to a subdirectory in which all phone-specific configuration files are stored.

- Step 2** Do the following for each phone that you plan to install:
- Using an ASCII editor, create and open an MGCP<mac-addr>.cnf file for the phone.
 - Modify parameters as needed.
 - Save the file to the root directory of your TFTP server or to a subdirectory that contains all the phone-specific configuration files. Name the file MGCP<mac-addr>.cnf. The MAC address must be in uppercase and the extension, cnf, must be in lowercase (for example, MGCP00503EFFF842.cnf).

Configuration Example

The following is an example of the phone-specific configuration file that you downloaded from Cisco.com:

```
# Generic Phone Specific Config File Options
#
The user config file options override any options specified in the Default Config File.
# :sample user config file name: MGC003E362FE92.cnf

# image_version - specifies which image version should
# be on the phone. This is used to upgrade from an
# MGCP image to a different MGCP image. The OS79XX.TXT
# file is only used to switch protocols (ie. SIP to MGCP).
image_version: P0M3-06-0-00

# tftp_cfg_dir - specifies the directory to use for the
# retrieving the MGC<MAC ADDR>.cnf file. The base
# for the directory is the base TFTP Server directory.
# tftp_cfg_dir is limited to 64 characters.
tftp_cfg_dir : ""

# phone_password - specifies the password used to Telnet
# to the phone. phone_password is limited to 32 characters.
# phone_prompt - specifies the prompt the phone will display
# when logged in from the console or Telnet session.
# phone_prompt is limited to 16 characters.
phone_password : "cisco"
phone_prompt : "MGCP Phone"

# sntp_mode - specifies the mode the SNTP server uses
# (unicast, multicast, anycast (default), directedbroadcast)
# sntp_server - specifies the address of the SNTP server
sntp_mode : anycast
sntp_server : "172.18.198.13"

# The following parameters setup time zone and
# daylight savings settings.
# Supported time zones are :
# EST, AST, NST, BST, AT, WAT, GMT, HST, YST
time_zone : EST
dst_offset : 1
dst_start_month : "April"
dst_start_day : 0
dst_start_day_of_week : "Sun"
dst_start_week_of_month : 1
dst_start_time : 2
dst_stop_month : "Oct"
dst_stop_day : 0
dst_stop_day_of_week : "Sun"
dst_stop_week_of_month : 8
```

```

dst_stop_time          : 2
dst_auto_adjust        : 1

# Date and Time format displays
# time_format_24hr (1 - yes, 0 - 12 hours format)
# date_format (M/D/Y, D/M/Y, Y/M/D, Y/D/M)
time_format_24hr : 1
date_format : M/D/Y

# MGCP Call Agent Information
# mgcp_gw_controller - address of call agent
# mgcp_input_port - port the phone listens on
# mgcp_output_port - port the call agent listens on
mgcp_gw_controller : 172.18.198.13
mgcp_input_port : 2427
mgcp_output_port : 2727

# mgcp_keepalive - specifies if the RSIP keepalive should
# be used to keep NAT bindings open to the Call Agent.
# values are [0 - off (default), 1 - on]
# mgcp_keepalive_timer - specifies the time interval to
# use for the mgcp keepalive timer if turned on.
# values are in seconds [10 to 600, 30 is default].
mgcp_keepalive: 0
mgcp_keepalive_timer: 30

# xml_card_dir - specifies the directory to use for the
# retrieving the xml cards file. The base
# for the directory is the base TFTP Server directory.
# xml_card_dir is limited to 64 characters.
# xml_card_file - specifies the file name of the XML Cards
# file. xml_card_file is limited to 20 characters.
xml_card_dir : ""
xml_card_file : "CARD.XML"

# tos_media - specifies the value to be used for the tos bits.
# valid range is 0-7.
tos_media: 7

#use_mac_name - specifies whether to use the IP address
# or MAC Address in the endpoint name. The default is
# to use the IP address. Valid values are :
# [ 0 - IP Address (default) 1 - Mac Address ]
use_mac_name: 0

#telnet_level - enables the ability to Telnet into phone
# and specify the level of access. The default is
# disabled. Valid values are:
# [ 0-disabled (default), 1-enabled, 2-privileged ]
telnet_level: 0

# End of Generic Phone Specific Config File.

```

How to Customize the Configuration from the Phone Menu

After the phone has been connected to power and initialized and the configuration files have been downloaded, you can modify your configuration using the phone menu.

This section contains the following procedures:

- Unlocking and Locking the Phone, page 3-11
- Setting and Restoring Network Parameters, page 3-12
- Setting and Restoring Phone-Specific Parameters, page 3-13
- Setting End-User Call Preferences, page 3-14

**Tip**

- To select a parameter, press the down arrow to scroll to and highlight the parameter, or press the number that represents the parameter (located to the left of the parameter on the LCD).
- During configuration, use * for dots (periods) or press the “.” soft key when available on the LCD.
- During configuration:
 - To enter a number, press the **Number** soft key. To enter a name, press the **Alpha** soft key.
 - To enter a new value, use the buttons on the dial pad.
If entering letters, use the numbers on the dial pad that are associated with a particular letter. For example, the 2 key has the letters A, B, and C. For a lowercase *a*, press the 2 key once. To scroll through the available letters and numbers, press the key repeatedly.
 - To delete any mistakes, press the << soft key.
 - To cancel all changes and exit a menu during configuration, press **Cancel**.
- After editing a parameter, press the **Validate** soft key to save the value that you have entered and exit the Edit panel.

Modifying your configuration using the phone menus requires that you unlock and relock the phone. A padlock icon in the upper-right corner of your LCD displays on the phone when the phone is locked. By default, the phone is locked.

**Note**

If the Network Configuration or MGCP Configuration menu is displayed, the lock icon in the upper-right corner of your LCD changes to an unlocked state. If you are located elsewhere in the Cisco IP 7960G/7940G phone menus, the next time you access the Network Configuration or MGCP Configuration menus, the unlocked icon displays, and you can modify the network and MGCP configuration settings.

Unlocking and Locking the Phone

You must unlock and relock the phone to modify a configuration using the phone menus. Similarly, phone users must unlock and relock the phone to modify end-user parameters.

A padlock icon in the upper-right corner of your LCD displays on the phone when the phone is locked. By default, the phone is locked.

Prerequisites

- Set the phone password with the phone_password parameter in the phone-specific configuration file.

Procedure

-
- Step 1** To unlock the phone, do the following:
- a. Press **Settings > Unlock Config**. The password prompt displays.
 - b. Enter a phone password. The phone unlocks, and the unlock icon displays on the LCD.



Note The Unlock Config menu choice changes to Lock Config and the configuration remains unlocked while you work within it. When you exit the configuration menu, the configuration automatically relocks.

- Step 2** To relock the phone, select **Lock Config** or **Exit**.
-

Setting and Restoring Network Parameters

You can modify network parameters using the phone menus.

**Note**

- TFTPServer may be a required parameter, depending on how you intend for the phone to locate the TFTP server from which it downloads its configuration file. You can provide the TFTP server IP address in either of two ways:
 - Provide it to the DHCP server. (For information, see the “Prerequisites” section on page 3-1.) Using normal Cisco Discovery Protocol (CDP) processes, the phone locates the DHCP server upon connection to the network; the server in turn provides the TFTP server address.
 - Provide it directly to the phone by means of the TFTPServer parameter as described in this procedure. If you use this method, first select **DHCP Enabled > No**.
 - For a complete alphabetical list of configurable parameters, see Appendix B, “Configurable Parameters for the MGCP IP Phone.”
-

Procedure

-
- Step 1** Unlock the phone (see the “Unlocking and Locking the Phone” section on page 3-11).
- Step 2** Select **Settings > Network Configuration**. The Network Configuration menu displays.
- Step 3** To set a parameter, select it and set it as desired.
- Step 4** To restore all parameters to their defaults, select **Erase Config > Yes**.



Note If DHCP is disabled on a phone, restoring default phone settings reenables DHCP.

- Step 5** Select **Save**. The phone programs the new information into flash memory and resets.
- Step 6** Relock the phone.
-

Setting and Restoring Phone-Specific Parameters

Phone users can modify the phone-specific configuration settings using the phone menus.

**Note**

- Parameters defined in the default configuration file override those specified in the phone-specific configuration file.
- If a phone-specific configuration file exists, the phone uses parameters entered locally until the next reboot.
- If you do not configure the phone using a TFTP server, you must configure the phone locally.
- To configure the preferred codec and out-of-band DTMF parameters, press **Change** until the option displays and then press **Save**.
- If your system has been set up to have the phones retrieve the configuration file from a TFTP server, you must use the server's configuration file to change the parameter value to a null value "" or to "UNPROVISIONED." The phone uses the setting for that variable that it has stored in flash memory.
- If the telnet_level parameter is set to allow privileged commands to be executed, the entire MGCP configuration can be erased. Use the **erase_profflash** command so that the phone can retrieve its configuration files.

Prerequisites

- Define the line parameters (those identified as linex) on the phone. If you configure a line to use an e-mail address, that line can be called only by using an e-mail address. Similarly, if you configure a line to use a number, that line can be called only by using the number.

Procedure

-
- Step 1** Unlock the phone (see the "Unlocking and Locking the Phone" section on page 3-11).
- Step 2** Select **Settings > MGCP Configuration**. The MGCP Configuration menu displays.
- Step 3** To set a required parameter, select it and set it as desired. The following are required parameters that you must set now if you did not set them in the default configuration file as described in the "How to Customize the Default Configuration File" section on page 3-5:
- CA IP address
 - Phone input port
 - Phone output port
- Step 4** To set an additional parameter, select it and set it as desired.
- Step 5** To restore a parameter to its default, do the following:
- a. One at a time, highlight the parameter whose setting you want to erase, and then select **Edit** followed by <<.
 - b. Select **Validate > Exit**.
 - c. If necessary, select **Back** to exit the menu.
- Step 6** Select **Save**. The phone programs the new information into flash memory and resets.
- Step 7** Relock the phone.
-

Setting End-User Call Preferences

End users can modify call preferences from their own phones, according to how you set the associated parameters.

Prerequisites

- Set configuration variables for call preferences as follows (see the “How to Customize a Phone-Specific Configuration File” section on page 3-8):
 - To enable end users to modify a preference, set to 0 or 1.
 - To prohibit end users from modifying a preference, set to 2 or 3.

Procedure

-
- Step 1** Unlock the phone (see the “Unlocking and Locking the Phone” section on page 3-11).
- Step 2** On the IP phone, select **Settings > Call Preferences**.
- Step 3** Set any of the preferences to the desired setting.
- Step 4** Select **Save**. The phone programs the new information into flash memory and resets.
- Step 5** Relock the phone.
-

How to Set the Date and Time

You can set date, time, and daylight savings time (DST) parameters. The current date and time is supported on the Cisco IP 7960G/7940G phone using Simple Network Time Protocol (SNTP) and is displayed on the LCD. DST and time-zone settings are also supported.

International time-zone abbreviations are supported and must be in all capital letters.



Note

We recommend that you set date- and time-related parameters in the default file for all phones. Alternatively, you can set the time-zone parameter manually on the phone or in the phone-specific configuration files.

Prerequisites

- Determine the type of DST that you want to configure:
 - Absolute DST (for example, starts on April 1 and ends on October 1)
 - Relative DST (for example, starts on the first Sunday in April and ends on the last Sunday of October)

Review the list of common and absolute DST parameters from Appendix B, “Configurable Parameters for the MGCP IP Phone.”

- Review the information on SNTP in Table 3-1 on page 3-16. SNTP parameters specify how the phone obtains the current time from an SNTP server.
- Determine your time zone from Table 3-2 on page 3-17.

Procedure

- Step 1** Using an ASCII text editor such as vi, open the MGCPDefault.cnf file.
- Step 2** Modify the following SNTP parameters as needed:
- sntp_mode
 - sntp_server
 - time_zone
- Step 3** Modify the following common DST parameters as needed:
- dst_offset
 - dst_auto_adjust
 - dst_start_month
 - dst_stop_month
 - dst_start_time
 - dst_stop_time
- Step 4** Do one of the following:
- Modify the following absolute DST parameters as needed:
 - dst_start_day
 - dst_stop_day
 - Modify the following relative DST parameters as needed:
 - dst_start_day_of_week
 - dst_start_week_of_month
 - dst_stop_day_of_week
 - dst_stop_week_of_month
- Step 5** Save the file to the root directory of your TFTP server.

**Note**

To adjust the phone display to European Day-Month-Year format, add the following entry to the MGCPDefault.cnf file: date_format:D/M/Y.

Table 3-1 describes the effects on SNTP mode when the SNTP server is null (not assigned an IP address) or when it is assigned a valid IP address.

Table 3-2 includes the time-zone information that you need to configure SNTP mode and server

Table 3-1 Effects on the SNTP Mode

SNTP Server	SNTP Mode			
	Unicast	Multicast	Any Cast ¹	Directed Broadcast
SNTP server parameter is null.				
Sends	No known server with which to communicate.	SNTP requests are not sent.	SNTP packet to the local network broadcast address. After the first SNTP response is received, the phone switches to unicast mode with the server being set as the one who first responded.	SNTP packet to the local network broadcast address. After the first SNTP response is received, the phone switches to multicast mode.
Receives	No known server with which to communicate.	Multicast data using the SNTP/NTP multicast address from the local network broadcast address from any server on the network.	Unicast SNTP data from the SNTP server that first responded to the network broadcast request.	SNTP data from the SNTP/NTP multicast address and the local network broadcast address from any server on the network.
SNTP server parameter is a valid IP address.				
Sends	SNTP request to the SNTP server.	SNTP requests are not sent.	If the mode is anycast and the SNTP server parameter is a valid IP address, the phone sends the request to the broadcast address in version 7.4.	SNTP packet to the SNTP server. After the first SNTP response is received, the phone switches to multicast mode.
Receives	SNTP response from the SNTP server and ignores responses from other SNTP servers.	SNTP data via the SNTP/NTP multicast address from the local network broadcast address.	SNTP response from the SNTP server and ignores responses from other SNTP servers.	SNTP data from the SNTP/NTP multicast address and the local network broadcast address and ignores responses from other SNTP servers.

1. If `sntp_mode` is set to anycast, the `sntp_server` address will be ignored and subsequent `sntp` requests will be sent to the first `sntp` server that responded (the first `sntp` request must be unconditionally sent to the broadcast address).

parameters.

Table 3-2 Time-Zone Information

Abbreviation	GMT Offset	Cities	Time-Zone Names
IDL	GMT-12:00	Eniwetok	IDL (International Date Line), IDLW (International Date Line West)
NT	GMT-11:00	Midway	BT (Bering Time), NT (Nome Time)
AHST	GMT-10:00	Hawaii	AHST (Alaska-Hawaii Standard Time), HST (Hawaiian Standard Time), CAT (Central Alaska Time)
IMT	GMT-09:30	Isle Marquises	Isle Marquises
YST	GMT-09:00	Yukon	YST (Yukon Standard Time)
PST	GMT-08:00	Los Angeles	PST (Pacific Standard Time)
MST	GMT-07:00	Phoenix	MST (Mountain Standard Time), PDT (Pacific Daylight Time)
CST	GMT-06:00	Dallas, Mexico City	CST (Central Standard Time), MDT (Mountain Daylight Time), Chicago
EST	GMT-05:00	New York	EST (Eastern Standard Time), CDT (Central Daylight Time), NYC
AST	GMT-04:00	La Paz	AST (Atlantic Standard Time), EDT (Eastern Daylight Time)
NST	GMT-03:30	Newfoundland	NST (Newfoundland Standard Time)
BST	GMT-03:00	Buenos Aires	BST (Brazil Standard Time), ADT (Atlantic Daylight Time), GST (Greenland Standard Time)
AT	GMT-02:00	Mid-Atlantic	AT (Azores Time)
WAT	GMT-01:00	Azores	WAT (West Africa Time)
GMT	GMT 00:00	London	GMT (Greenwich Mean Time), WET (Western European Time), UT (Universal Time)
CET	GMT+01:00	Paris	CET (Central European Time), MET (Middle European Time), BST (British Summer Time), MEWT (Middle European Winter Time), SWT (Swedish Winter Time), FWT (French Winter Time)
EET	GMT+02:00	Athens, Rome	EET (Eastern European Time), USSR-zone1, MEST (Middle European Summer Time), FST (French Summer Time)
BT	GMT+03:00	Baghdad, Moscow	BT (Baghdad Time), USSR-zone2
IT	GMT+03:30	Tehran	IT (Iran Time)

Table 3-2 Time-Zone Information (continued)

Abbreviation	GMT Offset	Cities	Time-Zone Names
ZP4	GMT+04:00	Abu Dhabi	USSR-zone3, ZP4 (GMT Plus 4 Hours)
AFG	GMT+04:30	Kabul	Afghanistan
ZP5	GMT+05:00	Islamabad	USSR-zone4, ZP5 (GMT Plus 5 Hours)
IST	GMT+05:30	Bombay, Delhi	IST (Indian Standard Time)
ZP6	GMT+06:00	Colombo	USSR-zone5, ZP6 (GMT Plus 6 Hours)
SUM	GMT+06:30	North Sumatra	NST (North Sumatra Time)
WAST	GMT+07:00	Bangkok, Hanoi	SST (South Sumatra Time), USSR-zone6, WAST (West Australian Standard Time)
HST	GMT+08:00	Beijing, Hong Kong	CCT (China Coast Time), HST (Hong Kong Standard Time), USSR-zone7, WADT (West Australian Daylight Time)
JST	GMT+09:00	Tokyo, Seoul	JST (Japan Standard Time/Tokyo), KST (Korean Standard Time), USSR-zone8
CAST	GMT+09:30	Darwin	SAST (South Australian Standard Time), CAST (Central Australian Standard Time)
EAST	GMT+10:00	Brisbane, Guam	GST (Guam Standard Time), USSR-zone9, EAST (East Australian Standard Time)
EADT	GMT+11:00	Solomon Islands	USSR-zone10, EADT (East Australian Daylight Time)
NZST	GMT+12:00	Auckland	NZT (New Zealand Time/Auckland), NZST (New Zealand Standard Time), IDLE (International Date Line East)

Time-Zone Configuration Examples

Absolute DST Configuration

The following is an example of an absolute DST configuration:

```
time_zone : PST
dst_offset : 01/00
dst_start_month : April
dst_start_day : 1
dst_start_time : 02/00
dst_stop_month : October
dst_stop_day : 1
dst_stop_time : 02/00
dst_stop_autoadjust : 1
```

Relative DST Configuration

The following is an example of a relative DST configuration:

```
time_zone : PST
dst_offset : 01/00
dst_start_month : April
dst_start_day : 0
dst_start_day_of_week : Sunday
dst_start_week_of_month : 1
dst_start_time : 02/00
dst_stop_month : October
dst_stop_day : 0
dst_stop_day_of_week : Sunday
dst_stop_week_of_month : 8
dst_stop_time : 02/00
dst_stop_autoadjust : 1
```

How to Verify Initialization

The initialization process establishes network connectivity and makes the phone operational in your IP network.

Procedure

-
- Step 1** After the phone has power connected to it, ensure that the phone cycles through the following steps. The following flash on and off in sequence: Headset button, Mute button, and Speaker button.
- Step 2** The Cisco Systems, Inc. copyright appears on the LCD.
- Step 3** The following messages appear:
- Configuring VLAN—The phone configures the Ethernet connection.
 - Configuring IP—The phone contacts the DHCP server to obtain network parameters and the IP address of the TFTP server.
 - Requesting Configuration—The phone contacts the TFTP server to request its configuration files and compares firmware images.
 - Upgrading Software—The phone displays this message only if it determines that an image upgrade is required. After upgrading the image, the phone automatically reboots to run the new image.
- Step 4** The main LCD displays the following:
- Primary directory number
 - Soft keys

If the phone successfully cycles through these steps, it has started up properly.

Where to Go Next

- See Chapter 4, “Managing Cisco MGCP IP Phones,” for information on upgrading firmware and performing other management tasks.
- See Chapter 5, “Monitoring Cisco MGCP IP Phones,” for information on debugging and on viewing network statistics.



Managing Cisco MGCP IP Phones

This chapter provides information on the following:

- How to Customize Cisco IP 7960G/7940G Phone Rings, page 4-1
- How to Access XML Cards, page 4-2
- How to View Your Cisco MGCP IP Phone Firmware Image Version, page 4-2
- How to Upgrade Your Cisco MGCP IP Phone Firmware Image, page 4-3
- How to Upgrade Your Cisco MGCP IP Phone Firmware Image and Reboot Remotely, page 4-6
- Where to Go Next, page 4-7

How to Customize Cisco IP 7960G/7940G Phone Rings

The Cisco IP 7960G/7940G phone ships with two ring types: Chirp1 and Chirp2. However, you can create and add custom rings.

Procedure

-
- Step 1** Create a pulse-code-modulation (PCM) file for each desired ring type and store it in the root directory of your TFTP server.
- PCM files must contain no header information and must comply with the following format guidelines:
- 8000-Hz sampling rate
 - 8 bits per sample
 - mu-law compression
- Step 2** Using an ASCII text editor such as vi, open the RINGLIST.DAT file. For each ring type that you are adding, specify the name as you want it to appear on the Ring Type menu, press **Tab**, and then specify the filename of the ring type. Your RINGLIST.DAT file should appear similar to the following:
- ```
Ring Type 1 ringer1.pcm
Ring Type 2 ringer2.pcm
```
- Step 3** Save and close the file.
-

## How to Access XML Cards

You can access XML cards in any of the following ways:

- Select **Services** (configured by means of the `services_url` parameter).
- Select **External Directory** (configured by means of the `directory_url` parameter).
- Download a bitmap to be used as the phone logo (configured by means of the `logo_url` parameter).

For more information about using XML on your Cisco MGCP IP phone, refer to the following:

- IP Telephony  
<http://www.hotdispatch.com/cisco-ip-telephony>
- Cisco CallManager Services Developer Kit  
[http://www.cisco.com/pcgi-bin/dev\\_support/access\\_level/product\\_support](http://www.cisco.com/pcgi-bin/dev_support/access_level/product_support)
- *Developing Cisco IP Phone Services* by Darrick Deel, Mark Nelson, and Anne Smith, ISBN 1-58705-060-9

## How to View Your Cisco MGCP IP Phone Firmware Image Version

You can determine your firmware image version.

### Procedure

---

- Step 1** Select **Settings > Status**.
- Step 2** Select **Firmware Versions**. The Firmware Versions menu appears.
- Step 3** View information as needed. The following displays:
- Application Load ID—Current software image on the phone.
  - Boot Load ID—Bootstrap loader image version that is manufactured on the phone. This image name does not change.
  - DSP Load ID—Current DSP version on the phone.
- Step 4** Select **Exit**.
-

# How to Upgrade Your Cisco MGCP IP Phone Firmware Image

**Note**

Refer to the *Cisco 7940 and 7960 IP Phones Firmware Upgrade Matrix* for additional upgrade information for all releases.

At some point after you install hardware and the initial firmware image, you could require an upgrade. You can upgrade by means of either of two methods:

- You can upgrade one phone at a time using a phone-defined configuration file.
- You can upgrade a system of phones using the default configuration file.

You can upgrade to Release 6.0 or 6.1 from any earlier release. The path to do so is as follows:

-- > Release 2.3 --> Release 5.3 --> Release 7.4

Each intermediate releases adds key functionality that is necessary for a subsequent upgrade. Each upgrade provides the following:

- Prevents digital signal processor (DSP) mismatches in the upgrade to a higher release.
- Addresses user-interface responsiveness and voice-clipping issues.
- Adds image authentication to IP phone protocols, so that tampering with the binary image before the image is downloaded to the phone is not allowed. Any tampering with the image causes the phone to fail the authentication process and reject the image.

It is possible during the upgrade procedure to configure your system to enable the phone to dual-boot from MGCP. If it is so configured, during initialization the phone automatically determines the network in which it is being installed.

## Procedure

- 
- Step 1** Determine your current firmware image release. (For instructions, see the “How to View Your Cisco MGCP IP Phone Firmware Image Version” section on page 4-2.)
- Step 2** To enable dual-booting, use an ASCII text editor such as vi, open the OS79XX.TXT dual-boot file that resides in the root directory of your TFTP server, and add the following:
- ```
P0M3-03-0-00
```
- Step 3** If your current release is earlier than Release 2.3, upgrade to Release 2.3 as follows:
- a. From the Cisco.com website, do the following:
 1. Go to the Cisco.com MGCP IP 7940/7960 phone software-download site at <http://www.cisco.com/cgi-bin/tablebuild.pl/mgcp-ip-phone7960>.
 2. Download the following to the root directory of your TFTP server: Release 2.3 ZIP archive, default configuration file, and release notes.
 - b. Read the release notes and any readme.txt files. Unzip the archive and extract the binary image files to the root directory of the TFTP server.
 - c. Using an ASCII text editor such as vi, do the following:
 1. Open the default configuration file.
 2. Update the image version specified in the image_version variable. The version name in the image_version variable should match the version name (without the .sbn or .bin extension) of the latest firmware image; in this case the version is P0M30203.

3. Save the modified file to the TFTP server.
- d. Reinitialize each phone and verify that it does the following:
 1. Contacts the TFTP server and requests its configuration files.
 2. Compares the image defined in the file to the image that it has stored in flash memory.
 3. If the images differ, downloads the image defined in the configuration file (which is stored in the root directory on the TFTP server).
 4. Programs that image into flash memory.
 5. Reboots.

Step 4 If your current release is between Release 2.3 and Release 5.2, upgrade to Release 5.3 as follows:



Note If your current release is Release 5.2, you need not upgrade to Release 5.3. Upgrade directly to Release 6.0 or 6.1 as described in Step 5 below.

- a. From the Cisco.com website listed in Step 3a above, download the following to the root directory of your TFTP server: Release 5.3 ZIP archive, default configuration file, and release notes.
- b. Read the release notes and any readme.txt files. Unzip the archive and extract the binary image files to the root directory of the TFTP server.
- c. Using an ASCII text editor such as vi, do the following:
 1. Open the configuration file.
 2. Update the image version specified in the image_version variable. The version name in the image_version variable should match the version name (without the .sbn or .bin extension) of the latest firmware image.
 3. Save the modified file to the TFTP server.
- d. Reinitialize each phone as described in Step 3d above.

Step 5 If your current release is Release 5.2 or higher, upgrade to Release 6.0 or 6.1 as follows:

- a. From the Cisco.com website listed in Step 3a above, download the following to the root directory of your TFTP server: Release 6.0 (or 6.1) ZIP archive, default configuration file, and release notes.
- b. Read the release notes and any readme.txt files. Unzip the archive and extract the binary image files to the root directory of the TFTP server.
- c. Using an ASCII text editor such as vi, do the following:
 1. Open the configuration file.
 2. Update the image version specified in the image_version variable. The version name in the image_version variable should match the version name (without the .sbn or .bin extension) of the latest firmware image.
 3. Save the modified file to the TFTP server.
- d. Reinitialize each phone as described in Step 3d above.

Step 6 If you are upgrading from any previous release to Release 7.0, 7.1, or a later release, see the “Upgrading to Versions 7.0 and Later Releases” section on page 4-5.

**Note**

If you do not define the `image_version` parameter in the default configuration file, only phones that have an updated phone-specific configuration file with the new image version and that have been restarted use the latest firmware image. All other phones use the older version until their configuration files have been updated with the new image version.

Upgrading to Versions 7.0 and Later Releases

**Note**

Refer to the *Cisco 7940 and 7960 IP Phones Firmware Upgrade Matrix* for additional upgrade information for all releases.

Releases 7.x is delivered in a ZIP archive. The ZIP archive contains 6 files:

- P003-07-0-00.bin—New universal loader application file
- P003-07-0-00.sbn—New universal loader application file
- P0M3-07-0-00.sb2—New MGCP 7.x release image.
- P0M3-07-0-00.loads—New loader file. The Universal Loader uses the P0M3-07-0-00.loads file to determine which images to put on the phone. This file specifies the Loader application version and the MGCP application version. The P0M3-07-0-00.sbn, P0M3-07-0-00.loads, P003-07-0-00.sb2 are all signed files and cannot be altered.
- OS79XX.TXT—Contains the upgrade image of the universal loader used by pre-release 7.0 images.

Procedure

- Step 1** Unzip the archive contents into your root TFTP directory.
- Step 2** Edit your `MGCPDefault.cnf` and/or `MGCP<mac addr>.cnf` file to have the correct image version. For example:
- ```
image_version: P0M3-07-0-00
```
- Step 3** Reboot the phone.
- The phone automatically upgrades to the Universal Loader application (P003-07-0-00) upon reboot. Once the Universal Loader application starts, it will examine the MGCP configuration file to determine which image to use (determined in Step 2 above).
- After determining the image version, the Universal Loader application examines the `.loads` file to determine if the `.loads` file needs to be upgraded to the MGCP.sb2 image (release 7.0 or 7.1). The upgrade will occur automatically, if needed. When upgrading is done, the release 7.0 or 7.1 image is initiated.

## Upgrading with New Features

This section contains information on how to add new features to the Cisco IP 7960G/7940G phone.

## MGCP NAT Support

In its simplest configuration, the Network Address Translator (NAT) operates on a router connecting two networks together; one of these networks (designated as inside) is addressed with either private or obsolete addresses that need to be converted into legal addresses before packets are forwarded onto the other network (designated as outside). The translation operates in conjunction with routing, so that NAT can simply be enabled on a customer-side Internet access router when translation is desired.

Use of a NAT device provides RFC 1631-style network address translation on the router platform. The goal of NAT is to provide functionality as if the private network had globally unique addresses and the NAT device was not present. RFC 1631 represents a subset of Cisco IOS NAT functionality.

Cisco IOS NAT supports “bi-directional translation” through the simultaneous use of “inside source” and “outside source” translations.

When NAT is enabled on the Cisco MGCP IP phone, MGCP messages are able to traverse NAT/firewall networks. The Session Description Protocol (SDP) message is modified to reflect the NAT parameters so that if NAT is enabled, the SDP message uses `nat_address` and a Realtime Transport Protocol (RTP) port between the `start_media_port` and the `end_media_port` range. The UDP port for MGCP messages can be configured using parameter `voip_control_port`.

### MGCP NAT Configuration Parameters

Use the following configuration parameters to add the NAT feature to your Cisco IP 7960G/7940G phone:

```
nat_enable 0 disabled(default); 1 enabled
If nat is enabled the SDP message uses nat_address and an RTP port between the start_media
port and the end_media_port range
nat_address IP address of the NAT or firewall server
voip_control_port UDP port used for MGCP messages when nat_enable = 1
```

# How to Upgrade Your Cisco MGCP IP Phone Firmware Image and Reboot Remotely

If you have an MGCP call agent and a TFTP server in your phone network, you can upgrade your system firmware image and reboot remotely.

### Procedure

- 
- Step 1** Edit the default configuration file as follows:
- Using an ASCII text editor such as `vi`, open the `MGCPDefault.cnf` file located in the root directory of your TFTP server.
  - Change the `image_version` parameter to Release 7.4.
  - Save and close the file.
- Step 2** Edit the synchronization file as follows:
- Using a text editor, open the `syncinfo.xml` file located in the root directory of your TFTP server.
  - Specify values for the image version and sync parameter as follows:

```
<IMAGE VERSION="image_version" SYNC="sync_number"/>
```

Where the variables are as follows:

- `image_version`—Image version of the phone. You can use the asterisk (\*) as a wildcard character.
- `sync_number`—Synchronization level of the phone. A valid value is a character string of up to 32 characters. Default is 1.

c. Save and close the file.

**Step 3** Send a notification request (RQNT) message to the phone to initiate a reboot. In the message, ensure that the signal line is equal to X-check-sync. The following is a sample RQNT message:

#### Sample RQNT Message

```
RQNT 9713 d001 @ 003094c25d40 MGCP 0.1
X: 100
S: X-check-sync
```

---

During a remote reboot, the phone does the following:

1. If it is idle, the phone waits 20 seconds and contacts the TFTP server for the `syncinfo.xml` file. Otherwise, it waits until it is idle for 20 seconds and then contacts the TFTP server.
2. The phone reads the `syncinfo.xml` file and does the following as appropriate:
  - a. Determines whether the current image is specified. If it is not specified, the phone proceeds to Step b. If it is specified, the phone proceeds to Step c.
  - b. Determines whether the image version parameter contains a wildcard entry (\*). If it does, the phone proceeds to Step c. If it does not, the phone proceeds to Step d.
  - c. Determines if the synchronization value is different from that stored on the phone. If it is, the phone proceeds to Step 3. If it is not, the phone proceeds to Step d.
  - d. Does nothing. The procedure is finished.
3. The phone performs a normal reboot.

During reboot, the phone sees the new image and upgrades to it with a synchronization value as specified in the `syncinfo.xml` file. The procedure is finished.

## Where to Go Next

- See Chapter 5, “Monitoring Cisco MGCP IP Phones,” for information on debugging and on viewing network statistics.

■ Where to Go Next



## Monitoring Cisco MGCP IP Phones

---

This chapter provides information on the following:

- How to Use the Command-Line Interface to Monitor Phones, page 5-1
- How to Use the Phone Menus to Access Status Information, page 5-7

### How to Use the Command-Line Interface to Monitor Phones

You can use Telnet or a console to connect to your Cisco IP 7960G/7940G phone, and you can use the command-line interface (CLI) to debug or troubleshoot the phone. Table 5-1 shows the available CLI commands and their syntax.



**Note**

- You need the phone IP address to use the CLI in a Telnet session. To get the IP address, select **Settings > Network Configuration > IP Address**. The default Telnet password is “cisco.”
- You can conduct only two Telnet sessions at any time.
- The phone cannot originate a Telnet session to another address.

Table 5-1 describes the available commands.

Table 5-1 CLI Commands

Command	Purpose
MGCP Phone> <b>clear</b> { <b>arp</b>   <b>ethernet</b>   <b>ip</b>   <b>malloc</b>   <b>mwi</b>   <b>tcp-stats</b> }	Clears the following, depending on the keywords used: <ul style="list-style-type: none"> <li>• <b>arp</b>—Address Resolution Protocol (ARP) cache.</li> <li>• <b>ethernet</b>—Network statistics.</li> <li>• <b>ip</b>—IP statistics.</li> <li>• <b>malloc</b>—Memory allocation.</li> <li>• <b>mwi</b>—Message-waiting indicator.</li> <li>• <b>tcp-stats</b>—TCP statistics.</li> </ul>
MGCP Phone> <b>debug</b> { <b>arp</b>   <b>console-stall</b>   <b>strlib</b>   <b>malloc</b>   <b>malloctable</b>   <b>sk-platform</b>   <b>flash</b>   <b>dsp</b>   <b>vcm</b>   <b>dtmf</b>   <b>task-socket</b>   <b>mgcpio</b>   <b>mgcp_parse</b>   <b>dns</b>   <b>config</b>   <b>sntp</b>   <b>sntp-packet</b> }	Shows detailed debug output for the following, depending on the keywords used: <ul style="list-style-type: none"> <li>• <b>arp</b>—ARP cache.</li> <li>• <b>console-stall</b>—Console-stall driver output mode.</li> <li>• <b>strlib</b>—String library.</li> <li>• <b>malloc</b>—Memory allocation.</li> <li>• <b>malloctable</b>—Memory allocation table. The table can be viewed with the <b>show malloctable</b> command.</li> <li>• <b>sk-platform</b>—The platform.</li> <li>• <b>flash</b>—Flash memory information.</li> <li>• <b>dsp</b>—Digital signal processor (DSP) accesses.</li> <li>• <b>vcm</b>—Voice Channel Manager (VCM), including tones, ringing, and volume.</li> <li>• <b>dtmf</b>—Dual-tone multifrequency (DTMF) relay.</li> <li>• <b>task-socket</b>—Socket task.</li> <li>• <b>mgcpio</b>—MGCP input and output.</li> <li>• <b>mgcp_parse</b>—Detailed MGCP output; displays each MGCP message as it is parsed or built.</li> <li>• <b>dns</b>—DNS command-line interface (CLI) configuration; allows you to clear the cache and set servers.</li> <li>• <b>config</b>—Output for the <b>config system</b> command.</li> <li>• <b>sntp</b>—Simple Network Time Protocol (SNTP).</li> <li>• <b>sntp-packet</b>—Full SNTP packet data.</li> </ul> <p><b>Note</b> Do not use the <b>debug all</b> command because it can cause the phone to become inoperable. This command is for use only by Cisco TAC personnel.</p> <p><b>Note</b> To turn the debugging off, use the <b>undebug</b> command (works just as does the <b>no debug</b> command).</p>

Table 5-1 CLI Commands (continued)

Command	Purpose
MGCP Phone> <b>dns</b> <i>{-p   -c   -s ip-address   -b ip-address}</i>	<p>Manipulates the DNS system. Keywords and arguments are as follows:</p> <ul style="list-style-type: none"> <li>• <b>-p</b>—Prints the DNS cache table.</li> <li>• <b>-c</b>—Clears the DNS cache table.</li> <li>• <b>-s ip-address</b>—Sets the primary DNS server.</li> <li>• <b>-b ip-address</b>—Sets the first backup server.</li> </ul>
MGCP Phone> <b>erase protflash</b>	Erases the protocol area of flash memory. Forces the phone to reset its IP stack and request its configuration files again. This command can be used only if the <code>telnet_level</code> parameter is set to allow privileged commands to be executed.
MGCP Phone> <b>exit</b>	Exits the Telnet or console session.
MGCP Phone> <b>ping</b> <i>ip-address number packet-size timeout</i>	<p>Sends an Internet Control Message Protocol (ICMP) ping to a network address. Arguments are as follows:</p> <ul style="list-style-type: none"> <li>• <i>ip-address</i>—Dotted IP address or alphanumeric address (host name) to ping.</li> <li>• <i>number</i>—Number of pings to send; default is 5.</li> <li>• <i>packet-size</i>—Size of the packet, in bytes. Range is 1 to 1480. Default is 100.</li> <li>• <i>timeout</i>—Time, in seconds, to wait before a request times out. Default is 2.</li> </ul>
MGCP Phone> <b>reset</b>	Resets the phone line. This command can be used only if the <code>telnet_level</code> parameter is set to allow privileged commands to be executed.
MGCP Phone> <b>show</b> <i>{arp   debug   ethernet   ip   strpool   memorymap   dump   mallocable   stacks   status   abort_vector   flash   dspstate   rtp   tcp   network   config   mgcp_lists   personaldir   dialplan   timers}</i>	<p>Shows information about the MGCP IP phone, depending on the keywords used:</p> <ul style="list-style-type: none"> <li>• <b>arp</b>—Contents of the ARP cache.</li> <li>• <b>debug</b>—Which debug modes are activated.</li> <li>• <b>ethernet</b>—Network statistics.</li> <li>• <b>ip</b>—IP packet statistics.</li> <li>• <b>strpool</b>—String library pool of strings. This command can be used only if the <code>telnet_level</code> parameter is set to allow privileged commands to be executed.</li> </ul>

Table 5-1 CLI Commands (continued)

Command	Purpose
show command keywords (continued)	<ul style="list-style-type: none"> <li>• <b>memorymap</b>—Memory mapping table, including free, used, and wasted blocks.</li> <li>• <b>dump</b>—Dump of the memory contents. This command can be used only if the telnet_level parameter is set to allow privileged commands to be executed.</li> <li>• <b>malloctable</b>—Memory allocation table.</li> <li>• <b>stacks</b>—Tasks and buffer lists.</li> <li>• <b>status</b>—Current phone status, including errors.</li> <li>• <b>abort_vector</b>—Address of the last recorded abort vector.</li> <li>• <b>flash</b>—Flash memory information.</li> <li>• <b>dspstate</b>—DSP status, including whether the DSP is ready, the audio mode, whether keepalive pending is turned on, and the ringer state.</li> <li>• <b>rtp</b>—Packet statistics for the RTP streams.</li> <li>• <b>tcp</b>—Status of TCP ports, including the state (listen or closed) and the port number.</li> <li>• <b>network</b>—Network information, such as phone platform, DHCP server, phone IP address and subnet mask, default gateway, address of the TFTP server, phone MAC address, domain name, and phone name.</li> <li>• <b>config</b>—Current flash configuration, including network information, phone label and password, SNTP server address, DST information, time and date format, and input and output port numbers.</li> <li>• <b>mgcp_lists</b>—Filter list and duplicate message list lengths.</li> <li>• <b>personaldir</b>—Current contents of the personal directory. This command can be used only if the telnet_level parameter is set to allow privileged commands to be executed.</li> <li>• <b>dialplan</b>—Phone dial plan.</li> <li>• <b>timers</b>—Current status of the platform timers.</li> </ul>

Table 5-1 CLI Commands (continued)

Command	Purpose
MGCP Phone> <b>test</b> { <b>open</b>   <b>close</b>   <b>key</b> { <i>k1</i> ... <i>k12</i> }   <b>onhook</b>   <b>offhook</b>   <b>show</b>   <b>hide</b> }	<p data-bbox="833 315 1521 472">Accesses the remote call test interface, allowing you to control the phone from a remote site. You can use this command only if the <code>telnet_level</code> parameter is set to allow privileged commands to be executed. Keywords are as follows:</p> <ul style="list-style-type: none"> <li data-bbox="846 489 1414 520">• <b>open</b>—Enables the use of the test functionality.</li> <li data-bbox="846 533 1414 564">• <b>close</b>—Disables the use of the test functionality.</li> <li data-bbox="846 577 1502 640">• <b>key</b>—Simulates key presses. The arguments <i>k1</i> through <i>k12</i> are as follows:               <ul style="list-style-type: none"> <li data-bbox="891 653 1227 684">– <i>k1</i>—<code>voldn</code>—Volume down</li> <li data-bbox="891 697 1195 728">– <i>k2</i>—<code>volup</code>—Volume up</li> <li data-bbox="891 741 1187 772">– <i>k3</i>—<code>headset</code>—Headset</li> <li data-bbox="891 785 1149 816">– <i>k4</i>—<code>spkr</code>—Speaker</li> <li data-bbox="891 829 1125 861">– <i>k5</i>—<code>mute</code>—Mute</li> <li data-bbox="891 873 1101 905">– <i>k6</i>—<code>info</code>—Info</li> <li data-bbox="891 917 1175 949">– <i>k7</i>—<code>msgs</code>—Messages</li> <li data-bbox="891 961 1153 993">– <i>k8</i>—<code>serv</code>—Services</li> <li data-bbox="891 1005 1167 1037">– <i>k9</i>—<code>dir</code>—Directories</li> <li data-bbox="891 1050 1146 1081">– <i>k10</i>—<code>set</code>—Settings</li> <li data-bbox="891 1094 1227 1125">– <i>k11</i>—<code>navup</code>—Navigate up</li> <li data-bbox="891 1138 1260 1169">– <i>k12</i>—<code>navdn</code>—Navigate down</li> </ul> </li> </ul> <p data-bbox="878 1192 1479 1287">The keys 0 through 9, #, and * may be entered in continuous strings to better express typical dialing strings. A typical command would be <b>test key 23234</b>.</p> <ul style="list-style-type: none"> <li data-bbox="846 1304 1390 1335">• <b>onhook</b>—Simulates a handset on-hook event.</li> <li data-bbox="846 1348 1398 1379">• <b>offhook</b>—Simulates a handset off-hook event.</li> <li data-bbox="846 1392 1203 1423">• <b>show</b>—Shows test feedback.</li> <li data-bbox="846 1436 1187 1467">• <b>hide</b>—Hides test feedback.</li> </ul>

Table 5-1 CLI Commands (continued)

Command	Purpose
MGCP Phone> <b>traceroute</b> <i>ip-address</i> [ <i>tll</i> ]	<p>Initiates a traceroute session from the console or from a Telnet session. Traceroute shows the route that IP datagrams follow from the MGCP IP phone to the specified IP address. The arguments are as follows:</p> <ul style="list-style-type: none"> <li>• <i>ip-address</i>—The dotted IP address or alphanumeric address (host name) of the host to which you are sending the traceroute.</li> <li>• <i>tll</i>—(Optional) The time-to-live value or the number of routers (hops) through which the datagram can pass. The default value is 30.</li> </ul>
MGCP Phone> <b>tty</b> { <b>echo</b> { <b>on</b>   <b>off</b> }   <b>mon</b>   <b>timeout</b> <i>value</i>   <b>kill</b> <i>session</i>   <b>msg</b> }	<p>Controls the Telnet system. The arguments and keywords are as follows:</p> <ul style="list-style-type: none"> <li>• <b>echo</b>—Controls local echo. <ul style="list-style-type: none"> <li>– <b>on</b>—Turns the echo on.</li> <li>– <b>off</b>—Turns the echo off.</li> </ul> </li> <li>• <b>mon</b>—Sends all debug output to both the console and the Telnet sessions.</li> <li>• <b>timeout</b> <i>value</i>—Sets the Telnet session timeout period, in seconds. The <i>value</i> range is from 0 to 65535.</li> <li>• <b>kill</b> <i>session</i>—Tears down the Telnet session specified by the <i>session</i> argument.</li> <li>• <b>msg</b>—Sends a message to another terminal logged into the phone; for example, you can send a message telling everyone else that is logged in to log off.</li> </ul>

## Output Examples

### Ethernet Statistics

The following sample output shows Ethernet statistics:

```
MGCP Phone> show ethernet
```

```
Ethernet Mib:
```

```

ResErr 00000154, RcvCnt 00137436, RcvErr 00000000, DrpCnt 00001421
BrdCst 00122041, TooLng 00000363, TxCnt 00012322, TxQCnt 00000000
TxQue 00000000, TxQMax 00000000, TxXC01 00000000, TxFram 00012322
```

```
Overflow Counters...
```

```
UDP 00000000, ICMP 00000000, NonIP 00000000, TCP 00000000
CDP 00000000, Unknown 00000000, Arp 00000000
```

### IP Statistics

The following sample output shows IP statistics:

```
MGCP Phone> show ip
```

```
IP Statistics:
```

```

Received 01426183, RxDrops 00002181
RxFrags 00000000, RxFragDrops 00000000, RxReassembled 00000000
Transmitted 00011996, TxDrops 00000010, TxFragments 00000000
```

## How to Use the Phone Menus to Access Status Information

There are several types of status information that you can access using the Settings button. The information that you can obtain can aid in system management. This section contains the following subsections:

- Viewing Status Messages, page 5-7
- Viewing Network Statistics, page 5-7

### Viewing Status Messages

You can view status messages that you can use to diagnose network problems.

#### Procedure

- 
- Step 1** Select **Settings > Status > Status Messages**. The Status Messages menu displays.
- Step 2** View information as needed.
- Step 3** Select **Exit**.
- 

### Viewing Network Statistics

You can view statistical information about the phone and network performance.

#### Procedure

- 
- Step 1** Select **Settings > Status > Network Statistics**. The Network Statistics menu displays.
- Step 2** View the following information as needed:
- Rcv—Number of packets received by the phone, not through the switch.
  - Xmit—Number of packets sent by the phone, not through the switch.
  - REr—Number of packets received by the phone that contained errors.
  - BCast—Number of broadcast packets received by the phone.

- Phone State Message—TCP messages indicating the state of the phone. Possible messages are as follows:
  - Phone Initialized—TCP connection has not gone down since the phone was powered on.
  - Phone Closed TCP—TCP connection was closed by the phone.
  - TCP Timeout—TCP connection was closed because of a retry timeout.
  - Error Code—Error messages that indicate unusual reasons for which the TCP connection was closed.
- Elapsed Time—Length of time (in days, hours, minutes, and seconds) since the last power cycle.
- Port 0 Full, 100—Indicates that the network is in a linked state and has autonegotiated a full-duplex 100-Mbps connection.
- Port 0 Half, 100—Indicates that the network is in a linked state and has autonegotiated a half-duplex 100-Mbps connection.
- Port 0 Full, 10—Indicates that the network is in a linked state and has autonegotiated a full-duplex 10-Mbps connection.
- Port 0 Half, 10—Indicates that the network is in a linked state and has autonegotiated a half-duplex 10-Mbps connection.
- Port 1 Full, 100—Indicates that the network is in a linked state and has autonegotiated a full-duplex 100-Mbps connection.
- Port 1 Half, 100—Indicates that the network is in a linked state and has autonegotiated a half-duplex 100-Mbps connection.
- Port 1 Full, 10—Indicates that the network is in a linked state and has autonegotiated a full-duplex 10-Mbps connection.
- Port 1 Half, 10—Indicates that the network is in a linked state and has autonegotiated a half-duplex 10-Mbps connection.
- ethernet—Indicates the status of the Ethernet connection.

**Step 3** Select **Exit**.



---

**Note** To reset the values, power the phone off and on.

---



# Technical Specifications of the Cisco IP 7960G/7940G Phone

This appendix contains the following sections:

- Physical and Operating Environment Specifications, page A-1
- Cable Specifications, page A-2
- Regulatory Safety Compliance, page A-2
- Connection Specifications, page A-2

## Physical and Operating Environment Specifications

Table A-1 lists the physical and operating specifications of the Cisco IP 7960G/7940G phone.

**Table A-1 Cisco IP 7960G/7940G Phone Specifications**

Specification	Value or Range
Operating temperature	32 to 104°F (0 to 40°C).
Operating relative humidity	10 to 95% (noncondensing).
Storage temperature	14 to 140°F (–10 to 60°C).
Height	8 in. (20.32 cm).
Width	10.5 in. (26.67 cm).
Depth	6 in. (15.24 cm).
Weight	3.5 lb (1.6 kg).
Power	100 to 240 VAC, 50 to 60 Hz, 0.5 A—when using the AC adapter. 48 VDC, 0.2 A—when using the inline power over the network cable.
Cables	Two pair of Category 3 cables for 10 Mbps. Two pair of Category 5 cables for 100 Mbps.
Distance requirements	As supported by the Ethernet specification, it is assumed that most phones that are deployed in the field are within 330 ft (100 m) of a phone closet.

## Cable Specifications

The following cables are required to connect the Cisco IP 7960G/7940G phone:

- RJ-11 for the handset connection.
- RJ-45 jack for the LAN connection (labeled “10/100 SW”).
- RJ-45 jack for a second 10BASE-T compliant connection (labeled “10/100 PC”).
- 48-volt power connector. The diameter of the center pin in the phone power jack (Switchcraft 712A) is 0.1 inches (2.5 mm). The center pin is positive (+) voltage. The miniature power plug required to mate with the power jack on the phone is a Switchcraft 760 or equivalent.

## Regulatory Safety Compliance

For international agency compliance, safety, and statutory information on Cisco IP phone models in the 7900 series, refer to *Regulatory Compliance and Safety Information for the Cisco IP Phone 7900 Series* at [http://www.cisco.com/univercd/cc/td/doc/product/voice/c\\_ipphon/english/ipp7960/iphrcsi3.htm](http://www.cisco.com/univercd/cc/td/doc/product/voice/c_ipphon/english/ipp7960/iphrcsi3.htm).

## Connection Specifications

The Cisco IP 7960G/7940G phone has two RJ-45 ports that each support 10/100 Mbps half- or full-duplex connections to external devices—the network port and the access port. You can use either Category 3 or Category 5 cabling for 10-Mbps connections, but use Category 5 for 100-Mbps connections. On both the LAN-to-phone port (left RJ-45 port facing the back of the phone) and the PC-to-phone port (right port), use full-duplex to avoid collisions. Use the LAN-to-phone port to connect the phone to the network. Use the PC-to-phone port to connect a network device, such as a computer, to the phone.

For a diagram that identifies the different ports on the back of the phone, see the “Cisco IP 7960G/7940G Phone Overview” section on page 1-2.



## Configurable Parameters for the MGCP IP Phone

This appendix describes configurable MGCP parameters (see Table B-1). Parameters are in alphabetical order. Optional parameters are so noted.

**Table B-1** Parameters in the Default Configuration File

MGCP Parameter	Description
date_format	(Optional) Format for dates. Valid values are the following: <ul style="list-style-type: none"><li>• M/D/Y—Month/day/year</li><li>• D/M/Y—Day/month/year</li><li>• Y/M/D—Year/month/day</li><li>• Y/D/M—Year/day/month</li><li>• Y-M-D—Year-month-day</li><li>• YY-M-D—4-digit year-month-day</li></ul> Default is M/D/Y.
dial_template	Template with which you can specify which file to download for your dial plan.
directory_url	(Optional) URL of the external directory server. This URL is accessed when the Directory key is pressed and the External Directory option is selected. For example, use directory_url <a href="http://10.10.10.10/CiscoServices/Directory.asp">http://10.10.10.10/CiscoServices/Directory.asp</a> .
dst_auto_adjust	(Optional) Date, time, and whether to use Daylight Saving Time (DST). Automatically adjusts for DST on the phones. Valid values are 0 (disable automatic adjustment) and 1 (enable automatic adjustment). Default is 1.

**Table B-1 Parameters in the Default Configuration File (continued)**

MGCP Parameter	Description
dst_offset	Offset from the phone time when DST is in effect. When DST is not in effect, the specified offset is no longer applied to the phone time. Valid values are the following: <ul style="list-style-type: none"> <li>hour/minute</li> <li>-hour/minute</li> <li>+hour/minute</li> <li>hour</li> <li>-hour</li> <li>+hour</li> </ul>
dst_start_day	(Optional) Day of the month on which DST begins. Valid values are the following: <ul style="list-style-type: none"> <li>1 to 31 (for days of the month)</li> <li>0 (ignore this field and use the value in the dst_start_day_of_week parameter instead)</li> <li>Default is 0.</li> </ul>
dst_start_day_of_week	(Optional) Day of the week on which DST begins. Valid values are as follows: <ul style="list-style-type: none"> <li>Any of the following: Sunday or Sun, Monday or Mon, Tuesday or Tue, Wednesday or Wed, Thursday or Thu, Friday or Fri, Saturday or Sat, Sunday or Sun</li> <li>1 to 7 (1 is Sunday; 7 is Saturday)</li> </ul> Name of the day is not case-sensitive. In the United States, the default is Sunday.
dst_start_month	(Optional) Month in which DST starts. Valid values are January, February, March, April, May, June, July, August, September, October, November, and December or 1 through 12 with 1 being January and 12 being December. Name of the month is not case-sensitive. In the United States, the default is April.
dst_start_time	(Optional) Time of day on which DST begins. Valid values are hour/minute (02/00) and hour:minute (02:00). In the United States, the default is 02:00.
dst_start_week_of_month	(Optional) Week of month in which DST begins. Valid values are 1 to 6 and 8 (1 is the first week; each subsequent number is a subsequent week; 8 is the last week in the month regardless of which week the last week is). In the United States, the default is 1.
dst_stop_day	(Optional) Day of the month on which DST ends. Valid values are as follows: <ul style="list-style-type: none"> <li>1 to 31 (for the days of the month)</li> <li>0 (ignore this field and use the value in the dst_stop_day_of_week parameter instead)</li> </ul> Default is 0.

**Table B-1 Parameters in the Default Configuration File (continued)**

<b>MGCP Parameter</b>	<b>Description</b>
dst_stop_day_of_week	<p>(Optional) Day of the week on which DST ends. Valid values are as follows:</p> <ul style="list-style-type: none"> <li>Any of the following: Sunday or Sun, Monday or Mon, Tuesday or Tue, Wednesday or Wed, Thursday or Thu, Friday or Fri, Saturday or Sat, Sunday or Sun</li> <li>1 to 7 (1 is Sunday; 7 is Saturday)</li> </ul> <p>Name of the day is not case-sensitive. In the United States, the default is Sunday.</p>
dst_stop_month	<p>(Optional) Month in which DST ends. Valid values are January, February, March, April, May, June, July, August, September, October, November, and December or 1 through 12 with 1 being January and 12 being December. Name of the month is not case-sensitive. In the United States, the default is October.</p>
dst_stop_time	<p>(Optional) Time of day on which DST ends. Valid values are hour/minute (02/00) or hour:minute (02:00). In the United States, the default is 02:00.</p>
dst_stop_week_of_month	<p>(Optional) Week of month in which DST begins. Valid values are 1 to 6 and 8 (1 is the first week; each subsequent number is a subsequent week; 8 is the last week in the month regardless of which week the last week is). In the United States, the default is 1.</p>
dtmf_avt_payload	<p>(Optional) Payload type for audio-video transport (AVT) packets. Range is 96 to 127. If the value specified is null or invalid, default is 101.</p>
dtmf_inband	<p>(Optional) In-band signaling format.</p> <p>Valid values are 1 (generate DTMF digits in-band) and 0 (do not generate DTMF digits in-band). Default is 1.</p>
dtmf_outofband	<p>(Optional) Out-of-band signaling for tone detection on the IP side of a gateway. The phone supports out-of-band signaling using the AVT tone method. Valid values are the following:</p> <ul style="list-style-type: none"> <li>none—Do not generate DTMF digits out-of-band.</li> <li>avt—If requested by the remote side, generate DTMF digits out-of-band (and disable in-band DTMF signaling); otherwise, do not generate DTMF digits out-of-band.</li> <li>avt_always—Always generate DTMF digits out-of-band. This option disables in-band DTMF signaling.</li> </ul> <p>Default is avt.</p>

**Table B-1 Parameters in the Default Configuration File (continued)**

MGCP Parameter	Description
dyn_dns_addr_1	<p>(Optional) IP address of a new dynamic DNS server. If a new DNS server address is specified, it is used for any further DNS requests after the phone uses the initial DNS address upon bootup. DNS addresses are used in the following order:</p> <ol style="list-style-type: none"> <li>1. dyn_dns_addr_1 (if present)</li> <li>2. dyn_dns_addr_2 (if present)</li> <li>3. DNS Server 1</li> <li>4. DNS Server 2</li> <li>5. DNS Server 3</li> <li>6. DNS Server 4</li> <li>7. DNS Server 5</li> </ol> <p>The dynamic address is not stored in flash memory. Only dotted IP addresses are accepted. You can clear this value by removing it from the configuration file or by changing its value to a null value “ ” or to “UNPROVISIONED.”</p>
dyn_dns_addr_2	(Optional) IP address of a second dynamic DNS server to be used for DNS requests.
dyn_tftp_addr	<p>(Optional) IP address of a new dynamic TFTP server. After initially querying the default TFTP server, the phone rerequests the default and phone-specific configuration files from the new TFTP server. The dynamic TFTP server address is not stored in flash memory. The number of dyn_tftp_addr values supported by the phone is limited to prevent the phone configuration being downloaded repeatedly from multiple TFTP servers. Only dotted IP addresses are accepted. This value can be cleared by removing it from the configuration file or by changing its value to a null value “ ” or to “UNPROVISIONED.”</p>
end_media_port	(Optional) Configures the Real-Time Transport Protocol (RTP) end range for media. Valid values are from 16384 to 32766. Default is 32766.
http_proxy_addr	(Optional) IP address of the HTTP proxy server. You can use either a dotted IP address or a DNS name (a record only).
http_proxy_port	(Optional) Number of the HTTP proxy port. Default is 80.
image_version	<p>Firmware version that the phone uses. Enter the name of the image version as it is released by Cisco. Do not enter the filename extension (.bin).</p> <p><b>Note</b> You cannot change the image version by changing the filename because the version is also built into the file header. Trying to change the image version by changing the filename causes the firmware to fail when the firmware compares the version in the header against the filename.</p>
language	(Optional) This parameter is for future use. The only valid value is English.

**Table B-1 Parameters in the Default Configuration File (continued)**

<b>MGCP Parameter</b>	<b>Description</b>
logo_url	(Optional) Location of the company logo file. This logo appears on the phone display. The background space allocated for the image is 90 x 56 pixels. Images that are larger than this automatically scale down to 90 x 56 pixels. The recommended file size for the image is from 5 to 15 kilobytes. For example, use logo_url http://10.10.10.10/companylogo.bmp.  <b>Note</b> This parameter supports Windows 256 color bitmap format only. CMXML PhoneImage objects are not supported for this parameter. Using anything other than a Windows bitmap (.bmp) file can cause unpredictable results.
mgcp_endpoint_id	Configures the MGCP endpoint identifier. This parameter is a text string that can be up to 32 characters in length. The default value is d001, which is the same as the old hard-coded value.
mgcp_gw_controller	IP address of the call agent (CA).
mgcp_input_port	Port on which the phone listens. Default is 2427.
mgcp_keepalive	Whether to use the Restart In Progress (RSIP) keepalive to keep Network Address Translation (NAT) bindings open to the CA. Valid values are 0 (off) and 1 (on). Default is 0.
mgcp_keepalive_timer	Time interval, in seconds, for the MGCP keepalive timer. Range is 10 to 600. Default is 30.
mgcp_output_port	Port on which the the phone transmits. Default is 2427.
nat_address	(Optional) WAN IP address of the NAT or firewall server. You can use either a dotted IP address or a DNS name (a record only).
nat_enable	(Optional) Enables NAT. If NAT is enabled, the Session Description Protocol (SDP) message uses the nat_address and an RTP port between the start_media_port and the end_media_port range in the C and M fields. All RTP traffic is sourced from the port advertised in the SDP message. Valid values are 0 (disable) and 1 (enable). Default is 0.
phone_label	Text to display on the top right status line of the LCD. This field is for end-user display only and has no effect on caller identification or messaging. For example, a phone label can display "User A's phone." Up to 11 characters can be used to specify the phone label.
phone_password	(Optional) Password for console or Telnet access. Limited to 32 characters. Default is cisco.
phone_prompt	(Optional) Prompt that displays during Telnet or console access. Limited to 16 characters. Default is MGCP Phone.
services_url	URL of the services BTXML files to access when the Services button is pressed. For example, use services_url http://10.10.10.10/CiscoServices/Services.asp.
sntp_mode	Mode in which the phone listens for the Simple Network Time Protocol (SNTP) server. Valid values are unicast, multicast, anycast, and directedbroadcast. Default is anycast.

Table B-1 Parameters in the Default Configuration File (continued)

MGCP Parameter	Description
sntp_server	IP address of the SNTP server from which the phone obtains time data. If the SNTP server is set to 0 or is not set, the MGCP software defaults the SNTP server address to the address of the CA.
start_media_port	(Optional) Start RTP range for media. Range is from 16384 to 32766. Default is 16384.
stutter_msg_waiting	(Optional) Enables a stutter dial tone when there is a message waiting. Valid values are 0 (off) and 1 (on). Default is 0.
telnet_level	(Optional) Enables Telnet for the phone. Valid values are 0 (disabled), 1 (enabled without privileged commands), and 2 (enabled with privileged commands). Default is 0.
tftp_cfg_dir <sup>1</sup>	Path to the TFTP subdirectory in which phone-specific configuration files are stored. Limited to 64 characters. <b>Note</b> This parameter exists only in the MGCDefault.cnf file.
time_format_24hr	(Optional) Whether 12- or 24-hour time format displays by default on the phone. Valid values are the following: <ul style="list-style-type: none"> <li>0—12-hour format is displayed by default but can be changed to 24-hour format from the user interface.</li> <li>1—24-hour format is displayed by default but can be changed to 12-hour format from the user interface.</li> <li>2—12-hour format is displayed and cannot be changed to 24-hour format from the user interface.</li> <li>3—24-hour format is displayed and cannot be changed to 12-hour format from the user interface.</li> </ul> Default is 1.
time_zone	Time zone in which the phone is located. Abbreviations are case sensitive and must be in all capital letters. For a list of time zones, see Table 3-2 on page 3-17. Default is PST.
tos_media	(Optional) Type of service (ToS) level for the media stream being used. Valid values are the following: <ul style="list-style-type: none"> <li>0—IP_ROUTINE</li> <li>1—IP_PRIORITY</li> <li>2—IP_IMMEDIATE</li> <li>3—IP_FLASH</li> <li>4—IP_OVERRIDE</li> <li>5—IP_CRITIC</li> </ul> Default is 5.
use_domain_name_braces	Whether MGCP will add [ ] around the IP address on the endpoint identifier. This is a boolean field; it is either turned on or turned off. Valid values are 0 (off) and 1 (on). Default is 0.

**Table B-1 Parameters in the Default Configuration File (continued)**

<b>MGCP Parameter</b>	<b>Description</b>
use_mac_name	Whether to use the IP address or the MAC address in the endpoint name. Valid values are 0 (IP address) and 1 (MAC address). Default is 0.
user_info	(Optional) Configures the “user=” parameter in the REGISTER message. Valid values are the following: <ul style="list-style-type: none"> <li>• none—No value is inserted.</li> <li>• phone—The value user=phone is inserted in the To, From, and Contact headers for REGISTER.</li> <li>• ip—The value user=ip is inserted in the To, From, and Contact headers for REGISTER.</li> </ul> Default is none.
xml_card_dir	(Optional) Directory to use for retrieving the XML cards file. The base for the directory is the base TFTP server directory. Limited to 64 characters.
xml_card_file	(Optional) Filename of the XML cards. Limited to 20 characters.

1. Required if the phone-address configuration files are located in a subdirectory.

