

Cisco Unified IP Phone 7960G and 7940G Guide for Cisco Unified CallManager 4.2(3)







INCLUDING LICENSE AND WARRANTY

Corporate Headquarters

Cisco Systems, Inc.
170 West Tasman Drive
San Jose, CA 95134-1706
USA
<http://www.cisco.com>
Tel: 408 526-4000
800 553-NETS (6387)
Fax: 408 526-4100



Common Phone Tasks

View online help on the phone.	Press  or  twice quickly.
Place a call	Go off-hook before or after dialing a number.
Redial a number	Press Redial .
Switch to the speaker or headset during a call.	Press  or press  , then hang up the handset.
Mute your phone	Press  .
Use your call logs	Choose  to choose a call log. To dial, highlight a listing and go off-hook.
Edit a number	Press EditDial , << or >>.
Hold/resume a call	Press Hold or Resume .
Transfer a call to a new number	Press Transfer , enter a target number, then press Transfer again.
Start a standard conference call	Press more > Confrn . Dial a number, then press Confrn again. Repeat for each party.



Copyright © 2006 Cisco Systems, Inc. All rights reserved. Cisco, Cisco IOS, Cisco Systems, and the Cisco Systems logo are registered trademarks of Cisco Systems, Inc. or its affiliates in the U.S. and certain other countries. All other brands, names, or trademarks mentioned in this document or Web site are the property of their respective owners. The use of the word partner does not imply a partnership relationship between Cisco and any other company. (0501R)



Cisco Unified IP Phone 7960G and 7940G for Cisco Unified CallManager 4.2(3)

Softkey Definitions
 Phone Screen Icons
 Button Icons
 Common Phone Tasks









Softkey Definitions

AbbrDial	Dial using a speed dial index number
Answer	Answer a call
Barge	Add yourself to a call on a shared line
CallBack	Receive notification when a busy extension becomes available
Cancel	Cancel an action or exit a screen without applying changes
cBarge	Add yourself to a call on a shared line and establish a conference
CFwdALL	Setup/cancel call forwarding
Clear	Delete records or settings
Conflist	View conference participants
Confrn	Create a conference call
Delete	Remove characters at the cursor when using EditDial
Dial	Dial a phone number
DirTrfr	Transfer two calls to each other
EditDial	Edit a number in a call log
EndCall	Disconnect current call
Exit	Return to the previous screen
GPickUp	Answer a call ringing in another group
HLog	Prevent hunt group calls from ringing on your phone by logging out of hunt groups
iDivert	Send a call to your voice messaging system
Join	Join several calls already on a single line to create a conference



MeetMe	Host a Meet-Me conference call
more	Display additional softkeys
NewCall	Make a new call
OPickUp	Answer a call ringing in another group that is associated with your group
Park	Store a call using Call Park
PickUp	Answer a call in your group
QRT	Submit call problems to the system administrator
Redial	Redial the most recently dialed number
Remove	Remove a conference participant
Resume	Resume a call on hold
RmLstC	Drop the last party added to a conference call
Save	Save the chosen settings
Search	Search for a directory listing
Select	Select an item on the screen
Transfer	Transfer a call
Update	Refresh content
VidMode	Choose a video display mode
<<	Delete characters to left of the cursor
>>	Move through entered characters

Phone Screen Icons



Line and Call States

	Call Forwarding enabled
	Call on hold
	Connected call
	Hold Reversion call
	Incoming call
	Off-hook line
	Outgoing call
	Shared line in use





Secure Calls

	Authenticated call
	Encrypted call







Selected Device

	Handset in use
	Headset in use
	Speakerphone in use







Critical Calls

	Priority call
	Medium priority call
	High priority call
	Highest priority call

Other Features

	Phone line
	Speed-Dial button configured
	Web-based phone service
	Message waiting
	Video enabled
	Call selected
	Option enabled

Button Icons

	Messages
	Services
	Help
	Directories
	Settings
	Speaker
	Mute
	Headset



Contents

Getting Started 1

Using this Guide 1

Finding Additional Information 2

 Accessing Cisco Unified IP Phone 7900 Series eLearning Tutorials 2

 Customizing Your Phone on the Web 2

Safety and Performance Information 2

Accessibility Features 12

Connecting Your Phone 13

An Overview of Your Phone 16

Understanding Buttons and Hardware 16

Understanding Phone Screen Features 19

 Cleaning the Phone Screen 20

Understanding Feature Buttons and Menus 20

 Understanding the Help System on Your Phone 21

Understanding Lines vs. Calls 21

 Understanding Line and Call Icons 21

Understanding Feature Availability 22

Basic Call Handling 23

Placing a Call—Basic Options 23

Placing a Call—Additional Options 24

Answering a Call 25

Ending a Call 26

Using Hold and Resume 26

Using Mute 27

Switching Between Multiple Calls 27

Viewing Multiple Calls	28
Transferring Calls	28
Forwarding All Calls to Another Number	29
Making Conference Calls	30
Understanding Types of Conference Calls	30
Starting and Joining a Standard Conference	31
Starting or Joining a Meet-Me Conference Call	33

Advanced Call Handling 34

Speed Dialing	34
Picking Up Redirected Calls on Your Phone	35
Using a Shared Line	36
Understanding Shared Lines	36
Adding Yourself to a Shared-Line Call	36
Preventing Others from Viewing or Joining a Shared-Line Call	37
Storing and Retrieving Parked Calls	38
Making and Receiving Secure Calls	39
Tracing Suspicious Calls	40
Prioritizing Critical Calls	40
Using Cisco Extension Mobility	41
Logging Out of Hunt Groups	42

Using a Handset, Headset, and Speakerphone 43

Obtaining a Headset	43
Using AutoAnswer	44

Using Phone Settings 45

Customizing Rings and Message Indicators	45
Customizing the Phone Screen	46

Using Call Logs and Directories 47

Using Call Logs 47

Directory Dialing 48

 Using Corporate Directory on Your Phone 48

 Using Personal Directory on Your Phone 49

Accessing Voice Messages 50

Accessing Your User Options Web Pages 51

Logging In to the User Options Web Pages 51

Subscribing to Phone Services 52

Understanding Additional Configuration Options 53

Troubleshooting Your Phone 55

General Troubleshooting 55

Viewing Phone Administration Data 56

Using the Quality Reporting Tool 56

Cisco One-Year Limited Hardware Warranty Terms 57



Index 59



Getting Started

Using this Guide

This guide provides you with an overview of the features available on your phone. You can read it completely for a solid understanding of your phone's capabilities, or refer to the table below for pointers to commonly used sections.

If you want to...	Then...
Explore your phone on your own	Press  or  on the phone when you need assistance.
Review safety information	See Safety and Performance Information , page 2.
Connect your phone	See Connecting Your Phone , page 13.
Use your phone after it is installed	Start with An Overview of Your Phone , page 16.
Learn about the phone buttons	See Understanding Buttons and Hardware , page 16.
Learn about the phone screen	See Understanding Phone Screen Features .
Make calls	See Placing a Call—Basic Options , page 23.
Put calls on hold	See Using Hold and Resume , page 26.
Mute calls	See Using Mute , page 27.
Transfer calls	See Transferring Calls , page 28.
Make conference calls	See Making Conference Calls , page 30.
Set up speed dialing	See Speed Dialing , page 34.
Share a phone number	See Using a Shared Line , page 36.
Use your phone as a speakerphone	See Using a Handset, Headset, and Speakerphone , page 43.
Change ring volume or tone	See Using Phone Settings , page 45.
View your missed calls	See Using Call Logs , page 47.
Listen to your voice messages	See Accessing Voice Messages , page 50.
See softkey and icon definitions	Refer to the Quick Reference Card in the front of this guide.

Finding Additional Information

You can access the most current Cisco Unified IP Phone documentation on the World Wide Web at this URL:

http://www.cisco.com/univercd/cc/td/doc/product/voice/c_ipphon/index.htm

You can access the Cisco website at this URL:

<http://www.cisco.com/>

International Cisco websites can be accessed from this URL:

http://www.cisco.com/public/countries_languages.shtml

Accessing Cisco Unified IP Phone 7900 Series eLearning Tutorials

Cisco Unified IP Phone 7900 Series eLearning tutorials use audio and animation to demonstrate basic calling features. You can access eLearning tutorials online (for several phone models) from your personal computer. Look for the eLearning tutorial (English only) for your phone model in the documentation list at the following location:

http://cisco.com/en/US/products/hw/phones/ps379/products_user_guide_list.html

Customizing Your Phone on the Web

Your Cisco Unified IP Phone is a network device that can share information with other network devices in your company, including your computer. You can use your Cisco Unified CallManager User Options web pages to establish and customize phone services and to control phone features and settings from your computer. This guide provides a brief overview of these capabilities. For complete instructions, refer to *Customizing Your Cisco Unified IP Phone on the Web* at the following URL:

http://www.cisco.com/univercd/cc/td/doc/product/voice/c_ipphon/index.htm

Safety and Performance Information

Read the following safety notices before installing or using your Cisco Unified IP Phone:



Warning

IMPORTANT SAFETY INSTRUCTIONS

This warning symbol means danger. You are in a situation that could cause bodily injury. Before you work on any equipment, be aware of the hazards involved with electrical circuitry and be familiar with standard practices for preventing accidents. Use the statement number provided at the end of each warning to locate its translation in the translated safety warnings that accompanied this device. Statement 1071

SAVE THESE INSTRUCTIONS

Waarschuwing

BELANGRIJKE VEILIGHEIDSINSTRUCTIES

Dit waarschuwingssymbool betekent gevaar. U verkeert in een situatie die lichamelijk letsel kan veroorzaken. Voordat u aan enige apparatuur gaat werken, dient u zich bewust te zijn van de bij elektrische schakelingen betrokken risico's en dient u op de hoogte te zijn van de standaard praktijken om ongelukken te voorkomen. Gebruik het nummer van de verklaring onderaan de waarschuwing als u een vertaling van de waarschuwing die bij het apparaat wordt geleverd, wilt raadplegen.

BEWAAR DEZE INSTRUCTIES

Varoitus

TÄRKEITÄ TURVALLISUUSOHJEITA

Tämä varoitusmerkki merkitsee vaaraa. Tilanne voi aiheuttaa ruumiillisia vammoja. Ennen kuin käsittelet laitteistoa, huomioi sähköpiirien käsittelyyn liittyvät riskit ja tutustu onnettomuuksien yleisiin ehkäisytapoihin. Turvallisuusvaroitusten käännökset löytyvät laitteen mukana toimitettujen käännettyjen turvallisuusvaroitusten joukosta varoitusten lopussa näkyvien lausuntonumeroiden avulla.

SÄILYTÄ NÄMÄ OHJEET

Attention IMPORTANTES INFORMATIONS DE SÉCURITÉ

Ce symbole d'avertissement indique un danger. Vous vous trouvez dans une situation pouvant entraîner des blessures ou des dommages corporels. Avant de travailler sur un équipement, soyez conscient des dangers liés aux circuits électriques et familiarisez-vous avec les procédures couramment utilisées pour éviter les accidents. Pour prendre connaissance des traductions des avertissements figurant dans les consignes de sécurité traduites qui accompagnent cet appareil, référez-vous au numéro de l'instruction situé à la fin de chaque avertissement.

CONSERVEZ CES INFORMATIONS

Warnung WICHTIGE SICHERHEITSHINWEISE

Dieses Warnsymbol bedeutet Gefahr. Sie befinden sich in einer Situation, die zu Verletzungen führen kann. Machen Sie sich vor der Arbeit mit Geräten mit den Gefahren elektrischer Schaltungen und den üblichen Verfahren zur Vorbeugung vor Unfällen vertraut. Suchen Sie mit der am Ende jeder Warnung angegebenen Anweisungsnummer nach der jeweiligen Übersetzung in den übersetzten Sicherheitshinweisen, die zusammen mit diesem Gerät ausgeliefert wurden.

BEWAHREN SIE DIESE HINWEISE GUT AUF.

Avvertenza IMPORTANTI ISTRUZIONI SULLA SICUREZZA

Questo simbolo di avvertenza indica un pericolo. La situazione potrebbe causare infortuni alle persone. Prima di intervenire su qualsiasi apparecchiatura, occorre essere al corrente dei pericoli relativi ai circuiti elettrici e conoscere le procedure standard per la prevenzione di incidenti. Utilizzare il numero di istruzione presente alla fine di ciascuna avvertenza per individuare le traduzioni delle avvertenze riportate in questo documento.

CONSERVARE QUESTE ISTRUZIONI

Advarsel VIKTIGE SIKKERHETSINSTRUKSJONER

Dette advarselssymbolet betyr fare. Du er i en situasjon som kan føre til skade på person. Før du begynner å arbeide med noe av utstyret, må du være oppmerksom på farene forbundet med elektriske kretser, og kjenne til standardprosedyrer for å forhindre ulykker. Bruk nummeret i slutten av hver advarsel for å finne oversettelsen i de oversatte sikkerhetsadvarslene som fulgte med denne enheten.

TA VARE PÅ DISSE INSTRUKSJONENE**Aviso INSTRUÇÕES IMPORTANTES DE SEGURANÇA**

Este símbolo de aviso significa perigo. Você está em uma situação que poderá ser causadora de lesões corporais. Antes de iniciar a utilização de qualquer equipamento, tenha conhecimento dos perigos envolvidos no manuseio de circuitos elétricos e familiarize-se com as práticas habituais de prevenção de acidentes. Utilize o número da instrução fornecido ao final de cada aviso para localizar sua tradução nos avisos de segurança traduzidos que acompanham este dispositivo.

GUARDE ESTAS INSTRUÇÕES**¡Advertencia! INSTRUCCIONES IMPORTANTES DE SEGURIDAD**

Este símbolo de aviso indica peligro. Existe riesgo para su integridad física. Antes de manipular cualquier equipo, considere los riesgos de la corriente eléctrica y familiarícese con los procedimientos estándar de prevención de accidentes. Al final de cada advertencia encontrará el número que le ayudará a encontrar el texto traducido en el apartado de traducciones que acompaña a este dispositivo.

GUARDE ESTAS INSTRUCCIONES**Varning! VIKTIGA SÄKERHETSANVISNINGAR**

Denna varningssignal signalerar fara. Du befinner dig i en situation som kan leda till personskada. Innan du utför arbete på någon utrustning måste du vara medveten om farorna med elkretsar och känna till vanliga förfaranden för att förebygga olyckor. Använd det nummer som finns i slutet av varje varning för att hitta dess översättning i de översatta säkerhetsvarningar som medföljer denna anordning.

SPARA DESSA ANVISNINGAR

Figyelem

FONTOS BIZTONSÁGI ELOÍRÁSOK

Ez a figyelmeztető jel veszélyre utal. Sérülésveszélyt rejtő helyzetben van. Mielőtt bármely berendezésen munkát végezte, legyen figyelemmel az elektromos áramkörök okozta kockázatokra, és ismerkedjen meg a szokásos balesetvédelmi eljárásokkal. A kiadványban szereplő figyelmeztetések fordítása a készülékhez mellékelte biztonsági figyelmeztetések között található; a fordítás az egyes figyelmeztetések végén látható szám alapján kereshető meg.

ORIZZE MEG EZEKET AZ UTASÍTÁSOKAT!

Предупреждение

ВАЖНЫЕ ИНСТРУКЦИИ ПО СОБЛЮДЕНИЮ ТЕХНИКИ БЕЗОПАСНОСТИ

Этот символ предупреждения обозначает опасность. То есть имеет место ситуация, в которой следует опасаться телесных повреждений. Перед эксплуатацией оборудования выясните, каким опасностям может подвергаться пользователь при использовании электрических цепей, и ознакомьтесь с правилами техники безопасности для предотвращения возможных несчастных случаев. Воспользуйтесь номером заявления, приведенным в конце каждого предупреждения, чтобы найти его переведенный вариант в переводе предупреждений по безопасности, прилагаемом к данному устройству.

СОХРАНИТЕ ЭТИ ИНСТРУКЦИИ

警告

重要的安全性说明

此警告符号代表危险。您正处于可能受到严重伤害的工作环境中。在您使用设备开始工作之前，必须充分意识到触电的危险，并熟练掌握防止事故发生的标准工作程序。请根据每项警告结尾提供的声明号码来找到此设备的安全性警告说明的翻译文本。

请保存这些安全性说明

警告 安全上の重要な注意事項

「危険」の意味です。人身事故を予防するための注意事項が記述されています。装置の取り扱い作業を行うときは、電気回路の危険性に注意し、一般的な事故防止策に留意してください。警告の各国語版は、各注意事項の番号を基に、装置に付属の「Translated Safety Warnings」を参照してください。

これらの注意事項を保管しておいてください。

주의 중요 안전 지침

이 경고 기호는 위험을 나타냅니다. 작업자가 신체 부상을 일으킬 수 있는 위험한 환경에 있습니다. 장비에 작업을 수행하기 전에 전기 회로와 관련된 위험을 숙지하고 표준 작업 관례를 숙지하여 사고를 방지하십시오. 각 경고의 마지막 부분에 있는 경고문 번호를 참조하여 이 장치와 함께 제공되는 번역된 안전 경고문에서 해당 번역문을 찾으십시오.

이 지시 사항을 보관하십시오.

Aviso **INSTRUÇÕES IMPORTANTES DE SEGURANÇA**

Este símbolo de aviso significa perigo. Você se encontra em uma situação em que há risco de lesões corporais. Antes de trabalhar com qualquer equipamento, esteja ciente dos riscos que envolvem os circuitos elétricos e familiarize-se com as práticas padrão de prevenção de acidentes. Use o número da declaração fornecido ao final de cada aviso para localizar sua tradução nos avisos de segurança traduzidos que acompanham o dispositivo.

GUARDE ESTAS INSTRUÇÕES**Advarsel** **VIGTIGE SIKKERHEDSANVISNINGER**

Dette advarselssymbol betyder fare. Du befinder dig i en situation med risiko for legemeskade. Før du begynder arbejde på udstyr, skal du være opmærksom på de involverede risici, der er ved elektriske kredsløb, og du skal sætte dig ind i standardprocedurer til undgåelse af ulykker. Brug erklæringsnummeret efter hver advarsel for at finde oversættelsen i de oversatte advarsler, der fulgte med denne enhed.

GEM DISSE ANVISNINGER

تحذير

إرشادات الأمان الهامة

يوضح رمز التحذير هذا وجود خطر. وهذا يعني أنك متواجد في مكان قد ينتج عنه التعرض لإصابات. قبل بدء العمل، احذر مخاطر التعرض للصدمات الكهربائية وكن على علم بالإجراءات القياسية للحيلولة دون وقوع أي حوادث. استخدم رقم البيان الموجود في آخر كل تحذير لتحديد مكان ترجمته داخل تحذيرات الأمان المترجمة التي تأتي مع الجهاز. قم بحفظ هذه الإرشادات

Upozorenje

VAŽNE SIGURNOSNE NAPOMENE

Ovaj simbol upozorenja predstavlja opasnost. Nalazite se u situaciji koja može prouzročiti tjelesne ozljede. Prije rada s bilo kojim uređajem, morate razumjeti opasnosti vezane uz električne sklopove, te biti upoznati sa standardnim načinima izbjegavanja nesreća. U prevedenim sigurnosnim upozorenjima, priloženima uz uređaj, možete prema broju koji se nalazi uz pojedino upozorenje pronaći i njegov prijevod.

SAČUVAJTE OVE UPUTE

Upozornění

DŮLEŽITÉ BEZPEČNOSTNÍ POKYNY

Tento upozorňující symbol označuje nebezpečí. Jste v situaci, která by mohla způsobit nebezpečí úrazu. Před prací na jakémkoliv vybavení si uvědomte nebezpečí související s elektrickými obvody a seznamte se se standardními opatřeními pro předcházení úrazům. Podle čísla na konci každého upozornění vyhledejte jeho překlad v přeložených bezpečnostních upozorněních, která jsou přiložena k zařízení.

USCHOVEJTE TYTO POKYNY

Προειδοποίηση

ΣΗΜΑΝΤΙΚΕΣ ΟΔΗΓΙΕΣ ΑΣΦΑΛΕΙΑΣ

Αυτό το προειδοποιητικό σύμβολο σημαίνει κίνδυνο. Βρίσκεστε σε κατάσταση που μπορεί να προκαλέσει τραυματισμό. Πριν εργαστείτε σε οποιοδήποτε εξοπλισμό, να έχετε υπόψη σας τους κινδύνους που σχετίζονται με τα ηλεκτρικά κυκλώματα και να έχετε εξοικειωθεί με τις συνήθειες πρακτικές για την αποφυγή ατυχημάτων. Χρησιμοποιήστε τον αριθμό δήλωσης που παρέχεται στο τέλος κάθε προειδοποίησης, για να εντοπίσετε τη μετάφρασή της στις μεταφρασμένες προειδοποιήσεις ασφαλείας που συνοδεύουν τη συσκευή.

ΦΥΛΑΞΤΕ ΑΥΤΕΣ ΤΙΣ ΟΔΗΓΙΕΣ

אזהרה

הוראות בטיחות חשובות

סימן אזהרה זה מסמל סכנה. אתה נמצא במצב העלול לגרום לפציעה. לפני שתעבוד עם ציוד כלשהו, עליך להיות מודע לסכנות הכרוכות במעגלים חשמליים ולהכיר את הנהלים המקובלים למניעת תאונות. השתמש במספר ההוראה המסופק בסופה של כל אזהרה כדי לאתר את התרגום באזהרות הבטיחות המתורגמות שמצורפות להתקן.

שמור הוראות אלה

Opomena

ВАЖНИ БЕЗБЕДНОСНИ НАПАТСТВИЈА

Симболот за предупредување значи опасност. Се наоѓате во ситуација што може да предизвика телесни повреди. Пред да работите со опремата, бидете свесни за ризикот што постои кај електричните кола и треба да ги познавате стандардните постапки за спречување на несреќни случаи. Искористете го бројот на изјавата што се наоѓа на крајот на секое предупредување за да го најдете неговиот период во преведените безбедносни предупредувања што се испорачани со уредот.
ЧУВАЈТЕ ГИ ОВИЕ НАПАТСТВИЈА

Ostrzeżenie

WAŻNE INSTRUKCJE DOTYCZĄCE BEZPIECZEŃSTWA

Ten symbol ostrzeżenia oznacza niebezpieczeństwo. Zachodzi sytuacja, która może powodować obrażenia ciała. Przed przystąpieniem do prac przy urządzeniach należy zapoznać się z zagrożeniami związanymi z układami elektrycznymi oraz ze standardowymi środkami zapobiegania wypadkom. Na końcu każdego ostrzeżenia podano numer, na podstawie którego można odszukać tłumaczenie tego ostrzeżenia w dołączonym do urządzenia dokumencie z tłumaczeniami ostrzeżeń.

NINIEJSZE INSTRUKCJE NALEŻY ZACHOWAĆ

Upozornenie DÔLEŽITÉ BEZPEČNOSTNÉ POKYNY

Tento varovný symbol označuje nebezpečenstvo. Nachádzate sa v situácii s nebezpečenstvom úrazu. Pred prácou na akomkoľvek vybavení si uvedomte nebezpečenstvo súvisiace s elektrickými obvodmi a oboznámte sa so štandardnými opatreniami na predchádzanie úrazom. Podľa čísla na konci každého upozornenia vyhľadajte jeho preklad v preložených bezpečnostných upozorneniach, ktoré sú priložené k zariadeniu.

USCHOVAJTE SI TENTO NÁVOD



Warning

Read the installation instructions before you connect the system to its power source.



Warning

Ultimate disposal of this product should be handled according to all national laws and regulations.



Warning

Do not work on the system or connect or disconnect cables during periods of lightning activity.



Warning

To avoid electric shock, do not connect safety extra low voltage (SELV) circuits to telephone network voltage (TNV) circuits. LAN ports contain SELV circuits, and WAN ports contain TNV circuits. Some LAN and WAN ports use RJ-45 connectors. Use caution when connecting cables.



Caution

Inline power circuits provide current through the communication cable. Use the Cisco provided cable or a minimum 24 AWG communication cable.

Using an External Power Supply

The following warnings apply when you use the external power supply with the Cisco Unified IP Phone:

**Warning**

This product relies on the building's installation for short-circuit (over current) protection. Ensure that a fuse or circuit breaker no larger than 120 VAC, 15A U.S. (240 VAC, 10A international) is used on the phase conductors (all current-carrying conductors).

**Warning**

The device is designed to work with TN power systems.

**Warning**

The plug-socket combination must be accessible at all times because it serves as the main disconnecting device.

**Warning**

The power supply must be placed indoors.

**Caution**

Only use the Cisco specified power supply with this product.

Power Outages

Your accessibility to emergency service through the phone is dependent on the phone being powered. If there is an interruption in the power supply, Service and Emergency Calling Service dialing will not function until power is restored. In the case of a power failure or disruption, you may need to reset or reconfigure equipment before using the Service or Emergency Calling Service dialing.

Using External Devices

The following information applies when you use external devices with the Cisco Unified IP Phone:

Cisco recommends the use of good quality external devices (speakers, microphones, and headsets) that are shielded against unwanted radio frequency (RF) and audio frequency (AF) signals.

Depending on the quality of these devices and their proximity to other devices such as mobile phones or two-way radios, some audio noise may still occur. In these cases, Cisco recommends that you take one or more of the following actions:

- Move the external device away from the source of the RF or AF signals.
- Route the external device cables away from the source of the RF or AF signals.
- Use shielded cables for the external device, or use cables with a better shield and connector.
- Shorten the length of the external device cable.
- Apply ferrites or other such devices on the cables for the external device.

Cisco cannot guarantee the performance of the system because Cisco has no control over the quality of external devices, cables, and connectors. The system will perform adequately when suitable devices are attached using good quality cables and connectors.



Caution

In European Union countries, use only external speakers, microphones, and headsets that are fully compliant with the EMC Directive [89/336/EC].

Accessibility Features

A list of accessibility features is available upon request.

Connecting Your Phone

Your system administrator will likely connect your new Cisco Unified IP Phone to the corporate IP telephony network. If that is not the case, refer to the graphic and table below to connect your phone.

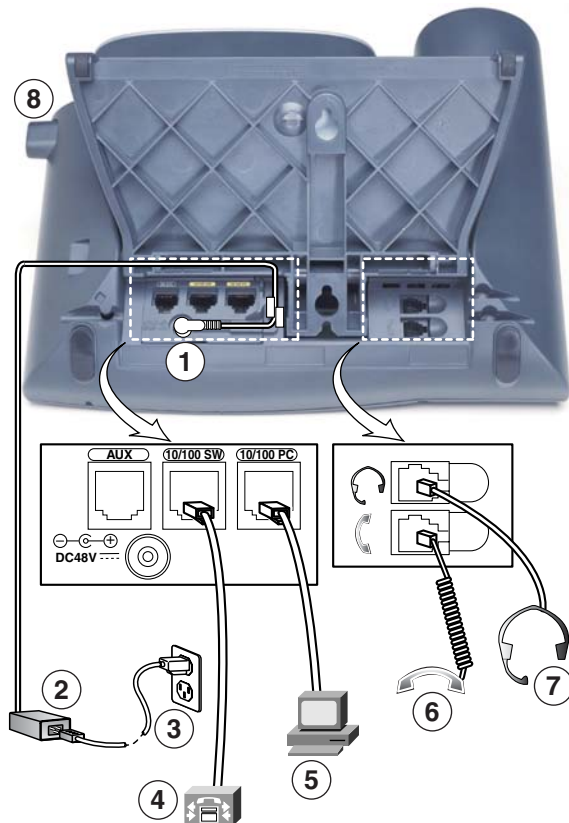

113656

1	DC adaptor port (DC48V) for phones not provided with inline power	5	Access port (10/100 PC) for connecting your phone to your computer
2	AC-to-DC power supply	6	Handset port
3	AC power cord	7	Headset port
4	Network port (10/100 SW) for connecting to the network	8	Footstand button

Adjusting the Footstand

To change the angle that your phone sits on your desktop, adjust the footstand while pressing the footstand button.

Adjusting the Handset Rest

When you connect your phone, you might want to adjust the handset rest to ensure that the receiver will not slip out of the cradle. See the table below for instructions.

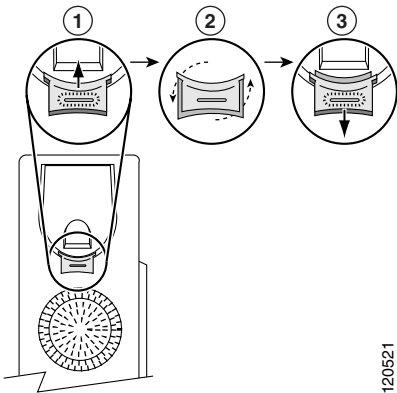

1	Set the handset aside and pull the square plastic tab from the handset rest.
2	Rotate the tab 180 degrees.
3	Slide the tab back into the handset rest. An extension protrudes from the top of the rotated tab. Return the handset to the handset rest.

Registering with TAPS

After your phone is connected to the network, your system administrator might ask you to auto-register your phone using TAPS (Tool for Auto-Registered Phones Support). TAPS might be used for a new phone or to replace an existing phone.

To register with TAPS, pick up the handset, enter the TAPS extension provided by your system administrator, and follow the voice prompts. You might need to enter your entire extension, including the area code. After your phone displays a confirmation message, hang up. The phone will re-start.

Headset Information

To use a headset, connect it to the headset port on the back of your phone.

Although Cisco Systems performs some internal testing of third-party headsets for use with the Cisco Unified IP Phones, Cisco does not certify or support products from headset or handset vendors. Because of the inherent environmental and hardware inconsistencies in the locations where

Cisco Unified IP Phones are deployed, there is not a single “best” solution that is optimal for all environments. Cisco recommends that customers test the headsets that work best in their environment before deploying a large number of units in their network.

In some instances, the mechanics or electronics of various headsets can cause remote parties to hear an echo of their own voice when they speak to Cisco Unified IP Phone users.

Cisco Systems recommends the use of good quality external devices, like headsets that are screened against unwanted radio frequency (RF) and audio frequency (AF) signals. Depending on the quality of these devices and their proximity to other devices such as cell phones and two-way radios, some audio noise may still occur. See [Using External Devices, page 11](#) for more information.

The primary reason that a particular headset would be inappropriate for the Cisco Unified IP Phone is the potential for an audible hum. This hum can be heard by either the remote party or by both the remote party and you, the Cisco Unified IP Phone user. Some potential humming or buzzing sounds can be caused by a range of outside sources, for example, electric lights, being near electric motors, large PC monitors. In some cases, a hum experienced by a user may be reduced or eliminated by using a local power cube or power injector. See [Using an External Power Supply, page 10](#) for more information.

Audio Quality Subjective to the User

Beyond the physical, mechanical and technical performance, the audio portion of a headset must sound good to you (the user) and to the party on the far end. Sound is subjective and Cisco cannot guarantee the performance of any headsets or handsets, but some of the headsets and handsets on the sites listed below have been reported to perform well on Cisco Unified IP Phones.

Nevertheless, it is ultimately still the customer's responsibility to test this equipment in their own environment to determine suitable performance.

For information about headsets, see:

<http://www.vxicorp.com/cisco>

<http://www.plantronics.com>

An Overview of Your Phone

Your Cisco Unified IP Phone 7960G or 7940G is a full-feature telephone that provides voice communication over the same data network that your computer uses, allowing you to place and receive phone calls, put calls on hold, transfer calls, make conference calls, and so on.

In addition to basic call-handling features, your phone can provide enhanced productivity features that extend your call-handling capabilities.

Depending on the configuration, your phone supports:

- Access to network data, XML applications, and web-based services.
- Online customizing of phone features and services from your User Options web pages.
- A comprehensive online help system that displays information on the phone screen.

Understanding Buttons and Hardware

You can use the illustrations below to identify buttons and hardware on your phone.

Figure 1 Cisco Unified IP Phone 7960G













68561

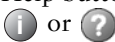

Figure 2 Cisco Unified IP Phone 7940G



68562

Item	Description	For more information, see...
1	Handset light strip Indicates an incoming call or new voice message.	Accessing Voice Messages, page 50
2	Phone screen Shows phone features.	Understanding Phone Screen Features, page 19





3	Model type	Indicates your Cisco Unified IP Phone model.	
4	Programmable buttons 	Depending on configuration, programmable buttons provide access to: <ul style="list-style-type: none"> • Phone lines (line buttons) • Speed-dial numbers (speed-dial buttons) • Directed Call Park numbers • Web-based services (for example, Personal Address Book) • Phone features (for example, Privacy) 	Understanding Phone Screen Features, page 19 Basic Call Handling, page 23 Speed Dialing, page 34 Storing and Retrieving Parked Calls, page 38 Subscribing to Phone Services, page 52
5	Footstand button	Allows you to adjust the angle of the phone base.	Adjusting the Footstand, page 14
6	Directories button 	Opens/closes the Directories menu. Use it to access call logs and corporate directories.	Using Call Logs and Directories, page 47
	Item	Description	For more information, see...
7	Help button 	Activates the Help menu.	Understanding the Help System on Your Phone, page 21
8	Settings button 	Opens/closes the Settings menu. Use it to control phone screen contrast and ring sounds.	Using Phone Settings, page 45
9	Speaker button 	Toggles the speakerphone on or off.	Using a Handset, Headset, and Speakerphone, page 43
10	Mute button 	Toggles the Mute feature on or off.	Using Mute, page 27
11	Headset button 	Toggles the headset on or off.	Using a Handset, Headset, and Speakerphone, page 43
12	Volume button 	Controls the volume and other settings.	Using a Handset, Headset, and Speakerphone, page 43
13	Services button 	Opens/closes the Services menu.	Accessing Your User Options Web Pages, page 51
14	Messages button 	Typically auto-dials your voice message service (varies by service).	Accessing Voice Messages, page 50

15	 <p>Navigation button</p>	<p>Allows you to scroll through menus and highlight items. Use in conjunction with softkeys to activate highlighted items.</p>	<p>Understanding Feature Buttons and Menus, page 20</p>
16	<p>Keypad</p>	<p>Allows you to dial phone numbers, enter letters, and choose menu items.</p>	<p>Basic Call Handling, page 23</p>
17	 <p>Softkey buttons</p>	<p>Each activates a softkey option (displayed on your phone screen).</p>	<p>Understanding Phone Screen Features, page 19</p>

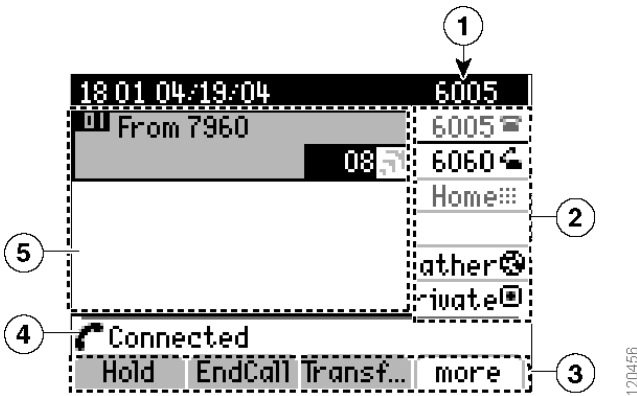
Understanding Phone Screen Features

This is what your main phone screen might look like with an active call and several feature menus open.



1	<p>Primary phone line</p>	<p>Displays the phone number (extension number) for your primary phone line.</p>
2	<p>Icons for programmable button</p>	<p>Icons indicate how programmable buttons  are set up on your phone:</p> <ul style="list-style-type: none">  Phone line icon—Corresponds to a phone line. Line icons can vary. See Understanding Lines vs. Calls, page 21.  Speed-dial icon—If available, corresponds to a speed-dial button. See the Speed Dialing, page 34.  Phone service icon—If available, corresponds to a web-based phone service, such as the Personal Address Book.  Feature icon—If available, corresponds to a feature, such as Privacy.





3	Softkey labels	Each displays a softkey function.
4	Status line	Displays audio mode icons, status information, and prompts.
5	Call activity area	Displays current calls per line, including caller ID, call duration, and call state. See Understanding Lines vs. Calls, page 21 and Understanding Line and Call Icons, page 21 .

Cleaning the Phone Screen

Gently wipe the phone screen with a soft, dry cloth. Do not use any liquids or powders on the phone. Using anything other than a soft, dry cloth can contaminate phone components and cause failures.









Understanding Feature Buttons and Menus

Press a feature button to open or close a feature menu.

If you want to...	Then...
Open or close a feature menu	Press a feature button: <ul style="list-style-type: none">  Messages  Services  Help  Directories  Settings
Scroll through a list or menu	Press the Navigation button.
Go back one level in a feature menu	Press Exit . Pressing Exit from the top level of a menu closes the menu.
Switch between open feature menus	Press a feature tab on your phone screen. Each feature menu has a corresponding tab. The tab is visible when the feature menu is open.

Understanding the Help System on Your Phone

Your Cisco Unified IP Phone provides on-the-spot help with specific buttons and features. Help topics appear on the phone screen. See the table below for details.

If you want to...	Then...
Learn about a button or softkey	Press  or  , then quickly press a button or softkey.
Learn about a menu item	Press  ,  , or  to display a feature menu. Then, highlight a menu item and press  or  twice quickly.
Get help using Help	Press  or  twice quickly (without first selecting a menu item).







Understanding Lines vs. Calls



To avoid confusion about lines and calls, refer to these descriptions:

- **Lines**—Each corresponds to a directory number that others can use to call you. The Cisco Unified IP Phone 7960G supports up to six lines and the Cisco Unified IP Phone 7940G supports up to two lines. To see how many lines you have, look at right side of your phone screen. You have as many lines as you have directory numbers and phone line icons: .
- **Calls**—Each line can support multiple calls. By default, your phone supports four connected calls per line, but your system administrator can adjust this number according to your needs. Only one call can be active at any time; other calls are automatically placed on hold.

Understanding Line and Call Icons

Your phone displays icons to help you determine the line and call state.

Icon	Line or call state	Description
	On-hook line	No call activity on this line.
	Off-hook line	You are dialing a number or an outgoing call is ringing.
	Outgoing call	An outgoing call has reached a busy line.
	Connected call	You are connected to the other party.
	Incoming call	A call is ringing on one of your lines.
	Call on hold	You have put this call on hold. See Using Hold and Resume , page 26.
	Reverting hold call	A call is alerting you after being put on hold. See Using Hold and Resume , page 26.

Icon	Line or call state	Description
	Remote-in-use	Another phone that shares your line has a connected call. See Using Hold and Resume, page 26 .
	Authenticated call	See Making and Receiving Secure Calls, page 39 .
	Encrypted call	See Making and Receiving Secure Calls, page 39 .

Understanding Feature Availability





The operation of your Cisco Unified IP Phone and the features available to you may vary, depending on the call processing agent used by your company and also on how your company's phone support team has configured your phone system. Therefore, some of the features included in this guide might not be available to you or might work differently on your phone system. Contact your support desk or system administrator for information about feature operation or availability.

Basic Call Handling



You can perform basic call-handling tasks using a range of features and services. Feature availability can vary; see your system administrator for more information.

Placing a Call—Basic Options

Here are some easy ways to place a call on your Cisco Unified IP Phone.





If you want to...	Then...	For more information, see...
Place a call using the handset	Pick up the handset and enter a number.	An Overview of Your Phone, page 16
Place a call using the speakerphone	Press  and enter a number.	Using a Handset, Headset, and Speakerphone, page 43
Place a call using a headset	Press  and enter a number. Or, if  is lit, press NewCall and enter a number.	Using a Handset, Headset, and Speakerphone, page 43
Redial a number	Press Redial to dial the last number.	Using Call Logs, page 47
Place a call while another call is active (using the same line)	<ol style="list-style-type: none"> 1. Press Hold. 2. Press NewCall. 3. Enter a number. 	Using Hold and Resume, page 26
Dial from a call log	<ol style="list-style-type: none"> 1. Choose  > Missed Calls, Received Calls, or Placed Calls. 2. Scroll to the listing on the phone screen and go off-hook. 	Using Call Logs, page 47

Tips

- You can dial on-hook, without a dial tone (pre-dial). To pre-dial, enter a number, then lift the handset to go off-hook, or press **Dial**, , or .
- If you make a mistake while dialing, press << to erase digits.

Placing a Call—Additional Options







You can place calls using special features and services that might be available on your phone. See your system administrator for more information about these additional options.

If you want to...	Then...	For more information, see...
Place a call while another call is active (using a different line)	<ol style="list-style-type: none"> 1. Press  for a new line. The first call is automatically placed on hold. 2. Enter a number. 	Using Hold and Resume, page 26
Speed dial a number	Do one of the following: <ul style="list-style-type: none"> • Press  (a speed-dial button). • Use the Abbreviated Dial feature. • Use the Fast Dial service. 	Speed Dialing, page 34
Dial from a corporate directory on your phone	<ol style="list-style-type: none"> 1. Choose  > Corporate Directory (name can vary). 2. Use your keypad to enter a name. 3. Press Search. 4. Scroll to a listing and go off-hook. 	Using Corporate Directory on Your Phone, page 48
Dial from a corporate directory on your personal computer using Cisco WebDialer	<ol style="list-style-type: none"> 1. Open a web browser and go to a WebDialer-enabled corporate directory. 2. Click the number that you want to dial. 	<i>Customizing Your Cisco Unified IP Phone on the Web:</i> http://www.cisco.com/univercd/cc/td/doc/product/voice/c_ipphon/index.htm
Use Cisco CallBack to receive notification when a busy or ringing extension is available	<ol style="list-style-type: none"> 1. Press CallBack while listening to the busy tone or ring sound. 2. Hang up. Your phone alerts you when the line is free. 3. Place the call again. 	Your system administrator
Make a priority (precedence) call	Enter the MLPP access number, then enter a phone number.	Prioritizing Critical Calls, page 40
Dial from a Personal Address Book (PAB) entry	<ol style="list-style-type: none"> 1. Choose  > PAB service. 2. Highlight a listing and go off-hook. 	Accessing Your User Options Web Pages, page 51

If you want to...	Then...	For more information, see...
Place a call using a billing or tracking code	<ol style="list-style-type: none"> 1. Dial a number. 2. After the tone, enter a client matter code (CMC) or a forced authorization code (FAC). 	Your system administrator
Place a call using your Extension Mobility profile	<ol style="list-style-type: none"> 1. Choose  > EM Service (name can vary). 2. Enter log in information. 	Using Cisco Extension Mobility, page 41



Answering a Call

You can answer a call by simply lifting the handset, or you can use other options if they are available on your phone.

If you want to...	Then...	For more information, see...
Answer with a headset	Press  , if unlit. Or, if  is lit, press Answer or  .	Using a Handset, Headset, and Speakerphone, page 43
Answer with the speakerphone	Press  , Answer , or  .	Using a Handset, Headset, and Speakerphone, page 43
Switch from a connected call to answer a ringing call	Press Answer or, if the call is ringing on a different line, press  .	Using Hold and Resume, page 26
Answer using call waiting	Press Answer .	Using Hold and Resume, page 26
Send call directly to your voice messaging system	Press iDivert .	Accessing Voice Messages, page 50
Auto- connect incoming calls	Use AutoAnswer .	Using AutoAnswer, page 44
Retrieve a parked call on another phone	Use Call Park or Directed Call Park .	Storing and Retrieving Parked Calls, page 38
Use your phone to answer a call ringing elsewhere	Use Call Pickup .	Picking Up Redirected Calls on Your Phone, page 35
Answer a priority call	Hang up the current call and press Answer .	Prioritizing Critical Calls, page 40

Ending a Call

To end a call, simply hang up. Here are some more details.



If you want to...	Then...
Hang up while using the handset	Return the handset to its cradle. Or press EndCall .
Hang up while using a headset	Press  . Or, to keep headset mode active, press EndCall .
Hang up while using the speakerphone	Press  or EndCall .
Hang up one call, but preserve another call on the same line	Press EndCall . If necessary, remove the call from hold first.

Using Hold and Resume

You can hold and resume calls. When you put a call on hold, the Hold icon  appears next to the caller ID.

If the Hold Reversion feature is enabled for your phone, calls that you leave on hold will revert back to ringing on your phone after a certain length of time. These “reverting” calls remain on hold until you resume them.

Your phone indicates the presence of a reverting call by:

- Alerting you at intervals with a single ring or beep, depending on your phone line setting).
- Briefly displaying a “Hold Reversion” message in the status bar at the bottom of the phone screen.
- Displaying the animated Hold Reversion icon    next to the caller ID for the held call.



If you want to...	Then...
Put a call on hold	<ol style="list-style-type: none">1. Make sure the appropriate call is highlighted.2. Press Hold.
Remove a call from hold on the current line	<ol style="list-style-type: none">1. Make sure the appropriate call is highlighted.2. Press Resume.
Remove a call from hold on a different line	<ol style="list-style-type: none">1. Press the appropriate line button: . Doing so might cause a held call to resume automatically:<ul style="list-style-type: none">• If there is a reverting call on the line, that call will resume.• If there is more than one reverting call on the line, the oldest reverting call will resume.• If a non-reverting held call is the only call on the line, it will resume.2. If necessary, scroll to the appropriate call and press Resume.

Tips

- Engaging the Hold feature typically generates music or a beeping tone.
- If you receive an alert for an incoming call and a reverting call at the same time, by default your phone will shift the focus of the phone screen to display the incoming call. Your phone administrator can change this focus priority setting.
- If you use a shared line, Hold Reversion rings only on the phone that put the call on hold, not on the other phones that share the line.
- The duration between Hold Reversion alerts is determined by your phone administrator.



Using Mute

With Mute enabled, you can hear other parties on a call but they cannot hear you. You can use Mute in conjunction with the handset, speakerphone, or a headset.

If you want to...	Then...
Toggle Mute on	Press  .
Toggle Mute off	Press  .

Switching Between Multiple Calls

You can switch between multiple calls on one or more lines. If the call that you want to switch to is not automatically highlighted on the phone screen, scroll to it.

If you want to...	Then...
Switch between connected calls on one line	<ol style="list-style-type: none"> 1. Make sure the call that you want to switch to is highlighted. 2. Press Resume. Any active call is placed on hold and the selected call is resumed.
Switch between connected calls on different lines	Press  for the line that you are switching to. If a single call is holding on the line, the call automatically resumes. If multiple calls are holding, highlight the appropriate call and press Resume .
Switch from a connected call to answer a ringing call	Press Answer, or if the call is ringing on a different line, press  . Any active call is placed on hold and the selected call is resumed.







Viewing Multiple Calls

Understanding how multiple calls are displayed on your phone can help you organize your call-handling efforts.

In standard viewing mode, your phone displays calls as follows for the highlighted line:

- Calls with the highest precedence and longest duration display at the top of the list.
- Calls of a similar type are grouped together. For example, calls that you have interacted with are grouped near the top, and ringing calls are grouped last.

You can use these additional methods to view multiple calls on multiple lines:

If you want to...	Then...
View calls on another line	<ol style="list-style-type: none">1. Press  or .2. Immediately press the line button .
Switch to call overview mode	<p>Press  for the highlighted line.</p> <p>The phone switches to call overview mode, displaying only one call per line. The displayed call is either the active call or the held call with the longest duration.</p> <p>To return to standard viewing mode, press  or , then immediately press the line button.</p>

Transferring Calls

Transfer redirects a connected call. The *target* is the number to which you want to transfer the call.

If you want to...	Then...
Transfer a call without talking to the transfer recipient	<ol style="list-style-type: none">1. From an active call, press Transfer.2. Enter the target number.3. Press Transfer again to complete the transfer or EndCall to cancel. <p>Note If your phone supports on-hook transfer, you can alternately complete the transfer by hanging up.</p>
Talk to the transfer recipient before transferring a call (consult transfer)	<ol style="list-style-type: none">1. From an active call, press Transfer.2. Enter the target number.3. Wait for the transfer recipient to answer.4. Press Transfer again to complete the transfer or EndCall to cancel. <p>Note If your phone supports on-hook transfer, you can alternately complete the transfer by hanging up.</p>

If you want to...	Then...
Transfer two current calls to each other (direct transfer) without staying on the line	<ol style="list-style-type: none"> 1. Scroll to highlight any call on the line. 2. Press Select. 3. Repeat this process for the second call. 4. With one of the selected calls highlighted, press DirTrfr. (To display DirTrfr, you might need to press more.) <p>The two calls connect to each other and drop you from the call.</p> <p>Note If you want to stay on the line with the callers, use Join instead.</p>
Redirect a call to your voice messaging system	Press iDivert . The call is automatically transferred to your voice message greeting. You can use iDivert with a call that is active, ringing, or on hold.



Tips

- If on-hook transfer is enabled on your phone, you can either hang up to complete the call, or press **Transfer** and then hang up.
- If on-hook transfer is *not* enabled on your phone, hanging up without pressing **Transfer** again places the call on hold.
- You cannot use **Transfer** to redirect a call on hold. Press **Resume** to remove the call from hold before transferring it.

Forwarding All Calls to Another Number

You can use Call Forward All to redirect incoming calls from your phone to another number.

If you want to...	Then...
Set up call forwarding on your primary line	Press CFwdALL and enter a target phone number.
Cancel call forwarding on your primary line	Press CFwdALL .

If you want to...	Then...
Verify that call forwarding is enabled on your primary line	Look for: <ul style="list-style-type: none"> • The call forward icon above the primary phone number:   • The call forward target number in the status line.
Set up or cancel call forwarding remotely, or for a non-primary line	<ol style="list-style-type: none"> 1. Log in to your User Options web pages. See Logging In to the User Options Web Pages, page 51. 2. Choose Forward all calls... 3. Choose your primary line or any secondary line.



Note When call forwarding is enabled for any line other than the primary line, your phone does not provide you with confirmation that calls are being forwarded. Instead, you must confirm your settings in the User Options web pages.

Tips

- Enter the call forward target number exactly as you would dial it from your phone. For example, enter an access code or the area code, if necessary.
- You can forward your calls to a traditional analog phone or to another IP phone, although your system administrator might restrict the call forwarding feature to numbers within your company.
- Call forwarding is phone line specific. If a call reaches you on a line where call forwarding is not enabled, the call will ring as usual.
- Your system administrator can change forwarding conditions for your phone lines.

Making Conference Calls

Your Cisco Unified IP Phone allows you to join three or more people into one telephone conversation, creating a conference call.

Understanding Types of Conference Calls

There are two types of conference calls: Standard and Meet-Me.

Standard Conference Calls

You can create a standard conference in different ways, depending on your needs and the softkeys available on your phone:

- **Confrn**—Use this softkey to establish a standard conference by calling each participant. Standard conference calling is a default feature available on most phones.
- **Join**—Use this softkey to establish a standard conference by joining several calls already on one line.
- **cBarge**—Use this softkey to add yourself to an existing call on a shared line and to turn the call into a standard conference call. This feature is available only on phones that use shared lines.

See [Starting and Joining a Standard Conference, page 31](#) for additional instructions.

Meet-Me Conference Calls

You can create a Meet-Me conference by calling the Meet-Me phone number at a specified time.

See [Starting or Joining a Meet-Me Conference Call, page 33](#) for additional instructions.

Starting and Joining a Standard Conference

A standard conference allows at least three participants to talk on a single call.

If you want to...	Then...
<ul style="list-style-type: none"> • Create a conference by calling participants • Add new participants to an existing conference 	<ol style="list-style-type: none"> 1. From a connected call, press Confrn. (You may need to press the more softkey to see Confrn.) 2. Enter the participant's phone number. 3. Wait for the call to connect. 4. Press Confrn again to add the participant to your call. 5. Repeat to add additional participants.
<p>Create a conference by joining two or more existing calls</p>	<ol style="list-style-type: none"> 1. Make sure that you have two or more calls on a single line. 2. Highlight a call that you want to add to the conference. 3. Press Select. The selected call displays this icon . 4. Repeat this process for each call that you want to add. 5. From one of the selected calls, press Join. (You may need to press the more softkey to see Join.) <p>Note The active call is automatically selected.</p>
<p>Participate in a conference</p>	<p>Answer the phone when it rings.</p>
<p>Create a conference by barging a call on a shared line</p>	<p>Highlight a call on a shared line and press cBarge. (You may need to press the more softkey to display cBarge.)</p> <p>See Using a Shared Line, page 36.</p>

If you want to...	Then...
View a list of conference participants	<ol style="list-style-type: none"> 1. Highlight an active conference. 2. Press ConfList. <p>Participants are listed in the order in which they join the conference with the most recent additions at the top.</p>
Get an updated list of participants	While viewing the conference list, press Update .
See who started the conference	While viewing the conference list, locate the person listed at the bottom of the list with an asterisk (*) next to the name.
Drop the last party added to the conference	<p>Press RmLstC.</p> <p>You can remove participants only if you initiated the conference call.</p>
Remove any conference participant	<ol style="list-style-type: none"> 1. While viewing the conference list, highlight the participant's name. 2. Press Remove. <p>You can remove participants only if you initiated the conference.</p>
End your participation in a conference	Hang up or press EndCall .

Tips

- Calls must be on the same line before you can add them to a conference. If calls are on different lines, transfer them to a single line before using **Confrn** or **Join**.
- Depending on how your phone is configured, if you leave a conference after creating it, the conference might end. To avoid this, transfer the conference before hanging up.

Starting or Joining a Meet-Me Conference Call

Meet-Me conferencing allows you to start or join a conference by dialing the conference number.

If you want to...	Then...
Start a Meet-Me conference	<ol style="list-style-type: none"> 1. Obtain a Meet-Me phone number from your system administrator. 2. Distribute the number to participants. 3. When you are ready to start the meeting, go off-hook to invoke a dial tone, then press MeetMe. 4. Dial the Meet-Me conference number. <p>Participants can now join the conference by dialing in.</p> <p>Note Participants hear a busy tone if they call the conference before the initiator has joined. In this case, participants must call back.</p>
Participate in a Meet-Me conference	<p>Dial the Meet-Me conference number (provided by the conference initiator).</p> <p>Note You will hear a busy tone if you call the conference before the initiator has joined. In this case, try your call again.</p>
End a Meet-Me conference	<p>All participants must hang up.</p> <p>The conference does not automatically end when the conference initiator disconnects.</p>

Advanced Call Handling

Advanced call-handling tasks involve special features that your system administrator might configure for your phone depending on your call-handling needs and work environment.



Speed Dialing

Speed dialing allows you to enter an index number, press a button, or select a phone screen item to place a call. Depending on configuration, your phone can support several speed-dial features:

- Speed-dial buttons
- Abbreviated Dialing
- Fast Dials



-
- Note**
- To set up speed-dial features, you must access your User Options web pages. See [Logging In to the User Options Web Pages, page 51](#).
 - To set up Fast Dials, you must have access to the Personal Directory feature. Refer to *Customizing Your Cisco Unified IP Phone on the Web*: http://www.cisco.com/univercd/cc/td/doc/product/voice/c_ipphon/index.htm
 - Alternately, your system administrator can configure speed-dial features for you.
-

If you want to...	Then...
Use speed-dial buttons	<ol style="list-style-type: none">1. Set up speed-dial buttons from your User Options web pages.2. To place a call, press  (a speed-dial button).
Use Abbreviated Dial	<ol style="list-style-type: none">1. Set up Abbreviated Dialing codes from your User Options web pages.2. To place a call, enter the Abbreviated Dialing code and press AbbrDial.
Use Fast Dial	<ol style="list-style-type: none">1. Subscribe to the Fast Dial service and set up Fast Dial codes from your User Options web pages. See Subscribing to Phone Services, page 52.2. To place a call, choose  > Fast Dial service on your phone (exact name might vary), then highlight a listing and go off-hook.

Picking Up Redirected Calls on Your Phone

Call PickUp allows you to answer a call that is ringing on a co-worker's phone by redirecting the call to your phone. You might use Call PickUp if you share call-handling with co-workers.

If you want to...	Then...
Answer a call that is ringing on another extension within your call pickup group	<ol style="list-style-type: none"> 1. Do one of the following: <ul style="list-style-type: none"> • If the PickUp softkey is available, press it. • If the PickUp softkey is not available, go off-hook to display it, then press PickUp. <p>If your phone supports auto-pickup, you are now connected to the call.</p> 2. If the call rings, press Answer to connect to the call.
Answer a call that is ringing on another extension outside of your group	<ol style="list-style-type: none"> 1. Do one of the following: <ul style="list-style-type: none"> • If the GPickUp softkey is available, press it. • If the GPickUp softkey is not available, go off-hook to display it, then press GPickUp. 2. Enter the group pickup code. <p>If your phone supports auto-pickup, you are now connected to the call.</p> 3. If the call rings, press Answer to connect to the call.
Answer a call that is ringing on another extension in your group or in an associated group	<ol style="list-style-type: none"> 1. Do one of the following: <ul style="list-style-type: none"> • If the OPickUp softkey is available, press it. • If the OPickUp softkey is not available, go off-hook to display it, then press OPickUp. <p>If your phone supports auto-pickup, you are now connected to the call.</p> 2. If the call rings, press Answer to connect to the call.

Tips

- Depending on how your phone is configured, you might receive an audio and/or visual alert about a call to your pickup group.
- Pressing **PickUp** and **GPickUp** connects to the call that has been ringing for the longest time.
- Pressing **OPickUp** connects you to the call in the pickup group with the highest priority.
- If you have multiple lines and want to pick up the call on a non-primary line, first press  for the desired line, then press a Call PickUp softkey.

Using a Shared Line

Your system administrator might ask you to use a shared line if you:

- Have multiple phones and want one phone number
- Share call-handling tasks with co-workers
- Handle calls on behalf of a manager

Understanding Shared Lines

Remote-in-Use Icon

The remote-in-use icon  appears when another phone that shares your line has a connected call. You can place and receive calls as usual on the shared line, even when the remote-in-use icon appears.

Sharing Call Information and Barging

Phones that share a line each display information about calls that are placed and received on the shared line. This information might include caller ID and call duration. (See [Privacy](#), page 36 for exceptions.)

When call information is visible in this way, you and coworkers who share a line can add yourselves to calls using either **Barge** or **cBarge**. See [Adding Yourself to a Shared-Line Call](#), page 36.

Privacy



If you do not want co-workers who share your line to see information about your calls, enable the Privacy feature. Doing so also prevents co-workers from barging your calls. See [Preventing Others from Viewing or Joining a Shared-Line Call](#), page 37.



Note The maximum number of calls that a shared line supports can vary by phone.

Adding Yourself to a Shared-Line Call

Depending on how your phone is configured, you can add yourself to a call on a shared line using either **Barge** or **cBarge**.

If you want to...	Then...
See if the shared line is in use	Look for the remote-in-use icon  next to a line button  .
Add yourself to a call on a shared line using the Barge softkey	<ol style="list-style-type: none">1. Highlight a remote-in-use call.2. Press Barge. (You may need to press the more softkey to display Barge.) Other parties hear a beep tone announcing your presence.







If you want to...	Then...
Add yourself to a call on a shared line using the cBarge softkey	<ol style="list-style-type: none"> <li data-bbox="419 191 811 215">1. Highlight a remote-in-use call. <li data-bbox="419 232 1204 289">2. Press cBarge. (You may need to press the more softkey to display cBarge.) <p data-bbox="462 305 1184 362">Other parties hear a tone and brief audio interruption, and call information changes on the phone screen.</p>
Add new conference participants to a call that you have barged	<p data-bbox="419 378 870 402">Barge the call using cBarge, if available.</p> <p data-bbox="419 418 1213 508">Unlike Barge, cBarge converts the call into a standard conference call, allowing you to add new participants. See Making Conference Calls, page 30.</p>
Leave a barged call	<p data-bbox="419 524 521 548">Hang up.</p> <p data-bbox="419 565 1247 621">If you hang up after using Barge, the remaining parties hear a disconnect tone and the original call continues.</p> <p data-bbox="419 638 1186 695">If you hang up after using cBarge, the call remains a conference call (provided at least three participants remain on the line).</p>

Tips

- If a phone that is using the shared line has Privacy enabled, call information and barge softkeys will not appear on the other phones that share the line.
- You will be disconnected from a call that you have joined using **Barge** if the call is put on hold, transferred, or turned into a conference call.

Preventing Others from Viewing or Joining a Shared-Line Call

If you share a phone line, you can use the Privacy feature to prevent others who share the line from viewing or barging (adding themselves to) your calls.

If you want to...	Then...
Prevent others from viewing or barging calls on a shared line	<ol style="list-style-type: none"> <li data-bbox="537 1162 780 1187">1. Press Private . <li data-bbox="537 1203 1231 1260">2. To verify that Privacy is on, look for the Privacy-enabled icon  next to the line button .
Allow others to view or barge calls on a shared line	<ol style="list-style-type: none"> <li data-bbox="537 1276 780 1300">1. Press Private . <li data-bbox="537 1317 1240 1373">2. To verify that Privacy is off, look for the Privacy-disabled icon  next to line button .





Tips

- If the phone that shares your line has Privacy enabled, you can make and receive calls using the shared line as usual.
- The Privacy feature applies to all shared lines on your phone. Consequently, if you have multiple shared lines and Privacy is enabled, coworkers will not be able to view or barge calls on any of your shared lines.

Storing and Retrieving Parked Calls

You can park a call when you want to store the call so that you or someone else can retrieve it from another phone in the Cisco Unified CallManager system (for example, a phone at a co-worker's desk or in a conference room). You can park a call by using these methods:

- **Call Park**—Use the **Park** softkey to store the call. Your phone displays the call park number where the system stored your call. You must record this number and then use the same number to retrieve the call.
- **Directed Call Park**—Use the **Transfer** softkey to direct the call to a specific directed call park number that you dial or speed dial. To retrieve the call from a directed call park number, you must dial the park retrieval prefix and then dial or speed dial the same directed call park number. You can use a Directed Call Park button to speed dial the directed call park number and to monitor whether a directed call park number is occupied or available.

If you want to...	Then...
Store an active call using Call Park	<ol style="list-style-type: none">1. During a call, press Park. (You may need to press the more softkey to see Park.)2. Note the call park number displayed on your phone screen.3. Hang up.
Retrieve a parked call	Enter the call park number from any Cisco Unified IP Phone in your network to connect to the call.
Direct and store an active call at a directed call park number	<ol style="list-style-type: none">1. During a call, press Transfer.2. Press  (Directed Call Park) with the park-unoccupied icon  to speed dial the directed call park number. The park-occupied icon  indicates that the directed call park number is not available.3. Press Transfer again to finish storing the call.
Retrieve a parked call from a directed call park number	From any phone in the network, enter the park retrieval prefix and dial the directed call park number. Or after entering the park retrieval prefix, press the  (Directed Call Park button) with the park-occupied icon  to connect to the call.

Tips



- You have a limited amount of time to retrieve a parked call before it reverts to ringing at the original number. See your system administrator for details.
- Your system administrator can assign Directed Call Park buttons to available line buttons on your Cisco Unified IP Phone 7960G or 7940G or on your Cisco Unified IP Phone Expansion Module 7914.
- You can dial directed call park numbers if you do not have Directed Call Park buttons on your phone. However, you will not be able to see the status of the directed call park number.

Making and Receiving Secure Calls

Depending on how your system administrator has configured your phone system, your phone might support making and receiving secure calls.

Your phone is capable of supporting these types of calls:

- *Authenticated* call—The identities of all phones participating in the call have been verified.
- *Encrypted* call—The phone is receiving and transmitting encrypted audio (your conversation) within the Cisco IP network. Encrypted calls are also authenticated.
- *Non-secure* call—At least one of the participating phones or the connection does not support these security features, or the phones cannot be verified.

If you want to...	Then...
Check the security level of a call	Look for a security icon in the top right corner of the call activity area, next to the call duration timer: <ul style="list-style-type: none"> <li data-bbox="561 959 825 997"> Authenticated call <li data-bbox="561 1016 780 1053"> Encrypted call Neither security icon appears if the call is non-secure.
Determine if secure calls can be made in your company	Contact your system administrator.



Note

There are interactions, restrictions, and limitations that affect how security features work on your phone. For more information, ask your system administrator.

Tracing Suspicious Calls

If you are receiving suspicious or malicious calls, your system administrator can add the Malicious Call Identification (MCID) feature to your phone. This feature enables you to identify an active call as suspicious, which initiates a series of automated tracking and notification messages.

If you want to...	Then...
Notify your system administrator about a suspicious or harassing call	Press MCID . Your phone plays a tone and displays the message, “MCID successful.”

Prioritizing Critical Calls

In some specialized environments, such as military or government offices, you might need to make and receive urgent or critical calls. If you have the need for this specialized call handling, your system administrator can add Multilevel Precedence and Preemption (MLPP) to your phone.

Keep these terms in mind:

- *Precedence* indicates the priority associated with a call.
- *Preemption* is the process of ending an existing, lower priority call while accepting a higher priority call that is sent to your phone.

If you...	Then...
Want to choose a priority (precedence) level for an outgoing call	Contact your system administrator for a list of corresponding precedence numbers for calls.
Want to make a priority (precedence) call	Enter the MLPP access number (provided by your system administrator) followed by the phone number.
Hear a special ring (faster than usual) or special call waiting tone	You are receiving a priority (precedence) call. An MLPP icon on your phone screen indicates the priority level of the call.
Want to view priority level of a call	Look for an MLPP icon on your phone screen: <ul style="list-style-type: none">■ Priority call▣ Medium priority (immediate) call▢ High priority (flash) call▣▣ Highest priority (flash override) or Executive Override call Higher priority calls are displayed at the top of your call list. If you do not see an MLPP icon, the priority level of the call is normal (routine).



If you...	Then...
Want to accept a higher-priority call	Answer the call as usual. If necessary, end an active call first.
Hear a continuous tone interrupting your call	You or the other party are receiving a call that must preempt the current call. Hang up immediately to allow the higher priority call to ring through.

Tips

- When you make or receive an MLPP-enabled call, you will hear special ring tones and call waiting tones that differ from the standard tones.
- If you enter an invalid MLPP access number, a verbal announcement will alert you of the error.
- An MLPP-enabled call retains its priority and preemptive status when you:
 - Put the call on hold
 - Transfer the call
 - Add the call to a three-way conference
 - Answer the call using PickUp

Using Cisco Extension Mobility

Cisco Extension Mobility (EM) allows you to temporarily configure a Cisco Unified IP Phone as your own. Once you log in to EM, the phone adopts your user profile, including your phone lines, features, established services, and web-based settings. Your system administrator must configure EM for you.

If you want to...	Then...
Log in to EM	<ol style="list-style-type: none"> 1. Choose  > EM Service (name can vary). 2. Enter your user ID and PIN (provided by your system administrator). 3. If prompted, select a device profile.
Log out of EM	<ol style="list-style-type: none"> 1. Choose  > EM Service (name can vary). 2. When prompted to log out, press Yes.

Tips

- EM automatically logs you out after a certain amount of time. This time limit is established by your system administrator.
- Changes that you make to your EM profile (from the User Options web pages) take effect the next time that you log in to EM on a phone.
- Settings that are controlled on the phone only are not maintained in your EM profile.

Logging Out of Hunt Groups

If your organization receives a large number of incoming calls, you might be a member of a hunt group. A hunt group includes a series of directory numbers that share the incoming call load. When the first directory number in the hunt group is busy, the system hunts for the next available directory number in the group and directs the call to that phone. When you are away from your phone, you can prevent hunt group calls from ringing your phone by logging out of hunt groups.









If you want to...	Then...
Log out of hunt groups to temporarily block hunt group calls	Press HLog . Your phone screen displays, “Logged out of Hunt Group.”
Log in to receive hunt group calls	Press HLog .

Tip

Logging out of hunt groups does not prevent non-hunt group calls from ringing your phone.

Using a Handset, Headset, and Speakerphone

You can use your phone with a handset, headset, or speakerphone.





If you want to...	Then...
Use the handset	Lift it to go off-hook; replace it to go on-hook.
Use a headset	Press  to toggle headset mode on and off. If you use AutoAnswer, see Using AutoAnswer, page 44 for exceptions. You can use the headset in conjunction with all of the controls on your phone, including  and  .
Use the speakerphone	Press  to toggle speakerphone mode on or off. Many of the actions you can take to dial a number or answer a call will automatically trigger speakerphone mode, assuming that the handset is in its cradle and  is not lit.
Switch to the speakerphone or headset (from the handset) during a call	Press  or  , then hang up the handset.
Switch to the handset (from the speakerphone or headset) during a call	Lift the handset. There is no need to push any buttons.
Adjust the volume level for a call	Press  during a call or after invoking a dial tone. This action adjust the volume for the handset, speakerphone, or headset, depending on which device is in use. Press Save to preserve the volume level for future calls.

Obtaining a Headset

Your phone supports four- or six-wire headset jacks. For information about purchasing headsets, see [Headset Information, page 14](#).

Using AutoAnswer

You might use AutoAnswer if you receive a high volume of incoming calls or handle calls on behalf of others. Your system administrator configures AutoAnswer to work with either your speakerphone or headset. See the table below for details.



If you...	Then...
Use AutoAnswer with a headset	<p>Keep headset mode active (in other words, keep  illuminated) even when you are not on a call. To keep headset mode active, press EndCall to hang up (rather than pressing  to end the call), then press NewCall or Dial when placing new calls.</p> <p>If your phone is set up to use AutoAnswer in headset mode, calls will be answered automatically only if  is lit. Otherwise, calls will ring normally and you will need to manually answer them.</p>
Use AutoAnswer with the speakerphone	<p>Keep the handset in the cradle and headset mode inactive (in other words, keep  unlit).</p> <p>If your phone is set up to use AutoAnswer in speakerphone mode, calls will be answered automatically using the speakerphone only if the above criteria are met. Otherwise, calls will ring normally and you will need to manually answer them.</p>

Using Phone Settings

You can personalize your Cisco Unified IP Phone by adjusting the ring tone, phone screen, and other settings.

Customizing Rings and Message Indicators

You can customize how your phone indicates an incoming call and a new voice mail message. You can also adjust the ringer volume for your phone.

If you want to...	Then...
Change the ring tone per line	<ol style="list-style-type: none"> 1. Choose  > Ring Type. 2. Choose a phone line or the default ring setting. 3. Choose a ring tone to play a sample of it. 4. Press Select and OK to set the ring tone, or press Cancel.
Change the ring pattern per line (flash-only, ring once, beep-only, etc.)	<ol style="list-style-type: none"> 1. Log in to your User Options web pages. (See Logging In to the User Options Web Pages, page 51.) 2. Choose Change the Ring Settings for your phone (if available.)
Adjust the volume level for the phone ringer	Press  while the handset is in the cradle and the headset and speakerphone buttons are off. The new ringer volume is saved automatically.
Change the way that the voice message light on your handset works	<ol style="list-style-type: none"> 1. Log in to your User Options web pages. (See Logging In to the User Options Web Pages, page 51.) 2. Choose Change the Message Waiting Lamp policy...

Tips

- Before you can access the “Change the Ring settings...” item from the User Options web pages, your system administrator might need to enable this option for your phone.
- Typically, the default system policy for the voice message light on your handset tells your phone to always light to indicate a new voice message.

Customizing the Phone Screen

You can adjust the contrast and the language for your phone screen.





If you want to...	Then...
Change the phone screen contrast	<ol style="list-style-type: none"><li data-bbox="366 297 1209 329">1. Choose  > Contrast.<li data-bbox="366 337 1209 370">2. Press OK to save, or press Cancel.
Change the language on your phone screen	Log in to your User Options web pages, select your device, then choose Change the Locale... from the main menu. See Logging In to the User Options Web Pages, page 51 for more information.

Using Call Logs and Directories

This section describes how you can use call logs and directories. To access both features, use the Directories button .

Using Call Logs

Your phone maintains records of your missed, placed, and received calls.

If you want to...	Then...
View your call logs	Choose  > Missed Calls, Placed Calls, or Received Calls . Each stores up to 32 records. To view a truncated listing, highlight it and press EditDial .
Erase your call logs	Press  , then press Clear . Doing so erases all call records in all logs.
Dial from a call log (while not on another call)	<ol style="list-style-type: none"> 1. Choose  > Missed Calls, Placed Calls, or Received Calls. 2. Highlight a call record from the log. 3. If you need to edit the displayed number, press EditDial followed by << or >>. To delete the number, press EditDial followed by Delete. (You may need to press the more softkey to display Delete.) 4. Go off-hook to place the call.
Dial from a call log (while connected to another call)	<ol style="list-style-type: none"> 1. Choose  > Missed Calls, Placed Calls, or Received Calls. 2. Highlight a call record from the log. 3. If you need to edit the displayed number, press EditDial followed by << or >>. To delete the number, press EditDial followed by Delete. (You may need to press the more softkey to display Delete.) 4. Press Dial. 5. Choose a menu item to handle the original call: <ul style="list-style-type: none"> • Hold—Puts the first call on hold and dials the second. • Transfer—Transfers the first party to the second and drops you from the call. (Press Trnsfer again after dialing to complete the action.) • Conference—Creates a conference call with all parties, including you. (Press Confrn again after dialing to complete the action.) • EndCall—Disconnects the first call and dials the second.

Tip

If the network shuts down or your phone resets, you might lose information in your call logs.



Directory Dialing

Depending on configuration, your phone can provide access to a corporate directory and personal directory features:

- **Corporate Directory**—Corporate contacts that you can access on your phone. Corporate Directory is set up and maintained by your system administrator
- **Personal Directory**—If available, personal contacts and associated speed-dial codes that you can configure and access from your phone and User Options web pages. Personal Directory is comprised of Personal Address Book (PAB) and Fast Dials.
 - PAB is a directory of your personal contacts.
 - Fast Dials allows you to assign codes to PAB entries for quick dialing.

Using Corporate Directory on Your Phone

You can use a corporate directory to place calls to coworkers.

If you want to...	Then...
Dial from a corporate directory (while not on another call)	<ol style="list-style-type: none">1. Choose  > Corporate Directory (exact name can vary).2. Use your keypad to enter a full or partial name and press Search.3. To dial, select the listing that you want to dial, or scroll to the listing and go off-hook.
Dial from a corporate directory (while connected to another call)	<ol style="list-style-type: none">1. Choose  > Corporate Directory (exact name can vary).2. Use your keypad to enter a full or partial name and press Search.3. Scroll to a listing and press Dial.4. Choose a menu item to handle the original call:<ul style="list-style-type: none">• Hold—Puts the first call on hold and dials the second.• Transfer—Transfers the first party to the second and drops you from the call. (Press Transfer again after dialing to complete the action.)• Conference—Creates a conference call with all parties, including you. (Press Confrn again after dialing to complete the action.)• EndCall—Disconnects the first call and dials the second.

Tip

Use the numbers on your keypad to enter characters on your phone screen. Use the Navigation button on your phone to move between input fields.

Using Personal Directory on Your Phone

The Personal Directory feature set contains your Personal Address Book (PAB) and Fast Dials. For information about how to set up and use the Personal Directory, refer to

Customizing Your Cisco Unified IP Phone on the Web:



http://www.cisco.com/univercd/cc/td/doc/product/voice/c_ipphon/index.htm

Accessing Voice Messages

To access voice messages, use the Message button .



Note Your company determines the voice message service that your phone system uses. For the most accurate and detailed information, refer to the documentation that came with your voice messaging service.

If you want to...	Then...
Set up and personalize your voice message service	Press  and follow the voice instructions. If a pop-up messages menu appears on your phone screen, choose an appropriate menu item.
See if you have a new voice message	Look at your phone for the following indicators: <ul style="list-style-type: none"><li data-bbox="353 708 1123 764">• A steady red light on your handset. (This indicator can vary. See Customizing Rings and Message Indicators, page 45.)<li data-bbox="353 773 1177 829">• A flashing message waiting icon  and text message on your phone screen.
Listen to your voice messages or access the voice messages menu	Press  . Depending on your voice message service, doing so either auto-dials your voice message service or provides a menu on your phone screen.
Send a call to your voice message system	Press iDivert . The iDivert feature automatically transfers a call (including a ringing or held call) to your voice message system. Callers will hear your voice message greeting and can leave you a message.

Accessing Your User Options Web Pages

Because your Cisco Unified IP Phone is a network device, it can share information with other network devices in your company, including your computer and web-based services accessible using a web browser on your computer.

You can establish phone services, and control settings and features from your computer using the Cisco Unified CallManager User Options web pages. Once you configure features and services on the web pages, you can access them on your phone.

For example, you can set up speed dial buttons from your web pages, then access them on your phone.

This section describes how to access your User Option web pages and how to subscribe to phone services. For more details about the features you can configure and the phone services to which you can subscribe, refer to *Customizing Your Cisco Unified IP Phone on the Web* at the following URL: http://www.cisco.com/univercd/cc/td/doc/product/voice/c_ipphon/index.htm

Logging In to the User Options Web Pages

Procedure

- Step 1** Obtain a User Options URL, user ID, and default password from your system administrator.
 - Step 2** Open a web browser on your computer and enter the URL (provided by your system administrator) and log on.
 - Step 3** From the general menu, select your device type (phone model) in the “Select a device” drop-down list.
After you make your selection, a context-sensitive menu appears with options appropriate for your device type.
-

Tips for Navigating the User Options Web Pages

- Select your device from the menu page to see all of your options.
- Click **Update** to apply and save your changes.
- Click **Return to the Menu** to get back to the context-sensitive menu.
- Click **Log Off** to exit the User pages.



Subscribing to Phone Services

Before you can access subscription phone services on your phone, you need to subscribe to them by using your computer to access the User Options web pages. See [Logging In to the User Options Web Pages, page 51](#).

Phone services can include:

- Web-based information, such as stock quotes, movie listings, and weather reports
- Network data, such as corporate calendars and searchable directories
- Phone features, such as the Fast Dial service and a Personal Address Book

Refer to the following table for more information.

If you want to...	Then do this after you log in and select your device type...
Subscribe to a service	From the main menu, choose Configure your Cisco Unified IP Phone Services . Select a service from the “Available Services” drop-down list and click Continue . Enter more information upon request (such as a zip code or PIN), then click Subscribe .
Change or end subscriptions	From the main menu, choose Configure your Cisco Unified IP Phone Services . Click a service in the “Your Subscribed Services” panel. Click Update after making changes, or click Unsubscribe .
Add a service to a programmable button	After subscribing to a service, choose Add/Update your Service URL Buttons from the main menu. For each available button, select a service from the drop-down list and enter a text description. Click Update after making your changes. Your system administrator determines how many programmable buttons are available for services and might assign service buttons to your phone.
Access a service on your phone	Press  on your phone. Or, if you have added a service to a programmable button, press the button  .
Learn how to use phone services	Refer to <i>Customizing Your Cisco Unified IP Phone on the Web</i> : http://www.cisco.com/univercd/cc/td/doc/product/voice/c_ipphon/index.htm

Understanding Additional Configuration Options

Your system administrator can configure your phone to use specific button and softkey templates along with special services and features, if appropriate. The table below provides an overview of some configuration options that you might want to discuss with your phone system administrator based on your calling needs or work environment.



Note You can locate User Guides and other documents listed in this table from the following URL: http://www.cisco.com/univercd/cc/td/doc/product/voice/c_ipphon/index.htm

If you...	Then...	For more information...
Need to handle more calls on your phone line	Ask your system administrator to configure your line to support more calls.	Talk to your system administrator or phone support team.
Need more than one phone line	Ask your system administrator to configure one or more additional directory numbers for you.	Talk to your system administrator or phone support team.
Need more speed dial buttons	First make sure that you are using all of your currently available speed dial buttons. If you need additional speed dial buttons, try using Abbreviated Dialing or subscribing to the Fast Dial service. Another option is to attach the Cisco Unified IP Phone Expansion Module 7914 to your phone.	See: <ul style="list-style-type: none"> • Speed Dialing, page 34 • Subscribing to Phone Services, page 52 • <i>Cisco Unified IP Phone Expansion Module 7914 Phone Guide</i>
Work with (or work as) an administrative assistant	Consider using: <ul style="list-style-type: none"> • The Cisco Unified CallManager Assistant service • A shared line 	See: <ul style="list-style-type: none"> • Using a Shared Line, page 36 • Cisco Unified CallManager Assistant User Guide
Want to use one extension for several phones	Request a shared line. This allows you to use one extension number for your desk phone and lab phone, for example.	See Using a Shared Line, page 36 .

If you...	Then...	For more information...
Share phones or office space with co-workers	Consider using: <ul style="list-style-type: none"> • Call Park to store and retrieve calls without using the transfer feature. • Call Pickup to answer calls ringing on another phone. • A shared line to view or join co-workers' calls. • Cisco Extension Mobility to apply your phone number and user profile to a shared phone 	Ask your system administrator about these features and see: <ul style="list-style-type: none"> • Advanced Call Handling, page 34 • Using a Shared Line, page 36 • “Using the Extension Mobility Service” in the document <i>Customizing Your Cisco Unified IP Phone on the Web</i>
Answer calls frequently or handle calls on someone's behalf	Ask your system administrator to set up the AutoAnswer feature for your phone.	See Using AutoAnswer, page 44 .
Need to make video calls	Consider using Cisco Unified Video Advantage, which enables you to make video calls using your Cisco Unified IP Phone, your personal computer, and an external video camera.	Contact your system administrator for assistance and see the <i>Cisco Unified Video Advantage User Guide</i> and <i>Cisco Unified Video Advantage Quick Start Guide</i> .
Want to temporarily apply your phone number and settings to a shared Cisco Unified IP Phone	Ask your system administrator about the Cisco Extension Mobility service.	See the “Using the Extension Mobility Service” section in <i>Customizing Your Cisco Unified IP Phone on the Web</i> .

Troubleshooting Your Phone

This section provides troubleshooting information for your Cisco Unified IP Phone.





General Troubleshooting

This section provides information to help you troubleshoot general problems with your phone. For more information, see your system administrator.

Symptom	Explanation
You cannot hear a dial tone or complete a call	One or more of the following factors might apply: <ul style="list-style-type: none"> You must log into the Extension Mobility service. You must enter a client matter code or forced authorization code after dialing a number. Your phone has time-of-day restrictions that prevent you from using some features during certain hours of the day.
The Settings button is unresponsive	Your system administrator might have disabled  on your phone.
The softkey that you want to use does not appear	One or more of the following factors might apply: <ul style="list-style-type: none"> You must press more to reveal additional softkeys. You must change the line state (for example, go off-hook or have a connected call). Your phone is not configured to support the feature associated with that softkey.
Join fails	Join requires multiple selected calls. Be sure that you have selected at least one call in addition to the active call, which is selected automatically. Join also requires the selected calls to be on the same line. If necessary, transfer calls to one line before joining them.
Barge fails and results in a fast busy tone	You cannot barge an encrypted call if the phone you are using is not configured for encryption. When your barge attempt fails for this reason, your phone plays a fast busy tone.
You are disconnected from a call that you joined using Barge	You will be disconnected from a call that you have joined using Barge if the call is put on hold, transferred, or turned into a conference call.
Cisco CallBack fails	The other party might have call forwarding enabled.

Viewing Phone Administration Data

Your system administrator might ask you to access administration data on your phone for troubleshooting purposes.

If you are asked to...	Then...
Access network configuration data	Choose  > Network Configuration and select the network configuration item that you want to view.
Access status data	Choose  > Status and select the status item that you want to view.
Access phone model information	Choose  > Model Information .
Access phone call and voice quality information	Choose  > Status > Call Statistics .

Using the Quality Reporting Tool

Your system administrator may temporarily configure your phone with the Quality Reporting Tool (QRT) to troubleshoot performance problems. You can press **QRT** to submit information to your system administrator. Depending on configuration, use the QRT to:

- Immediately report an audio problem on the current call
- Select a general problem from a list of categories and choose reason codes

Cisco One-Year Limited Hardware Warranty Terms

There are special terms applicable to your hardware warranty and various services that you can use during the warranty period. Your formal Warranty Statement, including the warranty applicable to Cisco software, is included on the Cisco Documentation CD and on Cisco.com. Follow these steps to access and download the *Cisco Information Packet* and your warranty document from the CD or Cisco.com.

1. Launch your browser, and go to this URL:

http://www.cisco.com/univercd/cc/td/doc/es_inpkc/cetrans.htm

The Warranties and License Agreements page appears.

2. To read the *Cisco Information Packet*, follow these steps:

- a. Click the **Information Packet Number** field, and make sure that the part number 78-5235-03B0 is highlighted.
- b. Select the language in which you would like to read the document.
- c. Click **Go**.
- d. The Cisco Limited Warranty and Software License page from the Information Packet appears.
- e. Read the document online, or click the **PDF** icon to download and print the document in Adobe Portable Document Format (PDF).



Note

You must have Adobe Acrobat Reader to view and print PDF files. You can download the reader from Adobe's website: <http://www.adobe.com>

3. To read translated and localized warranty information about your product, follow these steps:
 - a. Enter this part number in the Warranty Document Number field:
78-10747-01C0
 - b. Select the language in which you would like to view the document.
 - c. Click **Go**.
The Cisco warranty page appears.
 - d. Read the document online, or click the **PDF** icon to download and print the document in Adobe Portable Document Format (PDF).

You can also contact the Cisco service and support website for assistance:

http://www.cisco.com/public/Support_root.shtml.

Duration of Hardware Warranty

One (1) Year

Replacement, Repair, or Refund Policy for Hardware

Cisco or its service center will use commercially reasonable efforts to ship a replacement part within ten (10) working days after receipt of a Return Materials Authorization (RMA) request. Actual delivery times can vary, depending on the customer location.

Cisco reserves the right to refund the purchase price as its exclusive warranty remedy.

To Receive a Return Materials Authorization (RMA) Number

Contact the company from whom you purchased the product. If you purchased the product directly from Cisco, contact your Cisco Sales and Service Representative.

Complete the information below, and keep it for reference.

Company product purchased from	
Company telephone number	
Product model number	
Product serial number	
Maintenance contract number	



Index

A

- accessibility features [12](#)
- answering calls [25](#)
- authenticated calls [39](#)
- AutoAnswer, using [44](#)

B

- barge
 - and privacy [37](#)
 - and shared lines [36](#)
 - using [36](#)

C

- call activity area, viewing [19](#)
- call forwarding [29](#)
- call logs
 - erasing [47](#)
 - viewing and dialing from [47](#)
- call overview mode [28](#)
- call park [38](#)
- call priority
 - precedence [40](#)
 - preemption [40](#)
- call waiting [25](#)
- CallBack [24](#)

- caller ID [20](#)
- call-handling, advanced [34](#)
- call-handling, basic [23](#)
- calls
 - answering [25](#)
 - compared to lines [21](#)
 - conference features for [30](#)
 - ending [26](#)
 - forwarding [29](#)
 - handling multiple [27](#)
 - holding and resuming [26](#)
 - icons for [21](#)
 - multiple parties on [30](#)
 - muting [27](#)
 - parking [38](#)
 - placing [23, 24](#)
 - prioritizing [40](#)
 - redirecting while ringing [25](#)
 - secure [39](#)
 - selecting [21](#)
 - storing and retrieving [38](#)
 - transferring [28](#)
 - viewing [19, 28](#)
- cBarge
 - See also barge
 - using [36](#)

- Cisco Unified IP Phone
 - adjusting height of [14](#)
 - connecting [13](#)
 - description of [16](#)
 - documentation for [2](#)
 - feature configuration for [20, 22, 53](#)
 - illustration of [17](#)
 - online help for [21](#)
 - registering [14](#)
 - securing handset rest [14](#)
 - web-based services for [51](#)
- conference calls
 - Meet-Me [31, 33](#)
 - standard [30, 31](#)
- corporate directory
 - dialing from web page with [24](#)

D

- dialing, options for [23, 24](#)
- directed call park [38](#)
- directories button, description of [18](#)
- directory
 - dialing from web page with [24](#)
 - using on phone [47](#)
- documentation, accessing [2](#)

E

- encrypted calls [39](#)
- ending a call, options for [26](#)
- Extension Mobility
 - log in [41](#)

- log out [41](#)
- using [41](#)
- extension numbers, viewing [19](#)

F

- Fast Dial service
 - dialing with [24](#)
 - subscribing to [52](#)
- feature buttons
 - directories [18](#)
 - help [18](#)
 - messages [18](#)
 - services [18](#)
 - settings [18](#)
- features, availability of [20, 22](#)
- footstand
 - adjusting [14](#)
 - button, identifying [18](#)
- forwarding calls, options for [29](#)

H

- handset
 - light strip [17](#)
 - securing in cradle [14](#)
 - using [43](#)
 - volume [45](#)
- hanging up, options for [26](#)
- headset
 - answering calls with [25](#)
 - button, identifying [18](#)
 - hanging up with [26](#)

- mode, using [43](#)
- placing calls with [23](#)
- volume [45](#)
- headset performance, general [14](#)
- help button [28](#)
- help button, description of [18](#)
- help, using [21](#)
- hold
 - and switching calls [27](#)
 - and transferring [28](#)
 - resuming call [26](#)
 - resuming call from different line [26](#)
 - reverting call indicators [26](#)
 - using [26](#)
- hold reversion [26](#)
 - indicators [26](#)
- hunt group
 - description of [42](#)
 - log out [42](#)

I

- icons, for call states [21](#)
- installing, Cisco Unified IP Phone [13](#)

K

- keypad, description of [19](#)

L

- line buttons, identifying [18](#)

- lines
 - description of [21](#)
 - viewing [19](#)
- log out of hunt groups [42](#)

M

- Malicious Call Identification (MCID) [40](#)
- Meet-Me conferences [31, 33](#)
- messages button, description of [18](#)
- missed calls, records of [47](#)
- MLPP
 - access number [40](#)
 - icons [40](#)
 - using [40](#)
- Multilevel Precedence and Preemption (MLPP) [40](#)
- multiple calls, handling [27](#)
- mute button, description of [18](#)
- mute, using [27](#)

N

- navigation button, description of [19](#)
- network configuration data, locating [55](#)

O

- on-hook dialing [23](#)
- online help, using [21](#)

P

Personal Address Book (PAB)

dialing from [24](#)

subscribing to [52](#)

phone lines

buttons for [18](#)

description of [21](#)

viewing [19](#)

phone screen

adjusting contrast of [46](#)

changing language of [46](#)

cleaning [20](#)

features of [19](#)

placed calls, records of [47](#)

placing calls, options for [23, 24](#)

Precedence call priority [40](#)

pre-dial [23](#)

Preemption call priority [40](#)

prioritizing calls [40](#)

privacy

and shared lines [36](#)

using [37](#)

programmable buttons

description of [18](#)

labels for [19](#)

R

received calls, records of [47](#)

redial [23](#)

remote-in-use icon for shared lines [36](#)

resume, using [26](#)

resuming held calls [26](#)

ringer

indicator for [17](#)

volume [45](#)

S

safety, warnings [2](#)

secure calls [39](#)

selecting calls [21](#)

services button, description of [18](#)

services, subscribing to [52](#)

settings button, description of [18](#)

shared lines

and remote-in-use icon [36](#)

description of [36](#)

with barge [36](#)

with privacy [37](#)

softkey buttons

description of [19](#)

labels for [19](#)

speakerphone

answering calls with [25](#)

button, identifying [18](#)

hanging up with [26](#)

mode, using [43](#)

placing calls with [23](#)

volume [45](#)

speed dial

buttons, configuring [34](#)

buttons, identifying [18](#)

labels [19](#)

using [24](#)

- status data, locating [55](#)
- status line, viewing [19](#)
- suspicious calls, tracing [40](#)
- switching calls [27](#)

T

- TAPS, using [14](#)
- text, entering on phone [21](#)
- Tool for Auto-Registered Phones Support [14](#)
- transferring, options for [28](#)
- troubleshooting, data for [55](#)

U

- User Options web pages
 - accessing [51](#)
 - and phone services [52](#)

V

- volume
 - adjusting [45](#)
- volume button, description of [18](#)

W

- warnings, safety [2](#)
- WebDialer [24](#)



Corporate Headquarters

Cisco Systems, Inc.
170 West Tasman Drive
San Jose, CA 95134-1706
USA

www.cisco.com
Tel: 408 526-4000
800 553-NETS (6387)
Fax: 408 526-4100

European Headquarters

Cisco Systems International BV
Haarlerbergpark
Haarlerbergweg 13-19
1101 CH Amsterdam
The Netherlands

www-europe.cisco.com
Tel: 31 0 20 357 1000
Fax: 31 0 20 357 1100

Americas Headquarters

Cisco Systems, Inc.
170 West Tasman Drive
San Jose, CA 95134-1706
USA

www.cisco.com
Tel: 408 526-7660
Fax: 408 527-0883

Asia Pacific Headquarters

Cisco Systems, Inc.
168 Robinson Road
#28-01 Capital Tower
Singapore 068912

www.cisco.com
Tel: +65 6317 7777
Fax: +65 6317 7799

Cisco Systems has more than 200 offices in the following countries. Addresses, phone numbers, and fax numbers are listed on the **Cisco Website at www.cisco.com/go/offices**

Argentina • Australia • Austria • Belgium • Brazil • Bulgaria • Canada • Chile • China PRC • Colombia • Costa Rica • Croatia • Cyprus • Czech Republic • Denmark • Dubai, UAE
Finland • France • Germany • Greece • Hong Kong SAR • Hungary • India • Indonesia • Ireland • Israel • Italy • Japan • Korea • Luxembourg • Malaysia • Mexico
The Netherlands • New Zealand • Norway • Peru • Philippines • Poland • Portugal • Puerto Rico • Romania • Russia • Saudi Arabia • Scotland • Singapore
Slovakia • Slovenia • South Africa • Spain • Sweden • Switzerland • Taiwan • Thailand • Turkey • Ukraine • United Kingdom • United States • Venezuela • Vietnam • Zimbabwe

CCSP, CCVP, the Cisco Square Bridge logo, Follow Me Browsing, and StackWise are trademarks of Cisco Systems, Inc.; Changing the Way We Work, Live, Play, and Learn, and iQuick Study are service marks of Cisco Systems, Inc.; and Access Registrar, Aironet, BPX, Catalyst, CCDA, CCDP, CCIE, CCIP, CCNA, CCNP, Cisco, the Cisco Certified Internetwork Expert logo, Cisco IOS, Cisco Press, Cisco Systems, Cisco Systems Capital, the Cisco Systems logo, Cisco Unity, Enterprise/Solver, EtherChannel, EtherFast, EtherSwitch, Fast Step, FormShare, GigaDrive, GigaStack, HomeLink, Internet Quotient, IOS, IP/TV, iQ Expertise, the iQ logo, iQ Net Readiness Scorecard, LightStream, Linksys, MeetingPlace, MGX, the Networkers logo, Networking Academy, Network Registrar, Packet, PIX, Post-Routing, Pre-Routing, ProConnect, RateMUX, ScriptShare, SlideCast, SMARTnet, The Fastest Way to Increase Your Internet Quotient, and TransPath are registered trademarks of Cisco Systems, Inc. and/or its affiliates in the United States and certain other countries.

All other trademarks mentioned in this document or Website are the property of their respective owners. The use of the word partner does not imply a partnership relationship between Cisco and any other company. (0601R)

© 2006 Cisco Systems, Inc. All rights reserved.