



















Cisco Unified IP Phone 7931G Phone Guide for Cisco Unified Communications Manager 6.0 (SCCP)

Americas Headquarters

Cisco Systems, Inc.
170 West Tasman Drive
San Jose, CA 95134-1706
USA
<http://www.cisco.com>
Tel: 408 526-4000
800 553-NETS (6387)
Fax: 408 527-0883

Common Phone Tasks

View online help on phone	Press  () >  .
Place a call	Press  and enter a number.
Redial a number	Press  .
Use a headset	Press  ().
Mute your phone	Press  .
Hold a call	Press  .
Resume a call	Press  (flashing).
Transfer a call to new number	Press  .
Place an intercom call	Press  ().
Speed dial a number	Press  ().
Initiate a conference call	Press  ().



Cisco, Cisco Systems, and the Cisco Systems logo are registered trademarks or trademarks of Cisco Systems, Inc. and/or its affiliates in the United States and certain other countries. All other trademarks mentioned in this document or Website are the property of their respective owners. The use of the word partner does not imply a partnership relationship between Cisco and any other company. (0610R)

© 2007 Cisco Systems, Inc. All rights reserved.

OL-12546-01



QUICK REFERENCE



Cisco Unified IP Phone 7931G for Cisco Unified Communications Manager 6.0 (SCCP)

Softkey Definitions

Phone Screen Icons

Button Icons

Common Phone Tasks













Softkey Definitions

AbbrDial	Dial using a speed dial index number
Answer	Answer a call
Back	Return to the previous Help topic
CallBack	Receive notification when a busy extension becomes available
Cancel	Cancel an action or exit a screen without applying changes
Clear	Delete records or settings
Close	Close the current window
Confrn	Create a conference call
ConfList	View conference participants
Delete	Remove characters to the right of the cursor when using EditDial
Details	Open the Details record for a multiparty call in the Missed Calls and Received Calls logs
Dial	Dial a phone number
iDivert	Divert or redirect a call to a voice message system
DND	Turn on/off Do Not Disturb
EditDial	Edit a number in a call log
EndCall	Disconnect the current call or the current intercom call
Erase	Reset settings to their defaults
Exit	Return to the previous screen
CFwdALL	Setup/cancel call forwarding
GPickUp	Answer a call ringing in another group
Links	View related Help topics
Main	Display the Help main menu











MeetMe	Host a Meet-Me conference call
more	Display additional softkeys
NewCall	Make a new call
OPickUp	Answer a call ringing in an associated group
Park	Store a call using Call Park
PickUp	Answer a call in your group
Redial	Redial the most recently dialed number
Remove	Remove a conference participant
Resume	Resume a call on hold
RmLstC	Drop the last party added to a conference call
Save	Save the chosen settings
Search	Search for a directory listing
Select	Select a menu item or call
Transfer	Transfer a call
Update	Refresh content
VidMode	Choose a video display mode
<<	Delete entered characters
>>	Move through entered characters





Phone Screen Icons

Call State







	On-hook line
	Off-hook line
	Connected call
	Call Forwarding enabled
	Ringing call
	Call on hold
	Hold Reversion
	Remote-in-use
	Authenticated call
	Encrypted call
	Idle intercom line
	One-way intercom call
	Two-way intercom call

Feature Access

	Application menu
	Settings menu
	Directories menu
	Messages menu
	Services menu
	Headset button
	Conference button
	Other call features
	Mobility
	Feature enabled
	Feature disabled

	Speed dial button
Audio or Video Mode	
	Handset in use
	Speakerphone in use
	Headset in use
	Video

Button Icons

	Redial
	Transfer
	Hold
	Navigation and Select
	Speaker
	Mute

Contents

Getting Started 1

- Using this Guide 1
- Finding Additional Information 2
- Safety and Performance Information 2
- Cisco Product Security Overview 3
- Accessibility Features 3

Connecting Your Phone 4

An Overview of Your Phone 7

- Understanding Buttons and Hardware 7
- Understanding Lines and Calls 10
 - Understanding Line and Call Icons 11
- Understanding Phone Screen Features 12
- Accessing the Application Menu 14
- Accessing the Help System on Your Phone 14
- Understanding Feature Availability 14

Basic Call Handling 16

- Placing a Call—Basic Options 16
- Placing a Call—Additional Options 17
- Answering a Call 18
- Ending a Call 19
- Using Hold and Resume 20
- Using Mute 21
- Switching Between Multiple Calls 21
- Switching an In-Progress Call to Another Phone 21

Transferring Calls	22
Sending a Call to a Voice Message System	23
Forwarding All Calls to Another Number	24
Using Do Not Disturb	25
Making Conference Calls	26
Understanding Types of Conference Calls	26
Starting and Joining a Standard Conference	26
Starting or Joining a Meet-Me Conference Call	28
Placing or Receiving Intercom Calls	28
Advanced Call Handling	30
Speed Dialing	30
Picking Up a Redirected Call on Your Phone	31
Storing and Retrieving Parked Calls	32
Logging Out of Hunt Groups	33
Using a Shared Line	34
Understanding Shared Lines	34
Working with Shared Lines	34
Using BLF to Determine a Line State	35
Making and Receiving Secure Calls	36
Tracing Suspicious Calls	36
Prioritizing Critical Calls	37
Using Cisco Extension Mobility	38
Managing Business Calls Using a Single Phone Number	39
Using a Handset, Headset, and Speakerphone	41
Obtaining a Headset	42
Using AutoAnswer	42
Changing Phone Settings	43
Customizing Rings and Message Indicators	43
Customizing the Phone Screen	44

Using Call Logs and Directories 45

Using Call Logs 45

Directory Dialing 47

Using Corporate Directory on Your Phone 47

Using Personal Directory on Your Phone 48

Accessing Voice Messages 51

Using the User Options Web Pages 52

Accessing Your User Options Web Pages 52

Configuring Features and Services on the Web 53

Using Personal Directory on the Web 53

Setting Up Speed Dials on the Web 55

Setting Up Phone Services on the Web 56

Controlling User Settings on the Web 57

Controlling Line Settings on the Web 58

Setting Up Phones and Access Lists for Mobile Connect 60

Understanding Additional Configuration Options 63

Troubleshooting Your Phone 65

General Troubleshooting 65

Viewing Phone Administration Data 66



Cisco One-Year Limited Hardware Warranty Terms 67

Index 69

Getting Started

Using this Guide

This guide provides you with an overview of the features available on your phone. You can read it completely for a solid understanding of your phone's capabilities or refer to the table below for pointers to commonly used sections.

If you want to...	Then
Explore your phone on your own	Press  () >  on the phone when you need assistance.
Review important safety information	See Safety and Performance Information, page 2 .
Connect your phone	See Connecting Your Phone, page 4 .
Use your phone after it is installed	See An Overview of Your Phone, page 7 .
Learn about the buttons and softkeys	See Understanding Buttons and Hardware, page 7 .
Make calls	See Placing a Call—Basic Options, page 16 .
Put calls on hold	See Using Hold and Resume, page 20 .
Mute calls	See Using Mute, page 21 .
Transfer calls	See Transferring Calls, page 22 .
Make conference calls	See Making Conference Calls, page 26 .
Set up speed dialing	See Speed Dialing, page 30 .
Share a phone number	See Picking Up a Redirected Call on Your Phone, page 31 .
User your phone as a speakerphone	See Using a Handset, Headset, and Speakerphone, page 41 .
Change the ring or call volume	See Customizing Rings and Message Indicators, page 43 .
View your missed calls	See Using Call Logs, page 45 .
Listen to your voice messages	See Accessing Voice Messages, page 51 .
See softkey and icon definitions	Refer to the Quick Reference Card in the front of this guide.

Finding Additional Information

You can access the most current Cisco Unified IP Phone documentation on the World Wide Web at this URL:

http://www.cisco.com/en/US/products/hw/phones/ps379/tsd_products_support_series_home.html

You can access the Cisco website at this URL:

<http://www.cisco.com/>

International Cisco websites can be accessed from this URL:

http://www.cisco.com/public/countries_languages.shtml

Safety and Performance Information

Refer to these sections for information about the impact of power outages and other devices on your Cisco Unified IP Phone.

Power Outage

Your accessibility to emergency service through the phone is dependent on the phone being powered. If there is an interruption in the power supply, Service and Emergency Calling Service dialing will not function until power is restored. In the case of a power failure or disruption, you may need to reset or reconfigure equipment before using the Service or Emergency Calling Service dialing.

Using External Devices

The following information applies when you use external devices with the Cisco Unified IP Phone:

Cisco recommends the use of good quality external devices (such as headsets) that are shielded against unwanted radio frequency (RF) and audio frequency (AF) signals.

Depending on the quality of these devices and their proximity to other devices such as mobile phones or two-way radios, some audio noise may still occur. In these cases, Cisco recommends that you take one or more of the following actions:

- Move the external device away from the source of the RF or AF signals.
- Route the external device cables away from the source of the RF or AF signals.
- Use shielded cables for the external device, or use cables with a better shield and connector.
- Shorten the length of the external device cable.
- Apply ferrites or other such devices on the cables for the external device.

Cisco cannot guarantee the performance of the system because Cisco has no control over the quality of external devices, cables, and connectors. The system will perform adequately when suitable devices are attached using good quality cables and connectors.

**Caution**

In European Union countries, use only external speakers, microphones, and headsets that are fully compliant with the EMC Directive [89/336/EC].

Cisco Product Security Overview

This product contains cryptographic features and is subject to United States and local country laws governing import, export, transfer and use. Delivery of Cisco cryptographic products does not imply third-party authority to import, export, distribute or use encryption. Importers, exporters, distributors and users are responsible for compliance with U.S. and local country laws. By using this product you agree to comply with applicable laws and regulations. If you are unable to comply with U.S. and local laws, return this product immediately.

A summary of U.S. laws governing Cisco cryptographic products may be found at: <http://www.cisco.com/wwl/export/crypto/tool/stqrg.html>. If you require further assistance please contact us by sending email to export@cisco.com.

Accessibility Features

A list of accessibility features is available upon request.

Connecting Your Phone

Your system administrator will likely connect your new Cisco Unified IP Phone to the corporate IP telephony network. If that is not the case, refer to the graphic and table below to connect your phone.

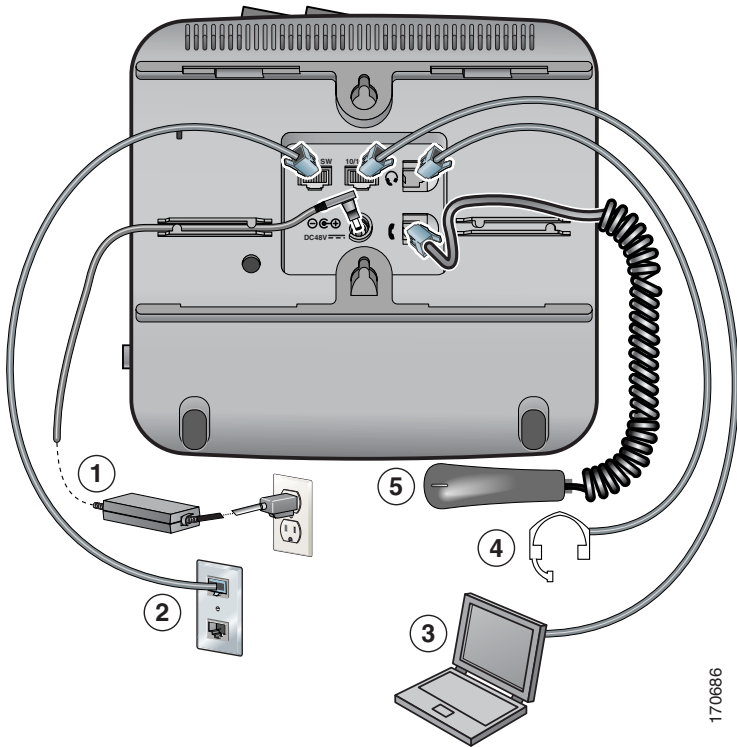

170686

1	DC Adaptor port (DC48V) (optional)
2	Network port (10/100 SW)
3	Access port (10/100 PC)
4	Headset port
5	Handset port

Adjusting the Handset Rest

When you connect your phone, you might want to adjust the handset rest to ensure that the receiver will not slip out of the cradle. See the table below for instructions.

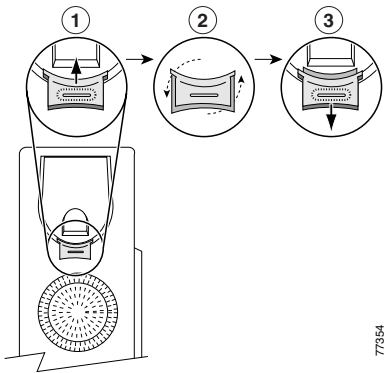

77354

1	Set the handset aside and pull the square plastic tab from the handset rest.
2	Rotate the tab 180 degrees.
3	Slide the tab back into the handset rest. An extension protrudes from the top of the rotated tab. Return the handset to the handset rest.

Registering with TAPS

After your phone is connected to the network, your system administrator might ask you to auto-register your phone using TAPS (Tool for Auto-Registered Phones Support). TAPS might be used either for a new phone or to replace an existing phone.

To register with TAPS, pick up the handset, enter the TAPS extension provided by your system administrator, and follow the voice prompts. You might need to enter your entire extension, including the area code. After your phone displays a confirmation message, hang up. The phone will re-start.

Headset Information

To use a headset, connect it to the headset port on the back of your phone. See [Using a Handset, Headset, and Speakerphone, page 41](#) for details.

Although Cisco Systems performs some internal testing of third-party headsets for use with the Cisco Unified IP Phones, Cisco does not certify or support products from headset or handset vendors. Because of the inherent environmental and hardware inconsistencies in the locations where Cisco Unified IP Phones are deployed, there is not a single “best” solution that is optimal for all environments. Cisco recommends that customers test the headsets that work best in their environment before deploying a large number of units in their network.

In some instances, the mechanics or electronics of various headsets can cause remote parties to hear an echo of their own voice when they speak to Cisco Unified IP Phone users.

Cisco Systems recommends the use of good quality external devices, like headsets that are screened against unwanted radio frequency (RF) and audio frequency (AF) signals. Depending on the quality of these devices and their proximity to other devices such as cell phones and two-way radios, some audio noise may still occur. See [Audio Quality Subjective to the User, page 6](#), for more information.

The primary reason that support of a headset would be inappropriate for the Cisco Unified IP Phone is the potential for an audible hum. This hum can either be heard by the remote party or by both the remote party and you, the Cisco Unified IP Phone user. Some potential humming or buzzing sounds can be caused by a range of outside sources, for example, electric lights, being near electric motors, large PC monitors. In some cases, a hum experienced by a user may be reduced or eliminated by using a local power cube or power injector.

Audio Quality Subjective to the User

Beyond the physical, mechanical and technical performance, the audio portion of a headset must sound good to you (the user) and to the party on the far end. Sound is subjective and Cisco cannot guarantee the performance of any headsets or handsets, but some of the headsets and handsets on the sites listed below have been reported to perform well with Cisco Unified IP Phones.

Nevertheless, it is ultimately still the customer's responsibility to test this equipment in their own environment to determine suitable performance.

For information about headsets, see:

<http://www.vxicorp.com/cisco>

<http://www.plantronics.com/cisco>

<http://www.jabra.com>

An Overview of Your Phone

The Cisco Unified IP Phone 7931G is a full-feature telephone that provide voice communication over the same data network that your personal computer uses, allowing you to place and receive phone calls, put calls on hold, transfer calls, make conference calls, and so on.







The Cisco Unified IP Phone 7931G is designed to meet the communication needs with moderate telephone traffic and specific call requirements. It provides you with dedicated hold, redial, and transfer keys to facilitate call handling. In addition to basic call-handling features, your Cisco Unified IP Phone provides enhanced productivity features that extend your call-handling capabilities:







- Access to network data, XML applications, and web-based services.
- Online customizing of phone features and services from your User Options web pages.
- A comprehensive online help system that displays information on the phone screen.

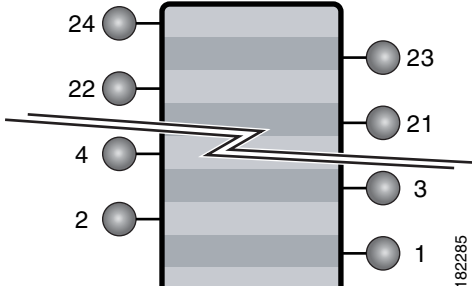



Understanding Buttons and Hardware

You can use the graphic below to identify buttons and hardware on your phone.



Feature	Description	For more information, see...
Programmable buttons 	<p>Depending on configuration, programmable buttons (or line keys) provide access to:</p> <ul style="list-style-type: none"> • Phone lines and intercom lines (line buttons) • Speed-dial numbers (speed-dial buttons, including the BLF speed-dial feature) • Web-based services (for example, a Personal Address Book button) • Call features (for example, Privacy, Conference) • Local features (for example, Application menu, Headset, Settings) <p>Buttons illuminate to indicate status:</p> <ul style="list-style-type: none">  Green, steady—Active call or two-way intercom call  Green, flashing—Held call  Amber, steady—Privacy in use, one-way intercom call, DND, logged into Hunt Group, headset or other local feature enabled  Amber, flashing—Incoming call or reverting call  Red, steady—Remote line in use (shared line, BLF status, or active Mobile Connect call)  Red, flashing—Remote call on hold <p>Line keys are numbered 24-1 in descending order, alternating from left to right.</p> 	<ul style="list-style-type: none"> • Understanding Phone Screen Features, page 12 • Basic Call Handling, page 16 • Speed Dialing, page 30 • Using a Shared Line, page 34 • Using BLF to Determine a Line State, page 35 • Placing or Receiving Intercom Calls, page 28 • Using Hold and Resume, page 20

	Feature	Description	For more information, see...
2	Paper label	Allows you to identify each button with line or feature information.	Understanding Line and Call Icons, page 11
3	Softkey buttons 	Each activates a softkey option (displayed on your phone screen).	Understanding Phone Screen Features, page 12
4	Hold button 	Places calls on hold.	Using Hold and Resume, page 20
5	Transfer button 	Connects a call to another number.	Transferring Calls, page 22
6	Redial button 	Connects to the last dialed number.	Placing a Call—Basic Options, page 16
7	Keypad	Allows you to dial phone numbers, enter letters, and choose menu items.	Basic Call Handling, page 16
8	Mute button 	Toggles the microphone on or off. When the microphone is muted, the button is lit.	Using Mute, page 21
9	Volume button 	Controls the handset, headset, and speakerphone volume (off-hook) and the ringer volume (on-hook).	Using a Handset, Headset, and Speakerphone, page 41
10	Speaker button 	Toggles the speakerphone on or off. When the speakerphone is on, the button is lit.	Using a Handset, Headset, and Speakerphone, page 41
11	Handset	Functions like a traditional handset.	Using a Handset, Headset, and Speakerphone, page 41
12	Handset indicator light	Indicates an incoming call or new voice message. Flashes for an incoming call and remains on when there is a message waiting.	Accessing Voice Messages, page 51
13	Phone screen	Displays information such as line/call status, phone number, and soft key tabs.	Understanding Phone Screen Features, page 12
14	Cisco Unified IP Phone model	Shows the Cisco Unified IP Phone model number.	

	Feature	Description	For more information, see...
15	4-way navigation pad and Select button (center) 	Navigation button <ul style="list-style-type: none"> • Scroll up and down to see menus and highlight items • Scroll left to open the Details view and see directory numbers and features assigned to each line button (when on call screen) • Scroll right to close the Details view 	Understanding Phone Screen Features, page 12
		Select button—scroll to select a line using the Navigation button, then: <ul style="list-style-type: none"> • If the button is mapped to a directory number, and: <ul style="list-style-type: none"> – The line is idle, press  to initiate a new call. – There is an on-hold call on the line, press  to resume the call. – There is an active call on the line, the Select button has no effect. • If the button is mapped to a feature, press  to access the feature. 	Understanding Phone Screen Features, page 12

Understanding Lines and Calls

To avoid confusion about lines and calls, refer to these descriptions:

- Lines—There are 24 programmable buttons (see [Understanding Buttons and Hardware, page 7](#)). Typically, your system administrator assigns some of these lines (up to 24) to be used as lines for making and receiving calls. Each corresponds to a directory number or intercom number that others can use to call you.

















Some of your lines might share the same directory number, and others might have unique directory numbers. To see your phone lines, use the Navigation button to scroll through the list of programmable button display (see [Understanding Phone Screen Features, page 12](#)).







Buttons configured as lines display their assigned directory number and associated button number. For example, if you have directory number “3105” assigned to button 1, the line appears as 3105:01 on the phone screen. Each line also has an associated icon to help you identify its purpose (see [Understanding Line and Call Icons, page 11](#)).

- Calls—Each line can support a single call. If multiple lines share a directory number, each line can still support one call each.

Understanding Line and Call Icons

Your phone displays icons to help you determine the line and call state and feature accessibility on each line.

Icon	Line or call state	Description
Call State		
	On-hook line	No call activity on this line.
	Off-hook line	You are dialing a number or an outgoing call is ringing.
	Connected call	You are connected to the other party.
	Call Forwarding enabled	Call forwarding is enabled on this line.
	Ringing call	A call is ringing on one of your lines.
	Call on hold	You have put the call on hold. See Using Hold and Resume , page 20.
	Remote-in-use	Another phone that shares your line has a connected call. See Using a Shared Line , page 34.
	Authenticated call	See Making and Receiving Secure Calls , page 36.
	Encrypted call	See Making and Receiving Secure Calls , page 36.
	Idle Intercom line	The intercom line is not in use. See Placing or Receiving Intercom Calls , page 28.
	One-way intercom	The intercom line is sending or receiving one-way audio. See Placing or Receiving Intercom Calls , page 28.
	Two-way intercom	The recipient pressed the intercom line to activate two-way audio with the caller. See Placing or Receiving Intercom Calls , page 28.
Feature Access		
	Application menu	The Application menu is assigned to this line key. See Accessing the Application Menu , page 14.
	Settings menu	The Settings menu is assigned to this line key. See Changing Phone Settings , page 43.
	Directories menu	The Directories menu is assigned to this line key. See Using Call Logs and Directories , page 45.
	Messages menu	The Messages menu is assigned to this line key. See Accessing Voice Messages , page 51.

Icon	Line or call state	Description
	Services menu	The Services menu is assigned to this line key. See Setting Up Phone Services on the Web, page 56 .
	Headset button	You can use this option to use a headset with your phone. See Using a Handset, Headset, and Speakerphone, page 41 .
	Conference button	Conference is assigned to this line key. See Making Conference Calls, page 26 .
	Other Calling feature	A call feature is assigned to this line key. Refer to the text description next to this icon to verify the feature.
	Mobility	Mobility access is assigned to this line key. See Managing Business Calls Using a Single Phone Number, page 39 .
	Feature enabled	A call feature assigned to this line key is enabled. Refer to the text description next to this icon to verify the feature.
	Speed dial or BLF speed dial button	A speed dial button is assigned to this line key. See Speed Dialing, page 30 , Setting Up Phone Services on the Web, page 56 , and Using BLF to Determine a Line State, page 35 .

Tip

To help you remember the line key assignments, your system administrator might provide you with a pre-printed paper label. If not, remove the blank one and make your own labels.

Understanding Phone Screen Features

This is what your phone screen might look like when idle. This view is called “Overview.”

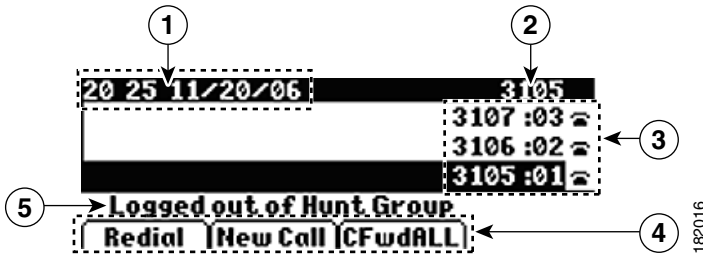

1	Date and time display	Displays the current date and time.
2	Primary phone line	Displays the phone number (directory number) for your primary phone line.
3	Programmable button indicator	Programmable buttons  can serve as phone line buttons, intercom line buttons, speed-dial buttons, phone service buttons, call feature buttons, or local feature buttons. Icons and text descriptions indicate how these buttons are configured. For an icon reference, see Understanding Line and Call Icons , page 11.
4	Softkey labels	Each displays a softkey function.
5	Status line	Displays audio mode icons, status information, and prompts.



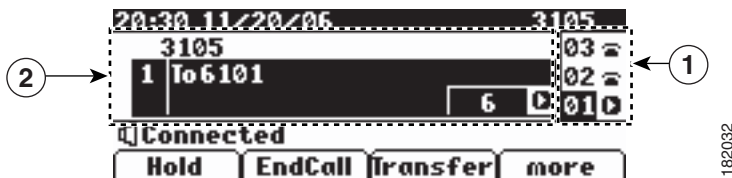

This is what your phone screen might look like when connected to a call. This view is called “Details.”



1	Overview	Displays line number and icon state for all lines.
2	Details View	Displays details about the assigned call and local features for the selected line key. In this example, information about the connected call displays, such as directory number, time connected, and call status display. Use the Navigation button to scroll and view details about other lines. Call and local features display label names and icons in their Details view (see Understanding Line and Call Icons , page 11).

Accessing the Application Menu



Use the Applications menu to access local phone features.

If you want to...	Then...
Access the Application menu	Press  >  to display a list of Applications: Messages, Directory, Settings, Services, and Help. (Typically, the Application menu is assigned to  button 24, located at the top of the left column.)
Scroll through a list or menu	Use the Navigation button.
Select a menu item	Use the Navigation button to scroll and highlight a menu item, then press  or Select . You can also press the number on the keypad that corresponds to the number for the menu item.
Go back one level in a menu	Press Exit . (If you press Exit from the top-level of a menu, the menu will close.)
Close a menu (and return to the Applications menu)	Press Exit one or more times until the menu closes.
Exit the Applications menu	Press  or Exit .

Tip

Some Application menu items (Settings, Directories, Services, Messages) can also be assigned to their own button. Use the Navigation button to scroll through the Overview and refer to [Understanding Line and Call Icons, page 11](#) to identify these lines.

Accessing the Help System on Your Phone





















Your phone provides a comprehensive online help system. To view the phone help, press  >  > **Help**. (Typically, the Application menu is assigned to  button 24, located at the top of the left column.)

Understanding Feature Availability

Depending on your phone system configuration, features included in this Phone Guide might not be available to you or might work differently on your phone. Contact your support desk or system administrator for information about feature operation or availability.

You can access features using softkeys or pressing a line key. You can configure some of these features, but your system administrator controls most of them.

Here are some details about using softkeys and line buttons to access features:







Feature	Softkey	Line Button Label and Icon
CallBack	CallBack	CallBack 
Call Forward	CFwdALL	Forward All 
Call Park	Park	Park 
Call PickUp	PickUp	PickUp 
Conference	Confrn	Conference 
Conference List	ConfList	Conference List 
Do Not Disturb	DND	Do Not Disturb 
End Call	EndCall	End Call 
Group PickUp	GPickUp	Group PickUp 
Hold	Hold	 button
Hunt Group	HLog	Hunt Group 
Malicious Call Trace	MCID	Malicious Call Trace 
Meet Me Conferencing	MeetMe	MeetMe 
Mobility	Mobility	Mobility 
New Call	New Call	New Call 
Other PickUp	OPickUp	Other PickUp 
Redial	Redial	 button
Remove Last Conference Participant	RmLstC	Remove Last Participant 
Transfer	Transfer	 button
Video Mode	VidMode	Video 

Basic Call Handling



You can perform basic call-handling tasks using a range of features and services. Feature availability can vary; see your system administrator for more information.

Placing a Call—Basic Options

Here are some easy ways to place a call on your Cisco Unified IP Phone.







If you want to...	Then...	For more information, see...
Place a call using the handset	Pick up the handset and enter a number.	Using a Handset, Headset, and Speakerphone, page 41
Place a call using the speakerphone	Press  and enter a number.	Using a Handset, Headset, and Speakerphone, page 41
Place a call using a headset	Press  () and enter a number. (Typically, button 23 is assigned to the headset.)	Using a Handset, Headset, and Speakerphone, page 41
Redial a number	Press  to dial the last number.	Placing a Call—Basic Options, page 16
Dial from a call log	<ol style="list-style-type: none">1. Press  () > Directories.2. Choose Missed Calls, Received Calls, or Placed Calls.3. Press Dial.	Using Call Logs, page 45

Tips

- You can dial on-hook, without a dial tone (pre-dial). To pre-dial, enter a number, then go off-hook by lifting the handset, pressing **Dial**, or pressing  () or .
- When you pre-dial, your phone tries to anticipate the number you are dialing by displaying matching numbers (if available) from your Placed Calls log. This is called Auto Dial. To call a number displayed with Auto Dial, scroll to it and go off-hook or press the Select button.
- If you make a mistake while dialing, press << to erase digits.
- If parties on a call hear a beep tone, the call might be monitored or recorded. Ask your system administrator for more information.

Placing a Call—Additional Options









You can place calls using special features and services that might be available on your phone. See your system administrator for more information about these additional options.

If you want to...	Then...	For more information, see...
Place a call while another call is active (using a different line)	<ol style="list-style-type: none"> 1. Press  for a new line. The first call is automatically placed on hold. 2. Enter a number. 	Using Hold and Resume, page 20
Speed dial a number	<p>Do one of the following:</p> <ul style="list-style-type: none"> • Press  (). • Use the Abbreviated Dial feature. • Use the Fast Dial feature. 	Speed Dialing, page 30
Dial from a corporate directory on your phone	<ol style="list-style-type: none"> 1. Press  () > Directories > Corporate Directory (name can vary) 2. Enter a name and press Search. 3. Highlight a listing and go off-hook. 	Using Call Logs, page 45
Use Cisco CallBack to receive notification when a busy or ringing extension is available	<ol style="list-style-type: none"> 1. Press CallBack while listening to the busy tone or ring sound. 2. Hang up. Your phone alerts you when the line is free. 3. Place the call again. 	Your system administrator
See if a line associated with a speed-dial is busy before placing a call to that line	Look for Busy Line Feature indicators.	Using BLF to Determine a Line State, page 35
Make a priority (precedence) call	Enter the MLPP access number, then enter a phone number.	Prioritizing Critical Calls, page 37
Dial from a Personal Address Book (PAB) entry	<ol style="list-style-type: none"> 1. Press  () > Directories > Personal Directory to log in. 2. Choose Personal Address Book and search for a listing. 	Using Personal Directory on Your Phone, page 48
Place a call using a billing or tracking code	<ol style="list-style-type: none"> 1. Dial a number. 2. After the tone, enter a client matter code (CMC) or a forced authorization code (FAC). 	Your system administrator

If you want to...	Then...	For more information, see...
Place a call using your Extension Mobility profile	Log in to the Extension Mobility service on a phone.	Using Cisco Extension Mobility, page 38
Make a call from a cellular phone using Mobile Voice Access	<ol style="list-style-type: none"> 1. Dial your assigned Mobile Voice access number. 2. Enter your cellular phone number (if requested) and PIN. 3. Press 1 to make a call to an enterprise IP phone. 4. Dial a desktop phone number other than your desktop phone number. <p>Note Before using Mobile Voice Access to make a call, obtain your Mobile Voice Access number and End user PIN from your system administrator.</p>	Managing Business Calls Using a Single Phone Number, page 39

Answering a Call

You can answer a call by lifting the handset, or you can use other options if they are available on your phone.

If you want to...	Then...	For more information, see...
Answer with a headset	Press  (), if unlit. Or, if  () is lit, press Answer or  (flashing).	Using a Handset, Headset, and Speakerphone, page 41
Answer with the speakerphone	Press  , Answer , or  (flashing).	Using a Handset, Headset, and Speakerphone, page 41
Switch from a connected call to answer a new call	Press Answer or, if the call is ringing on a different line, press  (flashing).	Using Hold and Resume, page 20
Answer using call waiting	Press Answer .	Using Hold and Resume, page 20
Send a call to a voice message system	Press iDivert .	Sending a Call to a Voice Message System, page 23
Auto-connect calls	Use AutoAnswer.	Using AutoAnswer, page 42
Retrieve a parked call on another phone	Use Call Park or Directed Call Park.	Storing and Retrieving Parked Calls, page 32



If you want to...	Then...	For more information, see...
Use your phone to answer a call ringing elsewhere	Use Call Pickup.	Picking Up a Redirected Call on Your Phone, page 31
Answer a priority call	Hang up the current call and press Answer .	Prioritizing Critical Calls, page 37
Answer a call on your cellular phone or other remote destination	<p>Set up Mobile Connect and answer your phone.</p> <p>When you enable Mobile Connect:</p> <ul style="list-style-type: none"> Your desktop and remote destinations receive calls simultaneously. When you answer the call on your desktop phone, the remote destinations stop ringing, are disconnected, and display a missed call message. When you answer the call on one remote destination, the other remote destinations stop ringing, are disconnected, and a missed call message is shown on the other remote destinations. 	Managing Business Calls Using a Single Phone Number, page 39

Tip



If parties on a call hear a beep tone, the call might be monitored or recorded. Ask your system administrator for more information.

Ending a Call

To end a call, simply hang up. Here are some more details.

If you want to...	Then...
Hang up while using the handset	Return the handset to its cradle. Or press EndCall .
Hang up while using a headset	Press  (). Or, to keep headset mode active, press EndCall .
Hang up while using the speakerphone	Press  or EndCall .



Using Hold and Resume





You can hold and resume calls. When you put a call on hold, the Hold icon  appears next to the line display on the phone screen, and the corresponding line button flashes green .

If another user put a shared line on hold, its associated line button displays  (flashing). You (and anyone else sharing that line) can resume the call.

If the Hold Reversion feature is enabled for your phone, calls that you leave on hold will revert back to ringing on your phone after a certain length of time. These “reverting” calls remain on hold until you resume them.

Your phone indicates the presence of a reverting call by:

- Alerting you at intervals with a single ring (or flash or beep, depending on your phone line setting).
- Briefly displaying a “Hold Reversion” message in the status bar at the bottom of the phone screen.
- Displaying the animated Hold Reversion icon  next to the caller ID for the held call.
- Displaying a line button  (flashing, depending on the line state).



If you want to...	Then...
Put a call on hold	<ol style="list-style-type: none">1. Make sure the appropriate call is highlighted.2. Press .
Remove a call from hold on the current line	<ul style="list-style-type: none">• Press  (flashing),  (flashing), or  (flashing) for the held call, or• Make sure the appropriate call is highlighted and do one of the following:<ul style="list-style-type: none">– Press Resume.– Press .

Tips

- Engaging the Hold feature typically generates music or a beeping tone.
- If you receive an alert for an incoming call and a reverting call at the same time, by default your phone will shift the focus of the phone screen to display the incoming call. Your system administrator can change this focus priority setting.
- If you use a shared line, Hold Reversion rings only on the phone that put the call on hold, not on the other phones that share the line.
- Your system administrator determines the duration between Hold Reversion alerts.



Using Mute

With Mute enabled, you can hear other parties on a call but they cannot hear you. You can use Mute with the handset, speakerphone, or a headset.

If you want to...	Then...
Toggle microphone on	Press  .
Toggle microphone off	Press  .

Switching Between Multiple Calls

You can switch between multiple calls on multiple lines.

If you want to...	Then...
Switch to a held call on another line	Press  (flashing) for the line that you are switching to.
Switch from a connected call to answer a ringing call	Press  (flashing). Any active call is placed on hold and the selected call is resumed.





Switching an In-Progress Call to Another Phone

You can switch in-progress calls between the desktop phone and your cellular phone or other remote destination.



If you want to...	Then...
Switch an in-progress call on your desktop phone to a cellular phone	<ol style="list-style-type: none"> 1. Press the Mobility softkey and select Send call to mobile. 2. Answer the in-progress call on your cellular phone. The desktop phone line button turns red  and handset icons and the calling party number appear on the phone display. You cannot use same phone line for any other calls, but if your desk phone supports multiple lines, you can use another line to make or receive calls.
Switch an in-progress call from a cellular phone to your desktop phone	<ol style="list-style-type: none"> 1. Hang up the call on your cellular phone to disconnect the cellular phone, but not the call. 2. Press Resume on your desk phone within 4 seconds and start talking on the desk phone.

Transferring Calls

Transfer redirects a connected call. The *target* is the number to which you want to transfer the call. When you transfer a call, your phone uses a new line to initiate the transfer.

If you want to...	Then...
Transfer a call without talking to the transfer recipient	<ol style="list-style-type: none"><li data-bbox="416 329 806 365">1. From an active call, press .<li data-bbox="416 370 739 406">2. Enter the target number.<li data-bbox="416 410 1169 446">3. Press  again to complete the transfer or EndCall to cancel. <p data-bbox="416 451 1209 516">Note If your phone has on-hook transfer enabled, complete the transfer by hanging up.</p>
Talk to the transfer recipient before transferring a call (consult transfer)	<ol style="list-style-type: none"><li data-bbox="416 524 806 560">1. From an active call, press .<li data-bbox="416 565 739 600">2. Enter the target number.<li data-bbox="416 605 927 641">3. Wait for the transfer recipient to answer.<li data-bbox="416 646 1169 682">4. Press  again to complete the transfer or EndCall to cancel. <p data-bbox="416 686 1209 751">Note If your phone has on-hook transfer enabled, complete the transfer by hanging up.</p>
Redirect a call to a voice message system	Press iDivert . For more information, see Sending a Call to a Voice Message System, page 23 .

Tips

- If on-hook transfer is enabled on your phone, you can either hang up to complete the call, or press  and then hang up.
- If on-hook transfer is *not* enabled on your phone, hanging up without pressing  again places the call on hold.
- You cannot use  to redirect a call on hold. Press **Resume** to remove the call from hold before transferring it.

Sending a Call to a Voice Message System

You can use **iDivert** to send an active, ringing, or on-hold call to your voice message system. Depending on the type of call and your phone configuration, you can also use **iDivert** to send the call to another party's voice message system.

- If the call was originally sent to someone else's phone, **iDivert** allows you to redirect the call either to your own voice message system or to the original called party's voice message system. Your system administrator must make this option available to you.
- If the call was sent to you directly (not transferred or forwarded to you), or if your phone does not support the option described above, using **iDivert** redirects the call to your voice message system.

If you want to...	Then...
Send an active, ringing, or on-hold call to a voice message system	Press iDivert . One of two things occurs: <ul style="list-style-type: none"> • The call is transferred to your voice message system. • Your phone screen displays a menu that allows you to choose between your voice message system or the voice message system of the original called party. Choose an option to redirect the call.

Tip

If your phone displays a menu that disappears before you make your selection, you can press **iDivert** again to re-display the menu. You can also ask your system administrator to configure a longer time-out value.

Forwarding All Calls to Another Number

You can use the Call Forward All feature to redirect incoming calls from your phone to another number.

If you want to...	Then...
Set up call forwarding on your primary line	Press CFwdALL and enter a target phone number. Note Your phone might have additional line keys assigned to the same directory number as your primary line. If so (and you want all calls to that directory number forwarded) you need to set call forwarding for each of these lines.
Cancel call forwarding on your primary line	Press CFwdALL .
Verify that call forwarding is enabled on your primary line	Look for: <ul style="list-style-type: none">• The call forward icon next to the primary phone number: , which is always on line key 1.• The call forward target number in the status line.
Set up or cancel call forwarding remotely, or for a non-primary line	<ol style="list-style-type: none">1. Log in to your User Options web pages. (See Accessing Your User Options Web Pages, page 52.)2. Access your call forwarding settings. (See Controlling Line Settings on the Web, page 58.) Note When call forwarding is enabled for any line other than the primary line, your phone does not provide you with confirmation that calls are being forwarded. Instead, you must confirm your settings in the User Options web pages.

Tips

- Enter the call forward target number exactly as you would dial it from your phone. For example, enter an access code or the area code, if necessary.
- You can forward your calls to a traditional analog phone or to another IP phone, although your system administrator might restrict the call forwarding feature to numbers within your company.
- Call forwarding is phone line specific. If a call reaches you on a line where call forwarding is not enabled, the call will ring as usual.
- Your system administrator can enable a call forward override feature that allows the person receiving your forwarded calls to reach you. With override enabled, a call placed from the target phone to your phone is not forwarded, but rings through.
- Your system administrator can change call forwarding conditions for your phone lines.

Using Do Not Disturb

You can use Do Not Disturb (DND) to block incoming calls from ringing on your phone. Your system administrator enables DND for your phone.

When DND and Call Forward All are both enabled on your phone, calls are forwarded and the caller does not hear a busy tone.

Your intercom lines still ring when DND is active.

If you want to...	Then...
Turn on DND	Press DND . “Do Not Disturb” displays on the phone, the DND lights  (solid), and the ring tone is turned off.
Turn off DND	Press DND .
Customize DND settings	<ol style="list-style-type: none"> 1. Log in to your User Options web pages. See Accessing Your User Options Web Pages, page 52. 2. Choose User Options > Device. 3. Set the following options: <ul style="list-style-type: none"> • Do Not Disturb—Turn DND on/off. • DND Incoming Call Alert—Set the alert to beep only, flash only, or disable all visible and audible alert notifications.

Making Conference Calls

Your Cisco Unified IP Phone allows you to join three or more people into one telephone conversation, creating a conference call.

Understanding Types of Conference Calls

There are two types of conference calls: Standard (ad hoc) and Meet-Me.

Standard Conference Calls

Use the **Conference** softkey to establish a standard conference by calling each participant. Standard conference calling is a default feature available on most phones.

When you make a conference call using your Cisco Unified IP Phone 7931G, your phone uses a new line to initiate the conference. Depending on how your system administrator has configured your phone, this might be a line using the same directory number as the initial call or a different one.

See [Starting and Joining a Standard Conference](#), page 26, for additional instructions.





Meet-Me Conference Calls





You can create a Meet-Me conference by calling the Meet-Me phone number at a specified time.

See [Starting or Joining a Meet-Me Conference Call](#), page 28, for additional instructions.

Starting and Joining a Standard Conference

A standard (ad hoc) conference allows at least three people to participate in a single call.

If you want to...	Then...
<ul style="list-style-type: none">• Create a conference by calling participants• Add new participants to an existing conference	<ol style="list-style-type: none">1. From a connected call, press  ().2. Enter the participant's phone number.3. Wait for the call to connect.4. Press  () again to add the participant to your call.5. Repeat to add additional participants. <p>Check with your system administrator to see if non-initiators of a conference can add or remove participants.</p>
Participate in a conference	Answer the phone when it rings.

If you want to...	Then...
View a list of conference participants	<ol style="list-style-type: none"> 1. Press  (steady) with an active conference. 2. Press ConfList. Participants are listed in the order in which they join the conference with the most recent additions at the top.
Get an updated list of conference participants	While viewing the conference list, press Update .
See who started the conference	While viewing the conference list, locate the person listed at the bottom of the list with an asterisk (*) next to the name.
Remove any conference participant	<ol style="list-style-type: none"> 1. While viewing the conference list, highlight the participant's name. 2. Press Remove.
Drop the last party added to the conference	While viewing the conference list, press RmLstC .
End your participation in a standard conference	Hang up or press EndCall .
Verify that a conference call is secure	Look for the  or  icon after “Conference” on the phone screen.
Remove a non-secure participant from a conference	While viewing the Conference List, locate the participant without the  or  icon, and press Remove . Check with your system administrator to see if non-initiators of a conference can remove participants.

Tips

- To start a secure conference, you must use a phone configured with security.
- Non-secure conferences and participants display a  icon.
- Depending on how your phone is configured, if you leave a conference after initiating it, the conference might end. To avoid this, transfer the conference before hanging up.

Starting or Joining a Meet-Me Conference Call

Meet-Me conferencing allows you to start or join a conference by calling the conference number.

If you want to...	Then...
Start a Meet-Me conference	<ol style="list-style-type: none">1. Obtain a Meet-Me phone number from your system administrator.2. Distribute the number to participants.3. When you are ready to start the meeting, go off-hook to invoke a dial tone, then press MeetMe.4. Dial the Meet-Me conference number. Participants can now join the conference by dialing in. <p>Note Participants hear a busy tone if they call the conference before the initiator has joined. In this case, participants must call back.</p>
Join a Meet-Me conference	Dial the Meet-Me conference number (provided by the conference initiator). <p>Note You will hear a busy tone if you call the conference before the initiator has joined. In this case, try your call again.</p>
End a Meet-Me conference	All participants must hang up. The conference does not automatically end when the conference initiator disconnects.

Tip

If you call a secure Meet-Me conference number from a non-secure phone, your phone displays the message, “Device Not Authorized.” For more information, see [Making and Receiving Secure Calls, page 36](#).

Placing or Receiving Intercom Calls

You can make an intercom call to a target phone that auto-answers the call in speakerphone mode with mute activated. The one-way intercom call allows you to deliver a short message to the recipient. If the recipient’s handset or headset is in use, the audio is sent to the device in use. Any current call activity that your recipient is engaged in continues simultaneously.

The target destination receives an intercom-alert tone and can then choose to:

- Listen to the caller with your microphone muted (you can hear the caller, but the caller cannot hear you).
- End the intercom call by pressing the **EndCall** softkey. Do this if you do not want to hear the message.





- Talk to the caller by pressing the active intercom button and using either the handset, headset or speaker. The intercom call becomes a two-way connection so that you can converse with the caller.

When using the intercom feature, be aware of the following:

- From an intercom line, you can only dial other intercom lines.
- You can use only one intercom line at a time.
- If you answer an intercom call while another intercom line is active, the first intercom call is dropped.
- When your active call is being monitored or recorded, you cannot receive or place intercom calls.



Note Cisco Extension Mobility does not support intercom lines.

If you want to...	Then...
Place an intercom call to a preconfigured target intercom number	Press  (intercom target line) and, after you hear the intercom-alert tone, begin speaking.
Place an intercom call to a non-preconfigured target intercom number	Press  (). Enter the intercom target number or press a speed-dial number for your target. After you hear the intercom-alert tone, begin speaking.
Receive an intercom call	When you hear the intercom-alert tone, handle the call in one of these ways: <ul style="list-style-type: none"> • Listen to the message in one-way audio. • Speak to the caller by pressing  (active intercom line). • Press EndCall.

Tips

- An intercom line can dial another intercom line only.
- Only one intercom line can be active at a time.
- If you answer an incoming call while an intercom line is active, the intercom call gets dropped.
- The intercom feature is disabled when a call is being monitored or recorded.

Advanced Call Handling

Advanced call-handling tasks involve special features that your system administrator might configure for your phone depending on your call-handling needs and work environment.



Speed Dialing

Speed dialing allows you to enter an index number, press a button, or select a phone screen item to place a call. Depending on configuration, your phone can support several speed-dial features:

- Speed-dial buttons
- Abbreviated Dialing
- Fast Dials



-
- Note**
- To set up speed-dial buttons and Abbreviated Dial, you must access your User Options web pages. See [Accessing Your User Options Web Pages, page 52](#).
 - To set up Fast Dials, you must access the Personal Directory feature. See [Using Personal Directory on Your Phone, page 48](#).
 - Alternately, your system administrator can configure speed-dial features for you.
-

If you want to...	Then...
Use speed-dial buttons	<ol style="list-style-type: none">1. Set up speed-dial buttons. See Setting Up Speed Dials on the Web, page 55.2. To place a call, press  (). <p>Note If your phone supports the Busy Lamp Field (BLF) speed-dial feature, you can see if the speed-dial number is busy before dialing. See Using BLF to Determine a Line State, page 35.</p>
Use Abbreviated Dial	<ol style="list-style-type: none">1. Set up Abbreviated Dialing codes. See Setting Up Speed Dials on the Web, page 55.2. To place a call, enter the Abbreviated Dialing code and press AbbrDial.
Use Fast Dial	<ol style="list-style-type: none">1. Create a Personal Address Book entry and assign a Fast Dials code. See Using Personal Directory on the Web, page 53.2. To place a call, access the Fast Dial service on your phone. See Using Personal Directory on the Web, page 53.

Picking Up a Redirected Call on Your Phone

Call PickUp allows you to answer a call that is ringing on a coworker's phone by redirecting the call to your phone. You might use Call PickUp if you share call-handling with coworkers.

If you want to...	Then...
<p>Answer a call that is ringing on another extension within your call pickup group</p>	<ol style="list-style-type: none"> 1. Do one of the following: <ul style="list-style-type: none"> • If the PickUp button or softkey is available, press it. • If the PickUp button or softkey is not available, go off-hook to display the PickUp softkey, then press it. <p>If your phone supports auto-pickup, you are now connected to the call.</p> 2. If the call rings, press Answer to connect to the call.
<p>Answer a call that is ringing on another extension outside of your group</p>	<ol style="list-style-type: none"> 1. Do one of the following: <ul style="list-style-type: none"> • If the Group PickUp button or GPickUp softkey is available, press it. • If the Group PickUp button or GPickUp softkey is not available, go off-hook to display the GPickUp softkey, then press it. 2. Enter the group pickup code. <p>If your phone supports auto-pickup, you are now connected to the call.</p> 3. If the call rings, press Answer to connect to the call.
<p>Answer a call that is ringing on another extension in your group or in an associated group</p>	<ol style="list-style-type: none"> 1. Do one of the following: <ul style="list-style-type: none"> • If the Other PickUp button or OPickUp softkey is available, press it. • If the Other PickUp button or OPickUp softkey is not available, go off-hook to display the OPickUp softkey, then press it. <p>If your phone supports auto-pickup, you are now connected to the call.</p> 2. If the call rings, press Answer to connect to the call.

Tips







- Depending on how your phone is configured, you might receive an audio and/or visual alert about a call to your pickup group.
- Pressing **PickUp**, **Group PickUp**, or **GPickUp** connects you to the call that has been ringing for the longest time.
- Pressing **Other PickUp** or **OPickUp** connects you to the call in the pickup group with the highest priority.
- If you have multiple lines and want to pick up the call on a non-primary line, first press  for the desired line, then press a Call PickUp button or softkey.

Storing and Retrieving Parked Calls

You can park a call when you want to store the call so that you or someone else can retrieve it from another phone in the Cisco Unified Communications Manager system (for example, a phone at a co-worker's desk or in a conference room). You can park a call by using these methods:

- **Call Park**—Use the **Park** softkey to store the call. Your phone displays the call park number where the system stored your call. You must record this number and then use the same number to retrieve the call.
- **Directed Call Park**—Use the  button to direct the call to an available directed call park number that you dial or speed dial. To retrieve the call from a directed call park number, dial the park retrieval prefix, then dial or speed dial the same directed call park number. You can use a Directed Call Park button to speed-dial the directed call park number and to monitor whether a directed call park number is occupied or available.

If you want to...	Then...
Store an active call using Call Park	<ol style="list-style-type: none">1. During a call, press Park. (You may need to press the more softkey to see Park.)2. Note the call park number displayed on your phone screen.3. Hang up.
Retrieve a parked call	Enter the call park number from any Cisco Unified IP Phone in your network to connect to the call.

If you want to...	Then...
Direct and store an active call at a directed call park number	<ol style="list-style-type: none"> 1. During a call, press . 2. Press Directed Call Park  () to speed dial the directed call park number. A Directed Call Park  (flashing) () indicates the directed call park number is not available. 3. Press Transfer again to finish storing the call.
Retrieve a parked call from a directed call park number	From any Cisco Unified IP Phone in your network, enter the park retrieval prefix and dial the directed call park number. Or after entering the park retrieval prefix, press the  (flashing) () to connect to the call.

Tips

- You have a limited time to retrieve a parked call before it reverts to ringing at the original number. See your system administrator for details.
- Your system administrator can assign Directed Call Park buttons to available line buttons on your phone.
- You can dial directed call park numbers if you do not have Directed Call Park buttons on your phone. However, you will not be able to see the status of the directed call park number.

Logging Out of Hunt Groups

If your organization receives a large number of incoming calls, you might be a member of a hunt group. A hunt group includes a series of directory numbers that share the incoming call load. When the first directory number in the hunt group is busy, the system hunts for the next available directory number in the group and directs the call to that phone.

When you are away from your phone, you can prevent hunt group calls from ringing your phone by logging out of hunt groups.

If you want to...	Then...
Log out of hunt groups to temporarily block hunt group calls	Press HLog . Your phone screen displays, “Logged out of Hunt Group.”
Log in to receive hunt group calls	Press HLog . When logged in, the Hunt Group  button is lit.

Tip

Logging out of hunt groups does not prevent non-hunt group calls from ringing your phone.



Using a Shared Line

Your system administrator might ask you to use a shared line if you:

- Have multiple phones and want one phone number
- Share call-handling tasks with coworkers
- Handle calls on behalf of a manager

Understanding Shared Lines

Remote-in-Use Icon

The remote-in-use icon  appears when another phone that shares your line has a connected call. You can place  and receive calls as usual on the shared line, even when the remote-in-use icon appears.

Sharing Call Information and Barging

Phones that share a line each display information about calls that are placed and received on the shared line. This information might include caller ID and call duration (See [Privacy, page 34](#) for exceptions).





If you are sharing a line with co-workers using a different model Cisco Unified IP Phone, they might be able to add (or barge) themselves to your active call on the shared line. Your phone does not typically support this feature. If you need it, contact your system administrator for assistance. Otherwise, enable privacy to prevent co-workers from joining your calls.









Privacy

If you do not want coworkers who share your line to see information about your calls, enable the Privacy feature. Doing so also prevents others who share the line from viewing or barging your calls.

Working with Shared Lines

You can view information about calls on your shared lines, retrieve a call on a shared line placed on hold by a co-worker, and prevent others from barging calls.

If you want to...	Then...
See if the shared line is in use	Look for the remote-in-use icon  next to a red line button  (steady).
View details about current calls on the shared line	Press the red line button  (steady) for the remote-in-use line. All non-private calls appear in the call activity area of the phone screen.
Retrieve a held call on a shared line	Press the red line button  (flashing) for the remote-in-use line.



If you want to...	Then...
Prevent others from viewing or barging calls on a shared line	<ol style="list-style-type: none"> 1. Press Private  (). 2. To verify that Privacy is on, look for the feature-enabled icon  next to an amber line button .
Allow others to view or barge calls on a shared line	<ol style="list-style-type: none"> 1. Press Private  (). 2. To verify that Privacy is off, look for the feature-disabled icon  next to an unlit line button .

Tips

- If the phone that shares your line has Privacy enabled, you can make and receive calls using the shared line as usual.
- The Privacy feature applies to all shared lines on your phone. Consequently, if you have multiple shared lines and Privacy is enabled, coworkers cannot view or barge calls on any of your shared lines.

Using BLF to Determine a Line State

Depending on configuration, you can use the Busy Lamp Field (BLF) feature to determine the state of a phone line associated with a speed-dial button listing on your phone. You can place a call to this line, regardless of the BLF status. This feature does not prevent dialing.



If you want to...	Then...
See the state of a speed-dial line	Look for one of these indicators next to the line number: <ul style="list-style-type: none">  Line is in-use.  Line is idle.

Making and Receiving Secure Calls

Depending on how your system administrator has configured your phone system, your phone might support making and receiving secure calls.

Your phone can support these types of calls:

- *Authenticated* call—The identities of all phones participating in the call have been verified.
- *Encrypted* call—The phone is receiving and transmitting encrypted audio (your conversation) within the Cisco IP network. Encrypted calls are also authenticated.
- *Non-secure* call—At least one of the participating phones or the connection does not support these security features, or the phones cannot be verified.

If you want to...	Then...
Check the security level of a call or conference	Look for a security icon in the top right corner of the call activity area, next to the call duration timer: <ul style="list-style-type: none"> Authenticated call or conference Encrypted call or conference Non-secure call or conference
Determine if secure calls can be made in your company	Contact your system administrator.



Note There are interactions, restrictions, and limitations that affect how security features work on your phone. For more information, ask your system administrator.

Tracing Suspicious Calls

If you are receiving suspicious or malicious calls, your system administrator can add the Malicious Call Identification (MCID) feature to your phone. This feature enables you to identify an active call as suspicious, which initiates a series of automated tracking and notification messages.

If you want to...	Then...
Notify your system administrator about a suspicious or harassing call	Press MCID . Your phone plays a tone and displays the message, “MCID successful.”

Prioritizing Critical Calls

In some specialized environments, such as military or government offices, you might need to make and receive urgent or critical calls. If you have the need for this specialized call handling, your system administrator can add Multilevel Precedence and Preemption (MLPP) to your phone.

Keep these terms in mind:

- *Precedence* indicates the priority associated with a call.
- *Preemption* is the process of ending an existing, lower priority call while accepting a higher priority call that is sent to your phone.

If you...	Then...
Want to choose a priority (precedence) level for an outgoing call	Contact your system administrator for a list of corresponding precedence numbers for calls.
Want to make a priority (precedence) call	Enter the MLPP access number (provided by your system administrator) followed by the phone number.
Hear a special ring (faster than usual) or special call waiting tone	You are receiving a priority (precedence) call. An MLPP icon on your phone screen indicates the priority level of the call.
Want to view priority level of a call	<p>Look for an MLPP icon on your phone screen:</p> <ul style="list-style-type: none"> ▣ Priority call ▣ Medium priority (immediate) call ▣ High priority (flash) call ▣ Highest priority (flash override) or Executive Override call <p>Higher priority calls are displayed at the top of your call list. If you do not see an MLPP icon, the priority level of the call is normal (routine).</p>
Hear a continuous tone interrupting your call	You or the other party are receiving a call that must preempt the current call. Hang up immediately to allow the higher priority call to ring through.





Tips

- When you make or receive an MLPP-enabled call, you will hear special ring tones and call waiting tones that differ from the standard tones.
- Multilevel Precedence and Preemption (MLPP) overrides the Do Not Disturb (DND) feature.

- If you enter an invalid MLPP access number, a verbal announcement will alert you of the error.
- An MLPP-enabled call retains its priority and preemptive status when you:
 - Put the call on hold
 - Transfer the call
 - Add the call to a three-way conference
 - Answer the call using PickUp

Using Cisco Extension Mobility

Cisco Extension Mobility (EM) allows you to temporarily configure a Cisco Unified IP Phone as your own. Once you log in to EM, the phone adopts your user profile, including your phone lines, features, established services, and web-based settings. Your system administrator must configure EM for you.

If you want to...	Then...
Log in to EM	<ol style="list-style-type: none"> 1. Choose  ()> Services > EM Service (name can vary). 2. Enter your user ID and PIN (provided by your system administrator). 3. If prompted, select a device profile.
Log out of EM	<ol style="list-style-type: none"> 1. Choose  ()> Services > EM Service (name can vary). 2. When prompted to log out, press Yes.

Tips

- EM automatically logs you out after a certain amount of time. Your system administrator establishes this time limit.
- Changes that you make to your EM profile (from the User Options web pages) take effect the next time that you log in to EM on a phone.
- Local settings controlled by the phone are not maintained in your EM profile.

Managing Business Calls Using a Single Phone Number











With Mobile Connect and Mobile Voice Access installed, you can use your cellular phone to handle calls associated with your desktop phone number. A *smartphone* is a mobile phone with personal computer capabilities such as web browsing, email, address book, and calendar.

If you want to...	Then...
Configure Mobile Connect	Use the User Options web pages to set up remote destinations and create access lists to allow or block calls from specific phone numbers from being passed to the remote destinations. See Setting Up Phones and Access Lists for Mobile Connect, page 60 .
Answer a call using your cellular phone	See Answering a Call, page 18 .
Switch an in-progress call between your desk phone and cellular phone	See Switching an In-Progress Call to Another Phone, page 21 .
Put a call that has been picked up on a smartphone on hold	<ol style="list-style-type: none"> 1. Press Enterprise Hold (exact softkey name can vary) on the smartphone. The other party is placed on hold. 2. Press Resume (exact softkey name can vary) on the smartphone. See Switching an In-Progress Call to Another Phone, page 21.
Transfer a call that has been picked up on a smartphone to another number	<ol style="list-style-type: none"> 1. Press Enterprise Transfer (exact softkey name can vary) on the smartphone. 2. Dial your enterprise access code for transferring calls to initiate a new call. The other party is placed on hold. 3. Press Enterprise Transfer to complete the call transfer.
Initiate a conference call on a call that has been picked up on a smartphone	<ol style="list-style-type: none"> 1. Press Enterprise Conference (exact softkey name can vary) on the smartphone. 2. Dial your enterprise access code for conferencing to initiate a new call. The other party is placed on hold. 3. Press Enterprise Conference to complete the conference set-up and include both callers in the conference.
Connect to Mobile Voice Access	<ol style="list-style-type: none"> 1. From any phone, dial your assigned Mobile Voice Access number. 2. Enter the number you are calling from, if prompted, and your PIN.

If you want to...	Then...
Turn on Mobile Connect from your cellular phone	<ol style="list-style-type: none"> 1. Dial your assigned Mobile Voice access number. 2. Enter your cellular phone number (if requested) and PIN. 3. Press 2 to enable Mobile Connect. 4. Choose whether to turn Mobile Connect on for all configured phones or just one: <ul style="list-style-type: none"> - All phones—Enter 2. - One phone—Enter 1 and enter the number you want to add as a remote destination, followed by #.
Make a call from your cellular phone	See Placing a Call—Additional Options, page 17 .
Turn off Mobile Connect from your cellular phone	<ol style="list-style-type: none"> 1. Dial your assigned Mobile Voice access number. 2. Enter your cellular phone number (if requested) and PIN. 3. Press 3 to disable Mobile Connect. 4. Choose whether to turn Mobile Connect off for all configured phones or just one: <ul style="list-style-type: none"> - All phones—Enter 2. - One phone—Enter 1 and enter the number you want to remove as a remote destination, followed by #.

Using a Handset, Headset, and Speakerphone

You can use your phone with a handset, headset, or speakerphone.







If you want to...	Then...
Use the handset	Lift it to go off-hook; replace it to go on-hook.
Use a headset	<p>Press  () to toggle headset mode on and off. (Typically, headset is assigned to button 23.) You can use a headset with all of the controls on your phone, including the Volume button and .</p> <p>If you use AutoAnswer, see Using AutoAnswer, page 42.</p> <p>If you use a headset that supports wideband, you might experience improved audio sensitivity if you enable the wideband setting on your phone (this setting is disabled by default). To access the setting, choose  () > Settings > User Preferences > Audio Preferences > Wideband Headset. If the Wideband Handset setting shows as dimmed, then this setting is not user controllable.</p> <p>Check with your system administrator to be sure your phone system is configured to use wideband. If the system is not configured for wideband, you may not detect any additional audio sensitivity even when using a wideband headset. To learn more about your headset, refer to the headset documentation or ask your system administrator for assistance.</p>
Use the speakerphone	<p>Press  to toggle speakerphone mode on or off.</p> <p>Many of the actions you can take to dial a number or answer a call will automatically trigger speakerphone mode, assuming that the handset is in its cradle and  (headset) is not lit.</p>
Switch to the speakerphone or a headset (from the handset) during a call	Press  or  (), then hang up the handset.
Switch to the handset (from the speakerphone or headset) during a call	Lift the handset (without pushing any buttons).
Adjust the volume level for a call	<p>Press the Volume button during a call or after invoking a dial tone. This action adjusts the volume for the handset, speakerphone, or headset, depending on which device is in use.</p> <p>Press Save to preserve the volume level for future calls.</p>

Obtaining a Headset

Your phone supports four- or six-wire headset jacks. For information about purchasing headsets, see [Headset Information, page 5](#).

Using AutoAnswer

When AutoAnswer is enabled, your phone answers incoming calls automatically after a few rings. Your system administrator configures AutoAnswer to use either the speakerphone or a headset. You might use AutoAnswer if you receive a high volume of incoming calls.

If you...	Then...
Use AutoAnswer with a headset	<p>Keep headset mode active (in other words, keep  () illuminated), even when you are not on a call.</p> <p>To keep headset mode active, do the following:</p> <ul style="list-style-type: none">• Press EndCall to hang up.• Press New Call or Dial to place new calls. <p>If your phone is set up to use AutoAnswer in headset mode, calls are automatically answered only if  () is illuminated. Otherwise, calls ring normally and you must manually answer them.</p>
Use AutoAnswer with the speakerphone	<p>Keep the handset in the cradle and headset mode inactive ( () unlit).</p> <p>Otherwise, calls ring normally and you must manually answer them.</p>

Tip



AutoAnswer is disabled when the Do Not Disturb feature is active.

Changing Phone Settings

You can personalize your Cisco Unified IP Phone by adjusting the ring tone, volume, and other settings.



Customizing Rings and Message Indicators

You can customize how your phone indicates an incoming call and a new voice mail message. You can also adjust the ringer volume for your phone.



If you want to...	Then...
Change the ring tone per line	<ol style="list-style-type: none"> 1. Choose  () > Settings > User Preferences > Rings. 2. Choose a phone line or the default ring setting. 3. Choose a ring tone to play a sample of it. 4. Press Select and Save to set the ring tone, or press Cancel.
Adjust the volume level for the phone ringer	Press the Volume button while the handset is in the cradle and the headset and speakerphone buttons are off. The new ringer volume is saved automatically.
Change the way that the voice message light on your handset works	<ol style="list-style-type: none"> 1. Log in to your User Options web pages. (See Accessing Your User Options Web Pages, page 52.) 2. Access your message indicator settings. (See Controlling Line Settings on the Web, page 58.) <p>Note Typically, the default system policy is to indicate a new voice message by displaying a steady light on the handset light strip.</p>
Change the way the audible voice message indicator sounds on your phone	<ol style="list-style-type: none"> 1. Log in to your User Options web pages. (See Accessing Your User Options Web Pages, page 52.) 2. Access your message indicator settings. (See Controlling Line Settings on the Web, page 58.)

Customizing the Phone Screen

You can adjust the characteristics of the phone screen.













If you want to...	Then...
Change the phone screen brightness	<ol style="list-style-type: none"><li data-bbox="370 302 1104 329">1. Choose  > Settings > User Preferences > Brightness.<li data-bbox="370 337 956 365">2. To make adjustments, press the Volume button.<li data-bbox="370 373 728 401">3. Press Save, or press Cancel.
Change the language on your phone screen	<ol style="list-style-type: none"><li data-bbox="370 459 1166 513">1. Log in to your User Options web pages. (See Accessing Your User Options Web Pages, page 52.)<li data-bbox="370 521 1201 574">2. Access your user settings. (See Controlling User Settings on the Web, page 57.)
Change the line text label	<ol style="list-style-type: none"><li data-bbox="370 605 1166 659">1. Log in to your User Options web pages. (See Accessing Your User Options Web Pages, page 52.)<li data-bbox="370 667 1188 721">2. Access your line label settings. (See Controlling Line Settings on the Web, page 58.)
Adjust contrast	<ol style="list-style-type: none"><li data-bbox="370 751 1085 779">1. Choose  > Settings > User Preferences > Contrast.<li data-bbox="370 787 956 815">2. To make adjustments, press the Volume button.<li data-bbox="370 823 728 850">3. Press Save, or press Cancel.
Turn off the backlight	Contact your system administrator to see if this optional feature is available to you. This feature allows you to turn off the backlight for a pre-determined time (as set by your system administrator).







Using Call Logs and Directories

This section describes how you can use call logs and directories. To access both features, use the Directories button  () > Directories.

Using Call Logs

Your phone maintains call logs. Call logs contain records of your missed, placed, and received calls.

If you want to...	Then...
View your call logs	Choose  () > Directories > Missed Calls, Placed Calls, or Received Calls . Each stores up to 100 records.
Display details for a single call record	<ol style="list-style-type: none"> 1. Choose  () > Directories > Missed Calls, Placed Calls, or Received Calls. 2. Highlight a call record. 3. Press Details. Doing so displays information such as called number, calling number, time of day, and call duration (for placed and received calls only).
Erase all call records in all logs	Choose  () > Directories, then press Clear .
Erase all call records in a single log	<ol style="list-style-type: none"> 1. Choose  () > Directories > Missed Calls, Placed Calls, or Received Calls. 2. Highlight a call record. 3. Press Clear. (You may need to press the more softkey to display Clear.)
Erase a single call record	<ol style="list-style-type: none"> 1. Choose  () > Directories > Missed Calls, Placed Calls, or Received Calls. 2. Highlight a call record. 3. Press Delete.
View intercom call history	Choose  () > Directories > Intercom History . Details of the 25 most recent intercom calls are logged. You cannot dial intercom numbers from this screen.

If you want to...	Then...
Dial from a call log (while not on another call)	<ol style="list-style-type: none"> 1. Choose  () > Directories > Missed Calls, Placed Calls, or Received Calls. 2. Highlight a call record. <p>Note If the Details softkey appears, the call is the primary entry of a multiparty call. See the Tips section below.</p> <ol style="list-style-type: none"> 3. If you need to edit the displayed number, press EditDial followed by << or >>. To delete the number, press EditDial followed by Delete. (You may need to press the more softkey to display Delete.) 4. Go off-hook to place the call.
Dial from a call log (while connected to another call)	<ol style="list-style-type: none"> 1. Choose  () > Directories > Missed Calls, Placed Calls, or Received Calls. 2. Highlight a call record. <p>Note If the Details softkey appears, the call is the primary entry of a multiparty call. See the Tips section below.</p> <ol style="list-style-type: none"> 3. If you need to edit the displayed number, press EditDial followed by << or >>. To delete the number, press EditDial followed by Delete. (You may need to press the more softkey to display Delete.) 4. Press Dial. 5. Choose a menu item to handle the original call: <ul style="list-style-type: none"> – Hold—Puts the first call on hold and dials the second. – Transfer—Transfers the first party to the second and drops you from the call. (Press  again after dialing to complete the action.) – Conference—Creates a conference call with all parties, including you. (Press  () again after dialing to complete the action.) – EndCall—Disconnects the first call and dials the second.

Tips

To view the complete call record of a multiparty call (for example, of call that has been forwarded or transferred to you), highlight the call record and press **Details**. The Details record shows two entries for each missed or received multiparty call. The entries are listed in reverse chronological order:

- The first logged entry is the name/number of the last completed call of a multiparty call received on your phone.
- The second logged entry is the name/number of the first completed call of a multiparty call received on your phone.







Directory Dialing

Depending on configuration, your phone can provide corporate and personal directory features:

- **Corporate Directory**—Corporate contacts that you can access on your phone. Your system administrator sets up and maintains your Corporate Directory.
- **Personal Directory**—If available, personal contacts and associated speed-dial codes that you can configure and access from your phone and User Options web pages. Personal Directory is comprised of Personal Address Book (PAB) and Fast Dials:
 - PAB is a directory of your personal contacts.
 - Fast Dials allows you to assign codes to PAB entries for quick dialing.

Using Corporate Directory on Your Phone

You can use a corporate directory to place calls to coworkers.



If you want to...	Then...
Dial from a corporate directory (while not on another call)	<ol style="list-style-type: none"> 1. Choose  () > Directories > Corporate Directory (exact name can vary). 2. Use your keypad to enter a full or partial name and press Search. 3. To dial, press the listing, or scroll to the listing and go off-hook.
Dial from a corporate directory (while on another call)	<ol style="list-style-type: none"> 1. Choose  () > Directories > Corporate Directory (exact name can vary). 2. Use your keypad to enter a full or partial name and press Search. 3. Scroll to a listing and press Dial. 4. Choose a menu item to handle the original call: <ul style="list-style-type: none"> – Hold—Puts the first call on hold and dials the second. – Transfer—Transfers the first party to the second and drops you from the call. (Press  again after dialing to complete the action.) – Conference—Creates a conference call with all parties, including you. (Press  () again after dialing to complete the action.) – EndCall—Disconnects the first call and dials the second.





Tip



Use the numbers on your keypad to enter characters on your phone screen. Use the Navigation button on your phone to move between input fields.

Using Personal Directory on Your Phone

The Personal Directory feature set contains your Personal Address Book (PAB) and Fast Dials. This section describes how to set up and use Personal Directory on your phone. Alternately, see [Using Personal Directory on the Web, page 53](#).

If you want to...	Then...
Access Personal Directory (for PAB and Fast Dial codes)	<ol style="list-style-type: none"> 1. Choose  () > Directories > Personal Directory (exact name can vary). 2. Enter your Cisco Unified Communications Manager user ID and PIN, then press Submit.
Search for a PAB entry	<ol style="list-style-type: none"> 1. Access Personal Directory, then choose Personal Address Book. 2. Enter search criteria and press Submit. 3. You can choose Previous or Next to move through listings. 4. Highlight the PAB listing that you want and press Select.
Dial from PAB entry	<ol style="list-style-type: none"> 1. Search for a listing. 2. Highlight the listing and press Select. 3. Press Dial. (You may need to press the more softkey to see Dial.) 4. Enter the participant's phone number. 5. Highlight the number that you want to dial and press OK. 6. Press OK again to dial the number.
Delete a PAB entry	<ol style="list-style-type: none"> 1. Search for a listing. 2. Highlight the listing and press Select. 3. Press Delete. 4. Choose OK to confirm the deletion.
Edit a PAB entry	<ol style="list-style-type: none"> 1. Search for a listing. 2. Highlight the listing and press Edit to modify a name or email address. 3. If necessary, choose Phones to modify a phone number. 4. Press Update.

If you want to...	Then...
Add a new PAB entry	<ol style="list-style-type: none"> 1. Access Personal Directory, then choose Personal Address Book. 2. Access the Search page by choosing Submit. (You do not need to input search information first.) 3. Press New. 4. Use your phone keypad to enter a name and email information. 5. Choose Phones and use the keypad to enter phone numbers. Be sure to include any necessary access codes such as a 9 or 1. 6. Choose Submit to add the entry to the database.
Assign a Fast Dial code to a PAB entry	<ol style="list-style-type: none"> 1. Search for a PAB entry. 2. Highlight the listing and press Select. 3. Press Fast Dial. 4. Highlight the number that you want to dial and press Select. 5. Highlight the Fast Dial code that you want to assign to the number and press Select.
Add a new Fast Dial code (not using a PAB entry)	<ol style="list-style-type: none"> 1. Choose  () > Directories > Personal Directory > Personal Fast Dials. 2. Press Fast Dial. 3. Highlight a Fast Dial code that is unassigned and press Select. 4. Press Assign. 5. Enter a phone number. 6. Press Update.
Search for Fast Dial codes	<ol style="list-style-type: none"> 1. Choose  () > Directories > Personal Directory > Personal Fast Dials. 2. You can choose Previous or Next to move through listings. 3. Highlight the listing that you want and press Select.
Place a call using a Fast Dial code	<ol style="list-style-type: none"> 1. Search for a Fast Dial code. 2. Highlight the listing you want and press Select. 3. Press Dial. 4. Choose OK to complete the action.

If you want to...	Then...
Delete a Fast Dial code	<ol style="list-style-type: none"> 1. Search for a Fast Dial code. 2. Highlight the listing you want and press Select. 3. Press Remove.
Log out of Personal Directory	<ol style="list-style-type: none"> 1. Choose  () > Directories > Personal Directory (exact name can vary). 2. Choose Logout.

Tips



- Your system administrator can provide you the user ID and PIN that you need to log in to Personal Directory.
- Personal Directory automatically logs you out after a certain amount of time. This time limit can vary. Ask your system administrator for more information.
- Use the numbers on your keypad to enter characters on your phone screen. Use the Navigation button on your phone to move between input fields.

Accessing Voice Messages

To access voice messages, use the Messages button  > **Messages**.



Note Your company determines the voice message service that your phone system uses. For the most accurate and detailed information, refer to the documentation that came with your voice message service.

If you want to...	Then...
Set up and personalize your voice message service	Press  > Messages and follow the voice instructions. If a menu appears on your phone screen, choose an appropriate menu item.
Check for your new voice messages	Look for: <ul style="list-style-type: none"> • A steady red light on your handset. (This indicator can vary. See Customizing Rings and Message Indicators, page 43.) • A message waiting icon  and text message on your phone screen. <p>Note The red light and message waiting icon display only when you have a message on your primary line, even if you receive voice messages on other lines.</p> Listen for: <ul style="list-style-type: none"> • A stutter tone from your handset, headset, or speakerphone when you place a call. <p>Note The stutter tone is line-specific. You hear it only when using the line with the waiting message.</p>
Listen to your voice messages or access the voice messages menu	Press  > Messages . Depending on your voice message service, doing so either auto-dials the message service or provides a menu on your phone screen.
Send a call to a voice message system	Press iDivert . For more information, see Sending a Call to a Voice Message System, page 23.

Using the User Options Web Pages

Your Cisco Unified IP Phone is a network device that can share information with other network devices in your company, including your personal computer. You can use your computer to log in to your Cisco Unified CM User Options web pages, where you can control features, settings, and services for your Cisco Unified IP Phone. For example, you can set up speed-dial buttons from your User Options web pages.

Accessing Your User Options Web Pages

This section describes how to log in and select a phone device.

If you want to...	Then do this...
Log in to your User Options web pages	<ol style="list-style-type: none"><li data-bbox="322 675 1171 734">1. Obtain a User Options URL, user ID, and default password from your system administrator.<li data-bbox="322 740 1134 773">2. Open a web browser on your computer, enter the URL, and log on.<li data-bbox="322 779 1163 812">3. If prompted to accept security settings, click Yes or Install Certificate. <p data-bbox="365 824 1206 915">The Cisco Unified Communications Manager User Options main web page displays. From this page you can choose User Options to access User Settings, Directory features, a Personal Address Book, and Fast Dials.</p> <p data-bbox="365 928 1094 961">Or, to access phone-specific options, select a device (see below).</p>
Select a device after logging in	<ol style="list-style-type: none"><li data-bbox="322 977 1177 1036">1. After you have logged in to your User Options web pages, choose User Options > Device. <p data-bbox="365 1042 830 1075">The Device Configuration page displays.</p> <ol style="list-style-type: none"><li data-bbox="322 1081 1206 1172">2. If you have multiple devices assigned to you, choose the appropriate device (phone model, Extension Mobility profile, or Remote Destination profile) from the Name drop-down menu. <p data-bbox="317 1185 1185 1243">Note Toolbar buttons located at the top of the Device Configuration page are specific to the selected device type.</p>
Select a configuration option after logging in	<ol style="list-style-type: none"><li data-bbox="322 1260 1185 1351">1. After you have logged in to your User Options web pages, choose User Options to access User Settings, Directory, Personal Address Book, Fast Dials, and Mobility Settings.<li data-bbox="322 1357 1174 1416">2. To return to the Device Configuration page from another page, choose User Options > Device.

Configuring Features and Services on the Web

The topics in this section describe how to configure features and services from your User Options web pages after logging in. See [Accessing Your User Options Web Pages, page 52](#).

Using Personal Directory on the Web

The Personal Directory feature set that you can access on your computer consists of:

- A Personal Address Book (PAB)
- Fast Dials
- Cisco Unified Communications Manager Address Book Synchronizer



Note You can also access PAB and Fast Dials from your phone. See [Using Personal Directory on Your Phone, page 48](#).

Using Your Personal Address Book on the Web

This section describes how to use your PAB from your User Options web pages.

If you want to...	Then do this after you log in...
Add a new PAB entry	<ol style="list-style-type: none"> 1. Choose User Options > Personal Address Book. 2. Click Add New. 3. Enter information for the entry. 4. Click Save.
Search for a PAB entry	<ol style="list-style-type: none"> 1. Choose User Options > Personal Address Book. 2. Specify search information and click Find.
Edit a PAB entry	<ol style="list-style-type: none"> 1. Search for a PAB entry. 2. Click a name or nickname. 3. Edit the entry as needed and click Save.
Delete a PAB entry	<ol style="list-style-type: none"> 1. Search for a PAB entry. 2. Select one or more entries. 3. Click Delete Selected.

Configuring Fast Dials on the Web

This section describes how to assign Fast Dials from your User Options web pages.

If you want to...	Then do this after you log in...
Assign a Fast Dial code to a PAB entry	<ol style="list-style-type: none">1. Create a PAB entry. See Using Your Personal Address Book on the Web, page 53.2. Choose User Options > Fast Dials.3. Click Add New.4. Use the Search Options area to find the appropriate PAB entry.5. Click a phone number in the Search Results area.6. Change the Fast Dial code, if desired.7. Click Save.
Assign a Fast Dial code to a phone number (without using a PAB entry)	<ol style="list-style-type: none">1. Choose User Options > Fast Dials.2. Click Add New.3. Change the Fast Dial code, if desired.4. Enter a phone number.5. Click Save.
Search for a Fast Dial entry	<ol style="list-style-type: none">1. Choose User Options > Fast Dials.2. Specify search information and click Find.
Edit a Fast Dial phone number	<ol style="list-style-type: none">1. Choose User Options > Fast Dials.2. Search for the Fast Dial entry that you want to edit.3. Click on a component of the entry.4. Change the phone number.5. Click Save.
Delete a Fast Dial entry	<ol style="list-style-type: none">1. Search for a Fast Dial.2. Select one or more entries.3. Click Delete Selected.

Tips

- You can create up to 500 Fast Dial and PAB entries.
- You can create a new Fast Dial entry without using a PAB entry. Such Fast Dial entries are labeled “raw” in the User Options web pages and do not display a configurable text label.

Using the Address Book Synchronization Tool

You can use the Address Book Synchronization Tool (TABSynch) to synchronize your existing Microsoft Windows Address Book (if applicable) with your PAB. Entries from your Microsoft Windows Address Book will then be accessible on your Cisco Unified IP Phone and User Options web pages. Your system administrator can give you access to TABSynch and provide detailed instructions.

Setting Up Speed Dials on the Web

Depending on configuration, your phone can support several speed-dial features:

- Speed-dial buttons
- Abbreviated Dialing
- Fast Dials



Note For help using speed-dial features, see [Speed Dialing, page 30](#).

If you want to...	Then do this after you log in...
Set up speed-dial buttons	<ol style="list-style-type: none"> 1. Choose User Options > Device. 2. Choose a phone from the Name drop-down menu. 3. Click Speed Dials. 4. Enter a number and label for a speed-dial button (programmable button) on your phone. 5. Click Save. <p>Note Your phone uses the ASCII Label field.</p>
Set up Abbreviated Dialing	<ol style="list-style-type: none"> 1. Choose User Options > Device. 2. Choose a phone from the Name drop-down menu. 3. Click Speed Dials. 4. Enter a number and label for an Abbreviated Dialing code. 5. Click Save.
Set up Fast Dials	<p>See Configuring Fast Dials on the Web, page 54.</p> <p>You can also set up Fast Dials on your phone. See Using Personal Directory on Your Phone, page 48.</p>



Tip

You can set up a speed-dial button for each programmable button on your phone that is not reserved as line button. Alternately, use Abbreviated Dial or Fast Dial.

Setting Up Phone Services on the Web

Phone services can include special phone features, network data, and web-based information (such as stock quotes and movie listings). You must first subscribe to a phone service before accessing it on your phone.

If you want to...	Then do this after you log in...
Subscribe to a service	<ol style="list-style-type: none">1. Choose User Options > Device.2. Choose a phone from the Name drop-down menu.3. Click Phone Services.4. Click Add New.5. Choose a service from the drop-down list and click Next.6. Change the service label and/or enter additional service information, if available (optional).7. Click Save.
Search for services	<ol style="list-style-type: none">1. Select a device.2. Click Phone Services.3. Click Find.
Change or end services	<ol style="list-style-type: none">1. Search for services.2. Select one or more entries.3. Click Delete Selected.
Change a service name	<ol style="list-style-type: none">1. Search for services.2. Click on the service name.3. Change the information and click Save.

If you want to...	Then do this after you log in...
Add a service to an available programmable phone button 	<ol style="list-style-type: none"> 1. Choose User Options > Device. 2. Choose a phone from the Name drop-down menu. 3. Click Service URL. <p>Note If you do not see this option, ask your system administrator to configure a service URL button for your phone.</p> <ol style="list-style-type: none"> 4. Choose a service from the Button Service drop-down list. 5. If you want to rename the service, edit the label fields. <p>Note Your phone uses the ASCII Label field if the phone does not support double-byte character sets.</p> <ol style="list-style-type: none"> 6. Click Save. 7. Click Reset to reset your phone (necessary to see the new button label on your phone).
Access a service on your phone	Choose  () > Services .

Controlling User Settings on the Web

User settings include your password, PIN, and language (locale) settings.

If you want to...	Then do this after you log in...
Change your password	<ol style="list-style-type: none"> 1. Choose User Options > User Settings. 2. In the Browser Password area, enter information. 3. Click Save.
Change your PIN	<ol style="list-style-type: none"> 1. Choose User Options > User Settings. 2. In the Phone PIN area, enter information. 3. Click Save.
Change the language (locale) for your User Options web pages	<ol style="list-style-type: none"> 1. Choose User Options > User Settings. 2. In the User Locale area, choose an item from the Locale drop-down list. 3. Click Save.
Change the language (locale) for your phone screen	<ol style="list-style-type: none"> 1. Choose User Options > User Settings. 2. Choose an item from the User Locale drop-down list. 3. Click Save.

Tip

Your PIN and password allow you to access different features and services. For example, use your PIN to log in to Cisco Extension Mobility or Personal Directory on your phone. Use your password to log in to your User Options web pages and Cisco WebDialer on your personal computer. For more information, ask your system administrator.

Controlling Line Settings on the Web

Line settings affect a specific phone line (directory number) on your phone. Line settings can include call-forwarding, voice message indicators, ring patterns, and line labels.

You can set up other line settings directly on your phone:

- Set up call forwarding for your primary phone line—see [Forwarding All Calls to Another Number, page 24](#).
- Change rings, display, and other phone-model specific settings—see [Changing Phone Settings, page 43](#).

If you want to...	Then do this after you log in...
Set up call forwarding per line	<ol style="list-style-type: none">1. Choose User Options > Device.2. Choose a phone from the Name drop-down menu.3. Click Line Settings.4. If you have more than one directory number (line) assigned to your phone, choose a line from the Line drop-down menu.5. In the Incoming Call Forwarding area, choose call forwarding settings for various conditions.6. Click Save.
Change the voice message indicator (lamp) setting per line	<ol style="list-style-type: none">1. Choose User Options > Device.2. Choose a phone from the Name drop-down menu.3. Click Line Settings.4. If you have more than one directory number (line) assigned to your phone, choose a line from the Line drop-down menu.5. In the Message Waiting Lamp area, choose from various settings. <p>Note Typically, the default message waiting setting prompts your phone to display a steady red light from the handset light strip to indicate a new voice message.</p> <ol style="list-style-type: none">6. Click Save.

If you want to...	Then do this after you log in...
Change the audible voice message indicator setting per line	<ol style="list-style-type: none"> 1. Choose User Options > Device. 2. Choose a phone from the Name drop-down menu. 3. Click Line Settings. 4. If you have more than one directory number (line) assigned to your phone, choose a line from the Line drop-down menu. 5. In the Audible Message Waiting Indicator area, choose from various settings. <p>Note Typically, the default message waiting setting prompts your phone to display a steady red light from the handset light strip to indicate a new voice message.</p> <ol style="list-style-type: none"> 6. Click Save.
Change or create a line text label that appears on your phone screen	<ol style="list-style-type: none"> 1. Choose User Options > Device. 2. Choose a phone from the Name drop-down menu. 3. Click Line Settings. 4. If you have more than one directory number (line) assigned to your phone, choose a line from the Line drop-down menu. 5. In the Line Text Label area, enter a text label. 6. Click Save. <p>Note Your phone uses the ASCII Label field if the phone does not support double-byte character sets.</p>

Setting Up Phones and Access Lists for Mobile Connect

When using Cisco Mobile Connect, you must add your cellular and other phones that you want to use to make and receive calls using the same directory numbers as your desk phone. These phones are called *remote destinations*. You can also define access lists to restrict or allow calls from certain numbers to be sent to your cellular phone.

If you want to...	Then do this after you log in...
Create an access list	<ol style="list-style-type: none">1. Choose User Options > Mobility Settings > Access Lists.2. Click Add New.3. Enter the following information:<ul style="list-style-type: none">- Name—Identifies the access list.- Description—Describes the access list.4. Choose one of these options:<ul style="list-style-type: none">- Blocked Access List—Creates list for numbers to be blocked- Allowed Access List—Creates list for numbers that will be permitted5. Click Save.

If you want to...	Then do this after you log in...
Add members to an access list.	<ol style="list-style-type: none">1. Create an access list.2. Click Add Member to add phone numbers or filters to the list.3. Select an option from the Filter Mask drop-down list box. You can filter a directory number, calls with restricted caller ID (Not Available), or calls with anonymous caller ID (Private).4. If you select a directory number from the Filter Mask drop-down list box, enter a phone number or filter in the DN Mask field. You can use the following wild cards to define a filter:<ul style="list-style-type: none">- X (upper or lower case)—Matches a single digit. For example, 408555123X matches any number between 4085551230 and 4085551239.- !—Matches any number of digits. For example, 408! matches any number starts with 408.- #—Used as a single digit for exact match.5. To add this member to the access list, click Save.6. To save the access list, click Save.

If you want to...	Then do this after you log in...
Add a new remote destination	<ol style="list-style-type: none"> 1. Choose User Options > Mobility Settings > Remote Destinations. 2. Select the device from the Name drop-down list box. 3. Click Remote Destinations. 4. Click Add New. 5. Enter the following information: <ul style="list-style-type: none"> - Name—Enter a name for the cellular (or other) phone. - Destination Number—Enter your cellular phone number. - Answer Too Soon Timer—Enter the amount of time before you can pick up a call on the remote destination (in milliseconds). - Answer Too Late Timer—Enter the amount of time after which it is too late to pick up a call on the remote destination (in milliseconds). - Delay Before Ringing Timer—Enter the amount of time before the call rings on the remote destination (in milliseconds). - Remote Destination Profile—Select a remote destination profile, which contains the settings that apply to all of your remote destinations. - Allowed Access List—Select a phone number or rule that allows your cellular phone to ring when a call comes in to your desktop phone. You can select an allowed access list or blocked access list, but not both. - Blocked Access List—Select a phone number or rule for which your cellular phone does not ring when a call comes in to your desktop phone. You can select an allowed access list or blocked access list, but not both. - Mobile Phone—Select to allow your cellular phone can accept a call sent from your desktop phone. - Enable Mobile Connect—Select to allow your cellular phone to ring simultaneously with your desktop phone. - Smart Client Installed—Select to indicate that the remote destination you are setting up is a smartphone. 6. Click Save.

Understanding Additional Configuration Options

Your system administrator can configure your phone to use specific button and softkey templates along with special services and features, if appropriate. This table provides an overview of some configuration options that you might want to discuss with your phone system administrator based on your calling needs or work environment.

Note

You can locate Phone Guides and other documents listed in this table on the web:
http://www.cisco.com/en/US/products/hw/phones/ps379/tsd_products_support_series_home.html

If you...	Then...	For more information...
Need more than one phone line	Ask your system administrator to configure one or more additional directory numbers for you.	Talk to your system administrator or phone support team.
Need more speed-dial buttons	First make sure that you are using all of your currently available speed-dial buttons. If you need additional speed-dial buttons, try using Abbreviated Dialing or subscribing to the Fast Dial service.	See Speed Dialing , page 30.
Want to use one extension for several phones	Request a shared line. This allows you to use one extension for your desk phone and lab phone, for example.	See Using a Shared Line , page 34.
Share phones or office space with coworkers	Consider using: <ul style="list-style-type: none"> • Call Park to store and retrieve calls without using the transfer feature. • Call Pickup to answer calls ringing on another phone. • A shared line to view coworkers' calls. • Cisco Extension Mobility to apply your phone number and user profile to a shared Cisco Unified IP Phone. 	Ask your system administrator about these features and see: <ul style="list-style-type: none"> • Advanced Call Handling, page 30. • Using a Shared Line, page 34. • Using Cisco Extension Mobility, page 38.

If you...	Then...	For more information...
Answer calls frequently or handle calls on someone's behalf	Ask your system administrator to set up the AutoAnswer feature for your phone.	See Using AutoAnswer, page 42 .
Need to make video calls	Consider using Cisco Unified Video Advantage, which enables you to make video calls using your Cisco Unified IP Phone, your personal computer, and an external video camera.	Contact your system administrator for additional assistance and see the <i>Cisco Unified VT Advantage Quick Start Guide</i> and <i>User Guide</i> .
Determine the state of a phone line associated with a speed-dial button on your phone	Ask your administrator to set up the Busy Lamp Field (BLF) feature for your phone.	See Using BLF to Determine a Line State, page 35 .
Want to temporarily apply your phone number and settings to a shared Cisco Unified IP Phone	Ask your system administrator about the Cisco Extension Mobility Service.	See Using Cisco Extension Mobility, page 38 .

Troubleshooting Your Phone

This section provides troubleshooting information for your Cisco Unified IP Phone.









General Troubleshooting

This section provides information to help you troubleshoot general problems with your phone. For more information, see your system administrator.

Symptom	Explanation
You cannot hear a dial tone or complete a call	One or more of the following factors might apply: <ul style="list-style-type: none"> You must log into the Extension Mobility service. You must enter a client matter code (CMC) or forced authorization code (FAC) after dialing a number. Your phone has time-of-day restrictions that prevent you from using some features during certain hours of the day.
Settings is unavailable in the Application menu.	Your system administrator might have disabled Settings on your phone.
The softkey that you want to use does not appear	One or more of the following factors might apply: <ul style="list-style-type: none"> You must press more to reveal additional softkeys. You must change the line state (for example, go off-hook or have a connected call). Your phone is not configured to support the feature associated with that softkey.
Cisco CallBack fails	The other party might have call forwarding enabled.

Viewing Phone Administration Data

Your system administrator might ask you to access administration data on your phone for troubleshooting purposes.

If you are asked to...	Then...
Access network configuration data	Choose  () > Settings > Network Configuration and select the network configuration item that you want to view.
Access status data	Choose  () > Settings > Status and select the status item that you want to view.
Access phone model information	Choose  () > Settings > Model Information .
Access phone call and voice quality information	Choose  () > Settings > Status > Call Statistics .

Cisco One-Year Limited Hardware Warranty Terms

There are special terms applicable to your hardware warranty and various services that you can use during the warranty period. Your formal Warranty Statement, including the warranties and license agreements applicable to Cisco software, is available on Cisco.com. Follow these steps to access and download the *Cisco Information Packet* and your warranty and license agreements from Cisco.com.

1. Launch your browser, and go to this URL:

http://www.cisco.com/univercd/cc/td/doc/es_inpk/cetrans.htm

The Warranties and License Agreements page appears.

2. To read the *Cisco Information Packet*, follow these steps:

- a. Click the **Information Packet Number** field, and make sure that the part number 78-5235-03B0 is highlighted.
- b. Select the language in which you would like to read the document.
- c. Click **Go**.

The Cisco Limited Warranty and Software License page from the Information Packet appears.

- d. Read the document online, or click the **PDF** icon to download and print the document in Adobe Portable Document Format (PDF).

Note You must have Adobe Acrobat Reader to view and print PDF files. You can download the reader from Adobe's website: <http://www.adobe.com>

3. To read translated and localized warranty information about your product, follow these steps:

- a. Enter this part number in the Warranty Document Number field:
78-10747-01C0
- b. Select the language in which you would like to view the document.
- c. Click **Go**.

The Cisco warranty page appears.

- d. Read the document online, or click the **PDF** icon to download and print the document in Adobe Portable Document Format (PDF).

You can also contact the Cisco service and support website for assistance:

http://www.cisco.com/public/Support_root.shtml.

Duration of Hardware Warranty

One (1) Year

Replacement, Repair, or Refund Policy for Hardware

Cisco or its service center will use commercially reasonable efforts to ship a replacement part within ten (10) working days after receipt of a Return Materials Authorization (RMA) request. Actual delivery times can vary, depending on the customer location.

Cisco reserves the right to refund the purchase price as its exclusive warranty remedy.

To Receive a Return Materials Authorization (RMA) Number

Contact the company from whom you purchased the product. If you purchased the product directly from Cisco, contact your Cisco Sales and Service Representative.

Complete the information below, and keep it for reference.

Company product purchased from	
Company telephone number	
Product model number	
Product serial number	
Maintenance contract number	

Index

A

Abbreviated Dialing [30, 55](#)
Address Book Synchronization Tool [55](#)
answering calls [18](#)
ASCII label field support [55](#)
audio, quality of [6](#)
authenticated calls [36](#)
Auto Dial [16](#)
AutoAnswer [42](#)

B

barge
 and shared lines [34](#)
BLF [35](#)
Busy Lamp Field [35](#)
button [29](#)

C

call forwarding
 configuring from web page [58](#)
 configuring on phone [24](#)
call logs
 erasing [45](#)
 viewing and dialing from [45](#)
call park [32](#)

call pickup [31](#)
call waiting [18](#)
CallBack [17](#)
calls
 answering [18](#)
 barging [34](#)
 blocking [25](#)
 compared to lines [10](#)
 conference features for [26](#)
 ending [19](#)
 forwarding [24, 58](#)
 handling multiple [21](#)
 icons for [11](#)
 maximum per line [10](#)
 multiple parties on [26](#)
 multiple, switching between [21](#)
 muting [21](#)
 parking [32](#)
 placing [16, 17](#)
 prioritizing [37](#)
 redirecting while ringing [31](#)
 secure [36](#)
 storing and retrieving [32](#)
 transferring [22](#)
 using DND [25](#)
Cisco Extension Mobility [38](#)
Cisco Unified Communications Manager
 Address Book Synchronizer [55](#)

- Cisco Unified IP Phone
 - troubleshooting [65](#)
 - web-based services for [52](#)
- Cisco Unified Video Advantage [64](#)
- Client Matter Code, see CMC
- CMC [17, 65](#)
- conference
 - secure [27](#)
- conference calls
 - Meet-Me [26, 28](#)
 - standard [26](#)
- connected [11](#)
- corporate directory
 - using on phone [45, 47](#)

D

- Details softkey, viewing multiparty calls with [46](#)
- device configuration page [52](#)
- dialing, options for [16, 17](#)
- directory
 - corporate [47](#)
 - personal [47, 48](#)
 - using on phone [47](#)
- DND [25](#)
- Do Not Disturb [25](#)

E

- EM [38](#)
- encrypted calls [36](#)
- ending a call, options for [19](#)
- Extension Mobility [38](#)

F

- FAC [17, 65](#)
- Fast Dials
 - configuring from web page [54](#)
 - using on phone [48](#)
- Forced Authorization Code, see FAC
- forwarding calls, options for [24](#)

G

- group call pickup [31](#)

H

- handset
 - using [41](#)
- hanging up, options for [19](#)
- headset
 - answering calls with [18](#)
 - hanging up with [19](#)
 - placing calls with [16](#)
 - using [41](#)
- headset performance, general [5](#)
- hold
 - and switching calls [21](#)
 - and transferring [22](#)
- Hunt groups, logging out [33](#)

I

- icons
 - for call states [11](#)
 - for lines [11](#)

idle **11**
intercom line **11, 29**

L

language (locale) settings **57**
lines
 and call forwarding **24, 58**
 and call states **11**
 and using BLF **35**
 description of **10**
 icons for **11**
 number of calls supported on **10**
 ring patterns for **58**
 ring tones for **43**
 shared **34**
 switching between **21**
 text label for **58**
 voice message indicator setting for **58**
logging out of hunt groups **33**

M

Malicious Call Identification **36**
MCID **36**
Meet-Me conferences **26, 28**
messages
 indicator for **43, 51**
 listening to **51**
missed calls, records of **45**
MLPP, using **37**
multiparty calls
 identifying in call logs **46**

 viewing details of **46**
multiple calls, handling **21**
mute, using **21**

N

network configuration data, locating **65**

O

on-hook dialing **16**

P

PAB
 using from web page **53**
 using on phone **48**
password, changing **57**
Personal Address Book, see PAB
Personal Directory
 using from web page **53**
 using on phone **48**
phone lines
 description of **10**
phone screen
 adjusting contrast **44**
 changing language **44**
 illumination setting **44**
phone services
 configuring
 see also User Options web pages
PIN, changing **57**
placed calls, records of **45**

- placing calls, options for [16, 17](#)
- pre-dial [16](#)
- prioritizing calls [37](#)
- privacy
 - and shared lines [34](#)

R

- received calls, records of [45](#)
- redial [16](#)
- remote-in-use icon for shared lines [34](#)
- ring patterns, changing [58](#)
- ring tones, changing [43](#)
- ringer
 - customizing [43](#)
 - volume for [43](#)

S

- secure calls [36](#)
- secure conference
 - verifying [27](#)
- secure conference, starting [27](#)
- security, for calls [36](#)
- services, subscribing to [56](#)
- shared lines
 - and remote-in-use icon [34](#)
 - description of [34](#)
- softkey buttons
 - description of [9](#)
- speakerphone
 - answering calls with [18](#)
 - hanging up with [19](#)

- placing calls with [16](#)
 - using [41](#)
- speed dial
 - configuring [30, 55](#)
 - description of [30](#)
 - labels [55](#)
 - using [17](#)
 - using BLF with [30](#)
- status data, locating [65](#)
- subscriptions, for phone services [56](#)
- suspicious calls, tracing [36](#)
- switching calls [21](#)

T

- TABSynch [55](#)
- transferring, options for [22](#)
- troubleshooting
 - general [65](#)
 - see also QRT

U

- User Options web pages
 - accessing [52](#)
 - configuring features and services with [53](#)
 - subscribing to phone services with [56](#)

V

- voice message indicator
 - changing setting for [58](#)
 - description of [61](#)



Americas Headquarters
Cisco Systems, Inc.
170 West Tasman Drive
San Jose, CA 95134-1706
USA
www.cisco.com
Tel: 408 526-4000
800 553-NETS (6387)
Fax: 408 527-0883

Asia Pacific Headquarters
Cisco Systems, Inc.
168 Robinson Road
#28-01 Capital Tower
Singapore 068912
www.cisco.com
Tel: +65 6317 7777
Fax: +65 6317 7799

Europe Headquarters
Cisco Systems International
BV
Haarlerbergpark
Haarlerbergweg 13-19
1101 CH Amsterdam
The Netherlands
www-europe.cisco.com
Tel: 31 0 800 020 0791
Fax: 31 0 20 357 1100

**Cisco has more than 200 offices worldwide. Addresses, phone numbers, and fax numbers are listed on the
Cisco Website at www.cisco.com/go/offices.**

CCVP, the Cisco Logo, and the Cisco Square Bridge logo are trademarks of Cisco Systems, Inc.; Changing the Way We Work, Live, Play, and Learn is a service mark of Cisco Systems, Inc.; and Access Registrar, Aironet, BPX, Catalyst, CCDA, CCDP, CCIE, CCIP, CCNA, CCNP, CCSP, Cisco, the Cisco Certified Internetwork Expert logo, Cisco IOS, Cisco Press, Cisco Systems, Cisco Systems Capital, the Cisco Systems logo, Cisco Unity, Enterprise/Solver, EtherChannel, EtherFast, EtherSwitch, Fast Step, Follow Me Browsing, FormShare, GigaDrive, HomeLink, Internet Quotient, IOS, iPhone, IP/TV, iQ Expertise, the iQ logo, iQ Net Readiness Scorecard, iQuick Study, LightStream, Linksys, MeetingPlace, MGX, Networking Academy, Network Registrar, *Packet*, PIX, ProConnect, RateMUX, ScriptShare, SlideCast, SMARTnet, StackWise, The Fastest Way to Increase Your Internet Quotient, and TransPath are registered trademarks of Cisco Systems, Inc. and/or its affiliates in the United States and certain other countries.

All other trademarks mentioned in this document or Website are the property of their respective owners. The use of the word partner does not imply a partnership relationship between Cisco and any other company. (0704R)

© 2007 Cisco Systems, Inc. All rights reserved.



The Java logo is a trademark or registered trademark of Sun Microsystems, Inc. in the U.S. or other countries.

