



Call Park

The Call Park feature allows you to place a call on hold, so it can be retrieved from another phone in the Cisco CallManager system (for example, a phone in another office or in a conference room). If you are on an active call at your phone, you can park the call to a call park extension by pressing the Park softkey or the Call Park button. Someone on another phone in your system can then dial the call park extension to retrieve the call.

You can define either a single directory number or a range of directory numbers for use as call park extension numbers. You can park only one call at each call park extension number.

This chapter provides the following information about call park:

- [Introducing Call Park, page 9-1](#)
- [System Requirements for Call Park, page 9-4](#)
- [Interactions and Restrictions, page 9-4](#)
- [Installing and Activating Call Park, page 9-6](#)
- [Configuring Call Park, page 9-6](#)
- [Setting the Service Parameters for Call Park, page 9-7](#)
- [Finding a Call Park Number, page 9-7](#)
- [Configuring a Call Park Number, page 9-9](#)
- [Deleting a Call Park Number, page 9-11](#)
- [Related Topics, page 9-12](#)

Introducing Call Park

The Call Park feature works within a Cisco CallManager cluster, and each Cisco CallManager in a cluster must have call park extension numbers defined. (For information about using call park across clusters, see the [“Using Call Park Across Clusters” section on page 9-2](#).) You can define either a single directory number or a range of directory numbers for use as call park extension numbers. Ensure that the directory number or range of numbers is unique.

Valid call park extension numbers comprise integers and the wildcard character, X. You can configure a maximum of XX in a call park extension number (for example, 80XX), which provides up to 100 call park extension numbers. When a call gets parked, Cisco CallManager chooses the next call park extension number that is available and displays that number on the phone.

Cisco CallManager can park only one call at each call park extension number.



Note

If users will use call park across servers in a cluster, ensure each Cisco CallManager server in a cluster has call park extension numbers that are configured. See the [“Configuring a Call Park Number” section on page 9-9](#) for configuration details.

Using the Call Park Feature

Figure 9-1 illustrates the call park process.

1. User on phone A calls phone B.
2. User on phone A wants to take the call in a conference room for privacy. Phone A user presses the Park softkey.
3. The Cisco CallManager server to which phone A is registered sends the first available call park directory, 1234, which displays on phone A. The user on phone A watches the display for the call park directory number (so he can dial that directory number on phone C).
4. The user on phone A leaves the office and walks to an available conference room where the phone is designated as phone C. The user goes off-hook on phone C and dials 1234 to retrieve the parked call.
5. The system establishes call between phones C and B.

Figure 9-1 Call Park Process

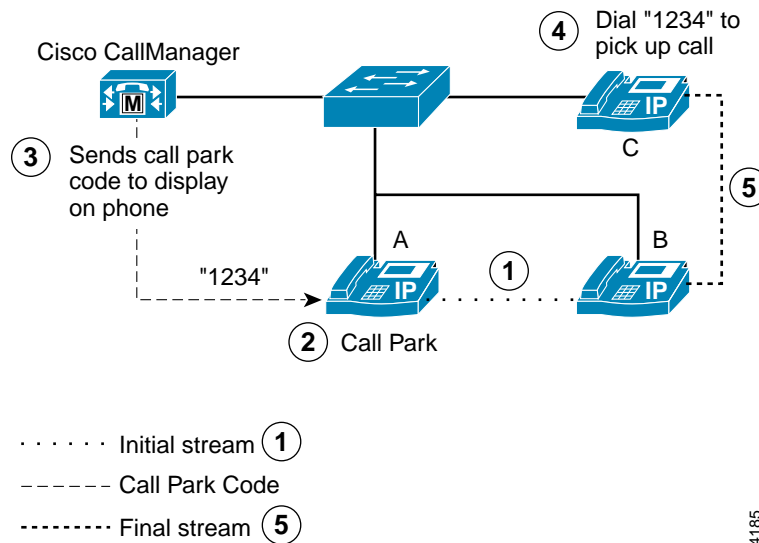

94185

Using Call Park Across Clusters

Users can dial the assigned route pattern (for example, a route pattern for an intercluster trunk could be 80XX) and the call park number (for example 8022) to retrieve parked calls from another Cisco CallManager cluster. Additionally, you must ensure that calling search spaces and partitions are properly configured. See the following example.

Example of Retrieving Parked Calls from Another Cluster

Two clusters exist in the network (cluster A and cluster B). Cluster A includes user A1 and user A2. Cluster B includes user B1 and user B2.

Cluster A includes call park numbers in the range of 81xx. Cluster B includes call park numbers in the range of 82xx, which the administrator configured.

Cluster A includes route patterns that are configured to other cluster park ranges as 82xx (routes to Cluster B). Cluster B includes route patterns that are configured to other cluster park ranges as 81xx (routes to Cluster A).

When user A1 parks a call at 8101, all users (which have correct partitions configured) in Cluster A and Cluster B can retrieve the parked call because of the route pattern configuration. When user B1 parks a call at 8202, all users (which have correct partitions configured) in Cluster A and Cluster B can retrieve the parked call because of the route pattern configuration. See [Figure 9-2](#).

Figure 9-2 Retrieving Parked Calls by Using Intercluster Trunks

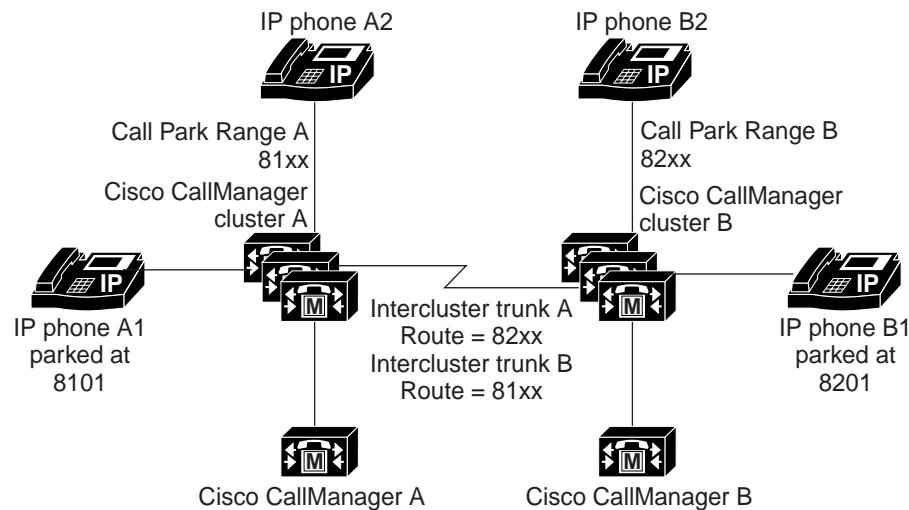

Example 1

1. A1 and A2 talk in connected state.
2. A1 parks call at 8101.
3. B1 dials 8101, call gets routed to cluster A.

Example 2

1. B1 and B2 talk.
2. B1 parks call at 8201.
3. A1 dials 8201 to retrieve parked call.

Intercluster Trunk A includes Route 82xx that accesses Intercluster Trunk to Cluster B

Intercluster Trunk B includes Route 81xx that accesses Intercluster Trunk to Cluster A

Note: Users do not have control of the parked call number; the system assigns the number.

99551

System Requirements for Call Park

To operate, call park requires the following software component:

- Cisco CallManager 5.0

The following SCCP and SIP phones support call park with the Park softkey in the Standard User and Standard Feature softkey templates:

- Cisco IP Phones (models 7941, 7961, 7970, 7971)

The following SCCP phones support call park with the Park softkey in the Standard User and Standard Feature softkey templates:

- Cisco IP Phones (models 7905, 7912, 7920, 7940, 7960)

The following SCCP phones support call park with the Call Park button on the phone button template:

- Cisco IP Phone model 30 (30 SP+ and 30 VIP)
- Cisco IP Phone model 12 (12 S, 12 SP, 12 SP+)
- Cisco IP Phone model 7910

Interactions and Restrictions

The following sections describe the interactions and restrictions for call park:

- [Interactions, page 9-4](#)
- [Restrictions, page 9-6](#)

Interactions

The following sections describe how call park interacts with Cisco CallManager applications and call processing:

- [CTI Applications, page 9-4](#)
- [Music On Hold, page 9-5](#)
- [Route Plan Report, page 9-5](#)
- [Calling Search Space and Partitions, page 9-5](#)
- [Immediate Divert, page 9-5](#)
- [Barge, page 9-5](#)

CTI Applications

CTI applications (for example, Attendant Console) access call park functionality, including monitoring activity on call park DN. To monitor a call park DN, an application or end user that is associated with the CTI application must be added to the Standard CTI Allow Call Park Monitoring user group.

Refer to the [“Configuration Checklist for Cisco CallManager Attendant Console”](#) section on page 16-16 for details.

Music On Hold

Music on hold allows users to place calls on hold with music that a streaming source provides. Music on hold allows two types of hold:

- User hold—The system invokes this type of hold when a user presses the Hold button or Hold softkey.
- Network hold—This type of hold takes place when a user activates the transfer, conference, or call park feature, and the hold automatically gets invoked.

Route Plan Report

The route plan report displays the patterns and directory numbers that are configured in Cisco CallManager. Use the route plan report to look for overlapping patterns and directory numbers before assigning a directory number to call park. Refer to the [Route Plan Report](#) chapter in the *Cisco CallManager Administration Guide*.

Calling Search Space and Partitions

Assign the Call Park directory number or range to a partition to limit call park access to users on the basis of the device calling search space. See [Calling Search Space Configuration](#) and [Partition Configuration](#) in the *Cisco CallManager Administration Guide*.

Immediate Divert

Call park supports Immediate Divert (iDivert softkey). For example, user A calls user B, and user B parks the call. User B retrieves the call and then decides to send the call to voice-messaging mailbox by pressing the iDivert softkey. User A receives the voice-messaging mailbox greeting of user B.

Barge

The following paragraphs describe the differences between Barge and cBarge with call park.

Barge with Call Park

The target phone (the phone that is being barged upon) controls the call. The barge initiator “piggy backs” on the target phone. The target phone includes most of the common features, even when the target is being barged; therefore, the barge initiator has no feature access. When the target parks a call, the barge initiator then must release its call (the barge).

cBarge with Call Park

The target and barge initiator act as peers. The cBarge feature uses a conference bridge, which makes it behave similar to a MeetMe conference. Both phones (target and barge initiator) have full access to their features.

Restrictions

The following restrictions apply to call park:

- Cisco CallManager can park only one call at each call park extension number.
- Ensure each call park directory number, partition, and range is unique within the Cisco CallManager cluster.
- Each Cisco CallManager to which devices are registered needs its own unique call park directory number and range.
- Cisco IP Phone 7902 cannot park a call (retrieval of parked calls only).

See the [“Configuring a Call Park Number” section on page 9-9](#) for configuration details.

Installing and Activating Call Park

Call park, a system feature, comes standard with Cisco CallManager software. It does not require special installation.

Configuring Call Park

This section contains the following information:

- [Call Park Configuration Checklist, page 9-6](#)
- [Setting the Service Parameters for Call Park, page 9-7](#)
- [Finding a Call Park Number, page 9-7](#)
- [Configuring a Call Park Number, page 9-9](#)
- [Deleting a Call Park Number, page 9-11](#)
- [Troubleshooting Call Park, page 9-11](#)

Call Park Configuration Checklist

[Table 9-1](#) provides a checklist to configure Call Park.

Table 9-1 Call Park Configuration Checklist

Configuration Steps		Related procedures and topics
Step 1	Configure a partition for call park extension numbers to make partition available only to users who have the partition in their calling search space.	Configuring a Partition, Cisco CallManager Administration Guide Media Termination Point Configuration, Cisco CallManager Administration Guide
Step 2	Configure a unique call park number or define a range of call park extension numbers for each Cisco CallManager in the cluster.	Configuring a Call Park Number, page 9-9

Table 9-1 Call Park Configuration Checklist (continued)

Configuration Steps		Related procedures and topics
Step 3	Add all servers that call park uses to the appropriate Cisco CallManager group. Note Servers and Cisco CallManagers get configured during installation.	Cisco CallManager Group Configuration , <i>Cisco CallManager Administration Guide</i>
Step 4	Assign the Standard User softkey template to each device that has call park access. For phones that do not use softkeys, the phone button template with the Call Park button automatically gets configured.	Softkey Template Configuration , <i>Cisco CallManager Administration Guide</i>
Step 5	In the User Group Configuration window, assign application and end users to the Standard CTI Allow Call Park Monitoring user group. This applies only to users associated with CTI applications requiring Call Park monitoring capability (for example, Attendant Console).	Adding Users to a User Group , <i>Cisco CallManager Administration Guide</i>
Step 6	Notify users that the call park feature is available.	Refer to the phone documentation for instructions on how users access call park features on their Cisco IP Phone.

Setting the Service Parameters for Call Park

Cisco CallManager provides two clusterwide service parameters for call park: Call Park Display Timer and Call Park Reversion Timer. Each service parameter includes a default and requires no special configuration.

- Call Park Display Timer—Default specifies 10 seconds. This parameter determines how long a call park number displays on the phone that parked the call. Set this timer for each server in a cluster that has the Cisco CallManager service and call park configured.
- Call Park Reversion Timer—Default specifies 60 seconds. This parameter determines the time that a call remains parked. Set this timer for each server in a cluster that has the Cisco CallManager service and call park configured. When this timer expires, the parked call returns to the device that parked the call.



Note

To set the timers, choose **System > Service Parameters** and update the Call Park Display Timer and the Call Park Reversion Timer fields in the **Clusterwide Parameters (Feature-General)** pane.

Finding a Call Park Number

Because you may have several call park numbers in your network, Cisco CallManager lets you locate specific call park numbers on the basis of specific criteria. Use the following procedure to locate call park numbers.

**Note**

During your work in a browser session, Cisco CallManager Administration retains your call park number search preferences. If you navigate to other menu items and return to this menu item, Cisco CallManager Administration retains your call park number search preferences until you modify your search or close the browser.

Procedure**Step 1** Choose **Call Routing > Call Park**.

The Find and List Call Park Numbers window displays. Use the two drop-down list boxes to search for a call park number.

Step 2 From the first Find Call Park Numbers where drop-down list box, choose one of the following criteria:

- Number
- Partition
- Description
- CallManager

**Note**

The criterion that you choose in this drop-down list box specifies how the list of call park numbers that your search generates will be sorted.

From the second Find Call Park Numbers where drop-down list box, choose one of the following criteria:

- begins with
- contains
- ends with
- is exactly
- is empty
- is not empty

Step 3 Specify the appropriate search text, if applicable, and click **Find**. You can also specify how many items per page to display.**Tip**

To find all call park numbers that are registered in the database, click **Find** without entering any search text.

A list of discovered call park numbers displays by

- Call Park Number icon
- Call Park Number
- Partition
- Description
- CallManager

- Step 4** From the list of records, click the Call Park Number that matches your search criteria. The window displays the call park number that you choose.
-

Additional Information

See the [“Related Topics” section on page 9-12](#).

Configuring a Call Park Number

This section describes how to add, copy, and update a single call park extension number or range of extension numbers.

Procedure

- Step 1** Choose **Call Routing > Call Park**.
- Step 2** Perform one of the following tasks:
- To add a new Call Park Number, click **Add New**.
 - To copy a Call Park Number, use the procedure in the [“Finding a Call Park Number” section on page 9-7](#) to locate the call park number or range of numbers. Click the Copy icon.
 - To update a Call Park Number, use the procedure in the [“Finding a Call Park Number” section on page 9-7](#) to locate the call park number or range of numbers.
- The Call Park Number Configuration window displays.
- Step 3** Enter or update the appropriate settings as described in [Table 9-2](#).
- Step 4** To save the new or changed call park numbers in the database, click **Save**.
-

Additional Information

See the [“Related Topics” section on page 9-12](#).

Call Park Configuration Settings

Table 9-2 describes the call park configuration settings. For related procedures, see the “[Related Topics](#)” section on page 9-12.

Table 9-2 Call Park Configuration Settings

Field	Description
Call Park Number/Range	<p>Enter the call park extension number. You can enter literal digits or the wildcard character X (the system allows one or two Xs). For example, enter 5555 to define a single call park extension number of 5555 or enter 55XX to define a range of call park extension numbers from 5500 to 5599.</p> <p>Note You can create a maximum of 100 call park numbers with one call park range definition. Make sure that the call park numbers are unique.</p> <p>Note You cannot overlap call park numbers between Cisco CallManager servers. Ensure that each Cisco CallManager server has its own number range.</p>
Description	<p>Provide a brief description of this call park number.</p>
Partition	<p>If you want to use a partition to restrict access to the call park numbers, choose the desired partition from the drop-down list box. If you do not want to restrict access to the call park numbers, choose <None> for the partition.</p> <p>You can configure the number of partitions that display in this drop-down list box by using the Max List Box Items enterprise parameter. If more partitions exist than the Max List Box Items enterprise parameter specifies, the ellipsis button (...) displays next to the drop-down list box. Click the ... button to display the Select Partition window. Enter a partial partition name in the List items where Name contains field. Click the desired partition name in the list of partitions that displays in the Select item to use box and click OK.</p> <p>Note To set the maximum list box items, choose System > Enterprise Parameters and update the Max List Box Items field under CCMAdmin Parameters.</p> <p>Note Make sure that the combination of call park extension number and partition is unique within the Cisco CallManager cluster.</p>
Cisco CallManager	<p>Using the drop-down list box, choose the Cisco CallManager to which these call park numbers apply.</p> <p>Note You can create a maximum of 100 call park numbers with one call park range definition. Make sure that the call park numbers are unique.</p> <p>Note You cannot overlap call park numbers between Cisco CallManager servers. Ensure that each Cisco CallManager server has its own number range.</p>

Deleting a Call Park Number

This section describes how to delete call park numbers from the Cisco CallManager database.

Procedure

-
- Step 1** Using the procedure in the [“Finding a Call Park Number”](#) section on page 9-7, locate the call park number or range of numbers.
- Step 2** Click the call park number or range of numbers that you want to delete.
- Step 3** Click **Delete**.



Note You can delete multiple call park numbers from the Find and List Call Park Numbers window by checking the check boxes next to the appropriate call park numbers and clicking **Delete Selected**. You can delete all call park numbers in the window by clicking **Select All** and then clicking **Delete Selected**.

Additional Information

See the [“Related Topics”](#) section on page 9-12.

Troubleshooting Call Park

[Table 9-3](#) provides troubleshooting recovery tips for common call park problems.

Table 9-3 *Troubleshooting Tips for Call Park*

Problem Description	Recommended Action
User cannot park calls. When the user presses the Park softkey or feature button, the call does not get parked.	Ensure that a unique call park number is assigned to each Cisco CallManager in the cluster. See the “Configuring a Call Park Number” section on page 9-9. The partition that is assigned to the call park number does not match the partition that is assigned to the phone directory number. See the “Configuring a Call Park Number” section on page 9-9 and the “Configuring a Directory Number” section in the <i>Cisco CallManager Administration Guide</i> .
The call park number does not display long enough for the user.	Set the Call Park Display Timer to a longer duration. See the “Setting the Service Parameters for Call Park” section on page 9-7.

Additional Information

See the [“Related Topics”](#) section on page 9-12.

Related Topics

- [Call Park](#), page 9-1
- [Configuring a Call Park Number](#), page 9-9
- [Finding a Call Park Number](#), page 9-7
- [Deleting a Call Park Number](#), page 9-11
- [Troubleshooting Call Park](#), page 9-11
- [Phone Button Template Configuration](#), *Cisco CallManager Administration Guide*
- [Cisco IP Phone Configuration](#), *Cisco CallManager Administration Guide*
- [Partition Configuration](#), *Cisco CallManager Administration Guide*
- [Media Termination Point Configuration](#), *Cisco CallManager Administration Guide*
- [Route Plan Report](#), *Cisco CallManager Administration Guide*
- [Softkey Template Configuration](#), *Cisco CallManager Administration Guide*
- [End User Configuration](#), *Cisco CallManager Administration Guide*
- [User Group Configuration](#), *Cisco CallManager Administration Guide*
- [Clustering](#), *Cisco CallManager System Guide*
- *Cisco IP Phone Administration Guide for Cisco CallManager*
- [Cisco IP Phone user documentation and release notes \(all models\)](#)