



## Understanding Redundancy

---

Cisco CallManager (release 3.0 and later) provides several forms of redundancy:

- Database redundancy—The Cisco CallManagers in a cluster maintain backup copies of their shared database. See the “Clusters” section on page 2-1.
- Call processing redundancy—Using Cisco CallManager groups, you can designate backup Cisco CallManagers to handle call processing for a disabled Cisco CallManager.

The following procedure describes how to configure call processing redundancy using Cisco CallManager groups:

- Configuring Call Processing Redundancy, page 3-5

## Groups and Clusters

Groups and clusters are logical collections of Cisco CallManagers and their associated devices. Groups and clusters are not necessarily related to the physical locations of any of their members.

A cluster is a set of Cisco CallManagers that share a common database. You specify which servers and which Cisco CallManagers belong to the same cluster and specify the publisher database location when you install and configure the Cisco CallManager software. For more information on clusters, refer to the installation and configuration instructions that shipped with your Cisco CallManager.

A group is a list of Cisco CallManagers that is assigned to one or more device pools to provide redundant call processing. You use Cisco CallManager Administration to define the groups, specify which Cisco CallManagers belong to each group, and to assign a Cisco CallManager group to each device pool.

## Components of a Group

A Cisco CallManager group is a prioritized list of up to three Cisco CallManagers. Each group must contain a primary Cisco CallManager, and it may contain one or two standby Cisco CallManagers. The order that the Cisco CallManagers are listed in a group determines the failover order.

Under normal operation, the primary Cisco CallManager in a group controls call processing for all the registered devices (such as phones and gateways) associated with a group.

If the primary Cisco CallManager fails for any reason, the first standby Cisco CallManager takes control of the devices that were registered with the primary Cisco CallManager. If you specify a second standby Cisco CallManager for the group, it takes control of the devices if both the primary and the first standby Cisco CallManagers fail.

You associate devices to a Cisco CallManager group by using device pools. Each device belongs to one device pool, and each device pool is associated with one Cisco CallManager group. You can combine the groups and device pools in various ways to achieve the desired level of redundancy. For example, Figure 3-1 shows a simple system with three redundant Cisco CallManagers controlling 800 devices.

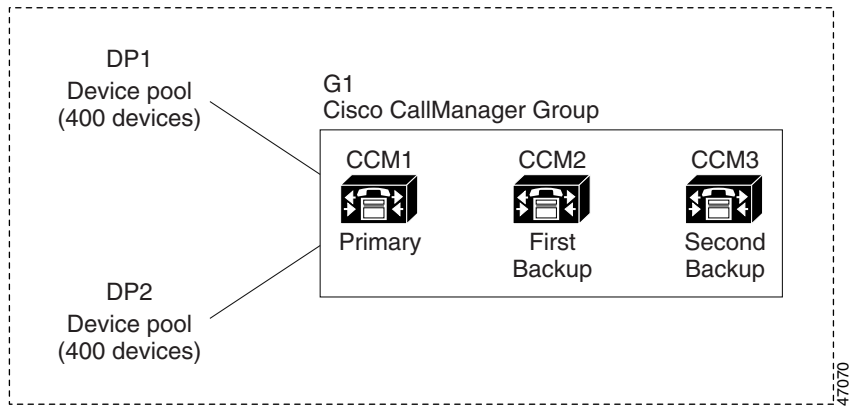
**Figure 3-1 Example of a Cisco CallManager Group**

In Figure 3-1, Cisco CallManager group G1 is assigned to two device pools, DP1 and DP2. CCM1, as the primary Cisco CallManager in group G1, controls all 800 devices in DP1 and DP2 under normal operation. If CCM1 fails, control of all 800 devices transfers to CCM2. If CCM2 also fails, then control of all 800 devices transfers to CCM3.

## Combining Redundancy with Distributed Call Processing

The configuration in Figure 3-1 provides call processing redundancy, but it does not distribute the call processing load very well among the three Cisco CallManagers in the example. In most cases, you would want to distribute the devices in a way that prevents a single Cisco CallManager from becoming overloaded if one of the other Cisco CallManagers in the group fails. Figure 3-2 shows one possible way to configure the Cisco CallManager groups and device pools to achieve both distributed call processing and redundancy for a system of three Cisco CallManagers and 800 devices.

**Figure 3-2 Example of Redundancy Combined with Distributed Call Processing**

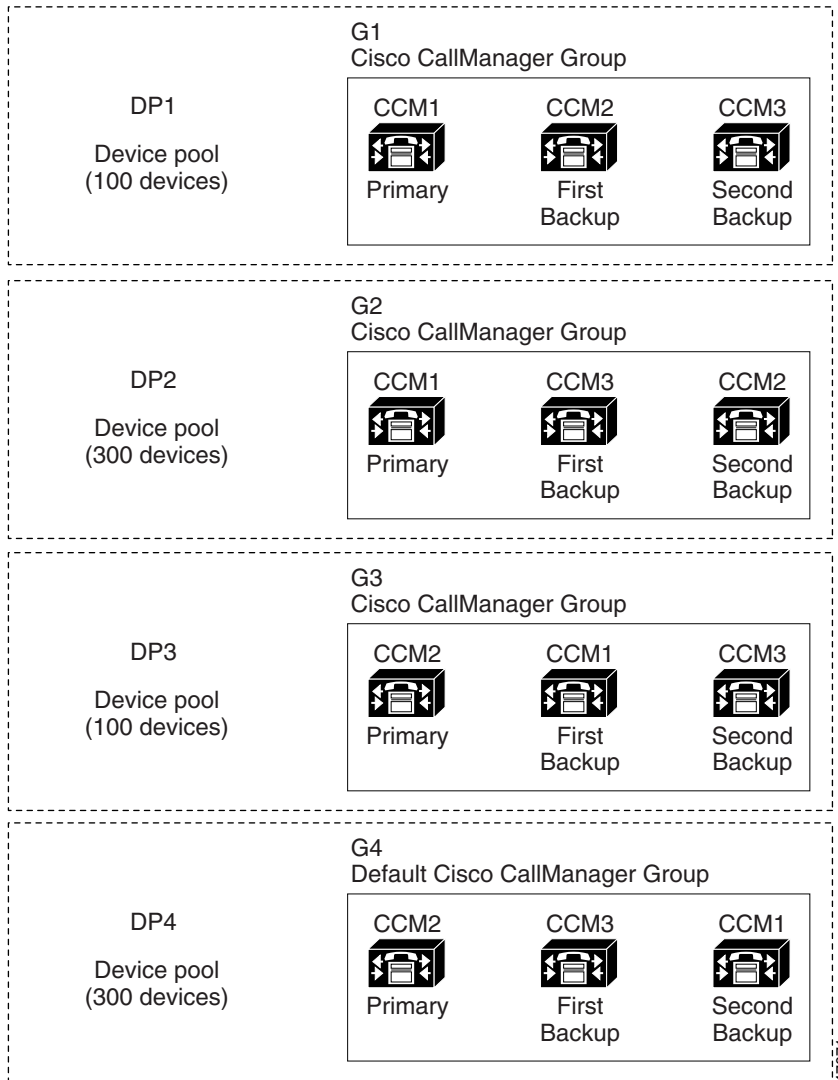

In Figure 3-2, the Cisco CallManager groups are configured and assigned to device pools so that Cisco CallManager CCM1 is the primary controller in two groups, G1 and G2. If CCM1 fails, the 100 devices in device pool DP1 transfer to CCM2, and the 300 devices in DP2 transfer to CCM3. Similarly, CCM2 is the primary controller of groups G3 and G4. If CCM2 fails, the 100 devices in DP3 transfer to CCM1, and the 300 devices in DP4 transfer to CCM3. If CCM1 and CCM2 both fail, all devices transfer to CCM3.

For more information on distributed call processing, see the “Understanding Distributed Call Processing” section on page 2-1.

## Configuring Call Processing Redundancy

This section describes the general steps for configuring Cisco CallManager groups to provide call processing redundancy and distributed call processing as illustrated by the example in Figure 3-2.

### Before You Begin

Install the Cisco Media Convergence Servers and Cisco CallManager software to form a cluster of Cisco CallManagers. A cluster is a set of Cisco CallManagers that share the same database. In Figure 3-2, the cluster consists of Cisco CallManagers CCM1, CCM2, and CCM3. For details, refer to the installation instructions that shipped with your Cisco CallManager.

### Procedure

---

**Step 1** In Cisco CallManager Administration, select **System > Cisco CallManager** and update the configuration for the Cisco CallManagers in a cluster.

When you install the Cisco CallManager software, the database contains an initial configuration for each of the Cisco CallManagers in the cluster. However, you might want to update these configurations to change the settings for some of the parameters such as auto-registration. For details, see the “Updating a Cisco CallManager” section on page 12-5.

**Step 2** In Cisco CallManager Administration, select **System > Cisco CallManager Group** to configure Cisco CallManager groups for the cluster.

The Default group is configured automatically when you install the Cisco CallManager software, and devices that auto-register with Cisco CallManager are normally assigned to this Default group. However, you might want to change the configuration of the Default group or specify one of the other groups as the default group for auto-registration. For details, see the “Configuring Cisco CallManager Groups” section on page 13-1.

**Step 3** In Cisco CallManager Administration, select **System > Device Pool** to configure device pools for your system.

- a. The Default device pool is configured automatically when you install Cisco CallManager. However, you might want to update its configuration to set the parameters such as region and to assign this pool to the appropriate Cisco Call Manager group. Cisco CallManager normally assigns the Default device pool to devices that auto-register with it, unless you specify a different default device pool through the Device Defaults (see the “Setting Device Defaults” section on page 15-1).
- b. Configure the other device pools and assign them to the appropriate Cisco CallManager groups. In this example, device pool DP1 is assigned to group G1, DP2 is assigned to G2, and so forth.

For details, see the “Configuring Device Pools” section on page 17-1.

**Step 4** In Cisco CallManager Administration, select the desired options under **Device** to configure the devices on your network and to assign them to the appropriate device pools.

**Step 5** After making your configuration changes and saving them in the database, restart the devices affected by those changes.

---

### Related Topics

Cisco CallManager groups provide both call processing redundancy and distributed call processing. The way you distribute devices, device pools, and Cisco CallManagers among the groups is critical for maintaining the desired level of redundancy and load balancing in your system.

For more information on distributed call processing, see:

- Understanding Distributed Call Processing, page 2-1.