



Cisco BTS 10200 Softswitch Routing and Dial Plan Guide, Release 6.0.1

December 9, 2008

Americas Headquarters

Cisco Systems, Inc.
170 West Tasman Drive
San Jose, CA 95134-1706
USA
<http://www.cisco.com>
Tel: 408 526-4000
800 553-NETS (6387)
Fax: 408 527-0883

Text Part Number: OL-15637-04

THE SPECIFICATIONS AND INFORMATION REGARDING THE PRODUCTS IN THIS MANUAL ARE SUBJECT TO CHANGE WITHOUT NOTICE. ALL STATEMENTS, INFORMATION, AND RECOMMENDATIONS IN THIS MANUAL ARE BELIEVED TO BE ACCURATE BUT ARE PRESENTED WITHOUT WARRANTY OF ANY KIND, EXPRESS OR IMPLIED. USERS MUST TAKE FULL RESPONSIBILITY FOR THEIR APPLICATION OF ANY PRODUCTS.

THE SPECIFICATIONS AND INFORMATION REGARDING THE PRODUCTS IN THIS MANUAL ARE SUBJECT TO CHANGE WITHOUT NOTICE. ALL STATEMENTS, INFORMATION, AND RECOMMENDATIONS IN THIS MANUAL ARE BELIEVED TO BE ACCURATE BUT ARE PRESENTED WITHOUT WARRANTY OF ANY KIND, EXPRESS OR IMPLIED. USERS MUST TAKE FULL RESPONSIBILITY FOR THEIR APPLICATION OF ANY PRODUCTS.

THE SOFTWARE LICENSE AND LIMITED WARRANTY FOR THE ACCOMPANYING PRODUCT ARE SET FORTH IN THE INFORMATION PACKET THAT SHIPPED WITH THE PRODUCT AND ARE INCORPORATED HEREIN BY THIS REFERENCE. IF YOU ARE UNABLE TO LOCATE THE SOFTWARE LICENSE OR LIMITED WARRANTY, CONTACT YOUR CISCO REPRESENTATIVE FOR A COPY.

The Cisco implementation of TCP header compression is an adaptation of a program developed by the University of California, Berkeley (UCB) as part of UCB's public domain version of the UNIX operating system. All rights reserved. Copyright © 1981, Regents of the University of California.

NOTWITHSTANDING ANY OTHER WARRANTY HEREIN, ALL DOCUMENT FILES AND SOFTWARE OF THESE SUPPLIERS ARE PROVIDED "AS IS" WITH ALL FAULTS. CISCO AND THE ABOVE-NAMED SUPPLIERS DISCLAIM ALL WARRANTIES, EXPRESSED OR IMPLIED, INCLUDING, WITHOUT LIMITATION, THOSE OF MERCHANTABILITY, FITNESS FOR A PARTICULAR PURPOSE AND NONINFRINGEMENT OR ARISING FROM A COURSE OF DEALING, USAGE, OR TRADE PRACTICE.

IN NO EVENT SHALL CISCO OR ITS SUPPLIERS BE LIABLE FOR ANY INDIRECT, SPECIAL, CONSEQUENTIAL, OR INCIDENTAL DAMAGES, INCLUDING, WITHOUT LIMITATION, LOST PROFITS OR LOSS OR DAMAGE TO DATA ARISING OUT OF THE USE OR INABILITY TO USE THIS MANUAL, EVEN IF CISCO OR ITS SUPPLIERS HAVE BEEN ADVISED OF THE POSSIBILITY OF SUCH DAMAGES.

CCDE, CCENT, Cisco Eos, Cisco Lumin, Cisco Nexus, Cisco StadiumVision, Cisco TelePresence, Cisco WebEx, the Cisco logo, DCE, and Welcome to the Human Network are trademarks; Changing the Way We Work, Live, Play, and Learn and Cisco Store are service marks; and Access Registrar, Aironet, AsyncOS, Bringing the Meeting To You, Catalyst, CCDA, CCDP, CCIE, CCIP, CCNA, CCNP, CCSP, CCVP, Cisco, the Cisco Certified Internetwork Expert logo, Cisco IOS, Cisco Press, Cisco Systems, Cisco Systems Capital, the Cisco Systems logo, Cisco Unity, Collaboration Without Limitation, EtherFast, EtherSwitch, Event Center, Fast Step, Follow Me Browsing, FormShare, GigaDrive, HomeLink, Internet Quotient, IOS, iPhone, iQuick Study, IronPort, the IronPort logo, LightStream, Linksys, MediaTone, MeetingPlace, MeetingPlace Chime Sound, MGX, Networkers, Networking Academy, Network Registrar, PCNow, PIX, PowerPanels, ProConnect, ScriptShare, SenderBase, SMARTnet, Spectrum Expert, StackWise, The Fastest Way to Increase Your Internet Quotient, TransPath, WebEx, and the WebEx logo are registered trademarks of Cisco Systems, Inc. and/or its affiliates in the United States and certain other countries.

All other trademarks mentioned in this document or website are the property of their respective owners. The use of the word partner does not imply a partnership relationship between Cisco and any other company. (0809R)

Any Internet Protocol (IP) addresses used in this document are not intended to be actual addresses. Any examples, command display output, and figures included in the document are shown for illustrative purposes only. Any use of actual IP addresses in illustrative content is unintentional and coincidental.

Cisco BTS 10200 Softswitch Routing and Dial Plan Guide, Release 6.0.1
© 2008 Cisco Systems, Inc. All rights reserved.



CONTENTS

Preface **xiii**

- Introduction **xiii**
- Organization **xiii**
- Obtaining Documentation and Submitting a Service Request **xiv**
- Document Change History **xiv**

CHAPTER 1

Digit Translations **1-1**

- Introduction **1-1**
- Digit Manipulation **1-3**
 - Character Function **1-4**
 - Caret (^) Character **1-5**
 - Dollar Sign (\$) Character **1-5**
 - Dot (.) Character **1-6**
 - Question Mark (?) Character **1-7**
 - Percent (%) Character (Match and Replace) **1-8**
 - Ampersand (&) Character **1-10**
 - Delete Digits Function **1-11**
 - Deletion of Leading Digits **1-11**
 - Deletion of Specific Leading Digits **1-11**
 - Deletion of Trailing Digits **1-12**
 - Deletion of Specific Trailing Digits **1-12**
 - Deletion of Leading Digits Only If the Length Matches **1-12**
 - Deletion of Trailing Digits Only If the Length Matches **1-13**
 - Prefix Digits Function **1-13**
 - Prefix Leading Digits **1-13**
 - Prefixing of Digits Only If Length Matches **1-13**
 - Replace (Delete and Prefix) Digits Function **1-14**
 - Replacement of Leading Digits **1-14**
 - Replacement of Trailing Digits **1-14**
 - Replacement of Specific Digits **1-15**
 - Replacement of Leading Digits Only If Length Matches **1-15**
 - Replacement of Specific Digits In a Specific Digit Position **1-15**
 - Replacement of Digits In a Specific Digit Position **1-16**
 - Replacement of Digits Only If Null **1-16**

- Replacement of Any Input String 1-17
- Nature of Address Manipulation 1-18
 - Nature of Address Route Profile 1-19
 - Nature of Address Route 1-19
- ANI or DNI Service Manipulation 1-20
 - Pretranslation Stage 1-20
 - Determining NOA for China 1-21
 - Digit Manipulation Profile 1-21
 - Digit Manipulation 1-21
 - Dial Plan Profile 1-22
 - International Dial Plan Profile 1-22
 - Translations Stage 1-22
 - Dial Plan 1-22
 - International Dial Plan 1-22
 - Variable Digit Dialing 1-23
 - Variable Digit Dialing Provisioning 1-23
- Routing Stage 1-23
 - Destination 1-24
 - Route 1-24
 - Trunk Group 1-24
 - Policy NXX 1-24
 - Call Type Profile 1-25
- Sample Provisioning 1-26
- Feature Interaction 1-27

CHAPTER 2

Routing 2-1

- Introduction 2-1
- Routing Types 2-2
 - Basic Subscriber Routing 2-3
 - Basic Trunk Routing 2-4
 - Service Provider Routing 2-6
 - Carrier Based Routing 2-7
 - Basic Dial Plan Routing 2-9
 - ANI Based Routing 2-12
 - NOA Routing (ITU Local Number Portability) 2-12
 - Routing Number 2-13
 - Switch Types 2-13
 - Query Types 2-13
 - Query on Release 2-17

Intermediate or Donor Switch Performing QoR for Another Switch or Network	2-19
QoR and Call Forwarding	2-20
Onward Donor Based Routing	2-20
Subscriber Based LNP Trigger on a Donor Switch	2-20
Precedence of Query Types	2-23
Dial Plan and NOA Routing	2-25
Cluster Routing	2-26
Subscriber Originated Call at CMS	2-27
Call Processing at Terminating CMS/MGC	2-28
Inbound Call Processing at MGC from PSTN	2-29
Support for ietf Trunk Group Draft	2-29
Define DN as a Cluster LRN	2-29
Define Cluster Dial Plan ID	2-30
Define Intracluster TG Flag	2-30
Softswitch Trunk Group Profile Table	2-30
SIP-INBOUND-POLICY-PROFILE Table	2-30
On-Net Routing and LNP for Inter-CMS Routing	2-31
On-Net Routing	2-31
Inter-CMS Routing	2-34
ANSI LNP Query Support for Carrier Calls	2-35
LNP Query for On-net Routing, Inter-CMS Routing	2-36
Destination NANP-LNP-QUERY Value UNCONDITIONAL-LNP-TRIGGER-QUERY	2-39
On-net Route Bypass of Carrier Route	2-40
Remove LNP Query Result Data When Carrier LNP-QUERY= N	2-42
Ignore Inbound LNP Information	2-43
On-net Routing Use Case Matrix	2-44
Feature Interactions	2-59
Configuring	2-59
Destination	2-63
Carrier Existing LNP-QUERY=Y/N	2-63
Call Type Profile	2-63
LNP-QUERY	2-64
International WZ1 (INTL_WZ1) Preferred Carrier Routing	2-64
Call Types	2-66
1+ InterLATA Call	2-66
1+ IntraLATA Call	2-67
0+ InterLATA Call	2-68
0+ IntraLATA Call	2-69
Ported-In Call Processing	2-71
Operator Services	2-73

- Prerequisites 2-73
- Supported Interfaces 2-73
- Provisioning Operator Services 2-74
- Policy-Based Flexible Routing 2-75
 - Day of Year, Day of Week, and Time of Day Policy 2-77
 - Origin Dependent Routing Policy 2-77
 - Originating Line Information Policy 2-77
 - NXX Policy 2-78
 - Percent Policy 2-78
 - Point of Presence Policy 2-78
 - Prefix Policy 2-78
 - Region Profile 2-78
 - Region Policy 2-79
 - Call Type Policy 2-79
 - Circuit Code Policy 2-79
 - Server Policy 2-79

CHAPTER 3

Local Exchange Routing Guide 3-1

- Introduction 3-1
- Local Exchange Routing Guide Support 3-1
 - LERG6 Update 3-2
 - LERG6INS Update 3-3
 - LERG6INS Time Schedule 3-5
 - System Context for LERG Support 3-5
 - Configuring 3-5
 - Operator Interfaces 3-6
 - CLI Commands 3-6
 - LERG6 Table 3-7
 - LERG6-INS Table 3-8
- LERG, TNS, and Additional SIP Extensions for CMS-MGC Separation 3-9
 - LERG 3-9
 - TNS Routing Modifications 3-13
 - Current TNS Routing Implementation 3-13
 - Modified TNS Routing Implementation 3-13
 - TNS and LERG Feature Use 3-15
 - Data Model Changes to Policy Routing Tables 3-16
 - Inter-Process Interface (SIA) 3-17
 - Call Type 3-17
 - Nature of Address 3-17

Calling Party Category	3-18
Dial Around Indicator	3-18
EMS Changes	3-19
TNS Routing Modification	3-19
Default Routing	3-20
Validation Digits and Finding Call Type with LERG Data	3-20
Circuit Code Policy Routing	3-22
Call Type Policy Routing	3-22
TNS Routing Modifications	3-24
Setting Up LERG Validation and Call_Type	3-24
Setting Up Call_Type Policy	3-24
Setting Up Circuit_Code Policy	3-25
Softswitch Trunk Group Profile Table	3-25
North American Numbering Plan Administration State Table	3-25
LERG6 Table	3-25
Policy Circuit Code Table	3-26
Policy Profile Table	3-26
Policy Call Type Table	3-26
Dial Plan Profile Table	3-26

CHAPTER 4**Electronic Number Mapping and Routing 4-1**

Introduction	4-1
ENUM Capability	4-1
ENUM Support for Routing	4-1
Performing the ENUM Query	4-2
Routing Upon Receipt of the ENUM Response	4-2
Call Routing Based on the Received URI	4-2
Call Routing If the Cisco BTS 10200 Does Not Receive a URI or Receives a No Response message	4-3
ENUM Routing Use Cases	4-3
Selecting Inter-CMS Trunks	4-3
Selecting a SIP Trunk to a Route Proxy	4-4
Selecting a SIP Trunk to an SBC	4-5
ENUM Support for LNP Data	4-6
Cisco BTS 10200 Routing Operations	4-7
Cisco BTS 10200 Receives the NPDI Indicator and LRN Information	4-7
Cisco BTS 10200 Receives Only Npdi Indicator	4-7
Cisco BTS 10200 Receives the NPDI Indicator, LRN and URI	4-7
Operational Recommendations for Porting Procedures	4-7
Porting In a DN	4-8

- Porting Out a DN 4-8
- Porting a DN to a Different Node 4-8
- ENUM Clients Operation 4-8
 - Launching the ENUM query 4-9
 - Filtering the Response 4-9
 - Supporting Multiple Roots 4-10
 - Supporting Multiple ENUM Servers 4-11
 - Monitoring ENUM servers and Measuring Latency 4-11
- Prerequisites 4-11

CHAPTER 5

Dial Plans and Routing 5-1

- Introduction 5-1
- Originating Basic Call State Machine (CS2 Call Model) 5-2
- Cisco BTS 10200 Feature Server Strategy 5-3
- Point of Presence 5-4
- Network Configuration 5-5
- Subscriber Types 5-6
 - Individual 5-6
 - Centrex 5-6
 - Interactive Voice Response 5-6
 - Multi-line Hunt Group 5-6
 - Private Branch Exchange 5-6
 - Remote Activation of Call Forwarding 5-6
- Digit Collection 5-7
- Dial Plans 5-8
 - National Dial Plan 5-8
 - International Dial Plan 5-8
 - Variable Digit Dialing 5-9
 - Variable Digit Dialing Provisioning 5-9
 - Custom Dial Plan 5-9
- Digit Manipulation 5-9
- Digit Analysis 5-10
 - Destination 5-10
 - Call Type 5-10
 - Route Guide 5-10
 - Route 5-10
 - Carrier 5-10
 - Local Service Area 5-12

Class of Service Screening	5-13
Routing	5-14
Office Code	5-14
Ported Office Code	5-14
Route Guide	5-14
Route	5-14
Trunk Group	5-15
Trunk Group Types	5-15
Announcement	5-15
Channel Associated Signaling	5-15
Integrated Services Digital Network	5-16
Signaling System 7	5-16
Session Initiation Protocol	5-16
Generic Address Parameter Based Routing	5-16
Tandem Provisioning	5-17
Automatic Number Identification	5-17
Automatic Number Identification Screening	5-17
Automatic Number Identification Screening Profile	5-17
Cause Code Map	5-18
Cause Code Map Profile	5-18
H.323 Gateway	5-18
H.323 Gateway to Gatekeeper	5-18
H.323 Terminal	5-18
H.323 Terminal Profile	5-18
H.323 Trunk Group Profile	5-19
II White Black List	5-19
Service Provider	5-19
Technical Prefix Group	5-19
Technical Prefix Group Profile	5-19
Trunk Group Feature Data	5-20
Trunk Group Service Profile	5-20
Local Toll-Free Service Provisioning	5-20
Local Toll-Free Database	5-21
Service Control Point-Based Toll-Free Services	5-21
Automatic Number Identification White/Black List	5-21
Customer Group	5-21
DN2 Customer Group	5-22
II Restrict List	5-22
Carriers and Service Providers	5-23

- Carrier 5-23
- Route Guide 5-23
- Circuit Code 5-24
- Service Provider 5-24
- Carrier Based Routing 5-24
- Call Processing Flow 5-24
 - Trunk Termination 5-24
 - Subscriber Termination 5-25

CHAPTER 6

Command-Line Interface Routing 6-1

- Introduction 6-1
- Routing Types 6-1
 - Basic Subscriber Routing 6-2
 - Basic Trunk Routing 6-3
 - Carrier Based Routing 6-6
 - Basic Dial Plan Routing 6-8
 - Cluster Routing 6-10
 - Creating a Cluster Network with Three CMS/MGCs 6-10
 - Ported-In Sub from PSTN into CMS1 6-12
 - Adding One More CMS/MGC to a Cluster Network 6-12
- Call Types 6-15
 - 1+ InterLATA Call 6-15
 - 1+ IntraLATA Call 6-16
 - 0+ InterLATA Call 6-18
 - 0+ IntraLATA Call 6-20
 - Ported-In Call Processing 6-22
- Command-Line Interface Routing Examples 6-25
 - Carrier – Service-Provider 6-26
 - Carrier 9999 Use Dial-Plan “N” 6-26
 - Carrier All=N 6-26
 - Carrier All=Y 6-27
 - Carrier Intra=Y 6-28
 - Carrier Op-Serv=Y 6-28
 - Carrier Use Dial-Plan “Y” 6-29
 - Destination 6-29
 - Destination Carrier 6-29
 - Destination InterLATA 6-30
 - Destination RID 6-30
 - Destination ROUTE 6-30

Destination SUB	6-30
Dial-Plan	6-31
Dial-Plan Ca-Config	6-31
Dial-Plan “dp50”	6-32
DN2sub	6-32
Dp50 Digit-String=202	6-33
Ea-Use=Y	6-33
In DN2Sub	6-34
LNP Local Sub	6-34
LNP Route	6-35
LNP Trigger=Y	6-35
Not in DN2Sub	6-35
POP 50 Block	6-36
POP 50 No Block	6-36
POP Block-ea=N	6-36
POP Block-ea=Y	6-37
POP Ea-use=N	6-37
POP ITP=Y	6-37
POP LEC-OSS	6-38
Ported-Office-Code in CA	6-38
Ported-Office-Code in CA=N	6-38
Service Provider	6-38
Sub DP Dest InterLATA	6-39
Sub DP Dest IntraLATA	6-39
Subscriber Test1	6-40
Subscriber Test2	6-41
Subscriber and Sub-Profile	6-41
Trunk-grp 6969	6-42

CHAPTER 7**Preparing for Dial Plan Provisioning 7-1**

Introduction	7-1
Provisioning Prerequisites	7-1
Prerequisite Tasks	7-2
Prerequisite Information	7-2
Provisioning Tools	7-3
Command-Line Interface	7-3
Creating a Dial Plan	7-3
Add a Dial Plan Profile	7-4
Add a Dial Plan	7-4

Cisco BTS 10200 Provisioning Sequence 7-4

CHAPTER 8

Provisioning Dial Plans 8-1

Introduction 8-1

Provisioning a Dial Plan with the Command-Line Interface 8-1

Dial Plan 8-1

Dial Plan Profile 8-2

International Dial Plan 8-2

International Dial Plan Profile 8-2

Custom Dial Plan Profile 8-2

Custom Dial Plan 8-2

APPENDIX A

Call Types and Subtypes A-1

GLOSSARY



Preface

Revised: December 9, 2008, OL-15637-04

Introduction

This document provides detailed routing, translation, and dial plan information for the Cisco BTS 10200 Softswitch. It provides detailed digit manipulation, translation, and dial plan information for various routing scenarios. Additionally, this document provides dial plan configuration information.

Organization

This Cisco BTS 10200 Dial Plan Guide contains the following chapters:

- [Chapter 1, “Digit Translations”](#)—The Cisco BTS 10200 digit manipulation function enables manipulating either the digit string, or the nature of address (NOA), or both.
- [Chapter 2, “Routing”](#)—Provides a basic understanding of the Cisco BTS 10200 routing types and an explanation of all routing types and explanation of how they function.
- [Chapter 3, “Local Exchange Routing Guide”](#)—Provides a basic understanding of the Cisco BTS 10200 local exchange routing guide (LERG).
- [Chapter 4, “Electronic Number Mapping and Routing”](#)— Describes electronic number mapping (ENUM) and the ENUM routing capability.
- [Chapter 5, “Dial Plans and Routing”](#)—Provides detailed dial plan and routing information for the Cisco BTS 10200.
- [Chapter 6, “Command-Line Interface Routing”](#)—Provides a basic understanding of how the Cisco BTS 10200 Command Line Interface (CLI) functions with of the routing types and call types.
- [Chapter 7, “Preparing for Dial Plan Provisioning”](#)—Describes the prerequisite tasks that need to be performed before provisioning a dial plan.
- [Chapter 8, “Provisioning Dial Plans”](#)—Provides detailed instructions for configuring Cisco BTS 10200 configuration dial plans using the CLI.
- [Appendix A, “Call Types and Subtypes”](#)—Describes the valid call types implemented in the Cisco BTS 10200 Softswitch.

Obtaining Documentation and Submitting a Service Request

For information on obtaining documentation, submitting a service request, and gathering additional information, see the monthly *What's New in Cisco Product Documentation*, which also lists all new and revised Cisco technical documentation, at

<http://www.cisco.com/en/US/docs/general/whatsnew/whatsnew.html>

Subscribe to the *What's New in Cisco Product Documentation* as a Really Simple Syndication (RSS) feed and set content to be delivered directly to your desktop using a reader application. The RSS feeds are a free service and Cisco currently supports RSS Version 2.0.

Document Change History

The following table lists the revision history for the *Cisco BTS 10200 Softswitch Routing and Dial Plan Guide, Release 6.0.1*.

Version Number	Issue Date	Status	Reason for Change
OL-15637-01	31 Mar 2008	Initial	Initial document for Release 6.0.1
OL-15637-02	10 Apr 2008	Revised	Updated Route table information
OL-15637-03	31 Jul 2008	Revised	Updated trade mark block
OL-15637-04	9 Dec 2008	Revised	Added the “ International WZ1 (INTL_WZ1) Preferred Carrier Routing ” section on page 2-64 .



CHAPTER 1

Digit Translations

Revised: OL-15637-04, OL-15637-04

Introduction

The Cisco BTS 10200 Softswitch digit manipulation or digit translation function enables manipulating or translating the digit string, the nature of address (NOA), or both. Digit manipulation or translation can take place at several points in call processing, as illustrated in [Figure 1-1](#).

Figure 1-1 Digit Manipulation Locations and Stages

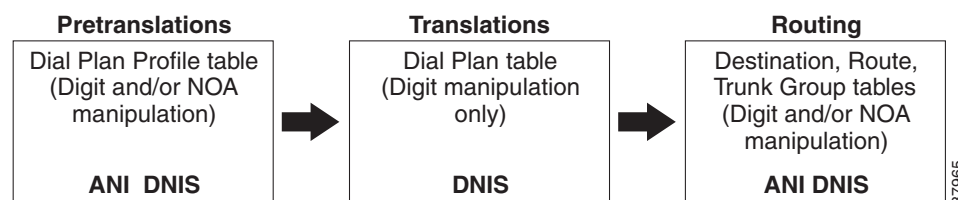

The digit and/or NOA manipulation rules can be applied during the pretranslations, translations, or routing stage. Additionally, digit manipulations or digit translations can occur at either the originating basic call system manager (OBCSM) or the terminating basic call system manager (TBCSM). The following sections describe the tables and tokens required for digit and/or NOA manipulation at each of these three stages. For details on routing and call processing including actions at specific points in call processing, refer to [Chapter 2, “Routing”](#) and to [Chapter 5, “Dial Plans and Routing.”](#)

Pre-Translations—In the pre-translations stage, the dial-plan-profile table is used to specify if automatic number identification (ANI), dialed number identification service (DNIS) or both are to be manipulated. The purpose of the pre-translation stage is to normalize the digits as required during the translations stage. For example: if a region supports 7-digit dialing, you can use DNIS manipulation in the dial-plan-profile to add a home numbering plan area (HNPA) to make it a 10-digit directory number (DN).

Translations—The dial-plan table can be used to manipulate the called party number (DNIS). Simple delete and prefix functionality is supported.

Routing—The routing is performed in the analyzed info point in call (PIC). The Destination table and/or Route table can be used to specify digit manipulation of the ANI, the DNIS or both. The out-pulsing number can be normalized by use of the destination table. In addition, if special manipulation is required based on the route selected, then special manipulation can be specified for each trunk group within a route.

If the Called Party Number terminates within the Cisco BTS 10200, and the subscriber number points to a trunk group, then digit manipulation rules for the ANI, the DNIS, or both can be specified in the Trunk Group table.

If the call is an interLATA call, or requires Carrier Routing, the ANI/DNIS digit manipulation identification (ID) specified in the Destination table is ignored and carrier based routing is performed.

Figure 1-2 illustrates the provisioning relationships for the Cisco BTS 10200 dial plans, which include the ANI/DNIS digital manipulation functions.

Figure 1-2 Dial Plan Provisioning Relationships

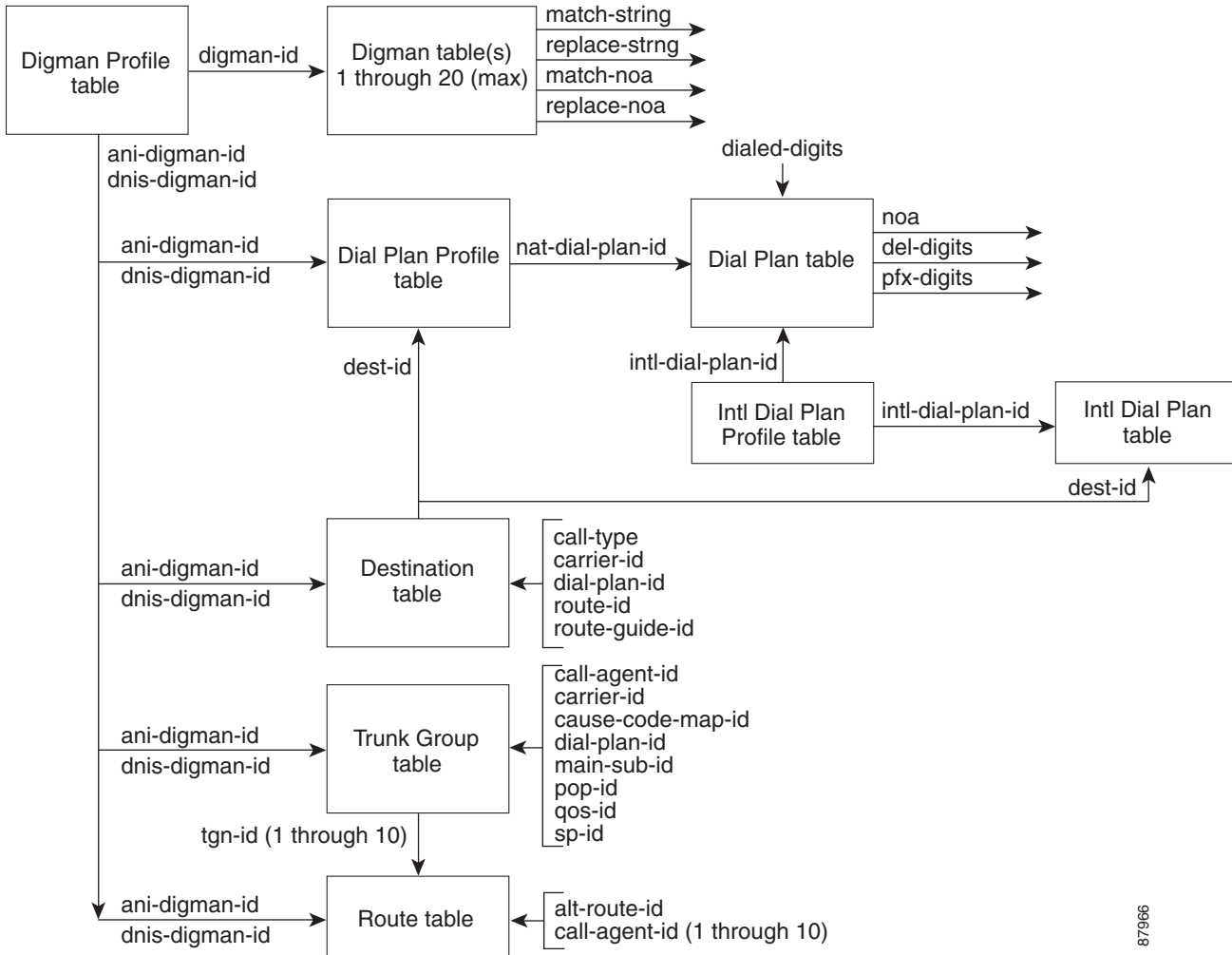

87966

Digit Manipulation

Digit manipulation or digit translation is performed based on as many as 20 different digit manipulation (digman) tables as designated by the digman-id and rule number, each of which can have a unique set of match-string and replace-string tokens and/or match-NOA and replace-NOA tokens.

The match-string is compared to the input-string. If a match is found, based on the rules specified here, then the replace-string replaces the matched string in all further call processing actions.

The match-string and replace-string tokens are constructed using the characters specified in [Table 1-1](#).

Table 1-1 *Digit Manipulation Rules Specifications*

Character(s)	Action
Digits 0 through 9, asterisk *, pound sign #	Digits found on a key-pad. Valid for use at any position in the input-string token, match-string token, and replace-string token.
Caret (^)	Beginning of String Character—Indicates a match to the beginning of the string. The caret character can only be the first character of the match-string. If the caret character is specified by itself, the input string is prefixed by the replace-string. For examples of caret character usage, refer to the “Caret (^) Character” section.
Dollar sign (\$)	End of String Character—The dollar sign character can be specified as only the last character of the match string. If the dollar sign character is specified by itself, the replace-string is appended to the input-string. The dollar sign character is used to specify the end of string. If digits at the end of the string are to be matched, the match-string is terminated by the “\$” character. For examples of dollar sign character usage, refer to “Dollar Sign (\$) Character” section.
Dot (.)	If the dot character is specified as a leading character, beginning of the string is assumed. If the dot character is specified as the last character, end of string is assumed. The dot character is used to identify the position of the match. The digits occupying the position specified by the dot character are skipped during the match operation. For examples of dot character usage, refer to “Dot (.) Character” section.
Question Mark (?)	The question mark character can appear anywhere, but multiple question marks have to be with another question mark. The question mark character cannot appear as a single character. If only one digit is to be manipulated, then the “?” mark should be preceded by ^ (caret) or followed by a “\$” (dollar) to signify the first digit or the last digit respectively. Used as a wildcard. Matches any one character. For examples of question mark character usage, refer to “Question Mark (?) Character” section. Note The “?” character by itself is treated as a request for help.
Percent sign (%)	Replace Character—The percent sign character can only be specified as the first character of the string. If specified by itself, the input string is replaced by the replace-string. Also used as a wildcard and when specified is used to match 0 or more characters preceding the digits specified in the match-string. For examples of percent sign character usage, refer to “Percent (%) Character (Match and Replace)” section.

Table 1-1 Digit Manipulation Rules Specifications (continued)

Character(s)	Action
Ampersand (&)	Prefix Character—The ampersand character can only be specified as the last character of the string. If specified by itself, it is used to indicate that no replace function is required on the matched string. The ampersand character is used to indicate if the input string matches with the match-string. If it is specified with digits preceding it, the specified digits are prefixed to the matched string. For examples of ampersand character usage, refer to “ Ampersand (&) Character ” section.
None (or none)	<p>Can only be specified by itself.</p> <p>The word “none” is used to specify null string. Can be used for both match-string and replace-string.</p> <p>Example 1:</p> <pre>match-string=none; replace-string=4692550000; indicates that when input string is null, replace it with 4692550000.</pre> <p>Example 2:</p> <pre>match-string=469255; replace-string=none; indicates that if a match is found, replace the matched string with null. If input string is 4692551234, after the digit manipulation, the resultant string will be 1234.</pre>

Match-string rules:

- Consist of digits 0-9, *, #, ^, \$, dot(.), question mark (?), percent (%) or word “none”.
- Caret (^) if specified, can only be first character of the string.
- Dollar Sign (\$) if specified, can only be the last character of the string.
- Percent (%) if specified, can only be first character of the string.
- Phrase “none” or “NONE” can only appear by itself.

The following rules are not enforced by the parser:

- Question Mark(s) (?) if specified, cannot appear in between a digit string (example: match-string=12??56; is invalid, but match-string=12????; is valid).
- Dots (.) if specified, can appear as leading dots; trailing dots; or both. (Examples: match-string=...555; match-string=555....; match-string=...555....;)

Replace-string rules:

- Consist of digits 0-9, *, #, ampersand (&) or word “none”.
- Ampersand (&) if specified, can appear by itself or be the last character of the string.
- Word “none” or “NONE” can only appear by itself.

Character Function

The following subsections provide information on the Cisco BTS 10200 character function.

Caret (^) Character

The caret (^) character is used to specify beginning of a string. The caret character is used when specific leading digits are to be deleted or replaced. The caret character is also used when digits are to be prefixed to the input string.

The following examples specify the use of the caret character:

Example 1

```
input-string=0119127210112; match-string=^011; replace-string=none. In this example, the
digit string 011 at the beginning of input string will be replaced with null. The
resultant output string=9127210112.
```

Example 2

```
input-string=9127210112; match-string=^; replace-string=011. In this example, since the
digit string 011 is prefixed to the input-string. The resultant
output-string=0119127210112.
```

Example 3

```
Enter 1 to continue translations 1
Enter input string 14692551234
Match string ^1
Replace string none
MATCHED
```

```
Output string=4692551234
```

Example 4

```
Enter 1 to continue translations 1
Enter input string 4692551234
Match string ^469255
Replace string 5
MATCHED
```

```
Output string=51234
```

Example 5

```
Enter 1 to continue translations 1
Enter input string 222
Match string ^
Replace string 1
MATCHED
```

```
Output string=1222
```

Dollar Sign (\$) Character

The dollar sign (\$) character is used to search from the end of string backwards instead of from the beginning of the string. The dollar sign character is also used when digits are to be appended to the end of the string, deleted or replaced from the end of the string.

If match-string=1234\$, the last 4 digits will be 1234.

If match-string=????\$, replace last 4 digits with the replace-string.

The following examples show the use of dollar sign character.

Example 1

input string=4692551234; match-string=????\$; replace-string=0000. In this example, digits 1234 will be replaced with 0000. The resultant output string=4692550000.

Example 2

input string=469255; match-string=\$; replace-string=0000. In this example, digits 0000 will be appended to the input-string. The resultant output string=4692550000.

Example 3

```
Enter 1 to continue translations 1
Enter input string 4692551234
Match string ?????$
Replace string none
MATCHED
```

Output string=469255

Example 4

```
Enter 1 to continue translations 1
Enter input string 4692551234
Match string ?????$
Replace string 0000
MATCHED
```

Output string=4692550000

Example 5

```
Enter 1 to continue translations 1
Enter input string 469255
Match string $
Replace string 0000
MATCHED
```

Output string=4692550000

Dot (.) Character

The dot (.) character is used to indicate string position at which match operation is to be performed. If a dot character is specified as the first character of the match-string, the digits specified by each dot character are skipped until a question mark or any digit is encountered.

The dot character can also be used to check the length of the input string (see examples below).

Example 1

match-string="...555" indicates that 555 appear in digit position 4-6. This will match on the following input string: 4695551234.

Example 2

"555..." Indicates that find a match on 555 where there are 4 more digits that follow 555. This will match any of the following input strings: 4695551234 or 5551234.

Example 3

```
Enter 1 to continue translations 1
Enter input string 4695551234
Match string ...555
Replace string &
MATCHED
```

```
Output string=4695551234
```

Example 4

```
Enter 1 to continue translations 1
Enter input string 4695551234
Match string ..... #CHECK IF INPUT STRING LENGTH=10
Replace string &
MATCHED
```

```
Output string=4695551234
```

Example 5

```
Enter 1 to continue translations 1
Enter input string 14695551234
Match string .....
Replace string &
Not MATCHED
```

```
Output string=14695551234
```

Example 6

```
Enter 1 to continue translations 1
Enter input string 222333
Match string ...33
Replace string none
MATCHED
```

```
Output string=2223
```

Example 7

```
Enter 1 to continue translations 1
Enter input string 22233
Match string ^...
Replace string none
Not MATCHED
```

```
Output string=22233
```

Question Mark (?) Character

The question mark (?) character is used to specify a wild card character based on its position in the match-string. Each question mark character represents one digit character.

If a question mark is specified as a leading character in a match-string, the beginning of input string is assumed. Match-string "??555" indicates that you should look for any three digits followed by digits 555. The question mark character can not be specified as the only character as it conflicts with the use of "?" as a help character. So, if the first digit is to be matched, use ^? to represent first digit and ?\$ to represent the last digit of a digit-string.

The following examples show the use of question mark (?) character.

Example 1

"???555" indicates that 555 appear in digit position 4-6. This will match the following input string: 4695551234.

Example 2

"555????" Indicates that find a match on 555 where there are 4 more digits that follow 555. This will match any of the following input strings: 4695551234 or 5551234. Digits 5551234 will be replaced with the replace string.

Example 3

"^?" indicates to match on the 1st digit

Example 4

"?\$" indicates to match on the last digit

Example 5

```
Enter 1 to continue translations 1
Enter input string 14692551234
Match string ^1???
Replace string none
MATCHED
```

Output string=2551234

Example 6

```
Enter 1 to continue translations 1
Enter input string 4692551234
Match string ????$
Replace string none
MATCHED
```

Output string=469255

Example 7

```
Enter 1 to continue translations 1
Enter input string 4695551234
Match string ??555
Replace string 5
MATCHED
```

Output string=51234

Example 8

```
Enter 1 to continue translations 1
Enter input string 4692551234
Match string ??555
Replace string none
Not MATCHED
```

Output string=4692551234

Percent (%) Character (Match and Replace)

The percent character (%) is used to specify the match and replace function. That is, if a match occurs, replace the matched string with the replace-string. The percent character is also used as a wild card character.

If `match-string=%`, the whole input-string is replaced by the replace-string.

If `match-string=%nn`, the input-string is searched from the beginning until it matches pattern `nn`, and the whole string from the beginning to the end of pattern is replaced with the replace-string.

If `match-string=%...nnn`, the input-string is searched for pattern `nnn` in digit positions 4, 5, and 6. If a match occurs, the digit string from the beginning including the pattern `nnn` is replaced with the replace-string.

The following examples show the use of the percent (%) character.

Example 1

`%555` - indicates match on 555 and any number of digits preceding it. This will match on of the following input string: 4695551234. Digits 469555 will be replaced with the replace string.

Example 2

`%` - indicates match on any number of digits.

Example 3

```
Enter 1 to continue translations 1
Enter input string 4692551234
Match string %
Replace string 55555
MATCHED
```

Output string=55555

Example 4

```
Enter 1 to continue translations 1
Enter input string 4692551234
Match string %255
Replace string 5
MATCHED
```

Output string=51234

Example 5

```
Enter 1 to continue translations 1
Enter input string 4692551234
Match string %...255MATCH DIGITS 255 IN DIGIT POSITIONS 4,5,6
Replace string 5
MATCHED
```

Output string=51234

Example 6

```
Enter 1 to continue translations 1
Enter input string 4692551234
Match string %...255?MATCH DIGITS 255 IN DIGIT POSITIONS 4,5,6 AND 1 MORE DIGIT
Replace string 55
MATCHED
```

Output string=55234

Ampersand (&) Character

The ampersand character (&) is used in the replace-string to leave the matched string as is without replacing it with the replace string. If ampersand is specified by itself, the digit manipulation leaves the input string as is. If a digit string is specified followed by an ampersand, the digit string is prefixed to the matched string.

The following examples show the use of the ampersand (&) character.

Example 1

```
input-string=4695551212; match-string=555.; replace-string=&; will return an indication of
match, but the output string will be unaffected.
```

Example 2

```
input string=4695551234; match-string=???555.; replace-string=1&; In this example, if the
input string is 10 digits long, and digits(4-6) 555, prefix the input string with 1. The
resultant output string=14695551234.
```

Example 3

```
Enter 1 to continue translations 1
Enter input string 4692551234
Match string ???255
Replace string 1&
MATCHED
```

```
Output string=14692551234
```

Example 4

```
Enter 1 to continue translations 1
Enter input string 14692551234
Match string ^1.....
Replace string &
MATCHED
```

```
Output string=14692551234
```

Example 5

```
Enter input string 4695551212
Match string ^...555....
Replace string &
MATCHED
```

```
Output string=4695551212
```

Example 6

```
Enter 1 to continue translations 1
Enter input string *85#
Match string *
Replace string &
MATCHED
```

```
Output string=*85#
```

Example 7

```

Enter 1 to continue translations 1
Enter input string *85#
Match string #
Replace string &
MATCHED

Output string=*85#

```

Delete Digits Function

The Cisco BTS 10200 digit manipulation function supports the following delete capabilities:

- Deletion of leading digits
- Deletion of specific leading digits
- Deletion of trailing digits
- Deletion of specific trailing digits
- Deletion of leading digits only if the length matches
- Deletion of trailing digits only if the length matches

Deletion of Leading Digits

The Cisco BTS 10200 digit manipulation functions supports the deletion of leading digits, as indicated in the following example:

```

Add digman id=del3; match-string=???; replace-string=none; or
Add digman id=del3; match-string=^???; replace-string=none;
*****
Enter input string 4692551234
Match string ???
Replace string none
MATCHED

Output string=2551234
*****

```

Deletion of Specific Leading Digits

The Cisco BTS 10200 digit manipulation function supports the deletion of specific leading digits, as indicated in the following example:

```

Add digman id=del00; match-string=^00; replace-string=none;
*****
Enter input string 0012345
Match string ^00
Replace string none
MATCHED

Output string=12345
*****

```

Deletion of Trailing Digits

The Cisco BTS 10200 digit manipulation function supports the deletion of trailing digits, as indicated in the following example:

```
Add digman id=dellast4; match-string=????$; replace-string=none;
*****
Enter input string 4692551234
Match string ?????$
Replace string none
MATCHED

Output string=469255
*****
```

Deletion of Specific Trailing Digits

The Cisco BTS 10200 digit manipulation function supports deletion of specific trailing digits, as indicated in the following example:

```
Add digman id=delx1212; match-string=1212$; replace-string=none;
*****
Enter input string 4695551212
Match string 1212$
Replace string none
MATCHED

Output string=469555
*****
```

Deletion of Leading Digits Only If the Length Matches

The Cisco BTS 10200 digit manipulation function supports the deletion of leading digits only if the length of input-string matches the length implied by the match-string, as indicated in the following example:

```
Add digman id=del310; match-string=^???.....; replace-string=none; or
Add digman id=del310; match-string=???.....; replace-string=none;
*****
Enter input string 4692551234
Match string ???.....
Replace string none
MATCHED

Output string=2551234
*****
```

Deletion of Trailing Digits Only If the Length Matches

The Cisco BTS 10200 digit manipulation function supports deletion of trailing digits only if the length of input-string matches the length implied by the match-string, as indicated in the following example:

```
Add digman id=dellast4; match-string=.....????; replace-string=none; or
Add digman id=del310; match-string=^.....????$; replace-string=none;
*****
Enter input string 4692551234
Match string .....????
Replace string none
MATCHED

Output string=469255
*****
```

Prefix Digits Function

The Cisco BTS 10200 digit manipulation function supports the prefix of digits. The following prefix functions are supported:

- Prefix leading digits
- Prefixing of digits only if length matches

Prefix Leading Digits

The Cisco BTS 10200 digit manipulation function supports the prefixing of leading digits, as indicated in the following example:

```
Add digman id=px469; match-string=^; replace-string=469;
*****
Enter input string 5551234
Match string ^
Replace string 469
MATCHED

Output string=4695551234
*****
```

Prefixing of Digits Only If Length Matches

The Cisco BTS 10200 digit manipulation function supports the prefixing of digits only if length matches, as indicated in the following example:

```
Add digman id=px469if7; match-string=^.....; replace-string=469; or
Add digman id=px469if7; match-string=.....; replace-string=469;
*****
Enter input string 5551234
Match string ^.....
Replace string 469
MATCHED

Output string=4695551234
*****
```

Replace (Delete and Prefix) Digits Function

The Cisco BTS 10200 digit manipulation function supports the digit replacement based on matched string; that is, the matched string will be replaced with the replace-string.

- Replacement of leading digits
- Replacement of trailing digits
- Replacement of specific digits
- Replacement of leading digits only if length matches
- Replacement of specific digits in a specific digit position
- Replacement of digits in a specific digit position
- Replacement of digits only if null
- Replacement of any input string

Replacement of Leading Digits

The Cisco BTS 10200 digit manipulation function supports the replacement (delete and prefix) of leading digits, as indicated in the following examples:

```
Add digman id=del6pfx5; match-string=?????; replace-string=5; or
Add digman id=del6pfx5; match-string=^?????; replace-string=5;
*****
Enter input string 4692551234
Match string ??????
Replace string 5
MATCHED

Output string=51234
*****
Enter input string 4692551234
Match string ^?????
Replace string 5
MATCHED

Output string=51234
*****
```

Replacement of Trailing Digits

The Cisco BTS 10200 digit manipulation function supports the replacing trailing digits, as indicated in the following example:

```
Add digman id=del4rep0000; match-string=????$; replace-string=0000;
*****
Enter input string 4692551234
Match string ????$
Replace string 0000
MATCHED

Output string=4692550000
*****
```

Replacement of Specific Digits

The Cisco BTS 10200 digit manipulation function supports specific digits replacement only if the input string matches specific digits, as indicated in the following example:

```
Add digman id=del469255pfx5; match-string=469255; replace-string=5;
*****
Enter input string 4692551234
Match string 469255
Replace string 5
MATCHED

Output string=51234
*****
```

Replacement of Leading Digits Only If Length Matches

The Cisco BTS 10200 digit manipulation function supports leading digits replacement only if the length matches, as indicated in the following examples:

```
Add digman id=del6pfx5; match-string=469255...; replace-string=5;
*****
Enter input string 4692551234
Match string 469255...
Replace string 5
MATCHED

Output string=51234
*****
Enter input string 4692550
Match string 469255...
Replace string 5
Not MATCHED

Output string=4692550
*****
```

Replacement of Specific Digits In a Specific Digit Position

The Cisco BTS 10200 digit manipulation function supports specific digits replacement specified by position, as indicated in the following example:

```
Add digman id=rep555; match-string=...555...; replace-string=222;
*****
Enter input string 4695551234
Match string ...555...
Replace string 222
MATCHED

Output string=4692221234
*****
```

Replacement of Digits In a Specific Digit Position

The Cisco BTS 10200 digit manipulation function supports the digits replacement in the specific digit position, as indicated in the following examples:

```
Add digman id=rep456w222; match-string=...???...; replace-string=222;
Add digman id=replast4; match-string=.....????; replace-string=0000;
*****
Enter input string 4695551234
Match string ...???...
Replace string 222
MATCHED

Output string=4692221234
*****
Enter input string 4695551234
Match string .....????
Replace string 0000
MATCHED

Output string=4695550000
*****
```

Replacement of Digits Only If Null

The Cisco BTS 10200 digit manipulation function supports digit replacement if input digit string is null, as indicated in the following examples:

```
Add digman id=repifnull; match-string=none; replace-string=4692550000;
*****
Enter input string none
Match string none
Replace string 4692550000
MATCHED

Output string=4692550000
*****
Enter input string 4695551234
Match string none
Replace string 4692550000
Not MATCHED

Output string=4695551234
*****
```

Replacement of Any Input String

The Cisco BTS 10200 digit manipulation function supports the replacement of any input string with the replace-string, as indicated in the following examples:

```
Add digman id=replace; match-string=%; replace-string=4692550000;  
*****
```

```
Enter input string none  
Match string %  
Replace string 4692550000  
MATCHED
```

```
Output string=4692550000  
*****
```

```
Enter input string 4695551234  
Match string %  
Replace string 4692550000  
MATCHED
```

```
Output string=4692550000  
*****
```

Nature of Address Manipulation

The Cisco BTS 10200 Digit Manipulation table also supports NOA manipulation.

To manipulate the NOA, the match-string and the replace-string should be null.

```
Add digman id=dg1; rule=1; match-noa=any; replace-noa=subscriber;
```

If both digit and NOA manipulation rules are defined, the digit manipulation is only performed if the NOA value specified in the match-noa matches the input NOA and the match-string matches the input string.

```
Add digman id=dg1; rule=1; match-string=%255; replace-string=5; match-noa=national;
replace-noa=abbr;
```

Table 1-2 Nature Of Address Table

NOA	Description
950	NOA used to specify 950 call.
ANY	When specified matches any of the other NOAs. This NOA can only be specified in the MATCH-NOA field.
ABBR	NOA used to specify abbreviated number.
CUT-THRU	NOA used to specify no number present, cut-thru call.
INTL	NOA used to specify international number
INTL-OPR	NOA used to specify international number, operator requested (valid for called party number only).
INTL	NOA used to specify unique international number.
NATIONAL	NOA used to specify national number.
NAT-OPR	NOA used to specify national number, operator requested (valid for called party number only).
NETWORK	NOA used to specify network.
NON-UNIQUE-INTL	NOA used to specify non-unique international number (valid for calling party number).
NON-UNIQUE-NATIONAL	NOA used to specify non-unique national number (valid for calling party number).
NON-UNIQUE-SUBSCRIBER	NOA used to specify non-unique subscriber number (valid for calling party number).
NS0	NOA used to specify network specific (111 1000) number.
NS1	NOA used to specify network specific (111 1001) number.
NS2	NOA used to specify network specific (111 1010) number.
NS3	NOA used to specify network specific (111 1011) number.
NS4	NOA used to specify network specific (111 1100) number.
NS5	NOA used to specify network specific (111 1101) number.
NS6	NOA used to specify network specific (111 1110) number.
OPERATOR	NOA used to specify an operator call.
PORTED-NUMBER-WITHOUT-RN	The ported number may be prefixed with the network ID, or may not be prefixed with anything (DN or NTKW-ID+DN), but does not include the switch ID.
PORTED-NUMBER-WITH-RN	The ported Number is prefixed with the network ID and switch ID (RN+DN).

Table 1-2 Nature Of Address Table (continued)

NOA	Description
PRIVATE	NOA used to specify private numbering plan.
RESERVED	Reserved NOA.
SPARE0/SPARE2	Spare. Not used.
SUB-OPR	NOA used to specify subscriber number, operator requested (valid for called party number only).
SUBSCRIBER	NOA used to specify subscriber number.
TEST-LINE	NOA used to specify test line number.
UNKNOWN	NOA is unknown.
VSC	NOA used to specify vertical service code.

Nature of Address Route Profile

The Nature of Address (NOA) Route Profile (noa-route-profile) table is used to support NOA-based routing on the Cisco BTS 10200. This profile defines the NOA route ID. The ID can be assigned to a single Dial Plan Profile table or multiple Dial Plan Profile tables. For token names and description details for the NOA Route Profile table, refer to the [Cisco BTS 10200 Softswitch CLI Database](#).

Nature of Address Route

The Nature of Address (NOA) Route (noa-route) table defines NOA-based routing on the Cisco BTS 10200. When the NOA-based routing is specified in the Dial Plan Profile table, the Cisco BTS 10200 uses the received called NOA to index the NOA Route table and determine the destination ID for further routing. The destination ID can point to a specific route based on the NOA or it can point to a dial plan. When a destination ID points to a dial plan, the received called party number is translated by use of the dial plan. For token names and description details for the NOA Route table, refer to the [Cisco BTS 10200 Softswitch CLI Database](#).

ANI or DNI Service Manipulation

The Cisco BTS 10200 supports DNIS or ANI digit manipulation, it includes digit manipulation or nature of address manipulation or both. When ANI manipulation is defined, it usually refers to the calling party number (CPN) which is normally displayed when a call is terminated to a device with the calling number delivery (CND) feature.

In countries like China, there are additional requirements regarding ANI display. The requirements are to display ANI in the dialable format. The term *dialable* means the user can simply call up the display and hit the dial button to place the call based on the received ANI. This requires ANI to contain an area code or national destination code (NDC) for a long distance call while only displaying subscriber number for a local call. The rules defined above can be used to manipulate ANI digits to the desired format.

When call forwarding has occurred, the ANI manipulation is performed as follows:

- If redirecting party number is available, the redirecting party number is manipulated.
- If redirecting party number is not available, but original called number (OCN) is available, the OCN is manipulated.
- If neither redirecting party number nor OCN is available, the calling party number is manipulated.

The following sections describe the provisioning and actions in each of the three stages in greater detail.

Pretranslation Stage

In the pretranslation stage, the dial-plan-profile table is used to specify if ANI, DNIS, or both are to be manipulated. The purpose of the pre-translation stage is to normalize the digits, as required, during the translation stage.

In addition to manipulation of the ANI/DNIS digits, the pretranslation stage can also be used to determine the NOA of the incoming digits (either ANI or DNIS or both).

The Dial Plan Profile table has been modified to allow provisioning of the ANI and DNIS digit manipulation rules.

Example 1

In the first example, since the first character of the input string matches the specified match-string (^*), the NOA is changed to a vertical service code (VSC).

```
Add digman id=pretrans; rule=1; match-string=^*; replace-string=&; match-noa=any;
replace-noa=vsc;
```

```
Enter input string *55#
Match string ^*
Replace string &
MATCHED
```

```
Output string=*55#
```

Example 2

In the second example, since the last character of the input string matches the specified match-string (#), the NOA is changed to a VSC.

```
Add digman id=pretrans; rule=2; match-string=#; replace-string=&; match-noa=any;
replace-noa=vsc;
```

```
Enter input string *55#
Match string #
Replace string &
MATCHED
```

```
Output string=*55#
```

Example 3

In the third example there is no match, so the NOA is not changed and the output-string is the same as the input-string.

```
Add digman id=pretrans; rule=3; match-string=*; replace-string=&; match-noa=any;
replace-noa=vsc;
```

```
Enter input string 5555
Match string *
Replace string &
Not MATCHED
```

```
Output string=5555
```

Determining NOA for China

The following table can be used to determine the NOA of incoming calls for China.

Table 1-3 NOA Determination for China

Rule No.	Match-String	Replace String	Match-NOA	Replace NOA	Remarks
1	*	&	Any	VSC	If first digit is a *, treat it as a VSC code.
2	#	&	Any	VSC	If first digit is a #, treat it as a VSC code.

Digit Manipulation Profile

The Digit Manipulation Profile (digman-profile) table is used to create unique IDs for digit manipulation. This ID must be created before the Digit Manipulation table can be provisioned. For token names and description details for the Digit Manipulation Profile table, refer to the [Cisco BTS 10200 Softswitch CLI Database](#).

Digit Manipulation

The Digit Manipulation (digman) table is used to perform digit and nature of address (NOA) manipulation. For token names and description details for the Digit Manipulation table, refer to the [Cisco BTS 10200 Softswitch CLI Database](#).

Dial Plan Profile

The Dial Plan Profile (dial-plan-profile) table creates dial-plan-profile ids before they are assigned to subscribers or trunk groups. The dial-plan-profile ID links digit-string entries in the Dial Plan table within a dial plan. Different dial-plan-profile ids are assigned to subscribers and trunk groups. A dial-plan-id must be created in this table before entries can be added to the Dial Plan table. For token names and description details for the Dial Plan Profile table, refer to the [Cisco BTS 10200 Softswitch CLI Database](#).

International Dial Plan Profile

The International Dial Plan Profile (intl-dial-plan-profile) table is used to create unique IDs for international dial plans. This ID must be created before provisioning the International Dial Plan table. For token names and description details for the International Dial Plan Profile table, refer to the [Cisco BTS 10200 Softswitch CLI Database](#).

Translations Stage

The Dial-Plan table or International Dial-Plan table is used during the Translations stage to manipulate only the called party number. The previously existing capability of a simple delete and/or prefix digit manipulation function is supported.

**Note**

Although the simple delete and/or prefix digit manipulation function is still supported, it is no longer necessary, because the same function(s) can now be accomplished in the other two stages.

Dial Plan

Dial plans analyze, screen, and route calls based on dialed digits. The Dial Plan (dial-plan) table holds dial plan information for a specific type of call. It defines valid dialing patterns and determines call routing. All records that share a common dial-plan-profile ID are considered a dial plan. For token names and description details for the Dial Plan table, refer to the [Cisco BTS 10200 Softswitch CLI Database](#).

International Dial Plan

The International Dial Plan (intl-dial-plan) table holds international dial plan information for calls to regions outside the North American Numbering Plan (NANP). It contains the country code, minimum and maximum digits, the country name, and the route-grp-id. For token names and description details for the International Dial Plan table, refer to the [Cisco BTS 10200 Softswitch CLI Database](#).

Variable Digit Dialing

Variable digit dialing is used in the Europe where the length of the dialed number can vary from seven digits to ten digits, mainly in Germany. For a given NDC or EC, the DN can vary from the minimum to the maximum specified in the Exchange Code table.

Example:

ndc=349, ec=234; min-digits=7; max-digits=10; (from the Exchange Code table)

DN=3492340 could be a DN

DN=3492341234 could also be a DN belonging to ndc=349, ec=234

DN=349234222 could also be a 9 digit DN

Variable Digit Dialing Provisioning

To provision variable digit dialing according to the example given in the [“Variable Digit Dialing”](#) section, take the following steps:

-
- | | |
|---------------|---|
| Step 1 | add exchange-code ndc=349, ec=234; min-digits=7; max-digits=10; |
| Step 2 | add office-code ndc=349; ec=234; dn-group=0; (For the DN=3492340) |
| Step 3 | add office-code ndc=349; ec=234; dn-group=1xxx; dn-length= 10; (For the 10 digit DNs) |
| Step 4 | add office-code ndc=349; ec=234; dn-group=2xx; (For the 9 digit DNs in the dn group) |
| Step 5 | add office-code ndc=349; ec=234; dn-group=12x; (For the 9 digit DNs) |
-

Routing Stage

The digit manipulations for an outgoing call can be performed using one of the following tables:

- Destination table
- Route table
- Trunk Group table for subscriber termination

The ANI/DNIS digit manipulation specified in the Destination table is applied during the outgoing call setup. The out-pulsing number can also be normalized using the destination table. In addition, if special digit manipulation is required based on the route selected, it can be specified for each trunk group within a route.

If the called number terminates within the Cisco BTS 10200, and the subscriber number points to a trunk group, then digit manipulation rules for ANI, DNIS, or both can be specified in the Trunk Group table.

If the call is an interLATA call or requires Carrier routing (ROUTE-TYPE=CARRIER), the ANI/DNIS digit manipulation IDs specified in the destination table are ignored and carrier-based routing is performed.

**Note**

Although both **pfx_digits** and **del_digits** still work in the Cisco BTS 10200 dial plan table, if the subscriber dials a 7-digit number, but local number portability (LNP) queries require a 10-digit DN, then the digman tables should be set up to add an NPA, making the called number a 10-digit DN before an LNP query is performed.

Destination

The Destination (destination) table defines the call type and the routing information for the dialed digits. Multiple digit strings in the Dial Plan table can use the same destination ID. For token names and description details for the Destination table, refer to the [Cisco BTS 10200 Softswitch CLI Database](#).

For additional information on call types, refer to [Appendix A, “Call Types and Subtypes.”](#)

Route

The Route (route) table contains a list of up to ten trunk groups for call routing. If all the trunk groups are busy or not available, call processing uses the alt-route-id (if specified) to route the call. The Element Management System (EMS) provisions the Call Agent ID field based on the Trunk Group table. For token names and description details for the Route table, refer to the [Cisco BTS 10200 Softswitch CLI Database](#).

**Note**

The Route table enables the service provider to provision a list of up to 10 trunk groups (TG1 to TG10), and a parameter for selecting the priority of the TGs for routing (TG-SELECTION). The system attempts to route the call on the highest priority TG. If the call cannot be completed on the highest priority TG, the system attempts to use the next (lower priority) TG, a process known as route advance. The system attempts route advance to lower priority TGs up to three times. (Any TG in the list that is administratively out of service is not counted as an attempt.) If all three attempts fail, the call is released, and the system provides a release announcement.

Trunk Group

The Trunk Group (trunk-grp) table identifies the trunk group and maps it to the associated media gateway.

The Cisco BTS 10200 supports the following trunk group types: announcement, CAS, ISDN, SS7 and SOFTSW. The Trunk Group table defines common information based on the trunk group type. The Cisco BTS 10200 supports announcement, CAS, ISDN, SS7 and SOFTSW trunk group profiles. For token names and description details for the Trunk Group table, refer to the [Cisco BTS 10200 Softswitch CLI Database](#).

Policy NXX

The Policy NXX (policy-nxx) table is used when a number services call results in a translated number, carrier ID, translated number and a carrier ID, or a route ID. For token names and description details for the Policy NXX table, refer to the [Cisco BTS 10200 Softswitch CLI Database](#).

**Note**

The original call type is preserved in billing when the routing number is changed by the use of the Policy NXX table.

Call Type Profile

The Call Type Profile (call-type-profile) table defines the call type properties supported by the Cisco BTS 10200. Provision this table if the ALL-CALL-QUERY flag in the LNP-PROFILE table is set to Y and the ACQ-LNP-QUERY token in the Destination table is set to ACQ-BASED-ON-CALL-TYPE. For token names and description details for the Call Type Profile table, refer to the [Cisco BTS 10200 Softswitch CLI Database](#).

For additional information on call types, refer to [Appendix A, “Call Types and Subtypes.”](#)

Sample Provisioning

Figure 1-3 provides a sample provisioning script for the implementation of the digman functionality.

Figure 1-3 Sample Provisioning

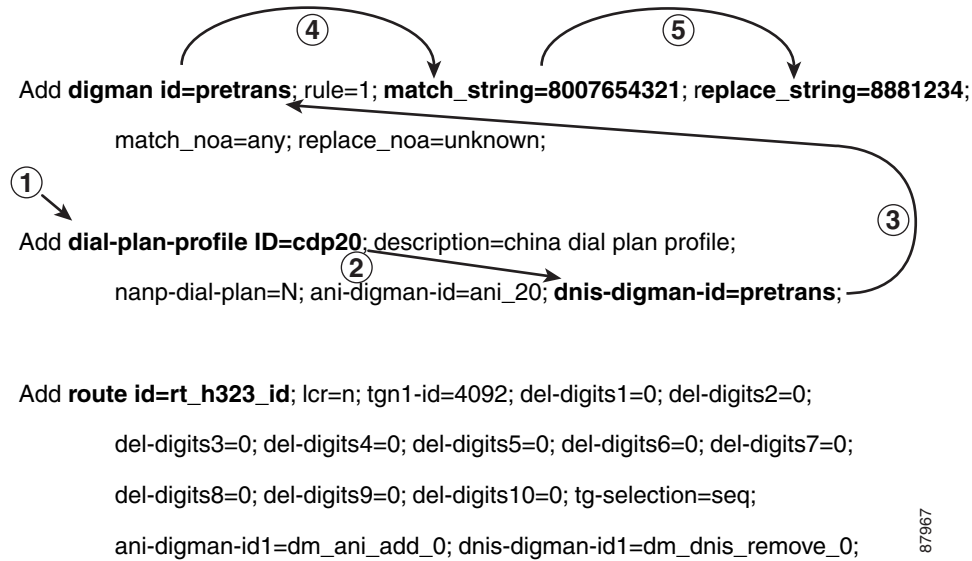

87967

Caller A, using dial-plan-id=cdp20, dials 8007654321. The call hits the dial-plan-profile table (1) and uses the pretranslation entry (2 and 3). It matches on the 800 number (4) and replaces it with 8881234 (5).

Feature Interaction

When a call is terminated to a subscriber with Call Forwarding activated, a feature interaction occurs when calls are forwarded out of the Cisco BTS 10200. In China, the Cisco BTS 10200 uses H.323 signaling to route calls to the PSTN; however, this scenario applies to any call which is forwarded over a non-SS7 signaling interface.

The H.323 protocol and other non-SS7 signaling protocols do not support the Charge Number parameter, Original Called Party Number, or Redirecting Party Number. When call forwarding occurs, the ANI manipulation is performed on the redirecting party number if it is available. The DN of the forwarding party should also be sent as ANI digits and, as such in a forwarding scenario, the called number of the forwarding party should also be manipulated for the call.



CHAPTER 2

Routing

Revised: December 9, 2008, OL-15637-04

Introduction

This chapter provides a basic understanding of the Cisco BTS 10200 Softswitch routing types and an explanation of all routing types and how they function. Additionally examples of the routing types are provided. This chapter is divided into the following sections:

- [Routing Types](#)
- [Call Types](#)
- [Policy-Based Flexible Routing](#)

Routing Types

Call routing requires some basic information. That information is obtained from either the subscriber table or the trunk group table. The information gathered from the subscriber table or the trunk group table provides the starting point for routing a call. Additional information must be gathered from the dial-plan profile table and dial-plan identification (ID) tables. These are the main tables which determine call routing and are instrumental in determining other information needed to route a call, such as call type and destination.

This section provides the Cisco BTS 10200 routing type information. The following topics are covered in this section:

- **Basic Subscriber Routing**—This is the Cisco BTS 10200 routing type which is based on subscriber needs, Basic Subscriber Routing can be used for both line and trunk routing.
- **Basic Trunk Routing**—This is the Cisco BTS 10200 routing type which is used for basic trunk routing. Basic Trunk Routing can only be used for trunk routing.
- **Service Provider Routing**—This is the Cisco BTS 10200 routing type which is used in the wholesale network environment where the network operator owns the facility and provides transport facilities to carry voice calls on behalf of smaller service providers. Service Provider Routing can only be used for trunk routing.
- **Carrier Based Routing**—This is the Cisco BTS 10200 routing type which is based on specific carrier needs. Carrier Based Routing can be utilized for both line and trunk routing.
- **Basic Dial Plan Routing**—This is the Cisco BTS 10200 default routing type. Basic Dial Plan Routing can be utilized for both line and trunk routing.
- **ANI Based Routing**—This is the Cisco BTS 10200 routing type based on automatic number identification (ANI) as the call information comes in on a trunk on a hosted private branch exchange (PBX) configuration. ANI Based Routing can only be utilized for trunk routing.
- **NOA Routing (ITU Local Number Portability)**—Nature of address (NOA) routing is used to select separate dial plans for directory number (DN) and routing number (RN). The ISDN user part (ISUP) initial address message (IAM) called party number (CdPN) parameter contains a NOA value. The NOA value distinguishes the format of the digits, that is, DN only vs. RN+DN. In some countries, DN prefixes can be the same as some RNs. In these cases, NOA routing allows the use of different dial plans for DN routing and RN routing.
- **Cluster Routing**—A cluster is defined as two or more Cable Management Servers (CMSs) along with Media Gateway Controllers (MGCs) (or combined CMS/MGCs) deployed within a network. The cluster appears as one logical CMS/MGC looking towards the public switched telephony network (PSTN).
- **On-Net Routing and LNP for Inter-CMS Routing**—On-Net Routing and LNP for Inter-CMS routing provides ANSI LNP query support for carrier calls, LNP query for on-net routing (inter-CMS routing), on-net route bypass of carrier route, removal of LNP query result data when Carrier LNP-QUERY=N, and ignore inbound LNP information.
- **International WZ1 (INTL_WZ1) Preferred Carrier Routing**—Enhances the flexibility of preferred carrier routing for INTL_WZ1 calls.

Basic Subscriber Routing



Note When a customer is temporarily disconnected, all calls except 911 calls are routed to the customer support number.

This section describes the Cisco BTS 10200 basic subscriber routing. Refer to [Figure 2-1](#) and review the following summary of subscriber routing flow.

- Step 1** Subscriber incoming received or placed.
 - Step 2** Get the subscriber table (sub-profile ID).
 - Step 3** Get the subscriber-profile table (dial-plan identification (DP-ID)).
 - Step 4** Go to the dial-plan (based on DP-ID).
 - Step 5** Go to destination table and get the call type and destination.
 - Step 6** Determine the call type. If the call type is toll free, 900, or 500, proceed to Step 7. If the call type is casual, proceed to Step 8. If the call type is via a presubscribed interexchange carrier (PIC), proceed to Step 9.
 - Step 7** If the call type is toll free, 900, or 500, the Cisco BTS 10200 uses the dial plan to select the call route and to route the call.
 - Step 8** If the call type is casual, the Cisco BTS 10200 uses the carrier routing information to select the call route and to route the call.
 - Step 9** If the call type is via a PIC, the Cisco BTS 10200 uses the PIC carrier routing information to select the call route and to route the call.
-

Figure 2-1 Basic Subscriber Routing

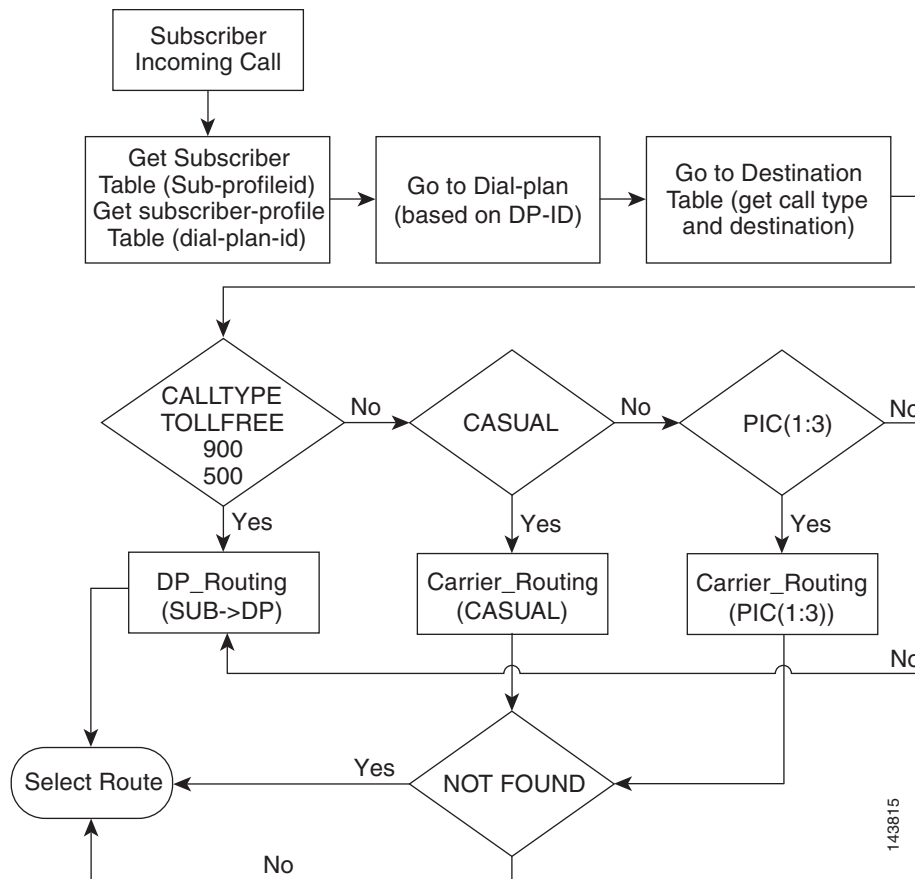

Basic Trunk Routing

This section describes the Cisco BTS 10200 basic trunk routing. Refer to [Figure 2-2](#) and review the following summary of basic trunk routing flow.

-
- Step 1** Trunk group (TG) call received or placed.
 - Step 2** Get the DP-ID from the TG.
 - Step 3** Go to the dial-plan and get the destination based on the digits and DP-ID.
 - Step 4** Go to the destination table and get the call type and the route.
 - Step 5** Determine the call type. If the call type is toll free, 900, or 500, proceed to Step 6. If the call type is local traffic, proceed to Step 7. If the call type is casual service provider (SP), proceed to Step 8. If the call type is transit network selection (TNS), proceed to Step 9. If the call type is TG carrier, proceed to Step 10. If the call type is TG SP, proceed to Step 11.
 - Step 6** If the call type is toll free, 900, or 500, the Cisco BTS 10200 uses the dial plan to select the call route and to route the call.
 - Step 7** If the call type is local traffic, the Cisco BTS 10200 uses the dial plan to select the call route and to route the call.

- Step 8** If the call type is casual SP, the Cisco BTS 10200 uses the SP routing to select the call route and to route the call. If the SP routing is not found, the Cisco BTS 10200 uses the dial plan to select the call route and to route the call.
- Step 9** If the call type is TNS, the Cisco BTS 10200 uses the carrier routing to select the call route and to select the call route and to route the call. If the carrier routing is not found, the Cisco BTS 10200 uses the dial plan to select the call route and to route the call.
- Step 10** If the call type is TG carrier, the Cisco BTS 10200 uses the carrier routing to select the call route and to route the call. If the carrier routing is not found, the Cisco BTS 10200 uses the dial plan to select the call route and to route the call.
- Step 11** If the call type is TG SP, the Cisco BTS 10200 uses the SP routing to select the call route and to route the call. If the SP routing is not found, the Cisco BTS 10200 uses the dial plan to select the call route and to route the call.
-

Figure 2-2 Basic Trunk Routing

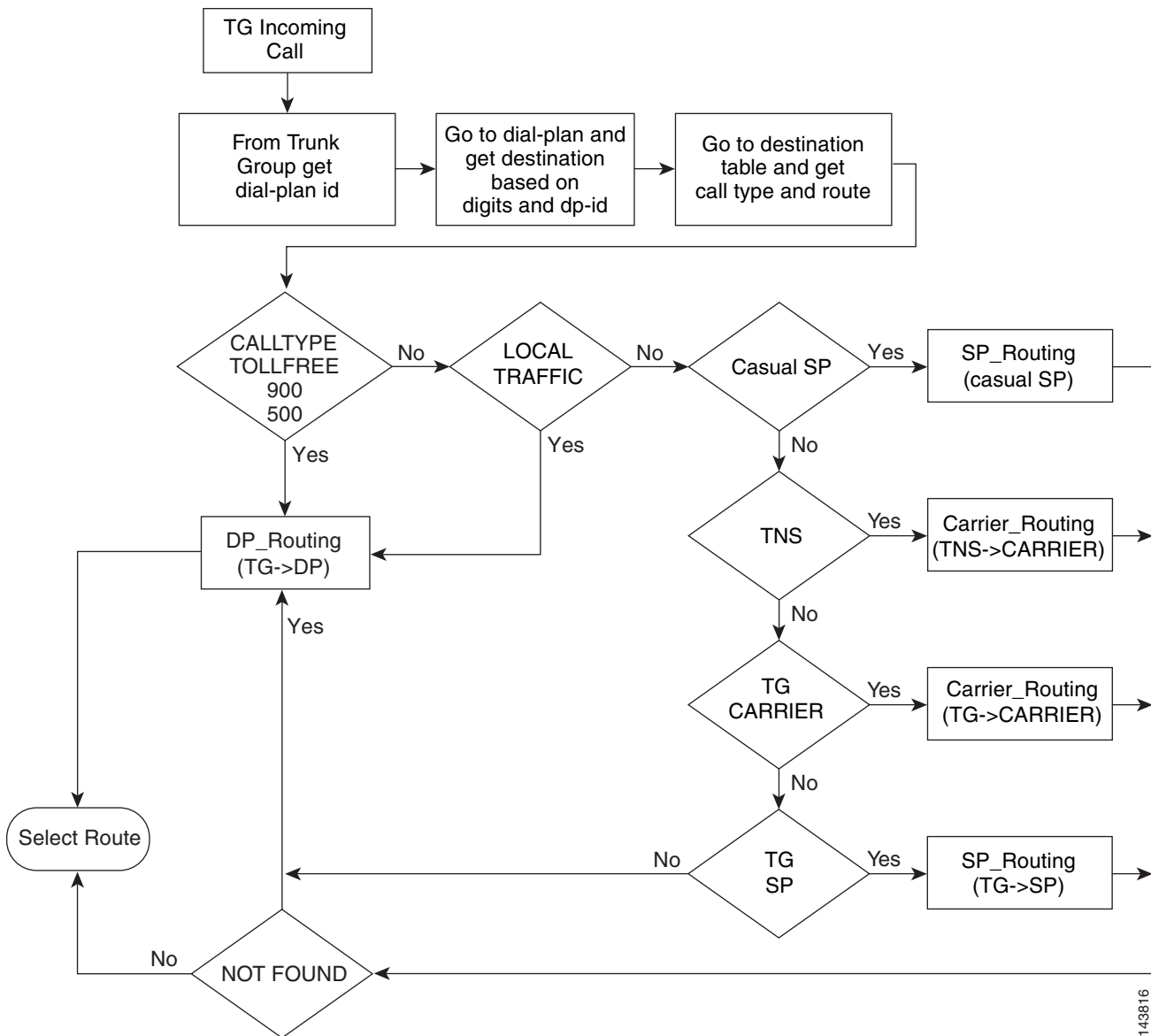

Service Provider Routing

This section describes the Cisco BTS 10200 service provider routing. Refer to [Figure 2-3](#) and review the following summary of service provider routing flow.

-
- Step 1** Service provider call received.
 - Step 2** Determine if service provider routing is available. If service provider routing is available, proceed to Step 3. If service provider routing is not available, proceed to Step 4.
 - Step 3** If service provider routing is available, the Cisco BTS 10200 uses the service provider dial plan to select the call route and to route the call. If the service provider dial plan cannot be found, proceed to Step 4.

- Step 4** If service provider routing is not available or if the service provider dial plan cannot be found, the Cisco BTS 10200 queries the service provider to determine which dial plan to use. If a trunk group dial plan is available, proceed to Step 5. If a trunk group dial plan is not available, proceed to Step 6.
- Step 5** If a trunk group dial plan is available, the Cisco BTS 10200 uses the trunk group dial plan to select the call route and to route the call.
- Step 6** If a trunk group dial plan is not available, the Cisco BTS 10200 queries the service provider route guide index to select the call route and to route the call.

Figure 2-3 Service Provider Routing

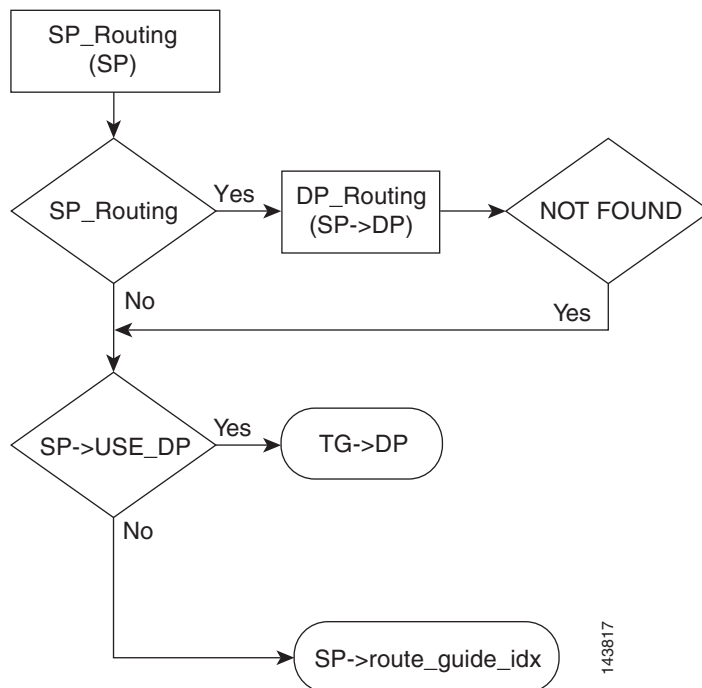

Carrier Based Routing

This section describes the Cisco BTS 10200 carrier based routing. Refer to [Figure 2-4](#) and review the following summary of carrier-based routing flow.

- Step 1** Carrier based routing call is received.
- Step 2** Determine if the carrier is being screened. If the carrier is being screened, proceed to Step 3. If the carrier is not being screened, proceed to Step 4.
- Step 3** If the carrier is being screened, the Cisco BTS 10200 determines if the carrier call processing is being remotely blocked (RTM_CP_BLOCK). If the carrier call processing is being remotely blocked, the call cannot be completed and will be dropped.
- Step 4** If the carrier is not being screened, the Cisco BTS 10200 determines if the carrier is a recognized service provider. If the carrier is a recognized service provider, proceed to Step 5. If the carrier is not a recognized service provider, proceed to Step 6.

- Step 5** If the carrier is a recognized service provider, the Cisco BTS 10200 uses the service provider routing to select the call route and to route the call.
- Step 6** If the carrier is not a recognized service provider, the Cisco BTS 10200 determines if a carrier dial plan is configured. If a carrier dial plan is configured, proceed to Step 7. If a carrier dial plan is not configured proceed to Step 8.
- Step 7** If a carrier dial plan is configured, the Cisco BTS 10200 uses the carrier dial plan to select the call route and to route the call.
- Step 8** If a carrier dial plan is not configured, the Cisco BTS 10200 determines if a carrier remote call processing to local exchange carrier operations support system is available (RTM_CP_CARRIER_2_LECOSS). If the RTM_CP_CARRIER_2_LECOSS is available, proceed to Step 9. If the RTM_CP_CARRIER_2_LECOSS is not available, proceed to Step 10.



Note Step 8 is skipped for toll traffic. For toll traffic, proceed to Step 10.

- Step 9** If the RTM_CP_CARRIER_2_LECOSS is available and if the traffic is not toll traffic, the Cisco BTS 10200 uses the RTM_CP_CARRIER_2_LECOSS to select the call route and to route the call.
- Step 10** If the RTM_CP_CARRIER_2_LECOSS is not available, the Cisco BTS 10200 uses the carrier guide index to select the call route and to route the call.
-

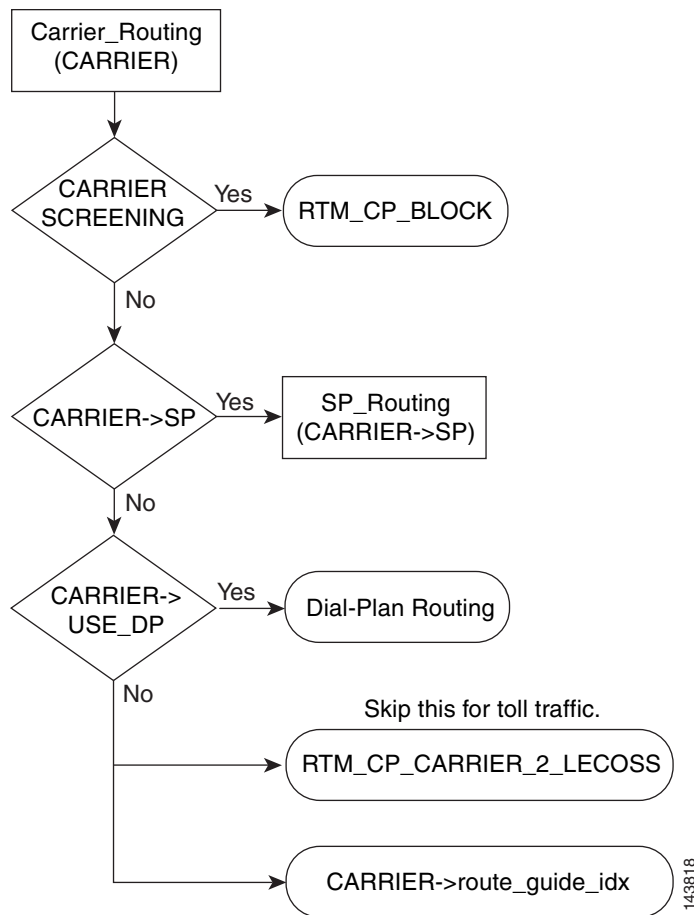
Figure 2-4 Carrier Based Routing

Basic Dial Plan Routing

This section describes the Cisco BTS 10200 basic dial plan routing. Refer to [Figure 2-5](#) and review the following summary of basic dial plan routing flow.

-
- Step 1** Basic dial plan routing call received.
 - Step 2** Determine if the NOA for the received call is an international call. If the call is an international call, the Cisco BTS 10200 uses the international dial plan to select the call route and to route the call. If the call is not an international call, proceed to Step 3.
 - Step 3** Determine if the call destination is found. If the call destination is not found, the Cisco BTS 10200 returns a destination not found response (not found) and will drop the call. If the call destination is found, proceed to the Step 4.
 - Step 4** Determine if a call destination subscriber is found. If a call destination subscriber is found, the Cisco BTS 10200 returns a subscriber (SUB) response and uses the subscriber information to select the call route and to route the call. If a call destination subscriber is not found, proceed to Step 5.

- Step 5** Determine if a call destination route is found. If a call destination route is found, the Cisco BTS 10200 returns a destination (DEST) response and uses the route guide index to select the call route and to route the call. If a call destination route is not found, proceed to Step 6.
- Step 6** Determine if a call destination route identification (RID) is found. If a call destination RID is found, the Cisco BTS 10200 returns a DEST response and uses the route index to select the call route and to route the call. If a call destination RID is not found, proceed to Step 7.
- Step 7** Determine if a destination carrier is found. If a destination carrier is found, proceed to Step 8. If a destination carrier is not found, the Cisco BTS 10200 returns an error and will drop the call.
- Step 8** Determine the call type. If the call type is toll free, 900, or 500, the Cisco BTS 10200 selects the call route and routes the call using the destination carrier routing. If the call type is not toll free, 900, or 500, the Cisco BTS 10200 returns an error and will drop the call.
-

Figure 2-5 Basic Dial Plan Routing

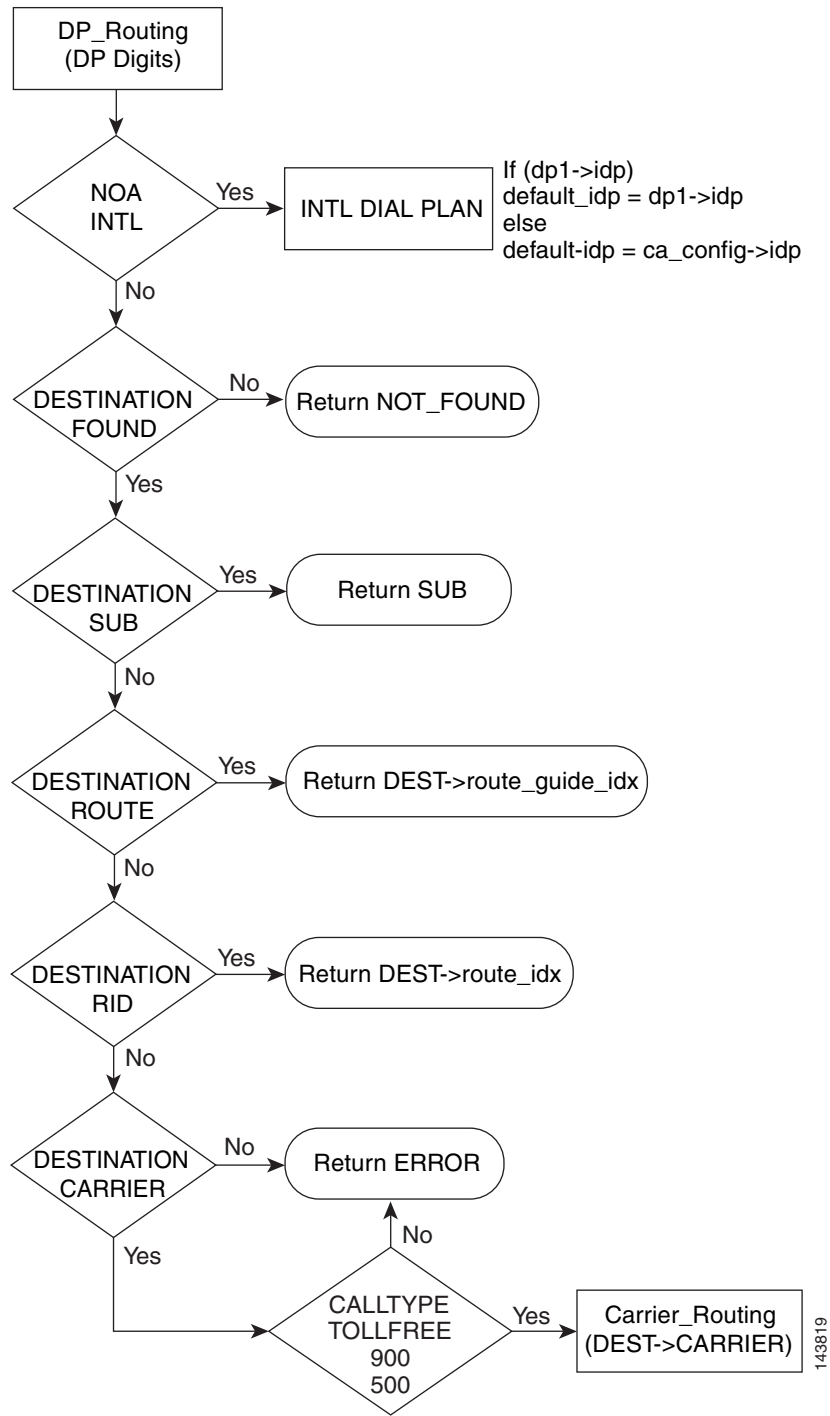

143819

ANI Based Routing

This section describes the Cisco BTS 10200 ANI based routing. Refer to [Figure 2-6](#) and review the following summary of ANI-based routing flow.

-
- Step 1** A TG incoming call is received.
 - Step 2** Get the dial plan ID from the TG.
 - Step 3** Go to the dial plan and get the call destination based on the digits and the dial plan ID.
 - Step 4** Go to the destination table and get the call type and call route.
 - Step 5** Check for the ANI based routing flag. If the ANI based routing flag is available, the Cisco BTS 10200 uses the ANI to determine the subscriber characteristics and then routes the call based on those characteristics. If the ANI based routing flag is not available, the Cisco BTS 10200 selects the call route and routes the call using normal TG routing.
-

Figure 2-6 ANI-based Routing

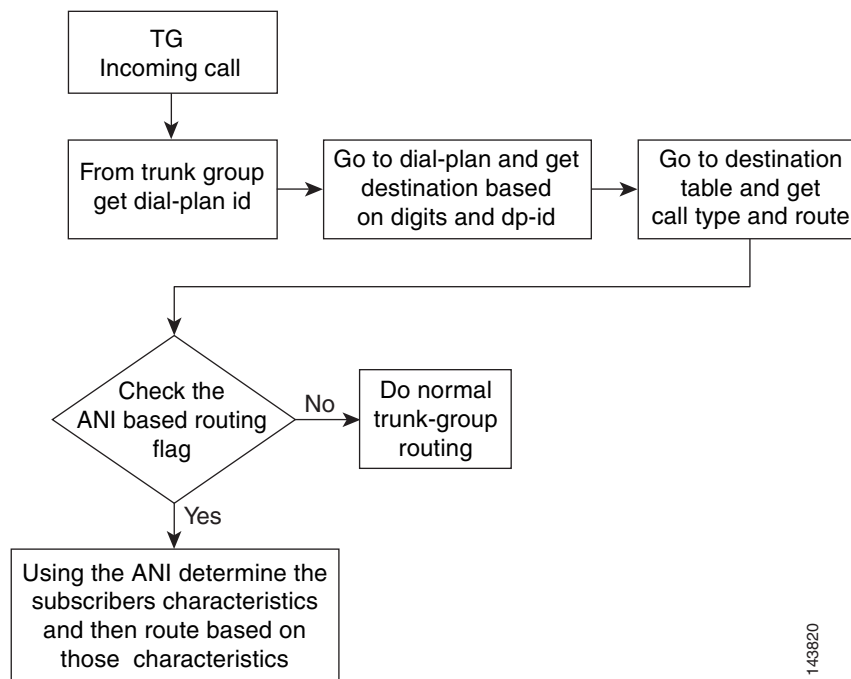

NOA Routing (ITU Local Number Portability)

NOA routing is used to select separate dial plans for DN and RN. The ISUP IAM CdPN parameter contains a NOA value. The NOA value distinguishes the format of the digits, that is, DN only vs. RN+DN. In some countries, DN prefixes can be the same as some RNs. In these cases, NOA routing allows the use of different dial plans for DN routing and RN routing.

For a call where the CdPN is a normal DN, the NOA is set to the ITU Q.769 value of 3, meaning national (significant) number. After a local number portability (LNP) query for a ported number, the CdPN consists of the RN and DN concatenated together. The ITU Q.769 NoA value of 8 is used to indicate that the CdPN is in the RN + DN format.

Routing Number

A RN, also known as a network routing number, is used to route the call to a ported number after an LNP query to the recipient network or switch. In some countries, the RN consists of a network ID plus an equipment ID. For example, in some countries, the RN consists of a 2-digit operator code plus a 2-digit equipment code. Together, the operator code and equipment code, combined as the RN, can be used to route to any possible recipient switch. In some countries, for example, Sweden, the RN contains only the network ID. The call is routed to the recipient, and then another LNP query is required in order for an RN to be obtained that identifies the specific recipient switch.

Switch Types

In LNP call scenarios, the Cisco BTS 10200 can be considered one of the following switch types:

- **Originating Switch**—Subscriber origination. An originating switch is the end office where a subscriber dials a ported directory number (DN). A switch that initiates call forwarding (CFU/CFB/CFNA) is considered the originating switch with respect to the forwarded leg of the call.
- **Transit Switch**—An incoming trunk call is routed out to another switch. Also known as an intermediate switch.
- **Donor Switch**—Processes a call originating from a subscriber or trunk to a called directory number (DN) of a subscriber ported out of the given Cisco BTS 10200 donor switch to a recipient switch. In some cases, the donor switch might also be the originating or intermediate switch.
- **Recipient Switch**—Receives a call originating from a subscriber or trunk and has a called DN of a subscriber ported in to the given Cisco BTS 10200. In some cases, the recipient switch might also be the originating switch.

Query Types

The Cisco BTS 10200 performs queries of the LNP database in order to route a call. It may also be configured to perform queries for another switch that is not capable of LNP queries.

ITU LNP supports the following query types:

- **ACQ**—An LNP query is performed by the Cisco BTS 10200 on all originating calls by Cisco BTS 10200 subscribers. In some cases, the Cisco BTS 10200 performs an ACQ for another switch that does not have the capability. This method is efficient for networks with many ported subscribers.
- **Query on Release**—A call is routed without a query. When it reaches the donor switch, the call is released backward with the QOR cause code of OOR: Ported Number (14). The originating switch receives the REL with QOR, performs the LNP query, and routes the call on to the recipient switch. This method is efficient for networks with few ported subscribers.
- **Onward Donor Based Routing**, also known as Onward Call Routing (OCR)—LNP queries are only performed in a donor switch when it is determined that the called party is ported-out of the switch. The donor switch performs the query and routes the call onward to the recipient switch. This method is efficient for networks with very few ported subscribers.

ACQ

ACQ, shown in Figure 2-7, usually applies to a subscriber origination (originating switch). A subscriber is ported out of the donor switch and ported in to the recipient switch. The ACQ is performed on the originating switch before the call is routed to the recipient switch. The originating switch queries the LNP database for the routing number of the ported switch.

Figure 2-7 ACQ

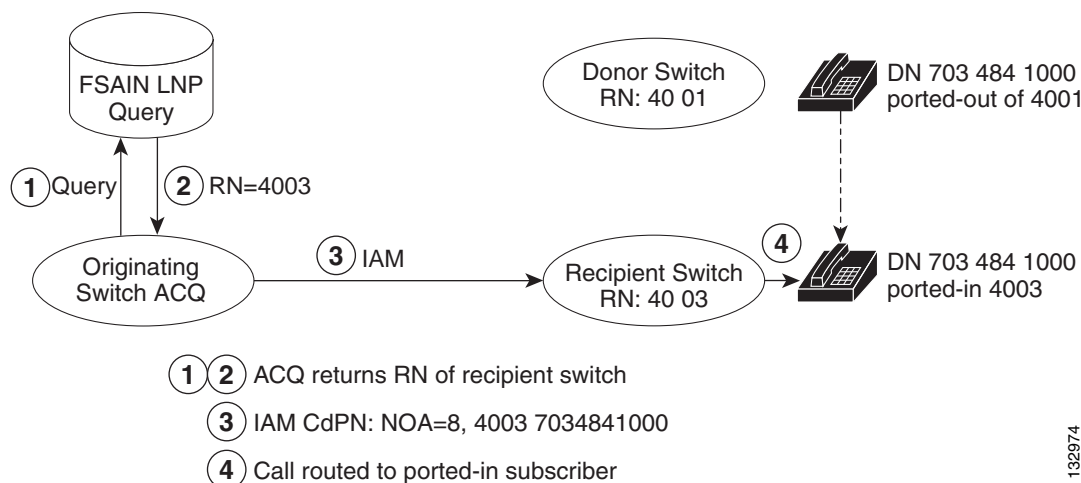

ACQ might also be performed by an intermediate or donor switch for another switch or network.

Intermediate or Donor Switch Performs ACQ for Another Switch or Network

The Cisco BTS 10200 might be required to perform ACQ for another switch that does not have that capability. For example, an international gateway exchange might not have access to the local country LNP database, so the ACQ is performed at the point of interconnect (POI) by the intermediate switch.

To configure the Cisco BTS 10200 to perform ACQ on incoming calls from a particular trunk group, set the ALL-CALL-QUERY=Y in the LNP Profile table and the token PERFORM-LNP-QUERY=Y in the incoming Trunk Group table.

A query is then performed on each call received from that trunk group unless the query is not allowed by the destination used for a particular call. For more information, see the “Destination Table ACQ Controls” section.

Destination Table ACQ Controls

- ACQ-LNP-QUERY=NA in the Destination table is used when an ACQ is not applicable, for example, when the country does not support LNP or ACQ or when the operator does not want the Destination table to have any effect on LNP queries as configured in the LNP Profile table and the Trunk Group table.

- ACQ-LNP-QUERY=LNP-QUERY-BASED-ON-CALL-TYPE in the Destination table is provided to allow or prevent ACQ queries for certain call types. For example, LNP queries should not be performed for emergency calls. When the ACQ-LNP-QUERY token is set to LNP-QUERY-BASED-ON-CALL-TYPE in the Destination table, the value of the LNP-QUERY token in the Call Type Profile table determines whether a query will be allowed for a given call type (and the value of the PERFORM-LNP-QUERY in the Trunk Group table, if the call is an incoming trunk group). For additional information on call types, refer to [Appendix A, “Call Types and Subtypes.”](#)



Note For call types emergency (EMG), fire, police, or ambulance an ACQ query is not performed under any circumstances.

- ACQ-LNP-QUERY=PERFORM-LNP-QUERY and ACQ-LNP-QUERY=NO-LNP-QUERY—ACQ queries are performed for a subset of calls based on the called number prefix. To support this requirement, ALL-CALLS-QUERY=Y in the LNP Profile table. In addition, calls to the specific prefixes requiring ACQ have dial-plan entries pointing to destinations with ACQ-LNP-QUERY, in the Destination table, set to PERFORM-LNP-QUERY. For calls to these ACQ destinations, if the call originates on a trunk, then the Trunk Group table PERFORM-LNP-QUERY also must be set to Y for a query to be performed.
- ACQ-LNP-QUERY=NO-LNP-QUERY—There is a requirement to block queries on outgoing carrier calls. The value ACQ-LNP-QUERY=NO-LNP-QUERY, in the Destination table, indicates that a query is not to be performed on any call to this destination.

ACQ and Call Forwarding

A call to a Cisco BTS 10200 subscriber can be forwarded to another number, for example, in the case of CFU, CFB, or CFNA. For the purposes of LNP, the forwarded call is considered a new subscriber origination, and the switch where the forwarding occurs is the originating switch. If ACQ is configured, a query is performed on the forwarding leg through use of the forwarded-to DN.

ACQ Matrix

[Table 2-1](#) and [Table 2-2](#) illustrate which token combinations result in a query. In general, a query must be allowed at all applicable levels for a query to be performed. For each row in the table, the particular combination of LNP-Profile table ALL-QUERY=Y/N, Destination table ACQ-LNP-QUERY value, plus Call Type Profile value, where applicable, result in a Cisco BTS 10200 ACQ query being performed or not performed.

Table 2-1 Subscriber Origination ACQ Matrix

LNP Profile ALL-CALL-QUERY	Destination ACQ-LNP-QUERY= NA	Destination ACQ-LNP-QUERY= PERFORM-LNP- QUERY	Destination ACQ-LNP-QUERY= NO-LNP-QUERY	Destination (ACQ-LNP-QUERY= ACQ-BASED-ON- CALL-TYPE) and (Call-Type-Profile for Call Type LNP-QUERY=Y	Destination (ACQ-LNP-QUERY = ACQ-BASED-ON- CALL-TYPE) and (Call-Type-Profile for Call Type Not Present or LNP-QUERY=N	BTS ACQ Query Per- formed ?
Y	X					Y
Y		X				Y
Y			X			N
Y				X		Y
Y					X	N
N	X					N
N		X				N
N			X			N
N				X		N
N					X	N

Table 2-2 Trunk Origination ACQ Matrix

LNP Profile ALL-CALL- -QUERY	Incoming Trunk Grp PERFORM- LNP-QUERY	Destination ACQ-LNP- QUERY=NA	Destination ACQ-LNP- QUERY= PERFORM- LNP-QUERY	Destination ACQ-LNP- QUERY= NO-LNP- QUERY	Destination (ACQ-LNP- QUERY= ACQ-BASED-ON- CALL-TYPE) and (Call-Type-Profile for Call Type LNP-QUERY=Y	Destination (ACQ-LNP- QUERY= ACQ-BASED-ON- CALL-TYPE) and (Call-Type-Profile for Call Type Not Present or LNP-QUERY=N	BTS ACQ Query Performed?
Y	Y	X					Y
Y	Y		X				Y
Y	Y			X			N
Y	Y				X		Y
Y	Y		-	-	-	X	N
Y	N	X					N
Y	N		X				N
Y	N			X			N
Y	N				X		N
Y	N					X	N
N	Y	X					N
N	Y		X				N
N	Y			X			N
N	Y				X		N
N	Y		-	-	-	X	N
N	N	X					N
N	N		X				N
N	N			X			N
N	N				X		N
N	N					X	N

Query on Release

For Query on Release (QOR), illustrated in [Figure 2-8](#), calls are routed normally, with no LNP query, until a call is received for a ported-out subscriber at the donor switch. The donor switch supporting QOR clears the call and sends backward release (REL) with the QOR cause code specified by the network. The cause value QOR: Ported Number (14) is in ITU/ETSI networks. Each intermediate/transit switch in turn clears backward with the same QOR release cause until finally the originating switch receives the backward REL. This originating switch performs the QOR query and re-routes the call onward towards the recipient switch.

Figure 2-8 QOR

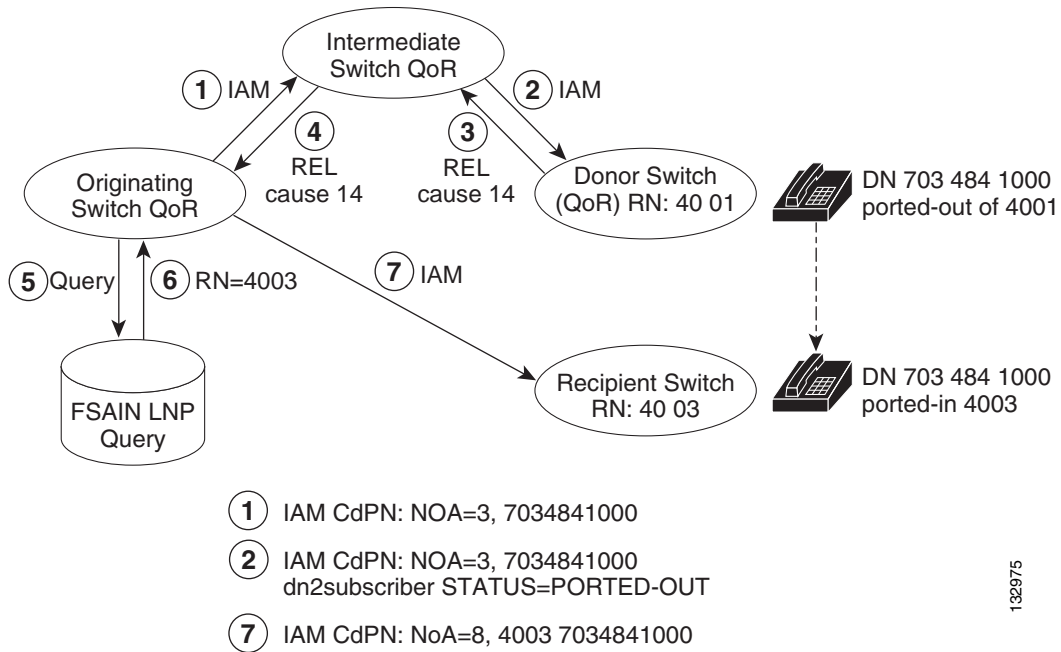

A Cisco BTS 10200 is configured for QOR when the LNP Profile Table's QUERY-ON-RELEASE token is set to Y.



Note

For a call terminating to a ported-out subscriber (donor switch), ODBR takes precedence over QOR. For a subscriber origination (originating switch), ACQ takes precedence over QOR, so the call will be initially correctly routed to the recipient switch, and no REL with cause value QOR: Ported Number (14) is received (other than for a network routing error).

The Cisco BTS 10200 performs one of the following functions for QoR:

- Donor Switching
- Intermediate or Transit Switching
- Originating Switching

Donor Switching

- Normal case—When the Cisco BTS 10200 receives a call to a DN with a DN2subscriber record, if the status has a value of PORTED-OUT, and if the LNP Profile table indicates QUERY-ON-RELEASE=Y, then a backward release (REL) is sent with the QOR ported number release cause defined in the LNP Profile table (defaults to cause value QOR: Ported Number (14)).
- QOR not supported by backward switch—For a trunk originated call to a ported-out subscriber, the incoming trunk group may indicate that QOR is not supported by the previous switch or network and that the Cisco BTS 10200 is expected to perform the QOR query (LNP Profile table QUERY-ON-RELEASE=Y and Trunk Group table PERFORM-LNP-QUERY =Y). In this case, a QOR query is performed by the Cisco BTS 10200 and the call is re-routed onward to the recipient switch.

- Misrouted call or configuration error—If the dn2subscriber record status has a value of PORTED-OUT, but the LNP Profile table QUERY-ON-RELEASE=N and ONWARD-CALL-ROUTING=N, a network routing error has occurred (for example, the CRD LNP database is incorrect, the originating switch performing ACQ misrouted the call, or the Cisco BTS 10200 DN2subscriber or LNP Profile flags are incorrect). For a misrouted call where the CdPN contained a regular non-ported DN, the Cisco BTS 10200 will clear the call with a non-LNP release cause indicating an unallocated number; otherwise, if the CdPN contained the ported NOA as a result of the incoming trunk call or subscriber origination on this switch, then the cause misrouted ported number is used.

Intermediate or Transit Switching

- Normal case—When the Cisco BTS 10200 receives a backward REL with the QOR ported number release cause, the Cisco BTS 10200 clears the call and sends a backward REL with the same release cause.
- QOR not supported by backward switch—If the incoming trunk group indicates that QOR is not supported by the previous switch or network and that the Cisco BTS 10200 is expected to perform the QOR query (LNP Profile table QUERY-ON-RELEASE=Y and Trunk Group table PERFORM-LNP-QUERY=Y), a QOR query is performed by the Cisco BTS 10200 and the call is re-routed onward to the recipient switch.

Originating Switching

- Normal case—When the Cisco BTS 10200 receives a backward REL with the QOR ported number release cause, if the LNP Profile table QUERY-ON-RELEASE=Y, a query is performed. The call is then re-routed onward to the recipient switch.
- When the Cisco BTS 10200 receives a backward REL with cause QOR: Ported Number (14), if the LNP Profile table QUERY-ON-RELEASE=N, this cause value is not defined as a QOR ported number cause value.
- When the Cisco BTS 10200 receives a backward REL with the QoR ported number release cause, and the LNP Profile table QUERY-ON-RELEASE=Y, if the Cisco BTS 10200 determines that a query was done previously (ACQ) and did not find an RN and the call was routed with the DN, the call is cleared with a cause unallocated number.
- When the Cisco BTS 10200 receives a backward REL with the QOR Ported Number release cause, if the Cisco BTS 10200 determines that a query was done previously (ACQ) that returned an RN, and the call was routed using the RN and NOA for ported number, then the call is cleared with a cause 31 unspecified. This case is normally not expected to occur. If the Cisco BTS 10200 is the donor switch in this case and receives a called party number with ported NOA, then REL with cause unallocated number is sent back to the originating switch. Cause QoR: Ported Number (14) is not used for an incoming call containing a ported number NOA.

Intermediate or Donor Switch Performing QoR for Another Switch or Network

For QoR, the LNP query is only done on the originating switch, unless the Cisco BTS 10200 is required to perform the QoR query for another switch that does not have that capability. For example, an international gateway exchange might not have access to the local country-specific LNP database, so the query is performed by the intermediate switch.

QoR and Call Forwarding

A call terminating to a Cisco BTS 10200 subscriber might be forwarded to another number, for example, in the case of CFU, CFB, or CFNA. In the case of LNP, the forwarded call is considered a new subscriber. If a backward REL with the ported number release cause is received, and QoR is configured, a query is performed to route the forwarding leg to the new recipient switch.

Onward Donor Based Routing

For Onward Donor Based Routing (ODBR), also known as Onward Call Routing (OCR), LNP queries are performed in a donor switch. The called party number is used to access the DN2subscriber table and, if the STATUS=PORTED-OUT or LNP-TRIGGER=Y, an LNP query is performed. After the query, the donor switch routes the call onward to the recipient switch.

ODBR is illustrated in [Figure 2-9](#).

Figure 2-9 ODBR Routing

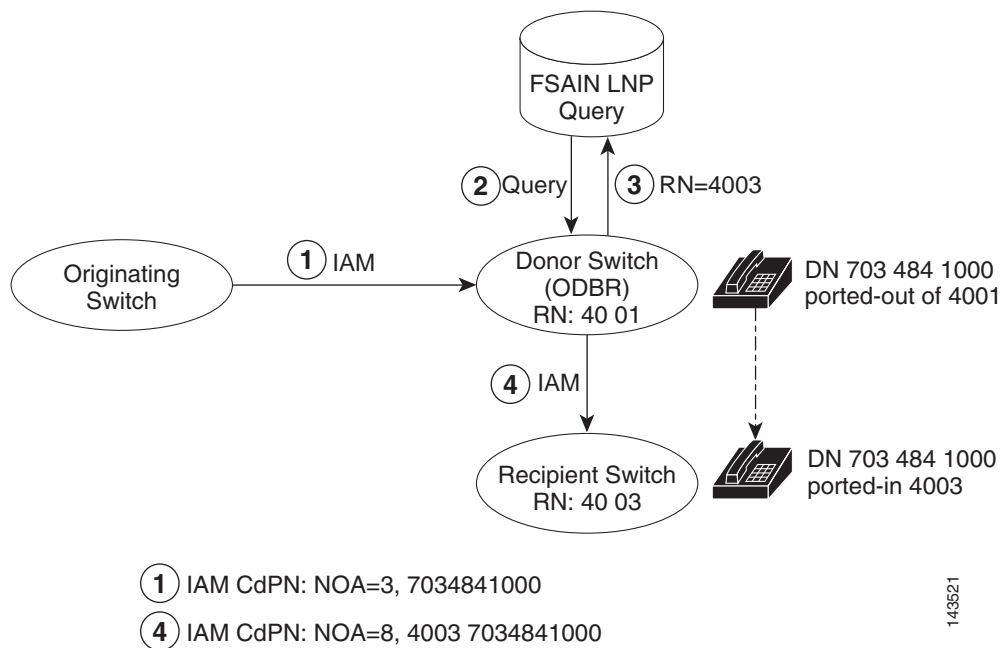

Subscriber Based LNP Trigger on a Donor Switch

The LNP-TRIGGER token in the DN2subscriber table provides an alternative to porting. The alternative method is enabled by changing the DN2subscriber status token to PORTED-OUT. It allows a seamless transition on a donor switch. However, it is not recommended if porting procedures normally require provisioning changes at the time the porting becomes effective.

During the transition period of a local subscriber porting out, the DN2subscriber record LNP-TRIGGER token might be set to Y, which forces an LNP query to determine whether the LNP database indicates the subscriber's DN is ported out or not.

If the LNP query returns an RN for a different switch, then the subscriber has ported out. In this case, if the switch performs ODBR queries, the call is routed onward to the recipient switch; otherwise, if the switch is configured for QoR queries, the donor switch sends backward REL with the QoR cause code.

If the LNP query does not find an RN, or returns the RN of this switch, then the subscriber is not ported yet (or has ported out and back in again), so the call is routed to the subscriber.

The subscriber-based LNP trigger makes it easy for the operator because configuring of the subscriber ported status is not required to be synchronized with the porting window. The operator sets the subscriber ported status (LNP-TRIGGER) flag in advance of the porting time window and can set the subscriber status to PORTED-OUT sometime later, after the porting.

**Note**

The LNP-TRIGGER flag is not applicable for ACQ.

Example 1: QoR Donor Transition Period

Figure 2-10 and Figure 2-11 illustrate a call scenario for a QoR donor transition period. In Figure 2-10, the subscriber is ported out, the LNP-TRIGGER token has been set to Y, and the local database has no entry.

Figure 2-10 Before Subscriber Porting

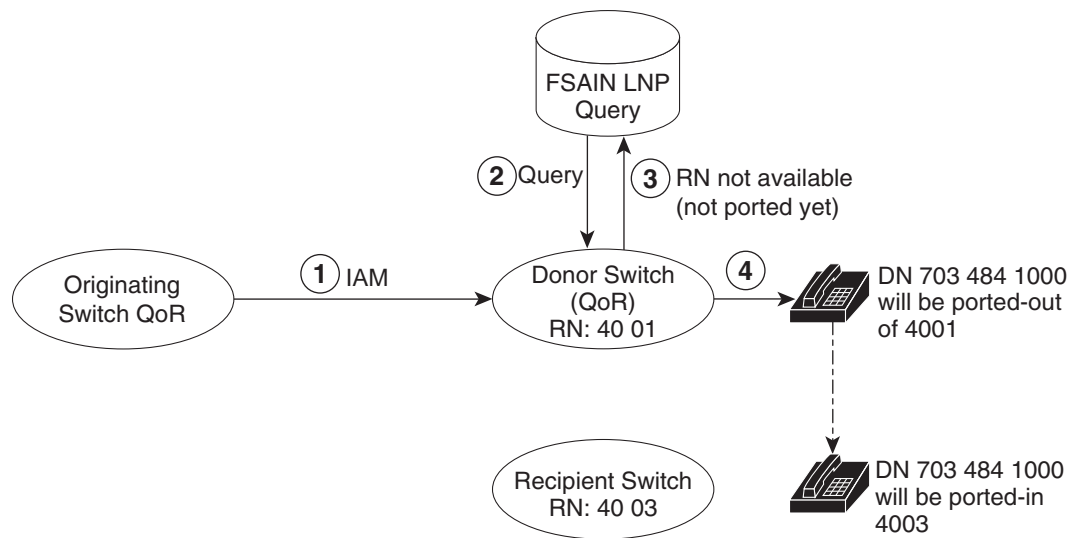

- ① IAM CdPN: NOA=3, 7034841000
- ② dn2subscriber STATUS=ASSIGNED dn2subscriber LNP-TRIGGER=Y
- ③ Donor LNP query indicates sub not ported yet (no RN)
- ④ Route call to local sub

143522

1. The originating switch sends an IAM to the donor switch with NOA=3 and DN=7034841000.
2. In the DN2subscriber table on the donor switch, STATUS=ASSIGNED and LNP-TRIGGER=Y. Since the LNP-TRIGGER=Y, the donor switch performs a query.
3. The query does not return an RN to the donor switch, indicating that the subscriber is not yet ported out.
4. The donor switch routes the call to the local subscriber.

Example 2: QOR Donor Transition Period

In Figure 2-11, it is after the start of the porting window. The subscriber is ported out, and the LNP-TRIGGER token has been set to Y. The local database now shows the subscriber as ported out (contains an RN for the subscriber).

Figure 2-11 After Subscriber Porting

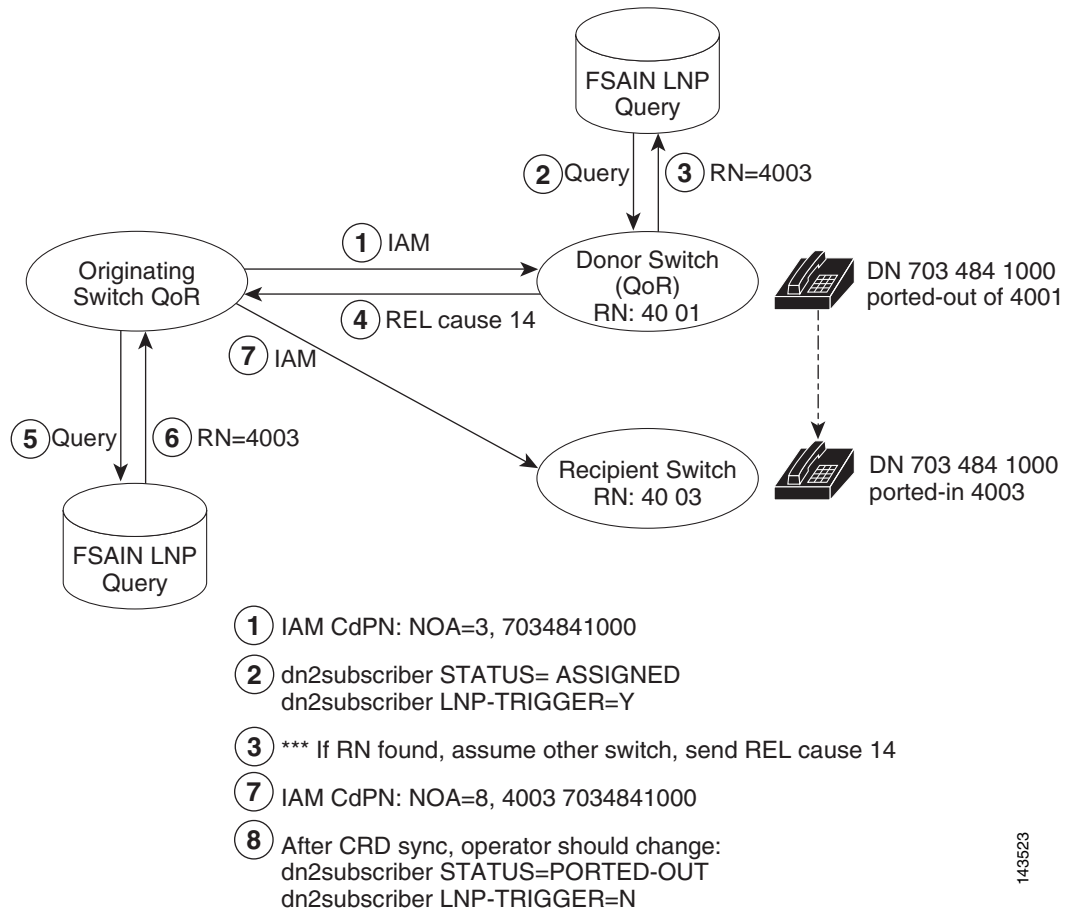

143523

1. The originating switch sends an IAM to the donor switch with NOA=3 and DN=7034841000.
2. In the DN2subscriber table on the donor switch, STATUS=ASSIGNED and LNP-TRIGGER=Y. Since the LNP-TRIGGER=Y, the donor switch performs a query.
3. The query returns RN=4003.
4. The donor switch sends REL cause QoR: Ported Number (14) to the originating switch.
5. The originating switch performs an LNP query of its local database.
6. The query returns RN of the recipient switch.
7. The originating switch sends an IAM to the recipient switch.

Precedence of Query Types

Operators can choose different options among ACQ, ODBR, QoR, and a combination of these. Countries starting with only ODBR or QoR may eventually transition to ACQ as more numbers become ported. Therefore, during the transition, a given network or switch may be a combination of ACQ plus QoR or ACQ plus ODBR.

The Cisco BTS 10200 LNP Profile tokens for ALL-CALLS-QUERY (ACQ), ONWARD-CALL-ROUTING (ODBR), and QUERY-ON-RELEASE (QoR) give the operator complete flexibility to configure the Cisco BTS 10200 for any possible combination in a mixed network by simply changing the LNP Profile tokens.

In general, ACQ takes precedence over ODBR, which takes precedence over QoR, and finally LNP-TRIGGER. A query due to ODBR or QoR requires the called DN status, in the dn2subscriber table, to be PORTED-OUT. For a query to result from LNP-TRIGGER=Y, the dn2subscriber status cannot be PORTED-OUT (and either the ONWARD-CALL-ROUTING or QUERY-ON-RELEASE must be Y).

[Table 2-3](#) illustrates query type precedence. The first five columns indicate configuration values, and the last four columns indicate whether a query is performed or another action on the respective originating, intermediate, donor, and recipient switches. Note the following for [Table 2-3](#):

- N values (for example, LNP Profile table ALL-CALL-QUERY=N) are shown as a blank cell in the table, to improve readability.
- ODBR indicates an all call query is performed, and the call is routed onward to the recipient switch.
- REL indicates the donor switch detects that the subscriber is ported-out, so the call is cleared (REL with cause QoR: Ported Number (14)).
- REL QOR indicates the originating switch receives REL with cause QoR: Ported Number (14), does a query, and routes the call onward to the recipient switch.

Table 2-3 Precedence of Query Matrix

LNP Profile ALL-CALL- QUERY	LNP Profile ONWARD- CALL- ROUTING	LNP Profile QUERY-ON- RELEASE	DN2SUB- SCRIBER Status PORTED- OUT)	DN2SUB- SCRIBER LNP-TRIGGER (and not PORTED-OUT)	Trunk Grp PERFORM- LNP-QUERY	Originating Switch Query?	Inter- mediate Switch Query?	Donor Switch Query?	Recipient Switch Query?
Y						ACQ			
	Y		Y					ODBR	
		Y				REL QOR		REL	
				Y				Note 3 ¹	
					Y				
Y	Y		Y			ACQ		ODBR	
Y		Y	Y			ACQ		REL	
Y				Y		ACQ		Note 3	
Y					Y	ACQ	ACQ	ACQ	
	Y	Y	Y					ODBR	
	Y			Y				Note 1 ²	
	Y		Y		Y			ODBR	
		Y		Y				Note 2 ³	
		Y			Y	REL QOR	REL QOR	REL QOR	
Y	Y	Y	Y			ACQ		ODBR	
Y	Y	Y		Y		ACQ		Note 1	
Y	Y	Y			Y	ACQ	ACQ	ACQ	
Y	Y	Y		Y	Y	ACQ	ACQ	ACQ	

1. Donor switch dn2subscriber LNP-TRIGGER=Y, but not ODBR or QoR. Route call to subscriber with no query.
2. Case A: Donor switch dn2subscriber LNP-TRIGGER=Y and dn2subscriber STATUS=PORTED-OUT with ONWARD-CALL-ROUTING=Y: ODBR query. If query result returns an RN and if the RN is for another switch, the call is routed onward to the recipient switch; otherwise, the call cannot be routed to the ported-out subscriber, so the call fails with unallocated number cause.

Case B: Donor switch dn2subscriber table LNP-TRIGGER=Y and dn2subscriber table STATUS=ASSIGNED with ONWARD-CALL-ROUTING=Y: LNP-TRIGGER query. If query result returns an RN and if the RN is for another switch, the call is routed onward to the recipient switch; otherwise, the call is routed to the local subscriber
3. Case A: Donor switch dn2subscriber table LNP-TRIGGER=Y with QUERY-ON-RELEASE=Y and dn2subscriber STATUS=PORTED-OUT: Call is cleared backward with REL and QOR: ported number cause.

Case B: Donor switch dn2subscriber table LNP-TRIGGER=Y with QUERY-ON-RELEASE=Y and dn2subscriber table STATUS=ASSIGNED: LNP-TRIGGER query. If query result returns any RN or other switch, then the call is failed with QoR release cause such as unallocated number (not cause QoR: Ported Number (14)). Otherwise, an attempt is made to route the call to the local subscriber.

Dial Plan and NOA Routing

In some countries, there may be an overlap between the RNs and the leading digits of a DN; that is, the beginning digits of an RN and DN may be the same. The NOA is used to distinguish a DN from a concatenated RN + DN combination. A new capability, NOA routing, is added to the Cisco BTS 10200 for LNP in order to associate different dial plans for DN routing and RN routing.

Normal dial plans for subscriber and trunk originations are used to route to DNs. The new NOA Route table contains ported NOA values and destination IDs which point to RN dial plans.

Examples illustrating NOA routing are provided below. For the dial plan used for the subscriber or trunk origination, the dial-plan-profile table new NOA-ROUTING field is set to Y, with an associated NOA-ROUTE-PROFILE-ID. The new NOA Route table associated with the NOA Route Profile table has entries for the ported NOA. The NOA Route ITU Q.769 value 8, specified as PORTED-NUMBER-WITH-RN in the NOA Route table entry). If a matching NOA is found in the NOA Routing table, then the destination in the NOA Routing entry is used to route the call, and possibly point to a new dial plan for routing based on the RN. The call scenarios in the following sections show how this works.

Normal Routing for Called Party Number with a Non-Ported Nature of Address with Directory Number

An incoming trunk call is received with the Called Party Number containing the NOA associated with a DN. There will be no matching entry in the NOA Route entry. The normal dial-plan associated with the incoming trunk group is used to route the call.

Routing Number Routing for Called Party Number With Ported Nature of Number and Routing Number + Directory Number

An incoming trunk call is received with the Called Party Number containing the NOA associated with a ported DN. There is a matching entry in the NOA Route entry and a destination ID. That is, the NOA Route entry matches with the NOA entry of PORTED-NUMBER-WITH-RN (which is the value associated with NOA ITU Q.769 value 8). This destination ID may then contain a dial-plan ID for a dial plan for RN routing.

Local Number Portability Query Returns Routing Number for Ported Directory Number

When the Cisco BTS 10200 performs an LNP query and finds an RN for a ported number that is not in this switch, the call is routed onward. The dial-plan-profile associated with the originating subscriber or trunk has NOA-ROUTING=Y, and the NOA Route Profile ID of the NOA Route that contains a destination ID. Note that for a country such as France, which uses an RN prefix but with a standard NOA (3, National), after an LNP query on the Cisco BTS 10200, digit manipulation must be used to replace the NOA value ported- number with RN value to national.

Cluster Routing

A cluster is defined as two or more Cable Management Servers (CMSs) along with Media Gateway Controllers (MGCs) (or combined CMS/MGCs) deployed within a network. The cluster appears as one logical CMS/MGC looking towards the public switched telephony network (PSTN). The following assumptions are made:

- Each CMS, MGC, or combined CMS/MGC has its own SS7 Point Code.
- A trunk group cannot be split across multiple MGCs.
- All CMSs within a cluster share a common Location Routing Number (LRN) (referred as Cluster LRN).
- The npa-nxx of the ported-in numbers is not split across multiple CMSs (unless there is a NRS in the network).
- The subscriber DNs cannot be ported-out within a cluster.

A Cluster LRN is a shared LRN across multiple CMS/MGCs within a cluster.

When a call with cluster LRN is received by one of the CMSs (or MGCs) within a Cluster, the call is routed to the terminating CMS by a SIP route proxy with ENUM querying capability or by the npa-nxx of the called number. For additional information on ENUM, refer to [Chapter 4, “Electronic Number Mapping and Routing.”](#)

For Automatic Recall (AR) and Automatic Callback (AC) feature support, the ITP performs 6-digit GTT (npa-nxx) to route AR or AC requests to the appropriate CMS.

The CLRN is treated as admin-DN for purposes of Numbering Resource Utilization/Forecast (NRUF) reporting.

[Figure 2-12](#) illustrates the cluster routing scenarios.

Figure 2-12 Cluster Routing Scenarios Overview

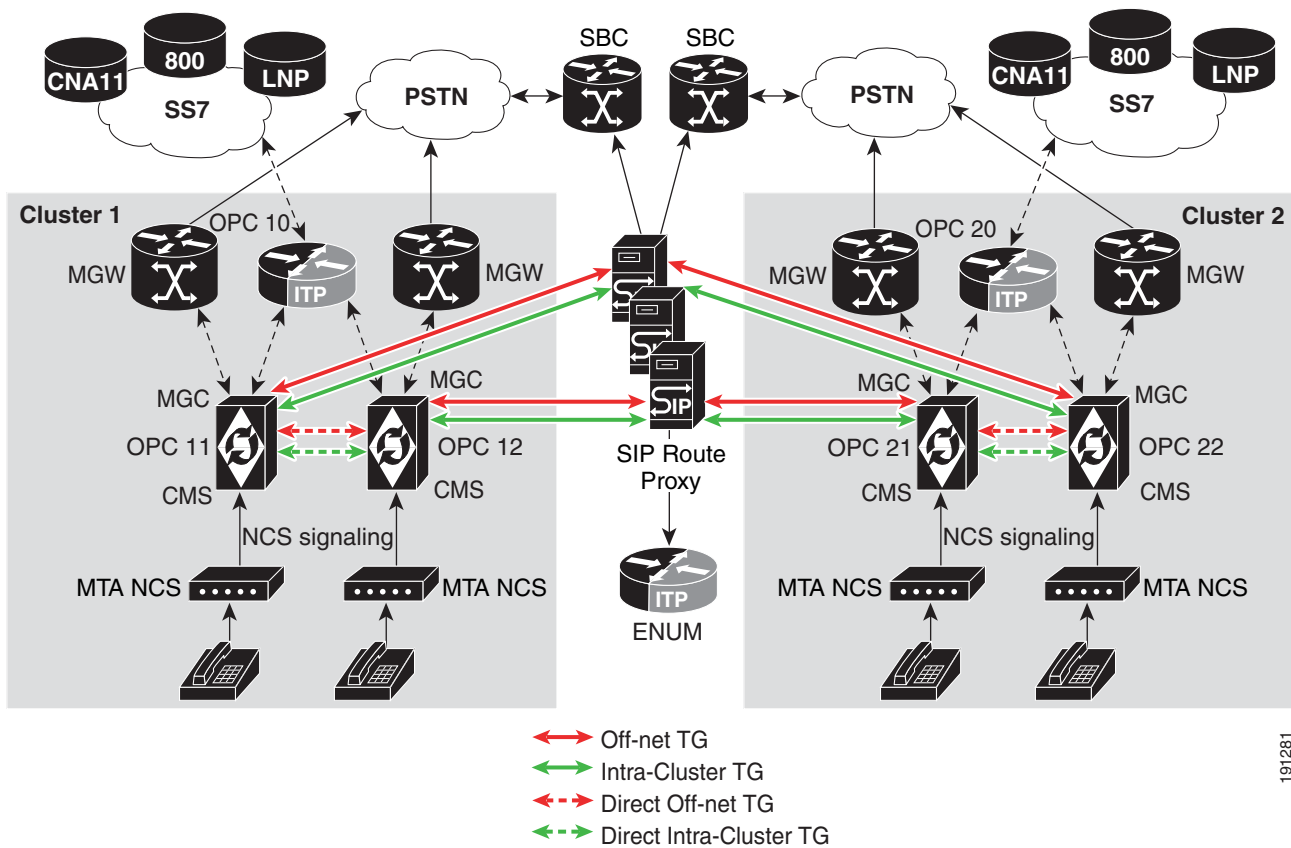

Subscriber Originated Call at CMS

When a subscriber originates a call and the dialed DN is not within the CMS, the call processing logic performs an LNP query if required. Here are the call processing steps:

- Step 1** If dialed DN exists in the Dn2Subscriber table and unconditional LNP Trigger is not set and status not equal to ported-out, then complete the call locally to the dialed DN. If status is not equal to assigned, then provide necessary treatment (for example, changed number, disconnect number, and so forth).
- Step 2** If dialed DN exists in the Dn2Subscriber table with unconditional LNP Trigger set (LNP-TRIGGER=Y), then perform LNP query.
 - If received LRN is MY-LRN or CLRN, then complete the call locally to the dialed DN. Otherwise, route the calls based on the LRN.
 - If no LRN is returned and route-type=SUB in the Destination table, then complete the call locally to the dialed DN. Otherwise, route the call based on the Dialed DN.
- Step 3** If dialed DN exists in Dn2Subscriber table and STATUS=PORTED-OUT, then perform LNP query. The call is routed based on the received LRN. If My-LRN or CLRN is received, treat it as an error condition.
- Step 4** If dialed DN does not exist in the Cisco BTS 10200 (after an LNP query is completed), the LRN Type is MY-LRN and the call is rejected.

Step 5 If the dialed DN does not exist in the Cisco BTS 10200 and the ROUTE-TYPE=SUB in the Destination table, then provide unallocated number treatment.

Step 6 If dialed DN does not exist in Cisco BTS 10200 and LRN Type is CLRN, then call is routed based on the dialed DN and not the CLRN. If Cluster Dial Plan ID is provisioned, then retranslate the call based on npa-nxx of the dialed number using Cluster Dial Plan ID. Otherwise route the calls based on the original Dial Plan ID.

**Note**

If a SIP route proxy is included in the cluster, then Cluster Dial Plan ID is not required. The subscriber dial plan ID should point all outgoing calls towards the SIP route proxy.

**Note**

In any case, the call should be routed with LNP information (M-bit, GAP, RN).

Step 7 If the dialed DN does not exist in Cisco BTS 10200 and,

- If the received LRN is not MY-LRN or CLRN, then the call is routed based on the received LRN.
- If an LNP query is performed, but no LRN is received, then the call is routed based on the dialed number.
- If no LNP query is performed, then the call is routed based on the dialed number

Call Processing at Terminating CMS/MGC

Here are the call processing steps at the terminating CMS (or combined CMS/MGC):

Step 1 When an inbound call is received over an intra-cluster TG and the LRN Type is MY-LRN or CLRN, and DN appears in the DN2Subscriber table, complete the call locally.

Step 2 When an inbound call is received over an intra-cluster TG and LRN Type is MY-LRN or CLRN and DN does not appear in the DN2Subscriber table, and the ROUTE-TYPE does not equal SUB, return cause code (26), misrouted ported number.

Step 3 When an inbound call is received over an intra-cluster TG with MY-LRN or CLRN, and DN does not appear in the DN2Subscriber table, and the ROUTE-TYPE equals SUB, return cause code (1), unallocated number.

Step 4 When an inbound call is received over an intra-cluster TG and LRN Type is not MY-LRN or CLRN, route the call based on the Called Party Number (CdPN).

Step 5 When an inbound call is received over an offnet TG and LNP query has not been performed by the originating CMS, the MGC performs an LNP query if required. The calls are routed as specified in the [“Inbound Call Processing at MGC from PSTN”](#) section.

Inbound Call Processing at MGC from PSTN

**Note**

IntraCluster TG flag is not set here.

The call processing steps at an MGC are very similar to those for the originating CMS. The call routing is configured based on the origin of the call. If the call originates from PSTN, configure the Cisco BTS 10200 as follows:

-
- Step 1** If CLRN is received and the dialed DN (GAP number) exists in the DN2Subscriber table, terminate the call locally.
- Step 2** If CLRN is received, route the call based on the npa-nxx of the dialed DN (GAP number) using Cluster Dial Plan ID if it exists or the original dial plan ID assigned to the inbound TG.
- Step 3** If an MY-LRN is received, the dialed DN must belong to the Cisco BTS 10200. Terminate the call to the dialed DN within the Cisco BTS 10200 (existing processing).
- Step 4** If no LRN is received, route the call based on the npa-nxx of the CdPN.
- Step 5** If an inbound call is received from PSTN and LNP query has not been performed, the MGC performs an LNP query if required. The calls are routed as follows:
- If CLRN is received, see Steps 1 and 2.
 - If MY-LRN is received, see Step 3.
 - If no-LRN is received, see Step 4.
 - If LRN TYPE is not MY-LRN or CLRN, the call is routed based on the received LRN.
-

**Note**

If the digits could not be found in the cluster dial plan or the default dial plan, the call is torn down.

Support for ietf Trunk Group Draft

The Cisco BTS 10200 is enhanced to support standards-based TGID for SIP trunks without affecting the existing proprietary TGID feature. The draft-ietf-iptel-trunk-group-08.txt specifies support for both originating and terminating trunk groups. Only originating trunk groups are supported in Cisco BTS 10200 Release 5.0. The originating trunk group is specified in the trunk group parameter in a SIP contact header.

Define DN as a Cluster LRN

The DN STATUS=CLRN is defined in the Dn2Subscriber table. The CLRN indicates to call processing that this is a cluster LRN (CLRN).

DN to Subscriber

The Element Management System (EMS) automatically generates the DN to Subscriber table. A user can show data or change the Status field to vacant if the EMS is in the disconnected (DISC) or connected (CN) state. The DN2Subscriber table determines the subscriber ID of a DN during termination processing. The table is populated when a subscriber DN is added to the Subscriber table. The table is

queried when the called number is translated by use of the dial plan and the type of subscriber field indicates Subscriber; that is, it takes a DN and maps it to a subscriber. The DN to Subscriber table also displays the administrative status of the DN. For token names and description details for the DN to Subscriber table, refer to the [Cisco BTS 10200 Softswitch CLI Database](#).

Define Cluster Dial Plan ID

When the dialed number is recognized as an intracenter DN (based on the returned LRN), the call is routed within the cluster by translation of the npa-nxx of the dialed DN by means of the cluster Dial Plan ID. The cluster Dial Plan ID is defined in the CA_CONFIG table.

Call Agent Configuration

The Call Agent Configuration (ca-config) table defines the values that a service provider is allowed to change. The Call Agent Configuration Base defines the defaults for each Call Agent and is used unless the Call Agent Configuration table is added with a different value. For token names and description details for the Call Agent Configuration table, refer to the [Cisco BTS 10200 Softswitch CLI Database](#).

Define Intracenter TG Flag

The intracenter TG flag is defined in the Trunk Group table. When this flag is set, and calls with MY-LRN or CLRN are received over this TG, the Cisco BTS 10200 should not reroute the calls to another Cisco BTS 10200 or to SIP Route Proxy if the DN is not found. Instead, it should return a cause code 1 or 26. For Trunk Group table details, refer to the [“Trunk Group” section on page 1-24](#).

Softswitch Trunk Group Profile Table

The SEND-STD-TRK-GRP-URI token is used to indicate if the trunk group parameters defined by draft-ietf-iptell-trunk-group should be used when an invite request and the trunk_sub_grp_type field is set to TGID. The default value is N.

Softswitch Trunk Group Profile

The Softswitch Trunk Group Profile (softsw-tg-profile) table holds all the information specific to a Softswitch trunk, such as ID, protocol, indicators and echo suppression. The softsw-tg-profile record can be shared by multiple softswitch trunk groups. An ID must be created in this table before entries can be added to the Trunk Group table. For token names and description details for the Trunk Group Profile table, refer to the [Cisco BTS 10200 Softswitch CLI Database](#).

SIP-INBOUND-POLICY-PROFILE Table

The SIP-INBOUND-POLICY-PROFILE table has two new POLICY-TYPE values: CONTACT-TGRP and CONTACT-TRUNK-CONTEXT. The Action field is also split into two different files: MISSING-ACTION and NOMATCH-ACTION.

SIP Inbound Policy Profile

The SIP Inbound Policy Profile (sip-inbound-policy-profile) table determines the inbound trunk group based on various SIP headers and parameters. For token names and description details for the SIP Inbound Policy Profile table, refer to the [Cisco BTS 10200 Softswitch CLI Database](#).

On-Net Routing and LNP for Inter-CMS Routing

On-Net Routing and LNP for Inter-CMS routing provide the following capabilities:

- ANSI LNP Query Support for Carrier Calls—Conditionally allow LNP queries on carrier calls, as determined by the Carrier LNP-QUERY flag
- LNP Query for On-net Routing, Inter CMS Routing—Provide control of LNP queries based on the dialed digit-string prefix and Destination. The operator can allow or deny LNP queries for different calls and routing scenarios. For example, queries should be unconditionally blocked for some CMS originations, and for some MGC cases queries should be performed. When a Cisco BTS 10200 is acting as both CMS and MGC, the query should be prevented on the subscriber origination towards the NRS, but performed when a call terminates to the MGC on a SIP or PSTN trunk. For traditional Cisco BTS 10200 on-net routing scenarios, a query might be desired on subscriber originations to DNs potentially on the same switch (SUB-ONLY), or on other on-net switches (ALL-CALLS).
- On-net Route Bypass of Carrier Route—For interLATA or toll calls, allow an on-net route, as defined in the Destination table, to override the carrier routing. On-net refers to facilities owned by an operator which includes one or more Cisco BTS 10200 switches (or other switches). SUB-ONLY allows carrier bypass to route the call to a local subscriber on the same Cisco BTS 10200. ALL-CALLS allows carrier bypass for all calls which have a valid on-net route. LNP query results are taken into account in the routing decision.
- Remove LNP Query result data when Carrier LNP-QUERY= N—For an outgoing carrier call with Carrier LNP-QUERY=N, remove the LNP query result data, if present. The LRN, FCI, and GAP are destroyed as if a query were not performed.
- Ignore Inbound LNP information—For an incoming trunk call with LNP data including forward call indicators, and so forth. When forward call indicators (FCI) bit-M indication "number translated" and Location Routing Number (LRN) and Generic Address Parameter (GAP) are included, the LNP data is ignored, resulting in call delivery based on the called DN (from the GAP).

On-Net Routing

Figure 2-13 shows On-net Routing in a multiple Cisco BTS 10200 environment for ALL-CALLS. The goal for the operator is to route all calls within the operator's network which will eventually terminate within the operator's network. That is, carrier routing is bypassed in favor of the on-net route. So, the Destination BYPASS-CARRIER-ROUTING is set to ALL-CALLS. In this scenario, LNP queries are performed on the originating switch (if ported office code and other criteria indicate a query should be performed). Therefore, the destination NANP-LNP-QUERY value PERFORM-LNP-QUERY is used.

Figure 2-13 On-net Routing ALL-CALLS Scenarios

On-net Routing in Multi-BTS Environment: ALL-CALLS A calls B*

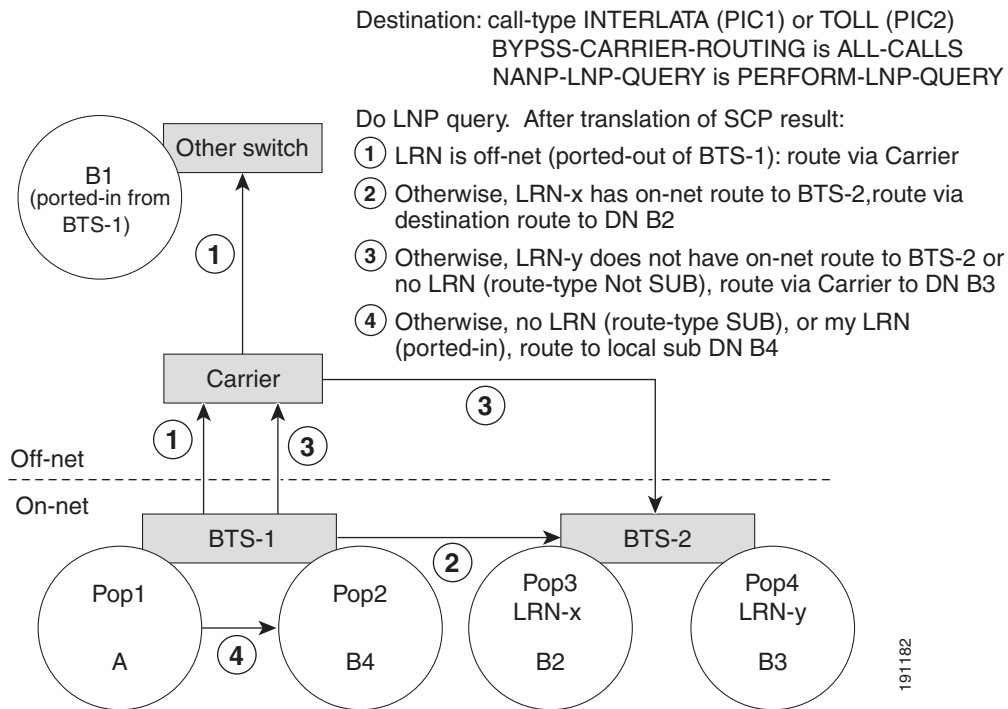

Figure 2-14 shows on-net routing in a multiple Cisco BTS 10200 environment for calls which terminate in the same Cisco BTS 10200 that originated the call, for which no LNP query is needed. That is, the operator can avoid carrier routing for calls that terminate on the same switch. For this scenario, the operator is willing to make a trade-off for DNs during the porting transition. That is, in order to avoid extra LNP queries, any DN in the porting transition phase (marked Dn2subscriber status ASSIGNED and LNP-TRIGGER=Y) is routed to the carrier. The carrier performs the LNP query, and if necessary, routes the call back. The trade-off is fewer LNP queries versus unnecessary carrier routing in some cases.

191182

Figure 2-14 On-net Routing SUB-ONLY (Not Ported Subs Only) Scenarios

On-net Routing: SUB-ONLY (not ported subs only) A calls B*

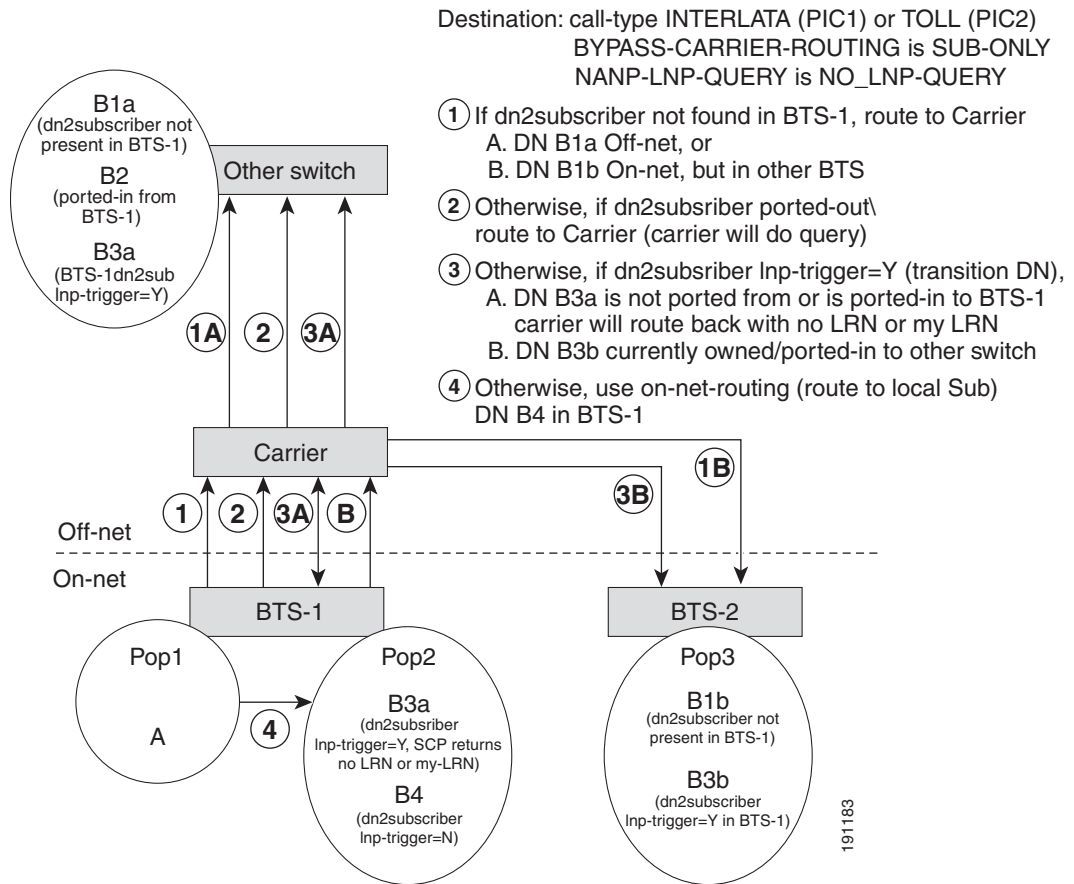
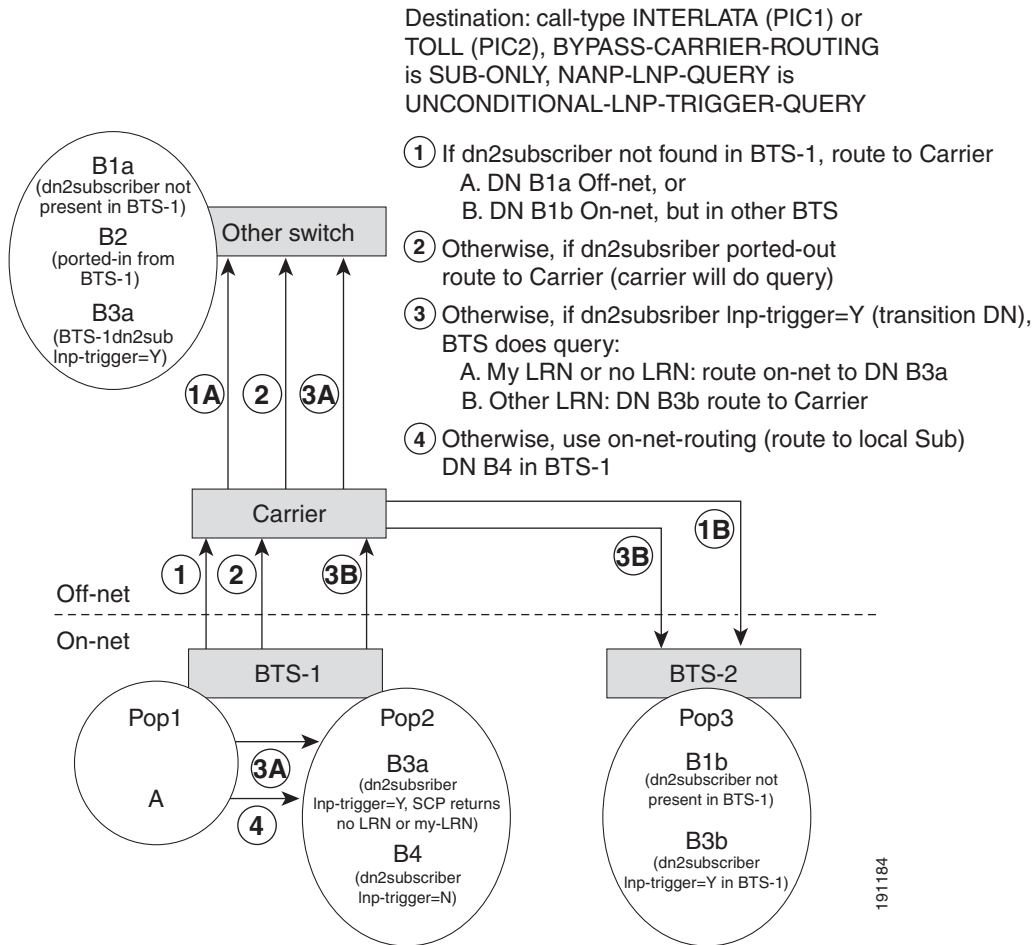

Figure 2-15 shows on-net routing in a multiple Cisco BTS 10200 environment for calls which terminate in the same Cisco BTS 10200 that originated the call, for which the originating Cisco BTS 10200 does an LNP query for transition DNs. The operator can avoid carrier routing for calls that terminate on the same switch. In this case, the operator is willing to accept additional LNP queries to be sure to avoid carrier routing for all cases of local subscribers. For any carrier call to the DN which is in the porting transition on this switch (Dn2subscriber status assigned and LNP-TRIGGER=Y), an LNP query is done. This is determined by the Destination NANP-LNP-QUERY UNCONDITIONAL-LNP-TRIGGER-QUERY value. After the query, the call is routed to the local subscriber, or to the carrier, depending on the query result.

Figure 2-15 On-net Routing SUB-ONLY (Cisco BTS 10200 Queries for Transition Subs) Scenarios

On-net Routing: SUB-ONLY (BTS queries for transition subs) A calls B*



The above illustrations and descriptions give an overview of some of the LNP query and routing scenarios. For a detailed itemization of the various use cases, please see [Table 2-5 on page 2-44](#).

Inter-CMS Routing

Descriptions of all the possible configurations for inter-CMS routing are not included here. In principle, the scenarios shown in the “On-Net Routing” section on page 2-31 can be applied to an individual CMS or MGC in an inter-CMS configuration. An overview is provided below.

Figure 2-16 illustrates an inter-CMS configuration with an NRS and separated CMS and MGC. CMS refers to a PacketCable Cable Management Server, which serves cable subscribers. The MGC refers to the Media Gateway Controller, which in PacketCable terminology refers to the node that interfaces with the PSTN. An MGC can also serve as the PSTN interface for SIP endpoints behind an NRS and Service Engine (SE), and Edge Proxy (EP).

The originating CMS, for example, CMS-1, routes the call to the NRS without an LNP query. So subscriber dial plans on CMS-1 will have destinations for which NANP-LNP-QUERY is NO-LNP-QUERY. The NRS can then route the call to either the MGC or CMS-2. MGC and CMS-2 incoming trunk dial plans might have destinations which allow LNP queries. So these destinations may have NANP-LNP-QUERY values of NA or PERFORM-LNP-QUERY.

191184

Figure 2-16 Inter-CMS Routing: Separated CMS/MGC

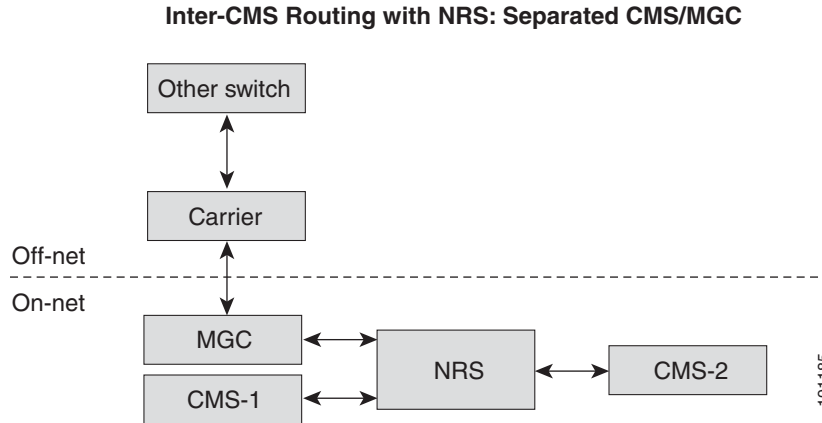

Figure 2-17 illustrates an inter-CMS configuration with an NRS and a single Cisco BTS 10200 acting as both a CMS and MGC. In principle, there is nothing different from the instance above where the CMS and MGC are separated. But this configuration drove the requirement to control LNP queries by the NANP-LNP-QUERY field based on subscriber dial plan separately from trunk dial plans on a per destination basis.

Figure 2-17 Inter-CMS Routing: CMS and MGC on Same Cisco BTS 10200

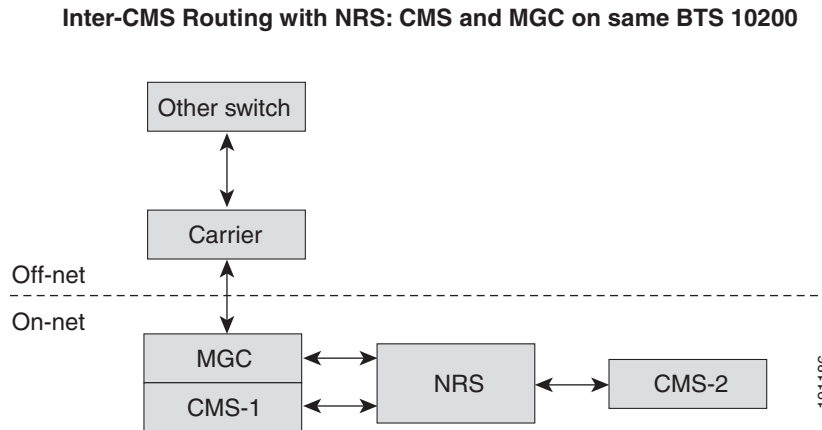

Table 2-4 shows destination NANP-LNP-QUERY and BYPASS-CARRIER-ROUTING settings for the various configurations.

ANSI LNP Query Support for Carrier Calls

LNP queries are now to be conditionally allowed on interLATA and intraLATA (toll) carrier calls. When carrier routing applies (for either casual dialing, or presubscribed Preferred Interexchange Carrier (PIC), Carrier LNP-QUERY=Y/N is used to indicate whether an LNP query is allowed. This capability exists for ITU LNP, and is added for ANSI/North America.



Note

LNP query capability is supported for interLATA (PIC1) and toll (PIC2) calls; however, queries are not supported in international (call-type INTL, PIC3) calls, because number portability is not supported for international calls.

For an interLATA/toll or casual carrier call, there is an interaction of the carrier LNP-QUERY flag and the NANP-LNP-QUERY flag:

- Carrier LNP-QUERY is applicable only when Carrier USE-DIAL-PLAN=N
- Carrier LNP-QUERY is applicable only when Destination NANP-LNP-QUERY=NA. When NANP-LNP-QUERY=NA:
 - If Carrier LNP-QUERY=N, then there is no query.
 - If Carrier LNP-QUERY=Y and NANP-LNP-QUERY value NA, then there may be a query depending on Ported Office Code and other criteria. For example, if a Ported Office Match is not found, or Dn2subscriber data criteria do not allow a query, then there is no query.
 - If both Carrier LNP-QUERY=Y, and NANP-LNP-QUERY criteria allow a query, then there is a query.

Within the LNP query criteria decision checks, carrier routing is detected by any of the following conditions:

- Presence of a Carrier Identification Code (CIC), for example as a result of casual dialing, or from ISUP Transit Network Selection (TNS) parameter.
- Call-type TOLL, appropriate Nature of Dial (NOD) value and origination with valid subscriber data PIC2 Call-type interLATA, appropriate Nature of Dial (NOD) value and origination with valid subscriber data PIC1

After any of the above checks for a valid carrier are satisfied, if the carrier database record has USE-DIAL-PLAN=Y, then by default the route from the destination is used, rather than routing specified in the carrier record. USE-DIAL-PLAN=Y implies that the Cisco BTS 10200 operator is itself the acting carrier for the call.

So, for carrier USE-DIAL-PLAN=Y, the normal LNP query decision criteria are used. For example, according to the preexisting LNP criteria logic, queries are still not allowed on a carrier call when any of the following apply:

- Operator (carrier) call
- When a ported-office-code match is not found
- When a dn2subscriber record is not found and the destination route-type is SUB
- When dn2subscriber status is not PORTED-OUT and LNP-TRIGGER=N

Otherwise, when Carrier LNP-QUERY=Y and USE-DIAL-PLAN=N, existing LNP query criteria allow queries on carrier calls when a ported-office-code match is found, and any of the following are true:

- Called DN does not appear in the office-code table.
- dn2subscriber entry for the DN is not found and either destination entry is not found or destination ROUTE-TYPE is not SUB.
- Dn2subscriber entry has status PORTED-OUT, or LNP-TRIGGER=Y.

LNP Query for On-net Routing, Inter-CMS Routing

LNP and ported-in and ported-out subscribers must be taken into account for Cisco BTS 10200 On-net Routing, inter-CMS Routing. This requirement provides precise control of LNP queries based on the dialed digit-string prefix and destination. The operator is given flexibility to allow or deny LNP queries for different calls and routing scenarios.

A new Destination schema field, NANP-LNP-QUERY is added with the following values:

- NA: support preexisting Cisco BTS 10200 LNP query capability (Release 4.5), with two additions:
 - Conditionally allow LNP queries on Carrier calls, in conjunction with the Carrier LNP-QUERY field.
 - Queries are now allowed on World Zone 1 calls (to Canada, Hawaii, Alaska, and so forth), that is, when call-type is INTL-WZ1.
- NO-LNP-QUERY: unconditionally prevents an LNP query on any call reaching this destination. This is useful for inter-CMS routing, or for any case where the originating CMS subscriber dial-plan prevents queries (because the query is performed by the NRS, MGC, terminating CMS, or Carrier).
- PERFORM-LNP-QUERY: Similar to NA value, except that the Carrier LNP-QUERY field is ignored, and a query can be allowed on any call-type. Prior to Release 5.0, the Cisco BTS 10200 allowed queries only for call-type local, interLATA, or toll. This value can be used in an on-net routing or inter-CMS scenario where a given CMS/MGC should perform LNP queries, especially prior to on-net routing.
- UNCONDITIONAL-LNP-TRIGGER-QUERY: Conditionally allows an LNP query for DN's during the porting in or out transition (Dn2subscriber LNP-TRIGGER=Y). This value is useful for an on-net routing scenario where carrier bypass is allowed for DN's assigned on the originating Cisco BTS 10200 (BYPASS-CARRIER-ROUTING SUB-ONLY). This value allows a query regardless of the call type.

Table 2-4 shows routing scenarios and suggested provisioning values.

Table 2-4 Routing Scenarios and Provisioning

Scenario	BYPASS-CARRIER-ROUTING	NANP-LNP-QUERY	Carrier LNP-QUERY
Normal - like Release 4.5.	NONE	—	N
Like Release 4.5, but queries are also to be allowed depending on the Carrier LNP-QUERY value.	NONE	—	Y
Carrier bypass (on-net route) only for local calls terminating on this switch which don't need an LNP query.	SUB-ONLY	NO-LNP-QUERY. but routing logic must route to carrier for PORTED-OUT and LNP-TRIGGER=Y cases.	—
Carrier bypass (on-net route) only for local calls terminating on this switch with queries allowed for DN's during porting transition.	SUB-ONLY	UNCONDITIONAL-LNP-TRIGGER-QUERY	—
Multi-Cisco BTS 10200—Carrier bypass (on-net route) to all on-net switches.	ALL-CALLS	PERFORM-LNP-QUERY	—
Inter-CMS no NRS.	ALL-CALLS	PERFORM-LNP-QUERY	—
Inter-CMS with NRS.	SUB-ONLY	UNCONDITIONAL-LNP-TRIGGER-QUERY	—

For more examples of provisioning combinations, and LNP query results and routing results, see Table 2-5.

Carrier Calls

See the “[On-net Route Bypass of Carrier Route](#)” section on page 2-40 and Destination NANP-LNP-QUERY value NA below.

Destination NANP-LNP-QUERY value NA:

This value is similar to previous Release 5.0 LNP query criteria, except that a query can be allowed for carrier calls. For value NA, there will be an LNP query if the following conditions are satisfied:

- An LNP query has not been done already by this Cisco BTS 10200 or another switch on the call.
- “Nature of Dial” (derived from nature of address), is one of the following:
 - 7-digit National, 10-digit National, 7-digit Local, 10-digit National, Casual-7-digit National, Casual 10-digit National, Casual 7-digit Local, Casual 10-digit Local, Network Specific 1, Network Specific 2, Network Specific 3, Network Specific 4, Network Specific 5, Network Specific 6, or Network Specific 7.
- Destination call-type:
 - Value is either local, interLATA, toll, toll-free, or INTL-WZ1.
 - Or, for a different call-type value, a matching entry is found in the Call Type Profile with LNP-QUERY=Y.
- If Carrier Identification Code (CIC) is present, and one of the following is true:
 - Carrier USE-DIAL-PLAN=Y, or Carrier LNP-QUERY=Y
 - Or, call-type toll,
 - The subscriber's Pop supports intraLATA toll pre-subscription (ITP=Y), and either PIC2 Carrier USE-DIAL-PLAN=Y or Carrier LNP-QUERY=Y,
 - Or, if the subscriber's Pop does not support intraLATA toll pre-subscription (ITP=N), then the Destination has route-type carrier, then if Carrier USE-DIAL-PLAN=Y, or Carrier LNP-QUERY=Y
 - Or call-type interLATA
- If PIC1 Carrier USE-DIAL-PLAN=Y, or Carrier LNP-QUERY=Y.
- Ported Office Code match found on 10-, 9-, 8-, 7-, 6-, or 3-digit prefix (longest match), and either:
 - Or Dn2subscriber record found and status is PORTED-OUT, or LNP-TRIGGER=Y
 - Or Dn2subscriber record not found, and either
 - Destination not found (this case might not actually be possible).
 - Or Destination route-type is not SUB.

Destination NANP-LNP-QUERY Value NO-LNP-QUERY

When digit translation results in reaching a destination with value NO-LNP-QUERY, then there is no LNP query in any case.

Destination NANP-LNP-QUERY Value PERFORM-LNP-QUERY

This value works exactly the same as value NA, except for these exceptions:

- PERFORM-LNP-QUERY allows a query on any call-type (rather than just for call-types local, interLATA, toll, and toll-free as for NA). The Call Type Profile is not checked.
- For carrier calls, PERFORM-LNP-QUERY allows a query without checking the Carrier LNP-QUERY value. So, even if LNP-QUERY=N, a query can be performed.

Destination NANP-LNP-QUERY Value UNCONDITIONAL-LNP-TRIGGER-QUERY

For value UNCONDITIONAL-LNP-TRIGGER-QUERY, there will be an LNP query if the following conditions are satisfied:

- An LNP query has not been done already by this Cisco BTS 10200 or another switch on the call.
- Nature of Dial (derived from nature of address), is one of the following:
 - 7-digit National, 10-digit National, 7-digit Local, 10-digit National, Casual 7-digit National, Casual 10-digit National, Casual 7-digit Local, Casual 10-digit Local, Network Specific 1, Network Specific 2, Network Specific 3, Network Specific 4, Network Specific 5, Network Specific 6, Network Specific 7
- Dn2subscriber record is found, and status is assigned, and LNP-TRIGGER=Y.

Retranslation After an LNP Query

After an LNP query, there might be a new translation based on the SCP result. Routing scenarios after an LNP query result are as follows:

- SCP returns no LRN: in this case, the original translation applies, and the call is routed appropriately.
- SCP returns an LRN:
 - LRN is off-net: the call is routed to the appropriate switch, by means of the routing specified by the new Destination reached through translation, and if applicable, the Carrier.
 - LRN is my LRN and carrier routing not applicable: The LRN is considered to be my LRN if either the LRN digits have a Dn2subscriber record with STATUS=LRN, or the calling party's POP contains MY-LRN digits which match the LRN from the SCP. In either case, the original called party digits (from GAP parameter received from the AIN Feature Server) are used to find the dn2subscriber entry, and the call is routed to the subscriber. This is also the case when the Destination has route-type not SUB; the Destination routing is overridden and the call is offered to the subscriber on the Cisco BTS 10200.
 - For a carrier call for which there is an on-net route and the LRN is on-net:
 - My LRN and the Dn2subscriber record exist with status assigned (LNP-TRIGGER=Y): route to the local subscriber, and ignore (bypass) carrier routing, and ignore the routing specified in the original Destination.
 - On-net LRN of another on-net switch: bypass carrier routing, and use the on-net route specified in the destination.

Call-type After Multiple Digit Translations

Normally after a digit translation, the call-type is retrieved from the resulting destination. It is possible that further digit translations will occur, for example, the retranslation on the LRN after an LNP query. Normally the call-type from the original translation is used after subsequent translations. So the call-type in the destination resulting from the LRN translation is ignored, in favor of the original call-type resulting from the original called DN translation.

An exception is that the call-type can change from a translation for policy-nxx. For example, dialed digits 611 translate to a destination with call-type repair, which has a route-guide containing policy-type=NXX, with a policy-nxx containing a new translated-dn. In this case, a new translation on the translated-dn occurs, and the new destination call-type is used subsequently during the call. This is necessary to prevent problems related to a possible NXX (800 toll-free) translation.

On-net routing is not supported for ITU LNP.

Removal of Ported Office Code IN-CALL-AGENT Field

As part of this feature, all checking of the Ported Office Code IN-CALL-AGENT flag is removed. Essentially within all logic for which there is a Ported Office Code match, the logic functions as if the IN-CALL-AGENT=Y.

Non-carrier call Routing to Ported-in DNs

Prior to Release 5.0, implicit routing was allowed for calls to ported-in subscribers. The DN of a ported-in subscriber is owned by another switch, so the dial-plan for the DN prefix goes to a destination which has a route to the donor switch (owning the DN block). During the Cisco BTS 10200 routing and translation, prior to routing using the destination route to the donor switch, if it is determined that the DN is for an assigned subscriber in the Cisco BTS 10200, and the DN or prefix has a Ported Office Code match, then the destination route is ignored, and the call is routed directly to the local subscriber.

In Release 5.0, the above routing logic is still applicable for destination NANP-LNP-QUERY values NA, PERFORM-LNP-QUERY, and UNCONDITIONAL-LNP-TRIGGER-QUERY.

However, destination NANP-LNP-QUERY value NO-LNP-QUERY has been added to block queries for network configurations where it is desirable for all CMS originations to route to an NRS. For such a configuration, the operator might want the explicit route from the dial plan and destination to be honored, even for ported-in subscribers. With this in mind, specifically for cases where the destination specifies NO-LNP-QUERY and the route-type is not SUB, the call is routed via the destination. This is the case for calls which do not have call-type interLATA or toll; for interLATA and toll carrier calls, the Destination BYPASS-CARRIER-ROUTING field determines whether carrier routing (value none) or routing to the local subscriber is desired (value SUB-ONLY or ALL-CALLS).

On-net Route Bypass of Carrier Route

Provide the capability to selectively override, or bypass, carrier routing if an on-net route exists to a subscriber on the same switch, or on another on-net switch within the same operator's network.

Specifically, for interLATA and intraLATA calls, that is, calls with destination call-type of interLATA or TOLL, carrier routing is normally bypassed in favor of the destination routing when:

- Destination BYPASS-CARRIER-ROUTING is ALL-CALLS, or
- Destination BYPASS-CARRIER-ROUTING is SUB-ONLY and a dn2subscriber record exists.

In addition to carrier bypass for the above scenarios, under certain conditions, carrier routing is allowed instead of routing to a local subscriber. For example, even if the subscriber appears to be ported-in to the CMS (Destination `BYPASS-CARRIER-ROUTING=NONE` and `ROUTE-TYPE` not `SUB`, `dn2subscriber STATUS=ASSIGNED` and `LNP-TRIGGER=Y`, and the query result contains my LRN of the same Cisco BTS 10200), carrier routing is used instead of routing directly to the local subscriber.

The operator owning the Cisco BTS 10200 may itself be a carrier, as defined by a carrier route with `Carrier USE-DIAL-PLAN=Y`. Essentially this is the same as On-net Routing, because the dial plan and destination routing are used for the call. Checks for On-net Routing carrier bypass only apply for carriers which do not use the dial plan routing (`USE-DIAL-PLAN=N`).

On-net routing does not apply to operator calls, and is also not supported for casual carrier calls.

Some sample values of the new `Destination BYPASS-CARRIER-ROUTING` field are shown in [Table 2-4](#).

Carrier Bypass in favor of an On-net Route applies under the following conditions:

- A PIC1 or PIC2 Carrier Identification Code (CIC) is present.
- Destination call-type is `interLATA` or `toll`.
- It is not an operator call.
- `Carrier USE-DIAL-PLAN=N` (see description of this below).
- Destination route-type is not carrier.
- It is not a casual carrier call (based on Nature of Dial, `NOD`).
- `Dn2subscriber` record for the DN does not exist, and the `Destination BYPASS-CARRIER-ROUTING` is `ALL-CALLS`.
- `Dn2subscriber` record exists, `BYPASS-CARRIER-ROUTING` is `SUB-ONLY` or `ALL-CALLS`, and any of the following is true:
 - `Dn2subscriber` status is `PORTED-OUT` and an LNP query was done. This condition implies that the SCP either returned no LRN, or my LRN (LRN matching either `Dn2subscriber` record with status `LRN`, or `Pop MY-LRN`). This is an error case, because the switch has marked the subscriber as `PORTED-OUT`, but the SCP has returned my LRN. There is no chance to complete this call, so we bypass carrier and route on-net, and the call fails. During the porting transition, our Cisco BTS 10200 has probably already marked the DN as ported-out, but the SCP has not updated the database with the correct LRN of the recipient switch.
 - `Dn2subscriber` status assigned, and `LNP-TRIGGER=N`: this is the normal case for carrier bypass to an on-net subscriber of this switch, for which LNP porting has not occurred.
 - `Dn2subscriber` status assigned, `LNP-TRIGGER=Y`, LNP query was done, route-type is `SUB` (donor transition case): We bypass carrier and route on-net, because our subscriber is in transition to being ported-out, but the SCP does not yet have the LRN of the recipient switch.
 - `Dn2subscriber` status assigned, `LNP-TRIGGER=Y`, LNP query was done, and route-type is `Not SUB`, and the SCP returned my LRN (recipient transition case): We bypass carrier and route on-net, because this DN is in transition to being ported-in to this switch, and the SCP has provided our LRN, indicating that the porting-in transition is complete.



Note

If the SCP query results in no LRN provided, it must assume that the porting-in transition has not completed, so we do not bypass carrier, because carrier routing is required to route the call to the switch owning the DN block range of the called DN.

- Dn2subscriber status not PORTED-OUT and not assigned, LNP query was done, and route-type is SUB: There is no chance to route this call. Because route-type is SUB, we know the DN's DN block (for example, NPA-NXX) is owned by this switch. Perhaps somebody has dialed a disconnected or vacant number, or accidentally dialed LRN. In any case, we bypass the carrier and route locally for the call to fail.

In a few cases, we do not bypass carrier routing because a necessary LNP query was not done, or for other reasons we may not be able to correctly route the call. For example:

- Dn2subscriber record exists, BYPASS-CARRIER-ROUTING is SUB-ONLY or ALL-CALLS, Dn2subscriber status is PORTED-OUT, and an LNP query was not done. For status PORTED-OUT, an LNP query is needed to route the call. Probably there is a provisioning discrepancy, for example, in a switch with a ported-out DN, a destination which specifies BYPASS-CARRIER-ROUTING of either SUB-ONLY or ALL-CALLS should have the NANP-LNP-QUERY set to NA or PERFORM-LNP-QUERY. Also, the Ported Office Code might be missing. In any case, the carrier bypass without an LNP query prevents the call from completing to the DN on the recipient switch, so the call is routed to the carrier, who is expected to do the query and complete the call to the recipient switch.
- Dn2subscriber record exists, BYPASS-CARRIER-ROUTING is SUB-ONLY or ALL-CALLS, Dn2subscriber status is assigned, LNP-TRIGGER=Y, and an LNP query was not done. For status assigned with LNP-TRIGGER=Y, an LNP query is expected in order to determine whether the DN during the porting transition is still on our switch or not. Probably there is a provisioning discrepancy, for example, in a switch with a DN in porting transition, a Destination which specifies BYPASS-CARRIER-ROUTING of either SUB-ONLY or ALL-CALLS should have the NANP-LNP-QUERY set to NA, PERFORM-LNP-QUERY, or UNCONDITIONAL-LNP-TRIGGER-QUERY. Also, the Ported Office Code might be missing. In any case, the carrier bypass without an LNP query routes the call to the subscriber on this switch, which might be incorrect. So carrier bypass is not allowed, and we let the carrier take care of routing the call properly.
- Dn2subscriber record exists, BYPASS-CARRIER-ROUTING is SUB-ONLY or ALL-CALLS, Dn2subscriber status is not assigned, LNP-TRIGGER=N, and route-type is not SUB. This is an unusual case, because we have a dn2subscriber record, but the Destination route-type is Not SUB. Possibly a DN ported-in to this switch, but the DN has since been marked as vacant, disconnected, and so forth. Since the NPA-NXX DN block is not owned (implied by route-type not SUB), the carrier routing is allowed to route the call to the number block owner.

Remove LNP Query Result Data When Carrier LNP-QUERY= N

For an outgoing carrier call after an LNP query in the same switch, with Carrier LNP-QUERY=N, remove the LNP query result data, if present. The LRN, FCI, and GAP are destroyed as if a query were not performed. That is, the outgoing IAM Forward Call Indicators (FCI) bit-M is set to not translated, and if Generic Address Parameter (GAP) is present, then the Called Party Number (CdPN) digits are set to the (ported) called DN from the Generic Address Parameter (GAP). Additionally, the GAP parameter is destroyed.

Existing Cisco BTS 10200 operators might have agreements with their carriers that the carrier does the LNP query. Before this feature was introduced, the Cisco BTS 10200 did not allow an LNP query on carrier calls. Now, as a result of this feature, LNP queries might be required in order to determine whether an on-net route exists. If a query is needed but then it is determined that the call needs to be routed to the carrier, and the carrier expects to perform queries (Carrier LNP-QUERY=N), the LNP data is removed. This ensures that the carrier's expectation that it can do the query is met, and the carrier is not aware that a query was already done.

The LNP data is removed only if the LNP query occurred on the same switch. This ensures that valid LNP data as a result of a query that was done by any switch prior to routing to this Cisco BTS 10200 is not removed.

Removing the LNP data affects only the outgoing signaling message (that is, SS7 ISUP IAM). The LNP data is retained in the Cisco BTS 10200, so billing and other functions are not affected by removal of the LNP data from the signaling message. The LNP data is removed if all of the following conditions are met:

- An ANSI LNP query was performed in this switch.
- The outgoing signaling message contains the Transit Network Selection (TNS) parameter, which has a Carrier Identification Code (Carrier ID, or CIC).
- Carrier record (accessed by Carrier ID from the TNS) has LNP-QUERY=N.
- Carrier record has USE-DIAL-PLAN=N.

Note that an alternative method to remove the LNP data is pre-existing. That is, if the outgoing trunk group SIGNAL-PORTED-NUMBER=Y, then the LNP data is removed in the same way as described above.

Ignore Inbound LNP Information

When an incoming trunk call is received on a trunk group with IGNORE-INBOUND-LNP=Y, ignore any received LNP data as if it were not received. Specifically, the FCI bit-M is set to “number not translated.” and if the GAP and LRN are present, the GAP digit string is inserted in the Called Party Number digit string, and the GAP and LRN are destroyed.

The LNP data received on an incoming call as the result of an LNP query on another switch might consist of:

- ANSI ISUP forward call indicators (FCI) bit-M set indicating "translated number", and is present if an LNP query was performed.
- LRN and GAP are present if provided by the SCP as a result of an LNP query when the DN is ported; LRN and GAP are not present if the DN is not ported:
 - The Generic Address Parameter (GAP) might contain the original called party digits (GAP type of address indicates ported dialed number), and
 - The Called Party Number (CdPN) parameter might contain the Location Routing Number (LRN) which addresses the recipient switch.

This requirement adds the capability to let the LNP information be ignored and process the call as if the called party digits were dialed without an LNP query.

When a call is received on a trunk group and the trunk group IGNORE-INBOUND-LNP=Y, and if the FCI indicates translated number and a GAP is present, then the GAP (original called party) digits are copied into the CdPN digits (destroying the LRN). The GAP parameter is then destroyed and the FCI is reset to indicate that the number is not translated. Then the call is allowed to proceed.

Note that this requirement has the following side effects on other existing LNP functionality:

1. The billing record does not show the LRN and GAP.
2. If the call fails and LNP-specific measurements and notifications are not received, the system performs as if the LRN and GAP were not received.



IGNORE-INBOUND-LNP=Y should be used with care, and is not recommended for normal routing scenarios. Clearing the FCI could minimally result in extra, unneeded queries, and at worst, result in routing loops during porting transitions. For example, if a DN is ported twice, and different switches/operators use different SCPs, which don't have LRNs exactly synchronized, then each switch will query their SCP and route the call to the other. Such a routing loop ("shoelaces") would continue until one of the hops expires or all available trunks are exhausted. Once the hop count expires or all trunks are seized, then everything immediately clears. Nevertheless, such routing loops are a reason for concern, and the normal FCI checks with IGNORE-INBOUND-LNP=N will prevent them from occurring.

If IGNORE-INBOUND-LNP=Y is used, we recommend that you tailor the appropriate trunk group profile(s) (for example, ss7-ansi-tg-profile) hop-counter to a reasonable (small) value such that a routing loop, should it occur, does not busy out too many trunk circuits.

On-net Routing Use Case Matrix

Table 2-5 provides a matrix of on-net routing use cases.

Table 2-5 On-net Routing Use Case Matrix

Use Case No.	NANP-LNP-QUERY	Carrier Call? (InterLATA or Toll, use-dial-plan=N)	Carrier LNP-QUERY	BYPASS-CARRIER	Ported-Office-Code Match?	LNP-TRIGGER or PORTED-OUT?	LNP Query?	LNP Query LRN?	Action
1	NO-LNP-QUERY	N	DC ¹	DC	DC	DC	N		Normal call routing.
2	NO-LNP-QUERY	N	DC	DC	DC	Y	N		Normal call routing.
3	NO-LNP-QUERY	N	DC	DC	DC	Y	N		Normal call routing.
4	NO-LNP-QUERY	N	DC	DC	Y	N	N		Destination routing.
5	NO-LNP-QUERY	N	DC	DC	N	Y	N		Error case.
6	NO-LNP-QUERY	N	DC	DC	Y	Y	N		Destination routing.
7	NO-LNP-QUERY	Y	DC (N)	NONE	DC (Y)	N	N		Carrier routing.
8	NO-LNP-QUERY	Y	DC (Y)	NONE	DC (Y)	DC (N)	N		Carrier routing.
9	NO-LNP-QUERY	Y	DC (Y)	NONE	DC	DC (Y)	N		Carrier routing.

Table 2-5 On-net Routing Use Case Matrix (continued)

Use Case No.	NANP-LNP-QUERY	Carrier Call? (InterLATA or Toll, use-dial-plan=N)	Carrier LNP-QUERY	BYPASS-CARRIER	Ported-Office-Code Match?	LNP-TRIGGER or PORTED-OUT?	LNP Query?	LNP Query LRN?	Action
10	NO-LNP-QUERY	Y (PIC2)	DC (Y)	NONE	DC	DC (Y)	N		Carrier routing.
11	NO-LNP-QUERY	Y	DC (Y)	NONE	DC	DC (Y)	N		Carrier routing.
12	NO-LNP-QUERY	Y	DC (Y)	SUB-ONLY	Y	N	N		Carrier routing.
13	NO-LNP-QUERY	Y	DC (Y)	SUB-ONLY	Y	N	N		Bypass carrier and route on-net to local sub.
14	NO-LNP-QUERY	Y	DC (Y/N)	SUB-ONLY	Y	Y	N		Carrier routing.
15	NO-LNP-QUERY	Y	DC (Y/N)	SUB-ONLY	Y	Y	N		Carrier routing.
16	NO-LNP-QUERY	Y	DC (Y/N)	SUB-ONLY	Y	Y	N		Carrier routing.
17	NO-LNP-QUERY	Y	DC (Y)	ALL-CALLS	Y	N	N		Bypass carrier and route on-net to local sub.
18	NO-LNP-QUERY	Y	DC (Y/N)	ALL-CALLS	Y	Y	N		Bad provisioning.
19	NO-LNP-QUERY	Y	DC (Y/N)	ALL-CALLS	Y	Y	N		Bypass carrier.
101	—	N	DC	DC	Y	N	Y/N		Normal call routing.
102	—	N	DC	DC	Y	N	Y/N		Normal call routing.
103	—	N	DC	DC	Y	Y	Y	DC	Normal call routing.
100	—	N	DC (N)	DC	Y	Y	Y	Any LRN	Retranslate on received LRN.
100a	A ²	Local		DC				My LRN	Same destination after query.
100b	B ³	Local		DC				On-net LRN	Route on-net via LRN destination.
100c	C ⁴	Local		DC				Off-net LRN	Route via LRN destination.

Table 2-5 On-net Routing Use Case Matrix (continued)

Use Case No.	NANP-LNP-QUERY	Carrier Call? (InterLATA or Toll, use-dial-plan=N)	Carrier LNP-QUERY	BYPASS-CARRIER	Ported-Office-Code Match?	LNP-TRIGGER or PORTED-OUT?	LNP Query?	LNP Query LRN?	Action
104	—	Y	Y	NONE	Y	N	Y	No LRN	Carrier routing.
105	—	Y	Y	NONE	Y	Y	Y	No LRN	Carrier routing after LNP query
106	—	Y	Y	NONE	Y	Y	Y	Any LRN	Carrier allows LNP QUERY—retranslate on received LRN.
106a	A	Carrier		NONE				My LRN	Error case.
106b	B	Carrier		ALL-CALLS				On-net LRN	After LRN translation, make new routing decision based on new destination.
106c	C	Carrier		NONE OR SUB-ONLY				Off-net LRN	New destination after LRN translation. Route to Carrier.
107	—	Y	Y (PIC2)	NONE	Y	Y	Y	No LRN	Carrier routing after LNP query.
108	—	Y	Y	NONE	Y	Y	Y	Any LRN	Carrier allows LNP QUERY—retranslate on received LRN.
108a	A	Carrier		NONE				My LRN	Carrier routing.
108b	B	Carrier		ALL-CALLS				On-net LRN	New destination after LRN translation.
108c	C	Carrier		NONE OR SUB-ONLY				Off-net LRN	New destination after LRN translation.
109	—	Y	DC (Y)	SUB-ONLY	Y	N	N		Route on-net (carrier bypass) to local sub.

Table 2-5 On-net Routing Use Case Matrix (continued)

Use Case No.	NANP-LNP-QUERY	Carrier Call? (InterLATA or Toll, use-dial-plan=N)	Carrier LNP-QUERY	BYPASS-CARRIER	Ported-Office-Code Match?	LNP-TRIGGER or PORTED-OUT?	LNP Query?	LNP Query LRN?	Action
110	—	Y	DC (Y)	SUB-ONLY	N	N	N		Route on-net (carrier bypass) to local sub .
111a	—	Y	Y	SUB-ONLY	DC (Y)	N	N		Carrier routing.
111b	—	Y	N	SUB-ONLY	DC (Y)	N	N		Carrier routing.
111c	—	Y	Y	SUB-ONLY	DC (Y)	N	N		Carrier routing.
112	—	Y	Y	SUB-ONLY	Y	N	N		Carrier routing.
113	—	Y	Y	SUB-ONLY	Y	N	N		Carrier routing.
114	—	Y	Y	SUB-ONLY	Y	N	Y	No LRN	Carrier routing.
115	—	Y	N	SUB-ONLY	Y	Y	N		Carrier routing.
116	—	Y (PIC2)	N	SUB-ONLY	Y	Y	N		Carrier routing.
117	—	Y	Y	SUB-ONLY	Y	Y	Y	No LRN	Route on-net (carrier bypass).
118	—	Y (PIC2)	Y	SUB-ONLY	Y	Y	Y	No LRN	Route on-net (carrier bypass).
119	—	Y (PIC2)	Y	SUB-ONLY	Y	Y	Y	No LRN	Route to carrier.
120	—	Y	Y	SUB-ONLY	Y	Y	Y	Any LRN	Carrier allows LNP QUERY—retranslate on received LRN.
120a	A	Carrier		SUB-ONLY				My LRN	On-net route to local sub.
120b	B	Carrier		ALL-CALLS				On-net LRN	New destination after LRN translation.

Table 2-5 On-net Routing Use Case Matrix (continued)

Use Case No.	NANP-LNP-QUERY	Carrier Call? (InterLATA or Toll, use-dial-plan=N)	Carrier LNP-QUERY	BYPASS-CARRIER	Ported-Office-Code Match?	LNP-TRIGGER or PORTED-OUT?	LNP Query?	LNP Query LRN?	Action
120c	C	Carrier		NONE OR SUB-ONLY				Off-net LRN	New destination after LRN translation—carrier routing.
121	—	Y	Y	SUB-ONLY	Y	Y	Y	Any LRN	Carrier allows LNP QUERY—retranslate on received LRN.
121a	A	Carrier		SUB-ONLY				My LRN	Same destination after query.
121b	B	Carrier		ALL-CALLS				On-net LRN	New destination after LRN translation.
121c	C	Carrier		NONE or SUB-ONLY				Off-net LRN	New destination after LRN translation—carrier routing.
122	—	PIC1 or PIC2	Y	ALL-CALLS	N	N	N		On-net route (carrier bypass) to local sub.
123	—	PIC1 or PIC2	Y	ALL-CALLS	Y	N	N		On-net route (carrier bypass).
124	—	Y	N	ALL-CALLS	Y	Y	N		Bad provisioning.
125	—	Y (PIC2)	N	ALL-CALLS	Y	Y	N		Bad provisioning.
126	—	Y (PIC2)	N	ALL-CALLS	Y	Y	N		Bad provisioning.
127	—	Y	Y	ALL-CALLS	Y	Y	Y	No LRN	On-net routing to local sub.
128	—	Y (PIC2)	Y	ALL-CALLS	Y	Y	Y	No LRN	On-net routing to local sub.
129	—	Y (PIC2)	Y	ALL-CALLS	Y	Y	Y	No LRN	On-net routing (carrier bypass).

Table 2-5 On-net Routing Use Case Matrix (continued)

Use Case No.	NANP-LNP-QUERY	Carrier Call? (InterLATA or Toll, use-dial-plan=N)	Carrier LNP-QUERY	BYPASS-CARRIER	Ported-Office-Code Match?	LNP-TRIGGER or PORTED-OUT?	LNP Query?	LNP Query LRN?	Action
130	—	Y	Y	ALL-CALLS	Y	Y	Y	Any LRN	Carrier allows LNP QUERY—retranslate on received LRN.
130a	A	Carrier		ALL-CALLS				My LRN	Same destination after query.
130b	B	Carrier		ALL-CALLS				On-net LRN	New destination after LRN translation.
130c	C	Carrier		NONE or SUB-ONLY				Off-net LRN	New destination after LRN translation.
201	PERFORM-LNP-QUERY	N	DC (Y)	DC	Y	N	Y/N		Normal call routing.
202	PERFORM-LNP-QUERY	N	DC (N)	DC	Y	Y	Y	DC	Normal call routing.
203	PERFORM-LNP-QUERY	Y	DC (Y)	NONE	Y	N	N		Carrier routing.
204	PERFORM-LNP-QUERY	Y	DC (Y)	NONE	Y	N	N		Carrier routing.
205	PERFORM-LNP-QUERY	Y	DC (N)	NONE	Y	N	N		Carrier routing.
206	PERFORM-LNP-QUERY	Y	DC (N)	NONE	Y	Y	Y	No LRN	Carrier routing.
207	PERFORM-LNP-QUERY	Y	DC (N)	NONE	Y	Y	Y	Any LRN	Re-translate on received LRN.
207a	A	Carrier		NONE				My LRN	Error case.

Table 2-5 On-net Routing Use Case Matrix (continued)

Use Case No.	NANP-LNP-QUERY	Carrier Call? (InterLATA or Toll, use-dial-plan=N)	Carrier LNP-QUERY	BYPASS-CARRIER	Ported-Office-Code Match?	LNP-TRIGGER or PORTED-OUT?	LNP Query?	LNP Query LRN?	Action
207b	B	Carrier		ALL-CALLS				On-net LRN	After LRN translation, make new routing decision based on new destination.
207c	C	Carrier		NONE OR SUB-ONLY				Off-net LRN	Retranslate on LRN.
208	PERFORM-LNP-QUERY	Y	DC	NONE	Y	Y	Y	No LRN	On-net routing to local sub.
209	PERFORM-LNP-QUERY	Y	DC	NONE	Y	Y	Y	Any LRN	Carrier allows LNP QUERY—retranslate on received LRN.
209a	A	Carrier		NONE				My LRN	ERROR case.
209b	B	Carrier		ALL-CALLS				On-net LRN	After LRN translation, make new routing decision based on new destination.
209c	C	Carrier		NONE OR SUB-ONLY				Off-net LRN	Retranslate on LRN—after LRN translation, make new routing decision based on new destination.
210	PERFORM-LNP-QUERY	Y	DC	SUB-ONLY	N	N	N		Route on-net (carrier bypass) to local sub.
211	PERFORM-LNP-QUERY	Y	DC	SUB-ONLY	Y	N	N		Route on-net (carrier bypass) to local ported-in sub.

Table 2-5 On-net Routing Use Case Matrix (continued)

Use Case No.	NANP-LNP-QUERY	Carrier Call? (InterLATA or Toll, use-dial-plan=N)	Carrier LNP-QUERY	BYPASS-CARRIER	Ported-Office-Code Match?	LNP-TRIGGER or PORTED-OUT?	LNP Query?	LNP Query LRN?	Action
212	PERFORM-LNP-QUERY	Y	DC (N)	SUB-ONLY	Y	Y	Y	No LRN	On-net routing to local sub.
213	PERFORM-LNP-QUERY	Y	DC (N)	SUB-ONLY	Y	Y	Y	No LRN	Route on-net (carrier bypass) to local sub.
214	PERFORM-LNP-QUERY	Y	Y	SUB-ONLY	Y	Y	Y	Any LRN	Retranslate on received LRN.
214a	A	Carrier		SUB-ONLY				My LRN	Error case.
214b	B	Carrier		ALL-CALLS				On-net LRN	After LRN translation, make new routing decision based on new destination.
214c	C	Carrier		NONE OR SUB-ONLY				Off-net LRN	Retranslate on LRN—after LRN translation, make new routing decision based on new destination.
215	PERFORM-LNP-QUERY	Y	Y	SUB-ONLY	Y	Y	Y	Any LRN	Retranslate on received LRN.
215a	A	Carrier		SUB-ONLY				My LRN	Same destination after query.
215b	B	Carrier		ALL-CALLS				On-net LRN	After LRN translation, make new routing decision based on new destination.

Table 2-5 On-net Routing Use Case Matrix (continued)

Use Case No.	NANP-LNP-QUERY	Carrier Call? (InterLATA or Toll, use-dial-plan=N)	Carrier LNP-QUERY	BYPASS-CARRIER	Ported-Office-Code Match?	LNP-TRIGGER or PORTED-OUT?	LNP Query?	LNP Query LRN?	Action
215c	C	Carrier		NONE OR SUB-ONLY				Off-net LRN	Retranslate on LRN—after LRN translation, make new routing decision based on new destination.
216	PERFORM-LNP-QUERY	Y	DC (Y)	ALL-CALLS	N	N	N		On-net route (carrier bypass) to local sub.
217	PERFORM-LNP-QUERY	Y	DC (Y)	ALL-CALLS	N	N	N		Case 1: If dn2sub does exist, but is not assigned, route to the carrier. Case 2: If dn2sub does not exist, on-net route (carrier bypass), using route from destination.
218	PERFORM-LNP-QUERY	Y	DC (N)	ALL-CALLS	Y	Y	Y	No LRN	If dn2sub does exist, but is not assigned, route to the carrier.
219	PERFORM-LNP-QUERY	PIC1 or PIC2		ALL-CALLS	Y	Y	Y	Any LRN	Retranslate on received LRN.
219a	A	Carrier		SUB-ONLY				My LRN	Error case.
219b	B	Carrier		ALL-CALLS				On-net LRN	After LRN translation, make new routing decision based on new destination.

Table 2-5 On-net Routing Use Case Matrix (continued)

Use Case No.	NANP-LNP-QUERY	Carrier Call? (InterLATA or Toll, use-dial-plan=N)	Carrier LNP-QUERY	BYPASS-CARRIER	Ported-Office-Code Match?	LNP-TRIGGER or PORTED-OUT?	LNP Query?	LNP Query LRN?	Action
219c	C	Carrier		NONE OR SUB-ONLY				Off-net LRN	Retranslate on LRN—after LRN translation, make new routing decision based on new destination.
220	PERFORM-LNP-QUERY	Y		ALL-CALLS	Y	Y	Y	No LRN	On-net routing to local sub.
221	PERFORM-LNP-QUERY	Y		ALL-CALLS	Y	Y	Y	Any LRN	Retranslate on received LRN.
221a	A	Carrier		ALL-CALLS				My LRN	Error case.
221b	B	Carrier		ALL-CALLS				On-net LRN	After LRN translation, make new routing decision based on new destination.
221c	C	Carrier		NONE OR SUB-ONLY				Off-net LRN	Retranslate on LRN.
301	UNCONDITIONAL-LNP-TRIGGER-QUERY	N	DC	DC	Y	N	Y/N		Normal call routing.
302	UNCONDITIONAL-LNP-TRIGGER-QUERY	N	DC (Y)	DC	Y	Y	N		Normal call routing.

Table 2-5 On-net Routing Use Case Matrix (continued)

Use Case No.	NANP-LNP-QUERY	Carrier Call? (InterLATA or Toll, use-dial-plan=N)	Carrier LNP-QUERY	BYPASS-CARRIER	Ported-Office-Code Match?	LNP-TRIGGER or PORTED-OUT?	LNP Query?	LNP Query LRN?	Action
303	UNCONDITIONAL-LNP-TRIGGER-QUERY	N	DC	DC	Y	N	N		Route to local ported-in sub.
304	UNCONDITIONAL-LNP-TRIGGER-QUERY	N	DC (N)	DC	Y	Y	Y	No LRN	Normal call routing.
305	UNCONDITIONAL-LNP-TRIGGER-QUERY	N	DC (N)	DC (NONE)	Y	Y	Y	Any LRN	Retranslate on received LRN.
305a	A	Local		DC				My LRN	Route call to local ported-in sub.
305b	B	Local		DC				On-net LRN	Route via LRN destination.
305c	C	Local		DC				Off-net LRN	Route via LRN destination.
306	UNCONDITIONAL-LNP-TRIGGER-QUERY	Y	DC (Y)	NONE	Y	N	N		Carrier routing.
307	UNCONDITIONAL-LNP-TRIGGER-QUERY	Y	DC (Y)	NONE	Y	Y	Y	No LRN	Carrier routing.
308	UNCONDITIONAL-LNP-TRIGGER-QUERY	Y (Inter LATA)	DC (Y)	NONE	Y	Y	Y	Any LRN	Retranslate on received LRN.
308a	A	Carrier		NONE				My LRN	Carrier routing.

Table 2-5 On-net Routing Use Case Matrix (continued)

Use Case No.	NANP-LNP-QUERY	Carrier Call? (InterLATA or Toll, use-dial-plan=N)	Carrier LNP-QUERY	BYPASS-CARRIER	Ported-Office-Code Match?	LNP-TRIGGER or PORTED-OUT?	LNP Query?	LNP Query LRN?	Action
308b	B	Carrier		ALL-CALLS				On-net LRN	After LRN translation, make new routing decision based on new destination.
308c	C	Carrier		NONE or SUB-ONLY				Off-net LRN	After LRN translation, make new routing decision based on new destination.
309	UNCONDITIONAL-LNP-TRIGGER-QUERY	Y	DC (Y)	NONE	DC	Y	Y	No LRN	Carrier routing.
310	UNCONDITIONAL-LNP-TRIGGER-QUERY	Y	DC (Y)	NONE	DC	Y	Y	Any LRN	Retranslate on received LRN.
310a	A	Carrier		NONE				My LRN	Carrier routing.
310b	B	Carrier		ALL-CALLS				On-net LRN	After LRN translation, make new routing decision based on new destination.
310c	C	Carrier		NONE or SUB-ONLY				Off-net LRN	After LRN translation, make new routing decision based on new destination.

Table 2-5 On-net Routing Use Case Matrix (continued)

Use Case No.	NANP-LNP-QUERY	Carrier Call? (InterLATA or Toll, use-dial-plan=N)	Carrier LNP-QUERY	BYPASS-CARRIER	Ported-Office-Code Match?	LNP-TRIGGER or PORTED-OUT?	LNP Query?	LNP Query LRN?	Action
311	UNCONDITIONAL-LNP-TRIGGER-QUERY	Y	DC (Y)	SUB-ONLY	Y	N	N		Terminate call locally (bypass carrier) if my subscriber (status=assigned), otherwise normal carrier routing.
312	UNCONDITIONAL-LNP-TRIGGER-QUERY	Y	DC (Y)	SUB-ONLY	Y	Y	N		Normal carrier routing.
313	UNCONDITIONAL-LNP-TRIGGER-QUERY	Y (Inter LATA)	DC (Y)	SUB-ONLY	Y	Y	Y	no LRN	Bypass carrier; route on-net to local not ported (yet) subscriber.
314	UNCONDITIONAL-LNP-TRIGGER-QUERY	Y	DC (Y)	SUB-ONLY	Y	Y	Y	any LRN	Retranslate on received LRN.
314a	A	Carrier		SUB-ONLY				My LRN	Bypass carrier, and route on-net to not ported local sub.
314b	B	Carrier		ALL-CALLS				On-net LRN	After LRN translation, make new routing decision based on new destination.
314c	C	Carrier		NONE or SUB-ONLY				Off-net LRN	After LRN translation, make new routing decision based on new destination.

Table 2-5 On-net Routing Use Case Matrix (continued)

Use Case No.	NANP-LNP-QUERY	Carrier Call? (InterLATA or Toll, use-dial-plan=N)	Carrier LNP-QUERY	BYPASS-CARRIER	Ported-Office-Code Match?	LNP-TRIGGER or PORTED-OUT?	LNP Query?	LNP Query LRN?	Action
315	UNCONDITIONAL-LNP-TRIGGER-QUERY	Y	DC (Y/N)	SUB-ONLY	Y	Y	Y	No LRN	Normal carrier routing.
316	UNCONDITIONAL-LNP-TRIGGER-QUERY	Y	DC (Y)	SUB-ONLY	Y	Y	Y	Any LRN	Retranslate on received LRN.
316a	A	Carrier		SUB-ONLY				My LRN	Bypass carrier, and route on-net to ported in local sub.
316b	B	Carrier		ALL-CALLS				On-net LRN	After LRN translation, make new routing decision based on new destination.
316c	C	Carrier		NONE or SUB-ONLY				Off-net LRN	After LRN translation, make new routing decision based on new destination.
317	UNCONDITIONAL-LNP-TRIGGER-QUERY	Y	DC (Y)	ALL-CALLS	Y	N	N		Bypass carrier.
318	UNCONDITIONAL-LNP-TRIGGER-QUERY	Y	DC (Y/N)	ALL-CALLS	Y	Y	N		Bad provisioning.

Table 2-5 On-net Routing Use Case Matrix (continued)

Use Case No.	NANP-LNP-QUERY	Carrier Call? (InterLATA or Toll, use-dial-plan=N)	Carrier LNP-QUERY	BYPASS-CARRIER	Ported-Office-Code Match?	LNP-TRIGGER or PORTED-OUT?	LNP Query?	LNP Query LRN?	Action
319	UNCONDITIONAL-LNP-TRIGGER-QUERY	Y	DC (Y/N)	ALL-CALLS	Y	Y	Y	No LRN	Bypass carrier; route on-net to local not ported (yet) subscriber.
320	UNCONDITIONAL-LNP-TRIGGER-QUERY	Y	DC (Y/N)	ALL-CALLS	Y	Y	Y	No LRN	Bypass carrier; route on-net to switch owning the DN block.
321	UNCONDITIONAL-LNP-TRIGGER-QUERY	Y	DC (Y/N)	ALL-CALLS	Y	Y	Y	Any LRN	Retranslate on received LRN.
321a	A	Carrier		ALL-CALLS				My LRN	Bypass carrier, and route on-net to ported in local sub.
321b	B	Carrier		ALL-CALLS				On-net LRN	After LRN translation, make new routing decision based on new destination.
321c	C	Carrier		NONE or SUB-ONLY				Off-net LRN	After LRN translation, make new routing decision based on new destination.

1. DC: Don't care
2. A. (Result of Translated LRN)
3. B. (Result of Translated LRN)
4. C. (Result of Translated LRN)

Feature Interactions

There are no new, modified, or deleted feature interactions related to the Cisco BTS 10200 on-net routing and LNP for the Inter-CMS routing feature described in this document. In principle, it should not matter whether or not an LNP query or carrier bypass occurs on the forwarding leg of a forwarded call (for example, for CFU, CFB, and CFNA). Likewise, it should not matter whether the query is on a second leg of a multi-party call, such as for CT or TWC.

It is possible that an 8xx toll free service query and LNP query occur on the same call. For example, an 8xx number might be dialed which initially needs an 8xx query, and perhaps also an LNP query. The 8xx query is performed first, and then retranslation on the returned number (if present) occurs, and LNP checks are performed again, resulting in the following scenarios:

When the 8xx query returns a carrier and translated DN the carrier checks occur first:

- If the translated DN has a dial plan entry and destination, the LNP checks look at the carrier + translated DN, as applicable.
- If the translated DN does not have a dial plan entry and destination, the original destination is used during the LNP checks on carrier (if present) and translated DN.

Again, for the above scenarios, there is nothing different from normal LNP criteria checks. In the same way, the logic for checking the translated LRN, and for the carrier routing after the second translation.

Configuring

This section explains how to perform the following tasks:

- [Configuring LNP Queries](#)
- [Configuring an LNP Query on a Carrier Call](#)
- [Configuring Carrier Bypass \(On-net Route\)—No LNP Queries](#)
- [Configuring Carrier Bypass \(On-net Route\)—LNP Queries](#)
- [Configuring Carrier Bypass \(On-net Route\)—Multiple Cisco BTS 10200 Switches](#)
- [Configuring Inter-CMS—Subscriber Origination \(If No NRS\), or Trunk Origination on MGC or Terminating CMS \(ALL-CALLS + LNP Query\)](#)
- [Configuring Inter-CMS with NRS—Same Cisco BTS 10200 Acting as CMS and MGC](#)
- [Selectively Configuring LNP Queries \(Allow or Disallow\) for a Particular Call Type](#)

Configuring LNP Queries

For all destinations resulting from dial plan translations for which an LNP query is allowed, use the Destination NANP-LNP-QUERY default value NA. For all carrier entries, use LNP-QUERY default value N.

Specify the NANP-LNP-QUERY value either implicitly using the **add destination** command without specifying NANP-LNP-QUERY parameter, or explicitly set it.

For example:

```
change destination dest-id=local_call; nanp-lnp-query=NA;
```

Specify Carrier LNP-QUERY=N implicitly by omitting the LNP-QUERY parameter, or explicitly.

For example:

```
change carrier id=0333; lnp-query=N;
```

Configuring an LNP Query on a Carrier Call

For all destinations resulting from dial plan translations which could result in carrier routing (for example, destination call-type interLATA, toll, or carrier), the destination NANP-LNP-QUERY should have value PERFORM-LNP-QUERY or NA. If value NA is used, then the appropriate carrier entry should have either USE-DIAL-PLAN=Y or LNP-QUERY=Y.

For example either:

```
add destination dest-id=dest_carrier; call-type=interLATA; route-type=route;
route-guide-id=carrier_rg; nanp-lnp-query=PERFORM-LNP-QUERY; description=Allow LNP query
on Carrier calls;
```

Or:

```
add destination dest-id=dest_carrier; call-type=interLATA; route-type=route;
route-guide-id=carrier_rg; description=nanp-lnp-query has default value NA!;
```

```
add carrier id=0333; inter=Y; intra=Y; intl=Y; use-dial-plan=N; route-guide-id=dpc1-rg;
cut-thru=N; status=INS; lnp-query=Y; description=Allow an LNP query on calls to this
carrier;
```

```
add ported-office-code digit-string=703-484;
```

```
add dial-plan id=dp_nanp_sub; digit-string=703-484; min-digits=10; max-digits=10;
dest-id=dest_carrier;
```

Configuring Carrier Bypass (On-net Route)—No LNP Queries

The Cisco BTS 10200 will route a call to the carrier unless the called DN is a subscriber assigned on this switch and not in a porting transition state. For this scenario, the operator wants carrier bypass for local subscribers, but does not want to incur the overhead of LNP queries for DNs which are in the process of porting in or porting out (LNP-TRIGGER=Y). The operator might know that either A) there are no transition DNs in this switch (or perhaps all are ported-out), or B) there are very few, and the operator would prefer that the Carrier do the LNP query, and route calls back to our switch for a very few calls.

The destination has call-type interLATA for carrier routing, SUB-ONLY to allow carrier bypass for local subs, and NO-LNP-QUERY to force calls needing a query to go to the carrier.

For example:

```
add destination dest-id=carrier_or_sub; call-type=interLATA; route-type=SUB;
bypass-carrier-routing=SUB-ONLY; nanp-lnp-query=NO-LNP-QUERY; description=carrier route
unless SUB assigned (no query);
```

Configuring Carrier Bypass (On-net Route)—LNP Queries

The Cisco BTS 10200 routes this call to the carrier unless the called DN is a subscriber assigned on this switch. This includes DNs which are in the process of either porting in or porting out. For these transition DNs requiring an unconditional (ATIS document terminology), which are marked with Dn2subscriber LNP-TRIGGER=Y, the marked DNs will get an LNP query before the routing decision is made. For the transition DNs for which there is an LNP query, the LNP query results determine whether the call is routed to the carrier or bypasses the carrier if the subscriber is in this switch.

The destination has call-type interLATA for carrier routing, SUB-ONLY to allow carrier bypass for local subs, and UNCONDITIONAL-LNP-TRIGGER-QUERY to allow a query for DNs during the transition period.

For example:

```
add destination dest-id=carr_or_sub_lnp; call-type=interLATA; route-type=SUB;
bypass-carrier-routing=SUB-ONLY; nanp-lnp-query=UNCONDITIONAL-LNP-TRIGGER-QUERY;
description=Carrier unless local SUB (query DNs during porting transition);
```

To mark the DN 703-765-4449 number as a transition DN in the process of porting in or porting out:

```
change dn2subscriber office-code-index=1; dn=4449; lnp-trigger=Y;
```

Configuring Carrier Bypass (On-net Route)—Multiple Cisco BTS 10200 Switches

For an operator with multiple Cisco BTS 10200 switches that are all interconnected over an IP network, it is more efficient to route calls on-net and avoid routing a call to a carrier, which will only be routed back to another on-net switch. This is the scenario for which the On-net Routing feature was requested. However, to gain the advantage of all-IP on-net routing, there is the cost of additional LNP queries. LNP queries might be required before on-net routing to make sure that the called DN has not ported out of the network.

The Destination NANP-LNP-QUERY PERFORM-LNP-QUERY value is used to ensure that an LNP query is done before on-net routing. Of course, this query is still conditional, depending on whether the Ported Office Code entry exists and other related criteria. The destination call-type is either interLATA or toll, and the BYPASS-CARRIER-ROUTING value is ALL-CALLS. Three routing scenarios are possible:

1. Route to carrier for off-net call.
2. Route using destination for on-net call to another on-net switch.
3. Route on-net to subscriber in the same switch. Ignore carrier and destination routes.

For example:

```
add destination dest-id=carrier_or_bypass; call-type=interLATA; route-type=route;
route-guide-id=on_net_rg; nanp-lnp-query=PERFORM-LNP-QUERY;
bypass-carrier-routing=ALL-CALLS; description=LNP query, and route to carrier, or on-net;
```

Configuring Inter-CMS—Subscriber Origination (If No NRS), or Trunk Origination on MGC or Terminating CMS (ALL-CALLS + LNP Query)

There are various Inter-CMS scenarios where a Cisco BTS 10200, upon receiving an incoming trunk call, should perform an LNP query, and if an on-net route exists, bypass carrier routing. Or for an Inter-CMS network with no NRS, it might be desirable to do LNP queries on the originating CMS.

For example:

- MGC, acting as a PSTN gateway:
 - Call originated from a CMS, within the network—MGC can do an LNP query, and route either off-net or on-net.
 - Incoming call from the PSTN—Normally, the LNP query is done by the PSTN; however, if that does not happen, then the MGC can do an LNP query before routing the call within the network.
- Terminating CMS—A call originated on-net from a CMS can be routed directly to the terminating CMS, where perhaps an LNP query is needed.
- Originating CMS, for example, without NRS—It may be desirable to do an LNP query on the originating CMS, in order to route calls to a terminating CMS directly, and avoid routing through the MGC (or Carrier). In particular, doing the LNP query and on-net routing from the originating CMS can be helpful in an Inter-CMS network configuration without an NRS.

The provisioning for this scenario is exactly the same as for multiple Cisco BTS 10200 switches—Carrier bypass, above.

Configuring Inter-CMS with NRS—Same Cisco BTS 10200 Acting as CMS and MGC

Intermediate phases of inter-CMS routing can have a single Cisco BTS 10200 acting as the CMS for NCS subscribers, and also acting as an MGC PSTN interface. Essentially this is a combination of cases already shown above. For subscriber originations (CMS), the subscriber dial plans should not allow a query, and ensure that the call is routed on-net to the NRS (if applicable). Incoming trunk calls can be routed from the NRS to this Cisco BTS 10200 in case the final destination is a CMS subscriber or PSTN subscriber.

The key to understanding this configuration is realizing that for a subscriber origination, the subscriber dial plan will result in a Destination which does not allow an LNP query and may have an on-net route to the NRS. But for a trunk origination on the same Cisco BTS 10200, the incoming trunk dial plan, for the same DN, has a different destination, which will allow an LNP query, and will not bypass the Carrier for calls to the PSTN.

For example:

In the subscriber destination and dial plan; 703-484 is on-net and 301-444 is off-net.

- 703-484 may have DNs ported-out (needs queries).
- 301-444 (off-net) has no ported-in DNs Cisco BTS 10200, and does not need dial-plan entry (always carrier routing)

```
add destination dest-id=cms_sub_nrs; call-type=interLATA; route-type=route;
route-guide-id=nrs_rg; bypass-carrier-routing=ALL-CALLS; nanp-lnp-query=NO-LNP-QUERY;
description=Route all sub originations to NRS with no LNP query;
```

```
add dial-plan id=dp_nanp_sub; digit-string=703-484; min-digits=7; max-digits=10;
dest-id=cms_sub_nrs;
```

The incoming trunk group destination and dial plan:

```
add destination dest-id=carrier_or_bypass; call-type=interLATA; route-type=route;
route-guide-id=on_net_rg; nanp-lnp-query=PERFORM-LNP-QUERY;
bypass-carrier-routing=ALL-CALLS; description=LNP query, and route to carrier, or on-net;
```

```
add destination dest-id=dest_carrier; call-type=interLATA; route-type=route;
route-guide-id=on_net_rg; nanp-lnp-query=NO-LNP-QUERY; bypass-carrier-routing=ALL-CALLS;
description=Carrier will do LNP query;
```

```
add ported-office-code digit-string=703-484
```

```
add dial-plan id=dp_nanp_sub; digit-string=703-484; min-digits=7; max-digits=10;
dest-id=carrier_or_bypass;
```

```
add dial-plan id=dp_nanp_sub; digit-string=301-444; min-digits=7; max-digits=10;
dest-id=dest_carrier;
```

Selectively Configuring LNP Queries (Allow or Disallow) for a Particular Call Type

A Call Type Profile entry with LNP-QUERY=Y can be added to allow an LNP query for a particular call-type, for example, weather. However, by changing destination LNP criteria, it is possible to allow a query for some weather calls, but not others.

For example:

Allow a query on weather DN 703-569-2198

```
add call-type-profile call-type=weather; lnp-query=Y;

add destination dest-id=weather_query; call-type=weather; route-type=route;
route-guide-id=dpc2-rg; nanp-lnp-query=NA;

add dial-plan id=dp-1; digit-string=703-569-2198; min-digits=10; max-digits=10;
dest-id=weather_query;

add ported-office-code digit-string=703-569-2198;
```

Do not allow a query on weather DN 703-569-2197

```
add destination dest-id=weather_no_query; call-type=weather; route-type=route;
route-guide-id=dpc2-rg; nanp-lnp-query=NO-LNP-QUERY;

add dial-plan id=dp-1; digit-string=703-569-2197; min-digits=10; max-digits=10;
dest-id=weather_no_query;
```

Destination

The NANP-LNP-QUERY token used to define LNP criteria requirements for the USA. For complete Destination table details, refer to the [“Destination” section on page 1-24](#).

Carrier Existing LNP-QUERY=Y/N

When a LNP query was previously used for ITU LNP only and is now activated for ANSI, LNP query is allowed before routing outbound to a carrier, based on the Carrier LNP-QUERY value.

When the call is routed to the outbound carrier, if the Carrier LNP-QUERY=N, indicating that the carrier does not expect a query prior to carrier routing, but a query is done anyway on this switch, then the LNP information (LRN, FCI, and GAP) is destroyed.

Call Type Profile

The following items apply to an existing table for ITU LNP which is now activated for ANSI/North America LNP.

- Prior to this feature, an LNP query was allowed only for calltypes local, interLATA, toll, and toll-free. Now, for NANP-LNP-QUERY values PERFORM-LNP-QUERY and UNCONDITIONAL-LNP-TRIGGER-QUERY, a query can be performed for any call-type. For these NANP-LNP-QUERY values, the Call Type Profile is not checked.
- For NANP-LNP-QUERY value NA, a query is allowed for the existing call-types (local, interLATA, toll, and toll-free), and now also INTL-WZ1 (World Zone 1). However, it is possible now to selectively allow an LNP query for other call-types by adding a Call Type Profile entry for the call-type, and setting the Call Type Profile LNP-QUERY=Y. Of course, other criteria, such as Ported Office Code match, are still required in order for a query to be performed.
- For NANP-LNP-QUERY value NA, for call-types other than local, interLATA, toll, toll-free and INTL-WZ1, if a Call Type Profile entry for the given call-type (for example, national) is not present, or the Call Type Profile entry has LNP-QUERY=N, a query will not be performed.

For additional information on call types, refer to [Appendix A, “Call Types and Subtypes.”](#)

LNP-QUERY

This flag is used if the ALL-CALL-QUERY flag in the LNP-PROFILE table is set to Y and the ACQ-LNP-QUERY token in the Destination table is set to ACQ-BASED-ON-CALL-TYPE.

International WZ1 (INTL_WZ1) Preferred Carrier Routing

This section describes the preferred carrier (PIC) routing for an international world zone 1 call. In the past releases, the BTS 10200 supported preferred carrier (PIC) routing based on the routing application defined for the North America PSTN environment. [Table 2-6](#) lists the general preferred carrier routing behavior in prior releases of the BTS 10200.

Table 2-6 General Preferred Routing

CALL TYPE	PIC	Description
CALLTYPE_INTERLATA CALLTYPE_INTL_WZ1	PIC1	Uses SUBSCRIBER.PIC1 to route the call. If PIC1 is not provisioned then route the call to POP.LECOSS.
CALLTYPE_TOLL	PIC2	If POP.ITY is set to Y then uses SUBSCRIBER.PIC2 to route the call. Otherwise, route the call according to the provisioning defined in DIAL_PLAN.
CALLTYPE_INTL	PIC3/PIC1	Uses SUBSCRIBER.PIC3 to route the call if PIC3 is provisioned. If PIC3 is not provisioned then use SUBSCRIBER.PIC1 to route the call. If neither PIC1 nor PIC3 is provisioned then route the call to POP.LECOSS.

Because different customers have different needs regarding the routing for INTL_WZ1 calls, the flexibility of preferred carrier routing for INTL_WZ1 calls has been enhanced as shown in [Table 2-7](#).

Table 2-7 Enhanced Preferred Routing

CALL TYPE	PIC	Description
CALLTYPE_INTERLATA	PIC1	Uses SUBSCRIBER.PIC1 to route the call. If PIC1 is not provisioned then route the call to POP.LECOSS. Filter: CARRIER: INTER

Table 2-7 Enhanced Preferred Routing (continued)

CALL TYPE	PIC	Description
CALLTYPE_INTL_WZ1	PIC1	CA-CONFIG:INTL_WZ1_USE_PIC3 = N Uses SUBSCRIBER.PIC1 to route the call. If PIC1 is not provisioned then route the call to POP.LECOSS. Filter: CARRIER: INTER or CARRIER: INTL (Allow call goes through if either one set to Y)
	PIC3/PIC1	CA-CONFIG:INTL_WZ1_USE_PIC3 = Y Uses SUBSCRIBER.PIC3 to route the call if PIC3 is provisioned. If PIC3 is not provisioned then use SUBSCRIBER.PIC1 to route the call. If neither PIC1 nor PIC3 is provisioned then route the call to POP.LECOSS. Filter: CARRIER: INTER or CARRIER: INTL (Allow call goes through if either one set to Y)
CALLTYPE_TOLL	PIC2	If POP.ITP is set to Y then uses SUBSCRIBER.PIC2 to route the call. Otherwise, route the call according to the provisioning defined in DIAL_PLAN. Filter: CARRIER: INTRA
CALLTYPE_INTL	PIC3/PIC1	Uses SUBSCRIBER.PIC3 to route the call if PIC3 is provisioned. If PIC3 is not provisioned then use SUBSCRIBER.PIC1 to route the call. If neither PIC1 nor PIC3 is provisioned then route the call to POP.LECOSS. Filter: CARRIER: INTL

There is no change to CALLTYPE_INTERLLATA, CALLTYPE_TOLL, and CALLTYPE_INTL. The CALLTYPE_INTL_WZ1 has two different flavors of preferred carrier routing controlled by the CA-CONFIG:INTL_WZ1_PIC3 flag.

For operator assisted calls, there are minor differences between PIC2 and PIC1/PIC3. A call associated with PIC1 or PIC3 is routed to the PIC1/PIC3 carrier if the SUB_PROFILE.EA_USE_PIC1 is set to Y, otherwise the call is routed to POP.LECOSS. A associated with PIC2 is routed to the PIC2 carrier.

**Note**

When a call is routed to any PICx carrier but the specific carrier does not support it (CARRIER.OP-SERVICES=N), the will be rerouted to POP.LECOSS.

Casual calls are routed to PICx carrier according to the call type if the specified carrier supports casual calls (CARRIER.CASUAL=N), otherwise the call is blocked.

**Note**

Enhanced preferred routing affects the entire system for CALL TYPE INTL_WZ1 routing. All subscriber originated CALL TYPE INTL_WZ1 calls use preferred carrier routing. In another words, the BTS 10200 does not allow one subscriber to use PIC1 while other subscribers use PIC3 for CALL TYPE INTL_WZ1 calls.

Call Types

This section provides detailed information on the Cisco BTS 10200 call types. Information on the following call types is provided:

- [1+ InterLATA Call](#)
- [1+ IntraLATA Call](#)
- [0+ InterLATA Call](#)
- [0+ IntraLATA Call](#)
- [Ported-In Call Processing](#)
- [Operator Services](#)

For additional information on call types, refer to [Appendix A, “Call Types and Subtypes.”](#)

1+ InterLATA Call

This section provides a detailed description of the Cisco BTS 10200 routing and call flow for 1+ interLATA calls. Refer to [Figure 2-18](#) for visual representation of the 1+ interLATA call routing flow and review the following detailed 1+ interLATA call routing flow.

-
- Step 1** A 1+ interLATA call is received.
- Step 2** Determine if a 101XXXX number has been dialed. If a 101XXXX number has been dialed, the Cisco BTS 10200 will select the call route and routes the call based on the carrier access code (CAC). If a 101XXXX number has not been dialed, proceed to Step 3.
- Step 3** Check the subscriber table to determine if a PIC is defined. If a PIC is defined, the Cisco BTS 10200 will select the call route and route the call based on the PIC information. If a PIC is not defined, proceed to Step 4.
- Step 4** Check the point of presence (POP) table and verify if a block-eawopic is configured. If the block-eawopic is configured, the Cisco BTS 10200 will block the call. If a block-eawopic is not configured, proceed to Step 5.
- Step 5** Determine if a local exchange carrier operations support system (LECOSS) is defined in the POP table. If a LECOSS is defined in the POP table, the Cisco BTS 10200 will select to route the call via the LECOSS. If a LECOSS is not defined in the POP table, the Cisco BTS 10200 will block the call.
-

Figure 2-18 1+ InterLATA Call

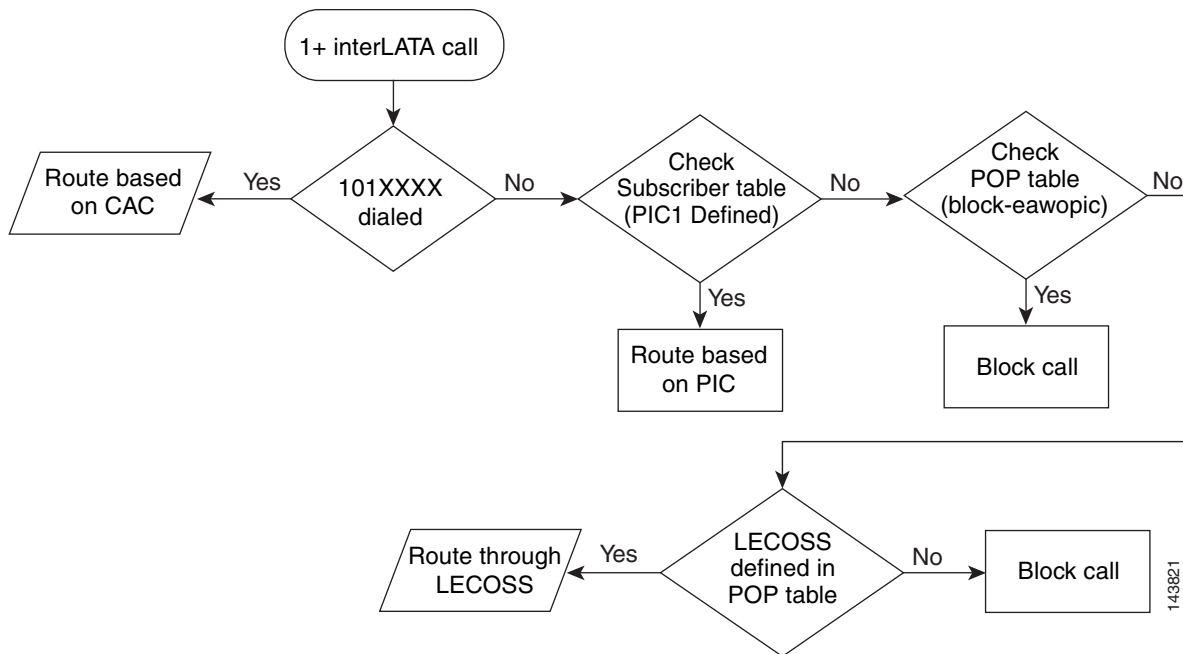

1+ IntraLATA Call

This section provides a detailed description of the Cisco BTS 10200 routing and call flow for 1+ intraLATA calls. Refer to [Figure 2-19](#) for visual representation of the 1+ intraLATA call routing flow and review the following detailed 1+ intraLATA call routing flow.

-
- Step 1** An 1+ intraLATA call is received.
- Step 2** Determine if 101XXXX number has been dialed. If a 101XXXX number has been dialed proceed to Step 3. If a 101XXXX number has not been dialed, proceed to Step 4.
- Step 3** Check the carrier table for a carrier access code (CAC). If a CAC is available, the Cisco BTS 10200 will select the call route and route the call based on the CAC. If a CAC is not available, proceed to Step 3a.
- Determine if a LECOSS is defined in the POP table. If a LECOSS is defined in the POP table, the Cisco BTS 10200 will select the call route and route the call via the LECOSS. If a LECOSS is not defined in the POP table, the Cisco BTS 10200 will block the call.
- Step 4** Check the POP table for a configured IP transfer point (ITP). If an ITP is configured, proceed to Step 4a. If an ITP is not configured, the Cisco BTS 10200 will route the call via dial plan routing.
- Check the subscriber table for a specified PIC. If a PIC is specified, proceed to Step 4b. If a PIC is not specified, the Cisco BTS 10200 will route the call to the announcement server and will check the POP table for a specified PIC. If a PIC is not specified, the Cisco BTS 10200 will block the call or if a dial plan is available, the Cisco BTS 10200 will select the call route and route the call according to the dial plan routing information.
 - Check the intracarrier table for a specified PIC. If a PIC is specified in the intra carrier table, the Cisco BTS 10200 will select the call route and routes the call based on the PIC information. If a PIC is not specified in the intra carrier table, proceed to Step 4c.

- c. Determine if a LECOSS is defined in the POP table. If a LECOSS is defined in the POP table, the Cisco BTS 10200 will select the call route and route the call via the LECOSS. If a LECOSS is not defined in the POP table, the Cisco BTS 10200 will block the call.

Figure 2-19 1+ IntraLATA Call

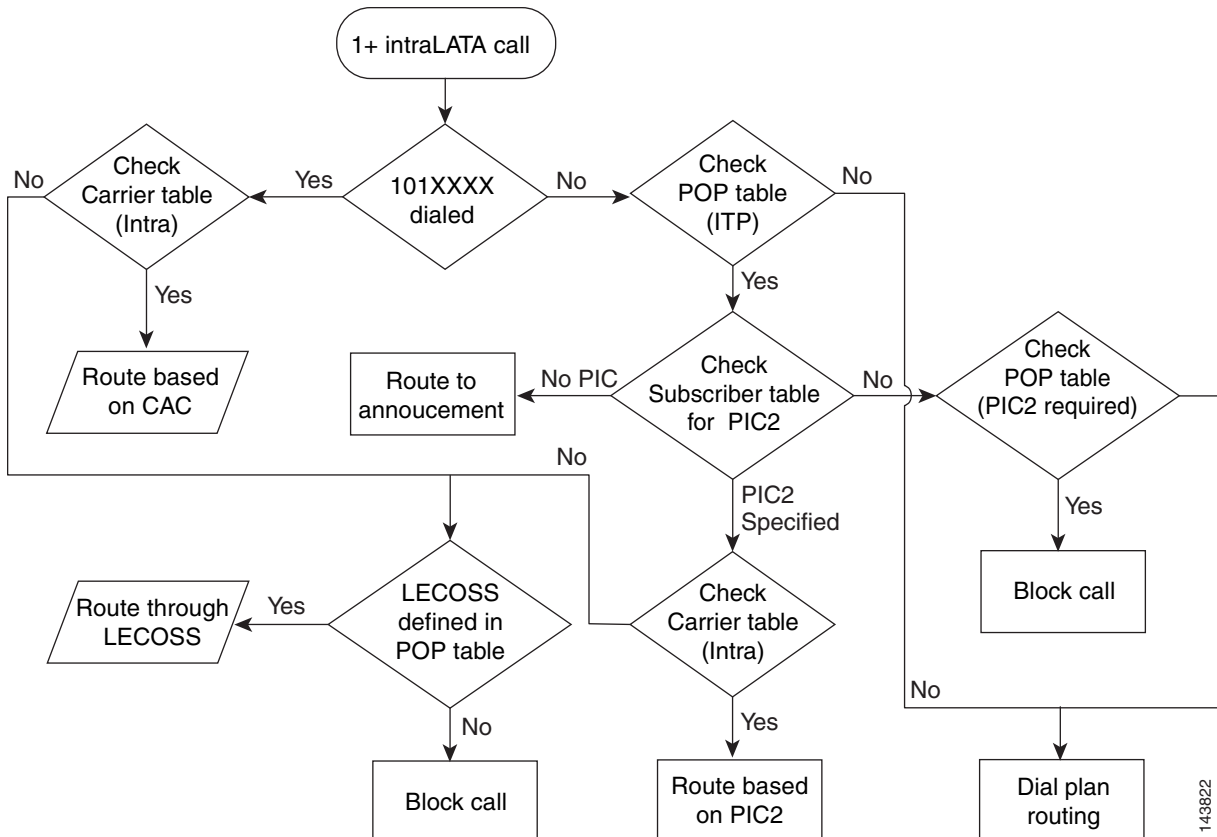

0+ InterLATA Call

This section provides a detailed description of the Cisco BTS 10200 routing and call flow for 0+ interLATA calls. Refer to [Figure 2-20](#) for visual representation of the 0+ interLATA call routing flow and review the following detailed 0+ interLATA call routing flow.

- Step 1** A 0+ interLATA call is received.
- Step 2** Determine if a 101XXXX number has been dialed. If a 101XXXX number has been dialed proceed to Step 3. If a 101XXXX number has not been dialed proceed to Step 5.
- Step 3** Check the carrier table for a CAC. If a CAC is available, the Cisco BTS 10200 will select the call route and route the call based on the CAC. If a CAC is not available, proceed to Step 4.
- Step 4** Check the POP table for a defined LECOSS. If a LECOSS is defined in the POP table, the Cisco BTS 10200 will route the call via the LECOSS. If a LECOSS is not defined in the POP table, the Cisco BTS 10200 will block the call.

- Step 5** Check the subscriber table for a defined PIC. If a PIC is defined in the subscriber table, proceed to Step 6. If a PIC is not defined in the subscriber table, proceed to Step 7.
- Step 6** Check the subscriber profile for ea-use-pic entry. If the subscriber profile contains an ea-use-pic entry, the Cisco BTS 10200 will select the call route and route the call based on the PIC information. If the subscriber profile does not contain an ea-use-pic entry, return to Step 4.
- Step 7** Check the POP table for a block-eawopic entry. If the POP table contains a block-eawopic entry, the Cisco BTS 10200 will block the call. If the POP table does not contain a block-eawopic entry, return to Step 4.

Figure 2-20 0+ InterLATA Call

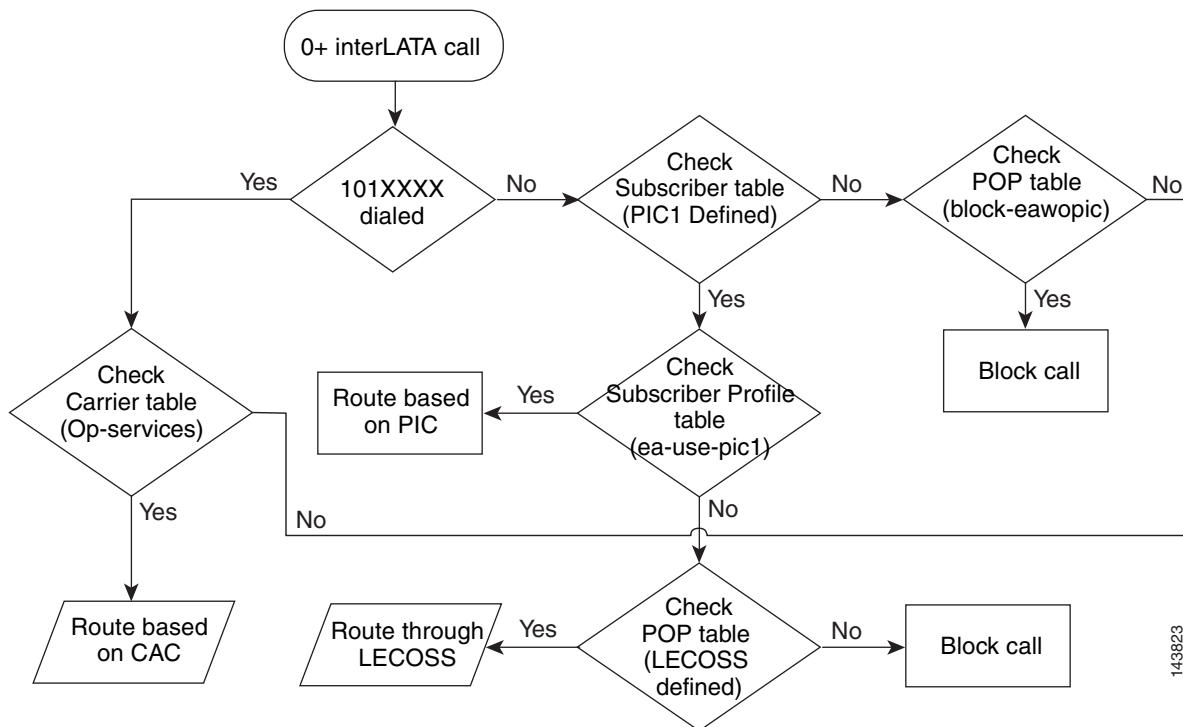

0+ IntraLATA Call

This section provides a detailed description of the Cisco BTS 10200 routing and call flow for 0+ intraLATA calls. Refer to [Figure 2-21](#) for visual representation of the 0+ intraLATA call routing flow and review the following detailed 0+ intraLATA call routing flow.

- Step 1** A 0+ intraLATA call is received.
- Step 2** Determine if a 101XXXX number was dialed. If a 101XXXX number was dialed, proceed to Step 3. If a 101XXXX number was not dialed, proceed to Step 5.
- Step 3** Check the carrier table for a CAC. If a CAC is available, the Cisco BTS 10200 will select the call route and route the call based on the CAC. If a CAC is not available, proceed to Step 4.

- Step 4** Check the POP table for a defined LECOSS. If a LECOSS is defined in the POP table, the Cisco BTS 10200 will route the call via the LECOSS. If a LECOSS is not defined in the POP table, the Cisco BTS 10200 will block the call.
- Step 5** Check the POP table for a configured ITP. If an ITP is configured, proceed to Step 6. If an ITP is not configured return to Step 4.
- Step 6** Check the subscriber table for a specified PIC. If a PIC is specified, proceed to Step 7. If a PIC is not specified, the Cisco BTS 10200 will route the call to the announcement server. Additionally, if a PIC is not specified in the subscriber table, the Cisco BTS 10200 will check the POP table for a specified PIC. If a PIC is specified in the POP table, the Cisco BTS 10200 will block the call. If a PIC is not specified in the POP table, return to Step 4.
- Step 7** Check the intracarrier table for the specified PIC. If the specified PIC is included in the intracarrier table, the Cisco BTS 10200 will select the call route and route the call based on the PIC information. If the specified PIC is not included in the intra carrier table, return to Step 4.

Figure 2-21 0+ IntraLATA Call

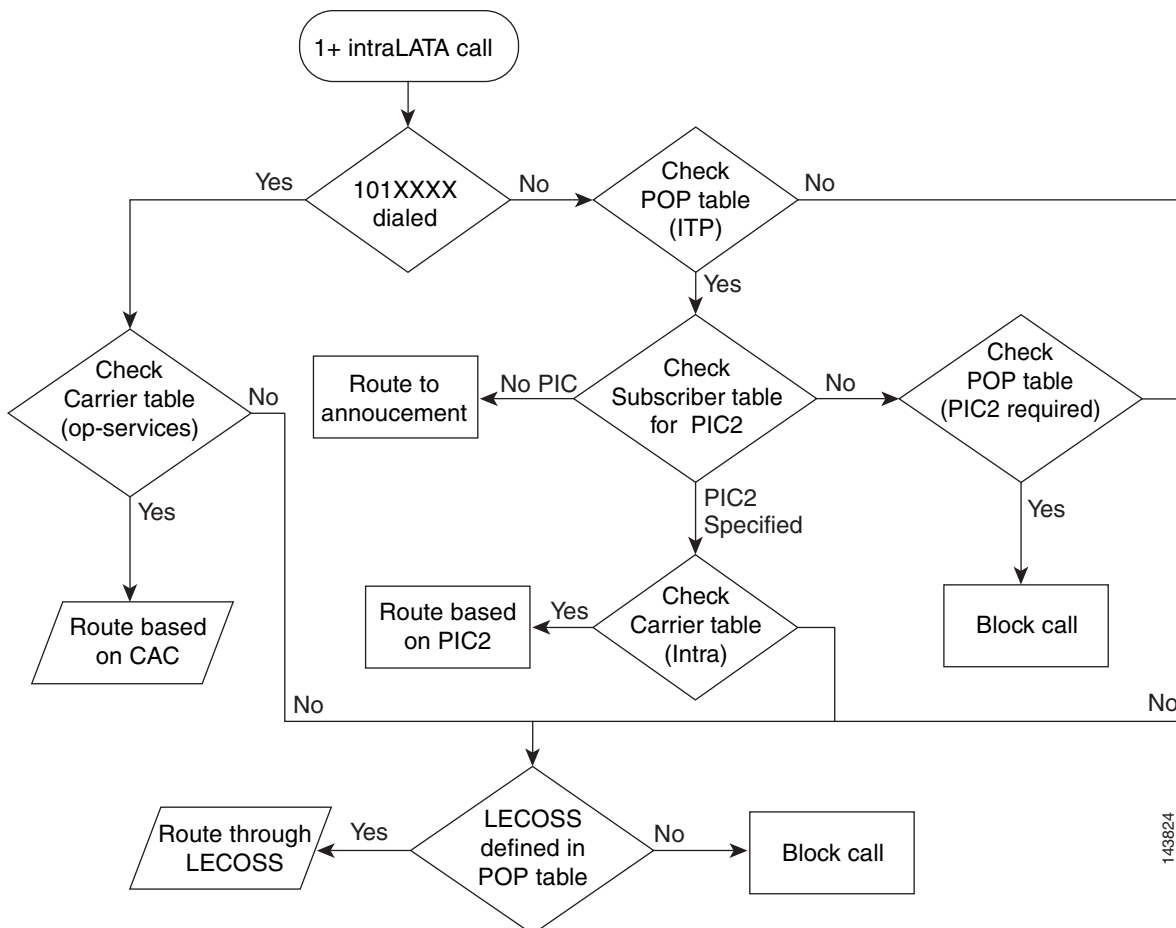

Ported-In Call Processing

This section provides a detailed description of the Cisco BTS 10200 routing and call flow for ported-in call processing calls. Refer to [Figure 2-22](#) for visual representation of the ported-in call processing call routing flow and review the following detailed ported-in call processing call routing flow. Note that in [Figure 2-22](#) the call flow logic applies to American National Standards Institute (ANSI)/North America; for International Telecommunication Union (ITU) local number portability (LNP), the logic is different. For a complete explanation of the call processing logic for ITU LNP, refer to the “[NOA Routing \(ITU Local Number Portability\)](#)” section on page 2-12.

-
- Step 1** A ported-in call is received.
- Step 2** The office code is not assigned to the Cisco BTS 10200.
- Step 3** Determine if the office code is in the ported-in office code table. If the office code is in the ported-in office code table, proceed to Step 4. If the office code is not in the ported-in office code table, perform normal call processing.
- Step 4** Determine if the in-call agent flag is set. If the in-call agent flag is set, proceed to Step 5. If the in-call agent flag is not set, the Cisco BTS 10200 will perform an LNP query.
- Step 5** Determine if the subscriber is included in the dn2subscriber table. If the subscriber is included in the dn2subscriber table, proceed to Step 6. If the subscriber is not included in dn2subscriber table, proceed to Step 7.
- Step 6** Determine if the LNP trigger flag is set. If the LNP trigger flag is set, the Cisco BTS 10200 will perform an LNP query and port out the call. If the LNP trigger flag is not set, the Cisco BTS 10200 will check the status field to determine if a LNP trigger has been assigned and will port out the call or terminate the call to the subscriber.
- Alternately, if dn2subscriber STATUS=PORTED-OUT, or LNP-TRIGGER=Y an LNP query is performed, and depending upon the result of the query (whether or not an local routing number (LRN)/RN is found), the call may be routed to a ported-in DN, routed out to a DN ported-in to another switch, or routed in or out if the DN is not ported at all. Additionally, the call may fail if routing is not possible.
- Step 7** Check the destination table for the subscriber information. Based on the destination table information, the Cisco BTS 10200 will route the call or issue a subscriber terminator, release the call, and play the released call announcement. As part of routing the call, the Cisco BTS 10200 will perform an LNP query and, if necessary, port out the call.
-

Figure 2-22 Ported-In Call Processing

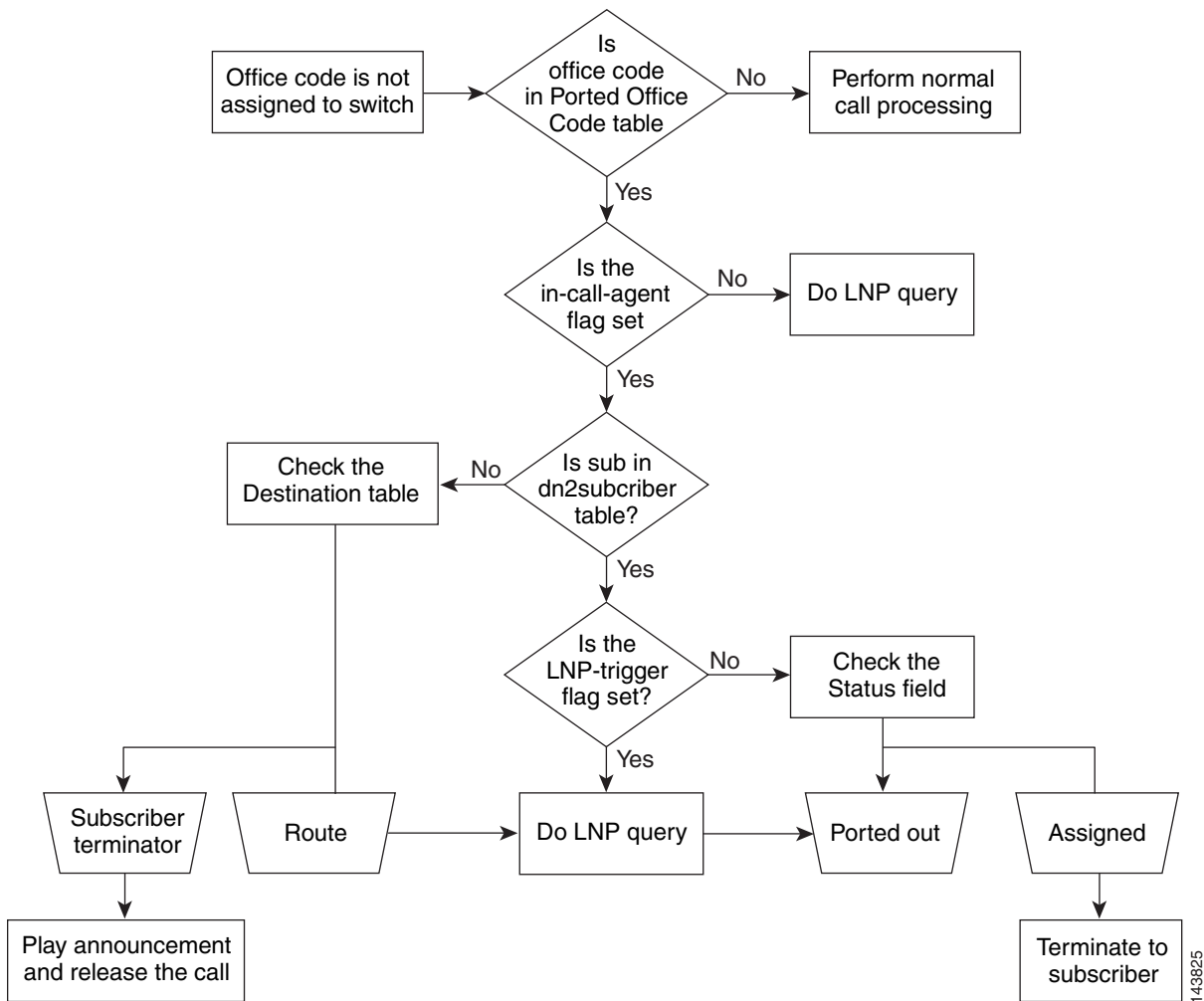

143825

Operator Services

The Operator Services feature allows routing of operator calls to a Feature Group D Operator Trunk (FGD OS) using the CAS MF Operator Package (MO). The following operator calls are included:

- 0-
- 0+
- 00
- 01+CC+NN
- 10XXXXXX + 0-
- 10XXXXXX + 0+
- 10XXXXXX + 00
- 10XXXXXX + 01+CC+NN

The operator call is routed to a CAS MO trunk group by sending the called number followed by information digits (I or II) and the calling number (ANI) to the trunk group. All of these digits are outputted to the CAS MO trunk group by use of multifrequency (MF) signaling. The information digits and ANI can be delivered in any one of these formats (configurable on a per terminating trunk basis):

- I + 7 digit ANI
- I + 10 digit ANI
- II + 7 digit ANI
- II + 10 digit ANI

Prerequisites

The Dial Plan table must be provisioned with a dial plan for operator calls.

An operator CAS MO terminating trunk group must be provisioned.

Supported Interfaces

Table 2-8 shows the interface support between call origination and termination.

Table 2-8 Operator Services Supported Interfaces

Originations	RGW Termination	CAS Termination	SS7 Termination	ISDN Termination	SIP Termination
RGW		X			
CAS		X			
SS7		X			
ISDN		X			
SIP		X			

**Note**

These calls can be terminated to another type of trunk group such as ISDN, SS7, or SIP, but in these cases the calls are treated as regular calls.

Provisioning Operator Services

To provision operator services, perform the following steps:

-
- Step 1** Add the CAS trunk group profile and the operator trunk group.
- ```
add cas-tg-profile id=cas-OPS0; type=MO-10II; oss-sig=y; test-line=n;

add trunk-grp id=1500; tg-type=CAS; dial-plan-id=dpcas; sel-policy=LRU;
direction=outgoing; glare=ODD; tg-profile-id=cas-OPS0; call-agent-id=CA166; status=oos;
```
- Step 2** Add the operator trunk terminations to the Termination Prefix table.
- ```
add termination prefix=cas/ops/mo/; mgw-id=224.14:2434; type=TRUNK; mgcp-pkg-type=MO;
port-start=1; port-end=24;

add trunk cic-start=5; cic-end=8; tgn-id=1500; termination-prefix=cas/ops/mo/;
mgw-id=224.14:2434; termination-port-start=5; termination-port-end=8;
```
- Step 3** Add the operator routes.
- ```
add route id=ops1500; tgn1-id=1500; lcr=y;

add route-guide id=ops1500; policy-type=route; policy-id=ops1500;
```
- Step 4** Add the carrier ID and put the carrier in service.
- ```
add carrier id=0510; intra=y; intl=y; route-guide-id=ops1500; use-dial-plan=y;

change carrier id=0510; status=ins;
```
- Step 5** Add the destination IDs.
- ```
add destination dest-id=ops-toll; call-type=toll; route-type=route;
route-guide-id=ops1502; zero-plus=y;

add destination dest-id=ops-interLATA; call-type=interLATA; route-type=route;
route-guide-id=ops1501; zero-plus=y;

add destination dest-id=ops-intl; call-type=intl; route-type=route;
route-guide-id=ops1503; zero-plus=y;
add dial-plan id=dpcas; digit-string=817-313; reqd-digits=10; dest-id=ops-toll;
```
- Step 6** Add the dial plan and international dial plan.
- ```
add dial-plan id=dpcas; digit-string=404-313; reqd-digits=10; dest-id=ops-interLATA;

add intl-dial-plan cc=42; min-digits=6; max-digits=16; dest-id=ops-intl;
```
-

Policy-Based Flexible Routing

The Cisco BTS 10200 policy-based flexible routing use policy based routing tree decisions to select the call route and to route the call. Flexible routing allows service providers to provision policy based flexible routing by configuring the route guide table using the policy variables. The order of the policies is provisionable and one or more policies can be assigned. [Figure 2-23](#) illustrates the Cisco BTS 10200 flexible routing tree structure. This section includes information describing each of the Cisco BTS 10200 policy types.

Figure 2-23 Flexible Routing Tree Structure

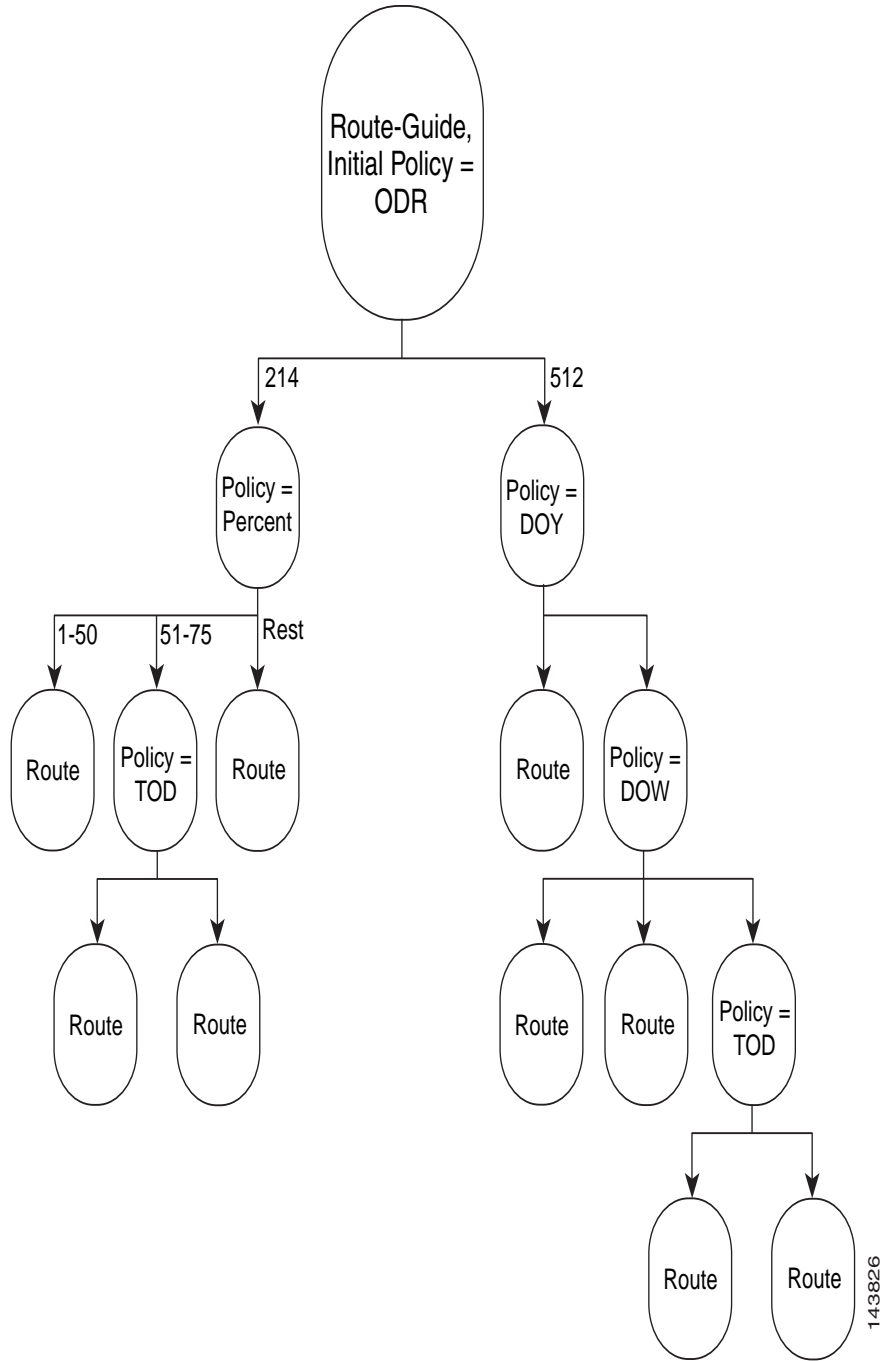

Each of the following policies is described:

- [Day of Year, Day of Week, and Time of Day Policy](#)
- [Origin Dependent Routing Policy](#)
- [Originating Line Information Policy](#)
- [NXX Policy](#)
- [Percent Policy](#)
- [Point of Presence Policy](#)
- [Prefix Policy](#)
- [Region Profile](#)
- [Region Policy](#)
- [Call Type Policy](#)
- [Circuit Code Policy](#)
- [Server Policy](#)

Day of Year, Day of Week, and Time of Day Policy

The Policy Day of Year, Day of Week, and Time of Day enables the flexible routing of calls via the Cisco BTS 10200 by day of year (DOY), day of week (DOW), or time of day (TOD). The Policy Time of Day (policy-tod) table provides routing information based on the following values, in order of preference (highest preference to lowest):

- Day of year
- Day of week
- Time of day

For token names and description details for the Policy Time of Day table, refer to the [Cisco BTS 10200 Softswitch CLI Database](#).

Origin Dependent Routing Policy

The Policy Origin Dependent Routing (policy-odr) table is used for origin-dependent routing. The NPA (or NPA-NXX) of the calling party number selects a route. If no match is found based on the calling party number, the route marked as default routes the call. For token names and description details for the Policy Origin Dependent Routing table, refer to the [Cisco BTS 10200 Softswitch CLI Database](#).

Originating Line Information Policy

The Policy Originating Line Information policy enables the flexible routing of calls via the Cisco BTS 10200 by the use of originating line information (OLI). The Policy Originating Line Information enables routing to be performed based on the originating line information of the calling party number. For token names and description details for the Policy Originating Line Information table, refer to the [Cisco BTS 10200 Softswitch CLI Database](#).

NXX Policy

The Policy NXX (policy-nxx) table is used when a number service calls result in a translated number, translated carrier ID, translated number and carrier ID, or translated route ID. For token names and description details for the Policy NXX table, refer to the [Cisco BTS 10200 Softswitch CLI Database](#).

**Note**

The original call type is preserved in billing when the routing number is changed by the use of the Policy NXX table.

Percent Policy

The Policy Percent (policy-percent) table distributes traffic based on percent allocation. This type of traffic distribution is used primarily for local 8XX routing and Tandem applications. For token names and description details for the Policy Percent table, refer to the [Cisco BTS 10200 Softswitch CLI Database](#).

Point of Presence Policy

The Policy Point of Presence enables the flexible routing of calls via the Cisco BTS 10200 based on the point of presence (POP). The POP based policy routing routes a call to the nearest trunk group when there are multiple trunk groups. There are several situations where a policy POP can be used. If a Call Agent serves several POPs, each POP can have its own announcement server. A POP-specific announcement server can be more efficient than a centralized announcement server. interLATA carriers also have a point of presence in each POP. Route interLATA or international calls to the nearest carrier location using policy POP routing. For token names and description details for the Policy Point of Presence table, refer to the [Cisco BTS 10200 Softswitch CLI Database](#).

Prefix Policy

The Policy Prefix enables the flexible routing of calls via the Cisco BTS 10200 based on prefix (type of call). Typical call types include 1+ dialing, international calls, toll-free, and so on. The Policy Prefix is used mainly for carrier routing. For token names and description details for the Policy Prefix table, refer to the [Cisco BTS 10200 Softswitch CLI Database](#). For additional information on call types, refer to [Appendix A, "Call Types and Subtypes."](#)

Region Profile

The Region Profile (region-profile) table groups North American Numbering Plan (NANP) digits to an originating region. There can be many ID and digit-string combinations for a given region. In this conceptual relationship, a number of digit patterns (digit-string) can belong to a given region and a number of originating regions make up a region profile (ID). Use the value specified in the ca-config record as the default region where type=default-region. For token names and description details for the Region Profile table, refer to the [Cisco BTS 10200 Softswitch CLI Database](#).

Region Policy

The Policy Region enables the flexible routing of calls via the Cisco BTS 10200 based on the call region. The region is derived using the Region Profile table from the Route Guide table and the calling party number ANI. If ANI is not available or the Region Profile table is not provisioned, the region assigned to the trunk group is used for trunk origination. If a record cannot be found based on the region, the record with region=default (if provisioned) is used for routing. For token names and description details for the Policy Region table, refer to the [Cisco BTS 10200 Softswitch CLI Database](#).

Call Type Policy

The Policy Call Type (policy-call-type) table defines a route based on the call type. For token names and description details for the Policy Call Type table, refer to the [Cisco BTS 10200 Softswitch CLI Database](#).

For additional information on call types, refer to [Appendix A, “Call Types and Subtypes.”](#)

Circuit Code Policy

The Policy Circuit Code (policy-circuit-code) table defines a route based on the Circuit Code received in the TNS parameter. For token names and description details for the Policy Circuit Code table, refer to the [Cisco BTS 10200 Softswitch CLI Database](#).

Server Policy

The Policy Server (policy-server) table defines a route based on the Circuit Code received in the TNS parameter. For token names and description details for the Policy Server (AGGR) table, refer to the [Cisco BTS 10200 Softswitch CLI Database](#).



CHAPTER 3

Local Exchange Routing Guide

Revised: December 9, 2008, OL-15637-04

Introduction

This chapter provides a basic understanding of the Cisco BTS 10200 Softswitch local exchange routing guide (LERG). This chapter is divided into the following sections:

- [Local Exchange Routing Guide Support](#)
- [LERG, TNS, and Additional SIP Extensions for CMS-MGC Separation](#)

Local Exchange Routing Guide Support

Local Exchange Routing Guide Support enables you to utilize the routing data from the LERG files, and it allows you to view, add, delete, and change the data stored in the LERG tables. Also, it provides the means to schedule future LERG updates. A new set of commands and a script have been added to assist in provisioning the LERG data. More information on these commands and on the mechanism for provisioning the LERG data are presented in the subsequent sections.

The Cisco BTS 10200 operations and maintenance (OAM) application allows users to configure the LERG information in the LERG6INS.DAT and LERG6.DAT files. The LERG6.DAT contains the data which needs to be configured on the Cisco BTS 10200 once at any given point in time. The LERG6INS.DAT contains the data which needs to be configured on a specific date in the future. The following two mechanisms are provided on the Cisco BTS 10200 OAM application:

- A single command to generate Cisco BTS 10200-specific LERG commands from the input LERG6.DAT. This command parses the LERG6.DAT and creates a file containing the Cisco BTS 10200-specific command list. This command file is then loaded by means of the FTP adapter and applied to a corresponding table in the Cisco BTS 10200 OAMP application. The command file is also sent to the Call Agent.
- A single command to generate the Cisco BTS 10200 specific LERG commands from the input LERG6INS.DAT file. This command parses the LERG6INS.DAT file and creates a file containing the Cisco BTS 10200-specific command list with appropriate start times. This command file is then loaded by means of the FTP adapter and applied to the corresponding table in the Cisco BTS 10200 OAMP application. The command file is also sent to the Call Agent at the specified start time.

LERG6 Update

This section describes the LERG6 file update process. Refer to [Figure 3-1](#) and review the step-by-step LERG6 file update process.

Figure 3-1 LERG6 Update Process Flow

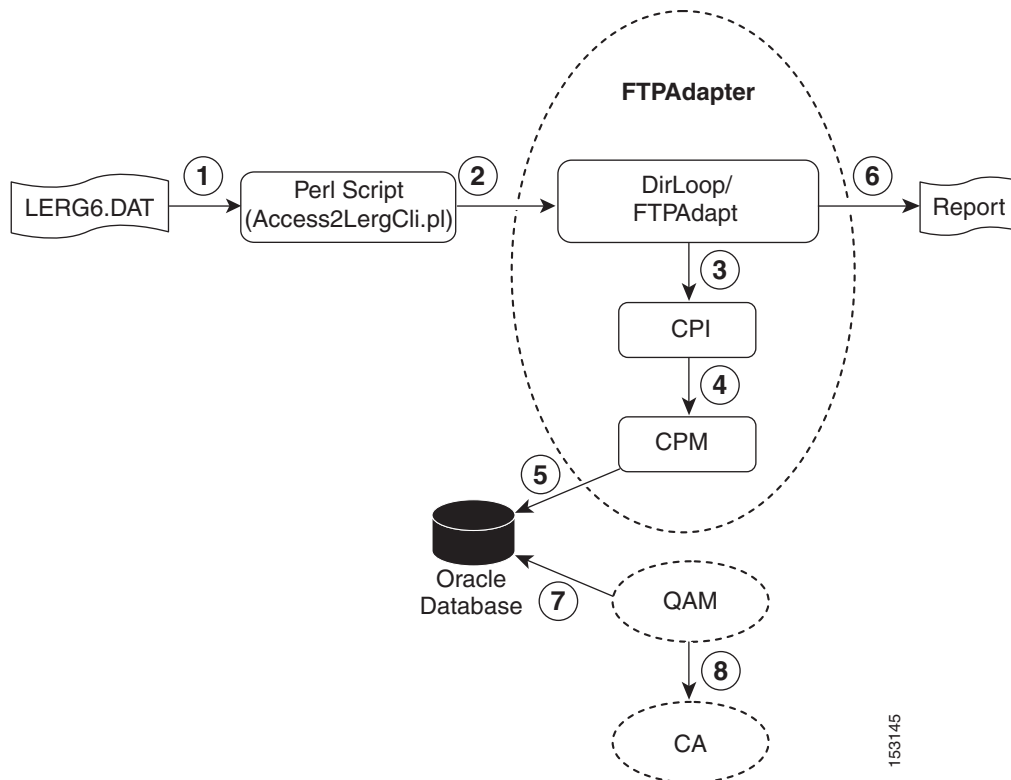

1. The first step in the LERG6 update involves the creation of a Cisco BTS 10200-specific command file using the Access2LergCli script, which is available in the /opt/ems/bin directory. The LERG6.DAT file is provided as an argument to the **lerg6ToCLI** command along with the output file name. The syntax of the **lergToCLI** command is **lergToCLI <<LERG INPUT DATA>> <<OUTPUT FILE>>**.

Example:

The command string `/opt/ems/bin/lergToCLI LERG6.DAT /opt/ems/ftp/deposit/lergCmds` generates the output file `lergCmds` in the `/opt/ems/ftp/deposit` directory.

2. The output file generated by the **lergToCLI** command contains the Cisco BTS 10200-specific command-line interface (CLI) commands. The output file is copied to the `/opt/ems/ftp/deposit` directory.



Note Verify that the generated file has the expected owner. If the file does not have the expected owner, change the owner, using the UNIX **chown** command.

3. The DirLoop thread, which is polling the deposit directory, reads the CLI commands contained in the output file.

4. The CLI commands are then parsed and validated by the Command Processing Infrastructure (CPI) module.
5. The CLI commands are then added into the Oracle database by the Request Manager component of the Command Processing Module (CPM). The Request Manager also creates a transaction request statement and makes an entry into the Transaction Queue.
6. The result of the CLI command execution is contained in a transaction report.
7. The Queuing and Audit Manager (QAM) process reads the transaction request statement from the Transaction Queue.
8. The QAM then forwards the transaction request statement to the Call Agent. Upon receiving the reply from the Call Agent, the OAM deletes the corresponding transaction request statement from the transaction queue.

LERG6INS Update

This section describes the LERG6INS file update process. Refer to [Figure 3-2](#) and review the step-by-step LERG6INS file update process.

Figure 3-2 LERG6INS Update Process Flow

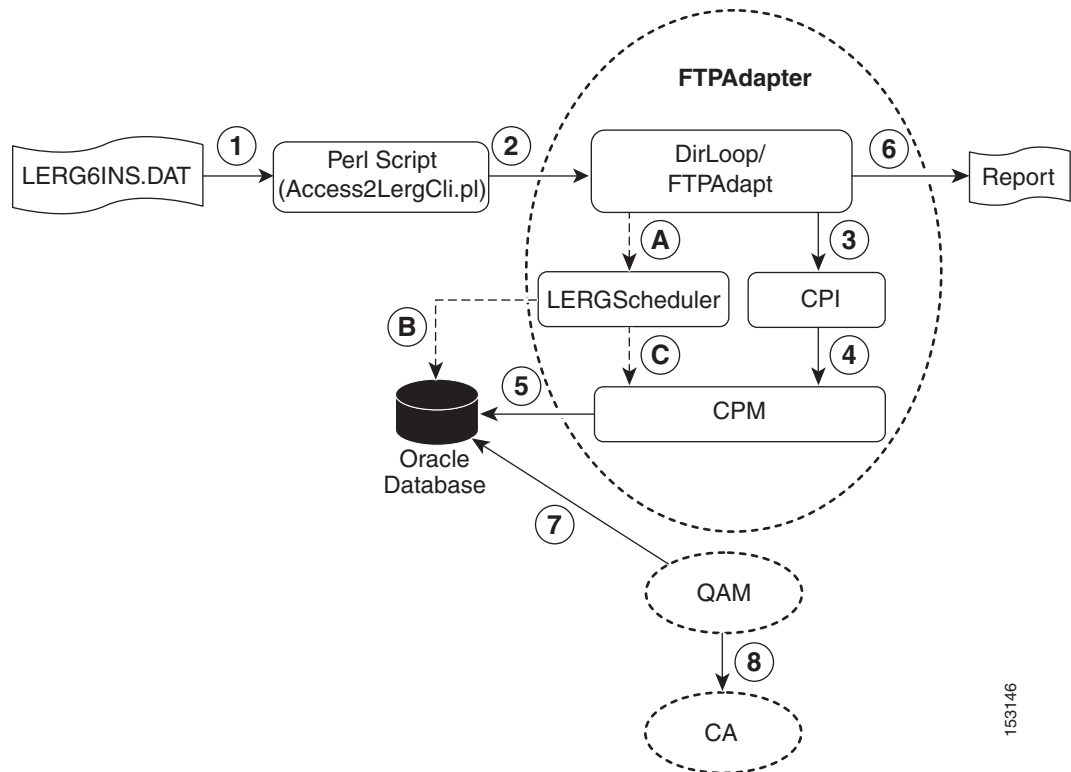

1. The first step in the LERG6INS update involves the creation of a Cisco BTS 10200-specific command file by use of the Access2LergCli script, which is available in the /opt/ems/bin directory. The LERG6INS.DAT file is provided as an argument to the **lerg6ToCLI** command along with the output file name. The syntax of the **lerg6ToCLI** command is **lerg6ToCLI <<LERG INPUT DATA>> <<OUTPUT FILE>>**.

Example:

The command string `/opt/ems/bin/lergToCLI LERG6INS.DAT /opt/ems/ftp/deposit/lergCmds` generates the output file `lergCmds` in the `/opt/ems/ftp/deposit` directory.

2. The output file generated by **lergToCLI** command contains the Cisco BTS 10200 specific CLI commands. The output file is copied to the `/opt/ems/ftp/deposit` directory.

The `Access2LergCli` perl script intelligently parses contents of the `LERG6INS` file and prepares a list which includes parameters and a noun, verb, and start time. The start time is the day on which the LERG data needs to be applied to the Cisco BTS 10200.



Note Verify that the generated file has the expected owner. If the file does not have the expected owner, change the owner using the UNIX **chown** command.

3. The `DirLoop` thread, which is polling the deposit directory, reads the CLI commands contained in the output file.
4. The CLI commands are then parsed and validated by the CPI module.
5. The Request Manager component of CPM distinguishes the regular LERG6 update from scheduled LERG6INS based on the noun. It creates a scheduled job and adds it into `SCHEDULED_COMMAND` and `SCHEDULED_PARAM_TABLE`.
6. The result of the CLI command execution is contained in a transaction report.
 - a. During the start up of the File Transfer Protocol (FTP) Adapter (DLP process), a thread called LERG Scheduler is created to handle the periodic LERG6INS updates.
 - b. This thread wakes up once a day to check the `SCHEDULED_COMMAND` table for any pending LERG-specific jobs.

You can configure the duration of this check by changing the `LERGDuration` parameter in the `bts.properties` file. We recommend that users not change this parameter. Improper tuning of this parameter might affect the performance of the DLP process.



Note Modification of the `bts.properties` file should not be attempted without Cisco TAC support or supervision.

- c. If the LERG Scheduler finds any LERG-related jobs in the `SCHEDULED_COMMAND`, it creates a corresponding LERG6 request and hands it over to CPM. The Request Manager component of CPM updates the LERG6 table in Oracle and creates an entry in the Transaction Queue.
 7. The QAM process reads the transaction request statement from the Transaction Queue.
 8. The QAM then forwards the transaction request statement to the Call Agent. Upon receiving the reply from the Call Agent, OAM deletes the corresponding transaction from the transaction queue.
-

LERG6INS Time Schedule

The LERG6INS scheduler is part of the FTP adapter process (DLP process). This scheduler is driven by the java timer and timer class architecture. The scheduler schedules the LERG6INS task for a specified duration. This duration is specified in the `bts.properties` file.



Note

We recommend that you not change the duration specified in the `bts.properties` file.

Modification of the `bts.properties` file should not be attempted without Cisco TAC support or supervision.

The task is scheduled to run every day at midnight (12:00 a.m.). The task reads all the LERG6INS updates that need to be executed with a date prior to the current date and provisions them. For example, assume that the today's date is 12-10-2005, and we add three `lerg6_ins` entries. The first one has a start time of 10-02-2005, the second has a start time of 12-10-2005, and the third has a start time of 12-15-2005. The task scheduled for today, which starts at 12-10-2005 at 12:00 a.m., checks the database with the entries loaded before or equal to the date 12-10-2005. The task fetches the two entries with the start times of 10-02-2005 and 12-10-2005 but ignores the entry with the start time of 12-15-2005. Hence, LERG6 is provisioned for the two entries with the start time of 10-02-2005 and 12-10-2005 but not for the entry with a start time of 12-15-2005.

System Context for LERG Support

Figure 3-3 illustrates the Cisco BTS 10200 context provisioning for LERG support.

Figure 3-3 Cisco BTS 10200 Context Diagram of LERG Provisioning

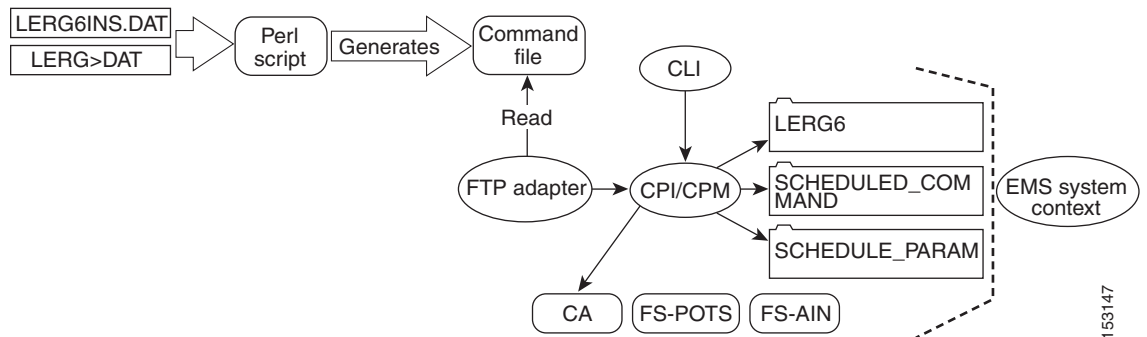

153147

Configuring

The Cisco BTS 10200 LERG Support in OAMP feature configuration utilizes the `lergToCLI` script command to configure the system to create Cisco BTS 10200 specific CLI commands from the input `LERG6.DAT` or `LERG6INS.DAT` file. This script is available in the `/opt/ems/bin` directory.

Operator Interfaces

There are four types of operator interfaces available for LERG provisioning:

- The operator can provision the LERG data on the Call Agent using the one-time configuring mechanism which utilizes the `lergToCLI` command script.
- The operator can schedule provisioning of the LERG data on the Call Agent on a specific date in the future using the `lergToCLI` command script.
- The operator can use CLI commands to add, change, delete, show, or audit the entries in the LERG table.
- The operator can use **show** or **delete** CLI commands to display or delete the currently scheduled LERG data which has not yet been sent to the Call Agent.

CLI Commands



Note

The Cisco BTS 10200 LERG Support in OAMP feature is developed to be used by the **lergToCLI** script command. The CLI option is provided for the sake of troubleshooting and debugging activities. The direct CLI commands using the CLI interface need to be used with discretion because simultaneous operations using the script and CLI interface might lead to complications.

You can use the **show** command to display the LERG6 data.

Examples:

```
show lerg6
```

```
show lerg6;ndc=469;ec=255;thousand_block =1
```

Users can use the **add** command to add the LERG6 data.

Example:

```
add lerg6 ndc=201;ec=007;lata=224;lata_name=NORTH JERSEY NJ;
thousand_block=A;coc_type=ATC;ssc=N;dind=Y;term_digits_ixc2eo=NA;term_digits_ixc2at=7;port
able=N;aocn=7228;ocn=7229;locality=XXXXXXXXXX;state=NJ;rc=XXXXXXXXXX;line_range_from=0000;
line_range_to=9999;switch_clli_code=NBWKNJ17DS1;sha=00;test_line_num=9921;thousand_block_p
ooling=N; lata_loc=224
```

The required attributes for **add lerg6** are:

```
aocn
dind
thousand_block
thousand_block_pooling
ec
portable
term_digits_ixc2eo
term_digits_ixc2at
ocn
ndc
switch_clli_code
```

You can use the **delete** command to delete the LERG6 data.

Example:

```
delete lerg6;ndc=469;ec=255
```

The required attributes for **delete lerg6** are:

```
ec
ndc
thousadn_block
```

You can use the **show** command to display the currently scheduled LERG6INS data.

Examples:

```
show lerg6-ins

show lerg6-ins;start-time=2005-08-08 00:00:00

show lerg6-ins;id=20060808010100
```

You can use the **delete** command to delete the currently scheduled LERG6INS data.

Example:

```
delete lerg6-ins;id=2006010101000
```

The mandatory attribute for **delete** is “ID.”

You can schedule the LERG6INS data update from the CLI using the **add** command.

Example:

```
add lerg6_ins noun=lerg6;verb=add; ndc=201;ec=252; start_time=2006-07-07 00 :00
:00;lata=224;lata_name=NORTH JERSEY NJ; thousand_block=3; coc_type=EOC; ssc=N; dind=Y;
term_digits_ixc2eo=NA;
term_digits_ixc2at=NA;portable=Y;aocn=4051;ocn=0558;locality=CRAGMERE;state=NJ;rc=CRAGMERE
;line_range_from=3000;line_range_to=3999;switch_clli_code=HCKNNJGRDS0;sha=01;test_line_num
=6299;thousand_block_pooling=Y; lata_loc=224
```

The mandatory attributes for **add** are “ec” and “start time.”

To clear all the LERG data, you can use the following **clear** command can be used.

Examples:

```
clear lerg6

clear lerg6-ins
```

LERG6 Table

The Local Exchange Routing Guide (LERG) supports the current local exchange network within the NANP and shows planned changes in the network. For token names and description details for the LERG6 table, refer to the [Cisco BTS 10200 Softswitch CLI Database](#).

LERG6-INS Table

LERG6-ins commands update the LERG6 table on a monthly basis with LERG information from Telcordia. LERG6-INS (in service) commands use the same tokens as the LERG6 table. LERG6-INS reports display changes made since the previous month's LERG. Use the **add** command to schedule a LERG6-INS data update. For token names and description details for the LERG6-INS table, refer to the [Cisco BTS 10200 Softswitch CLI Database](#).

LERG, TNS, and Additional SIP Extensions for CMS-MGC Separation

This section provides an overview of the LERG and TNS functionality.

LERG

The LERG database, provided by Telcordia, contains comprehensive data pertaining to all switches and their serving NPANXX numbers. If a switch's provisioning does not yield a route to a destination using normal Called Party Number analysis through the DIAL-PLAN, the switch should use LERG to figure out the remote switch that serves the NPANXX and route to the remote switch.



Note

LERG data provisioning is applicable only to ANSI/North America market.

This feature is intended to provide routing based on the LERG data supplied by Telcordia. If a called party number analysis does not yield a routing solution, the LERG data is examined to find a remote switch ID and the call is routed based on the remote switch ID.

There are two options to route to a remote switch from the Cisco BTS 10200. The first option is to provision a route to every remote switch in the dial-plan. The second option is to always route to a default destination/route.

The first option entails provisioning an entry in the routing data (dial-plan, destination, route, and so forth) for each of the remote switches in the country. That will yield a lot of entries in the routing data table of the Cisco BTS 10200 and complicates provisioning. The first option does not require any changes to the Cisco BTS 10200. The existing routing schema can be used to provision routes to remote switches.

The second approach would be to simply route to a default destination/route and put the onus on the adjoining switches.

The LERG implementation in the Cisco BTS 10200 uses the second option, the default routing approach. Also, the LERG data is looked up for digit validation and for finding call_type, but the remote_switch ID is ignored. Whether to look up LERG data or not for validating digits and to find call_type is configurable. Configuration of default route and configuration of LERG data lookup are included in the dial-plan-profile. In the dial-plan-profile the default route is configured by the default_dest field and the LERG lookup is configured by use of the lerg_supp field. Each field can be configured independently.

The independent configuration of LERG and default route configuration in dial-plan-profile enables the user to provision the default route with or without LERG lookup. This allows the default route to be configured in international markets where LERG data is not relevant. Additionally, the default route can be used in any routing scenario.

A new call_type policy has been added to enable routing based on the call_type.

[Figure 3-4](#) and [Figure 3-5](#) depict high-level views of routing calls originated from the trunk group and subscriber, respectively. [Figure 3-6](#) shows changes needed for implementing default_routing dial-plan routing. Here default_routing refers to both LERG lookup and looking up the default_dest from dial-plan-profile.

Figure 3-4 Routing of an Incoming Trunk Call

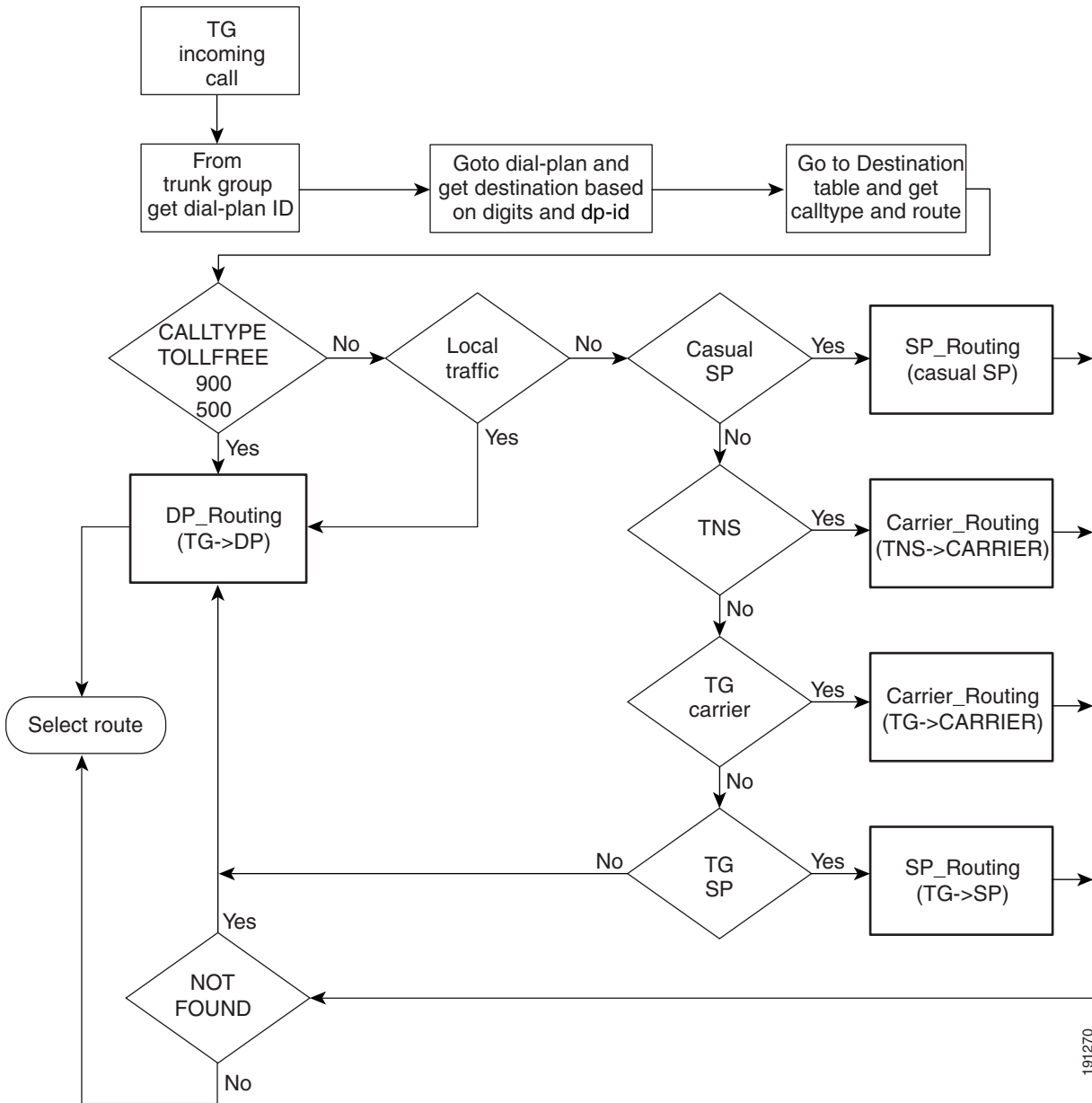

Figure 3-5 Routing on an Incoming Subscriber Call

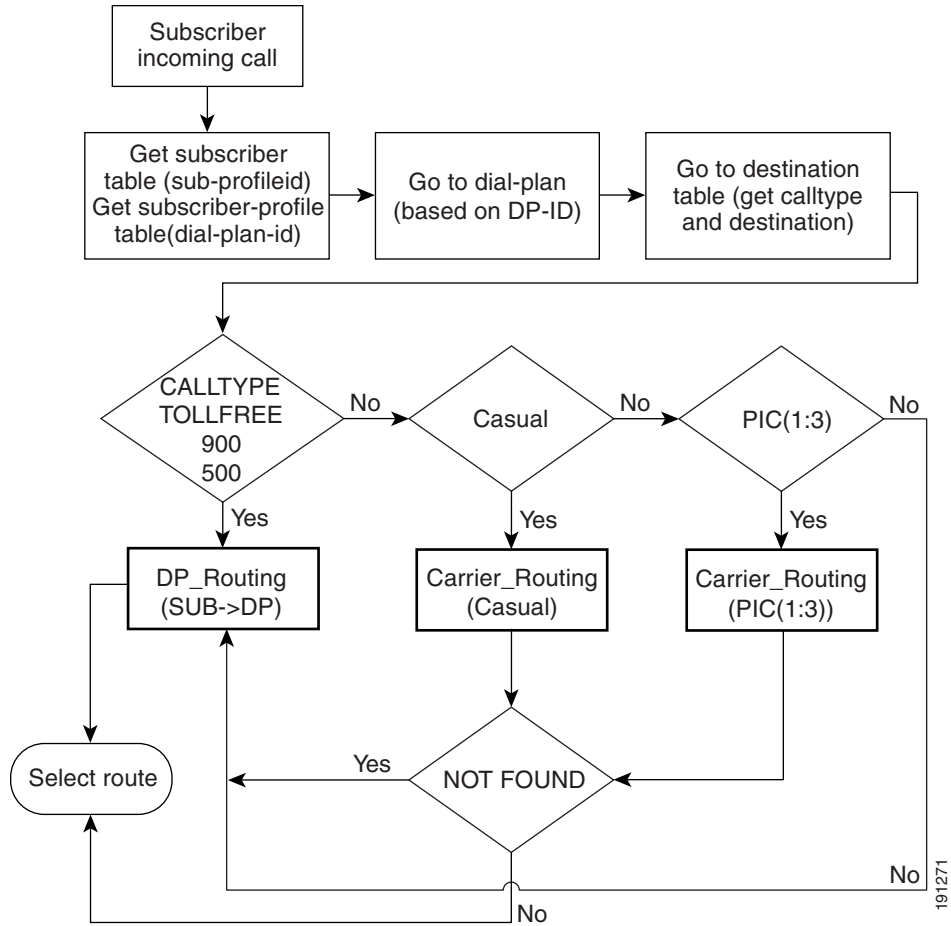
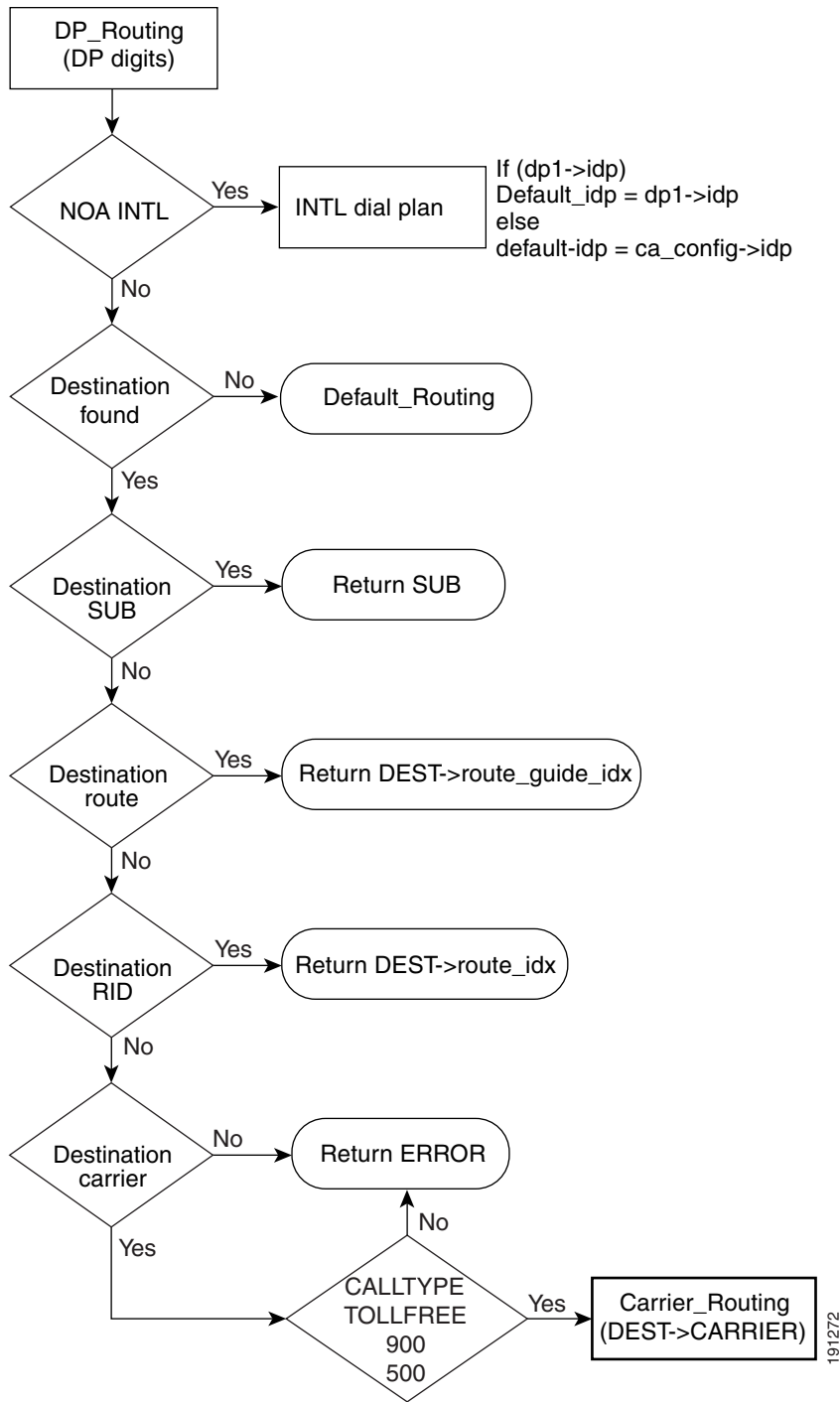

Figure 3-6 Default-Routing Dial-Plan Routing



TNS Routing Modifications

This section describes the TNS routing modifications.

Current TNS Routing Implementation

The current implementation of the Cisco BTS 10200 supports carrier based routing when it receives a TNS parameter in an IAM from PSTN network. In the current implementation, the carrier routing involves three steps: 1) find an entry in the dial-plan with Called Party digits, 2) find call_type based on the destination pointed to by the dial-plan entry, and 3) route using the carrier_id. Step 1 and 2 are mandatory. If an entry is not found in Step 1, the call is failed.

Modified TNS Routing Implementation

The modified TNS routing implementation, stemming from CMS and MGC separation, requires that the MGC routing analysis shall include call_type and carrier_id passed in invite from the NRS. With changes to TNS implementation derived from the MGC routing analysis requirement, the three basic carrier routing steps remain the same. But, with the addition of default routing, the provisioning of the dial-plan will be easier. Per the requirement, a default_dest field is added to the dial-plan-profile table so that if no dial-plan entry is found the default_dest in dial-plan-profile is used. With this, one needs to provide only one default_dest; no entries in the dial-plan are needed. As shown in the call_flow in [Figure 3-7](#), the CMS will pass the call_type and carrier_id from its route analysis; and the NRS, in turn, will pass it to the MGC.

One TG could be provisioned from the NRS to the MGC so that the NRS will channel all calls with call_type and carrier_id on that TG. Then on MGC, the dial-plan-profile is provisioned with the default_dest and no dial-plan entries are needed. The basic need of having a destination is still there, but the provisioning aspect is simplified with the introduction of default routing.

The change is applicable to all calls coming from either PSTN or NRS. However, call_type is expected only on the NRS to MGC trunk and Access Tandem trunk.

Figure 3-7 Call Flow Between a CMS and a MGC via a NRS

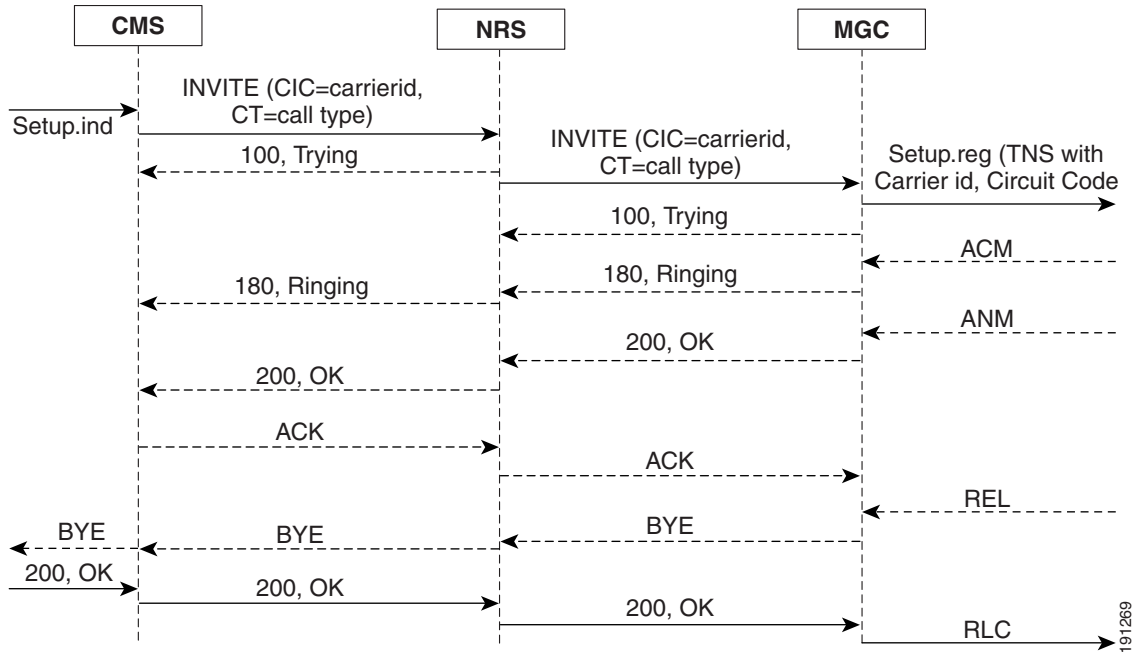

In the current design of the BCM, as shown in [Figure 3-8](#), every incoming call from the TG flows through the dial-plan and the TNS-based routing is accomplished after a destination is found.

The TNS routing is modified to account for the call_type in the setup from NRS. The call_type in Call Data field is initialized with call_type from the Setup field. In addition, a new policy Circuit Code policy is added to route based on the Circuit Code.

Figure 3-8 TNS Routing and Modifications to the General Routing Flow

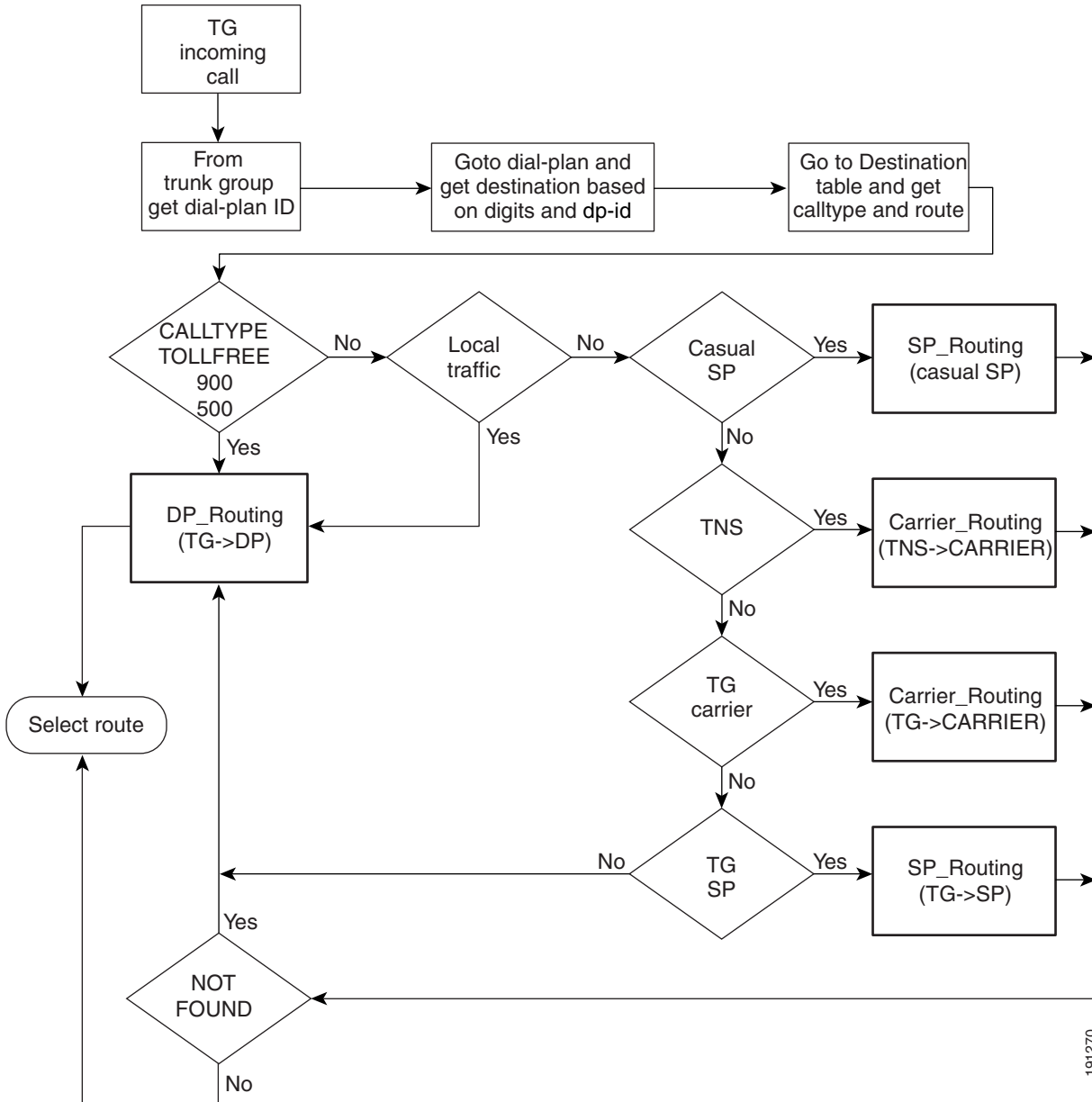

191270

TNS and LERG Feature Use

The routing changes can be summarized as follows:

1. Validating and finding call type using LERG data
2. Route using default route
3. Call_type Policy
4. Circuit Code Policy
5. TNS routing modifications

The first item is only applicable to the North American market.

The first three items in the list are relevant to both MGC and CMS deployments. The last two items on the list above are relevant only to a MGC deployment.

Each one of the above items can be configured independent of the others in the list. For example, default-routing can be provisioned without LERG data and call_type policy can be provisioned without TNS routing, and so forth. This independence enables use of default routing in any scenario. It also enables the use of Call Type and Circuit Code policies in any scenario.

Data Model Changes to Policy Routing Tables

A new default_policy concept and a new policy_profile table are introduced with the introduction of the call_type and circuit code policies.

The new policy_profile table has a 0 to M relationship with all policy tables. So, for every entry in a policy table there is an entry in the policy_profile table, but not vice-versa.

The policy_profile table serves two purposes:

1. It provides a foreign key relationship to the route_guide table. In prior releases, policy associations with route guides were not explicitly enforced. With the introduction of this table, the route_guide entry is associated with the policy_profile entry. Every policy profile entry has an entry in the policy table associated with the policy_type. So, when policy is added to the route_guide, the database checks for its existence in policy_profile.
2. It also provides a place holder for the default policy and default policy types. This enables taking default course of action, if the policy table pointed to by the type field in policy_profile doesn't have an entry. In the current design, only policy_call_type and policy_circuit_code will use this feature. For example, in the case of policy_call_type, for every policy, there can be multiple entries with different call_types. It is possible that there will not be an entry for the call_type of the call being routed. In that instance, the default_policy_type and default_policy_id fields from the policy_profile entry are used to route the call.



Note

Prior to the addition of a policy_call_type entry there must be an entry in policy_profile with TYPE=CTYPE.

Inter-Process Interface (SIA)

In support of CMS/MGC separation in the Packetcable network, several optional extensions are to be added to SIP invite request messages. These extensions carry between the CMS and an MGC, information that is significant to the PSTN. Prior to Release 5.0 some of these types of extensions have been added to the Cisco BTS 10200, including `cic`, `rn`, and `npdi`. The new extensions for Release 5.0 include:

- `ct`—Call Type
- `noa`—Nature of Address
- `cpc`—Calling Party Category
- `dai`—Dial Around Indicator

The values that are being assigned to these new extensions are currently only for the ANSI/North American market. In the future the parameter values can be expanded to include values necessary for other world markets.

These extensions are generally added/encoded on the CMS and decoded on the MGC. This is because the MGC can utilize the extra information for routing and it interfaces to the PSTN, which may utilize the extra information provided in these headers. Because of this, the general rule of thumb when provisioning the associated `softsw-tg-profile` flags for CMS/MGC separation is for these parameters to be set to `send_only` on the CMS and `recv_only` on the MGC.

Call Type, Nature of Address, and Dial Around Indicator are extensions to the user part of the Request URI of a SIP invite message. The Calling Party Category extension is added to the user part of the paid header. These extensions will only be added to the initial SIP invite request.

Call Type

The possible values for call type are as follows:

`"sac-500" / "sac-700" / "sac-900" / "svc-976" / "airlines" / "ambulance" / "ana" / "bly" / "business" / "cut-thru" / "national-opr" / "da" / "da-toll" / "emergency" / "fire" / "info" / "inter-lata" / "international" / "international-opr" / "international-wz1" / "lb-test" / "local" / "lrn" / "mobile" / "national-opr" / "non-emergency" / "opr" / "sip-trigger" / "police" / "premium" / "railways" / "relay" / "repair" / "svc-code" / "tandem" / "test" / "tool" / "toll-free" / "traffic" / "wakeup" / "weather" / "unknown" / "token"`

In the decode direction, the MGC Cisco BTS 10200 will receive incoming SIP invite messages with the call type parameter from an NRS. The NRS does not know about this parameter and just blindly passes it through when it receives it from a CMS Cisco BTS 10200.

For additional information on call types, refer to [Appendix A, "Call Types and Subtypes."](#)

Nature of Address

Nature of Address extension corresponds to the directory number in the Request URI. It is defined in PSTN call signaling protocols to classify the dialed number. It is used in conjunction with Call Type to classify the called party. Its possible values are:

`"unknown" / "subscriber" / "national" / "inter-national" / "opr-req-sub" / "opr-req-nat" / "opr-req-inter-nat" / "opr-req" / "test"`

There is a special scenario for operator calls when the NOA=operator, the BCM will send the call information with an empty called party number. For the operator scenarios that are routed via SIP, there should be a digman associated with the route to append 0 for NOA=OPERATOR.

Also, if you specify MATCH-STRING=^\$; then it will prefix 0 only if there are no digits.

Example:

```
change route ID=60999; TGN1_ID=60999; DEL_DIGITS1=0; DEL_DIGITS2=0; DEL_DIGITS3=0;
DEL_DIGITS4=0; DEL_DIGITS5=0; DEL_DIGITS6=0; DEL_DIGITS7=0; DEL_DIGITS8=0; DEL_DIGITS9=0;
DEL_DIGITS10=0; TG_SELECTION=RR; DNIS_DIGMAN_ID1=Zero_Operator; NEXT_ACTION=NONE; P1=0;
WT1=0; P2=0; WT2=0; P3=0; WT3=0; P4=0; WT4=0; P5=0; WT5=0; P6=0; WT6=0; P7=0; WT7=0; P8=0;
WT8=0; P9=0; WT9=0; P10=0; WT10=0; TYPE=ROUTE;
```

```
Add DIGMAN ID=Zero_Operator; RULE=1; MATCH_STRING=^; REPLACE_STRING=0&;
MATCH_NOA=OPERATOR; REPLACE_NOA=OPERATOR
```

For additional information on call types, refer to [Appendix A, “Call Types and Subtypes.”](#)

Calling Party Category

The Calling Party Category (CPC) characterizes the type of user (or caller) who originates a call. It is used in the PSTN for call routing and call screening purposes. All of the possible CPU values are as follows:

“ordinary” / “prison” / “police” / “test” / “operator” / “payphone” / “unknown” / “hospital” / “cellular” / “cellular-roaming” / “non-coin-toll-free” / “coin-toll-free” / “genvalue”

The CPC extension values only refer to the common values defined in the ANSI/North America market. In ANSI ISUP, this information pertains to the OLI (Originating Line Information) parameter.

Dial Around Indicator

The dial-around-indicator (DAI) is added to the user part of the SIP Request URI of the first outgoing invite message. The DAI shows how the carrier ID code was derived. The DAI has the following values:

- presub—The CIC contains the caller's pre-subscribed carrier.
- presub-da—The CIC contains the caller's dialed carrier-identification-code; the caller has a pre-subscribed carrier. The dialed value is the same as the subscriber's carrier value.
- presub-daUnkwn—The CIC can contain either a caller dialed carrier-identification-code or the caller's pre-subscribed carrier.
- da—The CIC contains the caller's dialed carrier-identification-code; the caller does not have a pre-subscribed carrier.
- CIC-chrgPty—The CIC is the preferred carrier of the charged party.
- altCIC-chrgPty—The CIC is the alternate carrier of the charged party.
- verbal-clgPty—The CIC was delivered verbally by the calling party.
- verbal-chrgPty—The CIC was delivered verbally by the charged party.
- emergency—This is an emergency call.
- operator—The carrier was selected by a network operator.

EMS Changes

The **translate trunk** command is enhanced to add three additional parameters, `call_type`, `circuit_code` and `carrier_id` to translate calls coming with `carrier_id`, `circuit_code` and `call_type`. All three parameters are optional.

Examples:

```
translate trunk; tgn-id=2; call_type=local; called_dn=7034841301; circuit_code=1
translate trunk; tgn-id=2; carrier_id=288; call_type=local; circuit_code=1
translate trunk; tgn-id=2; carrier_id=288;
```

TNS Routing Modification

TNS routing is modified to enable the setting of `call_type` in the `call_data`. If `setup.ind` has a valid `call_type` the `calldata.call_type` is set to the value derived from `setup.ind`.

The Circuit Code Policy has been added to enable routing based on the circuit code. Additionally, the Call Type Policy has been added to enable routing based on the call type. Both policies can be configured and chained together.

[Figure 3-9](#) and [Figure 3-10](#) illustrate the two possible ways in which the carrier code policy can be configured. [Figure 3-9](#) shows configuration of Circuit Code Policy that enables routing to a different network path based on the Circuit Code. In [Figure 3-10](#), the Call Type policy precedes the Circuit Code policy.

Figure 3-9 Circuit Code Policy

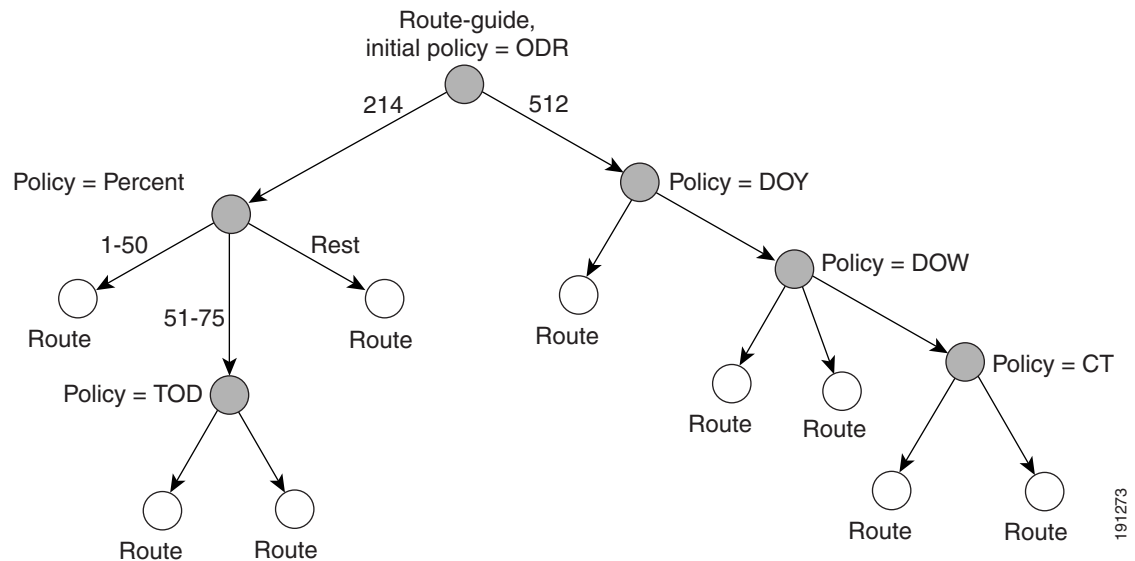
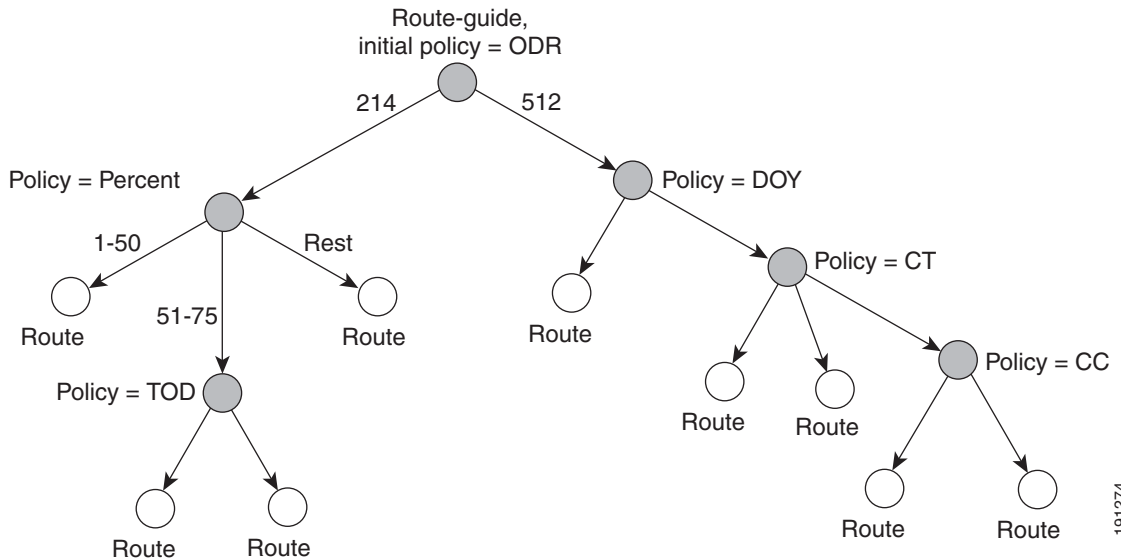

Figure 3-10 Call Type Policy and Circuit Code Policy Combination



191274

Default Routing

Default routing is accomplished by using the new data field `DEFAULT-DEST-ID` in dial-plan-profile.

Use the following example to configure a default route.

```
change/add dia-plan-profile default_dest_id=dest1
```

This command routes a call to default_dest “dest1”.

Validation Digits and Finding Call Type with LERG Data

The LERG data from Telcordia is used to validate the called party digits and to find call type based on the new dial-plan profile field `LERG_SUPP` values. If the value is `VALIDATE_AND_CALLTYPE`, the LERG data is used to validate the Called Party digits and call type evaluated based on the LERG entry. If the value is `USE-TO-VALIDATE-ONLY`, the LERG data is used to validate Called Party digits and call type is derived from the default-destination. If the value is none, the LERG table is not looked at. The `NANP-STATE` table is used to determine if the call_type is `INTL_WZ1` based on the state of the called party.

[Figure 3-11](#) shows the validation of digits using LERG. [Figure 3-12](#) shows the analysis of the call type using LERG.

Figure 3-11 Validating Digits Using LERG Data

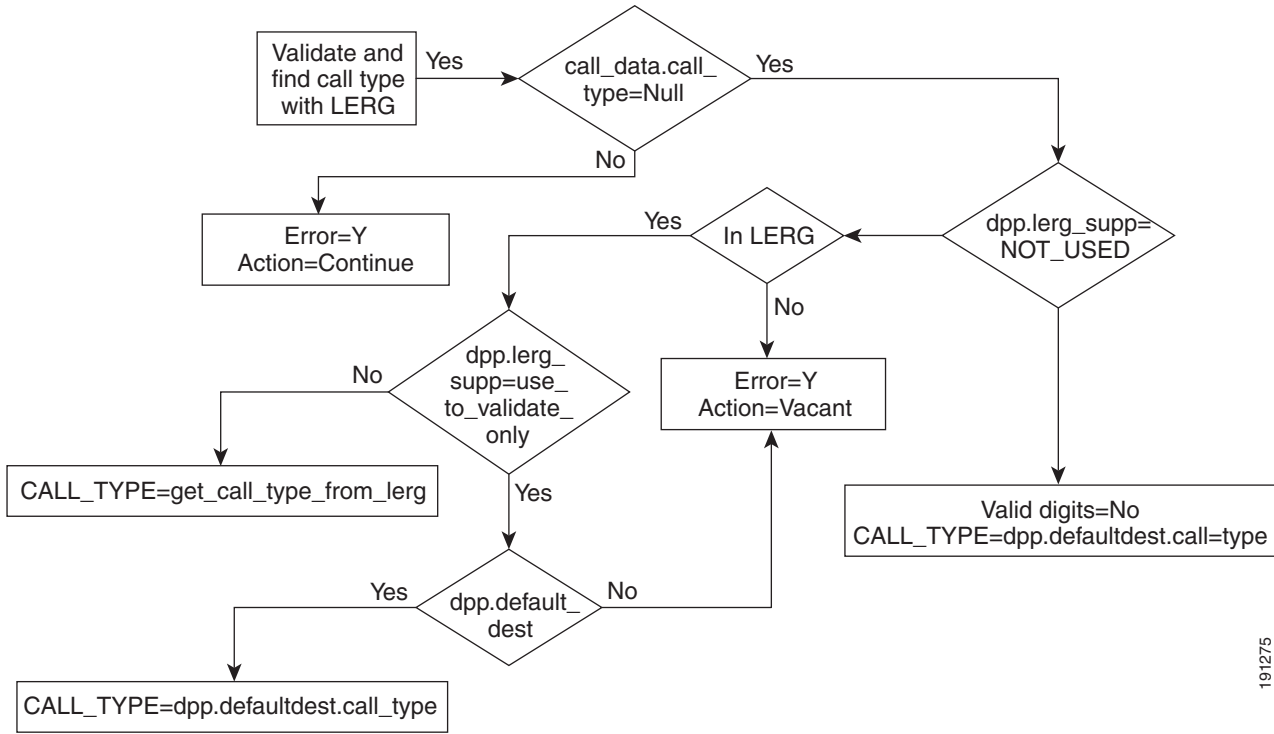

191275

Figure 3-12 Call Type Analysis with LERG Data

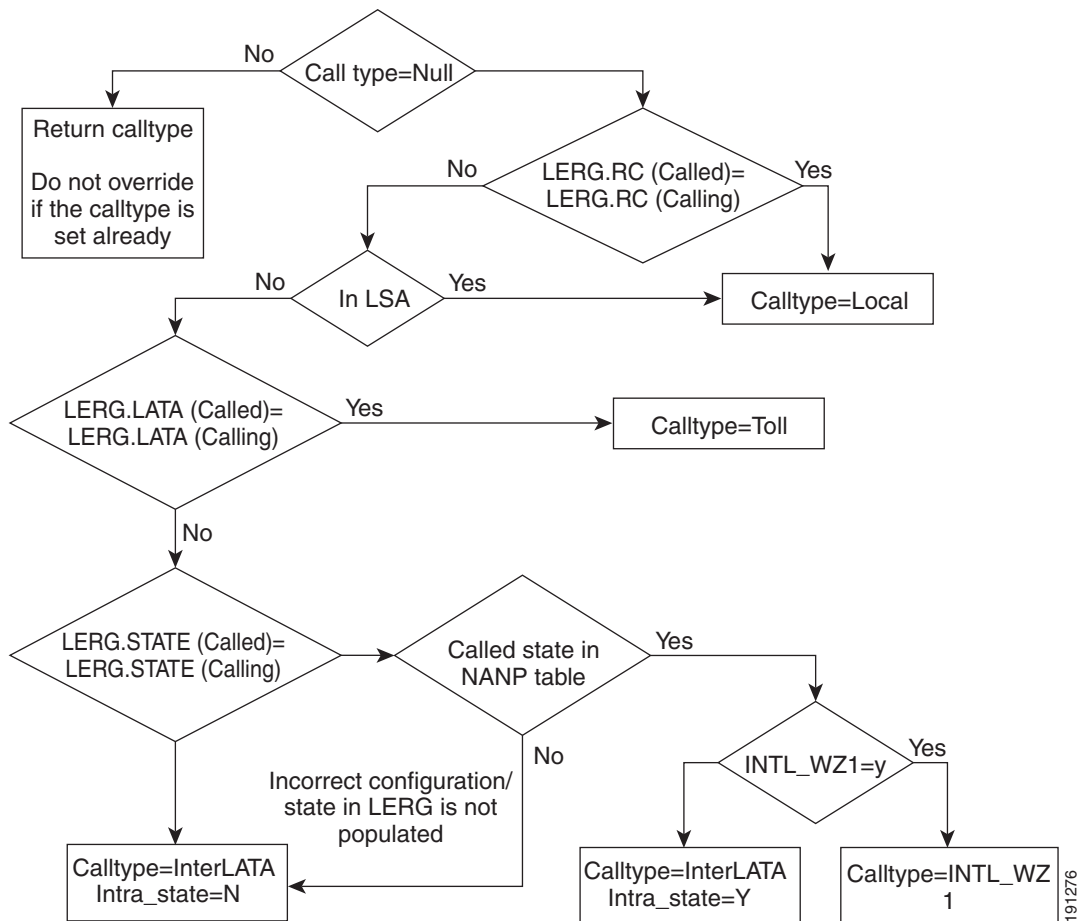

Circuit Code Policy Routing

Circuit code policy routing enables route selection based on the Circuit Code from the TNS parameter.

Call Type Policy Routing

Call type policy routing enable the Cisco BTS 10200 to route calls based on the call type in scenarios like LNP and TOLL_FREE calls. In the case of TOLL_FREE or LNP query scenarios, the call type obtained before the query must be preserved by the BCM. The preserved pre-query call type and the new CALLTYPE policy are used to route the call. This enables the service provider to route the translated call to different trunk groups based on the pre-query call type. [Figure 3-13](#) and [Figure 3-14](#) illustrate the processing and routing of LNP and TOLL_FREE calls, respectively.

Figure 3-13 Routing of an LNP Call

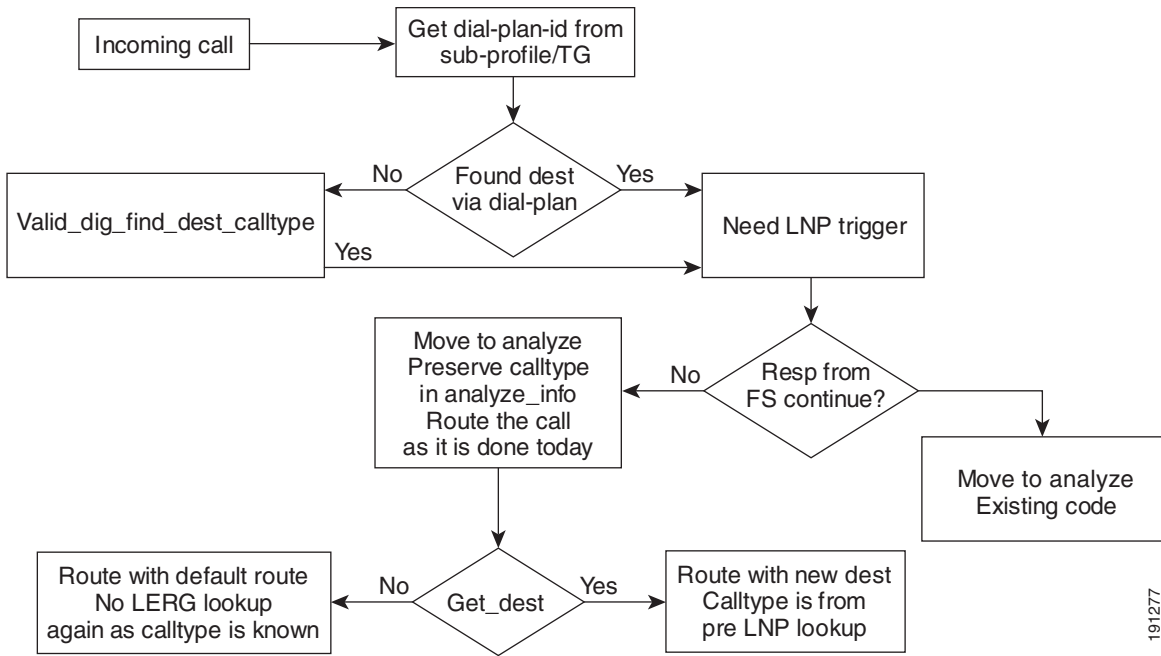
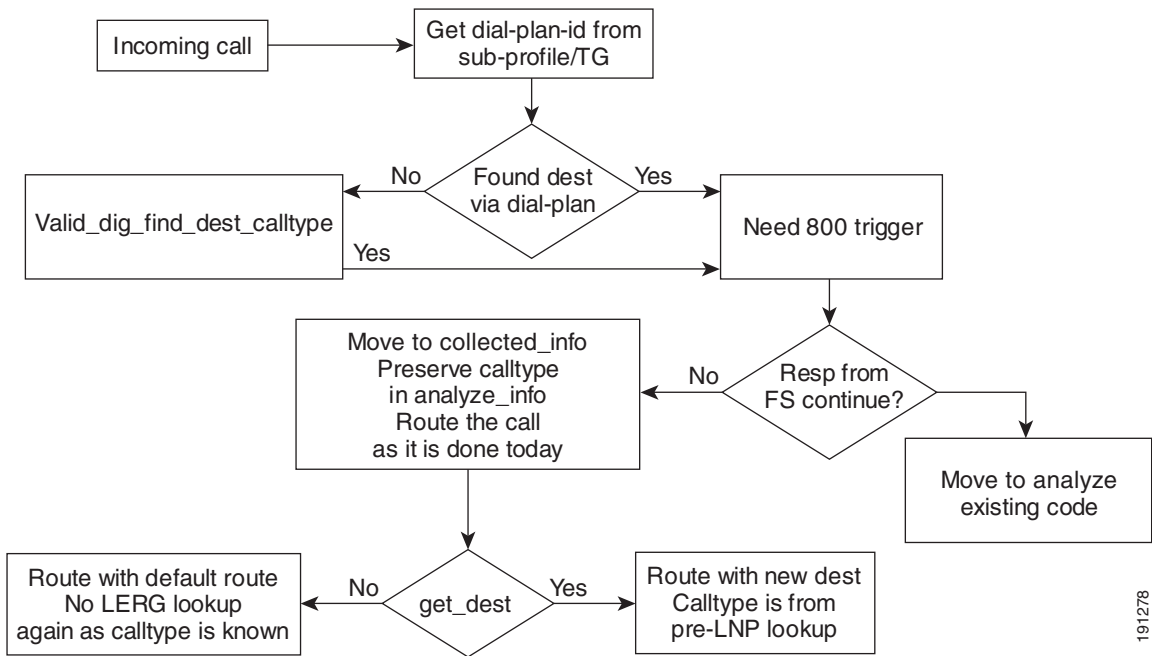

Figure 3-14 Routing of a TOLL_FREE Call



TNS Routing Modifications

No new provisioning is needed for TNS routing modifications. To optimize routing, configure the following to circumvent looking up the dial-plan. For example, when a local call is routed from one CMS to another CMS, then the TG can be configured with a default_dest_id and default_dest_id is configured with Route_TYPE=SUB.

Example:

```
change/add dial-plan-profile id=dp69; default_dest_id=dest1
```

Setting Up LERG Validation and Call_Type

Use the following command to enable LERG data based called party digit validation and call_type.

Example:

```
change/add dial-plan-profile
LERG6_SUPP=NOT_USED/USED_TO_VALIDATE_ONLY/VALIDATE_AND_CALLTYPE
```

Setting Up Call_Type Policy

Use the following examples to configure the call_type policy.

Example:

To add a policy_profile:

```
add policy-profile id=carrier0288; type=ct; default-policy-type=route;
default-policy-id=rt1
```

Example:

To provision a policy_call_type:

```
add policy-call-type id=carrier0288; type=ct; call_type=local; policy_type=cc;
policy_id=CircuteCodePolicy1
```

```
add policy-call-type id=carrier0288; type=ct; call_type=INTL; policy_type=route;
policy_id=rt3
```



Note

Before a policy_call_type entry is added, there must be an entry in policy_profile with TYPE=CTYPE.

Example:

To associate a policy_profile with a route_guide:

```
add route-guide id=rtguide1; policy_type=ct; policy_id=carrier0288
```

Setting Up Circuit_Code Policy

Use the following examples to configure circuit_code policy.

Example:

To add a policy_profile:

```
add policy-profile id=carrier0288; type=cc; default-policy-type=route;  
default-policy-id=rt1
```

Example:

To provision a policy_call_type:

```
add policy-call-type id=carrier0288; type=cc; call_type=local; policy_type=cc;  
policy_id=CircuteCodePolicy1
```

```
add policy_call_type id=carrier0288; type=CC; call_type=INTL; policy_type=route;  
policy_id=rt3
```

**Note**

Before a policy_call_type entry is added, there must be an entry in policy_profile with TYPE=CTYPE.

Example:

To associate a policy_profile with a route_guide:

```
Add route_guide id=rtguide1; policy_type=cc; policy_id=Carrier0288
```

Softswitch Trunk Group Profile Table

The Trunk Group Profile (softsw-tg-profile) table holds all the information specific to a softswitch trunk, such as ID, protocol, indicators, and echo suppression. The softsw-tg-profile record can be shared by multiple softswitch trunk groups. An ID must be created in this table before entries can be added to the Trunk Group table. For token names and description details for the Trunk Group Profile table, refer to the [Cisco BTS 10200 Softswitch CLI Database](#).

North American Numbering Plan Administration State Table

The NANP-STATE table is used to define the states that are INTL-WZ1 states. For token names and description details for the NANP-STATE table, refer to the [Cisco BTS 10200 Softswitch CLI Database](#).

**Note**

The original call type is preserved in billing when the routing number is changed by use of the Policy NXX table.

LERG6 Table

The LERG6 table is used to define the LERG6 tokens and values. For complete LERG6 table details, refer to the [“LERG6 Table” section on page 3-7](#).

Policy Circuit Code Table

The Policy Circuit Code table is used to define the Policy_Circuit_Code tokens and values. For token names and description details for the Policy Circuit Code table, refer to the [Cisco BTS 10200 Softswitch CLI Database](#).

Policy Profile Table

The Policy-Profile Table is used to define ids for Policy Routing. This table also defines the default policy to apply if the next policy to be applied in a sequence is not returned by the Policy Routing table. For token names and description details for the Policy Profile table, refer to the [Cisco BTS 10200 Softswitch CLI Database](#).

Policy Call Type Table

The Policy Call Type table is used to define the Policy Call Type tokens and values. For token names and description details for the Policy Call Type table, refer to the [Cisco BTS 10200 Softswitch CLI Database](#).

Dial Plan Profile Table

The Dial Plan Profile (dial-plan-profile) table creates dial-plan-profile ids before they are assigned to subscribers or trunk groups. The dial-plan-profile id links digit-string entries in the Dial Plan table within a dial plan. Different dial-plan-profile ids are assigned to subscribers and trunk groups. A dial-plan-id must be created in this table before entries can be added to the Dial Plan table. For token names and description details for the Dial Plan Profile table, refer to the [Cisco BTS 10200 Softswitch CLI Database](#).



CHAPTER 4

Electronic Number Mapping and Routing

Revised: December 9, 2008, OL-15637-04

Introduction

This chapter describes electronic number mapping (ENUM) and the ENUM routing capability.

ENUM Capability

ENUM provides a simple query-based mechanism for applications to retrieve data associated with a particular E.164 address. The Cisco BTS 10200 Softswitch supports ENUM queries for on-net routing and LNP data.



Note

See the [Cisco BTS 10200 Softswitch Network and Subscriber Feature Descriptions, Release 6.0.1](#) for a complete list of subscriber features supported by the Cisco BTS 10200.

ENUM Support for Routing

The ENUM Capability feature maps the called DN to the Uniform Resource Identifier (URI) to determine the switch on which the called DN resides. It then routes the call on-net. In order to use this feature, the service provider must deploy private or carrier ENUM servers that hold E.164-to-URI mapping for all DNs owned by the service provider.

Performing the ENUM Query

When receiving a call from a subscriber or from another network element, the Cisco BTS 10200 determines if it is the final destination of the call. If the Cisco BTS 10200 is not the final destination, it performs an ENUM query to determine the destination and obtains the URI to route the call.

The following rules apply to the Cisco BTS 10200 ENUM capability feature:

- The Cisco BTS 10200 launches the ENUM query after it receives the TCAP LNP query results, unless the same ENUM server is configured as LNP capable.
- The Cisco BTS 10200 does not perform ENUM queries for operator calls and casual calls.
- If the service provider does not want to perform ENUM lookup for an NPA-Nxx or wants to use different top-level domains for the ENUM queries based on a different NPA-Nxx, the Cisco BTS 10200 can be controlled on a configuration basis at the destination table level. a

Routing Upon Receipt of the ENUM Response

This section describes the Cisco BTS 10200 routing operation that is based on the response from the ENUM server. In general, responses from the ENUM servers fall into two categories for routing operations:

- The Cisco BTS 10200 receives a URI indicating the final destination of the E.164 number.
- The Cisco BTS 10200 does not receive any URI information.

Call Routing Based on the Received URI

If the called DN is an on-net subscriber (that is, if it is in the VoIP domain), the ENUM server returns the URI associated with the DN, indicating the address of the destination switch that can terminate the call to the subscriber. The Cisco BTS 10200 uses the domain portion of the received URI to determine the on-net path where the call should be routed.

The Cisco BTS 10200 retrieves the domain portion from the returned URI and attempts to find the on-net route configured on the Cisco BTS 10200 (in the domain2route table). For example, if the ENUM query is launched for DN1 and the ENUM response is DN2@btsX.sp.net, the Cisco BTS 10200 ignores the DN2 and uses domain btsX.sp.net to route the call. The Cisco BTS 10200 also uses the same domain in the Req-URI field of the outgoing invite message (for this example, Req-URI is set to DN1@btsX.sp.net).

Because the Cisco BTS 10200 performs a longest match for the received domain with configured routes, service providers may configure only substrings in the domain2route table to keep the number of routing entries to a minimum. For example, the user can configure the Cisco BTS 10200 to use one on-net route for bts10.region1.sp.com and another for region1.sp.com (that is, all Cisco BTS 10200 nodes in region1 except BTS10).

The Cisco BTS 10200 can also specify different policy-based routing features for each domain returned from the ENUM server. For example, Percentage Based Routing and Time of Day Routing can be applied against the domain by specifying ROUTE-TYPE=ROUTE-GUIDE.

The user can also specify multiple routes (that is, multiple softswitch trunks) against the received domain and use the Cisco BTS 10200 Route Advance feature to select an alternate on-net route in case the first on-net route cannot be used to route the call to its final destination.

The Cisco BTS 10200 can use a destination-based route (typically pointing to the PSTN interface, such as an SS7 or SIP trunk group, toward the MGC) for a particular domain received from the ENUM server. This capability can be used in various situations, such as:

- The ENUM server returns the domain of a switch for which a direct IP route does not exist.
- There are no business arrangements for routing the call on-net between two VOIP service providers.

Finally, the Cisco BTS 10200 can block the call based on the received domain. By specifying `ROUTE-TYPE=NO-ROUTE` in the `domain2route` table, this feature can be used in cases where information received from the ENUM server points to the domain of the Cisco BTS 10200 that launched the ENUM query.

Call Routing If the Cisco BTS 10200 Does Not Receive a URI or Receives a No Response message

If the called DN is not an on-net subscriber (is not in the VoIP domain), the ENUM server does not return a URI. The Cisco BTS 10200 performs the existing routing operation and chooses the route specified against the destination (for example, the SS7 route or the SIP route toward the MGC) to send the call towards the terminating switch.

The same behavior applies in the following situations when the Cisco BTS 10200 might not have a URI available to route the call on-net:

- There is no response from the ENUM server within the configured time-limit.
- No match is found for the route specified for the domain returned from the ENUM server.
- The internal Cisco BTS 10200 resources are not available to perform the ENUM query.

ENUM Routing Use Cases

Selecting Inter-CMS Trunks

[Figure 4-1](#) shows a typical Cisco BTS 10200 configuration for deployment to a network without a SIP route proxy. The service provider can create an inter-CMS trunk group and specify the routing policy for a particular route based on the domain portion of the return URI.

Figure 4-1 Inter-CMS Trunks: Network Without SIP Route Proxy

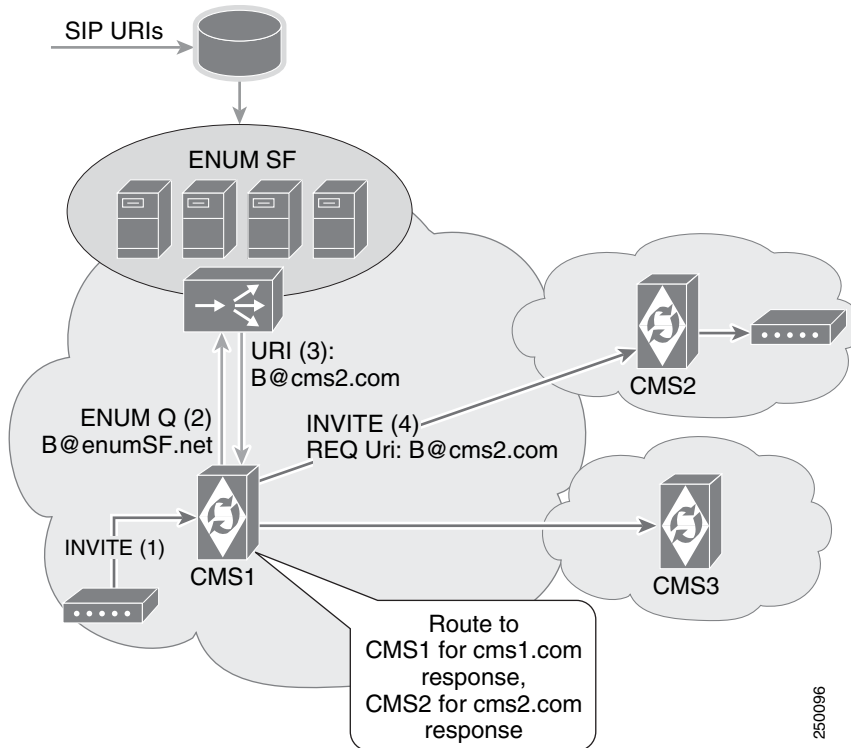

Selecting a SIP Trunk to a Route Proxy

Figure 4-2 shows a typical Cisco BTS 10200 configuration for deployment to a network with a SIP route proxy. The service provider can create one trunk group to go toward the SIP proxy and specify the routing logic for choosing the route, regardless of the domain of the returned URI. The domain portion of the returned URI is used in the Request URI for the outgoing SIP invite. The SIP proxy can direct the calls as appropriate based on this value.

Figure 4-2 Inter-CMS Trunks: Network With SIP Route Proxy

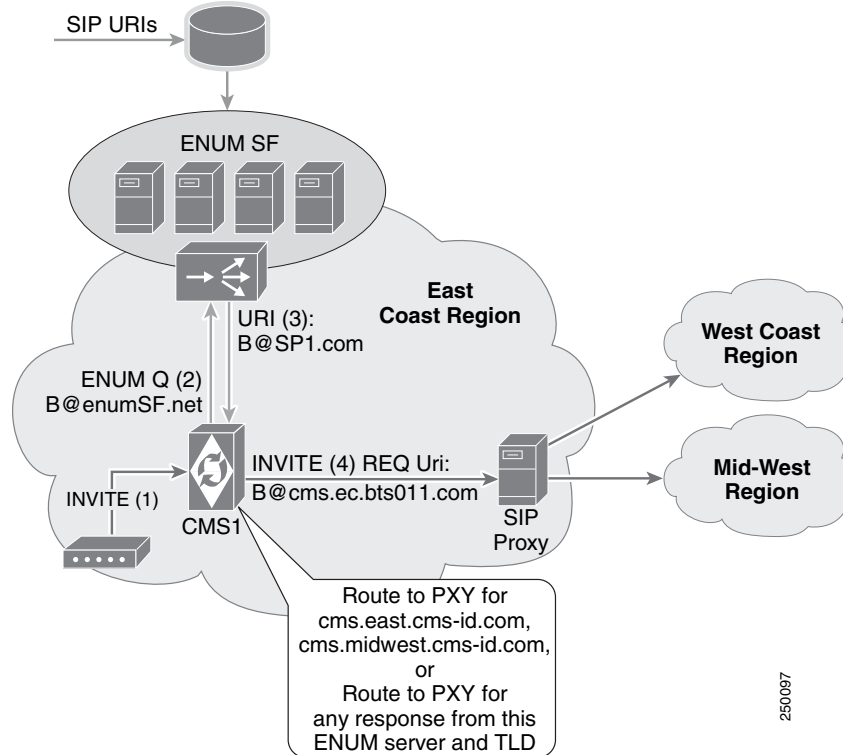

Selecting a SIP Trunk to an SBC

Figure 4-3 shows a typical configuration for routing calls for on-net subscribers in a different service provider domain when a peering arrangement to route on-net calls is established. A service provider typically uses a session border controller to route calls to or receive calls from a different service provider.

The service provider can direct one trunk group toward its own Session Border Controller (SBC) and specify the routing logic so it chooses a particular route, regardless of the domain in the returned URI. The domain portion of the returned URI is used in the Request URI for the outgoing SIP invite. The SBC can direct the calls as appropriate.

Figure 4-3 Routing a SIP Trunk to an SBC

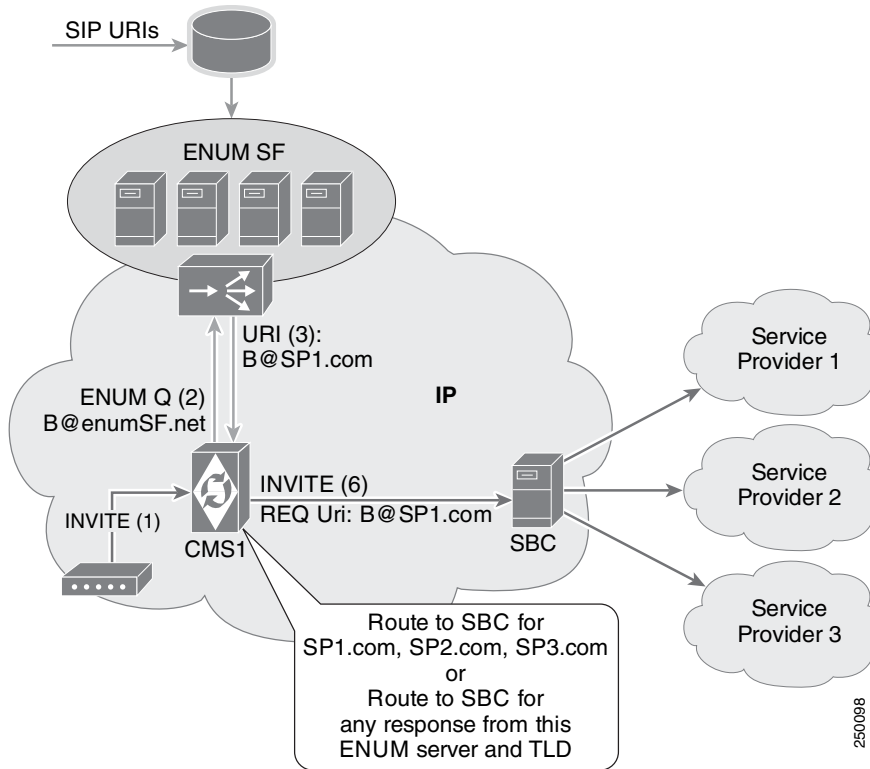

ENUM Support for LNP Data

The Call Management Server (CMS) typically retrieves LNP information by sending a TCAP query toward a Signaling Control Point (SCP) database. RFC 4769 specifies another approach in which similar information can be specified in the ENUM server (E2U+PSTN NAPTR records) and retrieved through an ENUM query rather than a TCAP query. The Cisco BTS 10200 allows the user to disable the TCAP query mechanism and retrieve LNP information using the ENUM query mechanism.

The Cisco BTS 10200 retrieves the E2U+PSTN records from the ENUM server when LNP criteria match and LNP information is required.



Note

The Cisco BTS 10200 will not use the domain portion specified against the rn field in the E2U+PSTN record for on-net routing described above. The Cisco BTS 10200 retrieves only the npdi flag (if available) and the user part of the rn field in the E2U+PSTN record.

Cisco BTS 10200 Routing Operations

The Cisco BTS 10200 uses the Local Routing Number (LRN) as well as the URI to make routing decisions. The following subsections describe the Cisco BTS 10200 routing. That behavior depends on information received by the Cisco BTS 10200 from the ENUM server.

Cisco BTS 10200 Receives the NPDI Indicator and LRN Information

The following table specifies the conditions that occur when the Cisco BTS 10200 receives the Number Portability Dip Indicator (NPDI) and LRN information:

If...	...Then
The URI is not available to the Cisco BTS 10200,	The Cisco BTS 10200 performs the routing operation based on the LRN. In addition, the Cisco BTS 10200 includes the NPDI indicator and LRN in the outgoing IAM/invite message.
The received LRN is for the same switch,	The Cisco BTS 10200 attempts to terminate the call to the subscriber.
The received LRN is a cluster LRN,	The Cisco BTS 10200 attempts to use the cluster dial plan routing to route the call.

Cisco BTS 10200 Receives Only Npdi Indicator

The Cisco BTS 10200 performs the routing operation based on the URI (if available) or the destination table. In addition, the Cisco BTS 10200 includes the NPDI indicator in the outgoing IAM/invite message to indicate that the LNP query is already performed.

Cisco BTS 10200 Receives the NPDI Indicator, LRN and URI

The Cisco BTS 10200 always attempts to select SIP routes against the domain portion of the returned URI. However, if no routing policy is specified for the returned domain or the call cannot be routed on-net due to network conditions, the Cisco BTS 10200 tries to route the call based on the LRN information it received.

The user can also configure the Cisco BTS 10200 to use the ENUM functionality to retrieve LNP data but not perform domain-based routing. To do that, the user does not specify a domain-based routing policy.

Operational Recommendations for Porting Procedures

The following sections specify how customers should configure their server when a DN is ported into a VoIP network or ported out from a VoIP network.

Porting In a DN

A DN from a different network, such as a PSTN network, is ported in to the service provider network. During the transition phase

- No update is required in the LNP database.
- No update is required in the on-net routing database.

After porting is complete, the customer should do the following:

- Specify the E2U+SIP records for the ported-in number so all the switches within the VoIP network can use the on-net routing functionality.
- Update the LNP database with the LRN or cluster LRN of the destination switch to which the subscriber is ported. This information is typically used by nodes outside the VoIP domain to route the call.

Porting Out a DN

A DN from the service provider network is ported out on a switch in a different network, such as a PSTN network. During the transition phase

- No update is required in the LNP database.
- No update is required in the on-net routing database.

After porting is complete, the customer should do the following:

- Update the LNP database with the LRN or cluster LRN from the destination switch to which the subscriber is ported out.
- Remove the E2U+SIP records in the ENUM server so all VoIP nodes can use the LRN-based routing functionality.

Porting a DN to a Different Node

If a DN is moved from Node A to Node B within the same service provider network, modifying the E2U+SIP record in the ENUM server is sufficient as long as both nodes share the same LRN or cluster LRN. If the nodes have different LRNs or cluster LRNs, we recommend updating the LNP database so calls that originate in the PSTN network are efficiently routed.

ENUM Clients Operation

This section describes the processing rules for ENUM.

Launching the ENUM query

The Cisco BTS 10200 launches the ENUM query using the E.164 number of another server. The user can specify the top-level domain and predefined digits used for the query before the Cisco BTS 10200 launches the query. Use the following steps to launch the ENUM query.

-
- Step 1** Delete from the digit string as many leading digits as specified by DEL-DIGITS in the ENUM profile, ignoring any leading or intermediate nondigit characters. For example:
- digit string=954048**
DEL-DIGITS=1
Result=54048
- Step 2** Prefix the digits specified by PFX-DIGITS in the ENUM profile to the transformed digit string after any leading nondigits or characters.
- digit string=54048**
PFX-DIGITS=1-469-25
Result=1-469-255-4048
- Step 3** Remove all nondigit characters from the transformed digit string.
- digit string=1-469-255-4048**
Result=14692554048
- Step 4** Insert dots ('.') between the digits of the transformed digit string.
- digit string=14692554048**
Result=1.4.6.9.2.5.5.4.0.4.8
- Step 5** Reverse the transformed digit string.
- digit string=1.4.6.9.2.5.5.4.0.4.8**
Result=8.4.0.4.5.5.2.9.6.4.1
- Step 6** Append the ENUM domain root specified by the TOP_LEVEL_DOMAIN of the ENUM profile to the transformed digit string.

After processing is complete, the Cisco BTS 10200 sends the query to the ENUM server specified in the profile. The Cisco BTS 10200 ENUM client provides the nonblocking querying behavior to the applications

Filtering the Response

After receiving the response from the ENUM server, the Cisco BTS 10200 extracts the URI used for on-net routing, according to the specifications in RFC 3761. The following steps describe how the Cisco BTS 10200 automatically filters the response.

-
- Step 1** All NAPTR records in which the service field does not match the requested service are ignored.
- Step 2** All nonterminal NAPTR records (those records in which the flags field is not u) are ignored.
- Step 3** The remaining NAPTR records are sorted based on the order field (in decreasing order) and the preference field (in increasing order).

- Step 4** All NAPTR records in which the regexp field contains malformed regular expressions are ignored.
- Step 5** The NAPTR record at the top of the list sorted in Xref_Colorparanum is selected.
- Step 6** The regular expression rules specified in the regexp field are applied to the digit string to obtain a URI.
- Step 7** The required information is extracted from the URI. Any malformed URIs are ignored.
- Step 8** One of the following occurs:
- If multiple URIs are present, the first in the list is used. Because the list has been sorted, the first in the list has priority.
 - If only one URI is present, it is used for on-net routing.
 - If no URIs are present, the DN is considered off-net and the call is routed using other routing rules.

Supporting Multiple Roots

The Cisco BTS 10200 can launch multiple ENUM queries toward the same set of ENUM servers or to a different set for the same call using different top-level domains. You can use this function when information for on-net subscribers is located in multiple ENUM servers, as when there is a carrier ENUM in addition to a private ENUM.

Figure 4-4 shows how the Cisco BTS 10200 supports multiple roots. In this example, it is configured to send an ENUM query to a private ENUM server farm. The private ENUM server farm responds with no record found. With the appropriate configuration, the Cisco BTS 10200 launches the query to the carrier ENUM server farm with a different top-level domain configured against the ENUM profile of carrier ENUM servers.

Figure 4-4 ENUM Queries for Multiple Roots

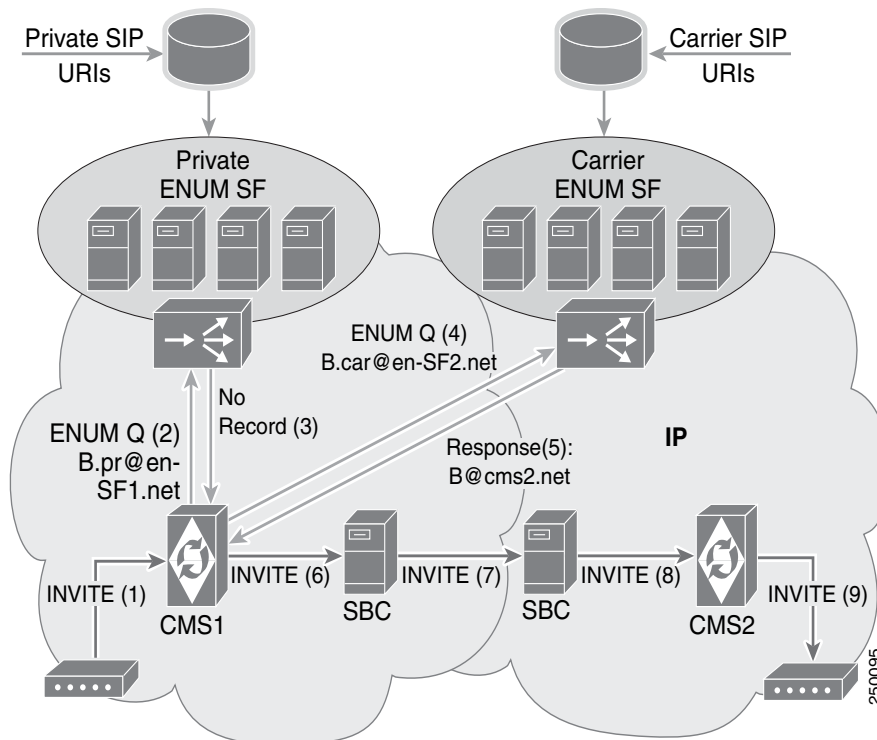

Supporting Multiple ENUM Servers

The Cisco BTS 10200 can interface with multiple ENUM servers or server farms from which it retrieves data from the SRV records. It can also distribute the ENUM queries with a round-robin or priority order policy. The following procedure describes how the Cisco BTS 10200 retrieves data from the SRV records.

-
- Step 1** Send an SRV query to the default DNS server for the logical service name obtained from the ENUM_SERVER_DOMAIN field specified in the ENUM profile table.
- Step 2** Obtain and compile a list of servers from the target field of each SRV record returned by the query.
- Step 3** Send an A query to the default DNS server for each server obtained in the previous steps.
- Step 4** Obtain and compile a list of ENUM server IP addresses associated with each server in the A records returned by the query.

The cached IP addresses are reached at predefined intervals specified in the ENUM_SERVER_DOMAIN_TTL field in the ENUM profile. The query retrieves all changes in network configuration or query distribution policy.

Monitoring ENUM servers and Measuring Latency

The Cisco BTS 10200 uses the actual ENUM queries and test queries to monitor the status of each ENUM server. The Cisco BTS 10200 sends a test query to an ENUM server if no actual ENUM queries are sent to that server during the period specified by the TEST-QUERY-INTERVAL parameter in the ENUM profile table. The test query used to monitor the status of an ENUM server is an NAPTR query.

The Cisco BTS 10200 uses the following logic to update the ENUM server availability status.

- If three consecutive queries (including test queries) time-out or indicate the server is unavailable, the Cisco BTS 10200 marks that ENUM server as unavailable.
- If it receives three consecutive test query responses from an ENUM server that has been marked as unavailable, the Cisco BTS 10200 marks that ENUM server as available.

The Cisco BTS 10200 calculates the round-trip delay for each ENUM and test query to determine the average latency associated with the ENUM server.

The Cisco BTS 10200 uses the latency and availability parameters to select the ENUM server to which the next ENUM query should be sent.

Prerequisites

The service provider must deploy a private or carrier ENUM server to make use of ENUM functionality on the Cisco BTS 10200. In addition, if the ENUM LNP feature is used, the same ENUM server must be configured with E2U+PSTN records for all ported DNPs.



CHAPTER 5

Dial Plans and Routing

Revised: December 9, 2008, OL-15637-04

Introduction

This chapter provides detailed dial plan and routing information for the Cisco BTS 10200 Softswitch. The following subjects are discussed in this chapter:

- [Originating Basic Call State Machine \(CS2 Call Model\)](#)
- [Cisco BTS 10200 Feature Server Strategy](#)
- [Point of Presence](#)
- [Network Configuration](#)
- [Subscriber Types](#)
- [Digit Collection](#)
- [Dial Plans](#)
- [Digit Manipulation](#)
- [Digit Analysis](#)
- [Class of Service Screening](#)
- [Routing](#)
- [Trunk Group Types](#)
- [Generic Address Parameter Based Routing](#)
- [Tandem Provisioning](#)
- [Local Toll-Free Service Provisioning](#)
- [Carriers and Service Providers](#)
- [Carrier Based Routing](#)
- [Call Processing Flow](#)



Note

When a customer is temporarily disconnected, all calls except 911 calls are routed to the customer support number.

Originating Basic Call State Machine (CS2 Call Model)

This section provides detailed information on the partial originating basic call state machine (OBCSM). Refer to [Figure 5-1](#) and review the following explanation of the CS2+ call model.

1. 0 null - Off hook condition – Call setup begins.
2. Origination attempt decision point. Hot line feature information and denied origination information is obtained from the feature server.
3. Authorize origination attempt.
4. Origination attempt authorized decision point. Provide dial tone and request digits.
5. Collect information. Digits information or timeout information is provided.
6. Collected information decision point. Warm line feature information and speed calling information are obtained from the feature server.
7. Analyze information. Public dial plan only information, prefix analysis information, no “A” determination information, and destination identified information are obtained from the translation server.
8. Analyzed information decision point. Local number portability information and 800 service information are obtained from the feature server. The service control point provides the vertical services, class of service (CoS) screening, and customized dialing plan information.
9. Select route. The carrier-based information and routing address information are provided by the routing server.
10. Authorize call setup.

Figure 5-1 Originating Basic Call State Machine (CS2 Call Model)

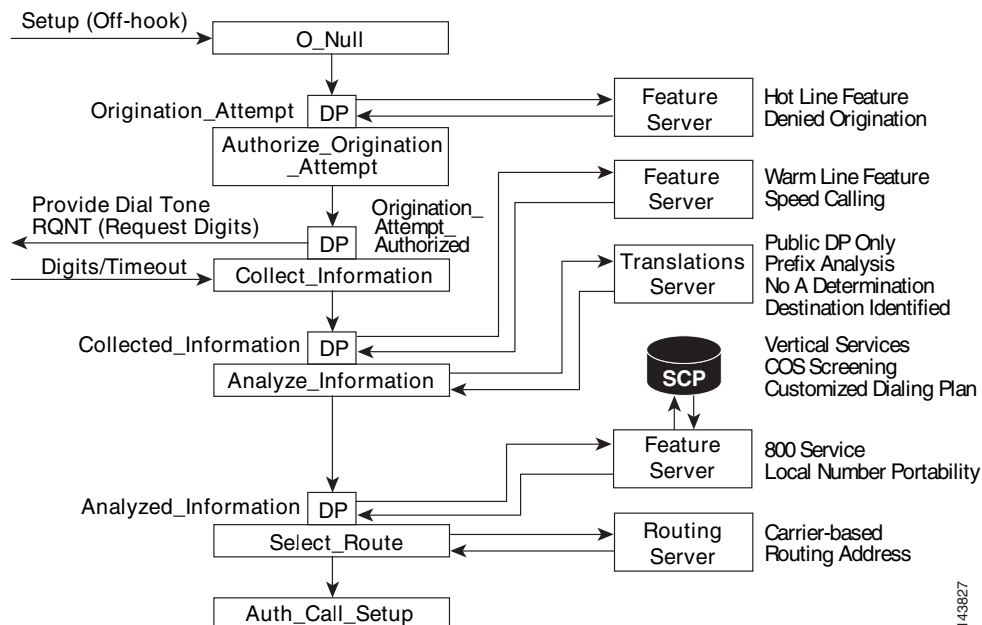

Cisco BTS 10200 Feature Server Strategy

Figure 5-2 provides an illustrated example showing the Cisco BTS 10200 feature service strategy.

Figure 5-2 Cisco BTS 10200 Feature Server Strategy

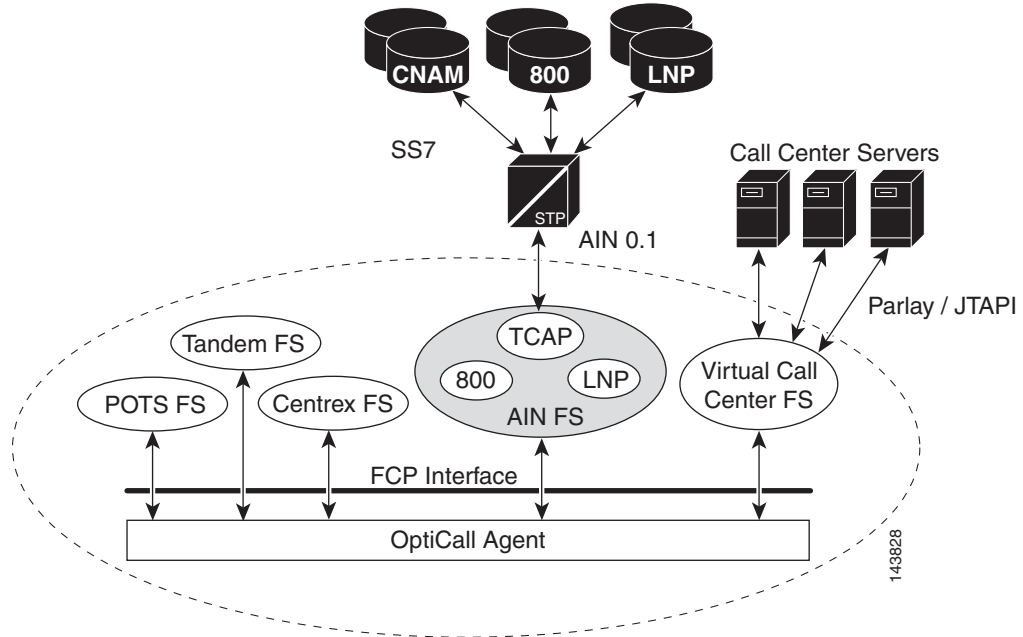

Point of Presence

Figure 5-3 provides an illustrated example of the Cisco BTS 10200 ability to process and route calls between multiple points of presence (POPs).

Figure 5-3 Processing and Routing Calls Between Multiple Points of Presence

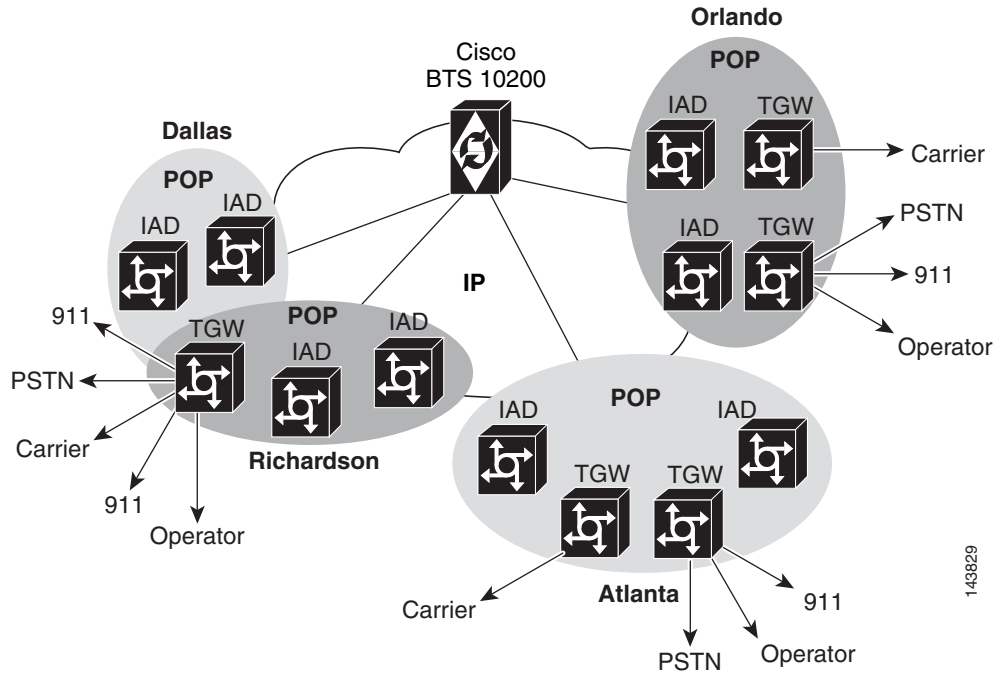

Network Configuration

Figure 5-4 provides an illustrated example of a typical Cisco BTS 10200 network configuration.

Figure 5-4 Network Configuration

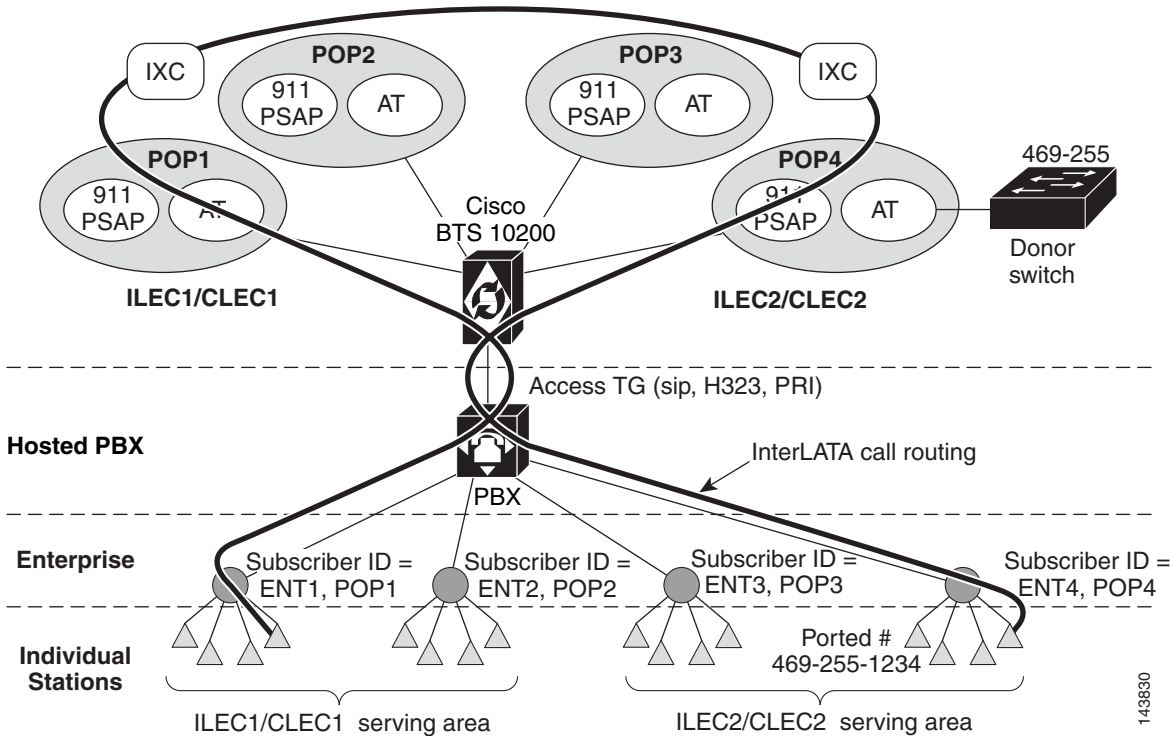

Subscriber Types

This section describes the Cisco BTS 10200 subscriber types. The following subjects are discussed:

- [Individual](#)
- [Centrex](#)
- [Interactive Voice Response](#)
- [Multi-line Hunt Group](#)
- [Private Branch Exchange](#)
- [Remote Activation of Call Forwarding](#)

Individual

The individual subscriber type is assigned to subscribers by default.

Centrex

The Centrex (CTX) subscriber type is assigned to the main subscriber ID of a Centrex group. Additionally, Centrex subscribers types include CTXG-INDIVIDUAL subscribers, CTXG-MLHG subscribers, and CTXG-TG subscribers. The CTXG-INDIVIDUAL subscriber type is assigned to a Centrex subscriber. The CTXG-MLHG subscriber type is assigned to a Centrex Multi-line Hunt Group (MLHG) (for example, attendant). The CTXG-TG subscriber type is assigned to a Centrex trunk group.

Interactive Voice Response

The interactive voice response (IVR) subscriber type is assigned access to a DN for IVR.

Multi-line Hunt Group

The MLHG subscriber type is assigned to the main subscriber ID of a MLHG. Additionally, MLHG subscriber types include MLHG-INDIVIDUAL subscribers and MLHG-PREF-INDIV subscribers. The MLHG-INDIVIDUAL subscriber type is assigned to a subscriber within an MLHG. The MLHG-PREF-INDIV subscriber type is assigned to the main subscriber ID of a preferential hunt list.

Private Branch Exchange

The private branch exchange (PBX) subscriber type is assigned to the main subscriber ID of a PBX.

Remote Activation of Call Forwarding

The remote activation of call forwarding (RACF) subscriber type is assigned to a DN for remote activation of call forwarding.

Digit Collection

The Digit Map (digit-map) table tells a media gateway (MGW) how to collect and report dialed digits. The Call Agent uses a default digit-map id for normal digit collection unless a specific digit map ID is assigned to the subscriber. There are two types of subscribers:

- Plain old telephone service (POTS) (individual/residential)
- Centrex (business group)

POTS subscribers use a public dialing plan. Centrex subscribers use a customized dialing plan.

Customized dialing plan example:

```
add digit-map id=default;
digit-pattern=0T|00|[2-9]11|[2-9]xx[2-9]xxxxxx|1[2-9]xx[2-9]xxxxxx|
0[2-9]xx[2-9]xxxxxx|011xxxxxx.T|01xxxxxx.T|101xxxx|#|*xx|xxxxxxxxxxxxxxxxxxxx;
```

Table 5-1 describes the components of a digit map that is created by issuing the **add digit-map** command.

Table 5-1 Component Breakdown of Add Digit Map Command

Component	Description
0T	Operator call (0-)
00	Carrier operator (00)
[2-9]11	N11 dialing
0[2-9]11	0+N11 dialing (0+911)
1[2-9]11	1+N11 dialing (1+911, 1+411)
[2-9]xx[2-9]xxxxxx	10-digit local in home numbering plan area (HNPA) (972, 973)
1[2-9]xx[2-9]xxxxxx	1+ 10 digit
0[2-9]xx[2-9]xxxxxx	0+ 10 digit
011xxxxxx.T	International direct dial domestic (IDDD), minimum 6 digits
01xxxxxx.T	Operator-assisted IDDD, minimum 6 digits
101xxxx	Casual dialing
#	End of dialing or cut-through
*xx	Vertical service code
xxxxxxxxxxxxxxxxxxxx	Maximum digit string (19 digits=011+16 digits for international call)

Digit-pattern=0T

T starts 4-second timing. But if digits are dialed within that 4 seconds, that digit pattern is skipped. If no digits are dialed within 4 seconds, or the pound sign (#) is pressed, then end-of-dial is assumed and a match occurs with the specified digit pattern. The collected digits are reported to the Call Agent.

Example: 0T indicates that match occurs if user only dials digit 0 (with 4-second time out) or user dials 0#. A # indicates to cancel 4-second timing and report digits immediately.

Digit-pattern=x.T

In this table, T also starts 4-second timing. The dot represents any number of digits. The gateway keeps collecting digits until either 4 seconds elapse between digits or until the pound sign (#) is pressed.

For additional digit collection information, refer to the [Cisco BTS 10200 Softswitch CLI Database](#).

Dial Plans

The following topics are discussed in this section:

- [National Dial Plan](#)
- [International Dial Plan](#)
- [Custom Dial Plan](#)

National Dial Plan

The national dial plan analyzes, screens, and routes calls based on dialed digits. The National Dial Plan table holds dial plan information for a specific type of call. It defines valid dialing patterns and determines call routing. All records that share a common dial-plan-profile id are considered a dial plan.

The national call type allows the Call Agent to consolidate multiple dial plans into a Master Dial Plan. All destination IDs can be provisioned with the same `CALL TYPE=NATIONAL`. (A Non Conforming Equal Access End Office can also use this call type.) The following tables are needed for proper Call Type determination:

- Local service area (LSA)
- LATA (LATA attributes)
- LATA-MAP (convert digit-string to LATA)

Call Processing first checks if the called number appears in the LSA table. If it appears in the LSA table, the call type is changed to *local*.

If the LATA tables are populated, call processing reads the calling LATA and called LATA tables. If the LATA values are the same, the call type is converted to *toll*. If the LATA values are different, the call type is converted to *interLATA*.

Call processing also compares the state values from the calling LATA and called LATA tables. If the state values match, the call is intrastate; otherwise, the call is interstate.

**Note**

As the name implies, you should use only the *national* call type domestic NPA/NXX. Call processing does not convert the call type to *intl* if the LATAs are in different countries.

International Dial Plan

The International Dial Plan (`intl-dial-plan`) table holds international dial plan information for calls to regions outside the NANP. It contains the country code, minimum and maximum digits, the country name, and the route-grp-id.

Variable Digit Dialing

Variable digit dialing is used in Europe where the length of the dialed number can vary from seven digits to ten digits, mainly in Germany. For a given NDC or EC, the DN can vary from the minimum to the maximum specified in the Exchange Code table.

Example:

```
ndc=349, ec=234; min-digits=7; max-digits=10; (from the Exchange Code table)
```

DN=3492340 could be a DN

DN=3492341234 could also be a DN belonging to ndc=349, ec=234

DN=349234222 could also be a 9 digit DN

Variable Digit Dialing Provisioning

To provision variable digit dialing according to the example given in “[Variable Digit Dialing](#)” section, take the following steps:

```
add exchange-code ndc=349, ec=234; min-digits=7; max-digits=10;
```

```
add office-code ndc=349; ec=234; dn-group=0; (For the DN=3492340)
```

```
add office-code ndc=349; ec=234; dn-group=1xxx; dn-length= 10; (For the 10 digit DNs)
```

```
add office-code ndc=349; ec=234; dn-group=2xx; (For the 9 digit DNs in the dn group)
```

```
add office-code ndc=349; ec=234; dn-group=12x; (For the 9 digit DNs)
```

Custom Dial Plan

The Custom Dial Plan (custom-dial-plan) table translates Centrex calls. If the result of a custom dial plan (CDP) is a POTS access code, call processing uses the POTS Dial Plan table to translate the digits dialed after the POTS access code. Speed call codes are provisioned in this table as NOD=SPEED-CALL and FNAME=SC1D (or SC2D). Screening does not apply to speed dialing.

Digit Manipulation

The Digit Manipulation (digman) table is used to perform digit and NOA manipulation. Examples of digit manipulation are:

- Blind delete and prefix capability (delete 3, prefix 972)
- Based on string comparison (replace ^972 with NULL)
- Based on string length (if 7 digits, prefix with 972)
- Pattern matching (if 469255, replace with 5)
- Nature of address (if NOA=subscriber, prefix with 972)

Digit Analysis

This section contains information related to dialed digit analysis. Dialed digit analysis determines the destination and routing of the placed call. The following topics are discussed:

- [Destination](#)
- [Local Service Area](#)

Destination

This section contains information related to the placed call destination determination. The following topics are discussed:

- [Call Type](#)
- [Route Guide](#)
- [Route](#)
- [Carrier](#)

Call Type

The Call Type (call-type) table contains the valid call types supported by the Call Agent. It is not provisionable. For additional information on call types, refer to [Appendix A, “Call Types and Subtypes.”](#)

Route Guide

The Route Guide (route-guide) table holds routing information based on policy-type.

Route

The Route (route) table contains a list of up to ten trunk groups to route a call. If all the trunk groups are busy or not available, call processing uses the alt-route-id (if specified) to route the call. The Element Management System (EMS) provisions the Call Agent ID field based on the Trunk Group table.

**Note**

This table allows the service provider to provision a list of up to 10 trunk groups (TG1 to TG10), and a parameter for selecting the priority of the TGs for routing (TG-SELECTION). The system attempts to route the call on the highest priority TG. If the call cannot be completed on the highest priority TG, the system attempts to use the next (lower priority) TG, a process known as route advance. The system attempts route advance to lower priority TGs up to five times. (Any TG in the list that is administratively out of service is not counted as an attempt.) If all five attempts fail, the call is released, and the system provides a release announcement.

Carrier

The Carrier (carrier) table defines the characteristics and capabilities supported by interLATA carriers, intraLATA carriers and international carriers, and provides routing information. For token names and description details for the Carrier table, refer to the [Cisco BTS 10200 Softswitch CLI Database](#).

The following conditions apply when route-guide-id in the Carrier table is configured for a toll-free call:

- When a subscriber makes the call, the route-guide-id in the Carrier table is used to route the call if SCP returns a carrier ID.
- When SS7 makes a toll-free call, the route-guide-id in the Carrier table works only when traffic-type=tandem if SCP returns a carrier id. This is because that toll free call query normally happens at either a local switch made by a local user or at a tandem switch where the traffic type should be set to tandem.

When a subscriber makes a call to an interLATA number, the Cisco BTS 10200 routes the call via the interLATA carrier (PIC1) assigned to the subscriber. The call is then routed via the route guide ID provisioned in the Carries table. If the Service Provider (SP) is also providing the long distance service, the SP can make use of the USE-DIAL-PLAN token in the Carrier table. When USE-DIAL-PLAN flag is set in the Carrier table, the Cisco BTS 10200 bypasses the carrier routing and instead routes the call based on the route specified in the Destination table.

If the NPA-NXX-(X) of the dialed number is defined in the Ported Office Code table and the dialed number is not defined locally on the Cisco BTS 10200, then the Cisco BTS 10200 launches an LNP query. If the LNP query returns an LRN, the call is routed based on the LRN. Otherwise, the call is routed based on the route specified in the Destination table for the original dialed number. If policy based-routing is required, the Destination table is provisioned with the ROUTE-GUIDE-ID. Otherwise, it is provisioned with a ROUTE-ID.

Table 5-2 shows how the USE-DIAL-PLAN token in the Carrier table impacts routing.

Table 5-2 Impact of the USE-DIAL-PLAN Token on Routing

Type of Call	USE-DIAL-PLAN=Y	USE-DIAL-PLAN=N
NAT 1+ Call	Route based on dial plan.	Route based on Carrier table.
OPR 101XXXX+0-, 00 Operator Call	Based on EA-USE-PIC1 flag in the Subscriber Profile table. If the EA-USE-PIC1 flag is set to N, the call is routed to the LECOSS; otherwise, use PIC1. If a Carrier supports operator services, use the route guide defined in the Carrier table; otherwise, use LECOSS-RG.	Same as USE-DIAL-PLAN=Y.
NAT-OPR (101XXXX) 0+ call	Based on EA-USE-PIC1 flag in the Subscriber Profile table. If the EA-USE-PIC1 flag is set to N, the call is routed to the LECOSS; otherwise, use PIC1. If a carrier supports operator services, use the route guide defined in the Carrier table; otherwise, use LECOSS-RG.	Same as USE-DIAL-PLAN=Y.
SAC SAC call (500, 700, 900)	Route based on dial plan.	Route based on Carrier table.
DA Directory assistance (DA, DA-TOLL)	Route based on dial plan.	Route based on Carrier table.
TOLL-FREE Toll-free call (8XX)	Route based on dial plan.	Route based on Carrier table.

Table 5-2 *Impact of the USE-DIAL-PLAN Token on Routing (continued)*

Type of Call	USE-DIAL-PLAN=Y	USE-DIAL-PLAN=N
INTL (101XXXX) 011+ International call	Route based on international dial plan.	Route based on Carrier table.
INTL-OPR (101XXXX) 01+ international operator call	Based on EA-USE-PIC1 flag in the Subscriber Profile table. If the EA-USE-PIC1 flag is set to N, the call is routed to the LECOSS; otherwise, use PIC1. If a Carrier supports operator services, use the route guide defined in the Carrier table; otherwise, use LECOSS-RG.	Same as USE-DIAL-PLAN=Y.
CUT-THRU 101XXXX+#	Use Carrier information; use the route guide defined in the Carrier table.	Same as USE-DIAL-PLAN=Y.
COIN/Hotel-Motel Coin line (OLI=23, 27, 70) Hotel motel line (OLI=6)	Treated as an operator call. If a Carrier supports operator services, use the route guide defined in the Carrier table; otherwise, use LECOSS-RG.	Same as USE-DIAL-PLAN=Y.

Local Service Area

The Local Service Area (LSA) table provides extended local service. If a NANP-dialed call results in an intraLATA toll or an interLATA call, and the subscriber has an LSA ID assigned, the LSA table is screened to check if the dialed digits appear in the subscriber's LSA area. If the dialed digits are found in the LSA table, the call is converted to a local call.

Class of Service Screening

Class of service (CoS) screening allows subscribers, or a group of subscribers, to have different collections of privileges and features assigned to them.

The CoS Restrict (cos-restrict) table identifies the restrictions on a subscriber's class of service, including restrictions on the calls the subscriber can make (screening).

Call type and casual call screening are not performed for NANP and international operator calls, even though NANP or casual call restrictions are requested for a calling party.

Account codes are not collected for:

- 0+, NANP operator calls
- 01+, international operators calls
- Local calls

Class of call screening examples are:

- Block based on call types (900, 411, operator)
- NANP restrictions based on call type (local, intraLATA, national, or all NANP)
- International restrictions (all CC, none, B/W list)
- Casual call restrictions (no restrictions, no casual calls, B/W list)
- Originating line information (OLI) restrictions for tandem calls
- Account codes
- Authorization codes

Routing

This section provides information relating to the routing of calls by the Cisco BTS 10200. The following topics are discussed:

- [Office Code](#)
- [Ported Office Code](#)
- [Route Guide](#)
- [Route](#)
- [Trunk Group](#)

Office Code

The Office Code (office-code) table specifies the office codes assigned to a particular Call Agent. The office codes defined in this table normally terminate to a subscriber. This table defines the office-code-index (normalized office code) that is used as an index in the DN2Subscriber table.

Ported Office Code

The Ported Office Code (ported-office-code) table specifies numbers, or ranges of numbers, that might have been ported-in to this switch. If a called number matches any of the ported numbers, or is within any of the specified ranges of numbers, the Call Agent queries the DN2subscriber table to determine the current status of the DN.

Route Guide

The Route Guide (route-guide) table holds routing information based on policy-type.

Route

The Route (route) table contains a list of up to ten trunk groups for call routing. If all the trunk groups are busy or not available, call processing uses the alt-route-id (if specified) to route the call. The EMS provisions the Call Agent ID field based on the Trunk Group table.

**Note**

The Route table allows the service provider to provision a list of up to 10 trunk groups (TG1 to TG10), and a parameter for selecting the priority of the TGs for routing (TG-SELECTION). The system attempts to route the call on the highest priority TG. If the call cannot be completed on the highest priority TG, the system attempts to use the next (lower priority) TG, a process known as route advance. The system attempts route advance to lower priority TGs up to three times. (Any TG in the list that is administratively out of service is not counted as an attempt.) If all three attempts fail, the call is released, and the system provides a release announcement.

The Route table enables:

- 10 trunk groups per route
- Digit manipulation per trunk group
- Linking of multiple routes

Trunk Group

The Trunk Group (trunk-grp) table identifies the trunk group and maps it to the associated media gateway.

Trunk Group Types

The Cisco BTS 10200 supports the following trunk group types: announcement, channel associated signaling (CAS), Integrated Services Digital Network (ISDN), Signaling System 7 (SS7), and SOFTSW (Session Initiation Protocol (SIP)). The Trunk Group table defines common information based on the trunk group type. The Cisco BTS 10200 supports announcement, CAS, ISDN, SS7 and SOFTSW trunk group profiles. The following trunk group types are discussed:

- [Announcement](#)
- [Channel Associated Signaling](#)
- [Integrated Services Digital Network](#)
- [Signaling System 7](#)
- [Session Initiation Protocol](#)

Announcement

The Announcement Trunk (annc-trunk) table is used when an announcement server is required in an Asynchronous Transfer Mode (ATM) network.

Channel Associated Signaling

The CAS Trunk Group Profile (cas-tg-profile) table holds common information on a CAS trunk group. It supports the following signaling types: dual tone multifrequency (DTMF) loop start, DTMF ground start, multifrequency (MF) im start, MF wink start, DTMF im start, DTMF wink start. A cas-tg-profile record can be shared by multiple CAS trunk groups.

Integrated Services Digital Network

The ISDN Trunk Group Profile (`isdn-tg-profile`) table holds common information regarding an ISDN trunk group. This table is used to configure the Cisco BTS 10200 to interact with various types of private branch exchanges (PBXs) having different configurations (such as non-facility associated signaling (NFAS), facility associated signaling (FAS), and so forth), initialization procedures (service or restart), and to support different call control or maintenance timer values. The `isdn-tg-profile` record can be shared by multiple ISDN trunk groups. The table tokens configure the Call Agent to communicate with a particular PBX.

Signaling System 7

The SS7 American National Standards Institute (ANSI) Trunk Group Profile (`ss7-ansi-tg-profile`) table holds common information regarding an SS7 trunk group such as continuity test (COT). This table can be shared by multiple SS7 trunk groups.

Session Initiation Protocol

The Softswitch (SIP) Trunk Group Profile (`softsw-tg-profile`) table holds all the information specific to a Softswitch trunk, such as ID, protocol, indicators, and echo suppression. The `softsw-tg-profile` record can be shared by multiple softswitch trunk groups. An ID must be created in this table before entries can be added to the Softswitch Trunk Group table.

Generic Address Parameter Based Routing

Figure 5-5 shows an illustrated example of generic address parameter (GAP) based routing.

Figure 5-5 Generic Address Parameter Based Routing

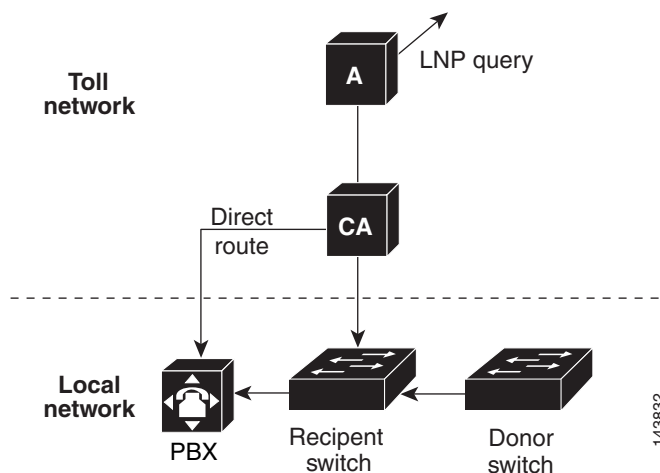

Tandem Provisioning

This section provides general information on tandem provisioning. For detailed information, refer to the [Cisco BTS 10200 Softswitch CLI Database](#). The following topics are discussed:

- [Automatic Number Identification](#)
- [Automatic Number Identification Screening](#)
- [Automatic Number Identification Screening Profile](#)
- [Cause Code Map](#)
- [Cause Code Map Profile](#)
- [H.323 Gateway](#)
- [H.323 Gateway to Gatekeeper](#)
- [H.323 Terminal](#)
- [H.323 Terminal Profile](#)
- [H.323 Trunk Group Profile](#)
- [II White Black List](#)
- [Service Provider](#)
- [Technical Prefix Group](#)
- [Technical Prefix Group Profile](#)
- [Trunk Group Feature Data](#)
- [Trunk Group Service Profile](#)

Automatic Number Identification

The ANI table is used for the ANI screening feature. The table keeps track of allowed/blocked status ANI. If the ANI status is blocked, the call is not allowed.

Automatic Number Identification Screening

The ANI Screening (ani-screening) table performs ANI screening on calls received over a trunk group. Normally, ANI screening is performed on calls received from a PBX (ISDN, H.323, and Session Initiation Protocol (SIP)). This table allows the performance of ANI-based routing in addition to ANI screening. When a record is found that matches the incoming ANI, the subscriber ID associated with the record is used for further digit analysis and routing.

Automatic Number Identification Screening Profile

The ANI Screening Profile (ani-screening-profile) table defines an ID to perform ANI screening. The ID is assigned to a trunk group when ANI screening is required or when ANI-based routing is required for calls originating over a trunk group.

Cause Code Map

The Cause Code Map (cause-code-map) table processes cause codes received from an outgoing interface. The cause-code-map table also processes cause codes when sending cause codes to a previous switch. It also specifies why a call was released.

When used for an outgoing interface, this table serves the following purposes:

- Determines what action the Cisco BTS 10200 takes for cause codes received over an outgoing interface
- Maps received cause codes to normalized cause codes

When used for an incoming interface, the table maps normalized cause codes to a cause code sent over the incoming interface. If no entry is found in the table, the Cisco BTS 10200 uses the cause code as is.

Cause Code Map Profile

The Cause Code Map Profile (cause-code-map-profile) table defines cause code map IDs, defines default mappings to a standard cause code (Q.850), and defines default actions to take. The cause code map IDs must be provisioned before the Cause Code table or the Trunk Group table are provisioned.

H.323 Gateway

The H.323 Gateway (h323-gw) table defines the capabilities of each H.323 protocol gateway. There can be four instances of an H.323 gateway running on the Call Agent at any one time.

H.323 Gateway to Gatekeeper

The H.323 Gateway to Gatekeeper (h323-gw2gk) table describes gatekeeper characteristics for each gateway in an H.323 network. Multiple gateways can have the same gatekeeper, or there can be a different gatekeeper for each gateway. However, a gateway can be registered to only one gatekeeper at a time. A gatekeeper identifies, controls, counts, and supervises gateway traffic, including, but not limited to, gateway registration, address resolution, bandwidth control, and admission control.

H.323 Terminal

The H.323 Terminal (h323-term) table holds information about H.323 terminals (such as H.323 audio/video phones) managed by the Call Agent and known in advance. This table is specific to H.323 subscribers.

H.323 Terminal Profile

The H.323 Terminal Profile (h323-term-profile) table defines the characteristics of group of H.323 terminals (or phones). An h323-term-profile ID must be created in this table before any H.323 subscriber entries can be added. This table contains almost all the same fields as from the H.323 Trunk Group Profile table, except for some that are specific to trunk side (such as Generic Transparency Descriptor (GTD)).

H.323 Trunk Group Profile

The H.323 Trunk Group Profile (h323-tg-profile) table defines the characteristics of each H.323 trunk. An h323-tg-profile ID must be created in this table before H.323 trunk group entries can be added.

II White Black List

The II White Black List (ii-wb-list) table allows or blocks calls from certain types of lines. The CoS Restrict ID specifies whether the list is to be used as a White List or Black List.

Service Provider

The Service Provider (service-provider) table is used when there are multiple service providers providing service through a single logical Call Agent.

Technical Prefix Group

The Technical Prefix Group (tech-prefix-grp) table provides a list of technical prefixes supported by a gateway. The same tech-prefix-list ID can be shared by multiple gateways. Each gateway must register the tech-prefixes that it supports to its gatekeeper.

Technical prefixes allow the inclusion of special characters in a called number. These special characters are commonly designated as a 1#, 2#, 3#, and so forth, and can be configured to prepend called number on the outgoing VoIP dial peer. The gatekeeper then checks its gateway technical prefix table for gateways registered with that particular tech prefix. Technology prefixes can also be used to identify a type, class, or pool of gateways.

The gatekeeper can be provisioned with technical prefixes in one of the following ways:

- Dynamically registered technical prefixes. The H.323 gateway registers one or more technical prefixes with the gatekeeper.
- Statically registered technical prefixes. The gatekeeper is provisioned with the technical prefixes and the gateways supporting them.
- Default technical prefixes also registered statically at the gatekeeper. If the gatekeeper does not receive a technical prefix in the admission request (ARQ), the gatekeeper uses the default technical prefixes.

One or more of technical prefixes can be provisioned in Cisco BTS 10200 and this group can be associated to an H.323 gateway. The Cisco BTS 10200 H.323 gateway process instance registers the technical prefixes from its technical prefix group with its primary gatekeeper. The technical prefix is encoded in the terminal Alias field of a registration request (RRQ) message as E.164 addresses. The gatekeeper routes calls to the Cisco BTS 10200 H.323 gateway based on the technical prefixes.

Technical Prefix Group Profile

The Technical Prefix Group Profile (tech-prefix-grp-profile) table identifies the IDs used for the Technical Prefix Group table. These IDs must be created in this table before entries can be added to the Technical Prefix Group table.

Trunk Group Feature Data

The Trunk Group Feature Data (trunk-grp-feature-data) table performs CoS screening for Tandem calls. If the received ANI is not found in the ANI table, and the casual-call flag is set to Y, the call is allowed. If the casual-call flag is set to N, the call is blocked. The cos-restrict-id performs the CoS screening.

Trunk Group Service Profile

The Trunk Group Service Profile (trunk-grp-service-profile) table links a trunk group to services.

Local Toll-Free Service Provisioning

The purpose of toll-free services is to have the called party, rather than the calling party, charged for the call. These calls are prefixed with the 1+8XX service access codes. The seven digits following the 8XX codes are used for routing the call. For an inbound/outbound 8XX call, the Cisco BTS 10200 checks the local toll-free database first. If the corresponding DN is not found in the local toll-free database, the system sends a query to the service control point (SCP) to request the corresponding DN.

All aspects of toll-free calling are transparent to the caller. A caller expects to dial 1-8XX-NXX-XXXX to reach the desired destination. The company that translates the number to a specific DN, and the company that routes the call, must appear transparent to callers. Most callers are not aware that their dialed 8XX number is changed into a specific DN. What matters to the callers is that they reach what they perceive to be the called number, and they are not billed for the call.

The following additional topics are discussed in this section:

- [Local Toll-Free Database](#)
- [Service Control Point-Based Toll-Free Services](#)
- [Automatic Number Identification White/Black List](#)
- [Customer Group](#)
- [DN2 Customer Group](#)
- [II Restrict List](#)

Local Toll-Free Database

The Cisco BTS 10200 provides the ability to translate inbound/outbound 8XX numbers at the Feature Server (FS) using a local 8XX database. The 8XX service supports the following features:

- Origin-dependent routing
- Time-of-day routing
- Percentage-based routing
- Information digit-based screening
- Black/white list screening

The Cisco BTS 10200 also supports optional dialed number identification service (DNIS). In an 8XX DNIS, when a call is terminated to a PBX (call center), 4 digits are outpulsed to the PBX to identify the originally dialed 8XX number. In case of custom DNIS, up to 22 digits can be outpulsed with additional information such as:

- Original 8XX number dialed
- Automatic number identification (ANI)
- Originating line information of the calling party

When a translated number (for an original 8XX call) is received, the Analyzed Info Dial Plan (DP) triggers the FS. The Cisco BTS 10200 looks up the DNIS and TG information for the call. The DNIS information is then outpulsed to the PBX. If an overflow condition is encountered, the call is routed to the overflow trunk. The overflow trunk can be a public switched telephone network (PSTN) trunk.

Service Control Point-Based Toll-Free Services

The Cisco BTS 10200 communicates with an SCP-based database called the toll-free database service, which contains information for routing the call. The database service provides information about the network service provider selected to complete the call, as well as information for translating the toll-free number to a specific 10-digit DN. The routing of the call can vary depending on the arrangements made between the toll-free subscriber and the network service provider. These arrangements can include selective routing based on the time of day, day of week, and location from which the call originates.

Automatic Number Identification White/Black List

The ANI White/Black List (ani-wb-list) table performs ANI screening on 800 calls. The Customer Group specifies if the list is to be used as a White List or a Black List. A White/Black List specifies whether calls are allowed to connect (white) or not allowed to connect (black).

Customer Group

The Customer Group (cust-grp) table defines the cust-grp-id and how ANI call forwarding and call restrictions are applied.

DN2 Customer Group

The DN2 Customer Group (dn2cust-grp) table provides translation of inbound/outbound 8XX (toll free) numbers to a local number and designated carrier.

II Restrict List

The II Restrict List (II-restrict-list) table restricts certain types of originating line services for a given group. The use of the list is determined by provisioning in the Customer Group table. This is a Black List (restrict) only. It cannot be a White List.

Carriers and Service Providers

This section provides general carrier/service provider information. The following subjects are discussed:

- [Carrier](#)
- [Route Guide](#)
- [Circuit Code](#)
- [Service Provider](#)

Carrier

The Carrier (carrier) table defines the characteristics and capabilities supported by interLATA carriers, intraLATA carriers, and international carriers, and it also provides routing information.

The following conditions apply when route-guide-id in the Carrier table is configured for a toll-free call:

- When a subscriber makes the call, the route-guide-id in the Carrier table is used to route the call if SCP returns a carrier ID.
- When SS7 makes a toll-free call, the route-guide-id in the Carrier table works only when traffic-type=tandem if SCP returns a carrier id. This is because that toll free call query normally happens at either a local switch made by a local user or at a tandem switch where the traffic type should be set to tandem.

Route Guide

The Route Guide (route-guide) table holds routing information based on policy-type. The Policy Prefix (policy-prefix) table provides information for call routing based on prefix (type of call). Typical call types include 1+ dialing, international calls, toll-free, and so on. This table is used mainly for carrier routing. The Policy Point of Presence (policy-pop) (POP) based policy routing routes a call to the nearest trunk group when there are multiple trunk groups.

There are several situations where a policy POP can be used. If a Call Agent serves several POPs, each POP can have its own announcement server. A POP-specific announcement server can be more efficient than a centralized announcement server. InterLATA carriers also have a point of presence in each POP. Route interLATA or international calls to the nearest carrier location using policy POP routing.

The Policy Origin Dependent Routing (policy-odr) table is used for origin-dependent routing. The numbering plan area (NPA) (or NPA-NXX) of the calling party number selects a route. If no match is found based on the calling party number, the route marked as default routes the call.

The Policy Region (policy-region) table performs region-based routing. The region is derived using the Region Profile table from the Route Guide table and the calling party number ANI. If ANI is not available or the Region Profile table is not provisioned, the region assigned to the trunk group is used for trunk origination. If a record cannot be found based on the region, the record with region=default (if provisioned) is used for routing.

For additional information on call types, refer to [Appendix A, “Call Types and Subtypes.”](#)

Circuit Code

The Circuit Code (circuit-code) table defines the circuit code value for the transit network selection (TNS) parameter. The circuit code value is defined based on the line, class of service, and call type. Special circuit code values are assigned to calls from coin or hotel or motel lines. If special circuit code values are not required, the default circuit code values are based on the call type sent.

Service Provider

The Service Provider (service-provider) table is used when there are multiple service providers providing service through a single logical Call Agent.

Carrier Based Routing

Carrier based routing enables the routing of Cisco BTS 10200 calls based on carrier. Carrier based routing provides multiple service provider support. Additionally, carrier based routing enables matching of the carrier ID and the trunk group to individual service providers. Individual dial plans can be configured for each service provider, or default routing can be enabled.

Call Processing Flow

This section describes the Cisco BTS 10200 call processing flow for calls terminating on a trunk and for calls terminating at a subscriber. The following topics are discussed:

- [Trunk Termination](#)
- [Subscriber Termination](#)

Trunk Termination

The trunk termination call flow is:

- Termination
- Subscriber
- Dial-plan
- Destination
- Route-guide
- Route
- Trunk group
- Trunk
- Termination

Subscriber Termination

The subscriber termination call flow is:

- Termination
- Subscriber
- Dial-plan
- Destination
- Office-code
- DN2Subscriber
- Subscriber
- Termination



CHAPTER 6

Command-Line Interface Routing

Revised: December 9, 2008, OL-15637-04

Introduction

This chapter provides a basic understanding of how the Cisco BTS 10200 Softswitch command-line interface (CLI) functions with of the routing types and call types. This chapter is divided into the following sections:

- [Routing Types](#)
- [Call Types](#)
- [Command-Line Interface Routing Examples](#)

For additional information on call types, refer to [Appendix A, “Call Types and Subtypes.”](#)



Note

When a customer is temporarily disconnected, all calls except 911 calls are routed to the customer support number.

Routing Types

This section provides the Cisco BTS 10200 CLI routing type information. The following topics are covered in this section:

- [Basic Subscriber Routing](#)
- [Basic Trunk Routing](#)
- [Carrier Based Routing](#)
- [Basic Dial Plan Routing](#)
- [Cluster Routing](#)

Basic Subscriber Routing

This section provides a detailed description of the Cisco BTS 10200 basic subscriber routing and provides CLI examples. For detailed information on the CLI, refer to the [Cisco BTS 10200 Softswitch CLI Database](#). Refer to [Figure 6-1](#) for visual representation of basic subscriber routing flow and review the following detailed basic subscriber routing flow.

-
- Step 1** Subscriber incoming received or placed.
Example:
[Subscriber Test1](#)
- Step 2** Get the subscriber table (sub-profile identification (ID)).
- Step 3** Get the subscriber-profile table (dial-plan-identification (DP-ID)).
Example:
[Subscriber and Sub-Profile](#)
- Step 4** Go to the dial-plan (based on DP-ID).
- Step 5** Go to destination table and get the call type and destination.
Example:
[Destination](#)
- Step 6** Determine the call type. If the call type is toll free, 900, or 500, proceed to Step 7. If the call type is casual, proceed to Step 8. If the call type is via a presubscribed interexchange carrier (PIC), proceed to Step 9.
Examples:
[Destination](#)
[Subscriber Test1](#)
- Step 7** If the call type is toll free, 900, or 500, the Cisco BTS 10200 will use the dial plan to select the call route and to route the call.
- Step 8** If the call type is casual, the Cisco BTS 10200 will use the carrier routing information to select the call route and to route the call.
- Step 9** If the call type is via a PIC, the Cisco BTS 10200 will use the PIC carrier routing information to select the call route and to route the call.
-

Figure 6-1 Basic Subscriber Routing

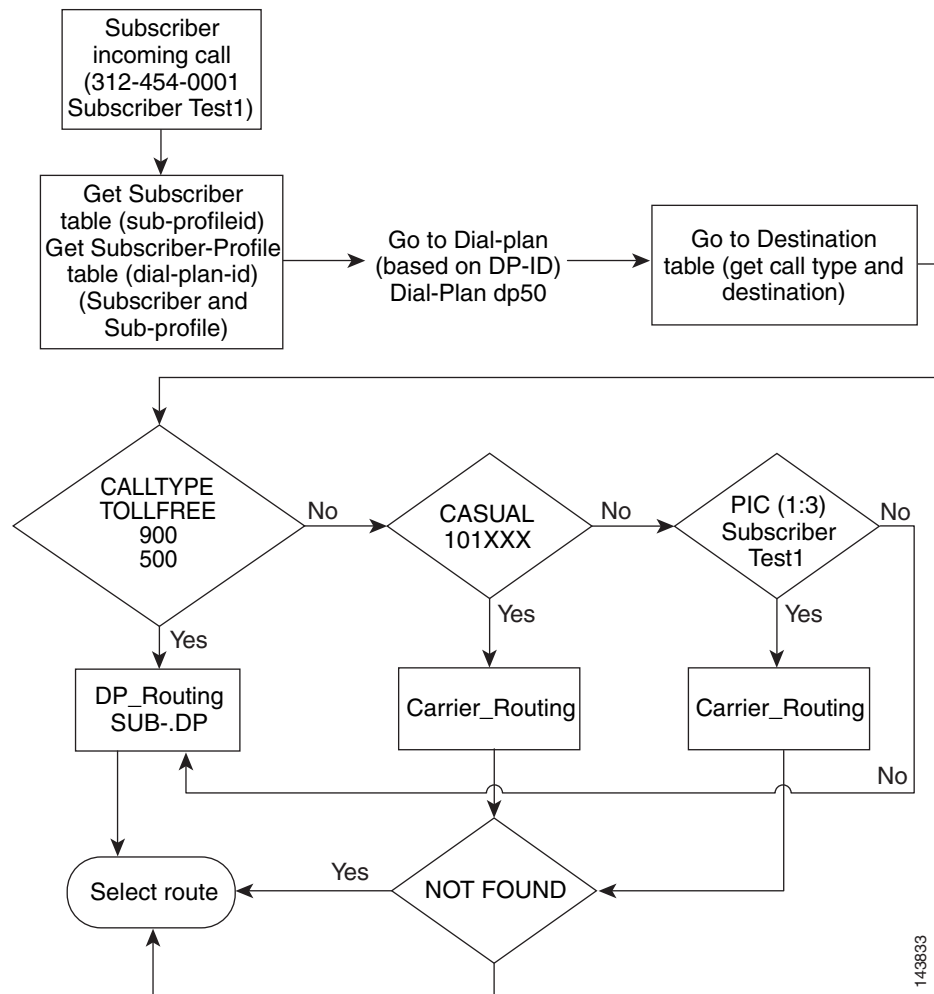

143833

Basic Trunk Routing

This section provides a detailed description of the Cisco BTS 10200 basic trunk routing and provides CLI examples. For detailed information on the CLI, refer to the [Cisco BTS 10200 Softswitch CLI Database](#). Refer to [Figure 6-2](#) for visual representation of basic trunk routing flow and review the following detailed basic trunk routing flow.

-
- Step 1** Trunk group (TG) call received or placed.
Example:
`Trunk-grp 6969`
- Step 2** Get the DP-ID from the TG.
Example:
`Trunk-grp 6969`
- Step 3** Go to the dial-plan and get the destination based on the digits and DP-ID.

Example:

[Dial-Plan](#)

Step 4 Go to the destination table and get the call type and the route.

Example:

[Destination](#)

Step 5 Determine the call type. If the call type is toll free, 900, or 500, proceed to Step 6. If the call type is local traffic, proceed to Step 7. If the call type is casual service provider (SP), proceed to Step 8. If the call type is transit network selection (TNS), proceed to Step 9. If the call type is TG carrier, proceed to Step 10. If the call type is TG SP, proceed to Step 11.

Example:

[Destination](#)

Step 6 If the call type is toll free, 900, or 500, the Cisco BTS 10200 will use the dial plan to select the call route and to route the call.

Examples:

[Dial-Plan](#)

[DN2sub](#)

Step 7 If the call type is local traffic, the Cisco BTS 10200 will use the dial plan to select the call route and to route the call.

Examples:

[Trunk-grp 6969](#)

[Dial-Plan](#)

[DN2sub](#)

Step 8 If the call type is casual SP, the Cisco BTS 10200 will use the SP routing to select the call route and to route the call. If the SP routing is not found, the Cisco BTS 10200 will use the dial plan to select the call route and to route the call.

Examples:

[Dial-Plan](#)

[DN2sub](#)

Step 9 If the call type is TNS, the Cisco BTS 10200 will use the carrier routing to select the call route and to route the call. If the carrier routing is not found, the Cisco BTS 10200 will use the dial plan to select the call route and to route the call.

Examples:

[Dial-Plan](#)

[DN2sub](#)

Step 10 If the call type is TG carrier, the Cisco BTS 10200 will use the carrier routing to select the call route and to route the call. If the carrier routing is not found, the Cisco BTS 10200 will use the dial plan to select the call route and to route the call.

Step 11 If the call type is TG SP, the Cisco BTS 10200 will use the SP routing to select the call route and to route the call. If the SP routing is not found, the Cisco BTS 10200 will use the dial plan to select the call route and to route the call.

Examples:

Dial-Plan
DN2sub

Figure 6-2 Basic Trunk Routing

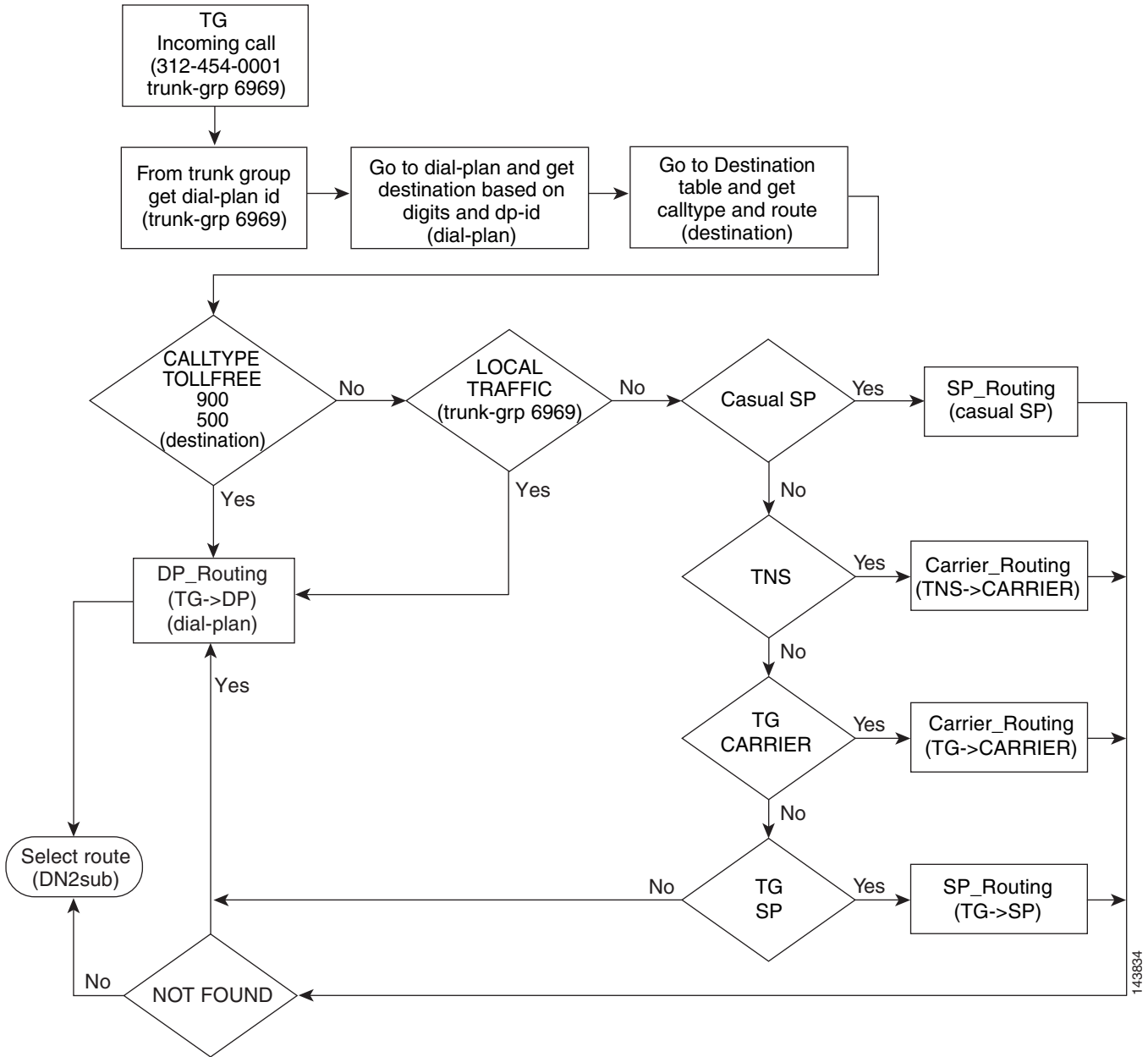

Carrier Based Routing

This section provides a detailed description of the Cisco BTS 10200 carrier based routing and provides CLI examples. For detailed information on the CLI, refer to the [Cisco BTS 10200 Softswitch CLI Database](#). Refer to [Figure 6-3](#) for visual representation of carrier based routing flow and review the following detailed carrier based routing flow.

Additionally, LNP-QUERY has been added to the call flow. LNP-QUERY specifies whether to perform a local number portability (LNP) query on the call type. LNP_QUERY applies only if the ALL-CALL-QUERY flag in the LNP-PROFILE table is set to Y and the ACQ-LNP-QUERY token in the Destination table is set to ACQ-BASED-ON-CALL-TYPE. For complete LNP-QUERY details, refer to the [Cisco BTS 10200 Softswitch CLI Database](#) and the “[NOA Routing \(ITU Local Number Portability\)](#)” section on page 2-12.

-
- Step 1** Carrier based routing call is received.
- Step 2** Determine if the carrier is being screened. If the carrier is being screened, proceed to Step 3. If the carrier is not being screened, proceed to Step 4.
- Example:
[Carrier 9999 Use Dial-Plan “N”](#)
- Step 3** If the carrier is being screened, the Cisco BTS 10200 will determine if the carrier call processing is being remotely blocked (RTM_CP_BLOCK). If the carrier call processing is being remotely blocked, the call cannot be completed and will be dropped.
- Step 4** If the carrier is not being screened, the Cisco BTS 10200 will determine if the carrier is a recognized service provider. If the carrier is a recognized service provider, proceed to Step 5. If the carrier is not a recognized service provider, proceed to Step 6.
- Example:
[Carrier – Service-Provider](#)
- Step 5** If the carrier is a recognized service provider, the Cisco BTS 10200 will use the service provider routing to select the call route and to route the call.
- Example:
[Service Provider](#)
- Step 6** If the carrier is not a recognized service provider, the Cisco BTS 10200 will determine if a carrier dial plan is configured. If a carrier dial plan is configured, proceed to Step 7. If a carrier dial plan, is not configured proceed to Step 8.
- Example:
[Carrier Use Dial-Plan “Y”](#)
[Carrier 9999 Use Dial-Plan “N”](#)
- Step 7** If a carrier dial plan is configured, the Cisco BTS 10200 will use the carrier dial plan to select the call route and to route the call.
- Step 8** If a carrier dial plan is not configured, the Cisco BTS 10200 will determine if a carrier remote call processing to local exchange carrier operations support system is available (RTM_CP_CARRIER_2_LECOSS). If the RTM_CP_CARRIER_2_LECOSS is available, proceed to Step 9. If the RTM_CP_CARRIER_2_LECOSS is not available, proceed to Step 10.

**Note**

Step 8 is skipped for toll traffic. If the traffic is toll traffic, proceed to Step 10.

Step 9 If the RTM_CP_CARRIER_2_LECOSS is available and if the traffic is not toll traffic, the Cisco BTS 10200 will use the RTM_CP_CARRIER_2_LECOSS to select the call route and to route the call.

Example:

Carrier All=N

Step 10 If the RTM_CP_CARRIER_2_LECOSS is not available, the Cisco BTS 10200 will use the carrier guide index to select the call route and to route the call.

Example:

Carrier All=Y

Figure 6-3 Carrier Based Routing

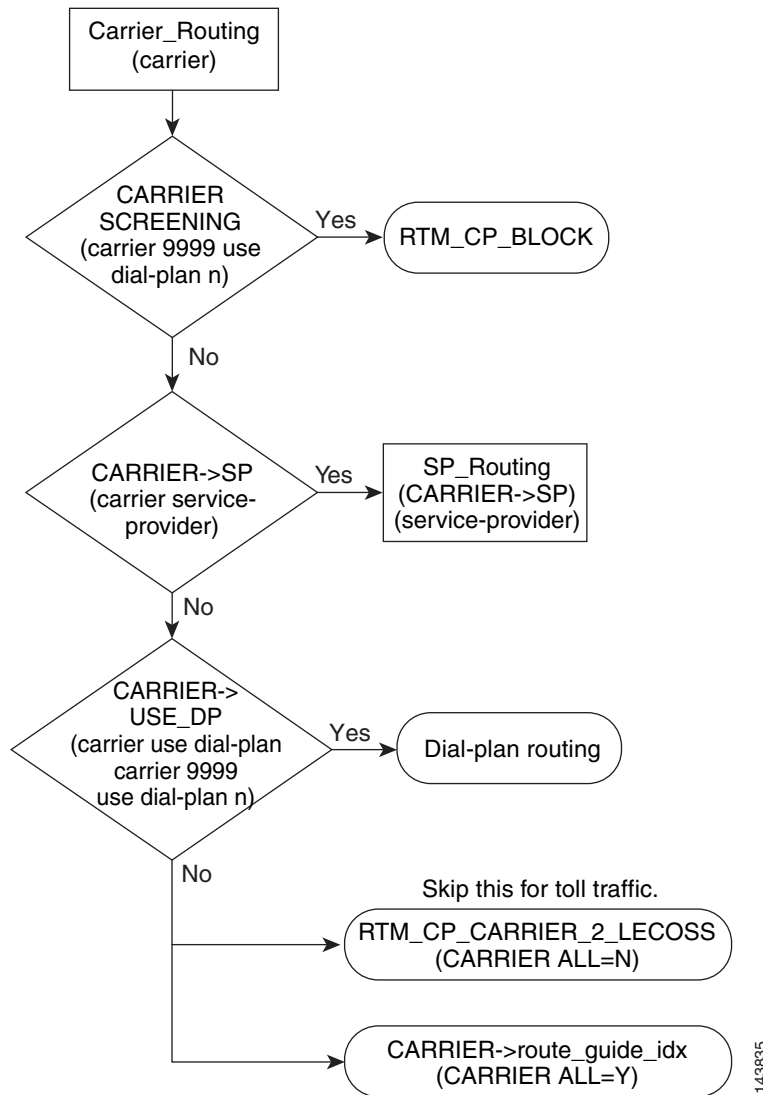

Basic Dial Plan Routing

This section provides a detailed description of the Cisco BTS 10200 basic dial plan routing and provides CLI examples. For detailed information on the CLI, refer to the [Cisco BTS 10200 Softswitch CLI Database](#). Refer to [Figure 6-4](#) for visual representation of basic dial plan routing flow and review the following detailed basic dial plan routing flow.

-
- Step 1** Basic dial plan routing call received.
- Step 2** Determine if the nature of address (NOA) for the received call is an international call. If the call is an international call, the Cisco BTS 10200 uses the international dial plan to select the call route and to route the call. If the call is not an international call, proceed to Step 3.
- Example:
[Dial-Plan Ca-Config](#)
- Step 3** Determine if the call destination is found. If the call destination is not found, the Cisco BTS 10200 returns a destination not found response (not found) and drops the call. If the call destination is found, proceed to Step 4.
- Step 4** Determine if a call destination subscriber is found. If a call destination subscriber is found, the Cisco BTS 10200 returns a subscriber (SUB) response and uses the subscriber information to select the call route and to route the call. If a call destination subscriber is not found, proceed to Step 5.
- Example:
[Destination SUB](#)
- Step 5** Determine if a call destination route is found. If a call destination route is found, the Cisco BTS 10200 returns a destination (DEST) response and uses the route guide index to select the call route and to route the call. If a call destination route is not found, proceed to Step 6.
- Example:
[Destination ROUTE](#)
- Step 6** Determine if a call destination route identification (RID) is found. If a call destination RID is found, the Cisco BTS 10200 returns a DEST response and uses the route index to select the call route and to route the call. If a call destination RID is not found, proceed to Step 7.
- Example:
[Destination RID](#)
- Step 7** Determine if a destination carrier is found. If a destination carrier is found, proceed to the Step 8. If a destination carrier is not found, the Cisco BTS 10200 returns an error and drops the call.
- Example:
[Destination Carrier](#)
- Step 8** Determine the call type. If the call type is toll free, 900, or 500, the Cisco BTS 10200 selects the call route and routes the call using the destination carrier routing. If the call type is not toll free, 900, or 500, the Cisco BTS 10200 returns an error and drops the call.
-

Figure 6-4 Basic Dial Plan Routing

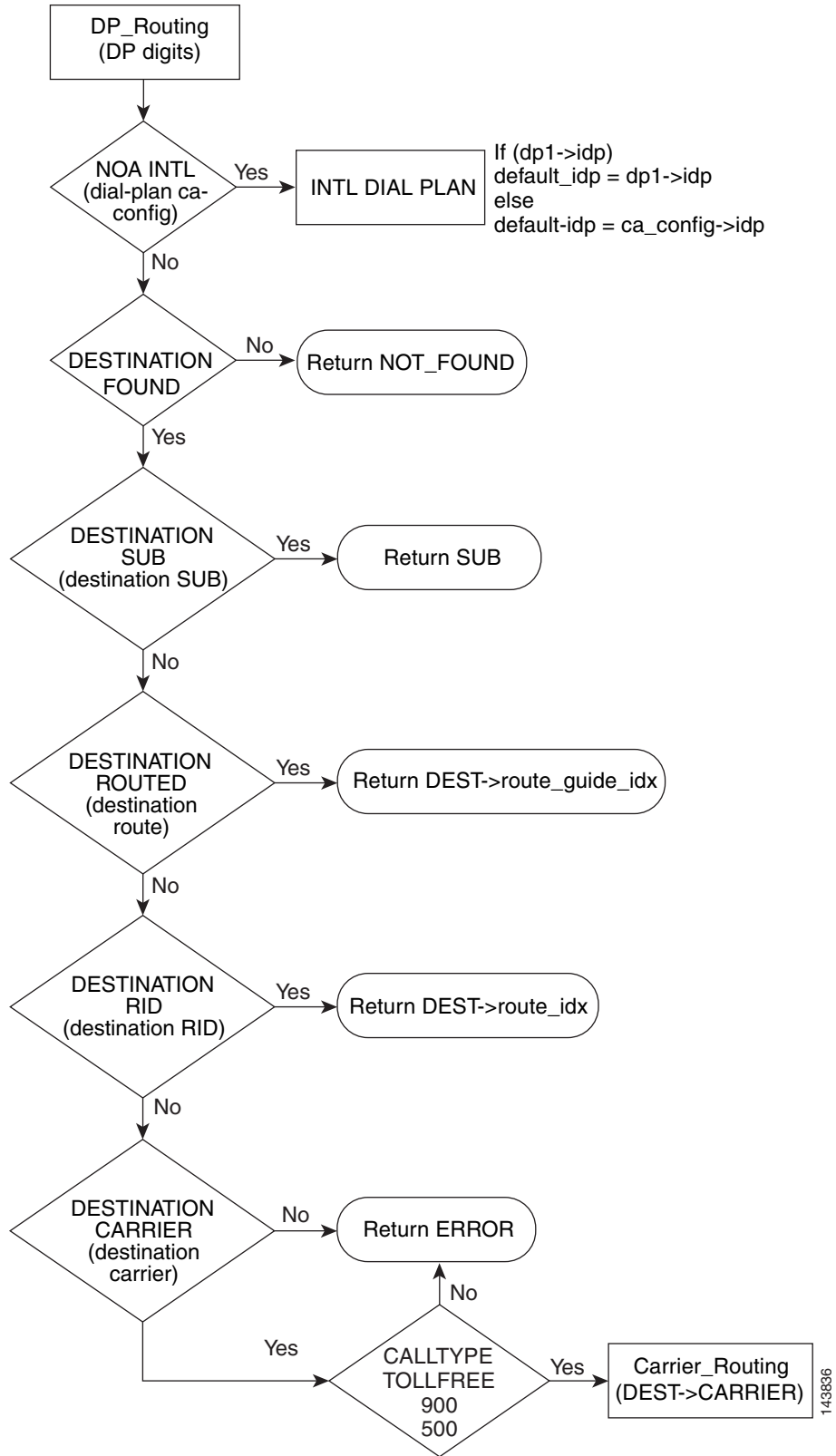

Cluster Routing

This section provides an overview of CLI commands that you need to implement the Cluster Network/Routing supported by the Cisco BTS 10200 in Release 5.0.

The CLI commands provided in the following sections are not in any particular sequence, and could be executed in any order as long as dependencies of the table in question are already in place. The main intention of this document is to summarize the CLI commands that would be needed to implement cluster networking.

Creating a Cluster Network with Three CMS/MGCs

Figure 6-5 illustrates creation of a cluster network with three CMS/MGCs.

Figure 6-5 *Creating a Cluster Network with Three CMS/MGC*

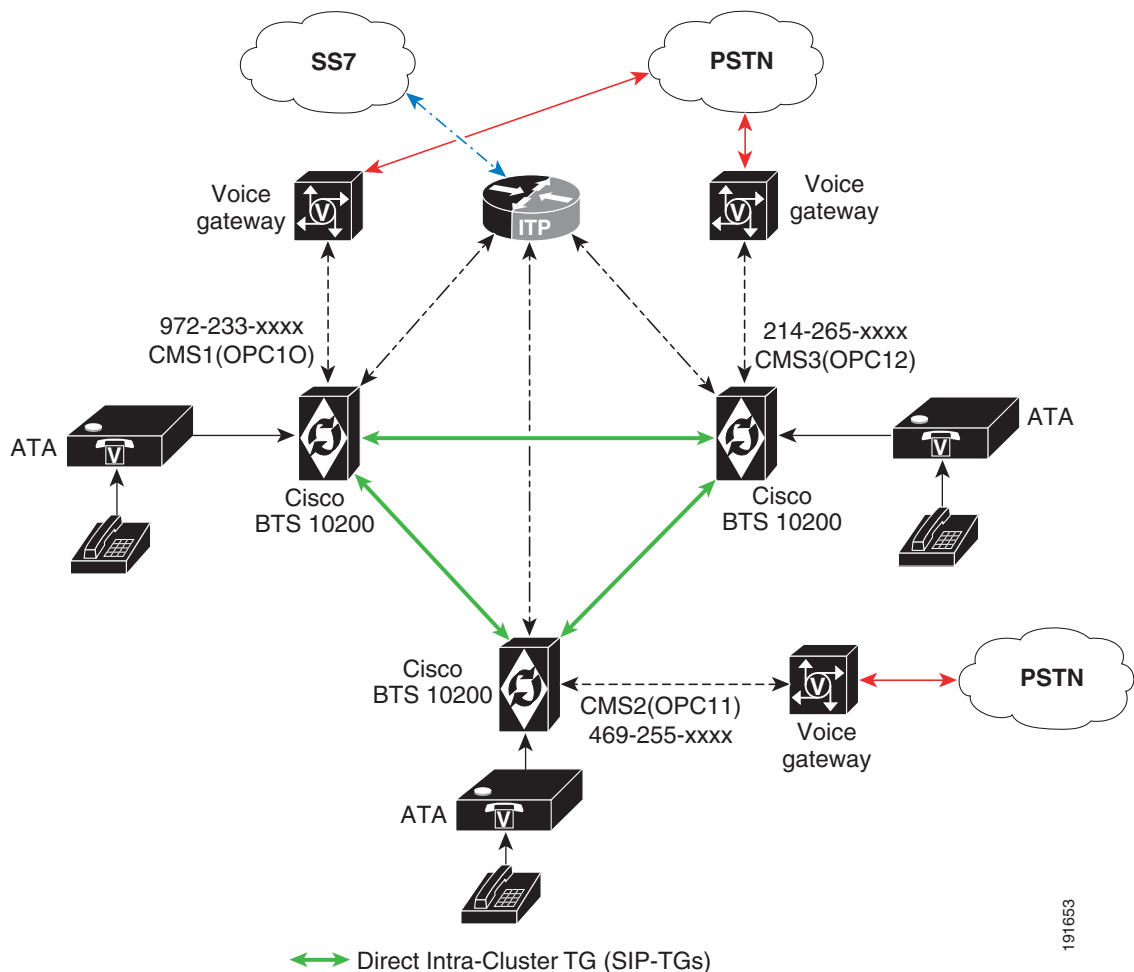

1. Clustering requires switches to have their individual point codes and here we are assuming the existing three switches to already have point codes of OPC10, OPC11 and OPC12.
2. The Cisco BTS 10200 switches have an Intra-cluster TG (SIP TG) connected between each of them as shown in the diagram. (Basically each CMS/MGC in the network needs to have direct connectivity with the other switches.)

```

add trunk-grp id=sip_1_2 ;tg-type=sip;dial-plan-id=cluster-dial-plan;
tsap-addr=CMS2;
add trunk-grp id=sip_1_3 ;tg-type=sip;dial-plan-id=cluster-dial-plan;
tsap-addr=CMS3;

add trunk-grp id=sip_2_3 ;tg-type=sip;dial-plan-id=cluster-dial-plan;
tsap-addr=CMS3;
add trunk-grp id=sip_2_1 ;tg-type=sip;dial-plan-id=cluster-dial-plan;
tsap-addr=CMS1;

add trunk-grp id=sip_3_1 ;tg-type=sip;dial-plan-id=cluster-dial-plan;
tsap-addr=CMS1;
add trunk-grp id=sip_3_2 ;tg-type=sip;dial-plan-id=cluster-dial-plan;
tsap-addr=CMS2;

```

Make sure the POI flag in the trunk-grp table for each of the trunk-grp's added above is set to INTRA-CLUSTER.

3. Decide on a CLRN (assuming it to be 972-999-9999 in this case) and provision the CLRN into each of the CMS/MGCs. The CLRN also needs to be registered in the LNP database.

On CMS1/CMS2/CMS3:

```

add ndc digit-string=972;
add exchange-code ndc=972;ec=999;office-code-index=1;
add office-code ndc=972;ec=999;call-agent-id=CA146;dn-group=xxxx;
add dn2subscriber office_code_index=1;dn=9999;status=CLRN;

```

4. Each CMS/MGC needs to have a separate NPA-NXX.

This basically means each CMS needs to handle a separate NPA-NXX, so as shown in the diagram we have CMS1 handling 972-233, CMS2 handling 469-255 and CMS3 handling 214-265.

5. Provision the cluster dial plan (NPA-NXX routing) in each of the CMS/MGCs to reach each other.

On CMS1:

```

add cluster-dial-plan-profile id=cdpp;

add route id=CMS3;tgn1_id=sip_1_3;
add route id=CMS2;tgn1_id=sip_1_2;

add destination dest-id=CMS3;route-type=ROUTE-ID;route-id=CMS3;call-type=LOCAL;
add destination dest-id=CMS2;route-type=ROUTE-ID;route-id=CMS2;call-type=LOCAL;

add dial-plan id=cdpp;digit-string=214-265;dest-id=CMS3;
add dial-plan id=cdpp;digit-string=469-255;dest-id=CMS2;

add ca-config;cluster-dial-plan id=cdpp;

```

For CMS2:

```

add cluster-dial-plan-profile id=cdpp;

add route id=CMS1;tgn1_id=sip_2_1;
add route id=CMS3;tgn1_id=sip_2_3;

add destination dest-id=CMS1;route-type=ROUTE-ID;route-id=CMS1;call-type=LOCAL;
add destination dest-id=CMS3;route-type=ROUTE-ID;route-id=CMS3;call-type=LOCAL;

add dial-plan id=cdpp;digit-string=972-233;dest-id=CMS1;
add dial-plan id=cdpp;digit-string=214-265;dest-id=CMS3;

add ca-config;cluster-dial-plan id=cdpp;

```

For CMS3:

```
add cluster-dial-plan-profile id=cdpp;

add route id=CMS1;tgn1_id=sip_3_1;
add route id=CMS2;tgn1_id=sip_3_2;

add destination dest-id=CMS1;route-type=ROUTE-ID;route-id=CMS1;call-type=local;
add destination dest-id=CMS2;route-type=ROUTE-ID;route-id=CMS2;call-type=local;

add dial-plan id=cdpp;digit-string=972-233;dest-id=CMS1;
add dial-plan id=cdpp;digit-string=469-255;dest-id=CMS2;

add ca-config;cluster-dial-plan id=cdpp;
```

Ported-In Sub from PSTN into CMS1

Imagine a subscriber from PSTN (972-384-1234) ported into one of the CMSs in the cluster—say CMS1. If a subscriber on any of the CMSs makes a call to that ported number this is the provisioning needed.

On CMS1:

```
add ported-office-code digit-string=972-384;
add dn2subscriber office-code-index=1;dn=1234;;status=assigned;lnp_trigger=y;
```

On CMS2:

```
add ported-office-code digit-string=972-384;
add dial-plan id=cdpp;digit-string=972-384;dest-id=CMS1;
```

On CMS3:

```
add ported-office-code digit-string=972-384;
add dial-plan id=cdpp;digit-string=972-384;dest-id=CMS1;
```

If the call comes in from the PSTN for this ported number, it would have already come in with a CLRN number. It depends on which CMS in the cluster receives the call first. Assume that CMS3 received the call (since it's a CLRN), CMS3 would look up the GAP and route the call to CMS1 as specified in the cluster dial plan entries.

Adding One More CMS/MGC to a Cluster Network

Figure 6-6 illustrates adding one more CMS/MGC to a cluster network.

Figure 6-6 Adding One More CMS/MGC to the Cluster Network

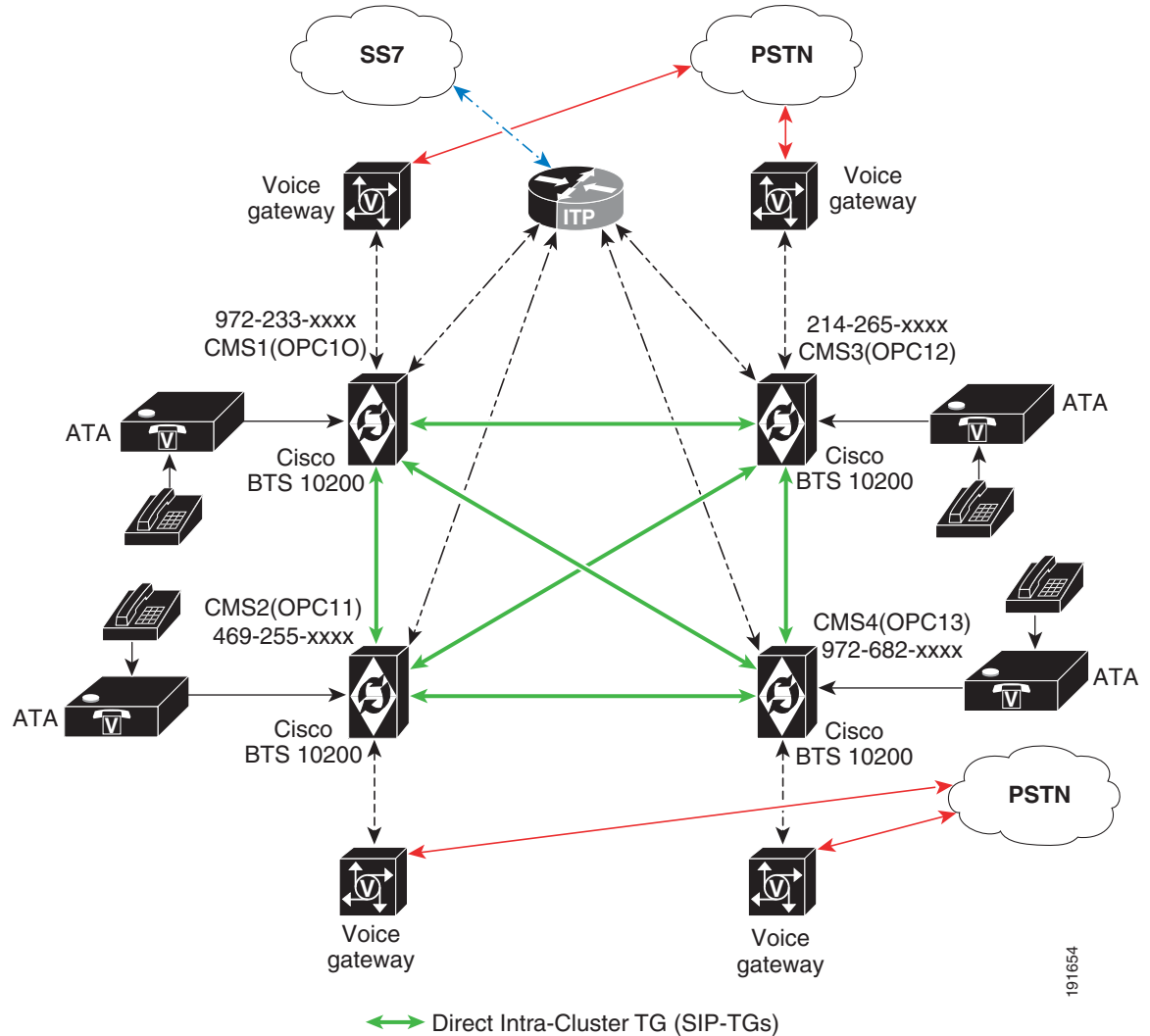

191654

1. Assign separate point codes for the new CMS/MGC switch.

```
add opc id=13; point-code=4-4-4; description=CMS 04 ; (On CMS4)
add dpc id=PSTN;point-code=x-x-x; description= PSTN conn from CMS4;
```

2. Have an Intra-cluster TG (SIP TG) connected between each of them as shown in the diagram.

On CMS4:

```
add trunk-grp id=sip_4_1 ;tg-type=sip;dial-plan-id=cluster-dial-plan; tsap-addr=CMS1;
add trunk-grp id=sip_4_2 ;tg-type=sip;dial-plan-id=cluster-dial-plan; tsap-addr=CMS2;
add trunk-grp id=sip_4_3 ;tg-type=sip;dial-plan-id=cluster-dial-plan; tsap-addr=CMS3;
```

On CMS1:

```
add trunk-grp id=sip_1_4 ;tg-type=sip;dial-plan-id=cluster-dial-plan; tsap-addr=CMS4;
```

On CMS2:

```
add trunk-grp id=sip_2_4 ;tg-type=sip;dial-plan-id=cluster-dial-plan; tsap-addr=CMS4;
```

On CMS3:

```
add trunk-grp id=sip_3_4 ;tg-type=sip;dial-plan-id=cluster-dial-plan; tsap-addr=CMS4;
```

3. Add an entry in dn2sub table for the CLRN of the cluster which is 972-999-9999.

```
add ndc digit-string=972;
add exchange-code ndc=972;ec=999;office-code-index=1;
add office-code ndc=972;ec=999;call-agent-id=CA146;dn-group=xxxx;
add dn2subscriber office_code_index=1;dn=9999;status=CLRN;
```

4. Each switch needs to have its own NPA-NXX, so let's assume CMS4 handles 972-682-xxxx.
5. Provision the cluster dial plan (NPA-NXX routing) in each of the CMS/MGC switches to reach the others.

On CMS4:

```
add cluster-dial-plan-profile id=cdpp;

add route id=CMS1;tgn1_id=sip_4_1;
add route id=CMS2;tgn1_id=sip_4_2;
add route id=CMS3;tgn1_id=sip_4_3;

add destination dest-id=CMS1;route-type=ROUTE-ID;route-id=CMS1;call-type=local;
add destination dest-id=CMS2;route-type=ROUTE-ID;route-id=CMS2;call-type=local;
add destination dest-id=CMS3;route-type=ROUTE-ID;route-id=CMS3;call-type=local;

add dial-plan id=cdpp;digit-string=972-233;dest-id=CMS1;
add dial-plan id=cdpp;digit-string=469-255;dest-id=CMS2;
add dial-plan id=cdpp;digit-string=214-265;dest-id=CMS3;

add ca-config;cluster-dial-plan id=cdpp;
```

On CMS1:

```
add route id=CMS4;tgn1_id=sip_1_4;

add destination dest-id=CMS4;route-type=ROUTE-ID;route-id=CMS4;call-type=local;

add dial-plan id=cdpp;digit-string=972-682;dest-id=CMS4;
```

On CMS2:

```
add route id=CMS4;tgn1_id=sip_2_4;

add destination dest-id=CMS4;route-type=ROUTE-ID;route-id=CMS4;call-type=local;

add dial-plan id=cdpp;digit-string=972-682;dest-id=CMS4;
```

On CMS3:

```
add route id=CMS4;tgn1_id=sip_3_4;

add destination dest-id=CMS4;route-type=ROUTE-ID;route-id=CMS4;call-type=local;

add dial-plan id=cdpp;digit-string=972-682;dest-id=CMS4;
```

Call Types

This section provides detailed information on CLI usage for the Cisco BTS 10200 call types. CLI information on the following call types is provided:

- [1+ InterLATA Call](#)
- [1+ IntraLATA Call](#)
- [0+ InterLATA Call](#)
- [0+ IntraLATA Call](#)
- [Ported-In Call Processing](#)

For additional information on call types, refer to [Appendix A, “Call Types and Subtypes.”](#)

1+ InterLATA Call

This section describes the Cisco BTS 10200 routing and call flow for 1+ interLATA calls and provides some CLI examples. For information on the CLI, refer to the [Cisco BTS 10200 Softswitch CLI Database](#). Refer to [Figure 6-7](#) for visual representation of the 1+ interLATA call routing flow and review the following detailed 1+ interLATA call routing flow.

-
- Step 1** A 1+ interLATA call is received.
- Examples:
- [Subscriber Test1](#)
- [Dp50 Digit-String=202](#)
- Step 2** Determine if a 101XXXX number has been dialed. If a 101XXXX number has been dialed, the Cisco BTS 10200 selects the call route and routes the call based on the carrier access code (CAC). If a 101XXXX number has not been dialed, proceed to Step 3.
- Step 3** Check the subscriber table to determine if a PIC is defined. If a PIC is defined, the Cisco BTS 10200 selects the call route and routes the call based on the PIC information. If a PIC is not defined, proceed to Step 4.
- Example:
- [Subscriber and Sub-Profile](#)
- Step 4** Check the point of presence (POP) table. If a block-eawopic is configured, the Cisco BTS 10200 blocks the call. If a block-eawopic is not configured, proceed to Step 5.
- Examples:
- [POP 50 No Block](#)
- [POP 50 Block](#)
- Step 5** Determine if a local exchange carrier operations support system (LECOSS) is defined in the POP table. If a LECOSS is defined in the POP table, the Cisco BTS 10200 selects to route the call through use of the LECOSS. If a LECOSS is not defined in the POP table, the Cisco BTS 10200 blocks the call.
- Examples:
- [POP LEC-OSS](#)

POP 50 No Block

Figure 6-7 1+ InterLATA Call

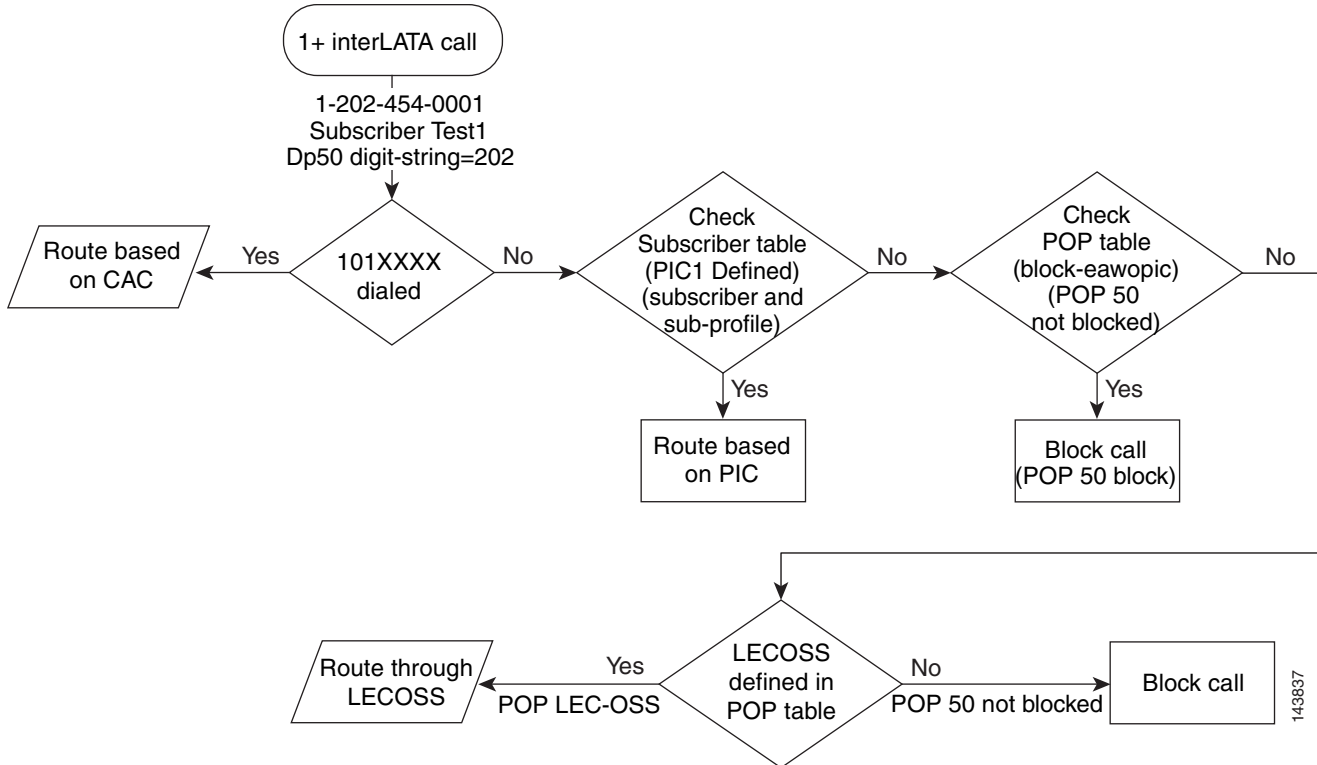

1+ IntraLATA Call

This section provides a detailed description of the Cisco BTS 10200 routing and call flow for 1+ intraLATA calls and provides some CLI examples. For information on the CLI, refer to the [Cisco BTS 10200 Softswitch CLI Database](#). Refer to [Figure 6-8](#) for visual representation of the 1+ intraLATA call routing flow and review the following detailed 1+ intraLATA call routing flow.

-
- Step 1** An 1+ intraLATA call is received.
- Examples:
- [Subscriber Test1](#)
- [Sub DP Dest IntraLATA](#)
- Step 2** Determine if 101XXXX number has been dialed. If a 101XXXX number has been dialed, proceed to Step 3. If a 101XXXX number has not been dialed, proceed to Step 4.
- Step 3** Check the Carrier table for a CAC. If a CAC is available, the Cisco BTS 10200 selects the call route and route the call based on the CAC. If a CAC is not available, proceed to Step 3a.
- Example:
- [Carrier Intra=Y](#)

Determine if a LECOSS is defined in the POP table. If a LECOSS is defined in the POP table, the Cisco BTS 10200 selects the call route and routes the call through use of the LECOSS. If a LECOSS is not defined in the POP table, the Cisco BTS 10200 blocks the call.

- Step 4** Check the POP table for a configured IP transfer point (ITP). If an ITP is configured, proceed to Step 4a. If an ITP is not configured, the Cisco BTS 10200 routes the call through use of the dial plan routing.

Example:

[POP ITP=Y](#)

- a. Check the subscriber table for a specified PIC. If a PIC is specified, proceed to Step 4b. If a PIC is not specified, the Cisco BTS 10200 routes the call to the announcement server and checks the POP table for a specified PIC. If a PIC is not specified, the Cisco BTS 10200 blocks the call or if a dial plan is available, the Cisco BTS 10200 selects the call route and routes the call according to the dial plan routing information.

Examples:

[Subscriber Test1](#)

[Sub DP Dest IntraLATA](#)

- b. Check the intra-carrier table for a specified PIC. If a PIC is specified in the intra-carrier table, the Cisco BTS 10200 selects the call route and routes the call based on the PIC information. If a PIC is not specified in the intra-carrier table, proceed to Step 4c.

Example:

[Carrier Intra=Y](#)

- c. Determine if a LECOSS is defined in the POP table. If a LECOSS is defined in the POP table, the Cisco BTS 10200 selects the call route and routes the call through the LECOSS. If a LECOSS is not defined in the POP table, the Cisco BTS 10200 blocks the call.

Example:

[POP LEC-OSS](#)

Carrier Op-Serv=Y

- Step 4** Check the POP table for a defined LECOSS. If a LECOSS is defined in the POP table, the Cisco BTS 10200 routes the call through the LECOSS. If a LECOSS is not defined in the POP table, the Cisco BTS 10200 blocks the call.

Example:

POP LEC-OSS

- Step 5** Check the subscriber table for a defined PIC. If a PIC is defined in the subscriber table, proceed to Step 6. If a PIC is not defined in the subscriber table, proceed to Step 7.

Example:

Subscriber Test1

- Step 6** Check the subscriber profile for an ea-use-pic entry. If the subscriber profile contains an ea-use-pic entry, the Cisco BTS 10200 selects the call route and routes the call based on the PIC information. If the subscriber profile does not contain an ea-use-pic entry, return to Step 4.

Examples:

Ea-Use=Y**POP Ea-use=N**

- Step 7** Check the POP table for a block-eawopic entry. If the POP table contains a block-eawopic entry, the Cisco BTS 10200 blocks the call. If the POP table does not contain a block-eawopic entry, return to Step 4.

Examples:

POP Block-ea=N**POP Block-ea=Y**

Figure 6-9 0+ InterLATA Call

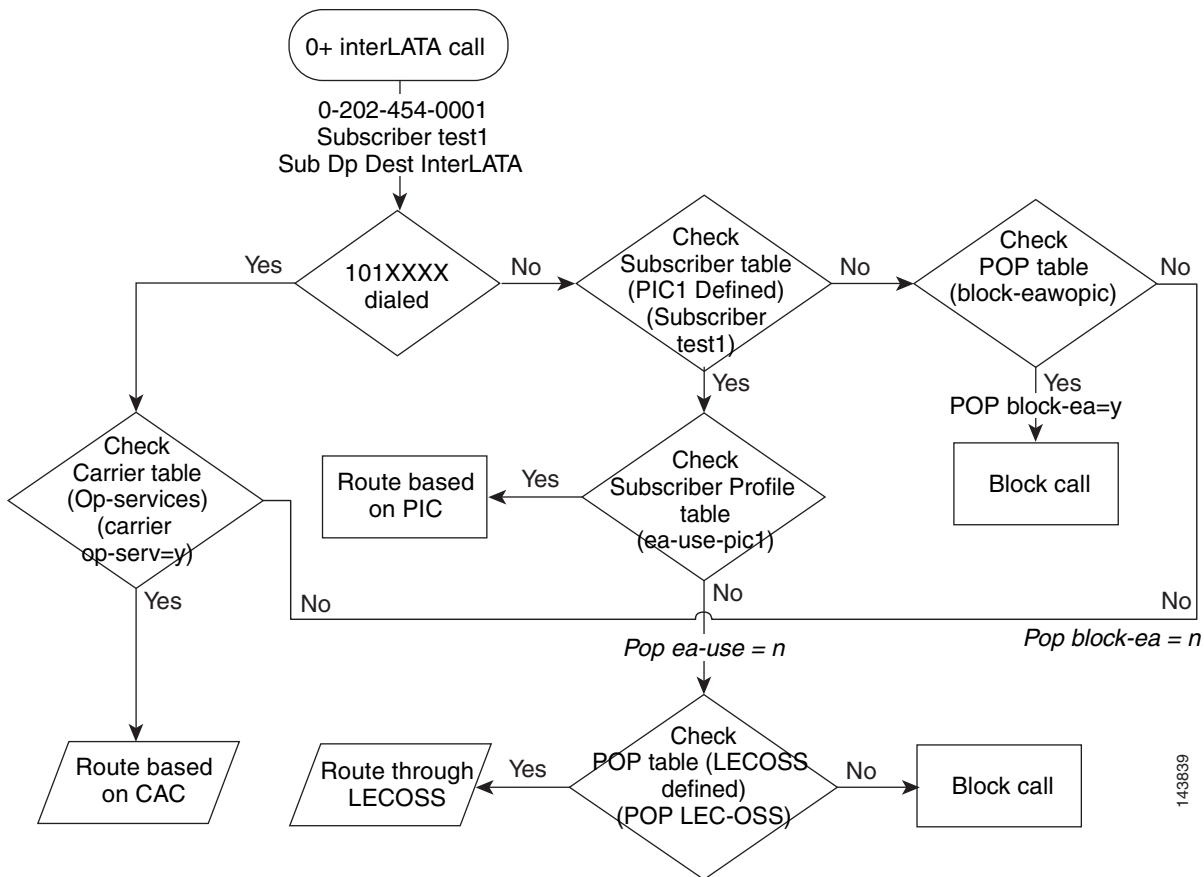

0+ IntraLATA Call

This section describes the Cisco BTS 10200 routing and call flow for 0+ intraLATA calls and provides CLI examples. For information about the CLI, refer to the [Cisco BTS 10200 Softswitch CLI Database](#). Refer to [Figure 6-10](#) for visual representation of the 0+ intraLATA call routing flow and review the following detailed 0+ intraLATA call routing flow.

-
- Step 1** A 0+ intraLATA call is received.
- Examples:
- [Subscriber Test1](#)
- [Sub DP Dest IntraLATA](#)
- Step 2** Determine if a 101XXXX number was dialed. If a 101XXXX number was dialed, proceed to Step 3. If a 101XXXX number was not dialed, proceed to Step 5.
- Step 3** Check the Carrier table for a CAC. If a CAC is available, the Cisco BTS 10200 selects the call route and routes the call based on the CAC. If a CAC is not available, proceed to Step 4.
- Example:
- [Carrier Op-Serv=Y](#)

Step 4 Check the POP table for a defined LECOSS. If a LECOSS is defined in the POP table, the Cisco BTS 10200 routes the call through the LECOSS. If a LECOSS is not defined in the POP table, the Cisco BTS 10200 blocks the call.

Example:

[POP LEC-OSS](#)

Step 5 Check the POP table for a configured ITP. If an ITP is configured, proceed to Step 6. If an ITP is not configured return to Step 4.

Example:

[POP ITP=Y](#)

Step 6 Check the subscriber table for a specified PIC. If a PIC is specified, proceed to Step 7. If a PIC is not specified, the Cisco BTS 10200 routes the call to the announcement server. Additionally, if a PIC is not specified in the subscriber table, the Cisco BTS 10200 checks the POP table for a specified PIC. If a PIC is specified in the POP table, the Cisco BTS 10200 blocks the call. If a PIC is not specified in the POP table, return to Step 4.

Examples:

[Subscriber Test1](#)

[POP LEC-OSS](#)

Step 7 Check the intra-carrier table for the specified PIC. If the specified PIC is included in the intra-carrier table, the Cisco BTS 10200 selects the call route and routes the call based on the PIC information. If the specified PIC is not included in the intra-carrier table, return to Step 4.

Example:

[Carrier Intra=Y](#)

Figure 6-10 0+ IntraLATA Call

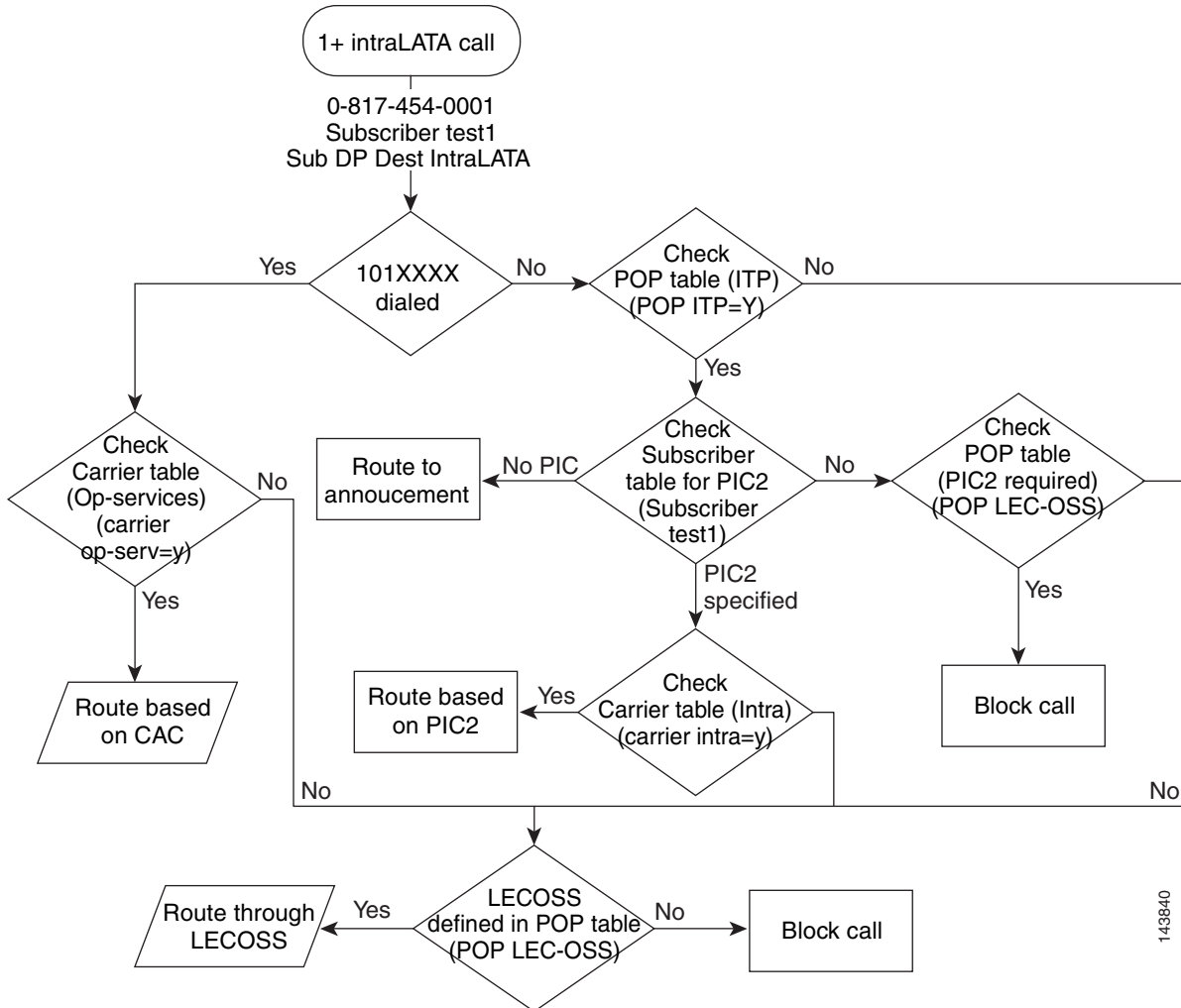

143840

Ported-In Call Processing

This section describes the Cisco BTS 10200 routing and call flow for ported-in call processing calls and provides CLI examples. For information on the CLI, refer to the [Cisco BTS 10200 Softswitch CLI Database](#). Refer to [Figure 6-11](#) for visual representation of the ported-in call processing call routing flow and review the following detailed ported-in call processing call routing flow.

-
- Step 1** A ported-in call is received.
- Step 2** The office code is not assigned to the Cisco BTS 10200.
- Step 3** Determine if the office code is in the ported-in office code table. If the office code is in the ported-in office code table, proceed to Step 4. If the office code is not in the ported-in office code table, perform normal call processing.

Example:

[Ported-Office-Code in CA](#)

Step 4 Determine if the in-call agent flag is set. If the in-call agent flag is set, proceed to Step 5. If the in-call agent flag is not set, the Cisco BTS 10200 performs a local number portability (LNP) query.

Examples:

[Ported-Office-Code in CA=N](#)

[Ported-Office-Code in CA](#)

Step 5 Determine if the subscriber is included in the dn2subscriber table. If the subscriber is included in the dn2subscriber table, proceed to Step 6. If the subscriber is not included in the dn2subscriber table, proceed to Step 7.

Examples:

[In DN2Sub](#)

[Not in DN2Sub](#)

Step 6 Determine if the LNP trigger flag is set. If the LNP trigger flag is set, the Cisco BTS 10200 performs a LNP query and ports out the call. If the LNP trigger flag is not set, the Cisco BTS 10200 checks the status field to determine if an LNP trigger has been assigned and ports out the call or terminates the call to the subscriber.

Examples:

[LNP Trigger=Y](#)

[In DN2Sub](#)

Step 7 Check the destination table for the subscriber information. Based on the destination table information, the Cisco BTS 10200 routes the call or issues a subscriber terminator, releases the call, and plays the released call announcement. As part of routing the call, the Cisco BTS 10200 performs an LNP query and, if necessary, ports out the call.

Examples:

[LNP Local Sub](#)

[LNP Route](#)

Figure 6-11 Ported-In Call Processing

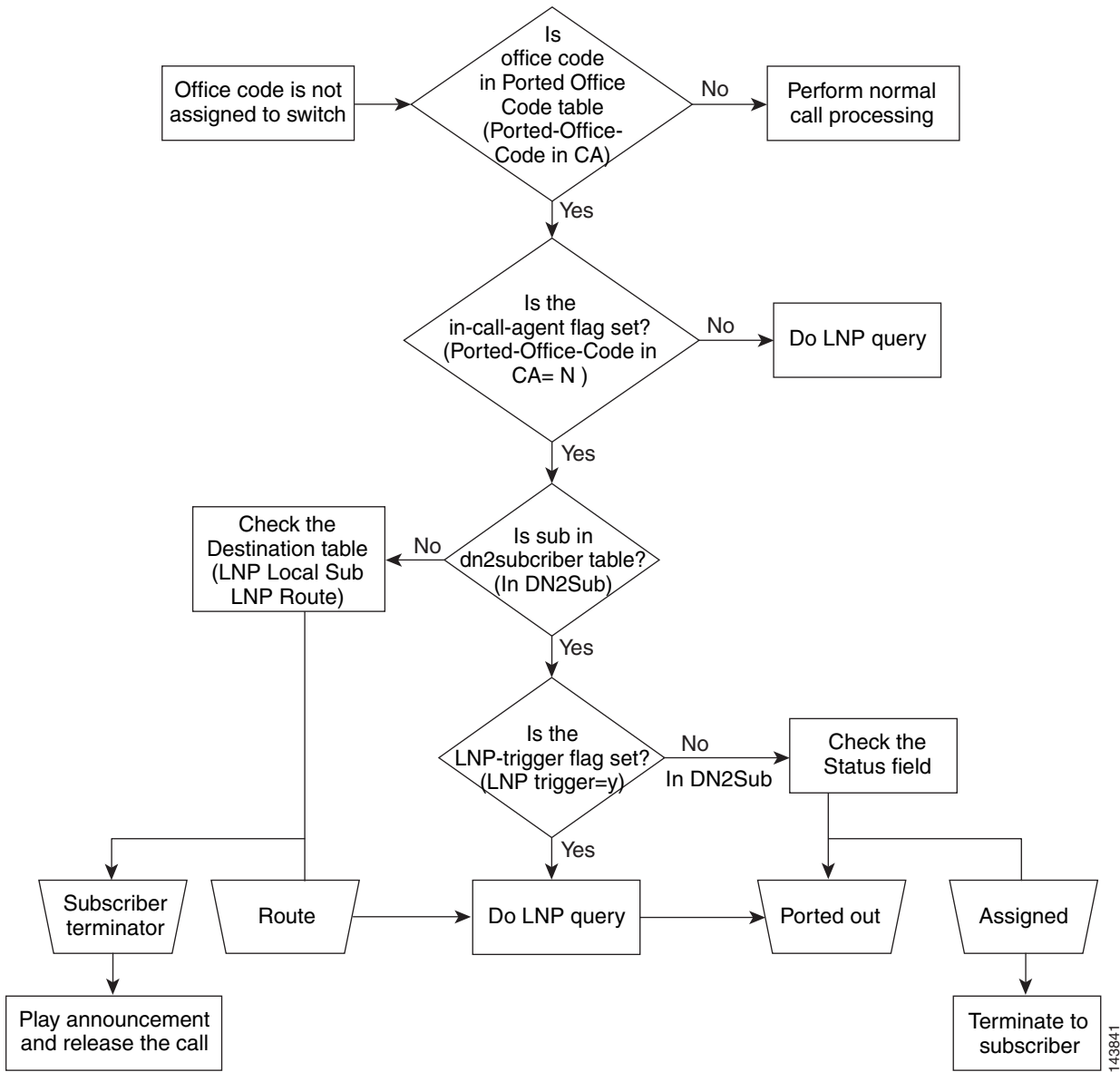

143841

Command-Line Interface Routing Examples

This section provides the following CLI routing examples:

- Carrier – Service-Provider
- Carrier 9999 Use Dial-Plan “N”
- Carrier All=N
- Carrier All=Y
- Carrier Intra=Y
- Carrier Op-Serv=Y
- Carrier Use Dial-Plan “Y”
- Destination
- Destination Carrier
- Destination InterLATA
- Destination RID
- Destination ROUTE
- Destination SUB
- Dial-Plan
- Dial-Plan Ca-Config
- Dial-Plan “dp50”
- DN2sub
- Dp50 Digit-String=202
- Ea-Use=Y
- In DN2Sub
- LNP Local Sub
- LNP Route
- LNP Trigger=Y
- Not in DN2Sub
- POP 50 Block
- POP 50 No Block
- POP Block-ea=N
- POP Block-ea=Y
- POP Ea-use=N
- POP ITP=Y
- POP LEC-OSS
- Ported-Office-Code in CA
- Ported-Office-Code in CA=N
- Service Provider
- Sub DP Dest InterLATA

- [Sub DP Dest IntraLATA](#)
- [Subscriber Test1](#)
- [Subscriber Test2](#)
- [Subscriber and Sub-Profile](#)
- [Trunk-grp 6969](#)

Carrier – Service-Provider

The following Carrier – Service-Provider CLI example is used in the [Carrier Based Routing](#) example.

```
CLI>show carrier id=7777
Reply : Success: Entry 1 of 1 returned.

ID=7777
STATUS=INS
INTER=Y
INTRA=N
INTL=N
CASUAL=Y
CUT_THRU=Y
OP_SERVICES=Y
SEND_CN=N
SEND_CSP=N
USE_DIAL_PLAN=N
ROUTE_GUIDE_ID=test
SP_ID=test
NETWORK_TYPE=NOTUSED
NATIONAL_NETWORK_PLAN=NOTUSED
```

Carrier 9999 Use Dial-Plan “N”

The following Carrier 9999 Use Dial-Plan “N” CLI example is used in the [Carrier Based Routing](#) example.

```
CLI>show carrier id=9999
Reply : Success: Entry 1 of 1 returned.

ID=9999
STATUS=INS
INTER=Y
INTRA=N
INTL=N
CASUAL=Y
CUT_THRU=Y
OP_SERVICES=Y
SEND_CN=N
SEND_CSP=N
USE_DIAL_PLAN=N
NETWORK_TYPE=NOTUSED
NATIONAL_NETWORK_PLAN=NOTUSED
```

Carrier All=N

The following Carrier All=N CLI example is used in the [Carrier Based Routing](#) example.

```
CLI>show carrier id=7777
Reply : Success: Entry 1 of 1 returned.

ID=7777
STATUS=INS
INTER=N
INTRA=N
INTL=N
CASUAL=N
CUT_THRU=N
OP_SERVICES=N
SEND_CN=N
SEND_CSP=N
USE_DIAL_PLAN=N
ROUTE_GUIDE_ID=test
NETWORK_TYPE=NOTUSED
NATIONAL_NETWORK_PLAN=NOTUSED
```

Carrier All=Y

The following Carrier All=Y CLI example is used in the [Carrier Based Routing](#) example.

```
CLI>show carrier id=7777
Reply : Success: Entry 1 of 1 returned.

ID=7777
STATUS=INS
INTER=Y
INTRA=Y
INTL=Y
CASUAL=Y
CUT_THRU=Y
OP_SERVICES=Y
SEND_CN=N
SEND_CSP=N
USE_DIAL_PLAN=N
ROUTE_GUIDE_ID=TEST
NETWORK_TYPE=NOTUSED
NATIONAL_NETWORK_PLAN=NOTUSED
```

Carrier Intra=Y

The following Carrier Intra=Y CLI example is used in the [1+ IntraLATA Call](#) and [0+ IntraLATA Call](#) routing examples.

```
CLI>show carrier id=9999
Reply : Success: Entry 1 of 1 returned.

ID=9999
STATUS=INS
INTER=Y
INTRA=Y
INTL=N
CASUAL=Y
CUT_THRU=Y
OP_SERVICES=Y
SEND_CN=N
SEND_CSP=N
USE_DIAL_PLAN=Y
NETWORK_TYPE=NOTUSED
NATIONAL_NETWORK_PLAN=NOTUSED
```

Carrier Op-Serv=Y

The following Carrier Op-Serv=Y CLI example is used in the [0+ InterLATA Call](#) and [0+ IntraLATA Call](#) routing examples.

```
CLI>show carrier id=7777
Reply : Success: Entry 1 of 1 returned.

ID=7777
STATUS=INS
INTER=Y
INTRA=N
INTL=N
CASUAL=Y
CUT_THRU=Y
OP_SERVICES=Y
SEND_CN=N
SEND_CSP=N
USE_DIAL_PLAN=N
ROUTE_GUIDE_ID=TEST
SP_ID=test
NETWORK_TYPE=NOTUSED
NATIONAL_NETWORK_PLAN=NOTUSED
```

Carrier Use Dial-Plan “Y”

The following Carrier Use Dial-Plan “Y” CLI example is used in the [Carrier Based Routing](#) example.

```
CLI>show carrier id=8888
Reply : Success: Entry 1 of 1 returned.

ID=8888
STATUS=INS
INTER=Y
INTRA=N
INTL=N
CASUAL=Y
CUT_THRU=Y
OP_SERVICES=Y
SEND_CN=N
SEND_CSP=N
USE_DIAL_PLAN=Y
DESCRIPTION=TEST
NETWORK_TYPE=NOTUSED
NATIONAL_NETWORK_PLAN=NOTUSED
```

Destination

The following Destination CLI example is used in the [Basic Subscriber Routing](#) example and the [Basic Trunk Routing](#) example.

```
CLI>show destination

DEST_ID=local-sub
CALL_TYPE=LOCAL
ROUTE_TYPE=SUB
ZERO_PLUS=N
INTRA_STATE=Y
GAP_ROUTING=N
```

Destination Carrier

The following Destination Carrier CLI example is used in the [Basic Dial Plan Routing](#) example.

```
CLI>show destination dest-id=800;
Reply : Success: Entry 1 of 1 returned.

DEST_ID=800
CALL_TYPE=TOLL_FREE
ROUTE_TYPE=CARRIER
CARRIER_ID=7777
ZERO_PLUS=N
INTRA_STATE=Y
GAP_ROUTING=N
```

Destination InterLATA

The following Destination interLATA CLI example is used in the [1+ InterLATA Call](#) routing example.

```
CLI>show destination dest-id=interLATA
Reply : Success: Entry 1 of 1 returned.

DEST_ID=interLATA
CALL_TYPE=interLATA
ROUTE_TYPE=ROUTE
ROUTE_GUIDE_ID=TEST
ZERO_PLUS=N
INTRA_STATE=Y
GAP_ROUTING=N
```

Destination RID

The following Destination RID CLI example is used in the [Basic Dial Plan Routing](#) example.

```
CLI>show destination dest-id=65019
Reply : Success: Entry 1 of 1 returned.

DEST_ID=65019
CALL_TYPE=LOCAL
ROUTE_TYPE=RID
ZERO_PLUS=N
INTRA_STATE=Y
ROUTE_ID=65019
GAP_ROUTING=N
```

Destination ROUTE

The following Destination ROUTE CLI example is used in the [Basic Dial Plan Routing](#) example.

```
CLI>show destination dest-id=65019
Reply : Success: Entry 1 of 1 returned.

DEST_ID=65019
CALL_TYPE=LOCAL
ROUTE_TYPE=ROUTE
ROUTE_GUIDE_ID=local6561200
ZERO_PLUS=N
INTRA_STATE=Y
GAP_ROUTING=N
```

Destination SUB

The following Destination SUB CLI example is used in the [Basic Dial Plan Routing](#) example.

```
CLI>show destination dest-id=65019
Reply : Success: Entry 1 of 1 returned.

DEST_ID=65019
CALL_TYPE=LOCAL
ROUTE_TYPE=SUB
ZERO_PLUS=N
INTRA_STATE=Y
GAP_ROUTING=N
```

Dial-Plan

The following Dial-Plan CLI example is used in the [Basic Trunk Routing](#) example.

```
CLI>show dial-plan id=dp50;digit-string=312-454;
Reply : Success: Entry 1 of 1 returned.
```

```
ID=dp50
DIGIT_STRING=312454
REQD_DIGITS=10
DEST_ID=local-sub
SPLIT_NPA=NONE
MIN_DIGITS=10
MAX_DIGITS=10
NOA=NATIONAL
```

Dial-Plan Ca-Config

The following Dial-Plan Ca-Config CLI example is used in the [Basic Dial Plan Routing](#) example.

Dial-Plan Ca-Config Example:

```
CLI>show dial-plan-profile id=dp51
Reply : Success: Entry 1 of 1 returned.
```

```
ID=dp51
INTL_DIAL_PLAN_ID=dp50
NANP_DIAL_PLAN=Y
```

```
CLI>show dial-plan-profile id=dp50
Reply : Success: Entry 1 of 1 returned.
```

```
ID=dp50
DESCRIPTION=dialing plan 1
NANP_DIAL_PLAN=Y
```

```
CLI>show ca-config TYPE=DEFAULT-INTL-DIAL-PLAN-ID;
Reply : Success: Entry 1 of 1 returned.
```

```
TYPE=DEFAULT-INTL-DIAL-PLAN-ID
DATATYPE=STRING
VALUE=DEFAULT
```

Dial-Plan “dp50”

The following Dial-Plan “dp50” CLI example is used in the [Basic Subscriber Routing](#) routing example.

```
CLI>show dial-plan id=dp50
Reply: Success: Entries 1-3 of 3 returned.
```

```
ID=dp50
DIGIT_STRING=212454
REQD_DIGITS=10
DEST_ID=local-sub
SPLIT_NPA=NONE
MIN_DIGITS=10
MAX_DIGITS=10
NOA=NATIONAL
```

```
ID=dp50
DIGIT_STRING=312454
REQD_DIGITS=10
DEST_ID=local-sub
SPLIT_NPA=NONE
MIN_DIGITS=10
MAX_DIGITS=10
NOA=NATIONAL
```

```
ID=dp50
DIGIT_STRING=412454
REQD_DIGITS=10
DEST_ID=local-sub
SPLIT_NPA=NONE
MIN_DIGITS=10
MAX_DIGITS=10
NOA=NATIONAL
```

DN2sub

The following DN2sub CLI example is used in the [Basic Subscriber Routing](#) and [Ported-In Call Processing](#) examples.

```
CLI>show ndc digit-string=312
Reply : Success: Entry 1 of 1 returned.
```

```
DIGIT_STRING=312
```

```
CLI>show exchange-code ndc=312
Reply : Success: Entry 1 of 1 returned.
```

```
NDC=312
EC=454
OFFICE_CODE_INDEX=1188
MIN_DN_LENGTH=10
MAX_DN_LENGTH=10
```

```
CLI>show office-code ndc=312; ec=454
Reply : Success: Entry 1 of 1 returned.
```

```
DIGIT_STRING=312454
OFFICE_CODE_INDEX=1188
DID=N
CALL_AGENT_ID=CA552
DIALABLE=Y
```

```

NDC=312
EC=454
DN_GROUP=xxxx

CLI>show dn2subscriber office-code-index=1188
Reply : Success: Entry 1 of 1 returned.

OFFICE_CODE_INDEX=1188
DN=0001
STATUS=ASSIGNED
RING_TYPE=1
LNP_TRIGGER=N
NP_RESERVED=N
SUB_ID=test2

```

Dp50 Digit-String=202

The following Dp50 Digit-String=202 CLI example is used in the [1+ InterLATA Call](#) routing example.

```

CLI>show dial-plan id=dp50; digit-string=202;
Reply : Success: Entry 1 of 1 returned.

ID=dp50
DIGIT_STRING=202
REQD_DIGITS=10
DEST_ID=interLATA
SPLIT_NPA=NONE
MIN_DIGITS=10
MAX_DIGITS=10
NOA=NATIONAL

CLI>show destination dest-id=interLATA
Reply : Success: Entry 1 of 1 returned.

DEST_ID=interLATA
CALL_TYPE=interLATA
ROUTE_TYPE=ROUTE
ROUTE_GUIDE_ID=test
ZERO_PLUS=N
INTRA_STATE=Y
GAP_ROUTING=N

```

Ea-Use=Y

The following Ea-Use=Y CLI example is used in the [0+ InterLATA Call](#) routing example.

```

CLI>show sub-profile id=sp50
Reply : Success: Entry 1 of 1 returned.

ID=sp50
DIAL_PLAN_ID=dp50
LOCAL_PFX1_OPT=NR
TOLL_PFX1_OPT=RQ
POP_ID=50
OLI=0
EA_USE_PIC1=Y

```

In DN2Sub

The following In DN2Sub CLI example is used in the [Ported-In Call Processing](#) routing example.

```
CLI>show office-code digit-string=214-387
Reply : Success: Entry 1 of 1 returned.

DIGIT_STRING=214387
OFFICE_CODE_INDEX=657
DID=N
CALL_AGENT_ID=CA552
DIALABLE=Y
NDC=214
EC=387
DN_GROUP=xxxx

CLI>show dn2subscriber OFFICE_CODE_INDEX=657;dn=1000
Reply : Success: Entry 1 of 1 returned.

OFFICE_CODE_INDEX=657
DN=1000
STATUS=ASSIGNED
RING_TYPE=1
LNP_TRIGGER=N
NP_RESERVED=N
SUB_ID=test1
```

LNP Local Sub

The following LNP Local Sub CLI example is used in the [Ported-In Call Processing](#) routing example.

```
CLI>show dial-plan id=dp50;digit-string=214-387
Reply : Success: Entry 1 of 1 returned.

ID=dp50
DIGIT_STRING=214387
DEST_ID=local-sub
SPLIT_NPA=NONE
MIN_DIGITS=10
MAX_DIGITS=10
NOA=NATIONAL

CLI>show destination dest-id=local-sub
Reply : Success: Entry 1 of 1 returned.

DEST_ID=local-sub
CALL_TYPE=LOCAL
ROUTE_TYPE=SUB
ZERO_PLUS=N
INTRA_STATE=Y
GAP_ROUTING=N
```

LNP Route

The following LNP Route CLI example is used in the [Ported-In Call Processing](#) routing example.

```
CLI>show dial-plan id=dp50;digit-string=214-387
Reply : Success: Entry 1 of 1 returned.
```

```
ID=dp50
DIGIT_STRING=214387
DEST_ID=out
SPLIT_NPA=NONE
MIN_DIGITS=10
MAX_DIGITS=10
NOA=NATIONAL
```

```
CLI>show destination dest-id=local-sub
Reply : Success: Entry 1 of 1 returned.
```

```
DEST_ID=out
CALL_TYPE=LOCAL
ROUTE_TYPE=ROUTE
ROUTE_GUIDE_ID=TEST
ZERO_PLUS=N
INTRA_STATE=Y
GAP_ROUTING=N
```

LNP Trigger=Y

The following LNP Trigger=Y CLI example is used in the [Ported-In Call Processing](#) routing example.

```
CLI>show dn2subscriber OFFICE_CODE_INDEX=657;dn=1000
Reply : Success: Entry 1 of 1 returned.
```

```
OFFICE_CODE_INDEX=657
DN=1000
STATUS=ASSIGNED
RING_TYPE=1
LNP_TRIGGER=Y
NP_RESERVED=N
SUB_ID=test1
```

Not in DN2Sub

The following Not in DN2Sub CLI example is used in the [Ported-In Call Processing](#) routing examples.

```
CLI>show office-code digit-string=214-387
Reply : Success: Entry 1 of 1 returned.
```

```
DIGIT_STRING=214387
OFFICE_CODE_INDEX=657
DID=N
CALL_AGENT_ID=CA552
DIALABLE=Y
NDC=214
EC=387
DN_GROUP=xxxx
```

```
CLI>show dn2subscriber OFFICE_CODE_INDEX=657;dn=1000
Reply : Success: Database is void of entries.
```

POP 50 Block

The following POP 50 Block CLI example is used in the [1+ InterLATA Call](#) routing example.

```
CLI>show pop id=50
Reply : Success: Entry 1 of 1 returned.

ID=50
STATE=tx
COUNTRY=usa
TIMEZONE=CST
LOCAL_7D_DIALING=Y
ITP=N
ZERO_MINUS=LEC
BLOCK_EAWOPIC=Y
CNAM_OPTION=NONE
PIC2_REQD=N
TREAT_IMS_ANONYMOUS=N
```

POP 50 No Block

The following POP 50 No Block CLI example is used in the [1+ InterLATA Call](#) routing example.

```
CLI>show pop id=50
Reply : Success: Entry 1 of 1 returned.

ID=50
STATE=tx
COUNTRY=usa
TIMEZONE=CST
LOCAL_7D_DIALING=Y
ITP=N
ZERO_MINUS=LEC
BLOCK_EAWOPIC=N
CNAM_OPTION=NONE
PIC2_REQD=N
TREAT_IMS_ANONYMOUS=N
```

POP Block-ea=N

The following POP Block-ea=N CLI example is used in the [0+ InterLATA Call](#) routing example.

```
CLI>show pop id=50
Reply : Success: Entry 1 of 1 returned.

ID=50
STATE=tx
COUNTRY=usa
TIMEZONE=CST
LOCAL_7D_DIALING=Y
ITP=Y
ZERO_MINUS=LEC
BLOCK_EAWOPIC=N
CNAM_OPTION=NONE
PIC2_REQD=N
LECOSS_ROUTE_GUIDE_ID=TEST
TREAT_IMS_ANONYMOUS=N
```

POP Block-ea=Y

The following POP Block-ea=Y CLI example is used in the [0+ InterLATA Call](#) routing example.

```
CLI>show pop id=50
Reply : Success: Entry 1 of 1 returned.

ID=50
STATE=tx
COUNTRY=usa
TIMEZONE=CST
LOCAL_7D_DIALING=Y
ITP=Y
ZERO_MINUS=LEC
BLOCK_EAWOPIC=Y
CNAM_OPTION=NONE
PIC2_REQD=N
LECOSS_ROUTE_GUIDE_ID=TEST
TREAT_IMS_ANONYMOUS=N
```

POP Ea-use=N

The following POP Ea-use=N CLI example is used in the [0+ InterLATA Call](#) routing example.

```
CLI>show sub-profile id=sp50
Reply : Success: Entry 1 of 1 returned.

ID=sp50
DIAL_PLAN_ID=dp50
LOCAL_PFX1_OPT=NR
TOLL_PFX1_OPT=RQ
POP_ID=50
OLI=0
EA_USE_PIC1=N
```

POP ITP=Y

The following POP ITP=Y CLI example is used in the [1+ IntraLATA Call](#) and [0+ IntraLATA Call](#) routing examples.

```
CLI>show pop id=50
Reply : Success: Entry 1 of 1 returned.

ID=50
STATE=tx
COUNTRY=usa
TIMEZONE=CST
LOCAL_7D_DIALING=Y
ITP=Y
ZERO_MINUS=LEC
BLOCK_EAWOPIC=Y
CNAM_OPTION=NONE
PIC2_REQD=N
LECOSS_ROUTE_GUIDE_ID=TEST
TREAT_IMS_ANONYMOUS=N
```

POP LEC-OSS

The following POP LEC-OSS CLI example is used in the [1+ InterLATA Call](#), [1+ IntraLATA Call](#), [0+ InterLATA Call](#), and [0+ IntraLATA Call](#) routing examples.

```
CLI>show pop id=50
Reply : Success: Entry 1 of 1 returned.

ID=50
STATE=tx
COUNTRY=usa
TIMEZONE=CST
LOCAL_7D_DIALING=Y
ITP=N
ZERO_MINUS=LEC
BLOCK_EAWOPIC=Y
CNAM_OPTION=NONE
PIC2_REQD=N
LECOSS_ROUTE_GUIDE_ID=TEST
TREAT_IMS_ANONYMOUS=N
```

Ported-Office-Code in CA

The following Ported-Office-Code in CA CLI example is used in the [Ported-In Call Processing](#) routing example.

```
CLI>show ported-office-code digit-string=214-387
Reply : Success: Entry 1 of 1 returned.

DIGIT_STRING=214387
IN_CALL_AGENT=Y
```

Ported-Office-Code in CA=N

The following Ported-Office-Code in CA=N CLI example is used in the [Ported-In Call Processing](#) routing example.

```
CLI>show ported-office-code digit-string=214-387
Reply : Success: Entry 1 of 1 returned.

DIGIT_STRING=214387
IN_CALL_AGENT=N
```

Service Provider

The following Service Provider CLI example is used in the [Carrier Based Routing](#) example.

```
CLI>show service-provider id=test
Reply : Success: Entry 1 of 1 returned.

ID=test
SP_BASED_ROUTING=N
USE_DIAL_PLAN=Y
ANI_WB_LIST=NONE
```

Sub DP Dest InterLATA

The following Sub DP Dest interLATA CLI example is used in the [0+ InterLATA Call](#) routing example.

```
CLI>show sub-profile id=sp50
Reply : Success: Entry 1 of 1 returned.

ID=sp50
DIAL_PLAN_ID=dp50
LOCAL_PFX1_OPT=NR
TOLL_PFX1_OPT=RQ
POP_ID=50
OLI=0
EA_USE_PIC1=Y

CLI>show dial-plan id=dp50;digit-string=202
Reply : Success: Entry 1 of 1 returned.

ID=dp50
DIGIT_STRING=202
REQD_DIGITS=10
DEST_ID=interLATA
SPLIT_NPA=NONE
MIN_DIGITS=10
MAX_DIGITS=10
NOA=NATIONAL

CLI>show destination dest-id=interLATA
Reply : Success: Entry 1 of 1 returned.

DEST_ID=interLATA
CALL_TYPE=interLATA
ROUTE_TYPE=ROUTE
ROUTE_GUIDE_ID=TEST
ZERO_PLUS=Y
INTRA_STATE=Y
GAP_ROUTING=N
```

Sub DP Dest IntraLATA

The following Sub DP Dest IntraLATA CLI example is used in the [1+ IntraLATA Call](#) and [0+ IntraLATA Call](#) routing examples.

```
CLI>show sub-profile id=sp50
Reply : Success: Entry 1 of 1 returned.

ID=sp50
DIAL_PLAN_ID=dp50
LOCAL_PFX1_OPT=NR
TOLL_PFX1_OPT=RQ
POP_ID=50
OLI=0
EA_USE_PIC1=Y

CLI>show dial-plan id=dp50;digit-string=817
Reply : Success: Entry 1 of 1 returned.

ID=dp50
DIGIT_STRING=817
DEST_ID=toll
SPLIT_NPA=NONE
```

```

MIN_DIGITS=10
MAX_DIGITS=10
NOA=NATIONAL

CLI>show destination dest-id=toll
Reply : Success: Entry 1 of 1 returned.

DEST_ID=toll
CALL_TYPE=TOLL
ROUTE_TYPE=ROUTE
ROUTE_GUIDE_ID=TEST
ZERO_PLUS=N
INTRA_STATE=Y
GAP_ROUTING=N

```

Subscriber Test1

The following Subscriber Test1 CLI example is used in the [Basic Subscriber Routing, 1+ InterLATA Call, 1+ IntraLATA Call, 0+ InterLATA Call, and 0+ IntraLATA Call](#) routing examples.

```

CLI>show subscriber id=test1
Reply : Success: Entry 1 of 1 returned.

ID=test1
CATEGORY=INDIVIDUAL
NAME=c2421-227-2-1
STATUS=ACTIVE
BILLING_DN=2124540001
DN1=2124540001
PRIVACY=NONE
RING_TYPE_DN1=1
TERM_ID=aaln/S1/1
MGW_ID=c2421-227-2
PIC1=NONE
PIC2=NONE
PIC3=NONE
GRP=N
USAGE_SENS=Y
SUB_PROFILE_ID=sp50
TERM_TYPE=TERM
IMMEDIATE_RELEASE=N
TERMINATING_IMMEDIATE_REL=N
SEND_BILLING_DN=N

```

Subscriber Test2

The following Subscriber Test2 CLI example is used in the [Basic Subscriber Routing](#) and [Basic Trunk Routing](#) examples.

```
CLI>show sub id=test2
Reply : Success: Entry 1 of 1 returned.

ID=test2
CATEGORY=INDIVIDUAL
NAME=c2421-227-125-1
STATUS=ACTIVE
BILLING_DN=3124540001
DN1=3124540001
PRIVACY=NONE
RING_TYPE_DN1=1
TERM_ID=aaln/S1/1
MGW_ID=c2421-227-125
PIC1=NONE
PIC2=NONE
PIC3=NONE
GRP=N
USAGE_SENS=Y
SUB_PROFILE_ID=sp50
TERM_TYPE=TERM
IMMEDIATE_RELEASE=N
TERMINATING_IMMEDIATE_REL=N
SEND_BILLING_DN=N
```

Subscriber and Sub-Profile

The following Subscriber and Sub-Profile CLI example is used in the [Basic Subscriber Routing](#) and [1+ InterLATA Call](#) examples.

```
CLI>show subscriber id=test1
Reply : Success: Entry 1 of 1 returned.

ID=test1
CATEGORY=INDIVIDUAL
NAME=c2421-227-2-1
STATUS=ACTIVE
BILLING_DN=2124540001
DN1=2124540001
PRIVACY=NONE
RING_TYPE_DN1=1
TERM_ID=aaln/S1/1
MGW_ID=c2421-227-2
PIC1=NONE
PIC2=NONE
PIC3=NONE
GRP=N
USAGE_SENS=Y
SUB_PROFILE_ID=sp50
TERM_TYPE=TERM
IMMEDIATE_RELEASE=N
TERMINATING_IMMEDIATE_REL=N
SEND_BILLING_DN=N

CLI>show sub-profile id=sp50
Reply : Success: Entry 1 of 1 returned.
```

```
ID=sp50
DIAL_PLAN_ID=dp50
LOCAL_PFX1_OPT=NR
TOLL_PFX1_OPT=RQ
POP_ID=50
OLI=0
EA_USE_PIC1=Y
```

Trunk-grp 6969

The following Trunk-grp 6969 CLI example is used in the [Basic Trunk Routing](#) example.

```
CLI>show trunk-grp id=6969
Reply : Success: Entry 1 of 1 returned.
```

```
ID=6969
CALL_AGENT_ID=CA552
TG_TYPE=SS7
NUM_OF_TRUNKS=96
DPC=19-1-1
TG_PROFILE_ID=3
STATUS=OOS
DIRECTION=BOTH
SEL_POLICY=ASC
GLARE=SLAVE
ALT_ROUTE_ON_CONG=N
SIGNAL_PORTED_NUMBER=N
DIAL_PLAN_ID=dp50
DEL_DIGITS=0
OPER_STATUS=NF
TRAFFIC_TYPE=LOCAL
ANI_BASED_ROUTING=N
NO_ANSWER_TMR=185
```



CHAPTER 7

Preparing for Dial Plan Provisioning

Revised: December 9, 2008, OL-15637-04

Introduction

This chapter describes the tasks you need to perform before you can begin provisioning a dial plan. It also describes the tools you will use, and provides detailed information on the dial plan parameters and syntax conventions that you must be familiar with as you create your dial plan. This chapter includes the following sections:

- [Provisioning Prerequisites](#)
- [Provisioning Tools](#)
- [Creating a Dial Plan](#)



Note

The Cisco BTS 10200 Softswitch can use two servers, an active and a standby, for maximum reliability. The dial plans discussed in this chapter apply to both the active and standby servers. You need only create one dial plan and deploy that dial plan on both servers.

Provisioning Prerequisites

This section describes the tasks that must be completed and the information that you need before you start dial plan provisioning.

Prerequisite Tasks

Here are some steps you should perform before you use this dial plan guide.

-
- Step 1** Plan and diagram your network configuration in detail.
- A detailed network diagram is essential for the creation of a dial plan. *Refer to the appropriate solution overview and provisioning documentation for detailed information about a particular solution.*
- Step 2** Set up the Cisco BTS 10200 and install all required software.
- Before you start the planning process, you should prepare the Cisco BTS 10200 as described in the following manuals and database:
- [Site Preparation and Network Communications Requirements, Release 6.0.1](#)
 - [Network Site Survey for Software Installation Cisco BTS 10200 Softswitch](#)
 - Cisco BTS 10200 Softswitch Building Environment and Power Site Survey
 - Cisco BTS 10200 Softswitch Cabling, VLAN, and IRDP Procedures
 - Cisco BTS 10200 Softswitch CD Jumpstart Procedure for Solaris 10 Based Duplex Systems
 - [Cisco BTS 10200 Softswitch Application Installation, Release 6.0.1](#)
 - [Cisco BTS 10200 Softswitch Provisioning Guide, Release 6.0.1](#)
 - [Cisco BTS 10200 Softswitch CLI Database](#)
- Step 3** Complete all provisioning worksheets and site surveys, including filling in the names and IP addresses of all devices, attributes, and all other necessary information.
-

Prerequisite Information

Before you can complete the dial plan provisioning, you must collect the Cisco BTS 10200 dial plan provisioning information. [Table 7-1](#) provides space for you to enter the following information:

- **id**—dial plan identification
- **dest_id**—destination identification
- **digit_string**—dial plan digit string
- **max_digits**—maximum number of digits
- **min_digits**—minimum number of digits
- **noa**—nature of address
- **split_npa**—split number plan area
- **del_digits**—deleted digits
- **px_digits**—prefix digits

Add a Dial Plan Profile

The Dial Plan Profile (dial-plan-profile) table creates dial-plan-profile-ids before they are assigned to subscribers or trunk groups. The dial-plan-profile-id links digit-string entries in the Dial Plan table within a dial plan. Different dial-plan-profile-ids are assigned to subscribers and trunk groups. A dial-plan-id must be created in this table before entries can be added to the Dial Plan table.

Command	Purpose
add dial-plan-profile id=dpl; description=dialing plan profile id;	Adds a dial plan profile

Add a Dial Plan

A dial plan analyzes, screens, and routes a call based on dialed digits. The Dial Plan (dial-plan) table holds dial plan information for a specific type of call. It defines valid dialing patterns and determines call routing. All records that share a common dial-plan-profile-id are considered a dial plan.

Command	Purpose
add dial-plan id=sub; digit-string=469-255; noa=national; dest-id=local_call;	Adds a dial plan

Cisco BTS 10200 Provisioning Sequence

The order in which you provision dial plan tables is important. The following list identifies the recommended sequence for Cisco BTS 10200 provisioning:

1. Add a media gateway profile.
2. Add a media gateway.
3. Add a termination.
4. Add a destination.
5. Add a dial plan profile.
6. Add a dial plan.
7. Add a subscriber profile.
8. Add a subscriber.
9. Generate a DN2Subscriber.
10. Control a media gateway.
11. Equip a subscriber termination.
12. Control a subscriber termination.

For additional Cisco BTS 10200 provisioning information, refer to the [Cisco BTS 10200 Softswitch Provisioning Guide, Release 6.0.1](#).



CHAPTER 8

Provisioning Dial Plans

Revised: December 9, 2008, OL-15637-04

Introduction

This chapter provides detailed instructions for configuring Cisco BTS 10200 Softswitch dial plans through use of the command-line interface (CLI).

Provisioning a Dial Plan with the Command-Line Interface

This section provides the instructions for managing dial plans in the Cisco BTS 10200 configuration using the CLI. The CLI also allows you to perform show, add, change, and delete dial plans. The following subjects are discussed:

- [Dial Plan](#)
- [Dial Plan Profile](#)
- [International Dial Plan](#)
- [International Dial Plan Profile](#)
- [Custom Dial Plan Profile](#)
- [Custom Dial Plan](#)

Dial Plan

Dial plans analyze, screen, and route calls based on dialed digits. The Dial Plan (dial-plan) table holds dial plan information for a specific type of call. It defines valid dialing patterns and determines call routing. All records that share a common dial-plan-profile id are considered a dial plan. For additional information on the Dial Plan, refer to the [“Dial Plan” section on page 1-22](#).

Dial Plan Profile

The Dial Plan Profile (dial-plan-profile) table creates dial-plan-profile ids before they are assigned to subscribers or trunk groups. The dial-plan-profile id links digit-string entries in the Dial Plan table within a dial plan. Different dial-plan-profile ids are assigned to subscribers and trunk groups. A dial-plan-id must be created in this table before entries can be added to the Dial Plan table. For additional information on the Dial Plan Profile, refer to the [“Dial Plan Profile” section on page 1-22](#).

International Dial Plan

The International Dial Plan (intl-dial-plan) table holds international dial plan information for calls to regions outside the North American Numbering Plan (NANP). It contains the country code, minimum and maximum digits, the country name, and the route-grp-id. For additional information on the International Dial Plan, refer to the [“International Dial Plan” section on page 1-22](#).

International Dial Plan Profile

The International Dial Plan Profile (intl-dial-plan-profile) table is used to create unique IDs for international dial plans. This ID must be created before the International Dial Plan table can be provisioned. For additional information on the International Dial Plan Profile, refer to the [“International Dial Plan Profile” section on page 1-22](#).

Custom Dial Plan Profile

The Custom Dial Plan Profile (custom-dial-plan-profile) table defines custom dial plan IDs (CDP IDs) assigned to Centrex groups. For token names and description details for the Custom Dial Plan Profile table, refer to the [Cisco BTS 10200 Softswitch CLI Database](#).

Custom Dial Plan

The Custom Dial Plan (custom-dial-plan) table translates Centrex calls. If the result of a custom dial plan (CDP) is a POTS access code, call processing uses the POTS Dial Plan table to translate the digits dialed after the POTS access code. Speed call codes are provisioned in this table as nod=speed-call and fname=SC1D (or SC2D). Screening does not apply to speed dialing. For token names and description details for the Custom Dial Plan table, refer to the [Cisco BTS 10200 Softswitch CLI Database](#).



APPENDIX **A**

Call Types and Subtypes

Revised: December 9, 2008, OL-15637-04

This appendix describes the call types implemented in the Cisco BTS 10200 Softswitch.

Table A-1 *Valid Call Types and Subtypes*

Call Type	Subtype	Description
500		Service access code 500; use carrier to route the call.
700		700 SAC call, route via PIC or dialed CAC.
900		Service access code 900, use carrier to route the call.
976		Information services calls.
AIRLINES		Airlines information and reservation.
AMBULANCE		Ambulance.
ANA		Automatic number announcement.
BUSINESS		811- calls to business office.
CUT-THRU		Cut-thru calls (calls dialed as 101XXXX+#).
DA		411, NPA-555-1212 calls.
DA-TOLL		1+411, 1+NPA-555-1212 calls.
EMG	AMBULANCE	Ambulance.
	FIRE	Fire.
	NONE	911 calls.
	POLICE	Police.
FIRE		Fire.
INFO	AIRLINES	Airlines information and reservation.
	NONE	Information services calls.
	RAILWAYS	Railways information and reservation.
	TIME	Time of day reporting.
	TRAFFIC	Traffic accident report.
	TW	Time and temperature service.
	WEATHER	Weather report.

Table A-1 Valid Call Types and Subtypes (continued)

Call Type	Subtype	Description
INTERLATA		InterLATA call (uses PIC or dialed CAC).
INTL		International call type.
INTL-OPR		International operator.
INTL-WZ1		International call within World Zone 1.
LB-TEST		Loopback test call (108 test line).
LOCAL		Local call.
LRN		Location routing number.
MOBILE		Calls to mobile network.
NAS	NONE	Network access server (same as dynamic).
NATIONAL		National number. Use LSA and LATA tables to determine whether the call involved is a local, toll, or interLATA call.
NAT-OPR		National operator assisted calls.
NON-EMG		311 calls.
OPERATOR		Operator call.
PCS		Service access code 500; use carrier to route the call.
POLICE		Police.
PREMIUM		Service access code 900; use carrier to route the call.
RAILWAYS		Railways information and reservation.
REFER	NONE	
RELAY		711 calls.
REPAIR		611 calls.
SIP-TRIGGER	OHD	SIP trigger was invoked. Sub Call Type=OHD.
SIP-TRIGGER	TAT_1	Termination attempt trigger.
SIP-TRIGGER	TAT_2	Termination attempt trigger.
SIP-TRIGGER	NONE	Not applicable.
SVC-CODE		Generic service code call type. Used when none of the call types apply.
TANDEM		Tandem call between call agent and the next switch or call agent.
TEST-CALL	NLB-LINE-TEST	Network loop-back test call (netloop connection on terminating endpoint). The calling party number is of format <test-prefix><DN>.
	NCT-LINE-TEST	Network continuity test call on subscriber line. The calling party number is of format <test-prefix><DN>.

Table A-1 Valid Call Types and Subtypes (continued)

Call Type	Subtype	Description
	NLB-TRUNK-TEST	Network loop back test call on a trunking endpoint. The calling party number is of format <test-prefix><TG><TM>. The number of digits in the trunk group number (TG) and trunk member (TM) is determined by the test-trunk-grp-digits and test-trunk-member-digits values configured in the Call Agent Configuration table.
	NCT-TRUNK-TEST	Network continuity test call on a trunking endpoint. The calling party number is of format <test-prefix><TG><TM>. The number of digits in the TG and TM is determined by the test-trunk-grp-digits and test-trunk-member-digits values configured in the Call Agent Configuration table.
	TEST-ROUTE	Route the test call using <DN>. The calling party number is of format <test-prefix><TG><TM><DN>. The number of digits in the TG and TM is determined by the test-trunk-grp-digits and test-trunk-member-digits values configured in the Call Agent Configuration table.
	NONE	Test call dialed as 958/959-xxxx or 1xx.
	LB-TEST	TDM loopback test call (108 Test Line) based on test prefix. The calling party number is of format <test-prefix><TG><TM>. The number of digits in the TG and TM is determined by the test-trunk-grp-digits and test-trunk-member-digits values configured in the Call Agent Configuration table.
TIME	NONE	Time.
TOLL	NONE	IntraLATA toll call..
TOLL-FREE	NONE	Toll free call (800, 888, 877, 866, 855, 844...).
TRAFFIC	NONE	Traffic accident report.
TW	NONE	Time and temperature service.
UAN	NONE	Universal access number.
VACANT	NONE	Vacant code.
WEATHER	NONE	Weather report.



GLOSSARY

Revised: December 9, 2008, OL-15637-04

A

ABBR	abbreviated
ACQ	all calls query
ADDR	address
AIN	Advanced Intelligent Network
ALT	alternate
ALWD	allowed
ANI	automatic number identification
ANNC	announcement
ANSI	American National Standards Institute
ARQ	admission request
AS	application server
ASC	ascending
ASCII	Standard Code for Information Interchange
AT	access tandem
ATM	Asynchronous Transfer Mode

B

BKWD	backward
BLV	business line verification

C

CA	California
-----------	------------

CA	Call Agent
CAC	carrier access code
CAP	competitive access provider
CAS	channel associated signaling
CASC	cyclic ascending
CC	country code
CD-ROM	compact disk-read only memory
CdPN	called party number
CDP	custom dial plan
CDSC	cyclic descending
CHAR	character
CHG	charge
CLDPTY	called party
CLI	command-line interface
CLLI	Common Language Location Identifier
CND	calling number delivery
COMM	communication
CoS	class of service
COT	continuity test
CPN	calling party number
CTRL	control
CTX	Centrex

D

DA	directory assistance
DBM	database management
DDD	direct distance or domestic dialing
DEL	delete

DEST	destination
DIGMAN	digital manipulation
DN	directory number
DNIS	dialed number identification service
DOW	day of week
DOY	day of year
DP	dial plan
DP-ID	dial-plan identification
DPC	destination point code
DSC	descending order
DT	CAS DTMF endpoints
DTMF	dual tone multifrequency
E	
EMEA	Europe, Middle East, and Asia
EMG	emergency
EMS	Element Management System
ENUM	electronic number mapping
EPOM	Extensible Provisioning and Operations Manager
F	
FA	faulty
FA-RB	faulty remotely blocked
FAS	facility associated signaling
FGD	Feature Group D
FS	Feature Server

G

GAP	generic address parameter
GRP	group
GTD	Generic Transparency Descriptor
GW	gateway

H

HNPA	home numbering plan area
-------------	--------------------------

I

IAM	initial address message
ID	identification
IDDD	international direct dial domestic
INFO	information
INTL	international
INTL-OPR	international operator
ISDN	Integrated Services Digital Network
ISUP	ISDN user part
IT	ISUP trunk
ITP	IP transfer point
ITU	International Telecommunication Union
IVR	interactive voice response

L

LATA	local access transport area
LB	loop-back
LCR	least cost routing
LECOSS	local exchange carrier operations support system

LNP	local number portability
LRN	local routing number
LRU	least recently used
LS	load sharing
LSA	local service area
M	
MAX	maximum
MF	multifrequency
MGCP	Media Gateway Control Protocol
MGW	media gateway
MIN	minimum
MLHG	multi-line hunt group
MO	MF operator trunk
MRU	most recently used
MS	CAS MF endpoints
MSG	message
MT	MF terminating trunk
N	
NA	not applicable
NANP	North American Numbering Plan
NAS	network access server
NAT	national
NAT-OPR	national operator
NCT	network continuity test
NDC	national destination code
NF	non-faulty

NF-RB	non-faulty remotely blocked
NFAS	non-facility associated signaling
NLB	network loop-back
NOA	nature of address
NPA	numbering plan area
NS0	network specific (111 1000)
NS1	network specific (111 1001)
NS2	network specific (111 1010)
NS3	network specific (111 1011)
NS4	network specific (111 1100)
NS5	network specific (111 1101)
NS6	network specific (111 1110)
NTWK	network
NUM	number

O

OBCSM	originating basic call state machine
OCN	original called number
ODD	odd-numbered
ODR	origin dependent routing
OLI	originating line information
OPER	operational
OPR	operator

P

PBX	private branch exchange
PC	point code
PCS	personal communications services

PFX	prefix
PIC	point in call, presubscribed interexchange carrier
PKG	package
POP	point of presence
POTS	plain old telephone service
PSTN	public switched telephone network

Q

QOR	query on release
QOS	quality of service

R

RACF	remote activation of call forwarding
RAND	random
RDN	Redirecting Number Information Element
REL	release
RID	route identification
RN	routing number
RPF	registration and profiling tool
RR	round robin
RRQ	registration request

S

S1	severity 1
S2	severity 2
S3	severity 3
S4	severity 4
SAC	service access code

SCP	service control point
SEL	selection
SEQ	sequential
SIP	Session Initiation Protocol
SP	service provider
SS7	Signaling System 7
SUB	subscriber
SUB-OPR	subscriber operator
SUPP	supported
T	
TAC	Technical Assistance Center
TBCSM	terminating basic call system manager
TCL	tool command language
TDM	telecommunications data link monitor
TG	trunk group
TGN	trunk group number
TM	trunk member
TMR	timer
TNS	transit network selection
TOD	time of day
TSAP	transport service access point
TW	time weather call
U	
UAN	universal access number
URL	uniform resource locator

US United States
USA United States of America

V

VARCHAR variable character
VSC Vertical Service Code

