



## **Cisco BTS 10200 Softswitch ISDN Provisioning and Troubleshooting**

Software Release 5.0

**Revised: January 31, 2008**

### **Americas Headquarters**

Cisco Systems, Inc.  
170 West Tasman Drive  
San Jose, CA 95134-1706  
USA  
<http://www.cisco.com>  
Tel: 408 526-4000  
800 553-NETS (6387)  
Fax: 408 527-0883

Text Part Number: OL-12436-02

THE SPECIFICATIONS AND INFORMATION REGARDING THE PRODUCTS IN THIS MANUAL ARE SUBJECT TO CHANGE WITHOUT NOTICE. ALL STATEMENTS, INFORMATION, AND RECOMMENDATIONS IN THIS MANUAL ARE BELIEVED TO BE ACCURATE BUT ARE PRESENTED WITHOUT WARRANTY OF ANY KIND, EXPRESS OR IMPLIED. USERS MUST TAKE FULL RESPONSIBILITY FOR THEIR APPLICATION OF ANY PRODUCTS.

THE SOFTWARE LICENSE AND LIMITED WARRANTY FOR THE ACCOMPANYING PRODUCT ARE SET FORTH IN THE INFORMATION PACKET THAT SHIPPED WITH THE PRODUCT AND ARE INCORPORATED HEREIN BY THIS REFERENCE. IF YOU ARE UNABLE TO LOCATE THE SOFTWARE LICENSE OR LIMITED WARRANTY, CONTACT YOUR CISCO REPRESENTATIVE FOR A COPY.

The Cisco implementation of TCP header compression is an adaptation of a program developed by the University of California, Berkeley (UCB) as part of UCB's public domain version of the UNIX operating system. All rights reserved. Copyright © 1981, Regents of the University of California.

NOTWITHSTANDING ANY OTHER WARRANTY HEREIN, ALL DOCUMENT FILES AND SOFTWARE OF THESE SUPPLIERS ARE PROVIDED "AS IS" WITH ALL FAULTS. CISCO AND THE ABOVE-NAMED SUPPLIERS DISCLAIM ALL WARRANTIES, EXPRESSED OR IMPLIED, INCLUDING, WITHOUT LIMITATION, THOSE OF MERCHANTABILITY, FITNESS FOR A PARTICULAR PURPOSE AND NONINFRINGEMENT OR ARISING FROM A COURSE OF DEALING, USAGE, OR TRADE PRACTICE.

IN NO EVENT SHALL CISCO OR ITS SUPPLIERS BE LIABLE FOR ANY INDIRECT, SPECIAL, CONSEQUENTIAL, OR INCIDENTAL DAMAGES, INCLUDING, WITHOUT LIMITATION, LOST PROFITS OR LOSS OR DAMAGE TO DATA ARISING OUT OF THE USE OR INABILITY TO USE THIS MANUAL, EVEN IF CISCO OR ITS SUPPLIERS HAVE BEEN ADVISED OF THE POSSIBILITY OF SUCH DAMAGES.

CCVP, the Cisco Logo, and the Cisco Square Bridge logo are trademarks of Cisco Systems, Inc.; Changing the Way We Work, Live, Play, and Learn is a service mark of Cisco Systems, Inc.; and Access Registrar, Aironet, BPX, Catalyst, CCDA, CCDP, CCIE, CCIP, CCNA, CCNP, CCSP, Cisco, the Cisco Certified Internetwork Expert logo, Cisco IOS, Cisco Press, Cisco Systems, Cisco Systems Capital, the Cisco Systems logo, Cisco Unity, Enterprise/Solver, EtherChannel, EtherFast, EtherSwitch, Fast Step, Follow Me Browsing, FormShare, GigaDrive, GigaStack, HomeLink, Internet Quotient, IOS, iPhone, IP/TV, iQ Expertise, the iQ logo, iQ Net Readiness Scorecard, iQuick Study, LightStream, Linksys, MeetingPlace, MGX, Networking Academy, Network Registrar, *Packet*, PIX, ProConnect, RateMUX, ScriptShare, SlideCast, SMARTnet, StackWise, The Fastest Way to Increase Your Internet Quotient, and TransPath are registered trademarks of Cisco Systems, Inc. and/or its affiliates in the United States and certain other countries.

All other trademarks mentioned in this document or Website are the property of their respective owners. The use of the word partner does not imply a partnership relationship between Cisco and any other company. (0612R)

*Cisco BTS 10200 Softswitch ISDN Provisioning and Troubleshooting*  
Copyright © 2007 Cisco Systems, Inc. All rights reserved.



# CONTENTS

## Preface v

Modification History v

Industry Standards. vi

Obtaining Documentation, Obtaining Support, and Security Guidelines vi

---

## CHAPTER 1

### ISDN Provisioning 1-1

Description of Backhaul Set, Group, and Session 1-2

Network Side PRI 1-3

User Side PRI 1-4

Cisco BTS 10200 Provisioning 1-4

Provisioning 1-5

Place MGW, ISDN D-Channels, Trunk Groups and Trunks In Service 1-10

Verify Status of ISDN Services 1-11

Verify MGW Status 1-11

Verify D-Channel Status 1-11

Verify Trunk Group Status 1-12

Verify Trunk Termination and Trunk Status 1-12

International PRI Setup 1-14

ISDN Profiles 1-16

Maintenance Message Support 1-16

Customizing D-Channel Profiles 1-18

ISDN Timer Configuration Parameters 1-20

ISDN Features and Supplementary Services 1-20

Information Digit Feature 1-21

Calling and Connected Name Delivery 1-22

Calling Number Identification Service (CLIP/CLIR) 1-23

Redirecting Number Support 1-23

ISDN PRI PBX Variant Setup 1-24

Intertel 256 with NI2 1-25

Intertel 256 with DMS-100 1-25

Intertel 256 with 4ESS 1-25

Intertel 256 with 5ESS 1-25

Lucent Definity G3r with NI2 1-26

Lucent Definity G3r with DMS-100 1-26

Lucent Definity G3r with 5ESS 1-26

Nortel Northstar with NI2 1-27

Nortel Option 11 with NI2 1-27

Nortel Option 11 with DMS-100 1-27

Siemens Hicom 300 with NI2 1-27

Siemens Hicom 300 with DMS-100 1-27

Siemens Hicom 300 with 4ESS 1-28

Siemens Hicom 300 with 5ESS 1-28

Toshiba Strada DK424 with NI2 1-28

**CHAPTER 2**

**Multiple Trunk Groups on a Single ISDN D-Channel 2-1**

Provisioning 2-1

Sample Line Test Configuration for Multiple Trunk Groups on a Single ISDN D-Channel 2-3

**CHAPTER 3**

**ISDN Backhaul Support Using IUA/SCTP 3-1**

IUA/SCTP Protocols 3-1

Provisioning an IUA Trunk Group 3-2

**CHAPTER 4**

**Maintaining and Troubleshooting the ISDN System 4-1**

Status and Control Commands 4-1

How to Troubleshoot When the ISDN D-Channel Fails to Restore 4-4

Checking the Status of a Trunk Termination 4-7

    Trunk Static State Is Set to Locally Blocked 4-8

    Trunk Static State Is Set to TRNS 4-8

    Trunk Static State Is Set to RBLK 4-9

    Termination Status Is Faulty 4-9

    Cannot Make a Call 4-9

IUA Traces 4-10

Checking MGW Provisioning 4-11

    IOS Gateway 4-11

    IUA/SCTP Gateway 4-13

Additional CLI Verification 4-17

Maintenance of a Call Agent Connected to an ISDN Trunk Group 4-18

ISDN D-Channel and Trunk Group CLI Command Troubleshooting 4-18



## Preface

---

**Revised: January 31, 2008, OL-12436-02**

This document describes the ISDN provisioning and troubleshooting for the Cisco BTS 10200 Softswitch. This document is intended for use by service provider management, system administration, and engineering personnel who are responsible for designing, installing, provisioning, and maintaining networks that use the Cisco BTS 10200 Softswitch system.

## Modification History

### Feature History

Release	Modification
1.0	ISDN PRI was initially introduced.
3.5	ISDN PRI was enhanced to include certain PRI variants (PBX access) and selected PRI supplementary services.
4.1	-UNSUPP tokens were changed to -SUPP. Documentation change (08/25/2003)—Updated Figure 1-1 Removed the line “and in the FACILITY message in the network-to-user direction as an optional IE” from Table 1-1.
4.2	No change.
4.4.0	Added Generic and Info Digit features, revised Network Side and User Side graphics and content, reorganized provisioning content.
4.4.1	Added NFAS, and D-channel Backup provisioning and troubleshooting content.
4.5	No change.
5.0	Added status and control commands for D-channels and decoupled trunk group from the D-channel. Added support for multiple trunk groups in a single D-channel and ISDN backhauling using IUA/SCTP.

## Industry Standards.

Standards	Title
RFC 3057	RFC 3057— ISDN Q.921-User Adaptation Layer
RFC 2960	RFC 2960—Stream Control Transmission Protocol

## Obtaining Documentation, Obtaining Support, and Security Guidelines

For information on obtaining documentation, obtaining support, providing documentation feedback, security guidelines, and also recommended aliases and general Cisco documents, see the monthly *What's New* in Cisco Product Documentation, which also lists all new and revised Cisco technical documentation, at:

<http://www.cisco.com/en/US/docs/general/whatsnew/whatsnew.html>



# CHAPTER 1

## ISDN Provisioning

---

Revised: January 31, 2008, OL-12436-02

This chapter describes ISDN provisioning for the Cisco BTS 10200 Softswitch. It provides the procedures for turning up, managing, and troubleshooting ISDN signaling on the Cisco BTS 10200 Softswitch and voice gateways.

For SCTP/IUA ISDN Provisioning

The basic ISDN network elements and signaling connections are shown in [Figure 1-1](#). Standby elements in the figure are omitted for clarity.

**Figure 1-1** ISDN Network Elements

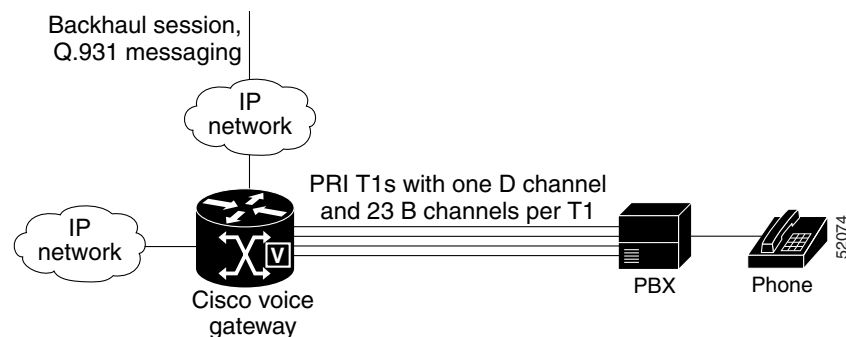

**Note**

The Cisco BTS 10200 Softswitch Call Agent (CA) supports multiple voice gateways, or PBXs.

---

## Description of Backhaul Set, Group, and Session

The backhaul session parameters used in provisioning are illustrated in [Figure 1-2](#). As shown in the figure, Call Agent Side A is connected to the media gateway (MGW) using the Group A signaling paths (Sessions A1 and A2), and is designated as primary. If one of these sessions goes down, the system uses the other session for signaling between Call Agent Side A and the MGW. There is no need for the Softswitch to switch over to Call Agent Side B. If the primary Call Agent goes down, then the Cisco BTS 10200 switches to the secondary Call Agent.

**Figure 1-2** Backhaul Set, Group, and Session

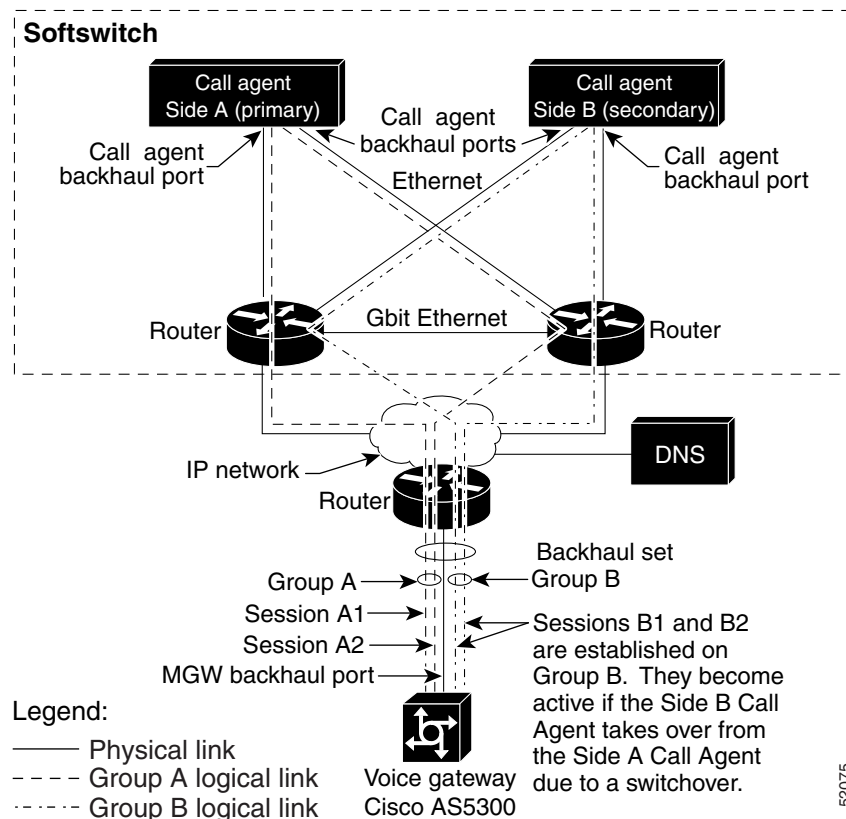

# Network Side PRI

The Network Side PRI feature allows the Cisco BTS 10200 Softswitch to communicate with PBXs. This feature provides support for the ISDN PRI Network Side basic call-control procedures as described in Q.931 ISDN Call Control Procedures. The network-side stack has the following PRI variants enabled:

- ISDN US NI2 PRI (TR 1268)
- ISDN Q931 PRI
- ISDN DMS
- ISDN ATT 4ESS PRI
- ISDN ATT 5ESS PRI

Figure 1-3 shows a sample PRI network-side configuration.

**Figure 1-3** PRI Network-Side Configuration

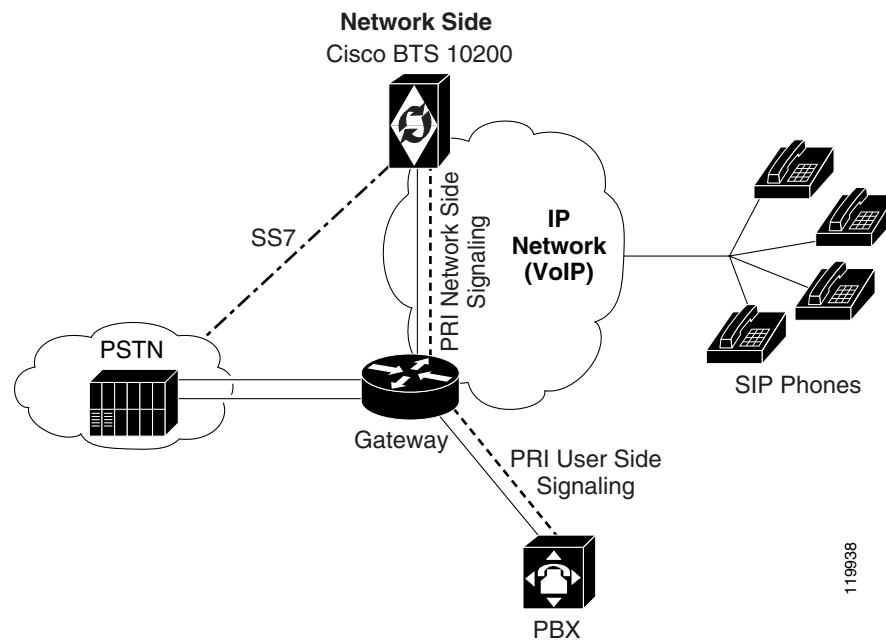

## User Side PRI

The User Side PRI feature allows provisioning when the Cisco BTS 10200 Softswitch does not support the SS7 variant of a particular country. This feature provides support for the ISDN PRI User Side basic call-control procedures as described in Q.931 ISDN Call Control Procedures. The user-side stack has the following PRI variants enabled:

- ISDN US NI2 PRI (TR 1268)
- ISDN Q931 PRI
- ISDN DMS
- ISDN ATT 4ESS PRI
- ISDN ATT 5ESS PRI

Figure 1-4 shows a sample PRI user-side configuration.

**Figure 1-4** PRI User-Side Configuration

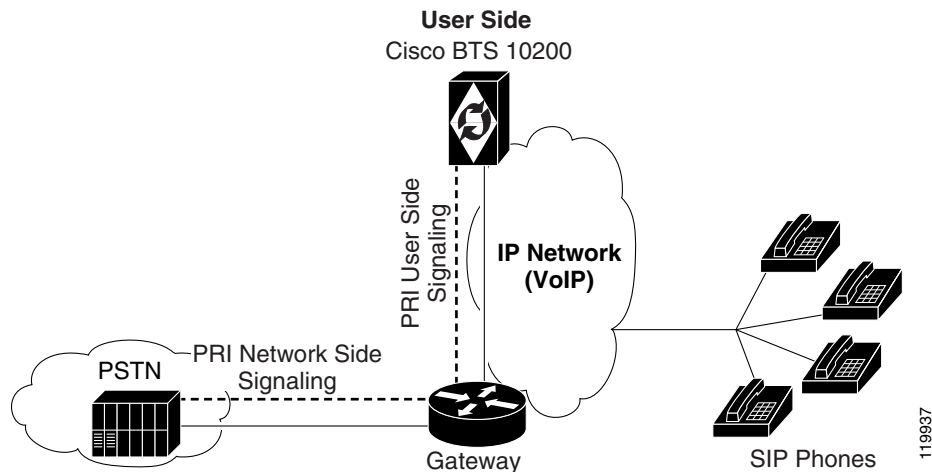

## Cisco BTS 10200 Provisioning

This section provides an overview of the Cisco BTS 10200 Softswitch provisioning steps. The basic Cisco BTS 10200 provisioning sequence is shown below.



### Note

These steps provision ISDN-specific data in the Cisco BTS 10200 Softswitch database. Referenced data tables, such as Dial Plan and Subscriber Profile must already be provisioned. Additional commands are also necessary to provision routing and translation for ISDN channels (see the *Cisco BTS 10200 Softswitch Command Line Interface Reference Guide*).

# Provisioning

This section provides the ISDN provisioning steps.

- See the *Cisco BTS Command Line Interface Reference Guide* for explanations of each token in the command.
- After entering each command, press the **Return (Enter)** key.
- See the [ISDN Profiles](#) section for information regarding profiles.
- Performing steps 1, 2 and 3 provisions ISDN FAS for ISDN backhaul using RUDP.
- Performing steps 1, 2 and 4 provisions ISDN NFAS for ISDN backhaul using RUDP, which includes D channel backup.
- See the [International PRI Setup](#) section for information on provisioning for International PRI.
- See the [ISDN PRI PBX Variant Setup](#) section for information on provisioning certain specific PBX variants.
- See [Chapter 2, “Multiple Trunk Groups on a Single ISDN D-Channel”](#) for provisioning multiple trunk groups on a single D-channel.
- See [Chapter 3, “ISDN Backhaul Support Using IUA/SCTP”](#) in Chapter 3 to provision ISDN backhaul for IUA/SCTP.



## Note

On a big, fast gateway (BFG), there is no concept of a slot number from a PRI backhaul perspective, although a BFG resides on a particular slot in the chassis. The architecture of a BFG is such that each slot acts as an independent gateway in itself. The Cisco BTS 10200 Softswitch addresses individual BFG cards by the card IP address—so the slot number is zero. Current CLI implementation uses a total of 16 bits with the D channel slot represented by 8 bits and the D channel port represented by 8 bits. To interface with a BFG, set the slot to 0 when the port is greater than 255 (8 bits).



## Note

The proprietary-supp token must be set to 8 when provisioning NI2.

The following steps provide the commands and examples for ISDN provisioning:

### Step 1

Log on to the active EMS by entering the following commands on a console that can communicate via IP with the active EMS.



## Note

To verify which EMS is currently active, log on to any EMS or CA/Feature Server (FS) machine as a root user, and enter the command **nodestat**. This displays the IP address of the active EMS. Then **exit**.

- Open a UNIX shell or XTerm window (or, in Windows, choose **Start > Run > Command prompt**).
- At the UNIX shell prompt, enter **ssh** and the IP address or domain name of the active EMS.
 

```
ssh -l <CLI username> ip address
```
- At the password prompt, enter the password for the CLI username.
 

```
<password for CLI username>
```

The system responds with a prompt.

**Step 2** Add the MGW and backhaul set. Refer to [Figure 1-5](#) for a sample configuration for backhaul session connections between a CA and a gateway.

- a. Add the MGW profile for the voice gateway. Multiple MGW profiles can be created for different media gateways per your configuration requirements.

```
add mgw-profile id=mgwprofile2; vendor=Cisco; packet-type=IP; mgcp-variant=NONE;
rbk-on-conn-supp=n; isdn=y; mgcp-erqnt-supp=n; mgcp-hairpin-supp=n;
mgcp-cmd-seq-supp=n; mgcp-version=MGCP_1_0;
```

- b. Add the MGW using the MGW profile created in Step 2a.

```
add mgw ID=mgw-isdn; tsap-addr=10.89.227.200; call-agent-id=CA146;
mgw-profile-id=mgwprofile2; type=MGW;
```

- c. Add the backhaul session set ID for the gateway using the MGW ID specified in Step 2b with the appropriate values for your system.

```
add backhaul-set SET-ID=backset1; MGW-ID=mgw-isdn; SET-NAME=set1;
```

- d. Add the Reliable User Data Protocol (RUDP) backhaul sessions for the gateway using the backhaul session set ID created in Step 2c and appropriate values configured on the gateway:

Information as seen on IOS Gateway

```
session group group1 10.89.225.223 9000 10.89.227.200 9000 0
session group group1 10.89.226.223 9001 10.89.227.200 9001 0
session group group2 10.89.225.224 9000 10.89.227.200 9000 0
session group group2 10.89.226.224 9001 10.89.227.200 9001 0
```

CLI associated with information seen on gateway:

```
add rudp-backhaul-session set-id=backset1; session-name=session1; group-name=group1;
call-agent-tsap-addr=10.89.225.223;
```

```
call-agent-backhaul-port=9000;mgw-tsap-addr=10.89.227.200; mgw-backhaul-port=9000;
```

```
add rudp-backhaul-session set-id=backset1; session-name=session2; group-name=group1;
call-agent-tsap-addr=10.89.226.223; call-agent-backhaul-port=9001;
mgw-tsap-addr=10.89.227.200; mgw-backhaul-port=9001;
```

```
add rudp-backhaul-session set-id=backset1; session-name=session3; group-name=group2;
call-agent-tsap-addr=10.89.225.224; call-agent-backhaul-port=9000;
mgw-tsap-addr=10.89.227.200; mgw-backhaul-port=9000;
```

```
add rudp-backhaul-session set-id=backset1; session-name=session4; group-name=group2;
call-agent-tsap-addr=10.89.226.224; call-agent-backhaul-port=9001;
mgw-tsap-addr=10.89.227.200; mgw-backhaul-port=9001;
```



**Note**

The call-agent-tsap-addr token must be a physical IP address.

**Figure 1-5 Sample Configuration for Backhaul Session Connections Between a CA and a Gateway**

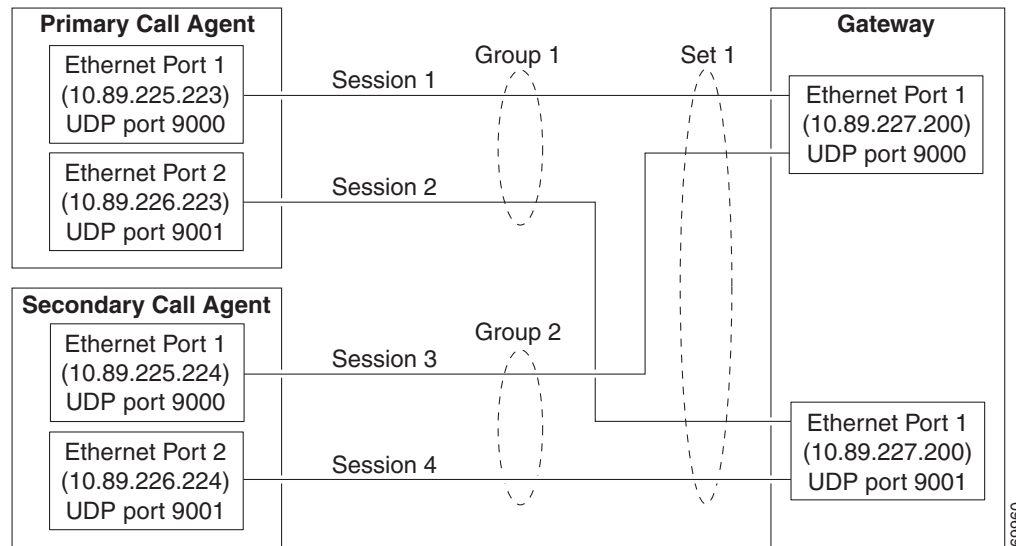

**Step 3** Configure PRI FAS. [Figure 1-6](#) shows a sample configuration for Facility Associated Signaling (FAS).



**Note** To configure PRI NFAS, go to [Step 4](#).

**Figure 1-6 Sample Configuration for FAS**

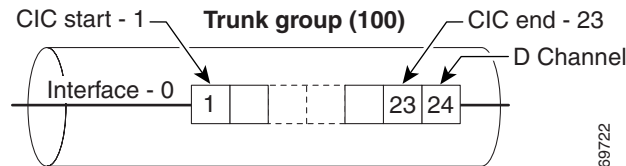

a. Add an ISDN D-channel profile with the `nfas-suppl` token set to N.

```
add isdn-dchan-profile id=NI2; description=dallas isdn dchan profile no.1;
type=swv-us-ni2-pri; interface-type=network; isdn-restart-pri-suppl=y;
isdn-restart-interface-suppl=y; isdn-service-suppl=n; isdn-restart-chan-suppl=y;
isdn-farend-init=n; isdn-query-suppl=n; nfas-suppl=n; bchan-neg-suppl=y; t-301=300;
t-302=10; t-303=4; t-305=30; t-308=4; t-309=90; t-310=10; t-316=30; t-321=20; t-322=4;
t-323=30;
```



**Note** See the “ISDN Profiles” section on [page 1-16](#) for more information.

b. Add the ISDN interfaces.

```
add isdn-intf isdn-dchan-id=100; intf=0;
```

c. Add the ISDN D channels using the backhaul session set ID added in Step 2c and ISDN interfaces added in Step 3b (where `dchan-port` refers to the DS1 span number used).

```
add isdn-dchan id=100; backhaul-type=RUDP; SET-ID=backset1; dchan-slot=0;
dchan-port=1; dchan-type=primary; dchan-intf=0; isdn-dchan-profile-id=NI2;
```

- d. Add an ISDN trunk group profile.

```
add isdn-tg-profile id=dallas1; chrg-num-supp=Y;
```

- e. Add the ISDN trunk groups using the ISDN trunk group profile added in Step 3d.

```
add trunk-grp id=100; call-agent-id=CA146; tg-type=ISDN; tg-profile-id=dallas1;
pop-id=1; glare=all; mgcp-pkg-type=T; dial-plan-id=dp1; isdn-dchan-id=100;
```



---

**Note** For ISDN trunk groups, the mgcp-pkg-type token must be set to T.

---

- f. Add the ISDN terminations using the MGW ID added in Step 2b.

```
add termination prefix=S4/DS1-1/; port-start=1; port-end=23; type=trunk;
mgw-id=mgw-isdn;
```

- g. Add the ISDN trunks using the trunk group profile added in Step 3d, the ISDN interface added in Step 3b, the MGW ID added in Step 2b, and the ISDN termination used in Step 3f.

```
add trunk cic-start=1; cic-end=23; tgn-id=100; mgw-id=mgw-isdn;
termination-prefix=S4/DS1-1/; termination-port-start=1; termination-port-end=23; intf=0;
```

- h. Add the subscriber, then link to the trunk group. See the *Cisco BTS 10200 Softswitch Provisioning Manual* for additional details. In the following example, the subscriber profile ID must already exist.

```
add subscriber id=pbx1@cisco.com; category=pbx; name=pbx1; status=active;
address1=1651 n glenville; address2=Richardson tx 75081; ss-number=643-77-1837;
billing-dn=972-233-9000; dn1=972-233-9000; ring-type-dn1=1; tgn-id=100;
sub-profile-id=dp1; term-type=none;
```

```
change trunk-grp id=100; main-sub-id=pbx1@cisco.com;
```

- i. Go to the “Place MGW, ISDN D-Channels, Trunk Groups and Trunks In Service” section on page 1-10.

**Step 4** Configure PRI NFAS. [Figure 1-7](#) shows a sample configuration for NFAS.





---

**Note** To perform an ISDN D-channel switchover, see the *Cisco BTS 10200 Command Line Interface Reference Guide*.

---

This step also creates and provisions a backup ISDN D channel.

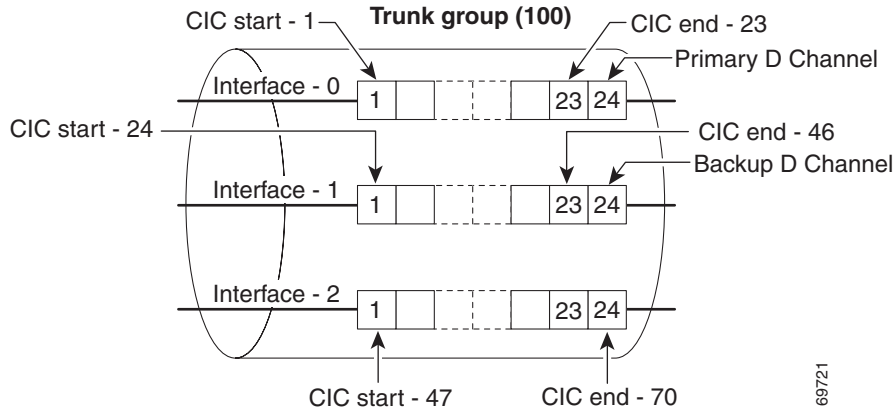
---

**Figure 1-7 Sample Configuration for NFAS**

- Add the ISDN D-channel profile with the `nfas-suppl` token set to `Y`.
 

```
add isdn-dchan-profile id=NI2; description=dallas isdn dchan profile no.1;
type=swv-us-ni2-pri; interface-type=network; isdn-restart-pri-suppl=y;
isdn-restart-interface-suppl=y; isdn-service-suppl=n; isdn-restart-chan-suppl=y;
isdn-farend-init=n; isdn-query-suppl=n; nfassuppl=y; bchan-neg-suppl=y; t-301=300;
t-302=10; t-303=4; t-305=30; t-308=4; t-309=90; t-310=10; t-316=30; t-321=20; t-322=4;
t-323=30;
```
- Add the ISDN interfaces.
 

```
add isdn-intf isdn-dchan-id=100; intf=0;
add isdn-intf isdn-dchan-id=100; intf=1;
add isdn-intf isdn-dchan-id=100; intf=2;
```
- Add the primary and backup ISDN D channels using the session set ID added in Step 2c and the ISDN interfaces added in Step 4b.
 

```
add isdn-dchan id=100; backhaul-type=RUDP; set-id=backset1; dchan-slot=0;
dchan-port=0; dchan-type=primary; dchan-intf=0; isdn-dchan-profile-id=NI2;

add isdn-dchan id=100; backhaul-type=RUDP; set-id=backset1; dchan-slot=0;
dchan-port=1; dchan-type=backup; dchan-intf=1; isdn-dchan-profile-id=NI2;
```
- Add an ISDN trunk group profile.
 

```
add isdn-tg-profile id=dallas1; chrg-num-suppl=Y;
```
- Add the ISDN trunk groups using the ISDN trunk group profile added in Step 4d.
 

```
add trunk-grp id=100; call-agent-id=CA146; tg-type=ISDN; tg-profile-id=ISDN;
pop-id=1; glare=ALL; mgcp-pkg-type=T; dial-plan-id=dpl1; isdn-dchan-id=100;
```
- Add the ISDN terminations using the MGW added in Step 2b.
 

```
add termination prefix=s0/ds1-0/; port-start=1; port-end=23; type=trunk;
mgw-id=mgw_isdn;

add termination prefix=s0/ds1-1/; port-start=1; port-end=23; type=trunk;
mgw-id=mgw_isdn;

add termination prefix=s0/ds1-2/; port-start=1; port-end=24; type=trunk;
mgw-id=mgw_isdn;
```

69721

- g. Add the ISDN trunks using the trunk group ID added in Step 4e, the ISDN interfaces added in Step 4b, the MGW added in Step 2b, and the termination prefix added in Step 4f.

```
add trunk cic-start=1; cic-end=23; tgn-id=100; mgw-id=mgw-isdn;
termination-prefix=s0/ds1-0/; termination-port-start=1;
termination-port-end=23; intf=0;

add trunk cic-start=24; cic-end=46; tgn-id=100; mgw-id=mgw-isdn;
termination-prefix=s0/ds1-1/; termination-port-start=1;
termination-port-end=23; intf=1;

add trunk cic-start=47; cic-end=70; tgn-id=100; mgw-id=mgw-isdn;
termination-prefix=s0/ds1-2/; termination-port-start=1;
termination-port-end=24; intf=2;
```

- h. Add the subscriber, then link the subscriber to the trunk group.

```
add subscriber id=pbx1@cisco.com; category=pbx; name=pbx1; status=active;
address1=1651 n glenville suite 200; address2=Richardson tx 75081;
ss-number=643-77-1837; billing-dn=972-233-9000; dn1=972-233-9000;
ring-type-dn1=1;tgn-id=100; sub-profile-id=dpl;

change trunk-grp id=100; main-sub-id=pbx1@cisco.com;
```

## Place MGW, ISDN D-Channels, Trunk Groups and Trunks In Service

This procedure places the MGW and the ISDN trunk groups in service. This does not automatically place the trunk terminations in service. The trunk terminations must be equipped and placed in service separately.

- 
- Step 1** Place the MGW in service.
- ```
control mgw id=mgw-isdn; target-state=INS; mode=forced;
```
- Step 2** Place the ISDN D-channel in service.
- ```
control isdn-dchan id=100; dchan-type=PRIMARY; target_state=ins;
```
- Step 3** Place the ISDN trunk group in service.
- ```
control trunk-grp id=100; mode=forced; target_state=ins;
```
- Step 4** Equip the trunk-terminations.
- ```
equip trunk-termination tgn-id=100; cic=all;
```
- Step 5** Place the trunk-terminations in service.
- ```
control trunk-termination tgn-id=100; mode=forced; target-state=ins; cic=all;
```
-

## Verify Status of ISDN Services

This procedure verifies that the MGW, MGW terminations, trunks, ISDN D-channels and trunk groups are in service. When the system reports that both the administrative and operational states are in service, it means that ISDN signaling is enabled in the network served by this Cisco BTS 10200 Softswitch. If the system reports any administrative or operational states as out of service (OOS), or not functioning, follow the specified troubleshooting steps in the [“Obtaining Documentation, Obtaining Support, and Security Guidelines”](#) section on page vi to correct the problem.

**Note**

For a description of all administrative and operational states reported by the *status* command, see the *Cisco BTS 10200 Softswitch Operations Manual*.

## Verify MGW Status

Perform the following steps to verify the MGW status:

**Step 1** Check the MGW status.

```
status mgw id=mgw-isdn;
```

```
Reply : Success:  
MGW ID -> mgw-isdn  
RESULT -> ADM configure result in success  
REASON -> ADM executed successful  
ADMIN STATE -> ADMIN_INS  
OPER STATE -> Media gateway in working status
```

**Step 2** If the administrative state is ADMIN\_INS and the operational state is working status, the CA-to-MGW connection is functioning properly. Proceed to the [“Verify D-Channel Status”](#) section on page 1-11.

Otherwise, stop and perform troubleshooting in accordance with the [“Obtaining Documentation, Obtaining Support, and Security Guidelines”](#) section on page vi.

## Verify D-Channel Status

Perform the following steps to verify the D-channel status:

**Step 1** Verify the D-channel status.

```
status isdn-dchan id=100; dchan-type=PRIMARY;
```

**Step 2** If the administrative state is ADMIN\_INS and the operational state is in-service, then signaling is functioning properly on this D-channel. Proceed to the [“Verify Trunk Group Status”](#) section on page 1-12.

Otherwise, stop and perform troubleshooting in accordance with the [“Obtaining Documentation, Obtaining Support, and Security Guidelines”](#) section on page vi.

## Verify Trunk Group Status

Perform the following steps to verify the trunk group status:

- 
- Step 1** Verify the trunk group status.
- ```
status trunk-grp id=100;
```
- Step 2** If the administrative state is ADMIN\_INS and the operational state is in-service, signaling is functioning properly on this trunk group. Proceed to the [“Verify Trunk Termination and Trunk Status”](#) section on page 1-12.
- Otherwise, stop and perform troubleshooting in accordance with the [“Obtaining Documentation, Obtaining Support, and Security Guidelines”](#) section on page vi.
- 

## Verify Trunk Termination and Trunk Status

Perform the following steps to verify the trunk termination and trunk status:

- 
- Step 1** Verify the trunk termination and trunk status. The following command queries both the trunk termination status and trunk (channel) status:

```
status trunk-termination tgn-id=100; cic=8;
```

```
Reply : Success:
RESULT -> ADM configure result in success
REASON -> ADM executed successful
TGN ID -> 100
CIC -> 8
TERM ADMIN STATE -> ADMIN_INS
TERM OPER STATE -> Termination is idle
TERM REASON -> No fault reason available
TRUNK STATIC STATE -> ACTV
TRUNK DYNAMIC STATE -> TRNS
TRUNK REASON -> NON_FAULTY
```

The command in the following example queries trunk termination status and trunk status for channels 1 to 4:

```
status trunk-termination tgn-id=100; cic=1-4;
```

```
Reply : Success: Entries 1-4 of 4 returned.

TGN_ID -> 100
CIC -> 4
RESULT -> ADM configure result in success
REASON -> ADM executed successful
TERM_ADMIN_STATE -> ADMIN_INS
TERM_OPER_STATE -> Termination is idle
TERM_REASON -> No fault reason available
TRUNK_STATIC_STATE -> ACTV
TRUNK_DYNAMIC_STATE -> IDLE
TRUNK_REASON -> NON_FAULTY
```

```
TGN_ID -> 100
CIC -> 3
RESULT -> ADM configure result in success
REASON -> ADM executed successful
TERM_ADMIN_STATE -> ADMIN_INS
TERM_OPER_STATE -> Termination is idle
TERM_REASON -> No fault reason available
TRUNK_STATIC_STATE -> ACTV
TRUNK_DYNAMIC_STATE -> IDLE
TRUNK_REASON -> NON_FAULTY
```

```
TGN_ID -> 100
CIC -> 2
RESULT -> ADM configure result in success
REASON -> ADM executed successful
TERM_ADMIN_STATE -> ADMIN_INS
TERM_OPER_STATE -> Termination is idle
TERM_REASON -> No fault reason available
TRUNK_STATIC_STATE -> ACTV
TRUNK_DYNAMIC_STATE -> IDLE
TRUNK_REASON -> NON_FAULTY
```

```
TGN_ID -> 100
CIC -> 1
RESULT -> ADM configure result in success
REASON -> ADM executed successful
TERM_ADMIN_STATE -> ADMIN_INS
TERM_OPER_STATE -> Termination is idle
TERM_REASON -> No fault reason available
TRUNK_STATIC_STATE -> ACTV
TRUNK_DYNAMIC_STATE -> IDLE
TRUNK_REASON -> NON_FAULTY
```

**Step 2** The system is functioning properly if all of the following conditions are shown in the system response:

- TERM\_ADMIN\_STATUS is ADMIN\_INS
- TERM\_OPER\_STATUS is TERMINATION IS IDLE
- TERM\_REASON -> No fault reason available
- TRUNK\_STATIC\_STATE is ACTV
- TRUNK\_DYNAMIC\_STATE is IDLE
- TRUNK\_REASON -> NON\_FAULTY

If all of these conditions are shown in the system response, you have completed this procedure.

Otherwise, perform troubleshooting in accordance with the [“Obtaining Documentation, Obtaining Support, and Security Guidelines”](#) section on page vi.

## International PRI Setup

This section describes how to provision the Cisco BTS 10200 Softswitch for International PRI. International PRI uses the International Telecommunications Union (ITU)/European Telecommunication Standards Institute (ETSI) standard.

**Note** ITU/ETSI uses a primary net-5 switch.

**Step 1** Configure PRI FAS.

Figure 1-8 shows a sample configuration for Facility Associated Signaling (FAS).

**Figure 1-8** Sample Configuration for FAS

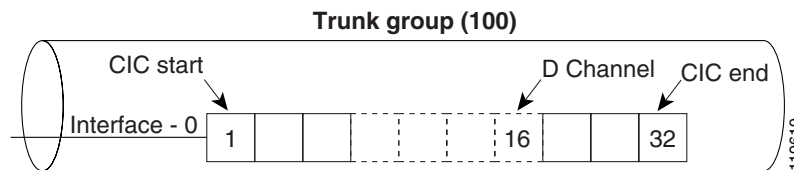

- a. Add ISDN D-channel profile with the `nfas-supp` token set to N.

```
add isdn-dchan-profile ID=NI2; description=dallas isdn dchan profile no.1;
type=SWV-ETSI-PRI; interface-type=network; isdn-restart-pri-supp=Y;
isdn-restart-interface-supp=y; isdn-service-supp=n; isdn-restart-chan-supp=y;
isdn-farend-init=n; isdn-query-supp=n; nfass-supp=n; bchan-neg-supp=y; t-301=300;
t-302=10; t-303=4; t-305=30; t-308=4; t-309=90; t-310=10; t-316=30; t-321=20; t-322=4;
t-323=30;
```



**Note** See the “ISDN Profiles” section on page 1-16 for more information.

- b. Add the ISDN interfaces.

```
add isdn-intf isdn-dchan-id=100; INTF=0;
```

- c. Add the ISDN D channels using the backhaul session set ID added in Step 2c in the “Provisioning” section on page 1-5 and the ISDN interfaces added in Step 1b.

```
add isdn-dchan id=100; backhaul-type=RUDP; set-id=backset1; DCHAN-SLOT=0;
DCHAN-PORT=1; DCHAN-TYPE=primary; DCHAN-INTF=0; isdn-dchan-profile-id=NI2;
```

- d. Add an ISDN trunk group profile.

```
add isdn-tg-profile id=dallas1; chrg-num-supp=Y;
```

- e. Add the ISDN trunk groups using the ISDN trunk group profile added in Step 1d.

```
add trunk-grp id=100; call-agent-id=CA146; tg-type=ISDN; tg-profile-id=ISDN1;
glare=all; mgcp-pkg-type=T; dial-plan-id=dp1; dial-plan-id=dp1; isdn-dchan-id=100;
```



**Note** For ISDN trunk groups, the `mgcp-pkg-type` token must be set to T.

- f. Add ISDN terminations using the MGW-ID added in Step 2b in the “Provisioning” section on page 1-5.

```
add termination PREFIX=S4/DS1-1/; PORT-START=1; PORT-END=15; TYPE=trunk;
MMGW-ID=mgw-isdn;
add termination PREFIX=S4/DS1-1/; PORT-START=17; PORT-END=32; TYPE=trunk;
MGW-ID=mgw-isdn;
```



---

**Note** Port 16 is reserved as the D channel. Do not add a termination and trunk for port 16.

---

- g. Add the ISDN trunks using the tgn-id added in Step 1e, the isdn-intf added in Step 1b, the termination-prefix used in Step 1f and the mgw-id added in Step 2b in the “Provisioning” section on page 1-5.

```
add trunk CIC-START=1; CIC-END=15; TGN-ID=100; MGW-ID=mgw-isdn;
TERMINATION-PREFIX=S4/DS1-1/; TERMINATION-PORT-START=1;TERMINATION-PORT-END=15;INTF=0;

add trunk CIC-START=17; CIC-END=32; TGN-ID=100; MGW-ID=mgw-isdn;
TERMINATION-PREFIX=S4/DS1-1/;
TERMINATION-PORT-START=17;TERMINATION-PORT-END=32;INTF=0;
```

- h. Add the subscriber, then link to the trunk group.

```
add subscriber id=<subscriber ID>; category=pbx; name=<name for PBX>; status=active;
address1=<street address>; address2=<city, state, zip code>; ssnnumber=<Social Security
number of main subscriber, if available>; sip-url=//<gateway domain name>;
billing-dn=<phone number to be billed>; dn1=<phone number of main subscriber>;
ring-type-dn1=<audible ringing type>;tgn-id=<TG ID number>; sub-profile-id=<ID of
subscriber-profile table for this subscriber>;
```

- i. Link to the trunk group.

```
change trunk-grp id=<TG ID number>; main-sub-id=<ID of main subscriber in subscriber
table>;
```

---

# ISDN Profiles

This section describes the supported ISDN profiles.

## Maintenance Message Support

This section describes the ISDN D-channel profile parameters, which hold information about the ISDN D-channels. These parameters are used to configure the Call Agent to interact with various types of PBXs having different configurations (for example, FAS), initialization procedures (Service or Restart), supporting different call-control or maintenance timer values, and so forth.

The following definitions and meanings apply:

- The Call Agent can send restart messages to a PBX during trunk group initialization (restoral). The restart message can be any of the following:
  - One for all interfaces (all B channels on all T1 interfaces)
  - One for each interface (all B channels on a specified T1 interface)
  - A separate restart message for individual (indicated) B channels
- The PBX can support sending service messages to the Call Agent.
  - Support by the PBX means the PBX takes action on service messages from the Call Agent and sends an acknowledgment message back to the Call Agent.
  - Nonsupport by the PBX means the PBX does not send an acknowledgment message back to the Call Agent.
- Maintenance message support using service and restart messages handles the protocol discriminator for national coding (0x43). Unsolicited service acknowledgment messages are also handled, including proper update of the trunk or channel states.

The ISDN D-channel profile is provisioned using the CLI. See the *Cisco BTS 10200 Command Line Interface Reference Guide* for additional information. The following tokens configure the Call Agent to communicate properly with the PBX:

- ISDN-RESTART-PRI-SUPP
  - If YES—The CA sends a restart message for all interfaces (Restart Class 7).
  - If NO—The PBX does not support a restart message for all interfaces (Restart Class 7). The CA will not send a “Restart All Interfaces” message.
- ISDN-RESTART-INTERFACE-SUPP
  - If YES—The PBX supports a restart message for single interface (Restart Class 6). The CA sends a single restart message for an individual interface.
  - If NO—The PBX does not support a restart message for a single interface (Restart Class 6).
- ISDN-SERVICE-SUPP
  - If NO—The PBX does not support service messages (B-channel availability). The CA sends a single service message for an individual channel.
  - If YES—The PBX supports service messages (B-channel availability).
- ISDN-RESTART-CHAN-SUPP
  - If YES—The CA sends single restart messages for individual channels (Restart Class 0).

If NO—The CA does not send single restart messages for individual channels (Restart Class 0).

- ISDN-FAREND-INIT—Allows PBX to bring far end in-service.
  - If YES—The CA sets B channels to Remote Block (RBLK) and waits for the remote PBX to send restart and service messages.
  - If NO—The CA performs an initialization or restoral procedure (sends RESTART or SERVICE messages)
- ISDN-QUERY-SUPP—Allows the CA to send ISDN status enquiry message to audit active calls.
  - If YES—The PBX supports status enquiry messages.
  - If NO—The PBX does not support status enquiry messages.



---

**Note** This value must be set correctly; otherwise, all calls will be lost during switchover.

---

The following cases illustrate some scenarios using the tokens listed above.

-----

Case 1: CA sends RESTART All Interface (Restart Class 7), a single restart for all interfaces in a PRI group.

ISDN-RESTART-PRI-SUPP=YES

-----

Case 2: CA sends RESTART Single Interface (Restart Class 6), a single restart for each interface in the PRI group.

ISDN-RESTART-PRI-SUPP=NO  
ISDN-RESTART-INTERFACE-SUPP=YES

-----

Case 3: CA sends a SERVICE Message for each B channel in each interface of the PRI group.

ISDN-RESTART-PRI-SUPP=NO  
ISDN-RESTART-INTERFACE-SUPP=NO  
ISDN-SERVICE-SUPP=YES

-----

Case 4: CA sends RESTART Single Channel (Restart Class 0), a single restart for each B-channel in each interface of the PRI group.

ISDN-RESTART-PRI-SUPP=NO  
ISDN-RESTART-INTERFACE-SUPP=NO  
ISDN-SERVICE-SUPP=NO  
ISDN-RESTART-CHAN-SUPP=YES

-----

Case 5: CA does not send any message and the remote side is responsible for initialization.

```
ISDN-RESTART-PRI-SUPP=NO
ISDN-RESTART-INTERFACE-SUPP=NO
ISDN-SERVICE-SUPP=NO
ISDN-RESTART-CHAN-SUPP=NO
ISDN-FAREND-INIT=YES
```

-----

Case 6: CA does not send any message and no initialization is required for either side.

```
ISDN-RESTART-PRI-SUPP=NO
ISDN-RESTART-INTERFACE-SUPP=NO
ISDN-SERVICE-SUPP=NO
ISDN-RESTART-CHAN-SUPP=NO
ISDN-FAREND-INIT=NO
```

-----

## Customizing D-Channel Profiles

To turn up a new D-channel with a new ISDN D-channel profile, perform the following steps:

- 
- Step 1** Determine whether PBX supports the service message:
- a. Set the following tokens in the isdn-dchan-profile to:
 

```
isdn-service-supp=y;
isdn-restart-chan-supp=n;
isdn-restart-interface-supp=n;
isdn-farend-init=n;
isdn-restart-pri-supp=n;
```
  - b. Control the D-channel out of service, then back in service.
  - c. Check the status of the trunk terminations within 30 seconds of restoring the d-channel group.
    - If the operational state for the trunks is TRANS, the service message is not supported by the PBX (set isdn-service-supp=n;).
    - If the operational state is IDLE, the service message is supported by the PBX (set isdn-service-supp=y;).
- Step 2** Determine whether PBX supports the restart message for a particular bearer channel:
- a. Set the following tokens in the isdn-dchan-profile to:
 

```
isdn-service-supp=<specify Y/N depending on whether service is supported>;
isdn-restart-chan-supp=y;
isdn-restart-interface-supp=n;
isdn-farend-init=n;
isdn-restart-pri-supp=n;
```

- b. Control the D-channel out of service, then back in service.
  - c. Check the status of the trunk terminations.
    - If the operational state TRANS for the trunks is TRANS, the restart channel message is not supported by the PBX (set `isdn-restart-chan-supp=n`);
    - If the operational state is IDLE, then the restart channel message is supported by the PBX (set `isdn-restart-chan-supp=y`);
- Step 3** Determine whether the PBX supports restart for the whole interface:
- a. Set the following tokens in the `isdn-dchan-profile` to:
    - `isdn-service-supp=whatever`;
    - `isdn-restart-chan-supp=whatever`;
    - `isdn-restart-interface-supp=y`;
    - `isdn-farend-init=n`;
    - `isdn-restart-pri-supp=n`;
  - b. Control the D-channel out of service, then back in service.
  - c. Check the status of the trunk terminations.
    - If the operational state for terminations is TRANS, the restart interface message is not supported by the PBX (set `isdn-restart-interface-supp=n`);
    - If the operational state is IDLE, the restart interface message is supported by the PBX (set `isdn-restart-interface-supp=y`);
- Step 4** Determine whether the PBX supports the query message. The `ISDN-QUERY-SUPP` flag in the `isdn-tg-profile` indicates whether the PBX supports the ISDN query message.
- If this flag is NO (default), the query message is not supported by the PBX.
  - If this flag is YES, the query message is supported by the PBX.
  - If you do not know the answer to whether the PBX supports the query message, then set `ISDN-QUERY-SUPP=N`;
- 

See the [“Obtaining Documentation, Obtaining Support, and Security Guidelines”](#) section on page vi for more troubleshooting information.

## ISDN Timer Configuration Parameters

The timer default values for the command-line interface (CLI) are set to default values required per the network side. There are minor differences in the timer values of user-side timer versus network-side timers, and these can be fine-tuned per user requirements. [Table 1-1](#) compares the timer values of network-side and user-side state machine as specified in Q.931 and as implemented in the Cisco BTS 10200 Softswitch.

**Table 1-1 Configuration (Protocol) Timers**

Timer Number	BTS Default	User Side	Network Side
T301	300	>180	>180
T302	10	15	10–15
T303	4	4	4
T304	20	30	20
T305	30	30	30
T306	60	—	30
T307	3	—	180
T308	4	4	4
T309	90	90	90
T310	10	30–120	10
T312	— (T303 restarted instead)	—	6
T313	Not implemented	4	—
T314	Not implemented	4	4
T316	30	120	120
T317	Not implemented	< 120	< 120
T318	Not applicable for PRI	4	—
T319	Not applicable for PRI	4	—
T320	Not implemented	—	30
T321	20	30	30
T322	4	4	4
T323	30	30	30

## ISDN Features and Supplementary Services

ISDN features and supplementary services include the following:

- [Information Digit Feature](#)
- [Calling and Connected Name Delivery](#)
- [Calling Number Identification Service \(CLIP/CLIR\)](#)
- [Redirecting Number Support](#)

## Information Digit Feature

The Information Digit feature provides functionality to receive and deliver originating line information (OLI or II digits) collected from an originating switch (or provisioned in the Cisco BTS 10200 Softswitch for local subscribers) to the far-end. The Nortel DMS variant of the ISDN PRI protocol supports using the Generic Digits Information element (Type of Digit = 4) to carry information such as Info Digits.

If Info Digits (Type of Digits = 4) are received from an incoming ISDN trunk group, these digits are considered as OLI and are used for policy-based routing. The OLI information can also be used for digit manipulation.

The processing of Generic Digits is controlled using the configurable GENDIGITS-IE-SUPP flag in the ISDN D-Channel Profile table for an incoming trunk group. If this is configured as N, the Cisco BTS 10200 Softswitch ignores and drops the Generic Digits parameter in the SETUP message.

If GENDIGIT-IE-SUPP is configured as Y, the Cisco BTS 10200 Softswitch decodes and processes the Generic Digits IE from any code set if received.

**Note**

---

The GENDIGITS-IE-CODESET flag in the ISDN D-Channel Profile table is not applicable to the receiving trunk group.

---

The following new ISDN D-Channel Profile table tokens are used to provision Generic Digits:

- gendigit-ie-supp
- gendigit-ie-codeset
- gendigit-tod-infodigit

The following example shows how to provision new generic digit tokens:

```
add isdn-dchan-profile id=dms-250; type=swv-dms-pri; interface-type=network;  
gendigit-ie-supp=y; gendigit-ie-codeset=6; gendigit-tod-infodigit=4;
```

Because the Info Digits information is associated with a charge number, whether the information is sent out as Info Digits depends on following factors:

- If the send-bdn-as-cpn or send-bdn-for-emg tokens are set to Y for the main subscriber entry configured for an incoming trunk group (which can be CAS, ISDN, H323 or SIP), the Cisco BTS 10200 Softswitch sends the OLI configured in the incoming Subscriber table entry as Info Digits.
- If the billing-dn token is configured for a main subscriber entry for an incoming trunk group (which can be CAS, ISDN, H323 or SIP), the Cisco BTS 10200 Softswitch sends the OLI configured in the incoming Subscriber table entry as Info Digits.
- If the OLI is available in a new call message from an incoming trunk group (which can be received as Generic Digits in ISDN or OLI in SS7), the Cisco BTS 10200 Softswitch passes the OLI received in the incoming message to the outgoing SETUP message.
- If the main Subscriber entry is configured for the incoming trunk group, the Cisco BTS 10200 Softswitch sends the OLI configured in the incoming Subscriber table as Info Digits.
- If none of the configurations in the above bullets occurred, the Cisco BTS 10200 Softswitch does not send any Info Digits.

If the `gendigits-ie-supp` token in an outgoing ISDN D-Channel Profile is configured as `Y` and the `gendigit-tod-infodigit` token is nonzero, the Cisco BTS 10200 Softswitch sends a setup message with OLI in the Generic Digits IE (type of digits=`GENDIGIT-TOD-INFODIGIT` configured in the outgoing ISDN D-Channel Profile).

If the `gendigits-ie-supp` token is configured as `N` in the outgoing ISDN D-Channel Profile, or if the `gendigits-tod-infodigits` token is configured as `0` in the outgoing ISDN D-Channel Profile, no Generic Digits IE is sent out.

The encoding of Generic Digits is always IA5. If a single I (single-digit Info Digit) is received in an incoming trunk group, the Cisco BTS 10200 Softswitch pads it with 0 and encodes it as II.

The code set in which a Generic Digits IE is sent is controlled using the `gendigits-ie-codeset` token in an outgoing ISDN D-Channel Profile.

## Calling and Connected Name Delivery

Calling Name (CNAME) delivery is a supplementary service that allows identification of a calling, or connected, name for PRI interfaces. It allows calls flowing through a Cisco BTS 10200 Softswitch ISDN virtual gateway to pass the calling, or connected, name data between the ISDN adapter and the internal signaling adapter interface (SAI) to the basic call module (BCM). It is configured using the ISDN D-Channel Profile table. [Table 1-2](#) describes the variants, messages, and IEs used for transporting a calling name IE.

**Table 1-2** Variants, Messages, and IEs used for Transporting a Calling Name IE

Switch Type	Messages	IEs	Comments
DMS-100 PRI type= swv-dms-pri	NOTIFY	DISPLAY IE Sent if: disp-ie-supp=y; cname-encode- method=protocol;	Display IE is supported in codeset0 as an optional IE in both user-to-networks and network-to-user directions.  <b>Note</b> If <code>cname-encode-method=raw-display</code> , no Display IE is sent in a NOTIFY message.
DMS-100 PRI type=swv-dms-pri	SETUP	DISPLAY IE Sent if: disp-ie-supp=y; cname-encode- method=protocol/ raw-disp;	Display IE is supported in codeset0 as an optional IE in both user-to-networks and network-to-user directions.  The raw display value overrides the standard DMS protocol use of DISPLAY IE. When <code>cname-encode-method=raw-disp</code> , calling name is carried in a Display IE as a null terminated ASCII string.

**Table 1-2** Variants, Messages, and IEs used for Transporting a Calling Name IE (continued)

Switch Type	Messages	IEs	Comments
NI PRI type=swv-us-ni2-pri	FACILITY, SETUP	FACILITY IE Sent if:  facil-ie-supp=y;  cname-encode- method=protocol;  DISPLAY IE Sent if:  disp-ie-supp=y;  cname-encode- method=raw-disp;	Facility IE carrying Cname is supported in the SETUP message in both the user-to-networks and network-to-user directions as an optional IE. The Facility IE is ASN.1 encoded.  The raw display value overrides the standard use of Facility IE. When cname-encode-method=raw-disp, calling, or connected, name is carried in a Display IE as a null terminated ASCII string.
AT&T 4ESS/5ESS PRI type= swv-4ess or type=swv-5ess-pri	SETUP, CONNECT	DISPLAY IE Sent if:  disp-ie-supp=y; cname-encode- method=raw-disp	Calling, or called, name functionality is not supported by the standard in either a Display IE, or a Facility IE.  However, if the raw display cname-encode-method token is configured, the calling or connected name is carried in a Display IE as a null terminated ASCII string.

## Calling Number Identification Service (CLIP/CLIR)

The Calling Number Identification Presentation (CLIP) and Calling Number Identification Restriction (CLIR) services provide for:

- Delivering a redirecting number to and from a PRI interface.
- Populating a PRI calling number with the original provisionable Signaling System 7 (SS7) calling party number (CPN), or the charge number (CN), if available.
- Transferring a connected number received in a connect message end-to-end on a PRI-to-PRI call.

## Redirecting Number Support

Redirecting Number IE support is available for NI2/4ESS and 5ESS switch types, and allows passing a redirecting number IE from one call leg to another. DMS Original Called Party Number support is also available. This allows the Cisco BTS 10200 Softswitch to receive an original called party number (OCPN) from an incoming PRI (configured as DMS-100), and to send an OCPN to a PRI (configured as DMS-100) interface.

# ISDN PRI PBX Variant Setup

The ISDN PRI implementation enhances the Cisco BTS 10200 Softswitch by allowing interconnection to small and medium businesses using legacy PBX PRI interfaces. The design provides for the transport of additional PRI Information Elements (IEs) and two messages. The IEs include high layer compatibility (HLC), low layer compatibility (LLC), redirecting number (RGN), original called number (OCN), and Connected Number (CN). Message support is also provided for NOTIFY messages, and supplementary service support is provided for the Calling Name feature.

The Cisco BTS 10200 Softswitch supports the following PRI variants:

- Nortel DMS-100
- Lucent-5ESS
- AT&T-4ESS
- NI2

**Note**

The proprietary-supp token must be set to 8 when provisioning NI2.

The following sections provide the provisioning steps for specific PBXs. The steps are executed by using the Cisco BTS 10200 Softswitch CLI. For more information about using the CLI, see the *Cisco BTS 10200 Softswitch Command Line Interface Guide*.

[Table 1-3](#) lists the switch vendors, protocol, the section, and the page of the configuration example.

**Table 1-3** Switch Vendors, Protocol and Configuration Examples

Switch Vendor	NI2	DMS-100	4ESS	5ESS
Lucent	<a href="#">Lucent Definity G3r with NI2, page 1-26</a>	<a href="#">Lucent Definity G3r with DMS-100, page 1-26</a>	Unknown	<a href="#">Lucent Definity G3r with 5ESS, page 1-26</a>
Nortel	<a href="#">Nortel Option 11 with NI2, page 1-27</a> <a href="#">Nortel Northstar with NI2, page 1-27</a>	<a href="#">Nortel Option 11 with DMS-100, page 1-27</a>	Unknown	Unknown
Intertel	<a href="#">Intertel 256 with NI2, page 1-25</a>	<a href="#">Intertel 256 with DMS-100, page 1-25</a>	<a href="#">Intertel 256 with 4ESS, page 1-25</a>	<a href="#">Intertel 256 with 5ESS, page 1-25</a>
Siemens	<a href="#">Siemens Hicom 300 with NI2, page 1-27 (New)</a>	<a href="#">Siemens Hicom 300 with DMS-100, page 1-27</a>	<a href="#">Siemens Hicom 300 with 4ESS, page 1-28</a>	<a href="#">Siemens Hicom 300 with 5ESS, page 1-28</a>
Toshiba	<a href="#">Toshiba Strada DK424 with NI2, page 1-28</a>	Unknown	Unknown	Unknown

Use the ISDN provisioning steps provided in the “Cisco BTS 10200 Provisioning” section on page 1-4 to provision the following PBXs, with the exception of Step 3a in the “Provisioning” section on page 1-5. Replace Step 3a, adding an ISDN D-Channel profile, using the examples shown below for each PBX. You may need to modify the example given to suit your specific equipment setup.

**Note**

Cisco recommends configuring a DN1 on the main subscriber of each ISDN trunk for the CNAM feature. Otherwise, number delivery may not work as expected.

## Intertel 256 with NI2

To provision an Intertel 256 with NI2 (Intertel NI2 PBX), replace Step 3a with the following:

```
add isdn-dchan-profile id=intertel-cnamraw;type=swv-us-ni2-pri;isdn-service-supp=n;
isdn-restart-pri-supp=n;isdn-query-supp=y; isdn-restart-chan-supp=n;
isdn-restart-interface-supp=y; nfas-supp=n;bchan-neg-supp=y;
cname-encode-method=raw-disp; disp-ie-supp=y; disp-ie-codeset=0; isdn-farend-init=y;
send-group-dn=n;
```

## Intertel 256 with DMS-100

To provision an Intertel 256 with DMS-100 (Intertel DMS-100 PBX), replace Step 3a with the following:

```
add isdn-dchan-profile id=intertel-dms100;type=swv-dms-pri;interface-type=network;
isdn-service-supp=y; isdn-restart-chan-supp=y; isdn-restart-interface-supp=y;
isdn-farend-init=n; send-group-dn=n;t-301=300;t-302=10;t-303=4;t-305=30; t-308=4;
t-309=90;t-310=10;t-316=30;t-322=4; t-323=30; isdn-query-supp=y;
isdn-restart-pri-supp=y;nfas-supp=n;t-321=20;bchan-neg-supp=y;iw-spec=t1-609;
disp-ie-supp=y;facil-ie-supp=n;cname-encode-method=protocol;
```

## Intertel 256 with 4ESS

To provision an Intertel 256 with 4ESS (Intertel 4ESS PBX) with calling name support in a raw display IE, replace Step 3a with the following:

```
add isdn-dchan-profile id=intertel-4ess;type=swv-4ess;isdn-service-supp=n;
isdn-restart-pri-supp=n;isdn-query-supp=y; isdn-restart-chan-supp=n;
isdn-restart-interface-supp=y; nfas-supp=n;bchan-neg-supp=y;cname-encode-method=raw-disp;
disp-ie-supp=y; disp-ie-codeset=0; isdn-farend-init=y;facil-ie-supp=n; facil-ie-codeset=0;
flip-chan-ext-bit=n;
```

## Intertel 256 with 5ESS

To provision an Intertel 256 with 5ESS (Intertel 5ESS PBX), replace Step 3a with the following:

```
add isdn-dchan-profile id=intertel-5ess; type=swv-5ess-pri; isdn-service-supp=n;
isdn-farend-init=n; isdn-restart-pri-supp=n;isdn-query-supp=y; nfas-supp=n;
isdn-restart-chan-supp=n; bchan-neg-supp=y;disp-ie-supp=y;
disp-ie-codeset=0; cname-encode-method=raw-disp
```

## Lucent Definity G3r with NI2

To provision a Lucent Definity G3r with NI2 (FAS NI2 Lucent PBX) without service messaging, replace Step 3a with the following:

```
add isdn-dchan-profile id=lucent-fas; type=swv-us-ni2-pri; isdn-service-supp=n;
isdn-farend-init=y; isdn-restart-pri-supp=n; isdn-query-supp=y; nfas-supp=n;
isdn-restart-chan-supp=n; isdn-restart-interface-supp=y; bchan-neg-supp=y;
```



### Note

This configuration does not support CNAME.

To provision an NI2 Lucent PBX with calling name support (per GR1367), and replacement of a calling party number with a charge number, replace Step 3a with the following 2 commands:

```
add isdn-dchan-profile id=lucent-ni2; type=swv-us-ni2-pri; isdn-service-supp=n;
isdn-farend-init=y; isdn-restart-pri-supp=n; isdn-query-supp=y;
nfas-supp=n; isdn-restart-chan-supp=n; isdn-restart-interface-supp=y; bchan-neg-supp=y;
cname-encode-method=protocol; facil-ie-supp=y; facil-ie-codeset=0;
```

```
add isdn-tg-profile id=lucent; inband-info=y; chrg-num-supp=y;
```

To provision an NI2 Lucent PBX with calling name support in a raw display IE, replace Step 3a with the following:

```
add isdn-dchan-profile id=lucent-cnammraw; type=swv-us-ni2-pri; isdn-service-supp=n;
isdn-restart-pri-supp=n; isdn-query-supp=y; isdn-restart-chan-supp=n;
isdn-restart-interface-supp=y; nfas-supp=n; bchan-neg-supp=y;
cname-encode-method=raw-disp; disp-ie-supp=y; disp-ie-codeset=0; isdn-farend-init=y;
```

## Lucent Definity G3r with DMS-100

To provision a Lucent Definity G3r with DMS-100 (Lucent DMS-100 PBX), replace Step 3a with the following:

```
add isdn-dchan-profile id=lucentdms100; type=swv-dms-pri; interface-type=network;
isdn-service-supp=n; isdn-restart-chan-supp=y; isdn-restart-interface-supp=y;
isdn-farend-init=n; t-301=300; t-302=10; t-303=4; t-305=30;
t-308=4; t-309=90; t-310=10; t-316=30; t-322=4; t-323=30; isdn-query-supp=y;
isdn-restart-pri-supp=y; nfas-supp=n; t-321=20; bchan-neg-supp=y; iw-spec=t1-609;
disp-ie-supp=y; facil-ie-supp=n;
```

## Lucent Definity G3r with 5ESS

To provision a Lucent Definity G3r with 5ESS (Lucent-5ESS PBX), replace Step 3a with the following:

```
add isdn-dchan-profile id=lucent-5ess; type=swv-5ess-pri; isdn-service-supp=n;
isdn-farend-init=n; isdn-restart-pri-supp=n; isdn-query-supp=y; nfas-supp=n;
isdn-restart-chan-supp=n; bchan-neg-supp=y; cname-encode-method=raw-disp;
disp-ie-supp=y; disp-ie-codeset=0;
```



### Note

With 5ESS, the calling, or connected, name is carried in a Display IE, thus  
cname-encode-method=raw-disp.

## Nortel Northstar with NI2

To provision a Nortel Northstar PBX with NI2, replace Step 3a with the following:

```
add isdn-dchan-profile id=nt-ni2; type=swv-us-ni2-pri;interface-type=network;
isdn-service-supp=n; isdn-restart-chan-supp=n; isdn-restart-interface-supp=y;
isdn-farend-init=n; isdn-query-supp=y; isdn-restart-pri-supp=n; nfas-supp=n;
bchan-neg-supp=y; iw-spec=t1-609;disp-ie-supp=y; facil-ie-supp=y;flip-chan-ext-bit=n;
facil-ie-codeset=0; disp-ie-codeset=0;proprietary-supp=0; cname-encode-method=protocol;
```

## Nortel Option 11 with NI2

To provision a Nortel NI2 PBX with calling name in a raw display IE support, replace Step 3a with the following:

```
add isdn-dchan-profile id=nt-ni2;type=swv-us-ni2-pri;isdn-service-supp=n;
isdn-farend-init=n;isdn-restart-pri-supp=n;isdn-query-supp=y;nfas-supp=n;
isdn-restart-chan-supp=n; isdn-restart-interface-supp=y;bchan-neg-supp=y;
cname-encode-method=protocol;disp-ie-supp=y; disp-ie-codeset=0;
```

## Nortel Option 11 with DMS-100

To provision a Nortel DMS-100 PBX with calling name support (per DMS-100 specifications) and replacement of calling party number with charge number, replace Step 3a with the following 2 commands:

```
add isdn-dchan-profile id=nt-dms100;type=swv-dms-pri;isdn-service-supp=n;
isdn-farend-init=n isdn-restart-pri-supp=n;isdn-query-supp=y; nfas-supp=n;
isdn-restart-chan-supp=n;isdn-restart-interface-supp=y;bchan-neg-supp=y;
cname-encode-method=protocol;disp-ie-supp=y; disp-ie-codeset=0;
```

```
add isdn-tg-profile id=lucent; inband-info=y; chrg-num-supp=y;
```

## Siemens Hicom 300 with NI2

To provision a Siemens Hicom 300 with NI2 (Siemens NI1 PBX), replace Step 3a with the following:

```
add isdn-dchan-profile id=sieman-cnamraw;type=swv-us-ni2-pri;isdn-service-supp=n;
isdn-restart-pri-supp=n;isdn-query-supp=y; isdn-restart-chan-supp=n;
isdn-restart-interface-supp=y; nfas-supp=n;bchan-neg-supp=y;cname-encode-method=raw-disp;
disp-ie-supp=y; disp-ie-codeset= 0; isdn-farend-init=y;
```

## Siemens Hicom 300 with DMS-100

To provision a Siemens Hicom 300 with DMS-100 (Siemens NI1 PBX), replace Step 3a with the following:

```
add isdn-dchan-profile id=sieman-dms100;type=swv-dms-pri;interface-type=network;
isdn-service-supp=y; isdn-restart-chan-supp=y;isdn-restart-interface-supp=y;
isdn-farend-init=n; t-301=300;t-302=10; t-303=4;t-305=30;
t-308=4;t-309=90;t-310=10;t-316=30;t-322=4; t-323=30; isdn-query-supp=y;
isdn-restart-pri-supp=y;nfas-supp=n;t-321=20;bchan-neg-supp=y;iw-spec=t1-609;
disp-ie-supp=y;facil-ie-supp=n;cname-encode-method=protocol;
```

## Siemens Hicom 300 with 4ESS

To provision a Siemens 4ESS PBX with calling name support in a raw display IE, replace Step 3a with the following:

```
add isdn-dchan-profile id=siemens-4ess;type=swv-4ess;isdn-service-supp=n;
isdn-restart-pri-supp=n;isdn-query-supp=y; isdn-restart-chan-supp=n;
isdn-restart-interface-supp=y; nfas-supp=n;bchan-neg-supp=y;cname-encode-method=raw-disp;
disp-ie-supp=y; disp-ie-codeset= 0; isdn-farend-init=y; facil-ie-supp=n;
facil-ie-codeset= 0; flip-chan-ext-bit=n;
```

## Siemens Hicom 300 with 5ESS

To provision a Siemens Hicom 300 with 5ESS (Siemens NI1 PBX), replace Step 3a with the following:

```
add isdn-dchan-profile id=sieman-5ess; type=swv-5ess-pri; isdn-service-supp=y;
isdn-farend-init=n; isdn-restart-pri-supp=n;isdn-query-supp=y; nfas-supp=n;
isdn-restart-chan-supp=n; bchan-neg-supp=y;disp-ie-supp=y;
disp-ie-codeset=0;cname-encode-method=raw-disp
```

## Toshiba Strada DK424 with NI2

To provision a Toshiba Strada DK424 with NI2 (Toshiba NI1 PBX), replace Step 3a with the following:

```
add isdn-dchan-profile id=toshiba-ni2; type=swv-us-ni2-pri; interface-type=network;
isdn-service-supp=n; isdn-restart-chan-supp=y;
isdn-restart-interface-supp=y;isdn-farend-init=n; t-301=300;t-302=10;
t-303=4;t-305=30;t-308=4; t-309=90;t-310=10;t-316=30;t-322=4;t-323=30;
isdn-query-supp=y; isdn-restart-pri-supp=y;nfas-supp=n;t-321=20;
bchan-neg-supp=y; iw-spec=t1-609;disp-ie-supp=y;
cname-encode-method=raw-disp; facil-ie-supp=n; facil-ie-codeset=0;disp-ie-codeset=6;
```



### Note

Special steps may be required in order to modify the digits sent to the PBX. For example, if your Toshiba NI2 PBX needs only 3 digits of the dialed number, modify the following tokens:

```
add digman-profile id=toshiba;
add digman id=toshiba;rule=1; match-string=^9722591; replace-string=none;
change destination dest-id=isdn-131; dnis-digman-id=toshiba;
add dial-plan id=dp1; digit-string=9722591; dest-id=isdn-131; noa=unknown;
```



## CHAPTER 2

# Multiple Trunk Groups on a Single ISDN D-Channel

Revised: January 31, 2008, OL-12436-02

The Cisco BTS 10200 Softswitch supports ISDN 23B+D on a single T1 port with the ability to define explicit routing from a DN to a group of CICs or DS0s. To support using a different DN to route to an ISDN 23B+D, multiple trunk groups must be provisioned on a single D-channel. The trunk group is a logical entity used to group a range of B-channels or a single B-channel in a D-channel (ISDN T1). Specific DNs can be associated to the trunk groups for explicit routing of a DN to a specific range of B-channels in the ISDN D-channel (23B+D).

## Provisioning

This section describes provisioning multiple trunk groups on a single ISDN D-Channel.

**Step 1** Add one ISDN D-channel id.

```
add isdn-dchan id=40089; dchan-type=primary; dchan-format=slot-port;
dchan-slot=2;dchan-port=21;sctp_assoc_id=c5400_102;
backhaul-type=IUA; isdn_dchan-profile-id=NI2; dchan-intf=0;
```

**Step 2** Provision multiple trunk groups to the same ISDN D-channel id (40089). In this example, 6 trunk groups: 9950, 9951, 9952, 9953, 9954, 9955 are provisioned.

```
add trunk-grp id=9950; call-agent-id=CA146; tg-type=ISDN; tg-profile-id=tb78-isdn-dchan1;
pop-id=tb78; GLARE=ALL; mgcp-pkg-type=T; dial-plan-id=tb78; isdn-dchan-id=40089;
```

```
add trunk-grp id=9951; call-agent-id=CA146; tg-type=ISDN; tg-profile-id=tb78-isdn-dchan1;
pop-id=tb78; GLARE=ALL; mgcp-pkg-type=T; dial-plan-id=tb78; isdn-dchan-id=40089;
```

```
add trunk-grp id=9952; call-agent-id=CA146; tg-type=ISDN; tg-profile-id=tb78-isdn-dchan1;
pop-id=tb78; GLARE=ALL; mgcp-pkg-type=T; dial-plan-id=tb78; isdn-dchan-id=40089;
```

```
add trunk-grp id=9953; call-agent-id=CA146; tg-type=ISDN; tg-profile-id=tb78-isdn-dchan1;
pop-id=tb78; GLARE=ALL; mgcp-pkg-type=T; dial-plan-id=tb78; isdn-dchan-id=40089;
```

```
add trunk-grp id=9954; call-agent-id=CA146; tg-type=ISDN; tg-profile-id=tb78-isdn-dchan1;
pop-id=tb78; GLARE=ALL; mgcp-pkg-type=T; dial-plan-id=tb78; isdn-dchan-id=40089;
```

```
add trunk-grp id=9955; call-agent-id=CA146; tg-type=ISDN; tg-profile-id=tb78-isdn-dchan1;
pop-id=tb78; GLARE=ALL; mgcp-pkg-type=T; dial-plan-id=tb78; isdn-dchan-id=40089;
```

**Step 3** Provision one T1 endpoint to the 23 B-channels.

```
add termination prefix=S2/DS1-21/; port-start=1; port-end=23; type=trunk;
mgw-id=mgw_5400_isdn;
```

**Step 4** Provision group of B-channels to a specific trunk-group

```
add trunk cic-start=1; cic-end=7; tgn-id=9950; mgw-id=mgw_5400_isdn;
termination-prefix=S2/DS1-21/; termination-port-start=1; termination-port-end=7; INTF=0;

add trunk cic-start=8; cic-end=13; tgn-id=9951; mgw-id=mgw_5400_isdn;
termination-prefix=S2/DS1-21/; termination-port-start=8; termination-port-end=13; INTF=0;

add trunk cic-start=14; cic-end=15; tgn-id=9952; mgw-id=mgw_5400_isdn;
termination-prefix=S2/DS1-21/; termination-port-start=14; termination-port-end=15; INTF=0;

add trunk cic-start=16; cic-end=17; tgn-id=9953; mgw-id=mgw_5400_isdn;
termination-prefix=S2/DS1-21/; termination-port-start=16; termination-port-end=17; INTF=0;

add trunk cic-start=18; cic-end=20; tgn-id=9954; mgw-id=mgw_5400_isdn;
termination-prefix=S2/DS1-21/; termination-port-start=18; termination-port-end=20; INTF=0;

add trunk cic-start=21; cic-end=23; tgn-id=9955; mgw-id=mgw_5400_isdn;
termination-prefix=S2/DS1-21/; termination-port-start=21; termination-port-end=23; INTF=0;
```

**Step 5** Provision a dial plan for each of the 6 destination trunk groups.

a. Add the destination ids.

```
add destination dest-id=9950; call-type=local; route-type=route; route-guide-id=9950;
add destination dest-id=9951; call-type=local; route-type=route; route-guide-id=9951;
add destination dest-id=9952; call-type=local; route-type=route; route-guide-id=9952;
add destination dest-id=9953; call-type=local; route-type=route; route-guide-id=9953;
add destination dest-id=9954; call-type=local; route-type=route; route-guide-id=9954;
add destination dest-id=9955; call-type=local; route-type=route; route-guide-id=9955;
```

b. Add the dial plan ids.

```
add dial-plan id=tb78; digit-string=469450; dest-id=9950;
add dial-plan id=tb78; digit-string=469451; dest-id=9951;
add dial-plan id=tb78; digit-string=469452; dest-id=9952;
add dial-plan id=tb78; digit-string=469453; dest-id=9953;
add dial-plan id=tb78; digit-string=469454; dest-id=9954;
add dial-plan id=tb78; digit-string=469455; dest-id=9955;
```

c. Add the route guide ids.

```
add route-guide id=9950; policy-type=ROUTE; policy-id=9950;
add route-guide id=9951; policy-type=ROUTE; policy-id=9951;
add route-guide id=9952; policy-type=ROUTE; policy-id=9952;
add route-guide id=9953; policy-type=ROUTE; policy-id=9953;
add route-guide id=9954; policy-type=ROUTE; policy-id=9954;
add route-guide id=9955; policy-type=ROUTE; policy-id=9955;
```

d. Add the route ids.

```
add route id=9950; tgn1-id=9950;
add route id=9951; tgn1-id=9951;
add route id=9952; tgn1-id=9952;
add route id=9953; tgn1-id=9953;
add route id=9954; tgn1-id=9954;
add route id=9955; tgn1-id=9955;
```

# Sample Line Test Configuration for Multiple Trunk Groups on a Single ISDN D-Channel

A single ISDN 23B+D can support multiple test lines to run different tests. Each B-channel in the ISDN 23B+D is connected to a different type of test and requires a different DN to route to the test destination.

Table 2-1 provides a sample ISDN 23B+D line test configuration supporting multiple trunk groups. Each trunk group in the D-channel is routed using a different DN (one T1 per slot or port).

**Table 2-1** Sample ISDN 23B+D Line Test Configuration

T1 Port	DS0 (B-channel)	Test Type	Phone Number	Agent Type	Trunk Group
Port #1	Channel #1	PESQ 2.1, VQES 3.0, DTMF 1.1, Speech and DTMF 1.0	XXX-XXX-XXXX	Initiator	9950
Port #1	Channel #2	PESQ 2.1, VQES 3.0, DTMF 1.1, Speech and DTMF 1.0			
Port #1	Channel #3	PESQ 2.1, VQES 3.0, DTMF 1.1, Speech and DTMF 1.0			
Port #1	Channel #4	PESQ 2.1, VQES 3.0, DTMF 1.1, Speech and DTMF 1.0			
Port #1	Channel #5	PESQ 2.1, VQES 3.0, DTMF 1.1, Speech and DTMF 1.0			
Port #1	Channel #6	PESQ 2.1, VQES 3.0, DTMF 1.1, Speech and DTMF 1.0			
Port #1	Channel #7	PESQ 2.1, VQES 3.0, DTMF 1.1, Speech and DTMF 1.0			
Port #1	Channel #8	PESQ 2.1, VQES 3.0, DTMF 1.1	YYY-YYY-YYYY	Responder	9951
Port #1	Channel #9	PESQ 2.1, VQES 3.0, DTMF 1.1			
Port #1	Channel #10	PESQ 2.1, VQES 3.0, DTMF 1.1			
Port #1	Channel #11	PESQ 2.1, VQES 3.0, DTMF 1.1			
Port #1	Channel #12	PESQ 2.1, VQES 3.0, DTMF 1.1			
Port #1	Channel #13	PESQ 2.1, VQES 3.0, DTMF 1.1			
Port #1	Channel #14	Fax Termination	ZZZ-ZZZ-ZZZZ	Initiator	9952
Port #1	Channel #15	Fax Termination			
Port #1	Channel #16	Fax Termination	VVV-VVV-VVVV	Responder	9953
Port #1	Channel #17	Fax Termination			
Port #1	Channel #18	Code 100, 102, 105	PPP-PPP-PPPP	Initiator	9954
Port #1	Channel #19	Code 100, 102, 105			
Port #1	Channel #20	Code 100, 102, 105			
Port #1	Channel #21	Code 105	NNN-NNN-NNNN	Responder	9955
Port #1	Channel #22	Code 105			

**Table 2-1** Sample ISDN 23B+D Line Test Configuration

<b>T1 Port</b>	<b>DS0 (B-channel)</b>	<b>Test Type</b>	<b>Phone Number</b>	<b>Agent Type</b>	<b>Trunk Group</b>
Port #1	Channel #23	Code 105			
Port #1	Channel #24	ISDN D-Channel	N/A	Special	N/A



## CHAPTER 3

# ISDN Backhaul Support Using IUA/SCTP

---

**Revised: January 31, 2008, OL-12436-02**

This chapter describes the support of ISDN backhaul using ISDN Q.921-User Adaptation (IUA) and the Stream Control Transmission Protocol (SCTP). This support applies to both the user and network interfaces of an ISDN PRI configuration for facility associated signaling (FAS) as defined in RFC 3057. At this time, only FAS is supported for IUA. Using the Reliable User Datagram Protocol (RUDP) for PRI backhauling is not impacted by IUA/SCTP support. An ISDN trunking gateway can be configured to use either RUDP or IUA, but not both at the same time.

## IUA/SCTP Protocols

IUA and SCTP are two protocols defined for the transportation of telephony signaling over a packet network. SCTP is a reliable transport protocol like RUDP. IUA is the adaptation layer that makes SCTP services available to Q.921 services users, such as Q.931 and NI2. There are several benefits to using IUA/SCTP in place of Session Manager (SM)/RUDP, including the following:

- the multi-streaming feature of SCTP allows each D-channel to use a different stream to prevent head-of-line blocking.
- the multi-homing feature of SCTP provides more efficient network redundancy compared to RUDP.
- SCTP allows a configurable maximum outstanding receive window in number of bytes to get data through the network faster. RUDP supports a fixed value of 32 datagrams.
- SCTP uses dynamic timers based on calculated round trip time; RUDP has fixed timers.
- SCTP provides a cookie mechanism for better security.

In a typical network topology, one SCTP association is established between the gateway and each Call Agent. Multiple SCTP streams are carried out within each association. One stream is always dedicated for management purposes, and separate SCTP streams are used for each D-channel. Two IP addresses for each side are designated to the same SCTP association for multi-homing.

The IUA manager (IUM) process provides an interface to the IUA and SCTP stacks and communicates with the gateways. The Cisco SCTP and IUA stacks are used for this feature.

# Provisioning an IUA Trunk Group

This section provides examples of the steps required to build and provision an IUA trunk group on the Cisco BTS 10200 Softswitch.

**Note**

These tasks include examples of CLI commands that illustrate how to provision the specific feature. Most of these tables have additional tokens that are not included in the example. For a complete list of all CLI tables and tokens, refer to the *Cisco BTS 10200 Softswitch Command Line Interface Reference Guide*.

**Step 1** Add a media gateway profile.

**Note**

Several tokens have values that can be overwritten after the Call Agent queries the media gateway for supported capabilities. If the media gateway returns a value different from the value originally provisioned, the returned value automatically replaces the originally provisioned value.

```
add mgw-profile id=5400-iuasctpmgwp;vendor=Cisco;refresh-digit-map=y;
```

**Step 2** Add a media gateway.

```
add mgw id=5400-iuasctp-mgw; tsap-addr=c5400-93; call-agent-id=CA146;
mgw-profile-id=5400-iuasctpmgwp; type=TGW; mgw-port=2427;
```

**Step 3** Add an SCTP Association profile. The remote port configured in the SCTP Association table must match the local port specified in the gateway side when the Application Server was configured.

```
add sctp-assoc-profile id=5400-sctp-asscp;
```

**Step 4** Add an SCTP Association. The ULP token must be set to IUA for IUA/SCTP backhauling. The remote port specified in the gateway to configure ASP must match the standard local port used in the Cisco BTS 10200 Softswitch (for example, 9900).

```
add sctp-assoc id=iuasctp-assc1;ulp=IUA;
mgw-id=5400-iuasctp-mgw;sctp-assoc-profile-id=5400-sctp-asscp;platform-id=CA146;
remote-port=9900;remote-tsap-addr1=c5400-93;
```

**Step 5** Add an ISDN D channel profile.

```
add isdn-dchan-profile id=iua-dchanp
```

**Step 6** Add the ISDN interface. The ISDN Interface table defines the number of T1s per primary rate interface (PRI).

```
add isdn-intf intf=0;isdn-dchan-id=iua-s70;
```

**Step 7** Add the ISDN D-channel. Backhaul type must be set to IUA for IUA/SCTP backhauling.

```
add isdn-dchan id=iua-s70; dchan-type=PRIMARY; dchan-format=slot-port; dchan-slot=7;
dchan-port=0; sctp-assoc-id=iuasctp-assc1; backhaul-type=IUA;
isdn-dchan-profile-id=iua-dchanp;
```

**Step 8** Add an ISDN trunk group profile.

```
add isdn-tg-profile id=iua-dchnl-tgp1;
```

**Step 9** Add a trunk group. Pop1 and tb16 have already been provisioned.

```
add trunk-grp id=54007001;call-agent-id=CA146;tg-type=ISDN;tg-profile-id=iua-dchnl-tgp1;
glare=ALL; mgcp-pkg-type=T; dial-plan-id=tb16; isdn-dchan-id=iua-s70;pop-id=pop1;
```

**Step 10** Add a termination.

```
add termination prefix=S7/DS1-0/;port-start=1;port-end=23;type=trunk;
mgw-id=5400-iuasctp-mgw;
```

**Step 11** Add a trunk.

```
add trunk cic-start=1; cic-end=23; tgn-id=54007001; mgw-id=5400-iuasctp-mgw;
termination-prefix=S7/DS1-0/; termination-port-start=1; termination-port-end=23; intf=0;
```



**Note**

To support multiple trunk groups in one D-channel configuration, the 23 B-channels or CICs in the trunk table can be split or logically grouped into different trunk groups. See [Chapter 2, “Multiple Trunk Groups on a Single ISDN D-Channel”](#) for more information.

**Step 12** Add a route. The Route table contains a list of up to ten trunk groups to route a call.

```
add route id=isdn-iua-te; tgn1-id=54007001;
```

**Step 13** Add a route guide.

```
add route-guide ID=isdn-iua-rg; policy-type=ROUTE; policy-id=isdn-iua-rte;
```

**Step 14** Add a destination.

```
add destination dest-id=isdn-iua; call-type=toll; route-type=ROUTE; route-id=isdn-iua-rte;
route-guide-id=isdn-iua-rg;
```

**Step 15** Add a dial plan.

```
add dial-plan id=tb16; digit-string=416483; dest-id=isdn-iua;
```

**Step 16** Control the media gateway, SCTP Association, ISDN D-Channel and the trunk group in service (in the order stated).

```
control mgw id=5400-iuasctp-mgw;target-state=INS;mode=forced;
control sctp-assoc id=iuasctp-assc1;target-state=INS;mode=forced;
control isdn-dchan id=iua-s70;dchan-type=PRIMARY; target-state=INS;
control trunk-grp id=54007001;target-state=INS;mode=forced;
```

**Step 17** Equip the trunk termination and control it in service.

```
equip trunk-termination tgn-id=54007001;cic=all;

control trunk-termination tgn-id=54007001; cic=all; target-state=INS; mode=forced;
```





## CHAPTER 4

# Maintaining and Troubleshooting the ISDN System

---

Revised: January 31, 2008, OL-12436-02

This chapter describes ISDN maintenance and troubleshooting commands and procedures for the Cisco BTS 10200 Softswitch. See also the *Cisco BTS 10200 Softswitch Troubleshooting Guide* for more details about causes and corrective actions related to events and alarms.

## Status and Control Commands

This section describes the status and control commands for ISDN.

Table Name: ISDN-DCHAN

Table Containment Area: EMS, Call Agent

---

### Command Types

Status and control

---

### Examples

```
Status isdn-dchan dchan-type=primary;
Status isdn-dchan dchan-type= backup;
Control isdn-dchan dchan-type=primary; mode=forced; target-state=oos;
Control isdn-dchan dchan-type=backup; mode=forced; target-state=oos;
Control isdn-dchan dchan-type=primary; mode=forced; target-state=ins;
Control isdn-dchan dchan-type=backup; mode=forced; target-state=ins;
```

**Usage Guidelines**

Table 4-1 describes the D-channel operational status to status output mappings.

**Table 4-1 D-Channel Operational Status to Status Output Mapping**

<b>D-Channel Operational Status</b>	<b>Status Output</b>
DCHAN_OOS	ISDN D-Channel is Out-Of-Service
DCHAN_INS	ISDN D-Channel is In-Service
DCHAN_RESTORE_SESSION_SET_REQ_NORMAL	ISDN D-Channel restore session set request normal
DCHAN_RESTORE_SESSION_SET_REQ_SWITCHOVER	ISDN D-Channel restore session set request switchover
DCHAN_RESTORE_SESSION_SET_FAIL_NORMAL	ISDN D-Channel restore session set fail normal
DCHAN_RESTORE_SESSION_SET_FAIL_SWITCHOVER	ISDN D-Channel restore session set fail switchover
DCHAN_RESTORE_SCTP_ASSOC_REQ_NORMAL	ISDN D-Channel restore SCTP association request normal
DCHAN_RESTORE_SCTP_ASSOC_REQ_SWITCHOVER	ISDN D-Channel restore SCTP association request switchover
DCHAN_RESTORE_SCTP_ASSOC_ESTB_NORMAL	ISDN D-Channel restore SCTP association establish normal
DCHAN_RESTORE_SCTP_ASSOC_ESTB_SWITCHOVER	ISDN D-Channel restore SCTP association establish switchover
DCHAN_RESTORE_IUA_ACTIVE_NORMAL	ISDN D-Channel restore IUA layer active normal
DCHAN_RESTORE_IUA_ACTIVE_SWITCHOVER	ISDN D-Channel restore IUA layer active switchover
DCHAN_RESTORE_ESTABLISH_REQ_NORMAL	ISDN D-Channel restore establish request normal
DCHAN_RESTORE_ESTABLISH_REQ_SWITCHOVER	ISDN D-Channel restore establish request switchover
DCHAN_RESTORE_ESTABLISH_FAIL_NORMAL	ISDN D-Channel restore establish fail normal
DCHAN_RESTORE_ESTABLISH_FAIL_SWITCHOVER	ISDN D-Channel restore establish fail switchover
DCHAN_DOWN_SESSION_SET_FAIL_SOFT_NORMAL	ISDN D-Channel down session set fail soft normal
DCHAN_DOWN_SESSION_SET_FAIL_HARD_NORMAL	ISDN D-Channel down session set fail hard normal
DCHAN_DOWN_SCTP_ASSOC_FAIL_SOFT_NORMAL	ISDN D-Channel down SCTP association fail soft normal
DCHAN_DOWN_SCTP_ASSOC_FAIL_HARD_NORMAL	ISDN D-Channel down SCTP association fail hard normal
DCHAN_DOWN_IUA_INACTIVE_SOFT_NORMAL	ISDN D-Channel down IUA layer inactive soft normal

**Table 4-1 D-Channel Operational Status to Status Output Mapping (continued)**

D-Channel Operational Status	Status Output
DCHAN_DOWN_IUA_INACTIVE_HARD_NORMAL	ISDN D-Channel down IUA layer inactive hard normal
DCHAN_DOWN_ESTABLISH_REQ_SOFT_NORMAL	ISDN D-Channel down establish request soft normal
DCHAN_DOWN_ESTABLISH_REQ_HARD_NORMAL	ISDN D-Channel down establish request hard normal
DCHAN_DOWN_ESTABLISH_FAIL_SOFT_NORMAL	ISDN D-Channel down establish fail soft normal
DCHAN_DOWN_ESTABLISH_FAIL_HARD_NORMAL	ISDN D-Channel down establish fail hard normal
DCHAN_REMOVE_RELEASE_REQ	ISDN D-Channel remove release request
DCHAN_REMOVE_SESSION_SET_REQ	ISDN D-Channel remove session set request
DCHAN_REMOVE_SCTP_ASSOC_REQ	ISDN D-Channel remove SCTP association request
ISDN_DCHAN_REMOVE_GRACEFUL	ISDN D-Channel remove gracefully

Table 4-2 describes the D-channel NFAS operational status to status output mappings.

**Table 4-2 D-Channel NFAS Operational Status to Status Output Mapping**

D-Channel NFAS Operational Status	Status Output
ISDN_DCHAN_STATE_MOOS	ISDN D-Channel is Manual Out-of-Service
ISDN_DCHAN_STATE_SESSION_DOWN	ISDN D-Channel is Backhaul Session Down
ISDN_DCHAN_STATE_SESSION_UP	ISDN D-Channel is Backhaul Session Up
ISDN_DCHAN_STATE_OOS	ISDN D-Channel is Out-of-Service
ISDN_DCHAN_STATE_ESTB_REQ	ISDN D-Channel sent Establish Request
ISDN_DCHAN_STATE_REL_REQ	ISDN D-Channel sent Release Request
ISDN_DCHAN_STATE_IS	ISDN D-Channel is In-Service
ISDN_DCHAN_STATE_MB	ISDN D-Channel is Maintenance Busy
ISDN_DCHAN_STATE_WAIT	ISDN D-Channel is in Wait for Service Ack
ISDN_DCHAN_STATE_STBY	ISDN D-Channel is Standby
ISDN_DCHAN_STATE_CREATE_SCTP_ASSOC	ISDN D-Channel create SCTP Assoc Request
ISDN_DCHAN_STATE_SCTP_ASSOC_ESTB	ISDN D-Channel SCTP Assoc Established
ISDN_DCHAN_STATE_DELETE_SCTP_ASSOC	ISDN D-Channel delete SCTP Assoc Request

**Syntax Description**

See the *Cisco BTS 10200 Softswitch Command Line Interface Guide for Call Processing*, Chapter 6, ISDN D-Channel section for token information.

# How to Troubleshoot When the ISDN D-Channel Fails to Restore

This section shows how to troubleshoot if the ISDN D-channel fails to restore. Determine if the D-channel failed to restore by entering the following command:

```
status isdn-dchan id=nnn;dchan-type=<primary | backup>;
```

- If the response shows that the D-channel is out-of-service for the administrative state, then enter the control command.

```
status isdn-dchan id=100;dchan-type=primary
```

```
REASON -> ADM executed successfully
RESULT -> ADM configure result in success
ISDN DCHAN ID -> 100
DCHAN TYPE -> PRIMARY
ADMIN STATE -> ADMIN_OOS
OPER STATE -> ISDN D-Channel is Out-Of-Service
```

```
Reply : Success: at 2007-01-03 14:56:18 by btsadmin
```

```
control isdn-dchan id=nnn;dchan-type=<primary | backup>;target-state=ins
```

- If the response does not show that the D-channel is *in-service* (NFAS or D-channel backup may also show ISDN\_DCHAN\_STATE\_INS for the D-channel operational status), then:
  - If the response is *ISDN D-Channel out-of-service* go to Step 1.
  - If the response is *ISDN D-Channel restore session set fail normal or switchover* go to Step 2.
  - If the response is *ISDN D-Channel restore establish fail normal or switchover* go to Step 3.
  - If the response is *ISDN D-Channel is in Wait for Service Ack* or *ISDN D-Channel is Maintenance Busy* go to Step 4.
  - If the response is *ISDN D-Channel down session set fail hard normal* go to Step 5.
  - If the response is *ISDN D-Channel down establish fail hard normal* go to Step 6.
  - If the response is *ISDN D-Channel delete graceful* go to Step 7.

---

**Step 1** D-channel state for FAS: *ISDN D-Channel out-of-service*, or NFAS: *ISDN D-Channel is Manual Out-of-Service*.

This means the administrative state was set to in service, but the command to go to operational state was ignored due to bad provisioning.

### Things to Check:

Make sure that the correct entries exist in the ISDN D-Channel table.

**Step 2** D-channel states for FAS: *ISDN D-Channel restore establish fail normal or switchover*; or NFAS: *ISDN D-Channel is Backhaul Session Down*.

This means the Call Agent and the media gateway are not communicating. The backhaul session is not coming up. The problem has to do with the UDP port numbers, IP addresses or DNS names, or network connectivity. These values are all provisioned in the RUDP Backhaul Session table in the Call Agent. For Cisco IOS gateways, these values are part of the *session group groupn....*

**Things to Check:**

- a. Do the four entries in the RUDP Backhaul Session table of the Call Agent match the values in the gateway (for Cisco IOS gateways, these values are part of session group groupn...)?
- b. If the call-agent-tsap-addr, or the mgw-tsap-addr are DNS names, does **nslookup** on both Call Agents resolve the values to one unique IP address?
- c. Can the call-agent-tsap-addr in the four entries be pinged from the media gateway? Do the Call Agents actually have the IP addresses, or DNS names, specified?
- d. Can the mgw-tsap-addr be pinged from both Call Agents?
- e. Does the isdn-dchan-profile exist (show isdn-dchan-profile id=%)? Keep in mind that the profile id is case sensitive.
- f. Snoop can be used to see if the gateway and Call Agent are talking in order to establish the session. Snoop can be used to eliminate whether the problem is on the Call Agent or the media gateway side.
- g. The **show backhaul session all** command on the media gateway can be useful in debugging.
- h. Look at the trace.log on the Call Agent. Search for BSM\_create\_ss or bsm\_create\_ss. This shows the exact values used by the Call Agent.



---

**Note** Backhaul deletion is triggered by all D-channels of a backhaul-set being in the admin-oss state. Backhaul creation is triggered by controlling one of the trunk groups to INS. Determine the D-channel list using the **show isdn-dchan set-id** command.

---

- Step 3** D-channel states for FAS: *ISDN D-Channel restore establish fail normal or switchover* or NFAS: *ISDN D-Channel sent Establish Request*.

This means the specific ISDN D-channel could not be restored. This is likely related to ISDN layer1 or layer2 not being up, or related to DCHAN-SLOT and DCHAN-PORT in the ISDN D Channel table. The media gateway and Call Agent are communicating successfully (session came up).

**Things to Check:**

- a. On the media gateway, enter a **show isdn status command**. Is Layer 1 shown as ACTIVE? If not, there may be a cable problem, or the PBX is down.
- b. Does the **show isdn status** command return a *Network side configuration*? The PBX should be set up for the user side. The gateway should be setup for the network side.
- c. Was the media gateway reloaded (rebooted) after setting up parameters? There can be problems when this has not been done. This is usually reflected by having two TEI values for the T1.
- d. Are the DCHAN-SLOT and DCHAN-PORT provisioned correctly in the ISDN D Channel table?
- e. Does the T1 on the media gateway show an alarm (red or yellow lights)? These are more clues that there is an ISDN layer1 or layer2 problem.
- f. Is the controller T1, or interface Serialn:23, provisioned correctly on the gateway?
- g. Look at the trace.log on the Call Agent. Search for BSM\_dchan\_tbl\_insert or bsm\_dchan\_tbl\_insert. The slot-port value is the actual value retrieved from the database. For the AS5300, this value should be 0, 1, 2, or 3. This is a decimal value. The top 16 bits are the slot and the bottom 16 bits are the port.

- Step 4** D-channel states for NFAS: *ISDN D-Channel is in Wait for Service Ack* or *ISDN D-Channel is Maintenance Busy*.

This means the states at the far end are going to send a SERVICE\_ACK to the Cisco BTS 10200 Softswitch service message for PRI.

**Things to Check:**

Make sure the far end is sending a SERVICE\_ACK. There are some other D-channel states that happen after the ISDN backhaul is successfully established.

- Step 5** Trunk group states for FAS: *ISDN D-Channel down session set fail hard normal* or NFAS: *ISDN D-Channel is Backhaul Session Down*.

This is the same as *ISDN D-Channel restore session set fail normal* or *ISDN D-Channel is Backhaul Session Down*. However, in this case, the backhaul session was already successfully established, and then went out. This likely means that the Call Agent and media gateway have lost IP connectivity. Or, the media gateway has lost power. This can also happen if the provisioning was changed, particularly the session settings in the media gateway.

- Step 6** D-channel states for FAS: *ISDN D-Channel down establish fail hard normal* or NFAS: *ISDN D-Channel sent Establish Request*.

This is the same as *ISDN D-Channel restore establish fail normal* or *ISDN D-Channel sent Establish Request*. However, in this case, the D channel was already successfully established, and then went out.

**Things to Check:**

- a. Is, or was, the cable unplugged between the PBX and the gateway?
- b. Was the provisioning changed on the gateway?

**Step 7** Trunk group state for FAS: *ISDN D-Channel delete graceful*.

The following command indicates you are waiting for calls to finish before going to out-of-service. If the wait time is too long, you can control the trunk group with *mode=forced*.

```
control isdn-dchan id=xxxx; mode=graceful; target-state=oos;dchan-type=<primary | backup>
```

---

## Checking the Status of a Trunk Termination

Check the status of a trunk termination using the following command:

```
status trunk-termination tgn-id=<trunk group number>;cic=<cic number>;
```

```
Reply : Success:
```

```
TGN_ID -> 100
CIC -> 8
RESULT -> ADM configure result in success
REASON -> ADM executed successfully
TERM_ADMIN_STATE -> ADMIN_INS
TERM_OPER_STATE -> Term is available for new calls
TERM_REASON -> No fault reason available
TRUNK_STATIC_STATE -> ACTV
TRUNK_DYNAMIC_STATE -> IDLE
TRUNK_REASON -> NON_FAULTY
```

```
Reply : Success: at 2007-01-03 15:41:32 by btsadmin
Entry 1 of 1 returned.
```

The above status shows that the trunk is active, in idle mode, and ready for call use.

If the trunk static state is set to locally blocked, go to the [“Trunk Static State Is Set to Locally Blocked”](#) section.

If the trunk static state is set to TRNS, go to the [“Trunk Static State Is Set to TRNS”](#) section.

If the trunk static state is set to remotely blocked, go to the [“Trunk Static State Is Set to RBLK”](#) section.

If the trunk static state is set to TERM\_STATUS\_FAULTY, go to the [“Termination Status Is Faulty”](#) section.

If the trunk static state returns Cannot Make Call, go to the [“Cannot Make a Call”](#) section.

## Trunk Static State Is Set to Locally Blocked

Perform the following steps to check the *TRUNK REASON* field if the *TRUNK STATIC STATE* is set to locally blocked (LBLK) state.

- 
- Step 1** If the *TRUNK REASON* is set to MAINT-OOS, then a user has manually taken the trunks out of service. The user must manually put the trunks into the in-service mode.
- Use the **control** command on the specified trunk to put the trunk back into the in-service mode.
- Clear the MAINT-OOS. Trunks should be in active or idle mode and ready for use.
- Step 2** If the *TRUNK REASON* is set to SIGNALLING-FAULT, then the D channels are not in-service. Check the D-channels ADMIN and OPER states.
- If the D-channel ADMIN state is ADMIN\_OOS, use the **control** command to put the D-channel into in-service mode.
  - If the D-channel ADMIN state is ADMIN\_INS, verify that the D-channel OPER-STATE is IN-SERVICE (see the [How to Troubleshoot When the ISDN D-Channel Fails to Restore](#) section in case of any issues).
  - Clear any SIGNALLING-FAULT states. Trunks must be in active or idle mode and ready for use.
- Step 3** If *TRUNK REASON* is set to TERM\_FAULT, then the terminations are in FAULTY states. Verify the IP connectivity from the CA to the gateway.
- a. Clear any termination faults at the gateway by turning off, then turning on, MGCP (use the mgcp, no mgcp procedure on the media gateway).
  - b. Clear any TERM\_FAULT on the Cisco BTS 10200 Softswitch. Trunks must be in active or idle mode and ready for use.
- 

## Trunk Static State Is Set to TRNS

Perform the following steps when trunk static state is set to TRNS.



### Note

If trunk static state is set to TRNS, then the PBX has not responded with a SERVICE\_ACK or RESTART\_ACK for the service or restart message set by the Call Agent.

---

- Step 1** Verify that the initialization procedure, as depicted by the associated isdn-dchan-profile, and as used by PBX, is synchronized.
- Step 2** Verify that the isdn-service-supp token is set to N if PBX does not support service messages.
-

## Trunk Static State Is Set to RBLK

Perform the following steps if trunk static state is set to RBLK.

**Note**

If the trunk static state is set to RBLK, and isdn-dchan-profile has isdn-farend-init=Y then the PBX must start the initialization procedure, or the PBX specifically sends a service message with SERVICE-OOS mode to the Cisco BTS 10200 Softswitch to put the trunks into the remote out-of-state mode.

- 
- Step 1** Verify that the initialization procedure (ISDN-FAREND-INIT token), as depicted by associated isdn-dchan-profile in the Cisco BTS 10200 Softswitch, and as used by the PBX, is in sync.
- Step 2** Using the CLI command “control trunk-termination” to reset the RBLK state, perform a control trunk-termination to OOS, then control trunk-termination to INS—in case there is an error on the PBX side. Also, set the isdn-service-supp token in the ISDN D-channel group profile per the procedures supported by the PBX.
- 

## Termination Status Is Faulty

The *TERM\_STATUS\_FAULTY* message indicates an MGCP problem.

**Things to Check:**

- Is the MGW profile set up for the trunk?
- Is the MGW in the in-service operational state?

Perform the “no mgcp, mgcp” commands on the gateway if an MGCP problem is indicated.

## Cannot Make a Call

If you have a problem making a call, perform the following Things to Check, and then go to the [“Checking MGW Provisioning” section on page 4-11](#)

**Things to Check:**

When terminations are added, they have strings like S0/DS1-2/1. The S# refers to the slot number. The DS1-# refers to the port number. The /# at the end refers to the specific B channel (1–23). The slot and port numbers must match the dchan values (dchan-slot, dchan-port) for the related D-channel id (dchan-id), assuming that the DS0 is on a T1 that contains a D channel.

**Things to Check:**

- Are all Cisco BTS 10200 Softswitch ethernet cables plugged in and intact?
- Are all gateway ethernet cables plugged in and intact?

## IUA Traces

The existing Cisco BTS 10200 Softswitch trace capability is used to troubleshoot IUA and SCTP. Use the `get-trace` and `set-trace` CLI commands to enable and disable various trace details of the IUA/SCTP protocol at run time. Set the IUM process trace levels to INFO5 to enable IUA/SCTP traces.

The Call Agent table has an additional field, `IUA-DEBUG-LEVEL`, to enable and disable various trace details of the IUA stack using the `get-trace` and `set-trace` commands. The `IUA-DEBUG-LEVEL` can be set to any of the following:

- `ERROR` (Default)— Only error traces
- `STATE`— State transitions and errors.
- `PACKET`— IUA packets sent or received and errors
- `ALL`— SCTP signals received from SCTP stack, state transitions, IUA packets sent or received and errors.

The following example CLI command enables specific trace details:

```
set-trace call-agent id=CA146; trace-sctp-api=y; trace-sctp-txrxchunks=y;
trace-sctp-state=y; trace-sctp-signal=y; trace-sctp-multihome=y; trace-sctp-congestion=y;
trace-sctp-init=y;
```

The following example displays the output from the `get-trace` command:

```
get-trace call-agent id=CA146
```

```
CA ID -> CA146
RESULT -> ADM configure result in success
REASON -> ADM executed successfully
TRACE SCTP API -> Y
TRACE SCTP TXRXCHUNKS -> Y
TRACE SCTP STATE -> Y
TRACE SCTP SIGNAL -> Y
TRACE SCTP MULTIHOME -> Y
TRACE SCTP CONGESTION -> Y
TRACE SCTP INIT -> Y
IUA DEBUG LEVEL -> ERROR
```

```
Reply : Success: at 2006-04-10 13:11:59 by btsadmin
```

# Checking MGW Provisioning

This section describes how to check provisioning on IOS and IUA/SCTP gateways.

## IOS Gateway

The following example shows how a Cisco IOS gateway is provisioned for ISDN backhauling using RUDP.



**Note** The typical problem areas are in **bold** type. Look at the problem area after the Call Agent is provisioned.

```
Current configuration:
!
=====
version 12.2
no service pad
service timestamps debug datetime msec
service timestamps log datetime localtime
no service password-encryption
!
hostname c2421.200
!
enable password xxxxxxxx
!
clock timezone CDT -6
network-clock base-rate 56k
network-clock-select 3 T1 0
network-clock-select 1 T1 1
network-clock-select 2 system (SCB)
ip subnet-zero
!
!
ip domain-name ipclab.cisco.com
ip name-server 10.89.224.1
!
ip audit notify log
ip audit po max-events 100
backhaul-session-manager
  set isdn1 client ft
  group group1 set isdn1
  group group2 set isdn1
  session group group1 10.89.225.223 9000 10.89.227.200 9000 1
  session group group1 10.89.226.223 9001 10.89.227.200 9001 2
  session group group2 10.89.225.224 9000 10.89.227.200 9000 1
  session group group2 10.89.226.224 9001 10.89.227.200 9001 2
isdn switch-type primary-ni
isdn voice-call-failure 0
!
!
!
!
!
!
no voice confirmation-tone
voice-card 0
!
```

```

controller T1 0
  framing esf
  linecode b8zs
  channel-group 0 timeslots 1-24 speed 64
!
controller T1 1
  framing esf
  linecode b8zs
  pri-group timeslots 1-24 service mgcp
!
!
!
!
interface Ethernet0
  ip address 10.89.227.200 255.255.255.0
  no cdp enable
!
interface Serial0
  no ip address
  shutdown
!
interface Serial0:0
  no ip address
  ip nat outside
  encapsulation ppp
  shutdown
  no cdp enable
!
interface Serial1:23
  bandwidth 64000
  no ip address
  no logging event link-status
  isdn switch-type primary-ni
  isdn protocol-emulate network
  isdn incoming-voice voice
  isdn bind-13 backhaul isdn1
  no cdp enable
!
ip classless
ip route 0.0.0.0 0.0.0.0 10.89.227.254
no ip http server
ip pim bidir-enable
!
!
access-list 1 permit 10.0.24.0 0.0.0.255
call rsvp-sync
!
voice-port 1:23
!
mgcp
mgcp call-agent mgcp-SYS01CA.ipclab.cisco.com service-type mgcp version 1.0
mgcp dtmf-relay voip codec all mode nte-gw
mgcp package-capability rtp-package
mgcp default-package dt-package
no mgcp timer receive-rtcp
!
mgcp profile default
  timeout tsmx 100
  max2 retries 3
!
dial-peer cor custom
!
!
!
!

```

```

dial-peer voice 1 pots
  application mgcpapp
  port 1:23
!
!
line con 0
line aux 0
line 2 3
line vty 0 4
  password xxxxxxxx
  login
!
ntp server 10.89.227.254
end

```

## IUA/SCTP Gateway

The following example shows how a gateway is provisioned for IUA/SCTP.



**Note** The typical problem areas are in **bold type**. Look at the problem area after the Call Agent is provisioned.

```

Current configuration:
Current configuration : 3734 bytes
!
! No configuration change since last restart
!
version 12.2
service timestamps debug datetime msec
service timestamps log datetime localtime
no service password-encryption
!
hostname c5400-102
!
boot system flash:c5400-is-mz.sc70930
no boot startup-test
logging queue-limit 100
logging buffered 99999 debugging
enable password callagent
!
!
!
resource-pool disable
clock timezone cdt -5
spe default-firmware spe-firmware-1
aaa new-model
!
!
aaa authentication login default group tacacs+ enable
aaa authorization config-commands
aaa authorization exec default group tacacs+ none
aaa authorization commands 1 default group tacacs+ none
aaa authorization commands 15 default group tacacs+ none
aaa accounting exec default start-stop group tacacs+
aaa accounting commands 1 default start-stop group tacacs+
aaa accounting commands 15 default start-stop group tacacs+
aaa session-id common
ip subnet-zero

```

```

ip cef
ip domain name ipclab.cisco.com
ip name-server 10.89.224.1
ip name-server 10.89.224.9
!
isdn switch-type primary-ni
isdn voice-call-failure 0
isdn debug 0000043D
!
!
!
!
!
!
!
no voice hpi capture buffer
no voice hpi capture destination
!
!
!
mta receive maximum-recipients 0
!
iua
  AS as-tb78 10.89.232.102 9900
  ASP asp-tb78 AS as-tb78 190.101.56.214 190.101.55.214 9900
  ASP asp-sec-tb78 AS as-tb78 190.101.56.212 190.101.55.212 9900
!
!
controller T1 6/0
  framing esf
  linecode b8zs
  pri-group timeslots 1-24 service mgcp
!
controller T1 6/1
  framing esf
  linecode b8zs
!
controller T1 6/2
  framing sf
  linecode ami
!
controller T1 6/3
  framing sf
  linecode ami
  pri-group timeslots 1-24 service mgcp
!
controller T1 6/4
  framing sf
  linecode ami
!
controller T1 6/5
  framing sf
  linecode ami
controller T1 6/6
  framing sf
  linecode ami
!
controller T1 6/7
  framing sf
  linecode ami
!

```

```
controller T1 7/0
  framing sf
  linecode ami
!
controller T1 7/1
  framing sf
  linecode ami
!
controller T1 7/2
  framing sf
  linecode ami
!
controller T1 7/3
  framing sf
  linecode ami
!
controller T1 7/4
  framing sf
  linecode ami
!
controller T1 7/5
  framing sf
  linecode ami
!
controller T1 7/6
  framing sf
  linecode ami
!
controller T1 7/7
  framing sf
  linecode ami
!
!
interface FastEthernet0/0
  ip address 10.89.232.102 255.255.255.0
  duplex auto
!
interface FastEthernet0/1
  no ip address
  shutdown
  duplex auto
  speed auto
!
interface Serial0/0
  no ip address
  shutdown
  clockrate 2000000
!
interface Serial6/0
  no ip address
  shutdown
!
interface Serial7/0
  no ip address
  shutdown
!
interface Serial0/1
  no ip address
  shutdown
  clockrate 2000000
!
```

```

interface Serial6/0:23
  no ip address
  isdn switch-type primary-ni
  isdn protocol-emulate network
  isdn bind-13 iua-backhaul as-tb78
  no cdp enable
!
interface Serial6/3:23
  no ip address
  isdn switch-type primary-ni
  no cdp enable
!
interface Group-Async0
  no ip address
  group-range 1/00 5/107
!
ip classless
ip route 0.0.0.0 0.0.0.0 10.89.232.254
ip http server
!
!
logging trap debugging
logging 10.89.227.251
!
tacacs-server host 10.89.232.104
tacacs-server timeout 15
tacacs-server directed-request
snmp-server community public RO
snmp-server community private RW
snmp-server system-shutdown
snmp-server enable traps tty
!
radius-server authorization permit missing Service-Type
call rsvp-sync
!
voice-port 6/0:23
!
voice-port 6/3:23
!
mgcp
mgcp call-agent mga-SYS78CA146.ipclab.cisco.com service-type mgcp version 1.0
!
mgcp profile default
!
dial-peer cor custom
!
!
!
!
!
line con 0
line aux 0
line vty 0 4
  exec-timeout 30 0
  password callagent
line 1/00 3/107
  no flush-at-activation
  modem InOut
line 5/00 5/107
  no flush-at-activation
  modem InOut
!

```

```
scheduler allocate 10000 400
ntp server 10.89.227.254
end
```

## Additional CLI Verification

Perform the following steps to provide additional CLI verification of a problem:

- Step 1** Use the control command to put the trunk group out of service (OOS) and back into service (INS):

Place OOS:

```
control tgn-id=17; target-state=oos; mode=graceful;
```

Place INS:

```
control tgn-id=17; target-state=ins; mode=forced;
```

- Step 2** If the B channel is not IDLE, use the control command to put each circuit OOS and back INS:

Place OOS:

```
control trunk-termination tgn-id=17; cic=1; target-state=oos; mode=forced;
```

Place INS:

```
control trunk-termination tgn-id=17; cic=1; target-state=ins; mode=forced;
```

- Step 3** Check the status of the trunk group:

```
status trunk-grp id=<TG ID number>; call-agent-id=<CA ID>;
```

If the trunk group status has still not changed to ADMIN\_INS—even though the commands in Steps 1 and 2 were successful—then it means that communication to the MGW has been lost. Notify your system administrator and have the problem corrected before continuing.

- Step 4** Check trunk termination and trunk status. The single command shown here queries both the trunk-termination status and trunk (channel) status:

```
status trunk-termination tgn-id=17; cic=all;
```

Reply : Request was successful.

```
REPLY=1status is ....
CONFIGURATION COMMAND EXECUTED TRUNK_GRP -17 -CIC -1
TERM ADMINstatus -ADMIN_INS
TERM OPERstatus -TERM_STATE_IDLE
CIC STATIC STATE -ACTV
CIC DYNAMIC STATE -IDLE

...
...

23status is ....
CONFIGURATION COMMAND EXECUTED TRUNK_GRP -17 -CIC -23
TERM ADMINstatus -ADMIN_INS
TERM OPERstatus -TERM_STATE_IDLE
CIC STATIC STATE -ACTV
CIC DYNAMIC STATE -IDLE
```

```
status trunk-termination tgn-id=17; cic=23
```

```
Reply : Request was successful.
```

```
REPLY=CONFIGURATION COMMAND EXECUTED ISDN_TRUNK_GROUP -17 -CIC -23
TERM ADMINstatus -ADMIN_INS
TERM OPERstatus -TERM_STATE_IDLE
CIC STATIC STATE -ACTV
CIC DYNAMIC STATE -IDLE
```

---

## Maintenance of a Call Agent Connected to an ISDN Trunk Group

During system operations, the operator can use the CLI *control* command to switch the Call Agent into one of three states:

- NORMAL
- FORCED-ACTIVE-STANDBY
- FORCED-STANDBY-ACTIVE

When the control command is entered on a Call Agent connected to an ISDN trunk group (D channel), the Call Agent switchover time is approximately 20 seconds. During all but the first 6 seconds of this switchover time, the ISDN D channel is temporarily down. However, the D channel comes back up, and the ISDN trunk group automatically returns to in-service (INS), when the switchover completes.



### Note

This switchover process does not have any impact on stable calls.

---

## ISDN D-Channel and Trunk Group CLI Command Troubleshooting

[Table 4-3](#) describes how the CLI commands to perform common ISDN D-channel and trunk group operations for RUDP and IUA are different in Release 5.0, Release 4.5 and earlier. Use this table to ensure that the correct command for the release was used.

Table 4-3 CLI Command Differences by Release

Command Description	Release 4.5 and Earlier RUDP	Release 5.0 RUDP	Release 5.0 IUA
Bring up a backhaul session	N/A Controlling the trunk group in service automatically creates the backhaul session if the backhaul session was not already created.	N/A Controlling the D-channel in service automatically brings up the backhaul session if the backhaul session was not already created.	<code>control sctp-assoc id=&lt;isdnl&gt;; mode=forced; target-state=ins;</code>
Bring up a D-channel	N/A Controlling a trunk group in service automatically brings up the D-channel if the D-channel is not already up.	<code>control isdn-dchan id=&lt;dchan1&gt;; dchan-type=primary; target-state=ins; mode=forced;</code>	<code>control isdn-dchan id=&lt;dchan1&gt;; dchan-type=primary; target-state=ins; mode=forced;</code>
Bring up a trunk group	<code>control trunk-grp id=&lt;100&gt;; target-state=ins; mode=forced;</code>	<code>control trunk-grp id=&lt;100&gt;; target-state=ins; mode=forced;</code>	<code>control trunk-grp id=&lt;100&gt;; target-state=ins; mode=forced;</code>
Bring down a trunk group	<code>control trunk-grp id=&lt;100&gt;; target-state=oos; mode=forced;</code> Controlling a trunk group out of service automatically brings down the D-channel. It also brings down the backhaul session if the trunk group was the last trunk group configured in the gateway.	<code>control trunk-grp id=&lt;100&gt;; target-state=oos; mode=forced;</code>	<code>control trunk-grp id=&lt;100&gt;; target-state=oos; mode=forced;</code>
D-channel switchover (NFAS)	<code>control isdn-dchan tgn-id=&lt;100&gt;;</code>	<code>control isdn-dchan id=&lt;dchan1&gt;; mode=forced; target-state=switchover;</code>	<code>control isdn-dchan id=&lt;dchan1&gt;; mode=forced; target-state=switchover;</code>
Bring down the primary D-channel (NFAS)	N/A	<code>control isdn-dchan id=&lt;dchan1&gt;; dchan-type=primary; mode=forced; target-state=oos;</code>  For NFAS, this command brings the backup D-channel to Active state if it is in Standby state. Otherwise, the backup D-channel is not impacted by this command.  Controlling the primary D-channel out of service automatically brings down the backhaul session if the D-channel was the last D-channel configured in the gateway.	<code>control isdn-dchan id=&lt;dchan1&gt;; dchan-type=primary; mode=forced; target-state=oos;</code>  For NFAS, this command brings the backup D-channel to Active state if it is in Standby state. Otherwise, the backup D-channel is not impacted by this command.

Table 4-3 CLI Command Differences by Release (continued)

Command Description	Release 4.5 and Earlier RUDP	Release 5.0 RUDP	Release 5.0 IUA
Bring down the backup D-channel (NFAS)	N/A	<pre>control isdn-dchan id=&lt;dchan1&gt;; dchan-type=backup; mode=forced; target-state=oos;</pre> <p>This command brings the primary D-channel to Active state if it is in Standby state. Otherwise, the primary D-channel is not impacted by this command.</p> <p>Controlling the backup D-channel out of service automatically brings down the backhaul session if the D-channel was the last D-channel configured in the gateway.</p>	<pre>control isdn-dchan id=&lt;dchan1&gt;; dchan-type=backup; mode=forced; target-state=oos;</pre> <p>This command brings the primary D-channel to Active state if it is in Standby state. Otherwise, primary D-channel is not impacted by this command.</p>
Bring down both the primary and backup D-channels (if NFAS is configured)	N/A	<pre>control isdn-dchan id=&lt;dchan1&gt;; mode=forced; target-state=oos;</pre> <p>Controlling D-channel out of service automatically brings down the backhaul session if the D-channel was the last D-channel configured in the gateway.</p>	<pre>control isdn-dchan id=&lt;dchan1&gt;; mode=forced; target-state=oos;</pre>
Bring down the D-channel (if FAS is configured)	N/A	<pre>control isdn-dchan id=&lt;dchan1&gt;; dchan-type=primary; mode=forced; target-state=oos;</pre> <p>Controlling D-channel out of service automatically brings down the backhaul session if the D-channel was the last D-channel configured in the gateway.</p>	<pre>control isdn-dchan id=&lt;dchan1&gt;; dchan-type=primary; mode=forced; target-state=oos;</pre>
Bring down backhaul session	N/A	N/A	<pre>control sctp-assoc id=&lt;isdnl&gt;; target-state=oos; mode=forced;</pre>