



Cisco BTS 10200 Softswitch SS7 SIGTRAN Solution Guide

Release 5.0
May 7, 2007

Americas Headquarters
Cisco Systems, Inc.
170 West Tasman Drive
San Jose, CA 95134-1706
USA
<http://www.cisco.com>
Tel: 408 526-4000
800 553-NETS (6387)
Fax: 408 527-0883

Customer Order Number: OL-12779-01

THE SPECIFICATIONS AND INFORMATION REGARDING THE PRODUCTS IN THIS MANUAL ARE SUBJECT TO CHANGE WITHOUT NOTICE. ALL STATEMENTS, INFORMATION, AND RECOMMENDATIONS IN THIS MANUAL ARE BELIEVED TO BE ACCURATE BUT ARE PRESENTED WITHOUT WARRANTY OF ANY KIND, EXPRESS OR IMPLIED. USERS MUST TAKE FULL RESPONSIBILITY FOR THEIR APPLICATION OF ANY PRODUCTS.

THE SOFTWARE LICENSE AND LIMITED WARRANTY FOR THE ACCOMPANYING PRODUCT ARE SET FORTH IN THE INFORMATION PACKET THAT SHIPPED WITH THE PRODUCT AND ARE INCORPORATED HEREIN BY THIS REFERENCE. IF YOU ARE UNABLE TO LOCATE THE SOFTWARE LICENSE OR LIMITED WARRANTY, CONTACT YOUR CISCO REPRESENTATIVE FOR A COPY.

The Cisco implementation of TCP header compression is an adaptation of a program developed by the University of California, Berkeley (UCB) as part of UCB's public domain version of the UNIX operating system. All rights reserved. Copyright © 1981, Regents of the University of California.

NOTWITHSTANDING ANY OTHER WARRANTY HEREIN, ALL DOCUMENT FILES AND SOFTWARE OF THESE SUPPLIERS ARE PROVIDED "AS IS" WITH ALL FAULTS. CISCO AND THE ABOVE-NAMED SUPPLIERS DISCLAIM ALL WARRANTIES, EXPRESSED OR IMPLIED, INCLUDING, WITHOUT LIMITATION, THOSE OF MERCHANTABILITY, FITNESS FOR A PARTICULAR PURPOSE AND NONINFRINGEMENT OR ARISING FROM A COURSE OF DEALING, USAGE, OR TRADE PRACTICE.

IN NO EVENT SHALL CISCO OR ITS SUPPLIERS BE LIABLE FOR ANY INDIRECT, SPECIAL, CONSEQUENTIAL, OR INCIDENTAL DAMAGES, INCLUDING, WITHOUT LIMITATION, LOST PROFITS OR LOSS OR DAMAGE TO DATA ARISING OUT OF THE USE OR INABILITY TO USE THIS MANUAL, EVEN IF CISCO OR ITS SUPPLIERS HAVE BEEN ADVISED OF THE POSSIBILITY OF SUCH DAMAGES.

CCVP, the Cisco Logo, and the Cisco Square Bridge logo are trademarks of Cisco Systems, Inc.; Changing the Way We Work, Live, Play, and Learn is a service mark of Cisco Systems, Inc.; and Access Registrar, Aironet, BPX, Catalyst, CCDA, CCDP, CCIE, CCIP, CCNA, CCNP, CCSP, Cisco, the Cisco Certified Internetwork Expert logo, Cisco IOS, Cisco Press, Cisco Systems, Cisco Systems Capital, the Cisco Systems logo, Cisco Unity, Enterprise/Solver, EtherChannel, EtherFast, EtherSwitch, Fast Step, Follow Me Browsing, FormShare, GigaDrive, GigaStack, HomeLink, Internet Quotient, IOS, iPhone, IP/TV, iQ Expertise, the iQ logo, iQ Net Readiness Scorecard, iQuick Study, LightStream, Linksys, MeetingPlace, MGX, Networking Academy, Network Registrar, Packet, PIX, ProConnect, RateMUX, ScriptShare, SlideCast, SMARTnet, StackWise, The Fastest Way to Increase Your Internet Quotient, and TransPath are registered trademarks of Cisco Systems, Inc. and/or its affiliates in the United States and certain other countries.

All other trademarks mentioned in this document or Website are the property of their respective owners. The use of the word partner does not imply a partnership relationship between Cisco and any other company. (0612R)

Cisco BTS 10200 Softswitch Provisioning Guide
Copyright © 2005 Cisco Systems, Inc. All rights reserved.

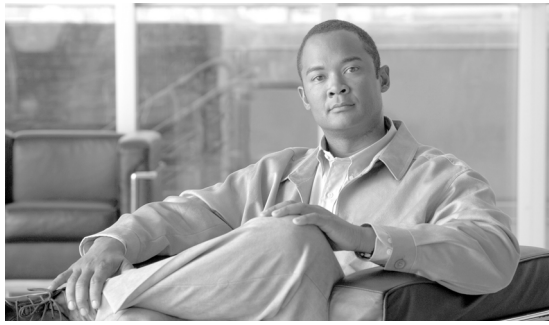

CONTENTS

Preface

Related Documents	v
Obtaining Documentation	vi
Cisco.com	vi
Documentation CD-ROM	vi
Ordering Documentation	vi
Documentation Feedback	vii
Obtaining Technical Assistance	vii
Cisco.com	vii
Technical Assistance Center	vii
Cisco TAC Website	viii
Cisco TAC Escalation Center	viii
Obtaining Additional Publications and Information	ix
Document Change History	ix

CHAPTER 1

SS7 Basic Configurations

Overview	1-1
Cisco BTS 10200 Softswitch Redundancy	1-2
ITP Redundancy	1-2
Hardware Redundancy	1-2
Platform Redundancy	1-2
SG Mated Pair	1-3
ITP-Group	1-4
BTS and ITP Base Configurations	1-5
Mated STP-Pair Configuration	1-5
Shared Point Code Configuration With A Links	1-6
Shared Point Code Configuration Connecting With E-Links	1-7
Shared Point Code Configuration Connecting With F-Links	1-8
ITP NSO Configuration	1-9
NSO Configuration with D Links	1-9
NSO Configuration with A and F Links	1-10

CHAPTER 2

Provisioning Basic SS7 Configurations

- ITP AS and ASP Configuration Example 2-1
- SCTP Provisioning 2-2
 - Provisioning SCTP Associations M3UA Layer 2-2
 - Provisioning SCTP Associations SUA Layer for LNP and 800 Services 2-2
 - Provisioning SCTP Association SUA Layer for ACAR and CNAM Services 2-2
 - Configuring SCTP Parameters 2-2
- Cisco ITP Configuration 2-3
 - Overlapping AS Configurations 2-4
 - GTT Configuration 2-5
- Cisco BTS 10200 Softswitch Configuration 2-6
- Mated STP-Pair Configuration Example 2-6
 - Cisco ITP Configuration 2-7
 - ITP1 Configuration 2-7
 - ITP2 Configuration 2-11
 - Cisco BTS10200 Provisioning for a Mated STP-Pair Configuration 2-14
- Shared Point Code Configuration Example 2-18
 - ITP Configuration 2-19
 - ITP1 Configuration 2-19
 - ITP2 Configuration 2-23
 - Cisco BTS 10200 Softswitch Provisioning for the Shared Point Code Configuration 2-26
- NSO Configuration Examples 2-31
 - D Link for ISUP with ASP Loading Sharing Configuration 2-31
 - D Link for TCAP with ASP Load Sharing Configuration 2-32

CHAPTER 3

Customer Profiles

- Multiple Cisco BTS 10200 Softswitch Nodes per ITP 3-1
 - Cisco ITP Configuration Example 3-2
 - Cisco BTS 10200 Softswitch Configuration Example 3-5
- Multiple OPCs on the Cisco BTS 10200 Softswitch 3-8
 - Configuration Requirements for Supporting 30 OPCs 3-9
 - Configuring the Subsystem_grp Table 3-9
 - Configuring the Subsystem Table 3-9
 - Configuring the SLHR Table 3-9
 - Configuring the SCCP_Route Table 3-9
 - Configuring the Routing_Key Table 3-9
 - Controlling the Subsystem Group In or Out of Service 3-9
- Alternate Base Profiles 3-10
 - ITP Configuration 3-10

Cisco BTS 10200 Softswitch Configuration Example	3-11
Multiple Cisco BTS 10200 Softswitch Nodes Sharing the Same OPC	3-16
Cisco ITP Configuration Example	3-17
Cisco BTS10200 Softswitch Provisioning Example	3-18
BTS1 Provisioning	3-18
BTS2 Provisioning	3-19
Geographically Separated Mated STP Pair with SG Priority Routing	3-20
Cisco ITP Configuration Example	3-21
Cisco BTS10200 Softswitch Provisioning Example	3-22
BTS1 Provisioning	3-22
BTS2 Provisioning	3-22

CHAPTER 4**SS7 SIGTRAN Troubleshooting**

Cisco ITP Troubleshooting Procedures	4-1
ITP System Messages	4-1
Logging On to the ITP	4-2
Viewing the ITP Configuration	4-2
ITP Status Commands	4-2
Controlling ITP Resources	4-2
Cisco BTS 10200 Softswitch Troubleshooting Procedures	4-3
Using Cisco BTS 10200 Softswitch CLI Commands	4-3
Viewing Cisco BTS 10200 Softswitch Logs	4-3
Troubleshooting Cisco BTS 10200 Softswitch Alarms	4-4
DPC Unavailable	4-5
DPC User Part Unavailable	4-5
DPC Congested	4-5
Signaling Gateway Group Is Out of Service	4-6
Signaling Gateway Failure	4-6
Signaling Gateway Process Is Out of Service	4-6
SCTP Association Failure	4-6
Debugging SCTP Problems for ISUP Applications	4-6
Debugging SCTP Problems for TCAP/SCCP Applications	4-10
SCTP Association Degraded	4-10
SCTP Association Configuration Error	4-10
M3UA Cannot Go Active	4-10
M3UA Cannot Go Standby	4-10
TCAP Binding Failure	4-11
Remote Subsystem Is Out Of Service	4-11
Debugging Network Problems for TCAP/SCCP Applications	4-11

- Verify the SCTP Association Status 4-11
- Verify the Configuration 4-12
- Verify the IP Routing 4-14
- Verify if the ASP is Used by Any AS 4-14
- Verify the ITP T1 Card Provisioning 4-14
- Verify the ITP MTP2 Serial Interface 4-14
- Verify the ITP-STP Linkset Status 4-15
- Verify the Cisco ITP Route 4-16
- Troubleshooting With the Query Command 4-16
 - Table Configuration Problems 4-17
 - Network Related Problems 4-17
 - No Translation for an Address of Such Nature 4-17
 - No Translation for this Specific Address 4-18
 - Subsystem Congestion 4-18
 - Subsystem Failure 4-18
 - Unequipped User 4-18
 - Network Failure 4-19
 - Network Congestion 4-19
 - Unqualified 4-19
 - Error In Message Transport 4-20
 - Destination Cannot Perform Reassembly 4-20
 - SCCP Failure 4-20
 - Hop Counter Violation 4-21
 - Segmentation Not Supported 4-21
 - Segmentation Failure 4-21
 - QVT Timeout 4-22
 - CLI Timeout 4-22

GLOSSARY

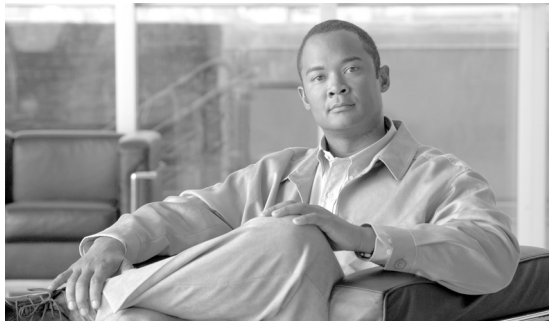

Preface

Revised: May 7, 2007, OL-12779-02

This document describes the SIGTRAN solution for the Cisco BTS 10200 Softswitch. It is intended for use by service provider management, system administration, and engineering personnel who are responsible for designing, installing, provisioning, and maintaining networks that use the Cisco BTS 10200 Softswitch.

Related Documents

This Release 5.0 Sigtran documentation should be used in conjunction with the following Cisco BTS 10200 Release 5.0 documents:

- *Cisco BTS 10200 Softswitch Release Notes for Release 4.4*
- *Cisco BTS 10200 Softswitch Physical and Network Site Surveys and Data Sheets*
- *Cisco BTS 10200 Softswitch Cabling Procedures*
- *Cisco BTS 10200 Softswitch System Description*
- *Cisco BTS 10200 Softswitch Application Installation Procedures*
- *Cisco BTS 10200 Softswitch Operations, Maintenance and Troubleshooting Manual*
- *Cisco BTS 10200 Softswitch Provisioning Guide*
- *Cisco BTS 10200 Softswitch Event Messages Guide*
- *Cisco BTS 10200 Softswitch Billing Interface Guide*
- *Cisco BTS 10200 Softswitch Command Line Interface Reference Guide*
- *Cisco BTS 10200 Softswitch CORBA Installation and Programmer's Guides*

The following Cisco ITP documents are also available:

- A high level overview of SCTP, M3UA, SCTP, and recommendations for choosing Cisco ITP platforms is available at http://www.cisco.com/en/US/products/sw/wirelssw/ps1862/products_white_paper09186a0080223b64.shtml
- ITP SNMP trap information can be found at: <http://sgm-sun2:1774/cgi-bin/level1/sgm1ist?mibs?>
- ITP system messages, for alarms and notifications, are in the appendix of the ITP Operations manual at: <http://www.cisco.com/univercd/cc/td/doc/product/wireless/moblwrls/itp>

**Note**

When debugging the ITP, the version of the ITP should be noted so the associated ITP manual can be consulted.

Obtaining Documentation

Cisco provides several ways to obtain documentation, technical assistance, and other technical resources. These sections explain how to obtain technical information from Cisco Systems.

Cisco.com

You can access the most current Cisco documentation on the World Wide Web at this URL:

<http://www.cisco.com/univercd/home/home.htm>

You can access the Cisco website at this URL:

<http://www.cisco.com>

International Cisco websites can be accessed from this URL:

http://www.cisco.com/public/countries_languages.shtml

Documentation CD-ROM

Cisco documentation and additional literature are available in a Cisco Documentation CD-ROM package, which may have shipped with your product. The Documentation CD-ROM is updated regularly and may be more current than printed documentation. The CD-ROM package is available as a single unit or through an annual or quarterly subscription.

Registered Cisco.com users can order a single Documentation CD-ROM (product number DOC-CONDOCCD=) through the Cisco Ordering tool:

http://www.cisco.com/en/US/partner/ordering/ordering_place_order_ordering_tool_launch.html

All users can order monthly or quarterly subscriptions through the online Subscription Store:

<http://www.cisco.com/go/subscription>

Ordering Documentation

You can find instructions for ordering documentation at this URL:

http://www.cisco.com/univercd/cc/td/doc/es_inpk/pdi.htm

You can order Cisco documentation in these ways:

- Registered Cisco.com users (Cisco direct customers) can order Cisco product documentation from the Networking Products Marketplace:

<http://www.cisco.com/en/US/partner/ordering/index.shtml>

- Nonregistered Cisco.com users can order documentation through a local account representative by calling Cisco Systems Corporate Headquarters (California, U.S.A.) at 408 526-7208 or, elsewhere in North America, by calling 800 553-NETS (6387).

Documentation Feedback

You can submit comments electronically on Cisco.com. On the Cisco Documentation home page, click **Feedback** at the top of the page.

You can e-mail your comments to bug-doc@cisco.com.

You can submit comments by using the response card (if present) behind the front cover of your document or by writing to the following address:

Cisco Systems
Attn: Customer Document Ordering
170 West Tasman Drive
San Jose, CA 95134-9883

We appreciate your comments.

Obtaining Technical Assistance

Cisco provides Cisco.com, which includes the Cisco Technical Assistance Center (TAC) website, as a starting point for all technical assistance. Customers and partners can obtain online documentation, troubleshooting tips, and sample configurations from the Cisco TAC website. Cisco.com registered users have complete access to the technical support resources on the Cisco TAC website, including TAC tools and utilities.

Cisco.com

Cisco.com offers a suite of interactive, networked services that let you access Cisco information, networking solutions, services, programs, and resources at any time, from anywhere in the world.

Cisco.com provides a broad range of features and services to help you with these tasks:

- Streamline business processes and improve productivity
- Resolve technical issues with online support
- Download and test software packages
- Order Cisco learning materials and merchandise
- Register for online skill assessment, training, and certification programs

To obtain customized information and service, you can self-register on Cisco.com at this URL:

<http://tools.cisco.com/RPF/register/register.do>

Technical Assistance Center

The Cisco TAC is available to all customers who need technical assistance with a Cisco product, technology, or solution. Two types of support are available: the Cisco TAC website and the Cisco TAC Escalation Center. The type of support that you choose depends on the priority of the problem and the conditions stated in service contracts, when applicable.

We categorize Cisco TAC inquiries according to urgency:

- Priority level 4 (P4)—You need information or assistance concerning Cisco product capabilities, product installation, or basic product configuration. There is little or no impact to your business operations.
- Priority level 3 (P3)—Operational performance of the network is impaired, but most business operations remain functional. You and Cisco are willing to commit resources during normal business hours to restore service to satisfactory levels.
- Priority level 2 (P2)—Operation of an existing network is severely degraded, or significant aspects of your business operations are negatively impacted by inadequate performance of Cisco products. You and Cisco will commit full-time resources during normal business hours to resolve the situation.
- Priority level 1 (P1)—An existing network is “down,” or there is a critical impact to your business operations. You and Cisco will commit all necessary resources around the clock to resolve the situation.

Cisco TAC Website

The Cisco TAC website provides online documents and tools to help troubleshoot and resolve technical issues with Cisco products and technologies. To access the Cisco TAC website, go to this URL:

<http://www.cisco.com/tac>

All customers, partners, and resellers who have a valid Cisco service contract have complete access to the technical support resources on the Cisco TAC website. Some services on the Cisco TAC website require a Cisco.com login ID and password. If you have a valid service contract but do not have a login ID or password, go to this URL to register:

<http://tools.cisco.com/RPF/register/register.do>

If you are a Cisco.com registered user, and you cannot resolve your technical issues by using the Cisco TAC website, you can open a case online at this URL:

<http://www.cisco.com/tac/caseopen>

If you have Internet access, we recommend that you open P3 and P4 cases online so that you can fully describe the situation and attach any necessary files.

Cisco TAC Escalation Center

The Cisco TAC Escalation Center addresses priority level 1 or priority level 2 issues. These classifications are assigned when severe network degradation significantly impacts business operations. When you contact the TAC Escalation Center with a P1 or P2 problem, a Cisco TAC engineer automatically opens a case.

To obtain a directory of toll-free Cisco TAC telephone numbers for your country, go to this URL:

<http://www.cisco.com/warp/public/687/Directory/DirTAC.shtml>

Before calling, please check with your network operations center to determine the Cisco support services to which your company is entitled: for example, SMARTnet, SMARTnet Onsite, or Network Supported Accounts (NSA). When you call the center, please have available your service agreement number and your product serial number.

Obtaining Additional Publications and Information

Information about Cisco products, technologies, and network solutions is available from various online and printed sources.

- The *Cisco Product Catalog* describes the networking products offered by Cisco Systems, as well as ordering and customer support services. Access the *Cisco Product Catalog* at this URL:
http://www.cisco.com/en/US/products/products_catalog_links_launch.html
- Cisco Press publishes a wide range of networking publications. Cisco suggests these titles for new and experienced users: *Internetworking Terms and Acronyms Dictionary*, *Internetworking Technology Handbook*, *Internetworking Troubleshooting Guide*, and the *Internetworking Design Guide*. For current Cisco Press titles and other information, go to Cisco Press online at this URL:
<http://www.ciscopress.com>
- *Packet* magazine is the Cisco quarterly publication that provides the latest networking trends, technology breakthroughs, and Cisco products and solutions to help industry professionals get the most from their networking investment. Included are networking deployment and troubleshooting tips, configuration examples, customer case studies, tutorials and training, certification information, and links to numerous in-depth online resources. You can access *Packet* magazine at this URL:
<http://www.cisco.com/go/packet>
- iQ Magazine is the Cisco bimonthly publication that delivers the latest information about Internet business strategies for executives. You can access iQ Magazine at this URL:
<http://www.cisco.com/go/iqmagazine>
- Internet Protocol Journal is a quarterly journal published by Cisco Systems for engineering professionals involved in designing, developing, and operating public and private internets and intranets. You can access the Internet Protocol Journal at this URL:
http://www.cisco.com/en/US/about/ac123/ac147/about_cisco_the_internet_protocol_journal.html
- Training—Cisco offers world-class networking training. Current offerings in network training are listed at this URL:
http://www.cisco.com/en/US/learning/le31/learning_recommended_training_list.html

Document Change History

Table 1 **Change History**

Document Number, Change Date	Change Summary
May 7, 2007	Chapter 3 Added support of 30 OPC section
March 15, 2007	Chapter 2 Updated per CSCsf17345. The DSCP is now configured in the ca-config tabl

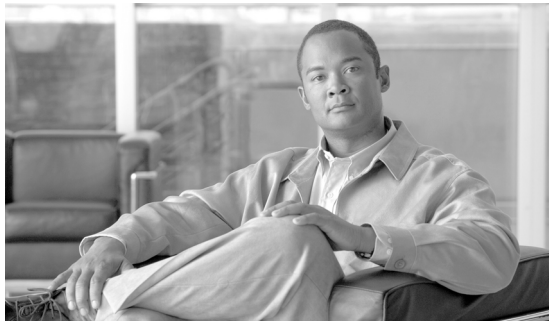

CHAPTER 1

SS7 Basic Configurations

Revised: May 7, 2007, OL-12779-02

Overview

Signaling System 7 (SS7) is an out of band signaling system used in the public switched telephone network (PSTN) to:

- Control call setup and tear down
- Transport circuit and non-circuit related information
- Support the Custom Local Calling Area Signaling Services (CLASS)

Signaling Transport (SIGTRAN) is a group of IETF standards that describe the SS7 signaling functionality of hardware nodes that interconnect IP based networks to SS7 networks.

The Cisco BTS 10200 Softswitch communicates with Signaling System 7 (SS7)-based PSTN switches and service control points (SCPs) by using a SIGTRAN-based signaling gateway (SG), the Cisco IP Transfer Point (ITP). The SIGTRAN interface carries all SS7 messages encapsulated in IP packets.

For a description of SS7 architecture, see the following URL:

http://www.cisco.com/univercd/cc/td/doc/product/tel_pswt/vco_prod/ss7_fund/index.htm.

The relationship of the BTS 10200 to the SS7 network is shown in [Figure 1-1](#).

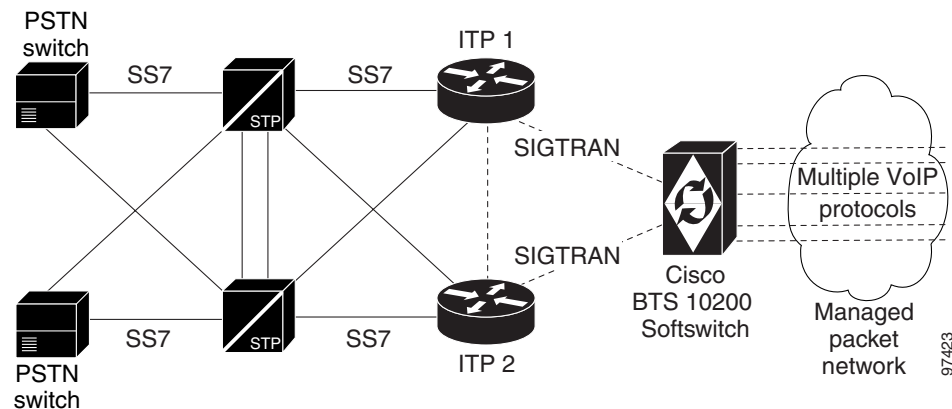
Figure 1-1 Cisco BTS 10200 Softswitch Interface to SS7 Network

Cisco BTS 10200 Softswitch Redundancy

Throughout this document, the term Cisco BTS 10200 Softswitch (BTS) refers to a Cisco BTS Active/Standby mated pair.

ITP Redundancy

All customer deployments of the SIGTRAN solution require ITP redundancy, and the following sections provide a brief overview of the ITP redundancy choices.

Hardware Redundancy

If the Cisco ITP 7507 platform is chosen, redundancy can be accomplished in a single node by inserting redundant cards within the chassis. To failover with minimum call disruption, the 7507 should be configured to operate in ITP Non Stop Operation (NSO).

This document does not recognize the 7507 platform as a fully redundant solution. However, it can be part of a fully redundant SG Mated Pair.

Platform Redundancy

ITP redundancy can also be accomplished by connecting two ITP nodes together. This can be done in one of two ways. The ITPs can be connected as SG Mated Pairs or as an ITP-Group.



Note

These two forms of redundancy cannot be combined.

The ITP NSO feature ensures that an ITP running on a Cisco 7500 router continues to operate in the with no outages in the event of a Route/Switch Processor (RSP) failure. The NSO feature supports two Signaling Gateway Platforms (SGPs) per Signaling Gateway (SG) in a Signaling Gateway Group (SG-grp) for mated Signal Transfer Points (STPs) and also supports the Sigtran M3UA and Single User Account (SUA) Application Server Process (ASP) load-share traffic modes.

This feature also enhances the IP layer implementation on the Versatile Interface Processor (VIP) cards for handling complex routing to remote destinations using either static routes or a routing protocol. With this additional capability, the ITP provides VIP redundancy in addition to platform and RSP redundancy.

For additional information, refer to [Chapter 1, “ITP NSO Configuration”](#).

An SG Mated Pair is usually used to connect to the service provider’s SS7 network via D-links. The ITP-Group is used when a customer wants a point code of the BTS to be shared with an SG point code. In this case, the connection to the service provider’s SS7 network is via A, E, or F-links.

SG Mated Pair

[Figure 1-2](#) illustrates an SG Mated Pair connection. Each identical ITP has its own point code and acts as an STP that connects to STPs in the SS7 network via D-links. Note that any ITP platform can be used for this form of redundancy.

Figure 1-2 ITP Mated Pair

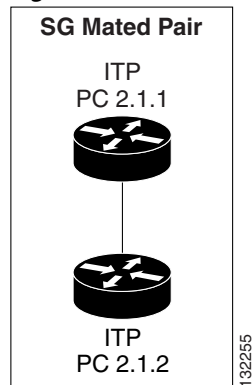

In this configuration, an ITP is treated as a SG with a single SGP. GTT can be supported by a capability point code, which is also known as an alias point code. A capability point code is shared by more than one system supporting the same GTT. Each signaling point with the same alias point code is capable of providing a predefined capability in the network.

From the BTS to the ITP, both load-sharing and redundancy standby mode are supported.

Benefits

- Fully hardware redundant and IP network redundant solution
- Each ITP acts as an STP and has full STP functionality
- GTT can be supported on the ITP through the use of a capability point code
- Geographical separation between ITPs is supported

Restrictions

- Each ITP requires a separate point code

ITP-Group

In an ITP-group configuration, illustrated in [Figure 1-3](#), each ITP acts as a physical signaling gateway process (SGP). Two of these physical signaling gateway processes can be connected together to form one logical signaling gateway. In this configuration, both ITPs share the same point code value, which is also shared by a Cisco BTS 10200 Softswitch. Note that this form of redundancy is not available for the 7507, since it has internal hardware redundancy. It is available for the 2651, the 7200VXR series, and the 7300 series ITPs.

Figure 1-3 ITP Group

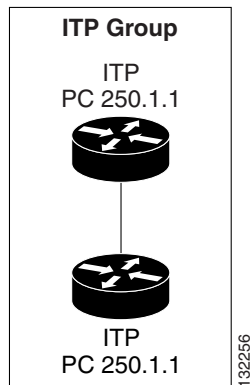

Benefits

- Two ITPs share the same point code, so fewer point codes are needed
- Identical ITPs for an SG
- A fully hardware redundant and IP network redundant solution

Restrictions

- GTT is not supported on the ITP.
- Only load sharing across the ITPs is supported. Prioritizing an ITP is not supported
- The two ITPs must be colocated.
- There is no gain in SS7 link capacity when two ITPs are combined in this manner. The SS7 link capacity of an ITP group is only equal to the capacity of a single ITP.



Note The 72XX series ITP can be used for greater link density.

BTS and ITP Base Configurations

There are two basic BTS/ITP base configurations that form the basis of all customer offered profiles and are described in the following sections.

- [Mated STP-Pair Configuration, page 1-5](#)
- [Shared Point Code Configuration With A Links, page 1-6](#)

Mated STP-Pair Configuration

A “D” (diagonal) link connects a secondary (local or regional STP pair to a primary (inter-network gateway) Signal Transfer Point (STP) pair in a quad-link configuration. Their function is to carry signaling messages beyond their initial point of entry to the signaling network towards their destination.

In a Mated STP-Pair configuration, each ITP acts as an STP and has its own unique point code. The ITPs connect to the SS7 network using D-links, as illustrated in [Figure 1-4](#). An SG mated pair is utilized for the Mated STP-Pair configuration.

Figure 1-4 Mated STP-Pair Configuration

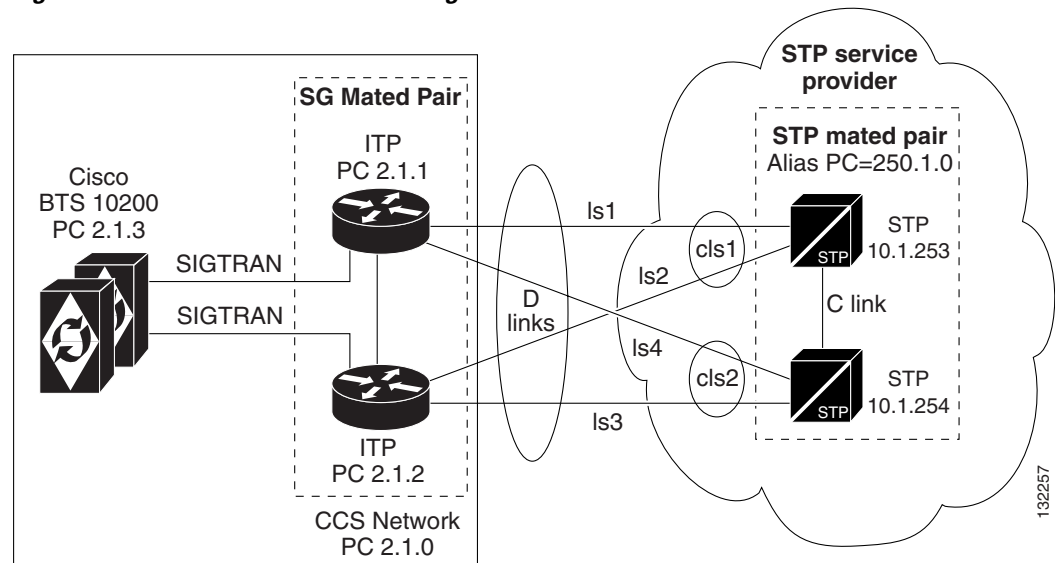

In an SG mated pair, redundancy is supported between the ITPs. The ITPs can still operate and provide some services if a BTS were to become unavailable. In this case, an ITP would send a TFP for the BTS point code and still act as a transfer point to other point codes in the SS7 network. Also, it can transfer messages to other BTS nodes in the case where there are multiple BTS nodes served by a single ITP pair.

The Mated STP-Pair configuration provides the following benefits:

- Multiple OPCs are supported on the BTS with just two ITPs.
- Geographical separation is allowed between the ITPs.
- The ITP supports GTT by using capability point codes for redundancy.
- High volume SS7 traffic can be supported by load sharing the traffic between the SG mated pair.
- Unlike the Shared Point Code solution, there is no need to purchase additional connections to the SS7 network when more OPCs are added to the BTS.

- The SS7 network is able to distinguish between the status of the BTS and that of the ITP.
- All ITP platforms can be used as part of the Mated STP-Pair solution.

The Mated STP-Pair configuration has the following restrictions:

- Each ITP needs its own point code. This allows for greater scalability when multiple OPCs are needed on the Cisco BTS 10200 Softswitch.
- Service providers charge more for Mated STP-Pair connections, when D-links are used, than when A-link connections are used, which is commonly part of the Shared Point Code solution.

Shared Point Code Configuration With A Links

“A” (access) links connect a signaling end point (an SCP or SSP) to an STP. Only messages originating from or destined to the signaling end point are transmitted on an A-link.

In this configuration, both ITPs and the BTS10200 are viewed as a single point code from the service provider's SS7 network. This is possible since the same point code value is shared by both of the ITPs and is provisioned as an OPC value on the BTS. The ITP Group, consisting of two ITPs, acts as the SS7 proxy for the BTS10200. The ITPs connect to the SS7 network using A-links, E-links, or F-links, as illustrated in [Figure 1-5](#).



Note

In the event that a BTS 10200 system becomes unavailable, the ITP will send a UPU to the SS7 network but cannot provide any other services.

Figure 1-5 Shared Point Code Configuration using an ITP Group (Distributed MTP)

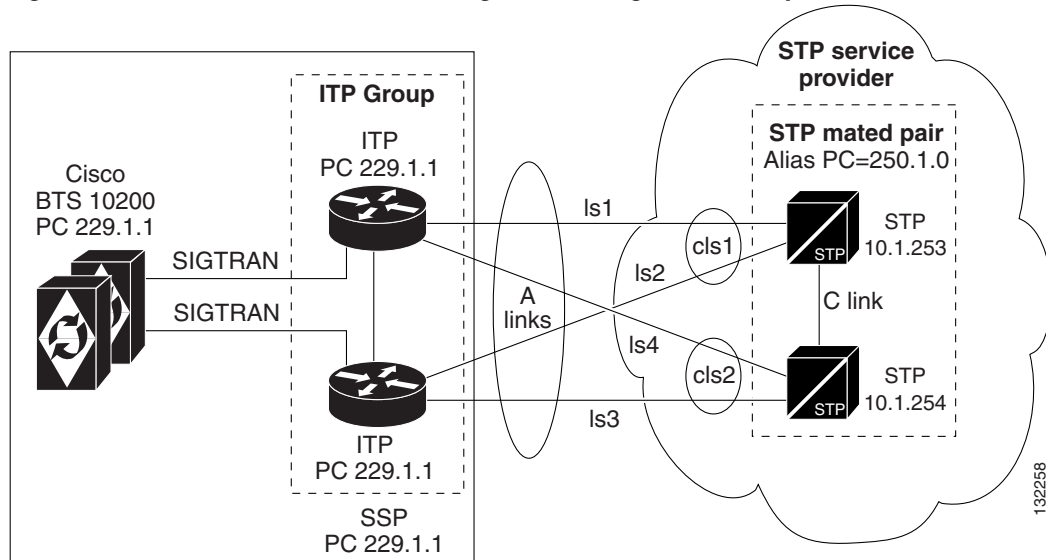

In an ITP group (the Distributed MTP feature) configuration, each ITP acts as a physical signaling gateway process (SGP). Two of these physical signaling gateway processes can be connected together to form one logical signaling gateway (SG). In this configuration, both ITPs share the same point code value. Note that this form of redundancy is not available for the 7507 ITP, since it has internal hardware redundancy. It is available for the 2651 and 7300 series ITPs.

The Shared Point Code configuration provides the following benefits:

- There is less charge from the service provider for A-link connections, which are typically used for the Shared Point Code solution, than D-link connections, which are typically used for the Mated STP-Pair solution.
- The BTS and ITPs share the same point code value, thereby requiring fewer point codes in the network.
- There is full hardware redundancy support between ITPs.
- High volume SS7 traffic can be supported by a single point code.

This configuration has the following restrictions:

- GTT is not supported on the ITP and must be performed on the service provider's STP.
- Geographical separation of ITPs is not supported. ITPs must be colocated.
- Currently, a pair of ITPs is required for each OPC on the BTS 10200. In the Mated STP-Pair solution, only two ITPs are required, regardless of the number of OPCs on the BTS 10200.
- Approximately half of the SS7 traffic of each ITP goes across the inter-ITP connection. Therefore, the traffic between the ITPs is comparatively heavier than that of the Mated STP-Pair configuration. This extra processing requirement reduces the amount of processing power that is available for sending and receiving traffic on links that connect to the SS7 service provider, effectively reducing the amount of allowable links on each ITP platform in an ITP group by half. "As a result, the two ITPs in an ITP group can only have a total number of SS7 links equal to that of one ITP that is not configured in an ITP group."
- If one ITP in the ITP group loses all IP communication, both ITPs will become isolated from each other. The ITP that has lost all IP communication will also not be able to communicate with the BTS. Its default behavior is to send a UPU to the network, which will stop all traffic towards the BTS, even though the other ITP is still functional.
- The Cisco 7507 is not available for ITP group mode. Only the 2651, 7206, and 7301 are supported.

Shared Point Code Configuration Connecting With E-Links

An "E" (extended) link configuration is a variation of the Shared Point Code configuration, but it serves as a backup in case all A-link connections become unavailable. It has the basic provisioning setup, benefits, and limitations as the Shared Point Code with A-links configuration. [Figure 1-6](#) shows how the BTS and ITP can use E links to communicate with the service provider.

Figure 1-6 Shared Point Configuration with E Links)

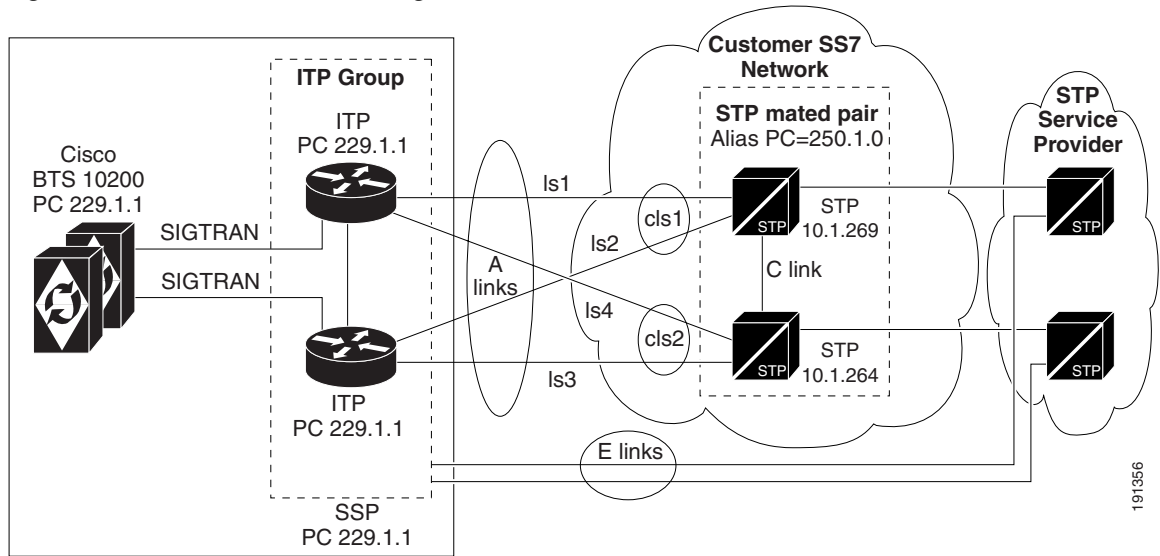

Shared Point Code Configuration Connecting With F-Links

An “F” (fully associated) link configuration is a variation of the Shared Point Code solution that uses A-links, except that, instead of connecting to an STP via A-links, it connects to another signaling end point (SEP), an SSP or SCP, in the SS7 network via fully associated F-links. In this configuration, the BTS and ITP usually function as a PBX. An F link configuration has the basic setup and list of benefits and restrictions as the Shared Point Code with A-links configuration. Figure 1-7 shows a typical F link configuration.

Figure 1-7 Shared Point Configuration with F Links)

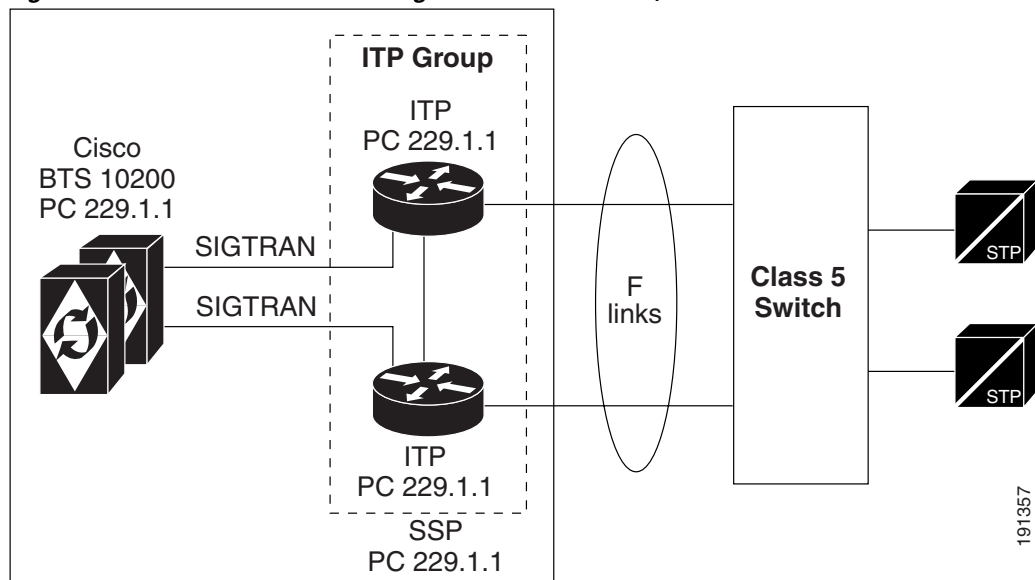

NSO Configuration with A and F Links

The BTS 10200 term for these profiles is ITP group, which is the Distributed MTP configuration on an ITP. For the Cisco BTS10200 Softswitch to support Distributed MTP on ITPs, the

SG Group must be provisioned with parameter `sg-grp-mode=itp-group` with only one SG in that group whose parameter `internal-redundancy-mode=none`. The A link and F link profiles are identical because the BTS 10200 and the SG share the same point code.

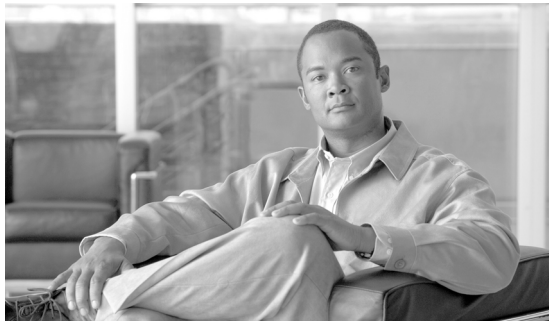

CHAPTER 2

Provisioning Basic SS7 Configurations

Revised: May 7, 2007, OL-12779-02

This chapter describes the provisioning process for the Cisco ITP and BTS 10200 Softswitch for Shared Point Code and Mated STP-Pair configurations and contains the following sections:

- [ITP AS and ASP Configuration Example](#)
- [Mated STP-Pair Configuration Example](#)
- [Shared Point Code Configuration Example](#)

ITP AS and ASP Configuration Example

The IETF SIGTRAN standard defines how a signaling gateway, such as the Cisco ITP, routes traffic from the SS7 service provider towards a SIGTRAN enabled IP end point, such as the Cisco BTS 10200 Softswitch. This section provides a basic example and diagram for configuring an application server (AS) and application server process (ASP) on the ITP. Please refer to [Figure 2-1](#) when reading this example.

The following components are configured in this example:

- **Routing Key**—A set of SS7 parameters, such as DPC, OPC, SI, CIC range, and SSN, that uniquely define the range of signaling traffic to be handled by a particular application server (AS).
- **Routing Context**—A value that uniquely defines a routing key.
- **Application Server (AS)**—A logical entity serving a specific routing key. An example of an application server is a switch element handling all call processing for a unique range of SS7 network trunks, identified by an SS7 SI, DPC, OPC, Subsystem, and CIC-range. The AS will contain two application server processes, one of which is actively processing traffic. Note that there is a one-to-one relationship between an AS and a routing key.
- **Application Server Process (ASP)**—An active or standby process instance of an application server (in the BTS, it is either the active or standby BTS signaling gateway adapter or TCAP signaling adapter software process). An ASP is defined by its SCTP endpoint information (two IP addresses and port) and may be configured to process signaling traffic within more than one application server.

SCTP Provisioning

Provisioning SCTP Associations M3UA Layer

The SIGTRAN M3UA layer transmits ISUP messages between the BTS 10200 Softswitch and the ITP. This is accomplished by provisioning the BTS 10200 Softswitch with a platform-id of CAXXX, usually CA146, and with a remote IP port number for M3UA, generally 2905. You can configure another port number, as long as the port number is also configured on the ITP when the M3UA service is defined. The local port number that the BTS uses for M3UA communication is usually 11146, which was chosen as part of the BTS port naming convention.

Provisioning SCTP Associations SUA Layer for LNP and 800 Services

The SIGTRAN SUA layer is utilized to handle LNP and 800 services between the BTS feature server (FSAIN) and the ITP. This is accomplished by provisioning the BTS FSAIN with a platform-id of FSXXX, usually FSAIN205, and with the remote IP port number 14001. You can configure another port number, as long as the port number is also configured on the ITP when the SUA service is defined. The local port number that the BTS uses for FSAIN communication is usually 12205, which was chosen as part of the BTS port naming convention.

Provisioning SCTP Association SUA Layer for ACAR and CNAM Services

The SIGTRAN SUA layer is also utilized to handle automatic callback and automatic recall (ACAR) and calling name delivery (CNAM) services between the BTS feature server (FSPTC) and the ITP. This is accomplished by provisioning the BTS FSPTC with a platform-id of FSXXX (usually FSPTC235) and with remote IP port number 14001. You can configure another port number as long as the port number is also configured on the ITP when the SUA service is defined. The local port number that the BTS uses for FSPTC communication is usually 12235, which was chosen as part of the BTS port naming convention.

Configuring SCTP Parameters

The SCTP timers on the BTS and the ITP side need to be aligned properly for failure detection. Parameters such as rto-min, rto-max, and max-path-retrans should be the same on both sides of the SCTP association. If they are not the same, each side will have its own retransmit interval and will determine there is a network failure at different times. The bundle-timeout should be tuned when a guaranteed round-trip time is needed.

Figure 2-1 Configuring an AS and ASP on the ITP

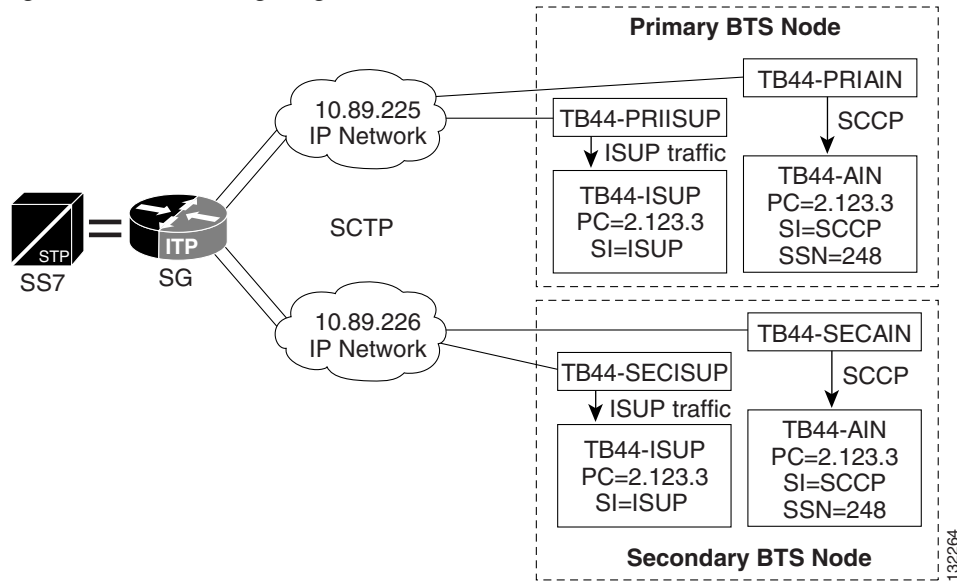

Cisco ITP Configuration

The following ASP configuration defines the primary side TSA process on FSAIN. TB44-PRIAIN is the variable name of the ASP, 12205 is the remote (BTS 10200) port number, 14001 is the local (Cisco ITP) port number, and SCCP User Adaptation (SUA) defines the layer 3 SIGTRAN protocol that is utilized to transfer information to the ASP. In this definition, there are also the two IP addresses of the Cisco BTS10200 Softswitch that the TSA process on FSAIN uses for SUA communication.

! The following defines the local port defined for M3UA traffic on ITP

```
cs7 m3ua 2905
  local-ip 10.89.225.200
  local-ip 10.89.226.200
```

! The following defines the local port defined for SUA traffic on ITP

```
cs7 sua 14001
  local-ip 10.89.225.200
  local-ip 10.89.226.200
```

```
cs7 asp TB44-PRIAIN 12205 14001 sua
  remote-ip 10.89.225.234
  remote-ip 10.89.226.234
```

!

! The following configuration defines information for the secondary side TSA process on FSAIN.

!

```
cs7 asp TB44-SECAIN 12205 14001 sua
  remote-ip 10.89.225.235
  remote-ip 10.89.226.235
```

!

! The following configuration defines an ASP that uses M3UA to transfer information to the ASP. This configuration is for the primary side SGA process.

!

```
cs7 asp TB44-PRIISUP 11146 2905 m3ua
```

```

remote-ip 10.89.225.234
remote-ip 10.89.226.234
!
! The following configuration is for the secondary side SGA process.
!
cs7 asp TB44-SECISUP 11146 2905 m3ua
remote-ip 10.89.225.235
remote-ip 10.89.226.235
!
! The AS configuration defines the routing key, which defines a filter for the traffic
! that will be sent towards the associated ASPs. The filter is based on parameters within
! incoming messages from the SS7 network, such as DPC, OPC, CIC range, service
! indicator, and SSN.
! The following line of the AS configuration defines an AS name of TB44-ISUP and also
! says that the AS is defined for M3UA.
!
cs7 as TB44-ISUP m3ua
!
! The following line defines the routing key. It is identified by a routing context value
! of 1. It also includes a DPC value of 2.1.3 (which is the BTS OPC). The next parameter
! in the routing key is the service indicator, SI ISUP. This means that when a layer 4 SS7
! message (such as an ISUP message) is received from the SS7 network, if the DPC in the
! MTP3 header is 2.1.3 and the SI indicates ISUP, it will be processed by this AS.
!
routing-key 1 2.1.3 si isup
!
! The following lines of the AS configuration defines the two associated ASPs. These
! represent the active and standby BTS processes, one of which will actually do the
! processing.
!
asp TB44-PRIISUP
asp TB44-SECISUP
!
! The following line of the AS configuration indicates that override mode is being used
! for this AS. Either ASP TB44- PRIISUP or ASP TB44-SECISUP will process the
! traffic (as opposed to a load-share mode, which is not supported).
!
traffic-mode override
!
! Note that network-appearance is set to 1. This was a work around for BTS release 4.4 and
! should not be provisioned at all in release 4.5.
network-appearance 1

! The following AS definition is for processing AIN traffic. Instead of defining M3UA
! as the SIGTRAN protocol, which is used to communicate with this AS, SUA is
! the defined protocol. In addition to the DPC and SI definitions in the routing key
! definition, an SSN value of 248 is also used to further refine the filter.
!
cs7 as TB44-AIN sua
routing-key 2 2.1.3 si sccp ssn 248
asp TB44-SECAIN
asp TB44-PRIAIN
traffic-mode override
network-appearance 1
!

```

Overlapping AS Configurations

The following AS configuration example is similar to the one in the previous subsection but has more information in the routing key definition.

In the following AS configuration, the routing key has a routing context value of 10. The routing key defined DPC value is 2.1.3. The routing key also defines an OPC value of 3.50.3. This OPC has a mask value of 255.255.255, which means all bits of the OPC will be considered when routing. It defines an SI of ISUP and a CIC range of 1 to 23. Therefore, this AS will route messages towards ASP PRI_ISUP_BTS2 or SEC_ISUP_BTS2, if the message has the following criteria: the DPC is 2.1.3, the OPC is 3.50.3, the service indicator is ISUP, and the CIC range is between 1 and 23.

Note that the network-appearance is set to 1. This is valid for BTS release 4.4 and should not be provisioned at all in release 4.5.

```
!
cs7 as ISUP_BTS1 m3ua
routing-key 10 2.1.3 opc 3.50.3 255.255.255 si isup cic 1 23
asp PRI_ISUP_BTS2
asp SEC_ISUP_BTS2
traffic-mode override
  network-appearance 1
!
```

This AS (ISUP_BTS1) and the AS of the previous section (TB44-ISUP) both route ISUP messages from the SS7 network that have DPC values of 2.1.3. The ITP routes towards the ASP that matches best when the DPC in the incoming ISUP message is 2.1.3. ISUP_BTS1 requires that four parameters from the incoming SS7 message match its routing key. TB44-ISUP only requires that two parameters match. If all four parameters of routing-key 10 match, then ISUP_BTS1 will be chosen. If only three parameters of routing-key 10 match, then routing key 1 is a better match, and TB44-ISUP will be chosen to process the message.

GTT Configuration

When an ITP pair is connected to a service provider's network using a Mated STP-Pair configuration, the ITP pair can be used as an STP pair. In this case, GTT can be performed on the ITP. The GTT table needs to be populated for remote subsystems and preserved as part of the start-up configuration. For additional information on populating the ITP GTT table, refer to the following URL:

<http://www.cisco.com/en/US/products/sw/wirelssw/ps1862/index.html>.

Extra steps are needed to save it in the flash and have the startup procedure load it from the flash. The following is an example procedure:

-
- Step 1** On ITP1, add the GTT entry in the global config mode:
- ```
cs7 gtt selector acar_sel
gta 469255 pcssn 1.1.30 pcssn ssn 251
gta 469256 pcssn 1.1.31 pcssn ssn 251
```
- Step 2** On ITP1, save the GTT table in the privileged enable mode:
- ```
cs7 save gtt-table flash:gttdata.txt
```
- Step 3** On ITP1, save the configuration:
- ```
copy run start
```
- Step 4** Swap the flash card between ITP1 and ITP2.
- Step 5** On ITP2, load the GTT table in the global config mode:
- ```
cs7 gtt load flash:gttdata.txt
```
- Step 6** Swap the flash card between ITP1 and ITP2.
- Step 7** On ITP2, save the GTT table in the privileged enable mode:

Mated STP-Pair Configuration Example

```
cs7 save gtt-table flash:gttdata.txt
```

Step 8 On ITP2, save the configuration:

```
copy run start
```

Cisco BTS 10200 Softswitch Configuration

Each of the following configuration examples include BTS10200 example provisioning that is related to the associated profile. For a complete description of provisioning SS7 related objects on the BTS 10200, please refer to the following URL:

http://www.cisco.com/univercd/cc/td/doc/product/voice/bts10200/bts4_1/provgd/41_ss7.htm

The DSCP is now configured in the ca-config table. For information about the SCTP-DSCP token, refer to the Command Line Interface Guide

(http://www.cisco.com/univercd/cc/td/doc/product/voice/bts10200/bts5_0/cli_cp/clipc5.pdf).

Mated STP-Pair Configuration Example

A Mated STP-Pair configuration is used to access the SS7 service provider network signaling transfer point (STP), usually using SS7 D- links, although A-links can also be used to connect to an SEP in the network. With a Mated STP-Pair configuration, ITPs support GTT, and geographical separation is available.

This section provides an example and diagram for a basic Mated STP-Pair configuration. Please refer to [Figure 2-2](#) when reading this example.



Note

The ITP configuration may vary slightly depending on the ITP platform.

Figure 2-2 Mated STP-Pair Configuration

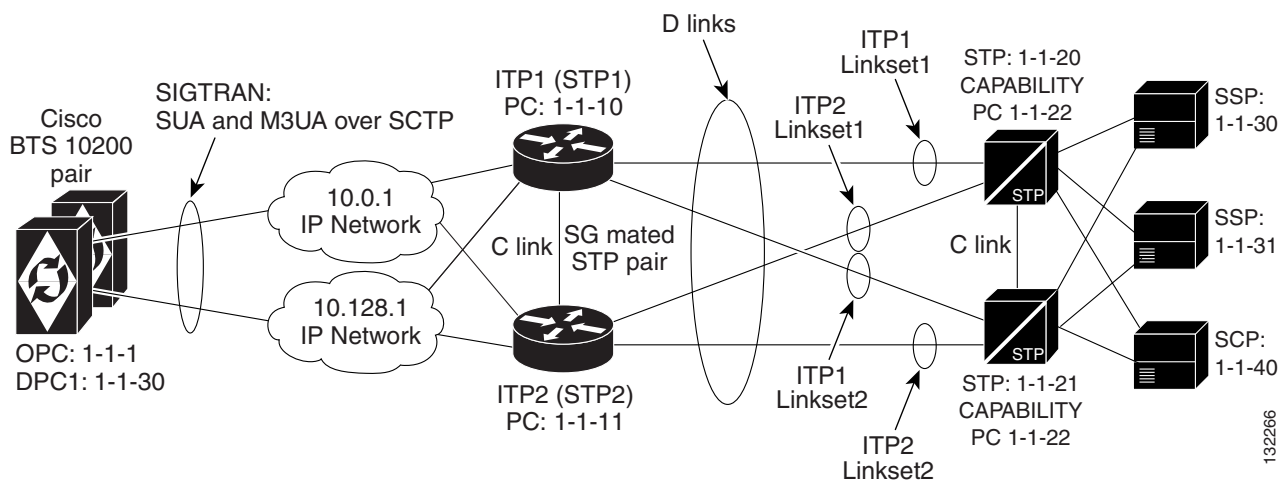

Cisco ITP Configuration

ITP1 Configuration

ITP1 is the first ITP in the sg-pair (each ITP in the sg-pair functions as an STP).

```

Current configuration : 3470 bytes
!
version 12.2
service timestamps debug datetime msec
service timestamps log datetime msec
no service password-encryption
!
hostname ITP1
!
boot-start-marker
boot system flash c2600-ntp-mz.topsail_s_nightly_040915
boot-end-marker
!
redundancy inter-device
!
enable secret 5 $1$XC0U$j0Y2wFRoks2pocHa1gHhi0
enable password cisco
!
memory-size iomem 20
ip subnet-zero
!
ip domain-name cisco.com
ip name-server 10.0.0.6
!
!
! Note that for the Mated STP-Pair configuration (SG Mated Pair), the local
! point code value is 1.1.10, which is different than the BTS OPC and the other ITP (ITP1)
! that makes up the SG Mated Pair.
!
cs7 variant ANSI
cs7 point-code 1.1.10
!
controller E1 0/0
 framing NO-CRC4
 channel-group 0 timeslots 1
!
controller E1 0/1
 framing NO-CRC4
 channel-group 0 timeslots 1
!
controller E1 0/2
 shutdown
!
controller E1 0/3
 shutdown
!
interface Serial0/0:0
 description connect to link 0 of STP 1-1-20
 no ip address
 encapsulation mtp2
 no clns route-cache
!
interface Serial0/1:0
 description connect to link 0 of STP 1-1-21

```

```

no ip address
encapsulation mtp2
no clns route-cache

interface FastEthernet0/0
ip address 10.0.1.54 255.255.0.0
speed auto
half-duplex
no clns route-cache
!
interface FastEthernet0/1
ip address 10.128.1.239 255.255.0.0
speed auto
half-duplex
no clns route-cache
!
!
! In the Mated STP-Pair configuration, instead of defining a cs7 group, as is done in
! the Shared Point Code configuration, a "local-peer" and "mated-sg" are defined. Here,
! we define the local-peer, which is the local definition for the C-link connection
! between the two ITPs that make up the redundant STP pair.
!
cs7 local-peer 7000
local-ip 10.0.1.54
local-ip 10.128.1.239
!
! Linkset definitions. Note that the number after 'link' represents SLC.
!
cs7 linkset lset1chn 1.1.20
link 0 Serial0/0:0
!
cs7 linkset lset2chn 1.1.21
link 0 Serial0/1:0
!
! C-link linkset definition. Here the point code value and IP information for
! the mated-sg is defined. Note that the local IP information is defined in
! the local-peer definition above.
!
cs7 linkset c-link 1.1.11
link 0 sctp 10.0.1.55 10.128.1.240 7000 7000
!
! SS7 Route Definitions
!
! In the following entries, note the following:
! 1) All of the routes towards all DPCs are configured with equal priority when using
lset1chn or
!     lset2chn.
! 2) There are lower priority routes towards each destination across the c-link.
! 3) Routing towards the capability PC of the adjacent STPs is treated as if the capability
PC is a DPC beyond the STP.
!
cs7 route-table system
update route 1.1.30 255.255.255 linkset lset1chn priority 1
update route 1.1.30 255.255.255 linkset lset2chn priority 1
update route 1.1.31 255.255.255 linkset lset1chn priority 1
update route 1.1.31 255.255.255 linkset lset2chn priority 1
update route 1.1.40 255.255.255 linkset lset2chn priority 1
update route 1.1.40 255.255.255 linkset lset1chn priority 1
!
! Lower priority C-link routes
!
update route 1.1.30 255.255.255 linkset c-link priority 2
update route 1.1.31 255.255.255 linkset c-link priority 2
update route 1.1.40 255.255.255 linkset c-link priority 2

```

```

!
! Routing to capability point codes of adjacent STPs
!
update route 1.1.22 255.255.255 linkset lset1chn priority 1
update route 1.1.22 255.255.255 linkset lset2chn priority 1
!
! With the mated-sg (Mated STP-Pair configuration), you must also define a connection
! between the ITPs to pass SIGTRAN specific state information and other data.
! This is done by defining the local IP information in the "cs7 sgmp" configuration
! and the peer IP information in the "cs7 mated-sg" configuration.
!
cs7 sgmp 9101
  local-ip 10.0.1.54
  local-ip 10.128.1.239
!
cs7 mated-sg ITP2 9101
  remote-ip 10.0.1.55
  remote-ip 10.128.1.240
!
! The M3UA definition that declares local IP addresses and port number
!
cs7 m3ua 2905
  local-ip 10.0.1.54
  local-ip 10.128.1.239
  keepalive 2000
!
! Here, as with all configurations, there are a minimum of two ASPs defined
! for each AS, one for the primary BTS node and one for the Secondary.
! In reality, there will be at least one for each user part on the BTS10200,
! so if you have a TCAP service going over SUA and ISUP traffic, you will
! have a total of at least four ASPs: primary ISUP, secondary ISUP, primary
! TCAP service, and secondary TCAP service.
!
!
! 2905 is the local port value. The remote IP addresses are the BTS IP addresses.
! They are also obtained through the fully-qualified domain name (FQDN) that is an SGA
command line argument.
!
cs7 asp PriCaIsupAsp 11146 2905 m3ua
  remote-ip 10.0.1.5
  remote-ip 10.128.1.2
!
cs7 asp SecCaIsupAsp 11146 2905 m3ua
  remote-ip 10.0.1.6
  remote-ip 10.128.1.3
!
! Note that the routing key is a very simple one. It has a routing context of 1
! defined, the DPC (BTS OPC) of 1.1.1 defined, and a service indicator of ISUP defined.
! This means that all traffic coming from the SS7 service provider network that has
! a DPC of 1.1.1 and a service indicator of ISUP will be sent to either PrimaryBtsIsupAsp
! or SecondaryBtsIsupAsp (depending on which one is active).
!
! The traffic mode is always set to override (not loadshare), as with the current
implementation, only the override application server traffic mode is supported. In the
case of override-traffic mode, the reception of ASP active messages at the SGP causes the
redirection of all traffic for the AS to the ASP that sent the ASP active message.
!
! In Cisco BTS 10200 Softswitch software release 4.4 only, there is a work around that
! requires network-appearance to be configured with a value of 1. In Cisco BTS 10200
! Softswitch release 4.5, this work-around is removed and network-appearance should not
! be provisioned on the ITP.
!
cs7 as CaIsupAs m3ua
  routing-key 1 1.1.1 si isup

```

```

asp PriCaIsupAsp
asp SecCaIsupAsp
traffic-mode override
network-appearance 1
!
! The SUA definition that declares local IP addresses and port number
!
cs7 sua 14001
  local-ip 10.0.1.54
  local-ip 10.128.1.239
  keepalive 2000
!
! Here we are defining an ASP that will process AIN related traffic.
!
cs7 asp PrimFsAinAsp 12205 14001 sua
  remote-ip 10.0.1.5
  remote-ip 10.128.1.2
!
cs7 asp SecFsAinAsp 12205 14001 sua
  remote-ip 10.0.1.6
  remote-ip 10.128.1.3
!
cs7 asp PriFsPtcAsp 12235 14001 sua
  remote-ip 10.0.1.5
  remote-ip 10.128.1.2
!
cs7 asp SecFsPtcAsp 12235 14001 sua
  remote-ip 10.0.1.6
  remote-ip 10.128.1.3
!
!
! The following AS is defined for LNP related message flows. The routing context
! value is 4, the DPC (BTS OPC) is 1.1.1, the service indicator is SCCP and the
! subsystem number is 247. This means that any message received from the SS7
! service provider that has a DPC of 1.1.1, a service indicator of SCCP and an
! SSN of 247 will be sent to either PrimaryBtsAinAsp or SecondaryBtsAinAsp
! (depending on which one is active).
!
cs7 as FsAinLnpAs sua
  routing-key 4402 1.1.1 si sccp ssn 247
  asp PriFsAinAsp
  asp SecFsAinAsp
  traffic-mode override
!
cs7 as FsAin800TAs sua
  routing-key 4404 1.1.1 si sccp ssn 254
  asp PriFsAinAsp
  asp SecFsAinAsp
  traffic-mode override
!
cs7 as FsAin800AAs sua
  routing-key 4403 1.1.1 si sccp ssn 248
  asp PriFsAinAsp
  asp SecFsAinAsp
  traffic-mode override
!
cs7 as FsPtcCnamAs sua
  routing-key 4404 1.1.1 si sccp ssn 232
  asp PriFsPtcAsp
  asp SecFsPtcAsp
  traffic-mode override
!
cs7 as FsPtcAcarAs sua

```

```

routing-key 4405 1.1.1 si sccp ssn 251
asp PriFsPtcAsp
asp SecFsPtcAsp
traffic-mode override
!
cs7 gtt load flash:gttdata.txt
!

```

ITP2 Configuration

ITP2 is the second ITP in the sg-pair (each ITP in the sg-pair functions as an STP). For the ITP2 configuration, please refer to the comments that were made in the ITP1 configuration.

```

Current configuration : 4054 bytes
!
version 12.2
service timestamps debug datetime msec
service timestamps log datetime msec
no service password-encryption
!
hostname ITP2
!
boot-start-marker
boot system flash 2600/c2600-ity-mz.topsail_s_nightly_040915
boot-end-marker
!
redundancy inter-device
!
enable secret 5 $1$B6u2$gI4fFgj0Qo5XppDSWJDfI.
enable password cisco
!
!
memory-size iomem 10
ip subnet-zero
!
ip domain-name cisco.com
ip name-server 10.0.0.6
!
cs7 variant ANSI
!
! Note that for the Mated STP-Pair configuration (SG Mated Pair) configuration, the local
! point code value is 1.1.11, which is different than the BTS OPC and the other ITP (ITP1)
! that makes up the SG Mated Pair.
!
cs7 point-code 1.1.11
!
controller E1 0/0
framing NO-CRC4
channel-group 0 timeslots 1
!
controller E1 0/1
framing NO-CRC4
channel-group 0 timeslots 1
!
controller E1 0/2
shutdown
!
controller E1 0/3
shutdown
!

```

```

interface FastEthernet0/0
 ip address 10.0.1.55 255.255.0.0
 speed auto
 half-duplex
 no clns route-cache
!
interface FastEthernet0/1
 ip address 10.128.1.240 255.255.0.0
 speed auto
 half-duplex
 no clns route-cache
!
interface Serial0/0:0
 description connect to link 1 of STP 1-1-20
 no ip address
 encapsulation mtp2
 no clns route-cache

interface Serial0/1:0
 description connect to link 1 of STP 1-1-21
 no ip address
 encapsulation mtp2
 no clns route-cache
!
!
! local-peer definition
!
cs7 local-peer 7000
 local-ip 10.0.1.55
 local-ip 10.128.1.240
!
!
! Linkset definitions. Note that the number after 'link' represents SLC.
!
cs7 linkset lset1chn 1.1.20
 link 1 Serial0/0:0
!
cs7 linkset lset2chn 1.1.21
 link 1 Serial0/1:0
!
!
! C-link linkset definition.
!
cs7 linkset c-link 1.1.10
 link 0 sctp 10.0.1.54 10.128.1.239 7000 7000
!
cs7 route-table system
 update route 1.1.30 255.255.255 linkset lset1chn priority 1
 update route 1.1.30 255.255.255 linkset lset2chn priority 1
 update route 1.1.31 255.255.255 linkset lset1chn priority 1
 update route 1.1.31 255.255.255 linkset lset2chn priority 1
 update route 1.1.40 255.255.255 linkset lset2chn priority 1
 update route 1.1.40 255.255.255 linkset lset1chn priority 1
!
! C-link routes
!
 update route 1.1.30 255.255.255 linkset c-link priority 2
 update route 1.1.31 255.255.255 linkset c-link priority 2
 update route 1.1.40 255.255.255 linkset c-link priority 2
!
! Routing to capabilitypoint codes of adjacent STPs
!
 update route 1.1.22 255.255.255 linkset lset1chn priority 1
 update route 1.1.22 255.255.255 linkset lset2chn priority 1

```

```

!
cs7 sgmp 9101
  local-ip 10.0.1.55
  local-ip 10.128.1.240
!
cs7 mated-sg ITP1 9101
  remote-ip 10.0.1.54
  remote-ip 10.128.1.239
cs7 m3ua 2905
  local-ip 10.0.1.55
  local-ip 10.128.1.240
!
cs7 asp PriCaIsupAsp 11146 2905 m3ua
  remote-ip 10.0.1.5
  remote-ip 10.128.1.2
!
cs7 asp SecCaIsupAsp 11146 2905 m3ua
  remote-ip 10.0.1.6
  remote-ip 10.128.1.3
!
cs7 as CaIsupAs m3ua
  routing-key 1 1.1.1 si isup
  asp PriCaIsupAsp
  asp SecCaIsupAsp
  traffic-mode override
  network-appearance 1
!
cs7 sua 14001
  local-ip 10.0.1.55
  local-ip 10.128.1.240
  keepalive 2000
!
cs7 asp PriFsAinAsp 12205 14001 sua
  remote-ip 10.0.1.5
  remote-ip 10.128.1.2
!
cs7 asp SecFsAinAsp 12205 14001 sua
  remote-ip 10.0.1.6
  remote-ip 10.128.1.3
!
cs7 asp PriFsPtcAsp 12235 14001 sua
  remote-ip 10.0.1.5
  remote-ip 10.128.1.2
!
cs7 asp SecFsPtcAsp 12235 14001 sua
  remote-ip 10.0.1.6
  remote-ip 10.128.1.3
!
cs7 as FsAinLnpAs sua
  routing-key 4402 1.1.1 si sccp ssn 247
  asp PriFsAinAsp
  asp SecFsAinAsp
  traffic-mode override
!
cs7 as FsAin800TAs sua
  routing-key 4401 1.1.1 si sccp ssn 254
  asp PriFsAinAsp
  asp SecFsAinAsp
  traffic-mode override
!
cs7 as FsAin800AAs sua
  routing-key 4403 1.1.1 si sccp ssn 248
  asp PriFsAinAsp

```

```

asp SecFsAinAsp
traffic-mode override
!
cs7 as FsPtcCnamAs sua
routing-key 4404 1.1.1 si sccp ssn 232
asp PriFsPtcAsp
asp SecFsPtcAsp
traffic-mode override
!
cs7 as FsPtcAcarAs sua
routing-key 4405 1.1.1 si sccp ssn 251
asp PriFsPtcAsp
asp SecFsPtcAsp
traffic-mode override
!
cs7 gtt load flash:gttdata.txt
!

```

Cisco BTS10200 Provisioning for a Mated STP-Pair Configuration

The local IP addresses and port are determined by command line arguments that are passed to the SGA process and TSA processes when they start up. An example SGA command line is:

```

Args=-t 1 -h crit-aSYS11CA.ipclab.cisco.com -p 11146 -mdldir ../mdl -mdltracedir
../mdltrace -mdltestmode 0 -mdlloadmdo 0 -mdltriggertimer 200 -mdlgarbagetimer 5146
-resetcics 1 -fcmtimer 900 -fcmparalleljobs 4

```

In this list of arguments, the -h argument: crit-aSYS11CA.ipclab.cisco.com, is a fully qualified domain name (FQDN) that resolves to two local IP addresses. In most cases, the FQDN can be viewed in the /etc/hosts file. To determine the IP addresses to which the FQDN resolves, type nslookup <FQDN>.

The following example configures the BTS 10200 in the Mated STP-Pair Configuration.

```

#####
# CA Configuration
#####
add ca-config type=MGCP-INIT-TERMS;value=160;datatype=integer;
add ca-config type=MGCP-INIT-DURATION;value=5;datatype=integer;
add ca-config type=MGCP-ICMP-PING-RETRANSMIT-DURATION;value=5;datatype=integer;
add ca-config type=MGCP-ICMP-PING-RETRY-COUNT;value=5;datatype=integer;
add ca-config type=MGCP-MAX-UNREACH-COUNT;value=5;datatype=integer;
add ca-config type=MGCP-MAX-FAULT-COUNT;value=5;datatype=integer;
add ca-config type=MGCP-ADM-RESP-TIME;value=300;datatype=integer;
add ca-config type=MGCP-SIG-TOS-LOWDELAY;value=Y;datatype=boolean;
add ca-config type=MGCP-SIG-TOS-PRECEDENCE;value=1;datatype=integer;
add ca-config type=MGCP-SIG-TOS-RELIABILITY;value=Y;datatype=boolean;
add ca-config type=MGCP-SIG-TOS-THROUGHPUT;value=Y;datatype=boolean;
#
# CA & FS
#
add call-agent id=CA146; tsap-addr-sidea=hrn11ca; mgw-monitoring-enabled=N;
add feature-server id=FSAIN205; tsap-addr-sidea=hrn11ca:11205; type=AIN;
add feature-server id=FSPTC235; tsap-addr-sidea=hrn11ca:11235; type=PTC;
#
# SIGTRAN components
#
add user-part-variant id=ANSISS7_GR317;
#
# Note for the Mated STP-Pair configuration, there are two SGs defined for redundancy.
# They are essentially mated STPs. This is different than the A, F, or E link
# configurations, which derive redundancy at the SGP level.
#

```

```

add sg id=sg1; description=Signaling gateway 1;
add sg id=sg2; description=Signaling gateway 2;
#
# In the Mated STP-Pair configuration The SG-GRP has two SGs defined in the SG-GRP. The
# A,F, and E link configurations must only have one SG defined in an SG-GRP.
#
add sg-grp id=sg-grp1; sg1-id=sg1; sg2-id=sg2 description=SG group 1;

#
# In the Mated STP-Pair configuration, there is only one SGP per SG. Note that the
# two SGPs defined here have a one-to-one correspondence to the SGs that were
# defined above. This is in contrast to the A,F, and E link configurations,
# which must have two SGPs per SG.
#
add sgp id=sg1-sgp1 ; sg-id=sg1; description=SG process 1 for sg1;
add sgp id=sg2-sgp1 ; sg-id=sg2; description=SG process 1 for sg2;

add opc id=opc1; point-code=1-1-1; description=OPC; point-code-type=ANSI_CHINA;
add dpc id=dpc1; point-code=1-1-30; description=DPC 1; point-code-type=ANSI_CHINA;
add dpc id=dpc2; point-code=1-1-31; description=DPC 2; point-code-type=ANSI_CHINA;
#
# The ISUP routing keys
#
add routing-key id=rk1; opc-id=opc1; sg-grp-id=sg-grp1; si=ISUP; rc=1; platform-id=CA146;

add call-ctrl-route id=dpc1-route1; dpc-id=dpc1; routing-key-id=rk1; si=isup;
user-part-variant-id= ANSISS7_GR317
add call-ctrl-route id=dpc2-route1; dpc-id=dpc2; routing-key-id=rk1; si=isup;
user-part-variant-id= ANSISS7_GR317;

add sctp-assoc-profile id=sctp-prof;

#
# The SCTP associations
# Note that the chosen id name in this statement reflects the fact that this is the
# SCTP association for SGP1 of SG1
#
add sctp-assoc id=sg1-sgp1-sctp; sgp-id=sg1-sgp1; sctp-assoc-profile-id=sctp-prof;
platform-id=CA146; remote-port=2905; remote-tsap-addr1=10.0.1.54;
remote-tsap-addr2=10.128.1.239; ip-tos-precedence=ROUTINE;

add sctp-assoc id=sg2-sgp1-sctp; sgp-id=sg2-sgp1; sctp-assoc-profile-id=sctp-prof;
platform-id=CA146; remote-port=2905; remote-tsap-addr1=10.0.1.55;
remote-tsap-addr2=10.128.1.240; dip-tos-precedence=ROUTINE;

#
# Dial plan profile
#
add digman-profile id=pretrans;
add digman id=pretrans; rule=1; match-string=^*; replace-string=&; match-noa=any;
replace-noa=VSC;
add digman id=pretrans; rule=2; match-string=^#; replace-string=&; match-noa=any;
replace-noa=VSC;
add digman-profile id=ani_20;
add digman id=ani_20; rule=1; match-string=^20; replace-string=none;
add dial-plan-profile id=dp-1; nanp-dial-plan=Y; description=NA dial plan profile;
dnis-digman-id=pretrans; ani-digman-id=ani_20;
#
# SS7 TG
#
add ss7-ansi-tg-profile ID=ansi-tg-prof;
add trunk-grp ID=1; call_agent_id=CA146; tg_type=SS7; direction=BOTH;
tg_profile_id=ansi-tg-prof; call-ctrl-route-id=dpc1-route1; dial-plan-id=dp-1;
description=TG to DPC 1; MGCP_PKG_TYPE=T;

```

```

add trunk-grp ID=2; call_agent_id=CA146; tg_type=SS7; direction=BOTH;
tg_profile_id=ansi-tg-prof; call-ctrl-route-id=dpc2-route1; dial-plan-id=dp-1;
description=TG to DPC 2; MGCP_PKG_TYPE=T;
#
# MGW
#
add mgw-profile id=as5300-prof; vendor=Cisco; mgcp-hairpin-supp=n; MGCP_RSIPSTAR_SUPP=N;
MGCP_TERM_INIT_LEVEL=0; RBK_ON_CONN_SUPP=N; MGCP_VERSION=MGCP_1_0; mgcp-max2-retries=3;
fax-t38-camode-supp=Y; mgcp-keepalive-interval=60; mgcp-keepalive-retries=10;
mgcp-t-tran=400; mgcp-max1-retries=2; mgcp-t-longtran=5; mgcp-default-pkg=NONE;
MGCP_3WAY_HSHAKE_SUPP=N; mgw_type=AS5300; PC_MPTIME_SUPP=N;

MGCP_VERSION=MGCP_1_0; PC_MPTIME_SUPP=N;
add mgw id=va-5350-23; tsap-addr=va-5350-23.hrndevtest.cisco.com; call-agent-id=CA146;
mgw-profile-id=as5300-prof; type=TGW;
#
# SS7 terminations and trunks
#
add termination prefix=S3/DS1-4/; port-start=1; port-end=31; type=trunk;
mgw-id=va-5350-23;
add termination prefix=S3/DS1-5/; port-start=1; port-end=31; type=trunk;
mgw-id=va-5350-23;
add trunk cic-start=1; cic-end=31; tgn-id=1; mgw-id=va-5350-23;
termination-prefix=S3/DS1-4/; termination-port-start=1; termination-port-end=31;
add trunk cic-start=1; cic-end=31; tgn-id=2; mgw-id=va-5350-23;
termination-prefix=S3/DS1-5/; termination-port-start=1; termination-port-end=31;
#
# SS7 routes, route guides and destinations
#
add route id=dpc1-route; tg_selection=RR; tgn1_id=1;
add route id=dpc2-route; tg_selection=RR; tgn1_id=2;
add route-guide id=dpc1-rg; policy-type=ROUTE; policy-id=dpc1-route;
add route-guide id=dpc2-rg; policy-type=ROUTE; policy-id=dpc2-route;
add destination dest-id=dpc1-dest; call-type=LOCAL; route-type=ROUTE;
route-guide-id=dpc1-rg;
add destination dest-id=dpc2-dest; call-type=LOCAL; route-type=ROUTE;
route-guide-id=dpc2-rg;

#
# TCAP/SUA provisioning for FSAIN, FSPTC
#
add sctp-assoc id=sg1-sgpl-sctp-ain; sgp-id=sg1-sgpl; sctp-assoc-profile-id=sctp-prof;
platform-id=FSAIN205; remote-port=14001; remote-tsap-addr1=10.0.1.54;
remote-tsap-addr2=10.128.1.239; ip-tos-precedence=ROUTINE;

add sctp-assoc id=sg2-sgpl-sctp-ain; sgp-id=sg2-sgpl; sctp-assoc-profile-id=sctp-prof;
platform-id=FSAIN205; remote-port=14001; remote-tsap-addr1=10.0.1.55;
remote-tsap-addr2=10.128.1.240; ip-tos-precedence=ROUTINE;

add sctp-assoc id=sg1-sgpl-sctp-ptc; sgp-id=sg1-sgpl; sctp-assoc-profile-id=sctp-prof;
platform-id=FSPTC235; remote-port=14001; remote-tsap-addr1=10.0.1.54;
remote-tsap-addr2=10.128.1.239; ip-tos-precedence=ROUTINE;

add sctp-assoc id=sg2-sgpl-sctp-ptc; sgp-id=sg2-sgpl; sctp-assoc-profile-id=sctp-prof;
platform-id=FSPTC235; remote-port=14001; remote-tsap-addr1=10.0.1.55;
remote-tsap-addr2=10.128.1.240; ip-tos-precedence=ROUTINE;

add sccp-nw id=1; NET_IND=NATIONAL; SUB_SVC=NATIONAL; HOP_COUNT=3;

add subsystem-profile id=SS_LNP; platform-id=FSAIN205; description=LNP subsystem;
add subsystem-profile id=SS_800A; platform-id=FSAIN205; description=AIN 800 subsystem;
add subsystem-profile id=SS_800T; platform-id=FSAIN205; description=IN1 800 subsystem;
add subsystem-profile id=SS_CNAM; platform-id=FSAIN205; description=CNAM subsystem;

```

```

add subsystem-profile id=SS_ACAR; platform-id=FSPTC235; description=ACAR subsystem;

add subsystem id=SS_LNP; opc-id=opc1; local-ssn=247; remote-ssn=247; sccp-nw-id=1;
SCCP_VERSION=ANS92; TCAP_VERSION=ANS92; APPLICATION_VERSION=AIN01;
add subsystem id=SS_800A; opc-id=opc1; local-ssn=248; remote-ssn=248; sccp-nw-id=1;
SCCP_VERSION=ANS92; TCAP_VERSION=ANS92; APPLICATION_VERSION=AIN01;
add subsystem id=SS_CNAM; opc-id=opc1; local-ssn=232; remote-ssn=232; sccp-nw-id=1;
SCCP_VERSION=ANS92; TCAP_VERSION=ANS92; APPLICATION_VERSION=IN1;
add subsystem id=SS_800T; opc-id=opc1; local-ssn=254; remote-ssn=254; sccp-nw-id=1;
SCCP_VERSION=ANS92; TCAP_VERSION=ANS92; APPLICATION_VERSION=IN1;
add subsystem id=SS_ACAR; opc-id=opc1; local-ssn=251; remote-ssn=251; sccp-nw-id=1;
SCCP_VERSION=ANS92; TCAP_VERSION=ANS92; APPLICATION_VERSION=IN1;

add routing-key id=rk_lnp; opc-id=opc1; sg-grp-id=sg_grp1; si=SCCP; rc=4402;
PLATFORM_ID=FSAIN205; ssn-id=SS_LNP;
add routing-key id=rk_800a; opc-id=opc1; sg-grp-id=sg_grp1; si=SCCP; rc=4403;
PLATFORM_ID=FSAIN205; ssn-id=SS_800A;
add routing-key id=rk_cnam; opc-id=opc1; sg-grp-id=sg_grp1; si=SCCP; rc=4404;
PLATFORM_ID=FSAIN205; ssn-id=SS_CNAM;
add routing-key id=rk_800t; opc-id=opc1; sg-grp-id=sg_grp1; si=SCCP; rc=4401;
PLATFORM_ID=FSAIN205; ssn-id=SS_800T;
add routing-key id=rk_acar; opc-id=opc1; sg-grp-id=sg_grp1; si=SCCP; rc=4405;
PLATFORM_ID=FSPTC235; ssn-id=SS_ACAR;

#
# Provisioned DPC is the STP capability point code
#
add dpc id=stp_cap_pc; point-code=1-1-22; point-code-type=ANSI_CHINA;
description=Capability Point Code of STPs

add feature fname=LNP; feature-server-id=FSAIN205; description=Local number portability;
tdp1=COLLECTED_INFORMATION; tid1=LNP_TRIGGER; ttype1=R;

add ported-office-code digit-string=301-612; in-call-agent=n;

add CA-Config type=DEFAULT-LNP-SLHR-ID; datatype=string; value=slhr_lnp;

add slhr-profile id=slhr_800t; description=Service Logic Host Routing Table for IN1 800
Service;
add slhr-profile id=slhr_lnp; description=Service Logic Host Routing Table for AIN LNP
Service;
add slhr-profile id=slhr_800a; description=Service Logic Host Routing Table for AIN 800
Service;
add slhr-profile id=slhr_cnam; description=Service Logic Host Routing Table for IN1 CNAM
Service;
add slhr-profile id=slhr_acar; description=Service Logic Host Routing Table for ACAR
Service;

add slhr id=slhr_800t; opc-id=opc1; dpc-id=stp_cap_pc; ssn-id=SS_800T; gtt-req=Y; tt=254;
GTT_ADDR_TYPE=CDPN; GTT_ADDR=3;
add slhr id=slhr_lnp; opc-id=opc1; dpc-id=stp_cap_pc; ssn-id=SS_LNP; gtt-req=Y; tt=11;
GTT_ADDR_TYPE=CDPN; GTT_ADDR=3;
add slhr id=slhr_800a; opc-id=opc1; dpc-id=stp_cap_pc; ssn-id=SS_800A; gtt-req=Y; tt=8;
GTT_ADDR_TYPE=CDPN; GTT_ADDR=3;
add slhr id=slhr_cnam; opc-id=opc1; dpc-id=stp_cap_pc; ssn-id=SS_CNAM; gtt-req=Y; tt=5;
GTT_ADDR_TYPE=CLGN; GTT_ADDR=3;
add slhr id=slhr_acar; opc-id=opc1; dpc-id=stp_cap_pc; ssn-id=SS_ACAR; gtt-req=Y; tt=251;
GTT_ADDR_TYPE=CDPN; GTT_ADDR=10;

add sccp-route opc-id=opc1; dpc-id=stp_cap_pc; ssn-id=SS_800T; rk-id=rk_800t;
add sccp-route opc-id=opc1; dpc-id=stp_cap_pc; ssn-id=SS_800A; rk-id=rk_800a;
add sccp-route opc-id=opc1; dpc-id=stp_cap_pc; ssn-id=SS_LNP; rk-id=rk_lnp;
add sccp-route opc-id=opc1; dpc-id=stp_cap_pc; ssn-id=SS_CNAM; rk-id=rk_cnam;
add sccp-route opc-id=opc1; dpc-id=stp_cap_pc; ssn-id=SS_ACAR; rk-id=rk_acar;

```

```

add sccp-route SSN_ID=SS_ACAR; OPC_ID=opc1; DPC_ID=dpc1; RK_ID=rk_acar
add sccp-route SSN_ID=SS_ACAR; OPC_ID=opc1; DPC_ID=dpc2; RK_ID=rk_acar

add pop ID=50901; STATE=tx; COUNTRY=US; TIMEZONE=CDT; LOCAL_7D_DIALING=Y; ITP=N;
ZERO_MINUS=LEC; BLOCK_EAWOPIC=Y; CNAM_OPTION=EXT_LIDB; PIC2_REQD=N; MY_LRN=4692559999;
TREAT_IMS_ANONYMOUS=N; OPC_ID=opc1; ZERO_PLUS_LOCAL=N

#
# Control network entities in-service for ANSI SS7
#
control trunk-grp id=1; mode=forced; target-state=ins;
control trunk-grp id=2; mode=forced; target-state=ins;
equip trunk-termination tgn-id=1; cic=all;
equip trunk-termination tgn-id=2; cic=all;
control trunk-termination tgn-id=1; cic=all; target-state=INS; mode=FORCED;
control trunk-termination tgn-id=2; cic=all; target-state=INS; mode=FORCED;
control sctp-assoc id=sg1-sgpl-sctp; mode=forced; target-state=INS;
control sctp-assoc id=sg2-sgpl-sctp; mode=forced; target-state=INS;
control sctp-assoc id=sg1-sgpl-sctp-ain; mode=forced; target-state=INS;
control sctp-assoc id=sg2-sgpl-sctp-ain; mode=forced; target-state=INS;
control sctp-assoc id=sg1-sgpl-sctp-ptc; mode=forced; target-state=INS;
control sctp-assoc id=sg2-sgpl-sctp-ptc; mode=forced; target-state=INS;
control subsystem id=SS_800T; opc-id=opc; target-state=UIS; mode=FORCED;
control subsystem id=SS_LNP; opc-id=opc; target-state=UIS; mode=FORCED;
control subsystem id=SS_800A; opc-id=opc; target-state=UIS; mode=FORCED;
control subsystem id=SS_CNAM; opc-id=opc; target-state=UIS; mode=FORCED;
control subsystem id=SS_ACAR; opc-id=opc; target-state=UIS; mode=FORCED;
#
# Status commands
#
#status trunk-grp id=1;
#status trunk-grp id=2;
#status trunk-termination tgn-id=1; cic=all;
#status trunk-termination tgn-id=2; cic=all;
#status sctp-assoc id=sg1-sgpl-sctp;
#status sctp-assoc id=sg2-sgpl-sctp;
#status sctp-assoc id=sg1-sgpl-sctp-ain;
#status sctp-assoc id=sg2-sgpl-sctp-ain;
#status sctp-assoc id=sg1-sgpl-sctp-ptc;
#status sctp-assoc id=sg2-sgpl-sctp-ptc;
#status subsystem id=SS_800T; opc-id=opc;
#status subsystem id=SS_LNP; opc-id=opc;
#status subsystem id=SS_800A; opc-id=opc;
#status subsystem id=SS_CNAM; opc-id=opc;
#status subsystem id=SS_ACAR; opc-id=opc;

```

Shared Point Code Configuration Example

A basic Shared Point Code configuration is used when a customer wants an OPC of the BTS to be shared with a point code of the ITP. This usually occurs when the customer wants to access the SS7 service provider network using A-links. It provides a low cost yet fully hardware and network redundant solution. Cost reduction is accomplished by minimizing the number of point codes that are connected to the SS7 service provider network and by connecting via A-links rather than D-links, which require more setup and maintenance.

This section provides an example and diagram for the basic Shared Point Code configuration. Please refer to [Figure 2-3](#) when reading this example.

**Note**

The ITP configuration may vary slightly, depending on the ITP platform.

Figure 2-3 Shared Point Code Configuration

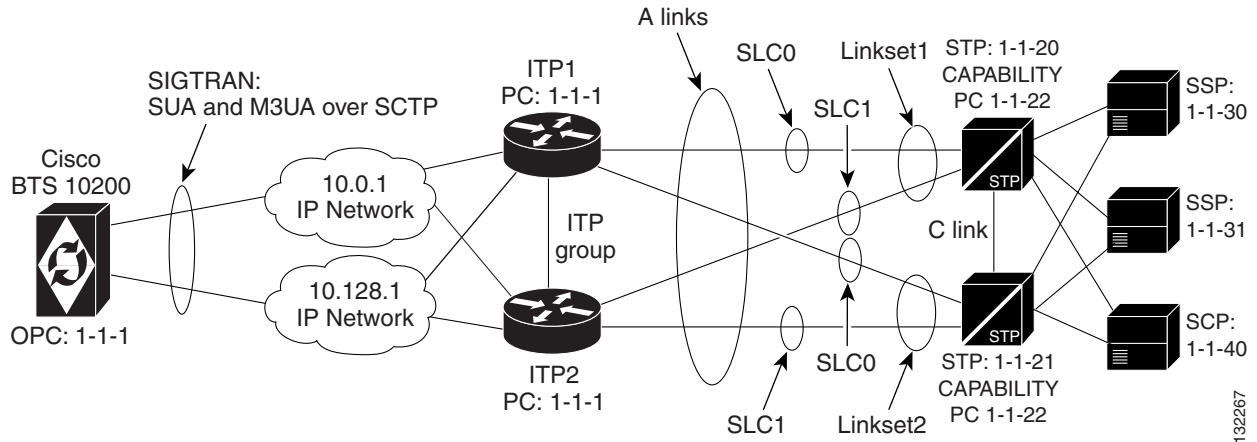

ITP Configuration

This section contains a configuration example for the basic Shared Point Code profile. For additional ITP configuration information, please refer to the ITP Configuration Guide at:

<http://www.cisco.com/univercd/cc/td/doc/product/wireless/moblwrls/itp>

**Note**

When debugging the ITP, the version of the ITP should be noted so the associated ITP manual can be consulted.

ITP1 Configuration

This is the first ITP in the ITP group (the first SGP in the SG).

```
!
Current configuration : 3470 bytes
!
version 12.2
service timestamps debug datetime msec
service timestamps log datetime msec
no service password-encryption
!
hostname ITP1
!
boot-start-marker
boot system flash c2600-itp-mz.topsail_s_nightly_040915
boot-end-marker
!
redundancy inter-device
!
enable secret 5 $1$XCoU$j0Y2wFRoks2pocHa1gHhi0
enable password cisco
```

```

!
! Note that for the Shared Point Code configuration, ipc zone is provisioned to support
the link
! between two ITPs in the ITP-group.
!
ipc zone default
association 1
no shutdown
protocol sctp
local-port 9001
local-ip 10.0.1.54
local-ip 10.128.1.239
remote-port 9000
remote-ip 10.0.1.55
remote-ip 10.128.1.240
!
memory-size iomem 20
ip subnet-zero
!
ip domain-name cisco.com
ip name-server 10.0.0.6
!
!
! Note that for the Shared Point Code (ITP-group/Distributed MTP) configuration, the local
! point code value is 1.1.1, which is the same as the BTS OPC.
!
cs7 variant ANSI
cs7 point-code 1.1.1
!
controller E1 0/0
framing NO-CRC4
channel-group 0 timeslots 1
!
controller E1 0/1
framing NO-CRC4
channel-group 0 timeslots 1
!
controller E1 0/2
shutdown
!
controller E1 0/3
shutdown
!
interface FastEthernet0/0
ip address 10.0.1.54 255.255.0.0
speed auto
half-duplex
no clns route-cache
!
interface Serial0/0:0
description connect to link 0 of STP 1-1-20
no ip address
encapsulation mtp2
no clns route-cache
!
interface FastEthernet0/1
ip address 10.128.1.239 255.255.0.0
speed auto
half-duplex
no clns route-cache
!
interface Serial0/1:0
description connect to link 0 of STP 1-1-21
no ip address

```

```

encapsulation mtp2
no clns route-cache
!
!
! Unlike the Mated STP-Pair configuration, which defines a local-peer and mated-sg for
! redundancy, for the Distributed MTP3 feature Shared Point Code configuration, you
! define a cs7 group. This enables both ITPs in the ITP-group (or SGPs in the
! SG) to communicate with each other. In this configuration, you define the
! IP addresses and port values for both sides of the connection.
!
cs7 group grp-ITP1 9004
  local-ip 10.0.1.54
  local-ip 10.128.1.239
  peer grp-ITP2 9003
    remote-ip 10.0.1.55
    remote-ip 10.128.1.240
!
!
! Note here that when the linksets are defined, for redundancy, each linkset
! has links from each ITP in the ITP-group (or SGP in the SG).
!
cs7 linkset lset1chn 1.1.20
  link 0 grp-ITP1 Serial0/0:0
  link 1 grp-ITP2 Serial0/0:0
!
cs7 linkset lset2chn 1.1.21
  link 0 grp-ITP1 Serial0/1:0
  link 1 grp-ITP2 Serial0/1:0
!
! Note that unlike the Mated STP-Pair configuration, there are no low
! priority routes defined to the DPCs. This is because, in the ITP-group
! setup, the STPs view the combination of the two ITPs is as a single entity.
! The two SGPs form one SG. Therefore, there is no lower
! priority routes that travel across a C-link between the two
! ITPs like there is in the Mated STP-Pair configuration.
!
cs7 route-table system
  update route 1.1.30 255.255.255 linkset lset1chn priority 1
  update route 1.1.31 255.255.255 linkset lset2chn priority 1
  update route 1.1.30 255.255.255 linkset lset2chn priority 1
  update route 1.1.31 255.255.255 linkset lset1chn priority 1
  update route 1.1.40 255.255.255 linkset lset2chn priority 1
  update route 1.1.40 255.255.255 linkset lset1chn priority 1
!
! Routing to capability point codes of adjacent STPs
  update route 1.1.22 255.255.255 linkset lset1chn priority 1
  update route 1.1.22 255.255.255 linkset lset2chn priority 1
!
!
! The M3UA definition that declares local IP addresses and port
!
cs7 m3ua 2905
  local-ip 10.0.1.54
  local-ip 10.128.1.239
  keepalive 2000
!
!
! Here, as with all configurations, there are a minimum of two ASPs defined
! for each AS (one for the primary BTS node and one for the secondary BTS node).
! In reality, there will be at least one for each "user part" on the BTS10200.
! If you have a TCAP service going over SUA and ISUP traffic, you will
! have a total of at least four ASPs: primary ISUP, secondary ISUP, primary
! TCAP service, secondary TCAP service.

```

```

!
!2905 is the local port value. The remote IP addresses are the BTS IP addresses. They are
also obtained
! through the FQDN that is an SGA command line argument.
!
cs7 asp PriCaIsupAsp 11146 2905 m3ua
  remote-ip 10.0.1.5
  remote-ip 10.128.1.2
!
cs7 asp SecCaIsupAsp 11146 2905 m3ua
  remote-ip 10.0.1.6
  remote-ip 10.128.1.3
!
!
! The routing key is a very simple one. It has a routing context of 1 defined, the
! DPC (BTS OPC) of 1.1.1 defined, and a service indicator of ISUP defined.
! This means that all traffic coming from the SS7 service provider network that
! has a DPC of 1.1.1 and a service indicator of ISUP will be sent to either
! PrimaryBtsIsupAsp or SecondaryBtsIsupAsp (depending on which one is active).
!
! The traffic mode is always set to override (not loadshare), as with the current
implementation, only the override application server traffic mode is supported. In the
case of override-traffic mode, the reception of ASP active messages at the SGP causes the
redirection of all traffic for the AS to the ASP that sent the ASP active message.
!
!
! In BTS release 4.4 only, there is a work around that mandates the network-appearance to
! be configured with a value of 1. In Cisco BTS 10200 Softswitch release 4.5, this work
around is removed and network-appearance should not be provisioned on the Cisco ITP.
!
cs7 as CaIsupAs m3ua
  routing-key 1 1.1.1 si isup
  asp PriCaIsupAsp
  asp SecCaIsupAsp
  traffic-mode override
  network-appearance 1
!
!
! This is the SUA definition that declares local IP addresses and port numbers.
!
cs7 sua 14001
  local-ip 10.0.1.54
  local-ip 10.128.1.239
  keepalive 2000
!
!
! Here we are defining an ASP that will process AIN related traffic.
! 14001 is the local port number.
!
!
cs7 asp PriFsAinAsp 12205 14001 sua
  remote-ip 10.0.1.5
  remote-ip 10.128.1.2
!
cs7 asp SecFSainAsp 12205 14001 sua
  remote-ip 10.0.1.6
  remote-ip 10.128.1.3
!
!
! The following AS is defined for local number portability (LNP) related message flows.
! The routing context value is 4, the DPC (BTS OPC) is 1.1.1, the service indicator is
! SCCP and the subsystem number is 247. This means that any message received from the SS7

```

```

! service provider that has a DPC of 1.1.1, a service indicator of SCCP and an
! SSN of 247 will be sent to either PriFsAinAsp or SecFsAinAsp (depending
! on which one is active).
!
cs7 as FsAinLnpAs sua
  routing-key 4402 1.1.1 si sccp ssn 247
  asp PriFsAinAsp
  asp SecFsAinAsp
  traffic-mode override
  network-appearance 1

cs7 as FsAin800TAs sua
  routing-key 4401 1.1.1 si sccp ssn 254
  asp PriFsAinAsp
  asp SecFsAinAsp
  traffic-mode override
  network-appearance 1

cs7 as FsAin800AAs sua
  routing-key 4403 1.1.1 si sccp ssn 248
  asp PriFsAinAsp
  asp SecFsAinAsp
  traffic-mode override
  network-appearance 1

!
! Here we are defining an ASPs that will process FSPTC related traffic. 14001 is the local
! port number.
!

cs7 asp PriFsPtcAsp 12235 14001 sua
  remote-ip 10.0.1.5
  remote-ip 10.128.1.2
!
cs7 asp SecFsPtcAsp 12235 14001 sua
  remote-ip 10.0.1.6
  remote-ip 10.128.1.3
!
cs7 as FsPtcCnamAs sua
  routing-key 4404 1.1.1 si sccp ssn 232
  asp PriFsPtcAsp
  asp SecFsPtcAsp
  traffic-mode override

cs7 as FsPtcAcarAs sua
  routing-key 4405 1.1.1 si sccp ssn 251
  asp PriFsPtcAsp
  asp SecFsPtcAsp
  traffic-mode override

!

```

ITP2 Configuration

This is the second ITP in the ITP-Group (the second SGP in the SG). Please refer to the comments in the ITP1 Configuration section. The configuration in this section is similar to the ITP1 section, except for the ITP Group definition.

```

!
Current configuration : 4054 bytes
!
version 12.2

```

```

service timestamps debug datetime msec
service timestamps log datetime msec
no service password-encryption
!
hostname ITP2
!
boot-start-marker
boot system flash 2600/c2600-itp-mz.topsail_s_nightly_040915
boot-end-marker
!
redundancy inter-device
!
enable secret 5 $1$B6u2$gI4fFgj0Qo5XppDSWJDfI.
enable password cisco
!
ipc zone default
  association 1
  no shutdown
  protocol sctp
  local-port 9000
  local-ip 10.0.1.55
  local-ip 10.128.1.240
  remote-port 9001
  remote-ip 10.0.1.54
  remote-ip 10.128.1.239
!
memory-size iomem 10
ip subnet-zero
!
ip domain-name cisco.com
ip name-server 10.0.0.6
!
cs7 variant ANSI
cs7 point-code 1.1.1
!
controller E1 0/0
  framing NO-CRC4
  channel-group 0 timeslots 1
!
controller E1 0/1
  framing NO-CRC4
  channel-group 0 timeslots 1
!
controller E1 0/2
  shutdown
!
controller E1 0/3
  shutdown
!
interface FastEthernet0/0
  ip address 10.0.1.55 255.255.0.0
  speed auto
  half-duplex
  no cns route-cache
!
interface Serial0/0:0
  description connect to link 1 of STP 1-1-20
  no ip address
  encapsulation mtp2
  no cns route-cache
!
interface FastEthernet0/1
  ip address 10.128.1.240 255.255.0.0
  speed auto

```

```

half-duplex
no clns route-cache
!
interface Serial0/1:0
description connect to link 1 of STP 1-1-21
no ip address
encapsulation mtp2
no clns route-cache
!
cs7 group grp-ITP2 9003
local-ip 10.0.1.55
local-ip 10.128.1.240
peer grp-ITP1 9004
remote-ip 10.0.1.54
remote-ip 10.128.1.239
!
cs7 linkset lset1chn 1.1.20
link 0 grp-ITP1 Serial0/0:0
link 1 grp-ITP2 Serial0/0:0
!
cs7 linkset lset2chn 1.1.21
link 0 grp-ITP1 Serial0/1:0
link 1 grp-ITP2 Serial0/1:0
!
cs7 route-table system
update route 1.1.30 255.255.255 linkset lset1chn priority 1
update route 1.1.31 255.255.255 linkset lset2chn priority 1
update route 1.1.30 255.255.255 linkset lset2chn priority 1
update route 1.1.31 255.255.255 linkset lset1chn priority 1
update route 1.1.40 255.255.255 linkset lset2chn priority 1
update route 1.1.40 255.255.255 linkset lset1chn priority 1

! Routing to capability point codes of adjacent STPs
update route 1.1.22 255.255.255 linkset lset1chn priority 1
update route 1.1.22 255.255.255 linkset lset2chn priority 1

!
cs7 m3ua 2905
local-ip 10.0.1.55
local-ip 10.128.1.240
!
cs7 asp PriCaIsupAsp 11146 2905 m3ua
remote-ip 10.0.1.5
remote-ip 10.128.1.2
!
cs7 asp SecCaIsupAsp 11146 2905 m3ua
remote-ip 10.0.1.6
remote-ip 10.128.1.3
!
cs7 as CaIsupAs m3ua
routing-key 2 1.1.1 si isup
asp PriCaIsupAsp
asp SecCaIsupAsp
traffic-mode override
network-appearance 1
!
!
! The SUA definition that declares local IP addresses and port #
!
cs7 sua 14001
local-ip 10.0.1.54
local-ip 10.128.1.239
keepalive 2000
!

```

```

cs7 asp PriFsAinAsp 12205 14001 sua
  remote-ip 10.0.1.5
  remote-ip 10.128.1.2
!
cs7 asp SecFsAinAsp 12205 14001 sua
  remote-ip 10.0.1.6
  remote-ip 10.128.1.3
!
cs7 as FsAinLnpAs sua
  routing-key 4402 1.1.1 si sccp ssn 247
  asp PriFsAinAsp
  asp SecFsAinAsp
  traffic-mode override
  network-appearance 1

cs7 as FsAin800TAs sua
  routing-key 4401 1.1.1 si sccp ssn 254
  asp PriFsAinAsp
  asp SecFsAinAsp
  traffic-mode override
  network-appearance 1

!
cs7 as FsAin800AAs sua
  routing-key 4403 1.1.1 si sccp ssn 248
  asp PriFsAinAsp
  asp SecFsAinAsp
  traffic-mode override
  network-appearance 1
!
cs7 asp PriFsPtcAsp 12235 14001 sua
  remote-ip 10.0.1.5
  remote-ip 10.128.1.2
!
cs7 asp SecFsPtcAsp 12235 14001 sua
  remote-ip 10.0.1.6
  remote-ip 10.128.1.3
!
cs7 as FsPtcCnamAs sua
  routing-key 4404 1.1.1 si sccp ssn 232
  asp PriFsPtcAsp
  asp SecFsPtcAsp
  traffic-mode override

cs7 as FsPtcAcarAs sua
  routing-key 4405 1.1.1 si sccp ssn 251
  asp PriFsPtcAsp
  asp SecFsPtcAsp
  traffic-mode override

```

Cisco BTS 10200 Softswitch Provisioning for the Shared Point Code Configuration

The following example provisions the BTS 10200 for a basic Shared Point Code configuration:

```
#####
```

```

#
# CA configuration
#
add ca-config type=MGCP-INIT-TERMS;value=160;datatype=integer;
add ca-config type=MGCP-INIT-DURATION;value=5;datatype=integer;
add ca-config type=MGCP-ICMP-PING-RETRANSMIT-DURATION;value=5;datatype=integer;
add ca-config type=MGCP-ICMP-PING-RETRY-COUNT;value=5;datatype=integer;
add ca-config type=MGCP-MAX-UNREACH-COUNT;value=5;datatype=integer;
add ca-config type=MGCP-MAX-FAULT-COUNT;value=5;datatype=integer;
add ca-config type=MGCP-ADM-RESP-TIME;value=300;datatype=integer;
add ca-config type=MGCP-SIG-TOS-LOWDELAY;value=Y;datatype=boolean;
add ca-config type=MGCP-SIG-TOS-PRECEDENCE;value=1;datatype=integer;
add ca-config type=MGCP-SIG-TOS-RELIABILITY;value=Y;datatype=boolean;
add ca-config type=MGCP-SIG-TOS-THROUGHPUT;value=Y;datatype=boolean;
#
# CA & FS configuration
#
add call-agent id=CA146; tsap-addr-sidea=hrn11ca; mgw-monitoring-enabled=N;
add feature-server id=FSAIN205; tsap-addr-sidea=hrn11ca:11205; type=AIN;
add feature-server id=FSPTC235; tsap-addr-sidea=hrn11ca:11235; type=PTC;
#
# SIGTRAN components
#
add user-part-variant id=ANSISS7_GR317;
#
# Unlike the Mated STP-Pair solution that requires two SG definitions for each SG-grp,
# Shared Point Code (Basic Distributed MTP3) solution requires that only one SG be
associated
# with the SG-grp. This is because redundancy in the Shared Point Code solution is at the
SGP
# level (not the SG level).
#
add sg id=sg1; description=Signaling gateway 1;
add sg-grp id=sg-grp1; sg1-id=sg1; description=SG group 1;
#
# Note that there are two SGP definitions per SG. This is in contrast to the
# Mated STP-Pair solution that only allows one SGP per SG. It is at the SGP level that
# the Shared Point Code/Distributed MTP3 solution provides hardware and IP network
# redundancy.
#
add sgp id=sg1-sgp1 ; sg-id=sg1; description=SG process 1 for sg1;
add sgp id=sg1-sgp2 ; sg-id=sg1; description=SG process 2 for sg1;

add opc id=opc1; point-code=1-1-1; description=OPC; point-code-type=ANSI_CHINA;
add dpc id=dpc1; point-code=1-1-30; description=DPC 1; point-code-type=ANSI_CHINA;
add dpc id=dpc2; point-code=1-1-31; description=DPC 2; point-code-type=ANSI_CHINA;
#
# The ISUP routing keys
#
add routing-key id=rk1; opc-id=opc1; sg-grp-id=sg-grp1; si=ISUP; rc=1; platform-id=CA146;

add call-ctrl-route id=dpc1-route1; dpc-id=dpc1; routing-key-id=rk1; si=isup;
user-part-variant-id= ANSISS7_GR317
add call-ctrl-route id=dpc2-route1; dpc-id=dpc2; routing-key-id=rk1; si=isup;
user-part-variant-id= ANSISS7_GR317;
#
# SCTP configuration for M3UA (ISUP)
#
add sctp-assoc-profile id=sctp-prof;
#
# Note that the id used in the add sctp-assoc statement reflects the fact that
# this is the SCTP association for SGP1 of SG1.
#

```

```

add sctp-assoc id=sg1-sgp1-sctp; sgp-id=sg1-sgp1; sctp-assoc-profile-id=sctp-prof;
platform-id=CA146; remote-port=2905; remote-tsap-addr1=10.0.1.54;
remote-tsap-addr2=10.128.1.239; ip-tos-precedence=ROUTINE;

add sctp-assoc id=sg1-sgp2-sctp; sgp-id=sg1-sgp2; sctp-assoc-profile-id=sctp-prof;
platform-id=CA146; remote-port=2905; remote-tsap-addr1=10.0.1.55;
remote-tsap-addr2=10.128.1.240; ip-tos-precedence=ROUTINE;

#
# Dial plan profile with digit manipulation
#
add digman-profile id=pretrans;
add digman id=pretrans; rule=1; match-string=^*; replace-string=&; match-noa=any;
replace-noa=VSC;
add digman id=pretrans; rule=2; match-string=^#; replace-string=&; match-noa=any;
replace-noa=VSC;
add digman-profile id=ani_20;
add digman id=ani_20; rule=1; match-string=^20; replace-string=none;
add dial-plan-profile id=dp-1; nanp-dial-plan=Y; description=NA dial plan profile;
dnis-digman-id=pretrans; ani-digman-id=ani_20;
#
# SS7 trunk group configuration
#
add ss7-ansi-tg-profile ID=ansi-tg-prof;
add trunk-grp ID=1; call_agent_id=CA146; tg_type=SS7; direction=BOTH;
tg_profile_id=ansi-tg-prof; call-ctrl-route-id=dpc1-route1; dial-plan-id=dp-1;
description=TG to DPC 1; MGCP_PKG_TYPE=T;
add trunk-grp ID=2; call_agent_id=CA146; tg_type=SS7; direction=BOTH;
tg_profile_id=ansi-tg-prof; call-ctrl-route-id=dpc2-route1; dial-plan-id=dp-1;
description=TG to DPC 2; MGCP_PKG_TYPE=T;
#
# MGW configuration
#
add mgw-profile id=as5300-prof; vendor=Cisco; mgcp-hairpin-supp=n; MGCP_RSIPSTAR_SUPP=N;
MGCP_TERM_INIT_LEVEL=0; RBK_ON_CONN_SUPP=N; MGCP_VERSION=MGCP_1_0; mgcp-max2-retries=3;
fax-t38-camode-supp=Y; mgcp-keepalive-interval=60; mgcp-keepalive-retries=10;
mgcp-t-tran=400; mgcp-max1-retries=2; mgcp-t-longtran=5; mgcp-default-pkg=NONE;
MGCP_3WAY_HSHAKE_SUPP=N; mgw_type=AS5300; PC_MPTIME_SUPP=N;
MGCP_VERSION=MGCP_1_0; PC_MPTIME_SUPP=N;
add mgw id=va-5350-23; tsap-addr=va-5350-23.hrndevtest.cisco.com; call-agent-id=CA146;
mgw-profile-id=as5300-prof; type=TGW;
#
# SS7 terminations and trunks
#
add termination prefix=S3/DS1-4/; port-start=1; port-end=31; type=trunk;
mgw-id=va-5350-23;
add termination prefix=S3/DS1-5/; port-start=1; port-end=31; type=trunk;
mgw-id=va-5350-23;
add trunk cic-start=1; cic-end=31; tgn-id=1; mgw-id=va-5350-23;
termination-prefix=S3/DS1-4/; termination-port-start=1; termination-port-end=31;
add trunk cic-start=1; cic-end=31; tgn-id=2; mgw-id=va-5350-23;
termination-prefix=S3/DS1-5/; termination-port-start=1; termination-port-end=31;
#
# SS7 routes, route guides and destinations
#
add route id=dpc1-route; tg_selection=RR; tgn1_id=1;
add route id=dpc2-route; tg_selection=RR; tgn1_id=2;
add route-guide id=dpc1-rg; policy-type=ROUTE; policy-id=dpc1-route;
add route-guide id=dpc2-rg; policy-type=ROUTE; policy-id=dpc2-route;
add destination dest-id=dpc1-dest; call-type=LOCAL; route-type=ROUTE;
route-guide-id=dpc1-rg;
add destination dest-id=dpc2-dest; call-type=LOCAL; route-type=ROUTE;
route-guide-id=dpc2-rg;

```

```

#
#   TCAP/SUA provisioning for FSAIN, FSPTC
#
add sctp-assoc id=sg1-sgp1-sctp-ain; sgp-id=sg1-sgp1; sctp-assoc-profile-id=sctp-prof;
platform-id=FSAIN205; remote-port=14001; remote-tsap-addr1=10.0.1.54;
remote-tsap-addr2=10.128.1.239; ip-tos-precedence=ROUTINE;

add sctp-assoc id=sg1-sgp2-sctp-ain; sgp-id=sg2-sgp1; sctp-assoc-profile-id=sctp-prof;
platform-id=FSAIN205; remote-port=14001; remote-tsap-addr1=10.0.1.55;
remote-tsap-addr2=10.128.1.240; ip-tos-precedence=ROUTINE;

add sctp-assoc id=sg1-sgp1-sctp-ptc; sgp-id=sg1-sgp1; sctp-assoc-profile-id=sctp-prof;
platform-id=FSPTC235; remote-port=14001; remote-tsap-addr1=10.0.1.54;
remote-tsap-addr2=10.128.1.239; ip-tos-precedence=ROUTINE;

add sctp-assoc id=sg1-sgp2-sctp-ptc; sgp-id=sg2-sgp1; sctp-assoc-profile-id=sctp-prof;
platform-id=FSPTC235; remote-port=14001; remote-tsap-addr1=10.0.1.55;
remote-tsap-addr2=10.128.1.240; ip-tos-precedence=ROUTINE;

add sccp-nw id=1;NET_IND=NATIONAL;SUB_SVC=NATIONAL;HOP_COUNT=3;

add subsystem-profile id=SS_LNP; platform-id=FSAIN205; description=LNP subsystem;
add subsystem-profile id=SS_800A; platform-id=FSAIN205; description=AIN 800 subsystem;
add subsystem-profile id=SS_800T; platform-id=FSAIN205; description=IN1 800 subsystem;
add subsystem-profile id=SS_CNAM; platform-id=FSAIN205; description=CNAM subsystem;
add subsystem-profile id=SS_ACAR; platform-id=FSPTC235; description=ACAR subsystem;

add subsystem id=SS_LNP; opc-id=opc1; local-ssn=247; remote-ssn=247; sccp-nw-id=1;
SCCP_VERSION=ANS92; TCAP_VERSION=ANS92; APPLICATION_VERSION=AIN01;
add subsystem id=SS_800A; opc-id=opc1; local-ssn=248; remote-ssn=248; sccp-nw-id=1;
SCCP_VERSION=ANS92; TCAP_VERSION=ANS92; APPLICATION_VERSION=AIN01;
add subsystem id=SS_CNAM; opc-id=opc1; local-ssn=232; remote-ssn=232; sccp-nw-id=1;
SCCP_VERSION=ANS92; TCAP_VERSION=ANS92; APPLICATION_VERSION=IN1;
add subsystem id=SS_800T; opc-id=opc1; local-ssn=254; remote-ssn=254; sccp-nw-id=1;
SCCP_VERSION=ANS92; TCAP_VERSION=ANS92; APPLICATION_VERSION=IN1;
add subsystem id=SS_ACAR; opc-id=opc1; local-ssn=251; remote-ssn=251; sccp-nw-id=1;
SCCP_VERSION=ANS92; TCAP_VERSION=ANS92; APPLICATION_VERSION=IN1;

add routing-key id=rk_lnp; opc-id=opc1; sg-grp-id=sg_grp1; si=SCCP; rc=4402;
PLATFORM_ID=FSAIN205; ssn-id=SS_LNP;
add routing-key id=rk_800a; opc-id=opc1; sg-grp-id=sg_grp1; si=SCCP; rc=4403;
PLATFORM_ID=FSAIN205; ssn-id=SS_800A;
add routing-key id=rk_cnam; opc-id=opc1; sg-grp-id=sg_grp1; si=SCCP; rc=4404;
PLATFORM_ID=FSAIN205; ssn-id=SS_CNAM;
add routing-key id=rk_800t; opc-id=opc1; sg-grp-id=sg_grp1; si=SCCP; rc=4401;
PLATFORM_ID=FSAIN205; ssn-id=SS_800T;
add routing-key id=rk_acar; opc-id=opc1; sg-grp-id=sg_grp1; si=SCCP; rc=4405;
PLATFORM_ID=FSPTC235; ssn-id=SS_ACAR;

#
# Provisioned DPC is the STP capability point code (alias point code)
#
add dpc id=stp_cap_pc; point-code=1-1-22; point-code-type=ANSI_CHINA;
description=Capability Point Code of STPs

add feature fname=LNP; feature-server-id=FSAIN205; description=Local number portability;
tdp1=COLLECTED_INFORMATION; tid1=LNP_TRIGGER; ttype1=R;

add ported-office-code digit-string=301-612; in-call-agent=n;

add CA-Config type=DEFAULT-LNP-SLHR-ID; datatype=string; value=slhr_lnp;

```

```

add slhr-profile id=slhr_800t; description=Service Logic Host Routing Table for IN1 800
Service;
add slhr-profile id=slhr_lnp; description=Service Logic Host Routing Table for AIN LNP
Service;
add slhr-profile id=slhr_800a; description=Service Logic Host Routing Table for AIN 800
Service;
add slhr-profile id=slhr_cnam; description=Service Logic Host Routing Table for IN1 CNAM
Service;
add slhr-profile id=slhr_acar; description=Service Logic Host Routing Table for ACAR
Service;

add slhr id=slhr_800t; opc-id=opc1; dpc-id=stp_cap_pc; ssn-id=SS_800T; gtt-req=Y; tt=254;
GTT_ADDR_TYPE=CDPN; GTT_ADDR=3;
add slhr id=slhr_lnp; opc-id=opc1; dpc-id=stp_cap_pc; ssn-id=SS_LNP; gtt-req=Y; tt=11;
GTT_ADDR_TYPE=CDPN; GTT_ADDR=3;
add slhr id=slhr_800a; opc-id=opc1; dpc-id=stp_cap_pc; ssn-id=SS_800A; gtt-req=Y; tt=8;
GTT_ADDR_TYPE=CDPN; GTT_ADDR=3;
add slhr id=slhr_cnam; opc-id=opc1; dpc-id=stp_cap_pc; ssn-id=SS_CNAM; gtt-req=Y; tt=5;
GTT_ADDR_TYPE=CLGN; GTT_ADDR=3;
add slhr id=slhr_acar; opc-id=opc1; dpc-id=stp_cap_pc; ssn-id=SS_ACAR; gtt-req=Y; tt=251;
GTT_ADDR_TYPE=CDPN; GTT_ADDR=10;

add sccp-route opc-id=opc1; dpc-id=stp_cap_pc; ssn-id=SS_800T; rk-id=rk_800t;
add sccp-route opc-id=opc1; dpc-id=stp_cap_pc; ssn-id=SS_800A; rk-id=rk_800a;
add sccp-route opc-id=opc1; dpc-id=stp_cap_pc; ssn-id=SS_LNP; rk-id=rk_lnp;
add sccp-route opc-id=opc1; dpc-id=stp_cap_pc; ssn-id=SS_CNAM; rk-id=rk_cnam;
add sccp-route opc-id=opc1; dpc-id=stp_cap_pc; ssn-id=SS_ACAR; rk-id=rk_acar;

add sccp-route SSN_ID=SS_ACAR; OPC_ID=opc1; DPC_ID=dpc1; RK_ID=rk_acar
add sccp-route SSN_ID=SS_ACAR; OPC_ID=opc1; DPC_ID=dpc2; RK_ID=rk_acar

add pop ID=50901; STATE=tx; COUNTRY=US; TIMEZONE=CDT; LOCAL_7D_DIALING=Y; ITP=N;
ZERO_MINUS=LEC; BLOCK_EAWOPIC=Y; CNAM_OPTION=EXT_LIDB; PIC2_REQD=N; MY_LRN=4692559999;
TREAT_IMS_ANONYMOUS=N; OPC_ID=opc1; ZERO_PLUS_LOCAL=N

#
# Control network entities in-service for ANSI SS7
#
control trunk-grp id=1; mode=forced; target-state=ins;
control trunk-grp id=2; mode=forced; target-state=ins;
equip trunk-termination tgn-id=1; cic=all;
equip trunk-termination tgn-id=2; cic=all;
control trunk-termination tgn-id=1; cic=all; target-state=INS; mode=FORCED;
control trunk-termination tgn-id=2; cic=all; target-state=INS; mode=FORCED;
control sctp-assoc id=sg1-sgp1-sctp; mode=forced; target-state=INS;
control sctp-assoc id=sg1-sgp2-sctp; mode=forced; target-state=INS;
control sctp-assoc id=sg1-sgp1-sctp-ain; mode=forced; target-state=INS;
control sctp-assoc id=sg1-sgp2-sctp-ain; mode=forced; target-state=INS;
control sctp-assoc id=sg1-sgp1-sctp-ptc; mode=forced; target-state=INS;
control sctp-assoc id=sg1-sgp2-sctp-ptc; mode=forced; target-state=INS;
control subsystem id=SS_800T; opc-id=opc; target-state=UIS; mode=FORCED;
control subsystem id=SS_LNP; opc-id=opc; target-state=UIS; mode=FORCED;
control subsystem id=SS_800A; opc-id=opc; target-state=UIS; mode=FORCED;
control subsystem id=SS_CNAM; opc-id=opc; target-state=UIS; mode=FORCED;
control subsystem id=SS_ACAR; opc-id=opc; target-state=UIS; mode=FORCED;

#
# Status commands
#
#status trunk-grp id=1;
#status trunk-grp id=2;

```

```
#status trunk-termination tgn-id=1; cic=all;
#status trunk-termination tgn-id=2; cic=all;
#status sctp-assoc id=sg1-sgp1-sctp;
#status sctp-assoc id=sg1-sgp2-sctp;
#status sctp-assoc id=sg1-sgp1-sctp;
#status sctp-assoc id=sg1-sgp2-sctp;
#status sctp-assoc id=sg1-sgp1-sctp-ain;
#status sctp-assoc id=sg1-sgp2-sctp-ain;
#status sctp-assoc id=sg1-sgp1-sctp-ptc;
#status sctp-assoc id=sg1-sgp2-sctp-ptc;
#status subsystem id=SS_800T; opc-id=opc;
#status subsystem id=SS_LNP; opc-id=opc;
#status subsystem id=SS_800A; opc-id=opc;
#status subsystem id=SS_CNAM; opc-id=opc;
#status subsystem id=SS_ACAR; opc-id=opc;
```

NSO Configuration Examples

D Link for ISUP with ASP Loading Sharing Configuration

Step 1 Add the Signaling Gateways with internal redundancy mode set to SSO-NSO.

```
add sg id=sgw100; internal_redundancy_mode=SSO-NSO;description=SS7 Signaling Gateway ANSI
testing;priority=1;
add sg id=sgw110; internal_redundancy_mode=SSO-NSO;description=SS7 Signaling Gateway ANSI
testing;priority=1;
```

Step 2 Add the Signaling Gateway Group for STP (Mated STP) mode.

```
add sg-grp id=sg-grp100; sg1-id=sgw100;sg2-id=sgw110; sg-grp-mode=Mated_STP;description=SG
Group for ANSI testing;
```

Step 3 Add 2 Signaling Gateway Process (SGP) for each Signaling Gateway.

```
add sgp id=sgw100-sgp1; sg-id=sgw100; description=SGP on ITP va-7507-3;
add sgp id=sgw100-sgp2; sg-id=sgw100; description=SGP on ITP va-7507-3;
add sgp id=sgw110-sgp1; sg-id=sgw110; description=SGP on ITP va-7507-6;
add sgp id=sgw110-sgp2; sg-id=sgw110; description=SGP on ITP va-7507-6;
```

Step 4 Add the OPC and ISUP DPCs.

```
add opc id=opc1; point-code=250-250-3; point-code-type=ANSI_CHINA;description= Network
Point Code 1;
add dpc id=hollyville; point-code=250-248-4; point-code-type=ANSI_CHINA; description=ANSI
SS7 network DPC;
add dpc id=havenville; point-code=250-248-6; point-code-type=ANSI_CHINA; description=ANSI
SS7 network DPC;
```

Step 5 Add the SCTP association profile.

```
add sctp-assoc-profile id=sctp_pf100;
```

Step 6 Add the SCTP associations to each Signaling Gateway.

```
add sctp-assoc id=CA-assoc1; sgp-id=sgw100-sgp1; sctp-assoc-profile-id=sctp_pf100;
platform-id=CA146; remote-port=2905; REMOTE_TSAP_ADDR1=10.0.1.230;
add sctp-assoc id=CA-assoc2; sgp-id=sgw100-sgp2; sctp-assoc-profile-id=sctp_pf100;
platform-id=CA146; remote-port=2907; REMOTE_TSAP_ADDR1=10.128.7.8;
add sctp-assoc id=CA-assoc3; sgp-id=sgw110-sgp1; sctp-assoc-profile-id=sctp_pf100;
platform-id=CA146; remote-port=2905; remote-tsap-addr1=10.0.5.216;
add sctp-assoc id=CA-assoc4; sgp-id=sgw110-sgp2; sctp-assoc-profile-id=sctp_pf100;
platform-id=CA146; remote-port=2907; remote-tsap-addr1=10.128.2.7;
```

Step 7 Add the ISUP routing key.

```
add routing-key id=NewMatedSG-rk; opc-id=opc1; sg-grp-id=sg-grp100; si=ISUP;
platform-id=CA146; rc=60; description=Dual processor Signaling Gateway;
```

Step 8 Add call control routes for each ISUP DPC.

```
add call-ctrl-route id=holly-ccr; routing-key-id=NewMatedSG-rk; dpc-id=hollyville;
user-part-variant-id=ANSISS7_GR317; si=ISUP; description=Call Control Route for ANSI ISUP
DPC;
add call-ctrl-route id=haven-ccr; routing-key-id=NewMatedSG-rk; dpc-id=havenville;
user-part-variant-id=ANSISS7_GR317; si=ISUP; description=Call Control Route for ANSI ISUP
DPC;
```

Step 9 Add the SS7 trunk group, trunks, routing to the SS7 network destination and dial plan, and equip the trunk group terminations according to your network setup, if you have not already done so.**Step 10** Control CA SCTP-assoc INS.

```
control sctp-assoc id=CA-assoc1; mode=forced; target-state=ins;
control sctp-assoc id=CA-assoc2; mode=forced; target-state=ins;
control sctp-assoc id=CA-assoc3; mode=forced; target-state=ins;
```

D Link for TCAP with ASP Load Sharing Configuration

Step 1 Add the Signaling Gateways with internal redundancy mode set to SSO-NSO.

```
add sg id=sgw100; internal_redundancy_mode=SSO-NSO; description=SS7 Signaling Gateway ANSI
testing; priority=1;
add sg id=sgw110; internal_redundancy_mode=SSO-NSO; description=SS7 Signaling Gateway ANSI
testing; priority=1;
```

Step 2 Add the Signaling Gateway Group for STP (Mated STP) mode.

```
add sg-grp id=sg-grp100; sg1-id=sgw100; sg2-id=sgw110; sg-grp-mode=Mated_STP; description=SG
Group for ANSI testing;
```

Step 3 Add 2 Signaling Gateway Process (SGPs) for each Signaling Gateway.

```

add sgp id=sgw100-sgp1; sg-id=sgw100; description=SGP on ITP va-7507-3;
add sgp id=sgw100-sgp2; sg-id=sgw100; description=SGP on ITP va-7507-3;
add sgp id=sgw110-sgp1; sg-id=sgw110; description=SGP on ITP va-7507-6;
add sgp id=sgw110-sgp2; sg-id=sgw110; description=SGP on ITP va-7507-6;

```

Step 4 Add OPC andTCAP DPCs.

```

add opc id=opc1; point-code=250-250-3; point-code-type=ANSI_CHINA;description= Network
Point Code 1;
add dpc id=cap_dpcl;point-code=1-101-0;point-code-type=ANSI_CHINA;description=Capability
Point Code for remote STP with GTT;
add dpc id=office2; point-code=250-250-3; description= Destination point code for IMT;

```

Step 5 Add the FSAIN and FSPTC feature server SCTP associations for LNP, 800, CNAM, andAC/AR services.

```

add sctp-assoc id=FSAIN-assoc1; sgp-id=sgw100-sgp1;
sctp-assoc-profile-id=sctp_pf100;platform-id=FSAIN205;
remote-port=14001;REMOTE_TSAP_ADDR1=10.0.1.230;
add sctp-assoc id=FSAIN-assoc2; sgp-id=sgw100-sgp2; sctp-assoc-profile-id=sctp_pf100;
platform-id=FSAIN205; remote-port=14002; REMOTE_TSAP_ADDR1=10.128.7.8;
add sctp-assoc id=FSAIN-assoc3; sgp-id=sgw100-sgp1;
sctp-assoc-profile-id=sctp_pf100;platform-id=FSPTC235;
remote-port=14001;REMOTE_TSAP_ADDR1=10.0.1.230;
add sctp-assoc id=FSAIN-assoc4; sgp-id=sgw100-sgp2; sctp-assoc-profile-id=sctp_pf100;
platform-id=FSPTC235; remote-port=14002; REMOTE_TSAP_ADDR1=10.128.7.8;
add sctp-assoc id=FSPTC-assoc1; sgp-id=sgw110-sgp1; sctp-assoc-profile-id=sctp_pf100;
platform-id=FSAIN205; remote-port=14001;REMOTE_TSAP_ADDR1=10.0.5.216;
add sctp-assoc id=FSPTC-assoc2; sgp-id=sgw110-sgp2; sctp-assoc-profile-id=sctp_pf100;
platform-id=FSAIN205;remote-port=14002;REMOTE_TSAP_ADDR1=10.128.2.7;
add sctp-assoc id=FSPTC-assoc3; sgp-id=sgw110-sgp1;
sctp-assoc-profile-id=sctp_pf100;platform-id=FSPTC235;
remote-port=14001;REMOTE_TSAP_ADDR1=10.0.5.216;
add sctp-assoc id=FSPTC-assoc4; sgp-id=sgw110-sgp2; sctp-assoc-profile-id=sctp_pf100;
platform-id=FSPTC235; remote-port=14002; REMOTE_TSAP_ADDR1=10.128.2.7;

```

Step 6 Add the LNP, CNAM, and 800 features.

```

add feature fname=LNP; feature-server-id=FSAIN205; description=Local number portability;
tdp1=COLLECTED_INFORMATION; tid1=LNP_TRIGGER; ttype1=R;
add feature fname=8XX; tdp1=COLLECTED_INFORMATION; tid1=SPECIFIC_DIGIT_STRING; ttype1=R;
description=Toll Free Number; feature_server_id=FSAIN205;
add feature fname=CNAM;tdp1=FACILITY_SELECTED_AND_AVAILABLE;
tid1=TERMINATION_RESOURCE_AVAILABLE; ttype1=R; description=Calling Name;
feature_server_id=FSPTC235;
add feature fname=AC; fname1=AC_ACT; fname2=AC_DEACT; feature_server_id=FSPTC235;
add feature fname=AR; fname1=AR_ACT; fname2=AR_DEACT; feature_server_id=FSPTC235;

```

Step 7 Add the SCCP network for TCAP services.

```

add sccp-nw id=6;net-ind=NATIONAL;sub-svc=NATIONAL;hop-count=3;

```

Step 8 Addthe SSN profile.

```

add subsystem-grp id=SSN_LNP1;platform-id=FSAIN205;tcap-version=ANS92; description=SS grp
profile for LNP svc;
add subsystem-grp id=SSN_AIN_800_1; platform-id=FSAIN205;tcap-version=ANS92;
description=SSN grp profile for 800 svc;
add subsystem-grp id=SSN_CNAM1; platform-id=FSPTC235;tcap-version=ANS92; description=SSN
grp profile for CNAM svc;
add subsystem-grp id=SSN_ACAR1; platform-id=FSPTC235;tcap-version=ANS92; description=SSN
grp profile for AC/AR svc;

```

Step 9 Add a subsystem.

```
add subsystem id=SSN_LNP1; opc-id=opc1; local-ssn=247;remote-ssn=247;
sccp-nw-id=6;sccp-version=ANS92; application-version=AIN01;
add subsystem id=SSN_AIN_800_1; opc-id=opc1; local-ssn=248;remote-ssn=248;
sccp-nw-id=6;sccp-version=ANS92; application-version=AIN01;
add subsystem id=SSN_CNAM1; opc-id=opc1; local-ssn=232;remote-ssn=232; sccp-nw-id=6;
sccp-version=ANS92; application-version=IN1;
add subsystem id=SSN_ACAR1; opc-id=opc1;
local-ssn=251;remote-ssn=251;sccp-nw-id=6;sccp-version=ANS92;APPLICATION_VERSION=IN1;
```

Step 10 Add a routing key for FSPTC and FSAIN.

```
add routing-key id=NewMatedSG-rk1; opc-id=opc1;
sg-grp-id=sg-grp100;si=sccp;subsystem-grp-id=SSN_LNP1;platform-id=FSAIN205; rc=161;
description=Routing Key for SUA User Adaptation layer;
add routing-key id=NewMatedSG-rk2; opc-id=opc1; sg-grp-id=sg-grp100;
si=sccp;subsystem-grp-id=SSN_AIN_800_1;platform-id=FSAIN205; rc=162; description=Routing
Key for SUA User Adaptation layer in FSAIN205;
add routing-key id=NewMatedSG-rk3; opc-id=opc1; sg-grp-id=sg-grp100;
si=sccp;subsystem-grp-id=SSN_CNAM1;platform-id=FSPTC235; rc=163; description=Routing Key
for SUA User Adaptation layer in FSPTC235;
add routing-key id=NewMatedSG-rk4; opc-id=opc1;
sg-grp-id=sg-grp100;si=sccp;subsystem-grp-id=SSN_ACAR1;platform-id=FSPTC235;
rc=164;description=Routing Key for SUA User Adaptation layer in FSPTC235;
```

Step 11 Add SCCP routes for LNP, CNAM, 800, and ACR.

```
add sccp-route opc-id=opc1; dpc-id=cap_dpc1; rk-id=NewMatedSG-rk1;
subsystem-grp-id=SSN_LNP1;description=SCCP route for FSAIN LNP service;
add sccp-route opc-id=opc1; dpc-id=cap_dpc1; rk-id=NewMatedSG-rk2;
subsystem-grp-id=SSN_AIN_800_1;description=SCCP route for 800 service in FSAIN;
add sccp-route opc-id=opc1;dpc-id=cap_dpc1;rk-id=NewMatedSG-rk3;
subsystem-grp-id=SSN_CNAM1;description=SCCP route for FSPTC CNAM service;
add sccp-route opc-id=opc1;dpc-id=office2;rk-id=NewMatedSG-rk4;
subsystem-grp-id=SSN_ACAR1;description=SCCP route for FSPTC ACAR service;
add call-ctrl-route id=office2-ccr;routing-key-id=NewMatedSG-rk;dpc-id=office2;
user-part-variant-id=ANSISS7_GR317; si=ISUP;description=Call Control Route for Office2
destination;
```

Step 12 Add an SS7 trunk group for AC/AR service, the Call Agent configuration for TCAP services, the SLHR profile, and the SLHR, and configure the 800 dialing and ported office codes for your network setup.**Step 13** Control FSAIN SCTP association into service.

```
control sctp-assoc id=FSAIN-assoc1;mode=forced;target-state=ins;
control sctp-assoc id=FSAIN-assoc2;mode=forced;target-state=ins;
control sctp-assoc id=FSAIN-assoc3;mode=forced;target-state=ins;
control sctp-assoc id=FSAIN-assoc4;mode=forced;target-state=ins;
```

Step 14 Control the FSPTC SCTP association into service.

```
control sctp-assoc id=FSPTC-assoc1;mode=forced;target-state=ins;
control sctp-assoc id=FSPTC-assoc2;mode=forced;target-state=ins;
control sctp-assoc id=FSPTC-assoc3;mode=forced;target-state=ins;
control sctp-assoc id=FSPTC-assoc4;mode=forced;target-state=ins;
```

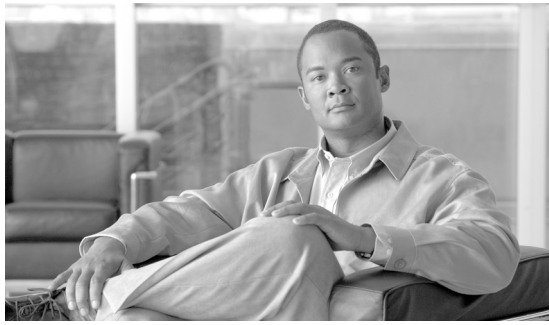
CHAPTER 3

Customer Profiles

Revised: May 7, 2007, OL-12779-02

This chapter describes various configurations and combinations of the Cisco BTS 10200 Softswitch and the Cisco ITP that are built on top of the basic Shared Point Code and Mated STP-Pair configurations documented in [Chapter 1, “SS7 Basic Configurations,”](#) to form the following customer profiles:

- [Multiple Cisco BTS 10200 Softswitch Nodes per ITP](#)
- [Multiple OPCs on the Cisco BTS 10200 Softswitch](#)
- [Multiple Cisco BTS 10200 Softswitch Nodes Sharing the Same OPC](#)
- [Geographically Separated Mated STP Pair with SG Priority Routing](#)

Multiple Cisco BTS 10200 Softswitch Nodes per ITP

This profile, illustrated in [Figure 3-1](#), is recommended for a customer who is setting up an all-IP telephony network based on BTS 10200es and has a long-term plan for network expansion. Each BTS has only one OPC, and this profile is appropriate when there is a requirement for high capacity traffic to each OPC.

A pair of high capacity Cisco 73XX or 7507 series ITP nodes are required to provide the necessary throughput. The topology between ITPs and STPs forms a typical SS7 STP quad. GTT is supported on the Cisco ITP.



Note

This profile is only available when connecting to the SS7 network via D-links. Therefore, a mated STP pair must be used.

Figure 3-1 Multiple Cisco BTS 10200 Softswitches per ITP

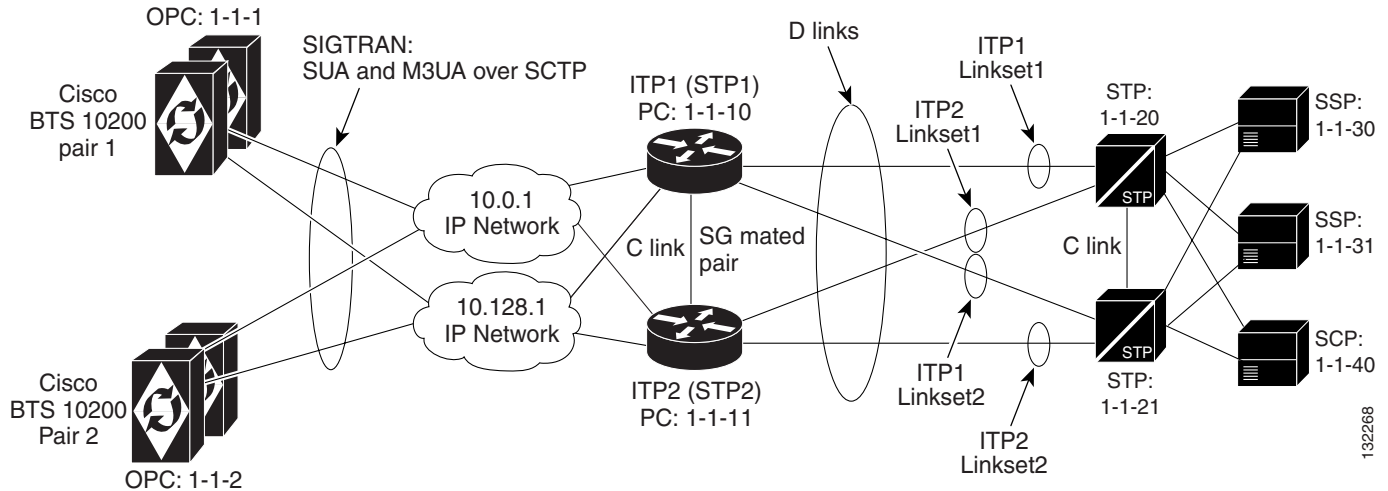

Cisco ITP Configuration Example

The Cisco ITP configuration information for this customer profile is similar to the basic Mated STP-Pair configuration described in [Chapter 2, “Provisioning Basic SS7 Configurations.”](#) However, in this profile, extra ASP configuration information is necessary to communicate with the second BTS 10200. There is also extra information in the AS configuration section for routing to each of the BTS nodes based on DPC (BTS OPC value).

The following example provisions ASP and AS configuration elements for ITP1:

```

!
! ITP1 Configuration -
! It is important to note that ITP2 will have the same ASP and AS configuration
! information
! that is shown below for ITP1.
!
! ASP configuration for BTS1 Active and Standby Nodes
! For ISUP - M3UA
cs7 asp PRI_ISUP_BTS1 11146 2905 m3ua
  remote-ip 10.0.1.5
  remote-ip 10.128.1.2

cs7 asp SEC_ISUP_BTS1 11146 2905 m3ua
  remote-ip 10.0.1.6
  remote-ip 10.128.1.3

! For TCAP/AIN - SUA
cs7 asp PRI_AIN_BTS1 12205 14001 sua
  remote-ip 10.0.1.5
  remote-ip 10.128.1.2
!
cs7 asp SEC_AIN_BTS1 12205 14001 sua
  remote-ip 10.0.1.6
  remote-ip 10.128.1.3

! For TCAP/PTC - SUA
cs7 asp PRI_PTC_BTS1 12235 14001 sua
  remote-ip 10.0.1.5

```

```

remote-ip 10.128.1.2
!
cs7 asp SEC_PTC_BTS1 12235 14001 sua
remote-ip 10.0.1.6
remote-ip 10.128.1.3

! AS configuration for BTS1
!
! Note: In the following configuration the routing context entries are as follows:
! routing context = 1, DPC(BTS OPC)=1.1.1 service indicator=ISUP
!
! Configuring network-appearance 1 is required for release 4.4 but must not be used
! in release 4.5 and beyond.

cs7 as ISUP_BTS1 m3ua
routing-key 1 1.1.1 si isup
asp PRI_ISUP_BTS1
asp SEC_ISUP_BTS1
traffic-mode override
network-appearance 1

cs7 as LNP_BTS1 sua
routing-key 4402 1.1.1 si sccp ssn 247
asp PRI_AIN_BTS1
asp SEC_AIN_BTS1
traffic-mode override

cs7 as 800T_BTS1 sua
routing-key 4401 1.1.1 si sccp ssn 254
asp PRI_AIN_BTS1
asp SEC_AIN_BTS1
traffic-mode override
!
cs7 as 800A_BTS1 sua
routing-key 4403 1.1.1 si sccp ssn 248
asp PRI_AIN_BTS1
asp SEC_AIN_BTS1
traffic-mode override
!
cs7 as CNAM_BTS1 sua
routing-key 4404 1.1.1 si sccp ssn 232
asp PRI_PTC_BTS1
asp SEC_PTC_BTS1
traffic-mode override
!
cs7 as ACAR_BTS1 sua
routing-key 4405 1.1.1 si sccp ssn 251
asp PRI_PTC_BTS1
asp SEC_PTC_BTS1
traffic-mode override
!
! ASP configuration for BTS2 active and standby modes
! For ISUP - M3UA
cs7 asp PRI_ISUP_BTS2 11146 2905 m3ua
remote-ip 10.0.1.7
remote-ip 10.128.1.4

cs7 asp SEC_ISUP_BTS2 11146 2905 m3ua
remote-ip 10.0.1.8
remote-ip 10.128.1.5

! For TCAP/AIN - SUA

```

```

cs7 asp PRI_AIN_BTS2 12205 14001 sua
  remote-ip 10.0.1.7
  remote-ip 10.128.1.4
!
cs7 asp SEC_AIN_BTS2 12205 14001 sua
  remote-ip 10.0.1.8
  remote-ip 10.128.1.5
!
! For TCAP/PTC - SUA
cs7 asp PRI_PTC_BTS2 12235 14001 sua
  remote-ip 10.0.1.5
  remote-ip 10.128.1.4
!
cs7 asp SEC_PTC_BTS2 12235 14001 sua
  remote-ip 10.0.1.6
  remote-ip 10.128.1.5

! AS configuration for BTS2
! Note that the DPC value changes to 1.1.2 for sending messages to BTS2
cs7 as ISUP_BTS2 m3ua
  routing-key 2 1.1.2 si isup
  asp PRI_ISUP_BTS2
  asp SEC_ISUP_BTS2
  traffic-mode override
  network-appearance 1
!
cs7 as LNP_BTS2 sua
  routing-key 4502 1.1.1 si sccp ssn 247
  asp PRI_AIN_BTS2
  asp SEC_AIN_BTS2
  traffic-mode override

cs7 as 800T_BTS2 sua
  routing-key 4501 1.1.1 si sccp ssn 254
  asp PRI_AIN_BTS2
  asp SEC_AIN_BTS2
  traffic-mode override
!
cs7 as 800A_BTS2 sua
  routing-key 4503 1.1.1 si sccp ssn 248
  asp PRI_AIN_BTS2
  asp SEC_AIN_BTS2
  traffic-mode override
!
cs7 as CNAM_BTS2 sua
  routing-key 4504 1.1.1 si sccp ssn 232
  asp PRI_PTC_BTS2
  asp SEC_PTC_BTS2
  traffic-mode override
!
cs7 as ACAR_BTS2 sua
  routing-key 4505 1.1.1 si sccp ssn 251
  asp PRI_PTC_BTS2
  asp SEC_PTC_BTS2
  traffic-mode override
!

```

Cisco BTS 10200 Softswitch Configuration Example

Provisioning the BTS 10200 for this profile is essentially the same as the basic Mated STP-Pair profile given in [Chapter 1, “SS7 Basic Configurations.”](#) However, the following provisioning script is necessary for the secondary BTS:

```
#####
#
# CA Configuration
#
#####

add ca-config type=MGCP-INIT-TERMS;value=160;datatype=integer;
add ca-config type=MGCP-INIT-DURATION;value=5;datatype=integer;
add ca-config type=MGCP-ICMP-PING-RETRANSMIT-DURATION;value=5;datatype=integer;
add ca-config type=MGCP-ICMP-PING-RETRY-COUNT;value=5;datatype=integer;
add ca-config type=MGCP-MAX-UNREACH-COUNT;value=5;datatype=integer;
add ca-config type=MGCP-MAX-FAULT-COUNT;value=5;datatype=integer;
add ca-config type=MGCP-ADM-RESP-TIME;value=300;datatype=integer;
add ca-config type=MGCP-SIG-TOS-LOWDELAY;value=Y;datatype=boolean;
add ca-config type=MGCP-SIG-TOS-PRECEDENCE;value=1;datatype=integer;
add ca-config type=MGCP-SIG-TOS-RELIABILITY;value=Y;datatype=boolean;
add ca-config type=MGCP-SIG-TOS-THROUGHPUT;value=Y;datatype=boolean;
#
# CA & FS
#
# Note that the ids: CA147 and FSAIN206 are different than on BTS1.
#
add call-agent id=CA147; tsap-addr-sidea=hrn11ca; mgw-monitoring-enabled=N;
add feature-server id=FSAIN206; tsap-addr-sidea=hrn11ca:11205; type=AIN;

#
# SIGTRAN components
#
add user-part-variant id=ANSISS7_GR317;

add sg id=sg1; description=Signaling gateway 1;
add sg id=sg2; description=Signaling gateway 2;

add sg-grp id=sg-grp1; sg1-id=sg1; sg2-id=sg2 description=SG group 1;

add sgp id=sg1-sgp1 ; sg-id=sg1; description=SG process 1 for sg1;
add sgp id=sg2-sgp1 ; sg-id=sg2; description=SG process 1 for sg2;

#
# Note that the OPC value for BTS2 is 1-1-2
#
add opc id=opc1; point-code=1-1-2; description=OPC; point-code-type=ANSI_CHINA;
add dpc id=dpc1; point-code=1-1-30; description=DPC 1; point-code-type=ANSI_CHINA;
add dpc id=dpc2; point-code=1-1-31; description=DPC 2; point-code-type=ANSI_CHINA;

# TheISUP routing keys
#
# Note that a unique rc value was needed when defining the routing-key. It must match
# the rc value that is defined in the associated AS/routing-key definition in the ITPs.
# This routing key has a different OPC value than defined for BTS1.
#
add routing-key id=rk1; opc-id=opc1; sg-grp-id=sg-grp1; si=ISUP; rc=2; platform-id=CA147;

add call-ctrl-route id=dpc1-route1; dpc-id=dpc1; routing-key-id=rk1; si=isup;
user-part-variant-id= ANSISS7_GR317
```

```

add call-ctrl-route id=dpc2-route1; dpc-id=dpc2; routing-key-id=rk1; si=isup;
user-part-variant-id= ANSIS7_GR317;

add sctp-assoc-profile id=sctp-prof;

#
# The SCTP associations
#
add sctp-assoc id=sg1-sgp1-sctp; sgp-id=sg1-sgp1; sctp-assoc-profile-id=sctp-prof;
platform-id=CA147; remote-port=2905; remote-tsap-addr1=10.0.1.54;
remote-tsap-addr2=10.128.1.239; ip-tos-precedence=ROUTINE;

add sctp-assoc id=sg2-sgp1-sctp; sgp-id=sg2-sgp1; sctp-assoc-profile-id=sctp-prof;
platform-id=CA147; remote-port=2905; remote-tsap-addr1=10.0.1.55;
remote-tsap-addr2=10.128.1.240; ip-tos-precedence=ROUTINE;

#
# Dial plan profile
#
add digman-profile id=pretrans;
add digman id=pretrans; rule=1; match-string=^*; replace-string=&; match-noa=any;
replace-noa=VSC;
add digman id=pretrans; rule=2; match-string=^#; replace-string=&; match-noa=any;
replace-noa=VSC;
add digman-profile id=ani_20;
add digman id=ani_20; rule=1; match-string=^20; replace-string=none;
add dial-plan-profile id=dp-1; nanp-dial-plan=Y; description=NA dial plan profile;
dnis-digman-id=pretrans; ani-digman-id=ani_20;
#
# SS7 TG
#
add ss7-ansi-tg-profile ID=ansi-tg-prof;
add trunk-grp ID=1; call_agent_id=CA147; tg_type=SS7; direction=BOTH;
tg_profile_id=ansi-tg-prof; call-ctrl-route-id=dpc1-route1; dial-plan-id=dp-1;
description=TG to DPC 1; MGCP_PKG_TYPE=T;
add trunk-grp ID=2; call_agent_id=CA147; tg_type=SS7; direction=BOTH;
tg_profile_id=ansi-tg-prof; call-ctrl-route-id=dpc2-route1; dial-plan-id=dp-1;
description=TG to DPC 2; MGCP_PKG_TYPE=T;
#
# MGW
#
add mgw-profile id=as5300-prof; vendor=Cisco; mgcp-hairpin-supp=n; MGCP_RSIPSTAR_SUPP=N;
MGCP_TERM_INIT_LEVEL=0; RBK_ON_CONN_SUPP=N; MGCP_VERSION=MGCP_1_0; mgcp-max2-retries=3;
fax-t38-camode-supp=Y; mgcp-keepalive-interval=60; mgcp-keepalive-retries=10;
mgcp-t-tran=400; mgcp-max1-retries=2; mgcp-t-longtran=5; mgcp-default-pkg=NONE;
MGCP_3WAY_HSHAKE_SUPP=N; mgw_type=AS5300; PC_MPTIME_SUPP=N;
MGCP_VERSION=MGCP_1_0; PC_MPTIME_SUPP=N;
add mgw id=va-5350-23; tsap-addr=va-5350-23.hrndevtest.cisco.com; call-agent-id=CA147;
mgw-profile-id=as5300-prof; type=TGW;
#
# SS7 terminations and trunks
#
add termination prefix=S3/DS1-4/; port-start=1; port-end=31; type=trunk;
mgw-id=va-5350-23;
add termination prefix=S3/DS1-5/; port-start=1; port-end=31; type=trunk;
mgw-id=va-5350-23;
add trunk cic-start=1; cic-end=31; tgn-id=1; mgw-id=va-5350-23;
termination-prefix=S3/DS1-4/; termination-port-start=1; termination-port-end=31;
add trunk cic-start=1; cic-end=31; tgn-id=2; mgw-id=va-5350-23;
termination-prefix=S3/DS1-5/; termination-port-start=1; termination-port-end=31;
#
# SS7 routes, route guides and destinations
#
add route id=dpc1-route; tg_selection=RR; tgn1_id=1;

```

```

add route id=dpc2-route; tg_selection=RR; tgn1_id=2;
add route-guide id=dpc1-rg; policy-type=ROUTE; policy-id=dpc1-route;
add route-guide id=dpc2-rg; policy-type=ROUTE; policy-id=dpc2-route;
add destination dest-id=dpc1-dest; call-type=LOCAL; route-type=ROUTE;
route-guide-id=dpc1-rg;
add destination dest-id=dpc2-dest; call-type=LOCAL; route-type=ROUTE;
route-guide-id=dpc2-rg;

#
# TCAP/SUA provisioning for LNP
#

add sctp-assoc id=sg1-sgp1-sctp-ain; sgp-id=sg1-sgp1; sctp-assoc-profile-id=sctp-prof;
platform-id=FSAIN205; remote-port=14001; remote-tsap-addr1=10.0.1.54;
remote-tsap-addr2=10.128.1.239; ip-tos-precedence=ROUTINE;

add sctp-assoc id=sg2-sgp1-sctp-ain; sgp-id=sg2-sgp1; sctp-assoc-profile-id=sctp-prof;
platform-id=FSAIN205; remote-port=14001; remote-tsap-addr1=10.0.1.55;
remote-tsap-addr2=10.128.1.240; ip-tos-precedence=ROUTINE;

add sctp-assoc id=sg1-sgp1-sctp-ptc; sgp-id=sg1-sgp1; sctp-assoc-profile-id=sctp-prof;
platform-id=FSPTC235; remote-port=14001; remote-tsap-addr1=10.0.1.54;
remote-tsap-addr2=10.128.1.239; ip-tos-precedence=ROUTINE;

add sctp-assoc id=sg2-sgp1-sctp-ptc; sgp-id=sg2-sgp1; sctp-assoc-profile-id=sctp-prof;
platform-id=FSPTC235; remote-port=14001; remote-tsap-addr1=10.0.1.55;
remote-tsap-addr2=10.128.1.240; ip-tos-precedence=ROUTINE;

add sccp-nw id=1;NET_IND=NATIONAL;SUB_SVC=NATIONAL;HOP_COUNT=3;

add subsystem-profile id=SS_LNP; platform-id=FSAIN205; description=LNP subsystem;
add subsystem-profile id=SS_800A; platform-id=FSAIN205; description=AIN 800 subsystem;
add subsystem-profile id=SS_800T; platform-id=FSAIN205; description=IN1 800 subsystem;
add subsystem-profile id=SS_CNAM; platform-id=FSAIN205; description=CNAM subsystem;
add subsystem-profile id=SS_ACAR; platform-id=FSPTC235; description=ACAR subsystem;

add subsystem id=SS_LNP; opc-id=opc1; local-ssn=247; remote-ssn=247; sccp-nw-id=1;
SCCP_VERSION=ANS92; TCAP_VERSION=ANS92; APPLICATION_VERSION=AIN01;
add subsystem id=SS_800A; opc-id=opc1; local-ssn=248; remote-ssn=248; sccp-nw-id=1;
SCCP_VERSION=ANS92; TCAP_VERSION=ANS92; APPLICATION_VERSION=AIN01;
add subsystem id=SS_CNAM; opc-id=opc1; local-ssn=232; remote-ssn=232; sccp-nw-id=1;
SCCP_VERSION=ANS92; TCAP_VERSION=ANS92; APPLICATION_VERSION=IN1;
add subsystem id=SS_800T; opc-id=opc1; local-ssn=254; remote-ssn=254; sccp-nw-id=1;
SCCP_VERSION=ANS92; TCAP_VERSION=ANS92; APPLICATION_VERSION=IN1;
add subsystem id=SS_ACAR; opc-id=opc1; local-ssn=251; remote-ssn=251; sccp-nw-id=1;
SCCP_VERSION=ANS92; TCAP_VERSION=ANS92; APPLICATION_VERSION=IN1;

# Note this routing key differs from the one on BTS1
add routing-key id=rk_lnp; opc-id=opc1; sg-grp-id=sg_grp1; si=SCCP; rc=4502;
PLATFORM_ID=FSAIN205; ssn-id=SS_LNP;
add routing-key id=rk_800a; opc-id=opc1; sg-grp-id=sg_grp1; si=SCCP; rc=4503;
PLATFORM_ID=FSAIN205; ssn-id=SS_800A;
add routing-key id=rk_cnam; opc-id=opc1; sg-grp-id=sg_grp1; si=SCCP; rc=4504;
PLATFORM_ID=FSAIN205; ssn-id=SS_CNAM;
add routing-key id=rk_800t; opc-id=opc1; sg-grp-id=sg_grp1; si=SCCP; rc=4501;
PLATFORM_ID=FSAIN205; ssn-id=SS_800T;
add routing-key id=rk_acar; opc-id=opc1; sg-grp-id=sg_grp1; si=SCCP; rc=4505;
PLATFORM_ID=FSPTC235; ssn-id=SS_ACAR;

#
# Provisioned DPC is the STP capability point code
#

```

```

add dpc id=stp_cap_pc; point-code=1-1-22; point-code-type=ANSI_CHINA;
description=Capability Point Code of STPs

add feature fname=LNP; feature-server-id=FSAIN206; description=Local number portability;
tdp1=COLLECTED_INFORMATION; tid1=LNP_TRIGGER; ttype1=R;

add ported-office-code digit-string=301-612; in-call-agent=n;

add CA-Config type=DEFAULT-LNP-SLHR-ID; datatype=string; value=slhr_lnp;

add slhr-profile id=slhr_lnp;

add slhr id=slhr_lnp; gtt-req=Y; tt=11; GTT_ADDR_TYPE=CDPN; GTT_ADDR=3; opc-id=opc1;
dpc-id=stp_cap_pc; ssn-id=SSN_LNP1;

add sccp-route opc-id=opc1; dpc-id=stp_cap_pc; rk-id=itp-grp-rk2; ssn-id=SSN_LNP1;
description=LNP for opc1;

add pop ID=50901; STATE=tx; COUNTRY=US; TIMEZONE=CDT; LOCAL_7D_DIALING=Y; ITP=N;
ZERO_MINUS=LEC; BLOCK_EAWOPIC=Y; CNAM_OPTION=EXT_LIDB; PIC2_REQD=N; MY_LRN=4692559999;
TREAT_IMS_ANONYMOUS=N; OPC_ID=opc1; ZERO_PLUS_LOCAL=N

```

Multiple OPCs on the Cisco BTS 10200 Softswitch

This customer profile, illustrated in Figure 3-2, is based on the Mated STP-Pair profile. It is recommended for the customer who wants to emulate multiple legacy SS7 switches with one high-capacity BTS softswitch.

A similar A-link profile can also be implemented. However, the A-link profile requires a separate ITP-Group for each OPC on the BTS10200.

Figure 3-2 Multiple OPCs on the Cisco BTS 10200 Softswitch

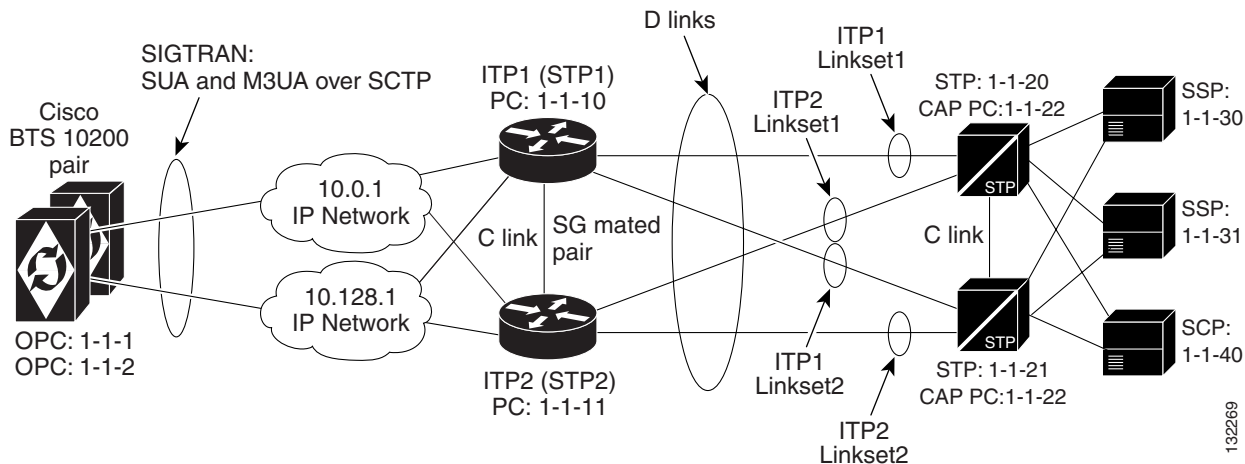

The BTS 10200 also supports up to 30 OPCs when the SIGTRAN signaling gateway supports SUA and M3UA in a D link configuration.

Configuration Requirements for Supporting 30 OPCs

The user must complete the following tasks to configure the BTS 10200 to support 30 OPCs:

- [Configuring the Subsystem_grp Table](#)
- [Configuring the Subsystem Table](#)
- [Configuring the SLHR Table](#)
- [Configuring the SCCP_Route Table](#)
- [Configuring the Routing_Key Table](#)
- [Controlling the Subsystem Group In or Out of Service](#)



Note

The following tasks include examples of CLI commands that illustrate how to provision the feature. Most of these tables have additional tokens that are not included in the examples. For a complete list of all CLI tables and tokens, refer to the *Cisco BTS 10200 Softswitch Command Line Interface Reference Guide*.

Configuring the Subsystem_grp Table

```
add subsystem_grp id=CNAM; platform_id=FSPTC235; tcap_version=ANS-92;
```

Configuring the Subsystem Table

```
add subsystem id=CNAM; opc-id=opc_tx; local-ssn=232; remote-ssn=232; sccp-nw-id=1;
SCCP_VERSION=ANS92; application-version=IN1;
```

```
add subsystem id=CNAM; opc-id=opc_nc; local-ssn=232; remote-ssn=232; sccp-nw-id=1;
SCCP_VERSION=ANS92; application-version=IN1;
```

Configuring the SLHR Table

```
add slhr id=slhr_cnam; opc-id=opc_tx; dpc-id=stp1; subsystem-grp-id=CNAM; gtt-req=Y; tt=5;
GTT_ADDR_TYPE=CLGN; GTT_ADDR=3;
```

Configuring the SCCP_Route Table

```
add sccp-route opc-id=opc_tx; dpc-id=stp1; subsystem-grp-id=CNAM; rk-id=rk_cnam_tx;
```

Configuring the Routing_Key Table

```
add routing-key id=rk_cnam_tx; opc-id=opc_tx; sg-grp-id=sg_grp; si=SCCP; rc=204;
PLATFORM_ID=FSPTC325; subsystem-grp-id=CNAM;
```

Controlling the Subsystem Group In or Out of Service

The Subsystem Group table has a status associated with it. The operator can control a subsystem group in or out of service. Controlling the subsystem group out of service has the same affect as controlling all the subsystems in the subsystem group out of service. Controlling the subsystem group in service puts all subsystems in the group in service.

The following CLI command controls both subsystem/OPC combinations out of service:

```
control subsystem_grp id=CNAM; mode=forced; target_state=UOS;
SUBSYSTEM GRP ID -> CNAM
INITIAL STATE -> User in service
RESULT STATE -> User out of service
REQUEST STATE -> User out of service
FAIL REASON -> ADM found no failure
REASON -> ADM executed successfully
RESULT -> ADM configure result in success
Reply : Success: CLI change successfull
```

Alternate Base Profiles

Although this profile is based on the Mated STP-Pair configuration, a similar Shared Point Code configuration can be implemented. However, it requires a separate ITP Group for each OPC on the BTS 10200.

ITP Configuration

The ITP configuration for this profile is essentially identical to the one for the Mated STP-Pair configuration documented in [Chapter 1, “SS7 Basic Configurations.”](#) However, there is an extra AS configuration for the added OPC on BTS1. This additional AS configuration information is shown here:

```
cs7 as BtsIsupAs2 m3ua
  routing-key 2 1.1.2 si isup
  asp PrimaryBtsIsupAsp
  asp SecondaryBtsIsupAsp
  traffic-mode override
  network-appearance 1

cs7 as LNP2_BTS1 sua
  routing-key 4412 1.1.2 si sccp ssn 247
  asp PRI_AIN_BTS1
  asp SEC_AIN_BTS1
  traffic-mode override

cs7 as 800T2_BTS1 sua
  routing-key 4411 1.1.2 si sccp ssn 254
  asp PRI_AIN_BTS1
  asp SEC_AIN_BTS1
  traffic-mode override
!
cs7 as 800A2_BTS1 sua
  routing-key 4413 1.1.2 si sccp ssn 248
  asp PRI_AIN_BTS1
  asp SEC_AIN_BTS1
  traffic-mode override
!
cs7 as CNAM2_BTS1 sua
  routing-key 4414 1.1.2 si sccp ssn 232
  asp PRI_PTC_BTS1
  asp SEC_PTC_BTS1
  traffic-mode override
!
cs7 as ACAR2_BTS1 sua
  routing-key 4415 1.1.2 si sccp ssn 251
```

```

asp PRI_PTC_BTS1
asp SEC_PTC_BTS1
traffic-mode override
!

```

Cisco BTS 10200 Softswitch Configuration Example

The BTS 10200 provisioning information is the same as the basic Mated STP-Pair configuration given in [Chapter 1, “SS7 Basic Configurations,”](#) with additional objects based on the provisioning of a second OPC, OPC 1.1.2. The BTS configuration is shown here:

```

#####
#
# CA configuration
#
#####

add ca-config type=MGCP-INIT-TERMS;value=160;datatype=integer;
add ca-config type=MGCP-INIT-DURATION;value=5;datatype=integer;
add ca-config type=MGCP-ICMP-PING-RETRANSMIT-DURATION;value=5;datatype=integer;
add ca-config type=MGCP-ICMP-PING-RETRY-COUNT;value=5;datatype=integer;
add ca-config type=MGCP-MAX-UNREACH-COUNT;value=5;datatype=integer;
add ca-config type=MGCP-MAX-FAULT-COUNT;value=5;datatype=integer;
add ca-config type=MGCP-ADM-RESP-TIME;value=300;datatype=integer;
add ca-config type=MGCP-SIG-TOS-LOWDELAY;value=Y;datatype=boolean;
add ca-config type=MGCP-SIG-TOS-PRECEDENCE;value=1;datatype=integer;
add ca-config type=MGCP-SIG-TOS-RELIABILITY;value=Y;datatype=boolean;
add ca-config type=MGCP-SIG-TOS-THROUGHPUT;value=Y;datatype=boolean;
#
# CA & FS
#
add call-agent id=CA146; tsap-addr-sidea=hrn11ca; mgw-monitoring-enabled=N;
add feature-server id=FSAIN205; tsap-addr-sidea=hrn11ca:11205; type=AIN;

#
# SIGTRAN and SS7 components
#
add user-part-variant id=ANSISS7_GR317;
add sg id=sg1; description=Signaling gateway 1;
add sg id=sg2; description=Signaling gateway 2;

add sg-grp id=sg-grp1; sg1-id=sg1; sg2-id=sg2 description=SG group 1;

add sgp id=sg1-sgp1 ; sg-id=sg1; description=SG process 1 for sg1;
add sgp id=sg2-sgp1 ; sg-id=sg2; description=SG process 1 for sg2;

add opc id=opc1; point-code=1-1-1; description=OPC1; point-code-type=ANSI_CHINA;

# The second OPC
add opc id=opc2; point-code=1-1-2; description=OPC2; point-code-type=ANSI_CHINA;

add dpc id=dpc1; point-code=1-1-30; description=DPC 1; point-code-type=ANSI_CHINA;
add dpc id=dpc2; point-code=1-1-31; description=DPC 2; point-code-type=ANSI_CHINA;

# The ISUP routing keys
add routing-key id=rk1; opc-id=opc1; sg-grp-id=sg-grp1; si=ISUP; rc=1; platform-id=CA146;

# The new ISUP routing key added for OPC2
add routing-key id=rk2; opc-id=opc2; sg-grp-id=sg-grp1; si=ISUP; rc=2; platform-id=CA146;

```

```

add call-ctrl-route id=dpc1-route1; dpc-id=dpc1; routing-key-id=rk1; si=isup;
user-part-variant-id= ANSIS7_GR317
add call-ctrl-route id=dpc2-route1; dpc-id=dpc2; routing-key-id=rk1; si=isup;
user-part-variant-id= ANSIS7_GR317;

# Two new routes added for OPC2
add call-ctrl-route id=dpc1-route2; dpc-id=dpc1; routing-key-id=rk2; si=isup;
user-part-variant-id= ANSIS7_GR317
add call-ctrl-route id=dpc2-route2; dpc-id=dpc2; routing-key-id=rk2; si=isup;
user-part-variant-id= ANSIS7_GR317;

add sctp-assoc-profile id=sctp-prof;

# The SCTP associations
add sctp-assoc id=sg1-sgp1-sctp; sgp-id=sg1-sgp1; sctp-assoc-profile-id=sctp-prof;
platform-id=CA146; remote-port=2905; remote-tsap-addr1=10.0.1.54;
remote-tsap-addr2=10.128.1.239; ip-tos-precedence=ROUTINE;

add sctp-assoc id=sg2-sgp1-sctp; sgp-id=sg2-sgp1; sctp-assoc-profile-id=sctp-prof;
platform-id=CA146; remote-port=2905; remote-tsap-addr1=10.0.1.55;
remote-tsap-addr2=10.128.1.240; ip-tos-precedence=ROUTINE;

#
# Dial plan profile
#
add digman-profile id=pretrans;
add digman id=pretrans; rule=1; match-string=^*; replace-string=&; match-noa=any;
replace-noa=VSC;
add digman id=pretrans; rule=2; match-string=^#; replace-string=&; match-noa=any;
replace-noa=VSC;
add digman-profile id=ani_20;
add digman id=ani_20; rule=1; match-string=^20; replace-string=none;
add dial-plan-profile id=dp-1; nanp-dial-plan=Y; description=NA dial plan profile;
dnis-digman-id=pretrans; ani-digman-id=ani_20;
#
# SS7 TG
#
add ss7-ansi-tg-profile ID=ansi-tg-prof;
add trunk-grp ID=1; call_agent_id=CA146; tg_type=SS7; direction=BOTH;
tg_profile_id=ansi-tg-prof; call-ctrl-route-id=dpc1-route1; dial-plan-id=dp-1;
description=TG to DPC 1; MGCP_PKG_TYPE=T;
add trunk-grp ID=2; call_agent_id=CA146; tg_type=SS7; direction=BOTH;
tg_profile_id=ansi-tg-prof; call-ctrl-route-id=dpc2-route1; dial-plan-id=dp-1;
description=TG to DPC 2; MGCP_PKG_TYPE=T;

# Two new trunk groups added for OPC2
#
add trunk-grp ID=3; call_agent_id=CA146; tg_type=SS7; direction=BOTH;
tg_profile_id=ansi-tg-prof; call-ctrl-route-id=dpc1-route2; dial-plan-id=dp-1;
description=TG2 to DPC 1; MGCP_PKG_TYPE=T;
add trunk-grp ID=4; call_agent_id=CA146; tg_type=SS7; direction=BOTH;
tg_profile_id=ansi-tg-prof; call-ctrl-route-id=dpc2-route2; dial-plan-id=dp-1;
description=TG2 to DPC 2; MGCP_PKG_TYPE=T;

#
# MGW
#
add mgw-profile id=as5300-prof; vendor=Cisco; mgcp-hairpin-supp=n; MGCP_RSIPSTAR_SUPP=N;
MGCP_TERM_INIT_LEVEL=0; RBK_ON_CONN_SUPP=N; MGCP_VERSION=MGCP_1_0; mgcp-max2-retries=3;
fax-t38-camode-supp=Y; mgcp-keepalive-interval=60; mgcp-keepalive-retries=10;
mgcp-t-tran=400; mgcp-max1-retries=2; mgcp-t-longtran=5; mgcp-default-pkg=NONE;
MGCP_3WAY_HSHAKE_SUPP=N; mgw_type=AS5300; PC_MPTIME_SUPP=N;
MGCP_VERSION=MGCP_1_0; PC_MPTIME_SUPP=N;

```

```

add mgw id=va-5350-23; tsap-addr=va-5350-23.hrndevtest.cisco.com; call-agent-id=CA146;
mgw-profile-id=as5300-prof; type=TGW;
#
# SS7 terminations and trunks
#
add termination prefix=S3/DS1-4/; port-start=1; port-end=31; type=trunk;
mgw-id=va-5350-23;

add termination prefix=S3/DS1-5/; port-start=1; port-end=31; type=trunk;
mgw-id=va-5350-23;

add trunk cic-start=1; cic-end=31; tgn-id=1; mgw-id=va-5350-23;
termination-prefix=S3/DS1-4/; termination-port-start=1; termination-port-end=31;

add trunk cic-start=1; cic-end=31; tgn-id=2; mgw-id=va-5350-23;
termination-prefix=S3/DS1-5/; termination-port-start=1; termination-port-end=31;

# New termination and trunk information for OPC2
#
add termination prefix=S3/DS1-6/; port-start=1; port-end=31; type=trunk;
mgw-id=va-5350-23;

add termination prefix=S3/DS1-7/; port-start=1; port-end=31; type=trunk;
mgw-id=va-5350-23;

add trunk cic-start=1; cic-end=31; tgn-id=3; mgw-id=va-5350-23;
termination-prefix=S3/DS1-6/; termination-port-start=1; termination-port-end=31;

add trunk cic-start=1; cic-end=31; tgn-id=4; mgw-id=va-5350-23;
termination-prefix=S3/DS1-7/; termination-port-start=1; termination-port-end=31;

#
# SS7 routes, route guides and destinations
#
add route id=dpc1-route; tg_selection=RR; tgn1_id=1;
add route id=dpc2-route; tg_selection=RR; tgn1_id=2;
add route-guide id=dpc1-rg; policy-type=ROUTE; policy-id=dpc1-route;
add route-guide id=dpc2-rg; policy-type=ROUTE; policy-id=dpc2-route;
add destination dest-id=dpc1-dest; call-type=LOCAL; route-type=ROUTE;
route-guide-id=dpc1-rg;
add destination dest-id=dpc2-dest; call-type=LOCAL; route-type=ROUTE;
route-guide-id=dpc2-rg;

# New route, route guide and destination information for OPC2
#
add route id=dpc1-route2; tg_selection=RR; tgn1_id=3;
add route id=dpc2-route2; tg_selection=RR; tgn1_id=4;
add route-guide id=dpc1-rg2; policy-type=ROUTE; policy-id=dpc1-route2;
add route-guide id=dpc2-rg2; policy-type=ROUTE; policy-id=dpc2-route2;
add destination dest-id=dpc1-dest2; call-type=LOCAL; route-type=ROUTE;
route-guide-id=dpc1-rg2;
add destination dest-id=dpc2-dest2; call-type=LOCAL; route-type=ROUTE;
route-guide-id=dpc2-rg2;

#
# TCAP/SUA Provisioning for LNP
#
add sctp-assoc id=sg1-sgp1-sctp-ain; sgp-id=sg1-sgp1; sctp-assoc-profile-id=sctp-prof;
platform-id=FSAIN205; remote-port=14001; remote-tsap-addr1=10.0.1.54;
remote-tsap-addr2=10.128.1.239; ip-tos-precedence=ROUTINE;

add sctp-assoc id=sg2-sgp1-sctp-ain; sgp-id=sg2-sgp1; sctp-assoc-profile-id=sctp-prof;
platform-id=FSAIN205; remote-port=14001; remote-tsap-addr1=10.0.1.55;
remote-tsap-addr2=10.128.1.240; ip-tos-precedence=ROUTINE;

```

```

add sctp-assoc id=sg1-sgpl-sctp-ptc; sgp-id=sg1-sgpl; sctp-assoc-profile-id=sctp-prof;
platform-id=FSPTC235; remote-port=14001; remote-tsap-addr1=10.0.1.54;
remote-tsap-addr2=10.128.1.239; ip-tos-precedence=ROUTINE;

add sctp-assoc id=sg2-sgpl-sctp-ptc; sgp-id=sg2-sgpl; sctp-assoc-profile-id=sctp-prof;
platform-id=FSPTC235; remote-port=14001; remote-tsap-addr1=10.0.1.55;
remote-tsap-addr2=10.128.1.240; ip-tos-precedence=ROUTINE;

add sccp-nw id=1;NET_IND=NATIONAL;SUB_SVC=NATIONAL;HOP_COUNT=3;

add subsystem-profile id=SS_LNP; platform-id=FSAIN205; description=LNP subsystem;
add subsystem-profile id=SS_800A; platform-id=FSAIN205; description=AIN 800 subsystem;
add subsystem-profile id=SS_800T; platform-id=FSAIN205; description=IN1 800 subsystem;
add subsystem-profile id=SS_CNAM; platform-id=FSAIN205; description=CNAM subsystem;
add subsystem-profile id=SS_ACAR; platform-id=FSPTC235; description=ACAR subsystem;

add subsystem id=SS_LNP; opc-id=opc1; local-ssn=247; remote-ssn=247; sccp-nw-id=1;
SCCP_VERSION=ANS92; TCAP_VERSION=ANS92; APPLICATION_VERSION=AIN01;
add subsystem id=SS_800A; opc-id=opc1; local-ssn=248; remote-ssn=248; sccp-nw-id=1;
SCCP_VERSION=ANS92; TCAP_VERSION=ANS92; APPLICATION_VERSION=AIN01;
add subsystem id=SS_CNAM; opc-id=opc1; local-ssn=232; remote-ssn=232; sccp-nw-id=1;
SCCP_VERSION=ANS92; TCAP_VERSION=ANS92; APPLICATION_VERSION=IN1;
add subsystem id=SS_800T; opc-id=opc1; local-ssn=254; remote-ssn=254; sccp-nw-id=1;
SCCP_VERSION=ANS92; TCAP_VERSION=ANS92; APPLICATION_VERSION=IN1;
add subsystem id=SS_ACAR; opc-id=opc1; local-ssn=251; remote-ssn=251; sccp-nw-id=1;
SCCP_VERSION=ANS92; TCAP_VERSION=ANS92; APPLICATION_VERSION=IN1;

# New subsystem ID for OPC2
add subsystem id=SS_LNP; opc-id=opc2; local-ssn=247; remote-ssn=247; sccp-nw-id=1;
SCCP_VERSION=ANS92; TCAP_VERSION=ANS92; APPLICATION_VERSION=AIN01;
add subsystem id=SS_800A; opc-id=opc2; local-ssn=248; remote-ssn=248; sccp-nw-id=1;
SCCP_VERSION=ANS92; TCAP_VERSION=ANS92; APPLICATION_VERSION=AIN01;
add subsystem id=SS_CNAM; opc-id=opc2; local-ssn=232; remote-ssn=232; sccp-nw-id=1;
SCCP_VERSION=ANS92; TCAP_VERSION=ANS92; APPLICATION_VERSION=IN1;
add subsystem id=SS_800T; opc-id=opc2; local-ssn=254; remote-ssn=254; sccp-nw-id=1;
SCCP_VERSION=ANS92; TCAP_VERSION=ANS92; APPLICATION_VERSION=IN1;
add subsystem id=SS_ACAR; opc-id=opc2; local-ssn=251; remote-ssn=251; sccp-nw-id=1;
SCCP_VERSION=ANS92; TCAP_VERSION=ANS92; APPLICATION_VERSION=IN1;

add routing-key id=rk_lnp; opc-id=opc1; sg-grp-id=sg_grp1; si=SCCP; rc=4402;
PLATFORM_ID=FSAIN205; ssn-id=SS_LNP;
add routing-key id=rk_800a; opc-id=opc1; sg-grp-id=sg_grp1; si=SCCP; rc=4403;
PLATFORM_ID=FSAIN205; ssn-id=SS_800A;
add routing-key id=rk_cnam; opc-id=opc1; sg-grp-id=sg_grp1; si=SCCP; rc=4404;
PLATFORM_ID=FSAIN205; ssn-id=SS_CNAM;
add routing-key id=rk_800t; opc-id=opc1; sg-grp-id=sg_grp1; si=SCCP; rc=4401;
PLATFORM_ID=FSAIN205; ssn-id=SS_800T;
add routing-key id=rk_acar; opc-id=opc1; sg-grp-id=sg_grp1; si=SCCP; rc=4405;
PLATFORM_ID=FSPTC235; ssn-id=SS_ACAR;

#
# New routing-key for OPC2
#
add routing-key id=rk_lnp2; opc-id=opc2; sg-grp-id=sg_grp1; si=SCCP; rc=4412;
PLATFORM_ID=FSAIN205; ssn-id=SS_LNP;
add routing-key id=rk_800a2; opc-id=opc2; sg-grp-id=sg_grp1; si=SCCP; rc=4413;
PLATFORM_ID=FSAIN205; ssn-id=SS_800A;
add routing-key id=rk_cnam2; opc-id=opc2; sg-grp-id=sg_grp1; si=SCCP; rc=4414;
PLATFORM_ID=FSAIN205; ssn-id=SS_CNAM;
add routing-key id=rk_800t2; opc-id=opc2; sg-grp-id=sg_grp1; si=SCCP; rc=4411;
PLATFORM_ID=FSAIN205; ssn-id=SS_800T;
add routing-key id=rk_acar2; opc-id=opc2; sg-grp-id=sg_grp1; si=SCCP; rc=4415;
PLATFORM_ID=FSPTC235; ssn-id=SS_ACAR;

```

```

#
# Provisioned DPC is the STP capability point code
#

add dpc id=stp_cap_pc; point-code=1-1-22; point-code-type=ANSI_CHINA;
description=Capability Point Code of STPs

add feature fname=LNP; feature-server-id=FSAIN205; description=Local number portability;
tdp1=COLLECTED_INFORMATION; tid1=LNP_TRIGGER; ttype1=R;

add ported-office-code digit-string=301-612; in-call-agent=n;

add CA-Config type=DEFAULT-LNP-SLHR-ID; datatype=string; value=slhr_lnp;

add slhr-profile id=slhr_800t; description=Service Logic Host Routing Table for IN1 800
Service;
add slhr-profile id=slhr_lnp; description=Service Logic Host Routing Table for AIN LNP
Service;
add slhr-profile id=slhr_800a; description=Service Logic Host Routing Table for AIN 800
Service;
add slhr-profile id=slhr_cnam; description=Service Logic Host Routing Table for IN1 CNAM
Service;
add slhr-profile id=slhr_acar; description=Service Logic Host Routing Table for ACAR
Service;

add slhr id=slhr_800t; opc-id=opc1; dpc-id=stp_cap_pc; ssn-id=SS_800T; gtt-req=Y; tt=254;
GTT_ADDR_TYPE=CDPN; GTT_ADDR=3;
add slhr id=slhr_lnp; opc-id=opc1; dpc-id=stp_cap_pc; ssn-id=SS_LNP; gtt-req=Y; tt=11;
GTT_ADDR_TYPE=CDPN; GTT_ADDR=3;
add slhr id=slhr_800a; opc-id=opc1; dpc-id=stp_cap_pc; ssn-id=SS_800A; gtt-req=Y; tt=8;
GTT_ADDR_TYPE=CDPN; GTT_ADDR=3;
add slhr id=slhr_cnam; opc-id=opc1; dpc-id=stp_cap_pc; ssn-id=SS_CNAM; gtt-req=Y; tt=5;
GTT_ADDR_TYPE=CLGN; GTT_ADDR=3;
add slhr id=slhr_acar; opc-id=opc1; dpc-id=stp_cap_pc; ssn-id=SS_ACAR; gtt-req=Y; tt=251;
GTT_ADDR_TYPE=CDPN; GTT_ADDR=10;

# New slhr for OPC2
add slhr id=slhr_800t; opc-id=opc2; dpc-id=stp_cap_pc; ssn-id=SS_800T; gtt-req=Y; tt=254;
GTT_ADDR_TYPE=CDPN; GTT_ADDR=3;
add slhr id=slhr_lnp; opc-id=opc2; dpc-id=stp_cap_pc; ssn-id=SS_LNP; gtt-req=Y; tt=11;
GTT_ADDR_TYPE=CDPN; GTT_ADDR=3;
add slhr id=slhr_800a; opc-id=opc2; dpc-id=stp_cap_pc; ssn-id=SS_800A; gtt-req=Y; tt=8;
GTT_ADDR_TYPE=CDPN; GTT_ADDR=3;
add slhr id=slhr_cnam; opc-id=opc2; dpc-id=stp_cap_pc; ssn-id=SS_CNAM; gtt-req=Y; tt=5;
GTT_ADDR_TYPE=CLGN; GTT_ADDR=3;
add slhr id=slhr_acar; opc-id=opc2; dpc-id=stp_cap_pc; ssn-id=SS_ACAR; gtt-req=Y; tt=251;
GTT_ADDR_TYPE=CDPN; GTT_ADDR=10;

add sccp-route opc-id=opc1; dpc-id=stp_cap_pc; ssn-id=SS_800T; rk-id=rk_800t;
add sccp-route opc-id=opc1; dpc-id=stp_cap_pc; ssn-id=SS_800A; rk-id=rk_800a;
add sccp-route opc-id=opc1; dpc-id=stp_cap_pc; ssn-id=SS_LNP; rk-id=rk_lnp;
add sccp-route opc-id=opc1; dpc-id=stp_cap_pc; ssn-id=SS_CNAM; rk-id=rk_cnam;
add sccp-route opc-id=opc1; dpc-id=stp_cap_pc; ssn-id=SS_ACAR; rk-id=rk_acar;

add sccp-route SSN_ID=SS_ACAR; OPC_ID=opc1; DPC_ID=dpc1; RK_ID=rk_acar
add sccp-route SSN_ID=SS_ACAR; OPC_ID=opc1; DPC_ID=dpc2; RK_ID=rk_acar

# New sccp-route for OPC2
#
add sccp-route opc-id=opc2; dpc-id=stp_cap_pc; ssn-id=SS_800T; rk-id=rk_800t2;
add sccp-route opc-id=opc2; dpc-id=stp_cap_pc; ssn-id=SS_800A; rk-id=rk_800a2;

```

```

add sccp-route opc-id=opc2; dpc-id=stp_cap_pc; ssn-id=SS_LNP; rk-id=rk_lnp2;
add sccp-route opc-id=opc2; dpc-id=stp_cap_pc; ssn-id=SS_CNAM; rk-id=rk_cnam2;
add sccp-route opc-id=opc2; dpc-id=stp_cap_pc; ssn-id=SS_ACAR; rk-id=rk_acar2;

add sccp-route SSN_ID=SS_ACAR; OPC_ID=opc2; DPC_ID=dpc1; RK_ID=rk_acar2
add sccp-route SSN_ID=SS_ACAR; OPC_ID=opc2; DPC_ID=dpc2; RK_ID=rk_acar2
_PLUS_LOCAL=N
#
# New pop for OPC2
#
add pop ID=50902; STATE=tx; COUNTRY=US; TIMEZONE=CDT; LOCAL_7D_DIALING=Y; ITP=N;
ZERO_MINUS=LEC; BLOCK_EAWOPIC=Y; CNAM_OPTION=EXT_LIDB; PIC2_REQD=N; MY_LRN=4692559991;
TREAT_IMS_ANONYMOUS=N; OPC_ID=opc2; ZERO_PLUS_LOCAL=N

```

Multiple Cisco BTS 10200 Softswitch Nodes Sharing the Same OPC

This profile, illustrated in [Figure 3-3](#), is used when a customer wants to share a single OPC among multiple BTS nodes. When this feature is utilized, traffic is divided in one of two ways:

1. Traffic can be split between the BTS nodes based on a per call control route basis. In this case, the BTS nodes will not be provisioned with the same DPC. This means that only one of the BTS nodes will send traffic to and receive traffic from the associated DPC in the service provider network.
2. Traffic can also be split on a per call control route/CIC range basis. In this case, the same DPC (and call control route) can be provisioned for multiple BTS nodes, but the associated trunk group will be provisioned with a CIC range that differs on each BTS node.

This customer profile is subject to the following limitations:

- Multiple BTS 10200 nodes sharing a single point code is only valid for ISUP. If TCAP queries are needed, a separate TCAP OPC will be needed for each BTS 10200.
- If a provisioned DPC on one BTS is also provisioned on any other BTS, then load must be divided between the BTS nodes based on CIC range.
- When provisioning call control routes on the BTS, you cannot provision two different call control routes that have the same routing key and DPC information.



Note

This customer profile is valid for Mated STP Pair and Shared Point Code topologies. For the Shared Point Code topologies that connect via A, F, and E-links, the point code of the ITP Group is shared by the BTS.

Figure 3-3 Multiple BTS Nodes Sharing the Same Point Code

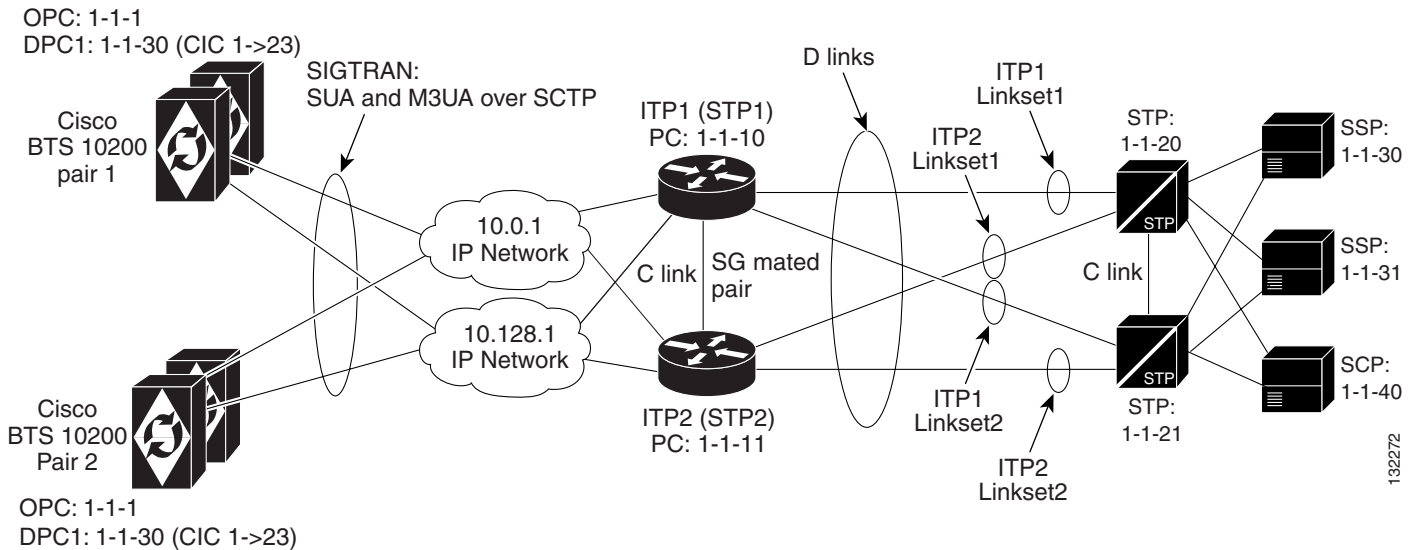

Cisco ITP Configuration Example

This example shows an AS and ASP configuration and is only for M3UA. For a default Mated STP-Pair configuration, which includes SUA, refer to [Chapter 1, “SS7 Basic Configurations,”](#)

For additional ITP configuration information, refer to the *Cisco ITP Configuration Guide* at: <http://www.cisco.com/univercd/cc/td/doc/product/wireless/moblrwls/itp>



Note

When debugging the ITP, the version of the ITP should be noted so the associated ITP manual can be consulted.

This configuration information is similar to a basic Mated STP-Pair configuration, except that in this example there will be extra ASP configuration information for communicating to the second call agent (CA)(BTS2). Also, there is extra information in the AS configuration section for routing to each of the BTS 10200 nodes, based on CIC range. Shown below are the ASP and AS configuration elements for ITP1.



Note

ITP2 will have the same ASP and AS configuration information that is shown below for ITP1.

```
! ASP configuration for BTS1
!
cs7 asp PRI_ISUP_BTS1 11146 2905 m3ua
  remote-ip 10.0.1.5
  remote-ip 10.128.1.2

cs7 asp SEC_ISUP_BTS1 11146 2905 m3ua
  remote-ip 10.0.1.6
  remote-ip 10.128.1.3
!
! ASP configuration for BTS2
!
```

```

cs7 asp PRI_ISUP_BTS2 11146 2905 m3ua
  remote-ip 10.0.1.7
  remote-ip 10.128.1.4

cs7 asp SEC_ISUP_BTS2 11146 2905 m3ua
  remote-ip 10.0.1.8
  remote-ip 10.128.1.5

!
! AS configuration for BTS1
!
! Note: In the following configuration the routing context entries are as follows:
! routing context = 1, DPC(BTS OPC)=1.1.1, opc=1.1.30, mask is 255.255.255, service
! indicator=ISUP, CIC range=1->23
!
! Configuring network-appearance 1 is required for release 4.4, but must not be used
! in release 4.5 and beyond.
!
cs7 as ISUP_BTS1 m3ua
  routing-key 1 1.1.1 opc 1.1.30 255.255.255 si isup cic 1 23
  asp PRI_ISUP_BTS1
  asp SEC_ISUP_BTS1
  traffic-mode override
  network-appearance 1
!
! AS configuration for BTS2
! Note that the CIC range changes to 24->46 for sending messages to BTS2
!
cs7 as ISUP_BTS1 m3ua
  routing-key 2 1.1.1 opc 1.1.30 255.255.255 si isup cic 24 46
  asp PRI_ISUP_BTS2
  asp SEC_ISUP_BTS2
  traffic-mode override
  network-appearance 1
!
! Note that additional AS configurations will be needed for other DPCs (such as 1-1-31).

```

Cisco BTS10200 Softswitch Provisioning Example

BTS1 Provisioning

The following example documents BTS1 provisioning for routing key/CIC based routing. It is important to note that, unlike the ITP, the BTS does not configure CIC ranges within the routing key. Instead, the CIC ranges on the BTS are provisioned as part of the trunk object.

```

add opc id=opc1; point-code=1-1-1; point-code-type=ANSI_CHINA;
add dpc id=dpc1; point-code=1-1-30; point-code-type=ANSI_CHINA;
add dpc id=dpc2; point-code=1-1-31; point-code-type=ANSI_CHINA;
add sg id=sg1; priority=1;
add sg id=sg2; priority=1;
add sg-grp id=sg-grp1; sg1-id=sg1; sg2-id=sg2;
add sgp id=sg1-sgp1; sg-id=sg1;
add sgp id=sg2-sgp2; sg-id=sg2;
add sctp-assoc-profile id=sctp-prof1;

add sctp-assoc id=sg1-sgp1-sctp; sgp-id=sgp1; sctp-assoc-profile-id=sctp-prof1;
platform-id=CA146; remote-port=2905; remote-tsap-addr1=10.89.225.235;
remote-tsap-addr2=10.89.226.235; dip-tos-precedence=ROUTINE;

```

```

add sctp-assoc id=sg2-sgp2-sctp; sgp-id=sgp2; sctp-assoc-profile-id=sctp-prof1;
platform-id=CA146; remote-port=2905; remote-tsap-addr1=10.89.225.236;
remote-tsap-addr2=10.89.226.236; ip-tos-precedence=ROUTINE;

add user-part-variant id=ANSISS7_GR317;

#
# NOTE THAT RC VALUE IN BTS CONFIG MATCHES RC VALUE IN ITP CONFIG
#
add routing-key id=rk1; opc-id=opc1; sg-grp-id=sg-grp1; si=ISUP; rc=1; platform-id=CA146;

add call-ctrl-route id=dpc1-route; dpc-id=dpc1; routing-key-id=rk1; si=ISUP;
user-part-variant-id=ANSISS7_GR317;
add call-ctrl-route id=dpc2-route; dpc-id=dpc2; routing-key-id=rk2; si=ISUP;
user-part-variant-id=ANSISS7_GR317;
add mgw-profile id=as5300-prof; mgw-type=AS5300; mgcp-version=MGCP_1_0;
add mgw id=as5300-1; mgw-profile-id=as5300-prof; call-agent-id=CA146;
tsap-addr=as5300-1.cisco.com; type=TW;
add termination prefix=S1/DS1-0/; port-start=1; port-end=23 or 31; type=trunk;
mgw-id=as5300-1;

add ss7-ansi-tg-profile id=ss7-prof1;
add trunk-grp id=1; call-agent-id=CA146; tg-type=SS7; tg-profile=ss7-prof1;
call-ctrl-route-id=dpc1-route;

#
# Notethat the CIC range in the BTS trunk matches the one in the ITP as rkey
configuration.
#
# Also note that the CIC range is not defined in the routing-key for the BTS. It is
# defined # as part of the trunk object. It is however possible to define the DPC in this
# routing key, but it is not necessary and was not done here.
#
add trunk cic-start=1; cic-end=23; type=trunk; mgw-id=as5300-1;
termination-prefix=S1/DS1-0/; tgn-id=1; termination-port-start=1; termination-port-end=23;

add route id=dpc1-route; tg-selection=RR; tgn1-id=1;

add route-guide id=dpc1-rg; policy-type=ROUTE; policy-id=dpc1-route;

add destination id=dpc1-dest; route-type=ROUTE; route-guide-id=dpc1-rg;

```

BTS2 Provisioning

The following example documents BTS2 provisioning for routing key/CIC based routing.

```

add opc id=opc1; point-code=3-10-3; point-code-type=ANSI_CHINA;
add dpc id=dpc1; point-code=3-50-3; point-code-type=ANSI_CHINA;
add dpc id=dpc2; point-code=3-51-3; point-code-type=ANSI_CHINA;
add sg id=sg1; priority=1;
add sg id=sg2; priority=1;
add sg-grp id=sg-grp1; sg1-id=sg1; sg2-id=sg2;
add sgp id=sgp1; sg-id=sg1;
add sgp id=sgp2; sg-id=sg2;
add sctp-assoc-profile id=sctp-prof1;

add sctp-assoc id=ca-sgp1-sctp; sgp-id=sgp1; sctp-assoc-profile-id=sctp-prof1;
platform-id=CA147; remote-port=2905; remote-tsap-addr1=10.89.225.235;
remote-tsap-addr2=10.89.226.235; ip-tos-precedence=ROUTINE;

```

```

add sctp-assoc id=ca-sgp2-sctp; sgp-id=sgp2; sctp-assoc-profile-id=sctp-prof1;
platform-id=CA147; remote-port=2905; remote-tsap-addr1=10.89.225.236;
remote-tsap-addr2=10.89.226.236; ip-tos-precedence=ROUTINE;

add user-part-variant id=ANSISS7_GR317;
#
# Note that RCvalue in the BTS configuration matches the RC value in the ITP
configuration.
#
# Also note that the CIC range is not defined in the routing key for the BTS. It is
defined
# as part of the trunk object. It is, however, possible to define the DPC in this routing
# key, but it is not necessary and was not done here.
#
add routing-key id=rk3; opc-id=opc1; sg-grp-id=sg-grp1; si=ISUP; rc=2; platform-id=CA146;

add call-ctrl-route id=dpc1-route; dpc-id=dpc1; routing-key-id=rk3; si=ISUP;
user-part-variant-id=ANSISS7_GR317;
add call-ctrl-route id=dpc2-route; dpc-id=dpc2; routing-key-id=rk4; si=ISUP;
user-part-variant-id=ANSISS7_GR317;
add mgw-profile id=as5300-prof; mgw-type=AS5300; mgcp-version=MGCP_1_0;
add mgw id=as5300-1; mgw-profile-id=as5300-prof; call-agent-id=CA146;
tsap-addr=as5300-1.cisco.com; type=MGW;
add termination prefix=S1/DS1-0/; port-start=1; port-end=23 ; type=trunk; mgw-id=as5300-2;
add ss7-ansi-tg-profile id=ss7-prof1;

add trunk-grp id=1; call-agent-id=CA147; tg-type=SS7; tg-profile=ss7-prof1;
call-ctrl-route-id=dpc1-route;

#
# Note that the CIC range in the BTS trunk matches the one in the
# ITP AS routing key configuration.
#
add trunk cic-start=24; cic-end=46; type=trunk; mgw-id=as5300-2;
termination-prefix=S1/DS1-0/; tgn-id=1; termination-port-start=1; termination-port-end=23;

add route id=dpc1-route; tg-selection=RR; tgn1-id=1;
add route-guide id=dpc1-rg; policy-type=ROUTE; policy-id=dpc1-route;
add destination id=dpc1-dest; route-type=ROUTE; route-guide-id=dpc1-rg;

```

Geographically Separated Mated STP Pair with SG Priority Routing

This customer profile, illustrated in [Figure 3-4](#), is recommended for the customer who operates two different geographically separated telephony networks using geographically separated BTS and ITP nodes. In this example, BTS1 and ITP1 are located in Dallas, and BTS2 and ITP2 are in Washington, DC.

The topology between ITPs and STPs is an SS7 STP quad. The SG Mated Pair could be connected to an STP, a service provider's STP mated pair, or the gateway STPs provided by the local service provider. The ITP pair can be colocated with the BTS in the customer's network or colocated with the STP pair in the service provider's network.

A key component of this profile is the use of SG priority routing, which provides the ability to choose which SG in the SG-Group has priority when sending towards the destinations. In this example, BTS1 will primarily send toward the DPCs (SSPs) in the Dallas network via ITP1, and it will only route through ITP2 for these end-points at a lower priority. This is useful for cost reduction if, for example, BTS1 has a POP in Dallas and BTS2 has a POP in Washington, DC.

This customer profile is valid only for the D-link configuration.



Note

Figure 3-4 only shows one STP in each city. However, each city would probably contain two network STPs.

Figure 3-4 Geographically Distributed Mated STP Pair Configuration with SG Priority Routing

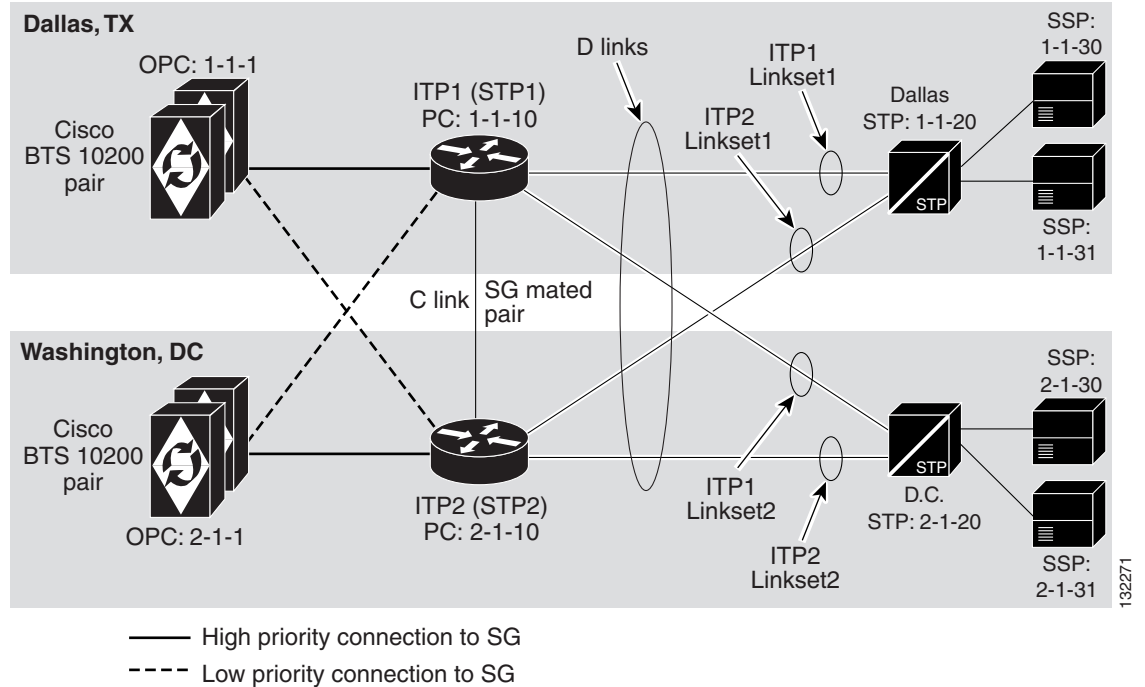

132271

Cisco ITP Configuration Example

The ITP configuration in this example is similar to the one in [ITP1 Configuration, page 2-7](#), with the following exceptions:

- In [Figure 3-4](#), only one STP is shown as a route towards each SSP
- The routes through STP1 and STP2 lead towards different endpoints

The following is the configuration example for the cs7 linksets and routes:

```
#
# SS7 Linkset definitions. Note: the number after 'link' represents SLC
#
cs7 linkset lset1chn 1.1.20
  link 0 Serial10/0:0
!
cs7 linkset lset2chn 2.1.20
  link 0 Serial10/1:0
#
# SS7 Route definitions
```

```
#
cs7 route-table system
update route 1.1.30 255.255.255 linkset lset1chn priority 1
update route 1.1.31 255.255.255 linkset lset1chn priority 1
update route 2.1.30 255.255.255 linkset lset2chn priority 1
update route 2.1.31 255.255.255 linkset lset2chn priority 1
```

Cisco BTS10200 Softswitch Provisioning Example

In this BTS provisioning script, each BTS assigns one of the SGs of the SG-Group as a priority 1 SG route while the other BTS assigns it as a priority 2 SG route. In the BTS1 provisioning script, SG1 has a priority of 1 while SG2 has a priority of 2. In the BTS2 provisioning script, SG2 has a priority of 1 while SG1 has a priority of 2.

The following is a provisioning example for configuring SG priorities.

BTS1 Provisioning

```
#
# SG configuration for BTS1. Note how the priority is provisioned opposite
# of what will be done on BTS2 (as shown in the next subsection).
#
add sg id=sg1; description=Signaling gateway 1 of SG GRP 1; priority 1
add sg id=sg2; description=Signaling gateway 2 of SG GRP 1; priority 2
#
# SG-GRP configuration for BTS1
#
add sg-grp id=sg-grp1; sg1-id=sg1; sg2-id=sg2 description=SG group 1;
```

BTS2 Provisioning

```
#
# SG configuration for BTS2. Note how the priority is provisioned opposite
# of what it is for BTS1.
#
add sg id=sg1; description=Signaling gateway 1 of SG GRP 1; priority 2
add sg id=sg2; description=Signaling gateway 2 of SG GRP 1; priority 1
#
# SG-GRP configuration for BTS2
#
add sg-grp id=sg-grp1; sg1-id=sg1; sg2-id=sg2 description=SG group 1;
```

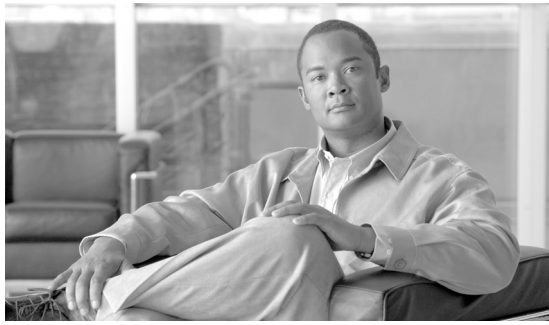

CHAPTER 4

SS7 SIGTRAN Troubleshooting

Revised: May 7, 2007, OL-12779-02

This chapter describes tools and procedures for troubleshooting SIGTRAN problems on the Cisco BTS 10200 Softswitch and Cisco ITP, for clearing Cisco BTS 10200 Softswitch alarms, and for troubleshooting network problems. When an alarm is raised on the BTS 10200, a series of steps may be required to determine the source of the problem and may include viewing other alarms, invoking CLI status and control commands, viewing the BTS 10200 logs, and invoking ITP control and status requests.

This chapter contains the following sections:

- [Cisco ITP Troubleshooting Procedures](#)
- [Cisco BTS 10200 Softswitch Troubleshooting Procedures](#)
- [Troubleshooting Cisco BTS 10200 Softswitch Alarms](#)
- [Debugging Network Problems for TCAP/SCCP Applications](#)
- [Troubleshooting With the Query Command](#)

Cisco ITP Troubleshooting Procedures

The following procedures are useful for troubleshooting problems on the Cisco ITP:

ITP System Messages

The Cisco ITP displays system messages when you are logged in to the console port. Some of these messages are similar to alarms. Analyzing ITP system messages is outside the scope of this document. For details concerning ITP system messages, please see the ITP Operations Manual at:

<http://www.cisco.com/univercd/cc/td/doc/product/wireless/moblwrls/itp>



Note

When debugging the ITP, note the version of the ITP so the associated ITP Operations Manual can be consulted.

Logging On to the ITP

Some of the troubleshooting sections in this chapter require the user to log on to the ITP. Access the ITP through the associated console server or through direct access with a console cable. You need the username and password to access the ITP.

Troubleshooting the ITP will require you to be in ITP enable mode. To get into enable mode, after logging in to the ITP, type **enable**. You will be prompted for the enable password.

Viewing the ITP Configuration

To view the ITP configuration, log in to the ITP and get into enable mode. Enter the command **show run**. The configuration will be displayed. Continue to hit the enter key until you have viewed the entire configuration, or type “q” to stop viewing the configuration.

ITP Status Commands

The following ITP commands are helpful for displaying the status of ITP resources:

- `show cs7 as`—Retrieves the AS status
- `show cs7 asp`—Retrieves the ASP status
- `show cs7 linkset`—Retrieves the SS7 linkset status
- `show cs7 route`—Retrieves the SS7 route status
- `show cs7 group state`—Retrieves the SG-Group status

Controlling ITP Resources

Change the administrative state of an ITP resource as follows:

-
- Step 1** Log on to the ITP, and get into configure mode.
 - Step 2** Type the first configuration line of the resource that you want to control.
 - Step 3** Type **shut** to take the resource out of service, or type **no-shut** to place the resource back in service.
-

The following example takes a linkset out of service:

```
va-2651-33#conf t
Enter configuration commands, one per line va-2651-33(config-cs7-ls)#
va-2651-33(config)#cs7 linkset lset1 1.1.20

va-2651-33(config-cs7-ls)#shut
*May 19 12:32:13.827: %CS7MTP3-5-ACTDEACTLINKSET: Linkset lset1 deactivation is in
progress
*May 19 12:32:13.827: %CS7MTP3-5-LINKUPDOWN: Link 0 in linkset lset1 is down
```

To put the linkset back in service, type the following command:

```
va-2651-33(config-cs7-ls)#no shut
```

```
*May 19 12:33:47.704: %CS7MTP3-5-ACTDEACTLINKSET: Linkset lset1 activation is in progress
*May 19 12:33:47.704: %CS7MTP3-5-ACTDEACTLINK: Link 0 linkset lset1 activation is in progress
```

Cisco BTS 10200 Softswitch Troubleshooting Procedures

Using Cisco BTS 10200 Softswitch CLI Commands

In the following sections, examples of BTS CLI commands are used to aid in resolving BTS alarms. The following CLI commands are helpful to display and clear alarms:

To display all the currently active alarms, enter the following command at a CLI prompt:

```
show alarm
```

To display all alarms of a specific type, enter:

```
show alarm type=<alarm type>
```

To clear an alarm, enter the following command:

```
clear alarm id=<alarm id>
```

For a detailed description of the CLI commands that are used, see the *Cisco BTS 10200 Softswitch Command Line Interface Reference Guide, Release 4.4*, at the following URL:

http://www.cisco.com/univercd/cc/td/doc/product/voice/bts10200/bts4_4/cli/index.htm

Viewing Cisco BTS 10200 Softswitch Logs

Viewing BTS 10200 logs is helpful when debugging M3UA related objects on the BTS 10200. Specific string patterns are printed out by the M3UA Interface Module and are useful to determine what is occurring in the log. These strings are formatted as follows:

```
MIM <functional area> <network object>
```

Functional areas include:

- CFG
- STATUS
- PDU
- STATISTICS
- CTRL
- PLATFORM

Network objects include:

- SCTP
- SGP
- SG
- DPC

- OPC
- ROUTING-KEY
- CALL-CONTROL-ROUTE

Search or grep the following example strings when searching the BTS 10200 logs:

- MIM CFG SCTP—Display how the SCTP has been configured at startup.
- MIM PDU—Trace the incoming messages at the MIM layer.
- MIM STATUS DPC—Display how the DPC status has changed in the system.
- MIM STATUS SCTP—Display how the SCTP status has changed in the system.
- MIM PLATFORM—Determine if a platform state change has been issued to the SGA/MIM module.
- MIM CTRL SCTP—Determine if an SCTP association has been administratively taken out of service or put back in service.

Troubleshooting Cisco BTS 10200 Softswitch Alarms

When an alarm is raised on the BTS, you must determine whether the issue is in the IP network, on the ITP, or in the PSTN. Subsequent sections provide troubleshooting steps for the following BTS SS7 and Sigtran related alarms raised on the BTS. Click on the alarm name to display troubleshooting information for that alarm at both the M3UA and SUA layers.

Table 4-1 Cisco BTS 10200 Softswitch SS7 and Sigtran Alarms

Alarm Type	Alarm Name	Alarm Severity
SIGNALING(23)	DPC Unavailable	MAJOR
SIGNALING(116)	DPC User Part Unavailable	MAJOR
SIGNALING(24)	DPC Congested	MINOR
SIGNALING(110)	Signaling Gateway Group Is Out of Service	CRITICAL
SIGNALING(113)	Signaling Gateway Failure	MAJOR
SIGNALING(114)	Signaling Gateway Process Is Out of Service	MAJOR
SIGNALING(109)	SCTP Association Failure	MAJOR
SIGNALING(111)	SCTP Association Degraded	MINOR
SIGNALING(112)	SCTP Association Configuration Error	MINOR
SIGNALING(122)	M3UA Cannot Go Active	MAJOR
SIGNALING(121)	M3UA Cannot Go Standby	MAJOR
SIGNALING(127)	TCAP Binding Failure	MAJOR
SIGNALING(124)	Remote Subsystem Is Out Of Service	MINOR

DPC Unavailable

This alarm indicates that the BTS is unable to communicate with the specified DPC in the SS7 network. Determine if the issue is a communication problem between the BTS and the ITP or if it is related to communication problems between the ITP and the DPC by following these steps:

-
- Step 1** Use the BTS CLI show alarm command to determine if there is an active Signaling Gateway Group Out of Service alarm. This will occur if communication has been lost to both of the SGs in the SG-Group. If so, proceed to the [“Signaling Gateway Group Is Out of Service” section on page 4-6](#). Otherwise, proceed to Step 2.
- Step 2** Determine if there is an M3UA Cannot Go Active alarm. This occurs if, at the time of startup or failover, the BTS is not able to communicate with any of the SGs. If this is the case, proceed to the [“M3UA Cannot Go Active” section on page 4-10](#). Otherwise, proceed to Step 3.
- Step 3** If you arrive at this step, there is probably communication between the BTS and ITP at the M3UA and SUA layers, and a communication problem exists between the ITP and the unavailable DPC. To confirm this, log on to each ITP, get into enable mode, and enter **show cs7 route**. The output of this command tells you if the associated DPC is accessible or not from the ITP point of view and will look similar to the following:
- ```
va-2651-82#show cs7 route
Destination Prio Linkset Name Route

229.123.2/24 INACC 1 lset1chn UNAVAIL
```
- This output indicates that DPC 229.123.2 is unavailable from the ITP point of view..
- Step 4** Determine if the problem is at the link level or at a higher level outage in the DPC by typing **show cs7 linkset**. If the ITP shows that the DPC is AVAIL, there is a configuration mismatch between the ITP and BTS.
- Step 5** Check whether the DPC has been removed from the BTS database. At the BTS CLI prompt, enter **show call-ctrl-route** or **show sccp-route** and see if the DPC is in any of the routes. If not, the alarm was raised before the associated routes were deleted. If this is the case, manually clear the alarm.
- Step 6** If you still cannot determine the cause of the problem, contact the Cisco TAC.
- 

## DPC User Part Unavailable

This alarm indicates that a layer 4 user part, such as ISUP, is unavailable at the DPC in the SS7 network. Contact your SS7 service provider for help in resolving this problem.

## DPC Congested

This alarm indicates that the DPC in the SS7 network is congested, i.e., is in a state where it has received more traffic than it can handle. This should be a temporary state. If the type of network is National, which is generally the case in the United States, there will also be a level of congestion associated with the alarm.

The ITP should continually communicate with the DPC in the SS7 network to determine if congestion has abated. If this alarm does not clear or keeps reappearing after clearing, contact your SS7 service provider to determine why the DPC is congested.

## Signaling Gateway Group Is Out of Service

This alarm indicates that after communication to the SG group was established, it was lost. This indicates that communication to the associated SGs is down, which also indicates that communication to all SGPs is down. See the [“Signaling Gateway Failure” section on page 4-6](#) to determine why the associated SGs are down.

## Signaling Gateway Failure

This alarm indicates that communication at the M3UA or SUA layer to an SG has failed. M3UA communications at all SGPs that make up the SG are unavailable. See the [“Signaling Gateway Process Is Out of Service” section on page 4-6](#) to determine why the associated SGPs are down.

## Signaling Gateway Process Is Out of Service

This alarm indicates that communication at the M3UA or SUA layer to an SGP has failed. In the majority of cases, there will also be a related SCTP Association Failure alarm. If this is the case, proceed to the [“SCTP Association Failure” section on page 4-6](#). Otherwise, the problem is at the M3UA layer. Call the Cisco TAC for assistance.

## SCTP Association Failure

This alarm indicates that the BTS is unable to communicate with an SGP at the SCTP protocol level.

If the application for which SCTP is providing transport is ISUP, please refer to [Debugging SCTP Problems for ISUP Applications](#).

If the application for which SCTP is providing transport is TCAP/SCCP, please refer to [Debugging SCTP Problems for TCAP/SCCP Applications](#).

## Debugging SCTP Problems for ISUP Applications

Use the following steps to determine the source of the problem at the M3UA layer:

---

**Step 1** Determine if the administrative state of the SCTP is correct.

a. Type the following command at the BTS CLI prompt:

```
status sctp-assoc id=<sctp-assoc-name>
```

If the response displays ADMIN STATE ->ADMIN\_OOS, the SCTP association has been taken administratively out of service and needs to be put back in service.

b. Enter the following command to put the SCTP association in service:

```
control sctp-assoc id=<sctp-assoc-name>; mode=forced; target-state=INS;
```

c. If the administrative state is ADMIN\_INS, determine if the association has been taken out of service on the ITP. Log on to the ITP. If you are unable to log on to the ITP, proceed to Step 2.

- d. If you are able to log on to the ITP, check the state of the associated ASP by entering the following command:

```
show cs7 asp
```

The following is an example of the output:

| ASP Name | AS Name  | State    | Type | Rmt Port | Remote IP Addr | SCTP |
|----------|----------|----------|------|----------|----------------|------|
| hrn11asp | hrn11bts | shutdown | M3UA | 11146    | 10.0.5.13      |      |

- e. If the state of the ASP indicates shutdown, someone has administratively taken the association out of service. Refer to the *Cisco ITP User's Guide*, at the following URL, to put the ASP (SCTP association) back in service:

<http://www.cisco.com/univercd/cc/td/doc/product/wireless/moblwrls/itp>



**Note**

When debugging the ITP, note the version of the ITP so the associated ITP Operations Manual can be consulted.

- f. If the state is down proceed to Step 2.
- g. If the state of the ASP is inactive, the ASP is probably on the standby BTS. If the ASP on the active BTS is inactive, proceed to Step 7.

**Step 2** Determine if the problem is an IP address or port configuration mismatch between the ITP and the BTS.

- a. Determine the BTS configured values for the BTS IP addresses and port. Look for the DNS name and port number that are configured for the SGA process in `/opt/OptiCall/CA146/bin/platform.cfg`. Go to the specified directory and enter:

```
cat platform.cfg | grep mdl
```

The output will look similar to the following:

```
Args=-t 1 -h mgcp-HRN11CA.hrndevtest.cisco.com -p 11146 -mldir ../mdl -mdltracedir
../mdltrace -mdltestmode 0 -mdlloadmdo 0 -mdltriggertimer 200 -mdlgarbagetimer 5146
-resetcics 1 -fcmtimer 900 -fcmparalleljobs 4
```

- The local IP port number is shown directly after the `-p` option.
- The local IP addresses that are used by the BTS are derived from the DNS name, which is given directly after the `-h` option. At the BTS UNIX prompt, enter:

```
NSlookup <DNS name>
```

The output will look similar to the following:

```
Server: hrnbtsjs-1.cisco.com
Address: 10.82.70.199
Name: mgcp-HRN11CA.hrndevtest.cisco.com
Addresses: 10.0.5.136, 10.128.1.147
```

The BTS configured local IP addresses are given in the `Addresses:` line.

- b. Determine the ITP configured values of the ITP BTS IP addresses and port.
- Log on to the ITP and get into enable mode.
  - Enter the following command:

```
show run
```

- Hit enter until the ASP configurations are displayed. A section similar to the following will appear which shows you the ITP configured values for the BTS IP addresses of the SCTP association:

```
cs7 asp hrn11asp 11146 2905 m3ua
remote-ip 10.0.5.136
remote-ip 10.128.1.147
```

The number after the ASP name "hrn11asp" is the port number that the ITP has configured for the BTS side of the SCTP association. The two remote-ip addresses are the addresses that the ITP has configured for the BTS side of the SCTP association. Make sure all of these values match the values found in Step 2A.

- Determine the BTS configured values for the ITP IP addresses and port

On the BTS EMS CLI console, type the following:

**CLI> show sctp-assoc id=<SCTP assoc id>**

An example of the output will show the IP addresses and port as follows:

```
REMOTE_PORT=2905
REMOTE_TSAP_ADDR1=10.0.1.54
REMOTE_TSAP_ADDR2=10.128.1.239
```

- Determine the ITP configured values of the ITP BTS IP addresses and port

- Logon to the ITP and get into enable mode.
- Enter **sho run**.
- Hit enter until the m3ua (or sua) configuration is displayed. In our example, we are considering the SCTP association connection between the BTS 10200 Softswitch and the ITP, so we will look at the ITP m3ua configuration. An example of this is as follows:

```
cs7 m3ua 2905
local-ip 10.0.1.54
local-ip 10.128.1.239
```

- Make sure that the IP addresses and port number are the same values as found in step 2C.

**Step 3** Determine if all Ethernet connections on the BTS have been disconnected or if communication has been lost to the IP router. In the platform log, look for the following ERROR message:

"All the IP interfaces are faulty!!"

If this message is found, the Ethernet connections of the BTS have been pulled or cut. If this message is not found, proceed to Step 4.



**Note**

Platform log is the log file found under /opt/optical/CA146/bin/logs. It is not a single log file.

**Step 4** Determine if the problem is an IP routing issue.

- Determine what has been provisioned in the BTS for the destination IP interfaces of the SCTP association by typing the following command:

```
show sctp-association id=<sctp-association-id>
```

Information similar to the following will appear and display the destination IP addresses:

```
REMOTE_TSAP_ADDR1=10.0.1.54
REMOTE_TSAP_ADDR2=10.128.1.239
```

- b. Ping each of the destination IP addresses. If one of the addresses does not respond to the ping, there is an IP routing problem that has disabled SCTP communication. Contact the Cisco TAC for assistance. If the ping commands are successful, proceed to Step 5.

**Step 5** Determine if the BTS is reachable from the ITP.

- a. Log on to the ITP and get into enable mode.
- b. Find the BTS SCTP association endpoint IP addresses by typing the following command:

**show run**

- c. Hit enter until the ASP configuration is displayed. A section similar to the following will display the BTS IP addresses of the SCTP association:

```
cs7 asp hrn11asp 11146 2905 m3ua
remote-ip 10.0.5.136
remote-ip 10.128.1.147
```

- d. From the ITP prompt, ping each of the IP addresses. If you do not receive a response to the ping command for at least one of the BTS IP endpoint addresses, there is an IP routing problem that is causing the SCTP association to be down. Contact the Cisco TAC for assistance. Otherwise, proceed to Step 6.

**Step 6** Bounce the SCTP association ( take it administratively out of service and then put it in service)

- a. At the BTS CLI prompt, enter the following commands:

```
control sctp-assoc id=<sctp-assoc-name>; mode=forced; target-state=OOS;
control sctp-assoc id=<sctp-assoc-name>; mode=forced; target-state=INS;
```

- b. Check if the SCTP association has come back in service by entering the following:

```
status sctp-assoc id=<sctp-assoc-name>;
```

The output will either show OPER STATE -> SCTP-ASSOC out of service or OPER STATE -> SCTP-ASSOC in service.

If the OPER STATE still shows that the SCTP association is out-of-service, proceed to Step 7.

**Step 7** Bounce the SCTP association from the ITP side by performing the following steps:

- a. Log on to the ITP and get into enable mode.
- b. Get into configure mode by typing configure terminal.
- c. Type the following commands to bounce the SCTP association back in service:

```
va-2651-82(config)#cs7 asp hrn11asp
va-2651-82(config-cs7-asp)#shut
va-2651-82(config-cs7-asp)#no shut
va-2651-82(config-cs7-asp)#end
```

- d. Determine if the SCTP association has come back in service by typing the following BTS CLI command:

```
status sctp-assoc id=<sctp-assoc-name>;
```

The output will display either OPER STATE -> SCTP-ASSOC out of service or OPER STATE -> SCTP-ASSOC in service.

If the OPER STATE still shows that the SCTP association is out-of-service, there is probably an SCTP communication issue that must be debugged at the SCTP protocol level. Contact the Cisco TAC for assistance.

---

## Debugging SCTP Problems for TCAP/SCCP Applications

Refer to [Debugging Network Problems for TCAP/SCCP Applications, page 4-11](#) to determine the source of the problem at the SUA layer.

## SCTP Association Degraded

This alarm indicates that one of the two sides of the multi-homed SCTP connection is down. Communication still exists if the other side of the multi-homed connection is up. Refer to the [“SCTP Association Failure” section on page 4-6](#), or contact the Cisco TAC for assistance in resolving this issue.

## SCTP Association Configuration Error

This alarm indicates that there is a provisioning error keeping the BTS from properly configuring the SCTP association. Perform the following steps to resolve the problem:

- 
- Step 1** If the associated application is ISUP, look at the platform.log for error messages containing the string “MIM CFG.”
  - Step 2** Perform Step 2 of the [“SCTP Association Failure” section on page 4-6](#) to verify that your IP addresses and ports are properly configured on the BTS.
  - Step 3** Contact the Cisco TAC for assistance in resolving this issue.
- 

## M3UA Cannot Go Active

This alarm is raised at initial startup or during failover by the BTS node that is trying to go into platform Active mode. It occurs when this BTS node is unable to communicate properly with any SGs to tell them that all active call traffic should be routing towards the BTS. See the [“Signaling Gateway Process Is Out of Service” section on page 4-6](#) to determine why the BTS is unable to communicate with any of the ITPs at the M3UA layer. Refer to the [“Verify the SCTP Association Status” section on page 4-11](#) to determine why the BTS is unable to communicate with any of the ITPs at the SUA layer.

## M3UA Cannot Go Standby

This alarm is raised at initial startup or during failover by the BTS node that is trying to go into platform Standby mode. See the [“Signaling Gateway Process Is Out of Service” section on page 4-6](#) to determine why the BTS is unable to communicate with any of the SGs at the M3UA layer. See the [“Verify the SCTP Association Status” section on page 4-11](#) to determine why the BTS is unable to communicate with any of the ITPs at the SUA layer.

## TCAP Binding Failure

This alarm is raised when the TCAP layer does not have enough SAP to bind for the subsystem. Currently only 16 subsystems are allowed on the same platform. Check the Subsystem table to see if you have more than 16 subsystems on the same platform, FSPTC or FSAIN.

## Remote Subsystem Is Out Of Service

This alarm indicates the remote subsystem is out of service. Contact your SCP service provider for assistance.

# Debugging Network Problems for TCAP/SCCP Applications

Network failure issues can be caused by several problems. This section describes the procedures to locate the cause of the problem. These procedures describe an iterative process that must be performed in order. When a problem is found and resolved, perform the procedure again from the beginning.

This section describes how to perform the following procedures:

- [Verify the SCTP Association Status, page 4-11](#)
- [Verify the Configuration, page 4-12](#)
- [Verify the IP Routing, page 4-14](#)
- [Verify if the ASP is Used by Any AS, page 4-14](#)
- [Verify the ITP T1 Card Provisioning, page 4-14](#)
- [Verify the ITP MTP2 Serial Interface, page 4-14](#)
- [Verify the ITP-STP Linkset Status, page 4-15](#)
- [Verify the Cisco ITP Route, page 4-16](#)

## Verify the SCTP Association Status

- Step 1** Determine if the administrative state and the operational state of the SCTP association on the BTS EMS are in service. If the SCTP association is not in service, bring it in service and repeat this step. The following is an example of a healthy SCTP association:

```
CLI>status sctp-assoc id=sctp_assoc3

SCTP ASSOC ID -> sctp_assoc3
ADMIN STATE -> ADMIN_INS
OPER STATE -> SCTP-ASSOC in service
REASON -> ADM executed successfully
RESULT -> ADM configure result in success
```

Reply : Success:

- Step 2** Determine if the ASP is in service on the Cisco ITP by entering show cs7 asp name <asp-name>. The ASP name corresponds to the SCTP association name provisioned on the BTS. Information similar to the following is displayed:

```
c2651-48#show cs7 asp name TB2-PRI-AIN
```

Effect Primary

| ASP Name    | AS Name      | State    | Type | Rmt Port | Remote IP Addr | SCTP |
|-------------|--------------|----------|------|----------|----------------|------|
| TB2-PRI-AIN | TB02-LNP-NC  | active   | SUA  | 12520    | 10.89.225.209  | 323  |
| TB2-PRI-AIN | TB02-SUALNP  | shutdown | SUA  | 12520    | 10.89.225.209  | 323  |
| TB2-PRI-AIN | TB02-800A-NC | active   | SUA  | 12520    | 10.89.225.209  | 323  |
| TB2-PRI-AIN | TB02-800T-NC | active   | SUA  | 12520    | 10.89.225.209  | 323  |
| TB2-PRI-AIN | TB02-SUA800A | active   | SUA  | 12520    | 10.89.225.209  | 323  |
| TB2-PRI-AIN | TB02-SUA800T | active   | SUA  | 12520    | 10.89.225.209  | 323  |

- a. If the status is shutdown, enter the following commands on the ITP and check the status again:

```
config terminal
cs7 asp <asp name>
no shut
```

- b. If the status of the ASP is inactive, the ASP is probably on the standby BTS.

- c. If the ASP on the active BTS is inactive, enter the following commands on the ITP and check the status again:

```
config terminal
cs7 asp <asp-name>
no shut
```

- d. If the ASP is now active, proceed to the “Verify if the ASP is Used by Any AS” section on page 4-14. Otherwise, continue to the next section.

## Verify the Configuration

**Step 1** Determine if the problem is an IP address or port configuration mismatch between the ITP and the BTS. Enter **show sctp-assoc id-<sctp-assoc-name>** on the BTS EMS

**Step 2** Enter **show cs7 sua** on the ITP.

**Step 3** Verify that the remote TSAP address and the remote port of the SCTP association on the BTS is the same as the local IP address and the local port used by the ITP SUA. If the SCTP association is multi-homed, all of the IP addresses should be verified. The following example displays properly matched configurations:

```
CLI>show sctp-assoc id=sctp_assoc3
```

```
ID=sctp_assoc3
SGP_ID=itp_2651_1
SCTP_ASSOC_PROFILE_ID=sctp_prof
REMOTE_PORT=14001
REMOTE_TSAP_ADDR1=10.89.232.48
PLATFORM_ID=FSAIN520
IP_TOS_PRECEDENCE=FLASH
LOCAL_RCVWIN=64000
MAX_INIT_RETRANS=5
MAX_INIT_RTO=1000
STATUS=INS
ULP=XUA
```

```
Reply : Success: Entry 1 of 1 returned.
```

```
c2651-48#show cs7 sua
Sigtran SUA draft version: 14
```

```
SUA Local port: 14001 State: active SCTP instance handle: 2
Local ip address: 10.89.232.48
Number of active SUA peers: 8
```

```

Max number of inbound streams allowed: 17
Local receive window: 64000
Max init retransmissions: 8
Max init timeout: 1000 ms
Unordered priority: equal
SCTP defaults for new associations
 Transmit queue depth: 1000 Cumulative sack timeout: 200 ms
 Assoc retransmissions: 10 Path retransmissions: 4
 Minimum RTO: 1000 ms Maximum RTO: 1000 ms
 Bundle status: on Bundle timeout: 400 ms
 Keep alive status: true Keep alive timeout: 10000 ms

```

**Step 4** If there is no mismatch, proceed to Step 5. Otherwise, perform the following procedure:

- a. Correct the mismatch.
- b. Bounce the SCTP association on the BTS.
- c. Repeat the “[Verify the SCTP Association Status](#)” section on page 4-11.

**Step 5** Verify that the SCTP port on the BTS and the remote port of the ASP on the ITP are the same.

- a. On the BTS, open the platform.cfg file and locate the section for TSA on FSAIN/FSPTC, as illustrated in the following example:

```

[ProcessParameters]
ProcName=TSA
#----- Process priority (valid values = -60 to 60)
-----#
Priority=24
#----- Max thread priority (valid values = -60 to 60)
-----#
MaxDynamicThreadPriority=18
#-----Resource limits = (max descriptors) / (max heap size bytes) / (max stack size
bytes)-----#
ResourceLimits=0 / 524288000 / 0
ExecName=tsa.FSAIN520
ExecPath=./
Args=-numthread 1 -tsadns crit-aSYS02AIN.ipclab.cisco.com -sctpport 12520 -stackcfg
tri_stack.cfg -multithread 0 -sgw_option SUA
ProcessGroup=0
ReportsDisableLevel=0
DebugReportsDisableLevel=0
NewConsole=0
Enable=1
ThreadHealthMonitoring=yes
SwitchOverIfMaxRestartExceededInDuplex=yes
EndPlatformIfMaxRestartExceededWhenMateFaulty=yes
#----- Restart rate = n /m (where n = Max restarts , m - interval in hours)
-----#
RestartRate=0 / 1
...

```

- b. On the ITP, enter **show run | begin <asp-name>**. Information similar to the following is displayed:

```

c2651-48#show run | begin TB2-PRI-AIN
cs7 asp TB2-PRI-AIN 12520 14001 sua
 remote-ip 10.89.225.209
 remote-ip 10.89.226.209
!

```

- c. If the sctp port on the BTS and the remote port of the ASP on the ITP are the same, proceed to Step 6.
- d. If the sctp port on the BTS and the remote port of the ASP on the ITP are not the same, perform the following procedure:
  - Correct the problem on the ITP

- Bounce the SCTP association on the BTS
  - Repeat the “Verify the SCTP Association Status” section on page 4-11.
- Step 6** Verify that the tsadns resolves to exactly the same remote-ip as the ASP on the ITP. If not, perform the following procedures as necessary:
- a. Correct it in the /etc/hosts file and on the DNS server, if necessary.
  - b. Correct it on the ITP if the IP addresses on the ITP are incorrect.
  - c. Bounce the SCTP association on the BTS.
  - d. Repeat the “Verify the SCTP Association Status” section on page 4-11.

## Verify the IP Routing

- Step 1** Ping the ITP addresses discovered in the “Verify the Configuration” section on page 4-12 from the BTS in order to see if traffic is routed as planned.
- Step 2** Ping the BTS addresses discovered in the “Verify the Configuration” section on page 4-12 from the ITP to see if traffic is routed as planned.
- Step 3** If routing is not as expected, correct the routing setup.
- Step 4** Repeat the “Verify the SCTP Association Status” section on page 4-11.

## Verify if the ASP is Used by Any AS

If the ASP is not used by any AS in the ITP, the SCTP association will be taken down by the ITP. Make sure the AS using the ASP is provisioned before bringing up the SCTP association corresponding to the same ASP. If the ASP is used by any AS, continue to the next section. Otherwise, correct it and continue

## Verify the ITP T1 Card Provisioning

Enter **show controller t1 <slot/[bay/]port>** on the ITP. Verify if T1 is up. If not, check if the framing, line code, and the clock source are provisioned as planned. The following example displays a healthy card status:

```
c2651-48#show controllers t1 0/0

T1 0/0 is up.
 Applique type is Channelized T1
 Cablelength is short 133
 No alarms detected.
 alarm-trigger is not set
 Version info Firmware: 20010805, FPGA: 15
 Framing is ESF, Line Code is B8ZS, Clock Source is Line.
 Data in current interval (477 seconds elapsed):
 0 Line Code Violations, 0 Path Code Violations
 0 Slip Secs, 0 Fr Loss Secs, 0 Line Err Secs, 0 Degraded Mins
 0 Errored Secs, 0 Bursty Err Secs, 0 Severely Err Secs, 0 Unavail Secs
.....
```

## Verify the ITP MTP2 Serial Interface

To resolve problems with the ITP MTP2 serial interface, perform the following steps:

- Step 1** To display the state of the ITP MTP2 serial interface, enter **show int serial <number>** on the ITP. Information similar to the following will be displayed:

```
c2651-48#show int serial 0/0:0

Serial0/0:0 is up, line protocol is up
 Hardware is PowerQUICC Serial
 Description: link_to_mgts_lic_10
 MTU 1500 bytes, BW 56 Kbit, DLY 20000 usec,
 reliability 255/255, txload 1/255, rxload 1/255
 Encapsulation SS7 MTP2, loopback not set
 Keepalive not set
 Last input 33w5d, output 00:00:31, output hang never
 Last clearing of "show interface" counters 33w5d
 Queueing strategy: fifo
 Output queue 0/40, 0 drops; input queue 0/75, 23 drops
 30 second input rate 0 bits/sec, 0 packets/sec
 30 second output rate 0 bits/sec, 0 packets/sec
 1912000 packets input, 9866017 bytes, 0 no buffer
 Received 0 broadcasts, 0 runts, 17 giants, 0 throttles
 3356 input errors, 128 CRC, 2641 frame, 0 overrun, 0 ignored, 587 abort
 1163961 packets output, 13234709 bytes, 0 underruns
 0 output errors, 0 collisions, 55 interface resets
 0 output buffer failures, 0 output buffers swapped out
 31 carrier transitions
 Timeslot(s) Used:1, SCC: 0, Transmitter delay is 0 flags
```

- Step 2** If the interface is up and the line protocol is up, continue to the next section. If there is a problem, determine where the problem exists, as follows:
- If the interface is down, shut down the interface manually.
  - If the line protocol is down, the problem exists in cabling or in the MTP2 layer.
  - If both the interface and the line protocol are down, there is a hardware failure or the interface is manually shutdown.
- Step 3** After correcting the problem, continue to the next section.

## Verify the ITP-STP Linkset Status

To resolve problems with the ITP-STP linkset status, perform the following steps:

- Step 1** Verify whether the link-set is available on the ITP by entering the following command **show cs7 linkset <ls-name>**.

Information similar to the following is displayed:

```
c2651-48#show cs7 linkset
lsn=ls_to_mgts_lic_10 apc=1.101.0 state=avail avail/links=1/1
 SLC Interface Service PeerState Inhib
 00 Serial0/0:0 avail ----- ----
```

- Step 2** If the status is not available and at least one of the serial interfaces is available, the problem could be the point code type or point code value mismatch with the remote peer.

- Step 3** If the checking is successful, continue to the next section. Otherwise, correct the problem and continue.
- 

## Verify the Cisco ITP Route

To resolve problems with the Cisco ITP route, perform the following steps:

---

- Step 1** Verify if there is a route to the destination point code provisioned in the BTS by entering the following command:

```
show cs7 route
```

Information similar to the following is displayed:

```
c2651-48#show cs7 route
Dynamic Routes 0 of 500

Routing table = system Destinations = 6 Routes = 6

Destination Prio Linkset Name Route

1.8.1/24 INACC 1 ls_to_mgts_lic_10 UNAVAIL
1.12.1/24 acces 5 ls_to_mgts_lic_10 avail
1.101.0/24 acces 1 ls_to_mgts_lic_10 avail
7.44.120/24 acces 1 ls_to_inet12_pod_1 avail
7.44.121/24 acces 1 ls_to_inet12_pod_1 avail
7.212.112/24 acces 1 ls_to_inet12_pod_1 avail

Routing table = XUA

Destination Type

7.2.1/24 acces AS
7.2.3/24 acces AS
7.44.1/24 acces AS
7.44.3/24 acces AS
```

- Step 2** If the linkset is available and the route is UNAVAIL, the problem could be in the service provider's SS7 network. Contact the service provider to coordinate troubleshooting.

After successfully passing this step, the network failure should not happen. If it still happens, the supporting team or the developer should be contacted.

## Troubleshooting With the Query Command

The Query Verification Tool (QVT) enables a user to generate TCAP queries to external databases through the CLI interface. For information about the QVT, see the following URL:

[http://www.cisco.com/univercd/cc/td/doc/product/voice/bts10200/bts4\\_4/featmods/qvttvt.htm#wp1168709](http://www.cisco.com/univercd/cc/td/doc/product/voice/bts10200/bts4_4/featmods/qvttvt.htm#wp1168709)

## Table Configuration Problems

The CLI query command with the table-info option displays the tables used for routing the external SS7 queries on the BTS. The query command can identify the following problems:

- Missing CA-CONFIG table
- Missing SLHR-PROFILE table
- Missing SLHR table
- Missing DPC table
- Missing OPC table
- Missing SUBSYSTEM-PROFILE table
- Missing SUBSYSTEM table
- Missing SCCP-NW table
- Missing SCCP-ROUTE table
- Missing ROUTING-KEY table
- Missing SG-GRP table
- Missing SG table
- Missing SGP table
- Missing SCTP-ASSOC table

To resolve a table error, add the appropriate entry to the table specified in the command response.

## Network Related Problems

The CLI query command can provide information about network related problems. This section describes problems identified by the query command and the solutions to them.

### No Translation for an Address of Such Nature

|          |                                                        |
|----------|--------------------------------------------------------|
| Layer    | SCCP                                                   |
| Version  | ITU88, ITU92, ITU96, ANSI88, ANSI92                    |
| Location | STP                                                    |
| Cause    | The GTT entry is not provisioned correctly in the STP. |
| Solution | Correct the GTT entry in the STP.                      |

## No Translation for this Specific Address

|          |                                                        |
|----------|--------------------------------------------------------|
| Layer    | SCCP                                                   |
| Version  | ITU88, ITU92, ITU96, ANSI88, ANSI92                    |
| Location | STP                                                    |
| Cause    | The GTT entry is not provisioned correctly in the STP. |
| Solution | Add the GTT entry in the STP.                          |

## Subsystem Congestion

|          |                                                              |
|----------|--------------------------------------------------------------|
| Layer    | SCCP Subsystem (TCAP)                                        |
| Version  | ITU88, ITU92, ITU96, ANSI88, ANSI92                          |
| Location | SCP                                                          |
| Cause    | The SCP subsystem is congested.                              |
| Solution | Ask the SCP Service Provider to solve the congestion problem |

## Subsystem Failure

|          |                                                      |
|----------|------------------------------------------------------|
| Layer    | SCCP Subsystem (TCAP)                                |
| Version  | ITU88, ITU92, ITU96, ANSI88, ANSI92                  |
| Location | SCP                                                  |
| Cause    | The SCP is down or the subsystem of the SCP is down. |
| Solution | Verify that the SCP point code is correct.           |

## Unequipped User

|         |                                     |
|---------|-------------------------------------|
| Layer   | SCCP Subsystem (TCAP)               |
| Version | ITU88, ITU92, ITU96, ANSI88, ANSI92 |

|          |                                           |
|----------|-------------------------------------------|
| Location | SCP                                       |
| Cause    | The SCCP user is not equipped             |
| Solution | Verify that the SCP point code is correct |

## Network Failure

|          |                                                                                                                               |
|----------|-------------------------------------------------------------------------------------------------------------------------------|
| Layer    | MTP3/MTP2/MTP1 or SCTP                                                                                                        |
| Version  | ITU88, ITU92, ITU96, ANSI88, ANSI92 for MTP3/2/1, IETF RFC 2960 for SCTP                                                      |
| Location | Local, STP, or SCP                                                                                                            |
| Cause    | The BTS-ITP sctp-association is down or the SS7 link, linkset, or route is down.                                              |
| Solution | See the <a href="#">Debugging Network Problems for TCAP/SCCP Applications</a> section for assistance in solving this problem. |

## Network Congestion

|          |                                                                                                                                                                                                                                                              |
|----------|--------------------------------------------------------------------------------------------------------------------------------------------------------------------------------------------------------------------------------------------------------------|
| Layer    | SCCP                                                                                                                                                                                                                                                         |
| Version  | ITU88, ITU92, ITU96, ANSI88, ANSI92                                                                                                                                                                                                                          |
| Location | Local, STP, or SCP                                                                                                                                                                                                                                           |
| Cause    | The SCTP layer or the SS7 network is congested.                                                                                                                                                                                                              |
| Solution | The service provider of the SS7 network needs to either provide higher capacity or re-engineer the traffic. SCTP layer congestion normally indicates insufficient CPU power. Hardware needs to be upgraded or more BTSs need to be added to offload traffic. |

## Unqualified

|          |                                     |
|----------|-------------------------------------|
| Layer    | SCCP                                |
| Version  | ITU88, ITU92, ITU96, ANSI88, ANSI92 |
| Location | STP or SCP                          |

|          |                                                       |
|----------|-------------------------------------------------------|
| Cause    | Unknown.                                              |
| Solution | Contact the support team or developer for assistance. |

## Error In Message Transport

|          |                                                |
|----------|------------------------------------------------|
| Layer    | SCCP                                           |
| Version  | ITU92                                          |
| Location | STP                                            |
| Cause    | There was a failure in message transportation. |
| Solution | Contact the support team or the developer.     |

## Destination Cannot Perform Reassembly

|          |                                                                                             |
|----------|---------------------------------------------------------------------------------------------|
| Layer    | SCCP                                                                                        |
| Version  | ITU88, ITU92, ITU96, ANSI88, ANSI92                                                         |
| Location | SCP                                                                                         |
| Cause    | The peer side is not capable of reassembling XUDTS packets.                                 |
| Solution | The ITP does not support segmentation and reassembly. Contact the Cisco TAC for assistance. |

## SCCP Failure

|          |                                                                                                                                                    |
|----------|----------------------------------------------------------------------------------------------------------------------------------------------------|
| Layer    | SCCP                                                                                                                                               |
| Version  | ITU88, ITU92, ITU96, ANSI88, ANSI92                                                                                                                |
| Location | Local, STP, or SCP                                                                                                                                 |
| Cause    | The SCCP layer failed or the local TSA could not find the appropriate entry in the Subsystem table or the SCCP-nw table.                           |
| Solution | Add or properly populate the Subsystem and SCCP-nw tables. If it still does not work, restart the platform providing the service (FSAIN or FSPTC). |

## Hop Counter Violation

|          |                                                                                                                                                      |
|----------|------------------------------------------------------------------------------------------------------------------------------------------------------|
| Layer    | SCCP                                                                                                                                                 |
| Version  | ITU96, ANSI92                                                                                                                                        |
| Location | STP                                                                                                                                                  |
| Cause    | The maximum hop count is exceeded during the message routing.                                                                                        |
| Solution | Make sure the hop count value provisioned in the SCCP-NW table is not too small. Verify that the SS7 network provider does not have any route-loops. |

## Segmentation Not Supported

|          |                                                                                             |
|----------|---------------------------------------------------------------------------------------------|
| Layer    | SCCP                                                                                        |
| Version  | ITU96                                                                                       |
| Location | SCP                                                                                         |
| Cause    | The peer side is not capable of reassembling XUDTS packets.                                 |
| Solution | The ITP does not support segmentation and reassembly. Contact the Cisco TAC for assistance. |

## Segmentation Failure

|          |                                                                                             |
|----------|---------------------------------------------------------------------------------------------|
| Layer    | SCCP                                                                                        |
| Version  | ITU96                                                                                       |
| Location | STP                                                                                         |
| Cause    | The segmentation failed.                                                                    |
| Solution | The ITP does not support segmentation and reassembly. Contact the Cisco TAC for assistance. |

## QVT Timeout

|          |                                                                                                                                |
|----------|--------------------------------------------------------------------------------------------------------------------------------|
| Location | Local                                                                                                                          |
| Cause    | The SCP failed to respond or the TSA is out of service.                                                                        |
| Solution | If the SCP failed, contact the service provider to solve the problem. If the TSA is out of service, perform a manual failover. |

## CLI Timeout

|          |                                                                                                                                                                                                              |
|----------|--------------------------------------------------------------------------------------------------------------------------------------------------------------------------------------------------------------|
| Location | Local                                                                                                                                                                                                        |
| Cause    | The EMS and CA.FSAIN/FSPTC connection is down or the SCA on the CA/FSAIN/FSPTC is out of service.                                                                                                            |
| Solution | If the SCA is down, restart the SCA or restart the platform where the SCA resides. If the EMS and CA/FSAIN/FSPTC connection is down, verify whether the IP routing is correct and the OMS hub is in service. |

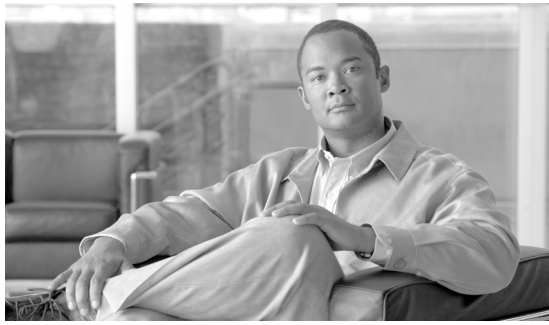

## GLOSSARY

### A

- ACAR** Automatic Callback and Automatic Recall
- AIN** Advanced Intelligent Network
- AS** Application Server; an M3UA term that describes software that processes M3UA messages. The SGA.
- ASP** Application Server Process; defines the IP interfaces to which the SG sends M3UA traffic.

### B

- BTS Shared Point Code Configuration** A configuration in which a Cisco BTS 10200 Softswitch OPC and the SG with which it connects share the same SS7 point code (OPC) value. In this configuration, the SG connects directly to an STP via SS7 A-links, F-links, or E-links.
- BTS Mated STP Pair Configuration** A configuration in which the Cisco BTS 10200 Softswitch and the SG with which it connects do not share the same SS7 point code (OPC) value. In this configuration, the SGs operate as STPs.

### C

- CA** Call Agent.
- Cisco BTS 10200 Softswitch** Cisco BTS 10200 Softswitch Active/Standby mated pair.
- CNAM** Calling name delivery.

### D

- DAVA** M3UA Destination Available message.
- Distributed MTP3** An M3UA term describing a signaling network topology in which two or more physical SGP nodes operate as a single SG node, thereby providing hardware redundancy.
- DUNA** M3UA Destination Unavailable message.
- DUPU** M3UA Destination User Part Unavailable message.

**E**

**EMS** Element Management System.

**F**

**FS** BTS Feature Server

**FSAIN** BTS Feature Server for AIN services such as LNP and 800 services.

**FSPTC** BTS Feature Server for POTS and Centrex services such as ACAR and CNAM.

**G**

**GTT** Global Title Translation.

**H**

**I**

**ITP** Cisco IP Transfer Point. This is the SGP that is used in combination with the Cisco BTS 10200 Softswitch to form the Sigtran signaling solution.

**J**

**K**

**L**

**M**

**M3UA** MTP3 User Adaptation Layer.

**MIM** M3UA interface Module

**MTP3** Message Transfer Part Level 3.

**N**

**NMS** Network Management System.

**NSO** Non-Stop Operation.

**O****P****Q****R**

**Routing Context** A value that uniquely identifies a Routing Key.

**Routing Key** A set of SS7 parameters, such as DPC, OPC, SI, CIC-range, and SSN, that uniquely define the range of signaling traffic to be handled by a particular AS..

**S**

**SCON** M3UA Signaling Congestion message.

**SCCP** Signaling Connection Control Part

**SCTP** Stream Control Transmission Protocol. IETF standard for reliable transport over IP. Used instead of TCP/UDP/RUDP.

**SEP** Signaling End Point.

**SG Group** A Cisco BTS term that describes the pairing of SGs to form redundancy for the Cisco BTS 10200 Softswitch D-link solution. An equivalent ITP term that describes this pairing is SG Mated Pair.

**SG Mated Pair** An ITP term that describes the pairing of SGs to form redundancy for the Cisco BTS 10200 Softswitch D-link solution. An equivalent Cisco BTS term that describes this pairing is SG Group.

**Signaling Gateway** A logical gateway that interconnects IP signaling over Sigtran to SS7 Network signaling over SS7 (T1/E1) links. It can be made up of one or more signaling gateway processes. The solution described in this document allows a maximum of two SGPs (ITPs) to be combined to form a single SG.

**Signaling Gateway Process** A physical gateway that interconnects IP signaling over Sigtran to SS7 Network signaling over SS7 (T1/E1) links. One or more SGPs can be combined to form a single SG. The solution described in this document allows a maximum of two SGPs (ITPs) to be combined to form a single SG.

|                |                                                                                                                                                        |
|----------------|--------------------------------------------------------------------------------------------------------------------------------------------------------|
| <b>Sigtran</b> | A group of IETF standards that describe the SS7 signaling functionality of hardware nodes that interconnect IP based networks to SS7 Network networks. |
| <b>SGA</b>     | Signaling Gateway Adapter. A process on the Cisco BTS 10200 Softswitch that processes ISUP related calls.                                              |
| <b>SGP</b>     | Signaling Gateway Process.                                                                                                                             |
| <b>STP</b>     | Signaling Transfer Point.                                                                                                                              |
| <b>SUA</b>     | SCCP User Adaptation Layer.                                                                                                                            |

**T**

|             |                                                                                                      |
|-------------|------------------------------------------------------------------------------------------------------|
| <b>TCAP</b> | Transaction Capability Application Part                                                              |
| <b>TFA</b>  | MTP3 Transfer Allowed message..                                                                      |
| <b>TFC</b>  | MTP3 Transfer Control message. MTP3message for congestion indications.                               |
| <b>TFP</b>  | MTP3 Transfer Prohibit message.                                                                      |
| <b>TSA</b>  | TCAP Service Adapter. A process on the Cisco BTS 10200 Softswitch that processes TCAP related calls. |

**U****V****W****X****Y****Z**

---

## Numerics

800 Services [2-2](#)

---

## A

Additional Publications, Obtaining [ix](#)

Alarms [4-4](#)

A link,

    NSO configuration [1-10](#)

    shared point code configuration [1-6](#)

automatic recall (ACAR) [2-2](#)

---

## B

BTS1 Provisioning [3-18, 3-22](#)

BTS2 Provisioning [3-19, 3-22](#)

---

## C

calling name delivery (CNAM) [2-2](#)

CD-ROM, Documentation [vi](#)

Cisco

    BTS10200 Provisioning [3-22](#)

    BTS 10200 Softswitch Configuration [2-6, 3-5, 3-11](#)

    ITP Configuration [3-17, 3-21](#)

    ITP Route, Verifying [4-16](#)

    Press [ix](#)

    Product Catalog [ix](#)

    TAC Website [viii](#)

Cisco.com [vi, vii](#)

CLI

    Commands [4-3](#)

    Timeout [4-22](#)

Configuration,

    Cisco BTS 10200 Softswitch [2-6, 3-11](#)

    Cisco ITP [3-17, 3-21](#)

    GTT [2-5](#)

    ITP [2-3, 3-2, 3-10](#)

    ITP AS and ASP [2-1](#)

    Mated STP-Pair [1-5, 2-6](#)

    Shared Point Code [1-6](#)

    Verifying [4-12](#)

Congestion, Subsystem [4-18](#)

Controlling ITP Resources [4-2](#)

---

## D

Destination Cannot Perform Reassembly [4-20](#)

D link,

    NSO configuration [1-9](#)

    NSO configuration example ISUP with ASP load share [2-31](#)

    NSO configuration example TCAP with ASP load share [2-32](#)

Documentation

    CD-ROM [vi](#)

    Feedback [vii](#)

Documentation,

    Obtaining [vi](#)

    Ordering [vi](#)

Document Change History [ix](#)

DPC Congested [4-5](#)

DPC Unavailable [4-5](#)

DPC User Part Unavailable [4-5](#)

---

## E

E link,

    shared point code configuration [1-7](#)

Error In Message Transport [4-20](#)

---

## F

Failure, Subsystem [4-18](#)

Feature History [v](#)

Feedback [vii](#)

F link,  
 NSO configuration [1-10](#)  
 shared point code configuration [1-8](#)

---

## G

GTT [3-1, 4-17, 4-18](#)  
 GTT Configuration [2-5](#)

---

## H

Hardware Redundancy [1-2](#)  
 high capacity traffic [3-1](#)  
 History, Feature [v](#)  
 Hop Counter Violation [4-21](#)

---

## I

If the ASP is Used by Any AS, Verifying [4-14](#)  
 Information, Obtaining [ix](#)  
 Internet Protocol Journal [ix](#)  
 IP Routing, Verifying [4-14](#)  
 iQ Magazine [ix](#)  
 ISUP Applications [4-6](#)  
 ITP  
   AS and ASP Configuration [2-1](#)  
   Configuration [2-3, 3-2, 3-10](#)  
   MTP2 Serial Interface, Verifying [4-14](#)  
   Redundancy [1-2](#)  
   Resources, Controlling [4-2](#)  
   Status Commands [4-2](#)  
   System Messages [4-1](#)  
   T1 Card Provisioning, Verifying [4-14](#)  
   Troubleshooting Procedures [4-1](#)  
 ITP,  
   Logging on [4-2](#)  
   Viewing configuration [4-2](#)  
 ITP-Group [1-4](#)

ITP-STP Linkset Status, Verifying [4-15](#)

---

## L

LNP [2-2](#)  
 Logs [4-3](#)

---

## M

M3UA Cannot Go Active [4-10](#)  
 M3UA Cannot Go Standby [4-10](#)  
 Mated STP-Pair [3-1, 3-8, 3-10, 3-20](#)  
 Mated STP-Pair Configuration [1-5, 2-6](#)

---

## N

Network  
   Congestion [4-19](#)  
   Failure [4-19](#)  
 NSO (Non Stop Operation),  
   redundancy [1-3](#)

---

## O

Obtaining  
   Additional Publications and Information [ix](#)  
   Documentation [vi](#)  
   Technical Assistance [vii](#)  
 Ordering Documentation [vi](#)  
 Overlapping AS Configurations [2-4](#)

---

## P

Packet magazine [ix](#)  
 Platform Redundancy [1-2](#)  
 Profiles, Customer [3-1](#)  
 Provisioning,  
   BTS1 [3-18, 3-22](#)

BTS2 [3-19, 3-22](#)

SCTP [2-2](#)

---

## Q

Query Command [4-16](#)

Query Verification Tool [4-16](#)

QVT [4-16](#)

QVT Timeout [4-22](#)

---

## R

Reassembly, Destination Cannot Perform [4-20](#)

Redundancy [1-2](#)

Redundancy,

    Hardware [1-2](#)

    ITP [1-2](#)

    Platform [1-2](#)

Related Documents [v](#)

Remote Subsystem Is Out Of Service [4-11](#)

---

## S

SCCP Failure [4-20](#)

SCTP

    Provisioning [2-2](#)

SCTP Association

    Configuration Error [4-10](#)

    Degraded [4-10](#)

    Failure [4-6](#)

    Status, Verifying [4-11](#)

Segmentation Failure [4-21](#)

Segmentation Not Supported [4-21](#)

SG Mated Pair [1-3](#)

SG Priority Routing [3-20](#)

Shared Point Code [3-1, 3-10](#)

    Configuration [1-6, 1-7](#)

Signaling Gateway

Failure [4-6](#)

Group Is Out of Service [4-6](#)

Process Is Out of Service [4-6](#)

Subscription Store [vi](#)

Subsystem Congestion [4-18](#)

Subsystem Failure [4-18](#)

---

## T

TAC Escalation Center [viii](#)

TCAP/SCCP Applications [4-10, 4-11](#)

TCAP Binding Failure [4-11](#)

Technical Assistance, Obtaining [vii](#)

Technical Assistance Center [vii](#)

Training [ix](#)

Troubleshooting [4-1, 4-4, 4-16](#)

Troubleshooting, Cisco BTS 10200 Softswitch [4-3](#)

---

## U

Unequipped User [4-18](#)

Unqualified [4-19](#)

