



## About Bridge Networking

---

The Cisco Unity Bridge acts as a networking gateway between Cisco Unity and Avaya Octel systems or Avaya Interchange, which are on an Octel analog network. With the Bridge, Cisco Unity subscribers can send messages to and receive messages from Octel subscribers.

This chapter explains how networking with the Bridge works, and describes the various Cisco Unity components involved with Bridge Networking. See the following sections for more information:

- [Overview of Bridge Networking, page 1-1](#)
- [Nodes on the Octel Analog Network, page 1-5](#)
- [Directory Information Sharing, page 1-9](#)
- [Maintaining the Logical Octel Network Topology Within the Cisco Unity Directory, page 1-12](#)
- [Message Addressing Options, page 1-14](#)
- [Blind Addressing and Bridge Networking, page 1-15](#)
- [Bridge Subscribers, page 1-16](#)
- [Supported Codecs, page 1-24](#)
- [Notable Behavior, page 1-25](#)
- [Additional Bridge-Related Documentation, page 1-28](#)

## Overview of Bridge Networking

The Cisco Unity Bridge acts as a networking gateway between Cisco Unity and Avaya Octel systems or Avaya Interchange on an Octel analog network. The Bridge server is connected to a phone system and communicates with Octel servers by using the Octel analog networking protocol. The Bridge server sends messages to Cisco Unity by using a digital protocol that is based on the Voice Profile for Internet Mail (VPIM) protocol, with proprietary extensions. The Bridge must be installed on a separate and dedicated platform, and it can communicate with up to 998 Octel servers. [Figure 1-1](#) depicts—at a high level—the role of the Bridge server.

**Figure 1-1** Bridge Communication Is Digital with Cisco Unity, and Analog with the Octel Servers

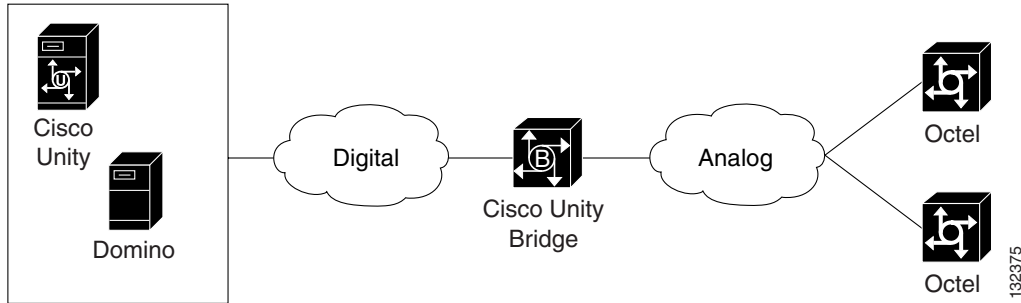

## Messaging Between the Bridge and Cisco Unity

Messaging between the Bridge and Cisco Unity is done over the Internet or any TCP/IP network by using SMTP. The Bridge sends messages to an SMTP server that you specify when configuring the Bridge server. (The SMTP server may be a Domino server or another server configured to relay SMTP messages.) The SMTP server then routes messages to Domino, which delivers messages to recipient mail files.

The Bridge server can be connected to the same LAN that Cisco Unity and Domino are connected to, as depicted in [Figure 1-2](#).

**Figure 1-2** Bridge Server Can Be on the Same LAN as Cisco Unity and Domino

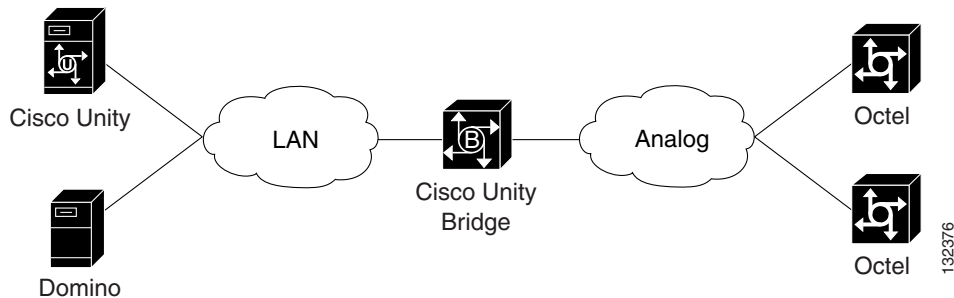

However, as [Figure 1-3](#) illustrates, the Bridge server can be located in a different location from Cisco Unity and Domino, in which case messages are sent through the Internet or a WAN.

**Figure 1-3** Bridge Server Can Be Located in a Different Location

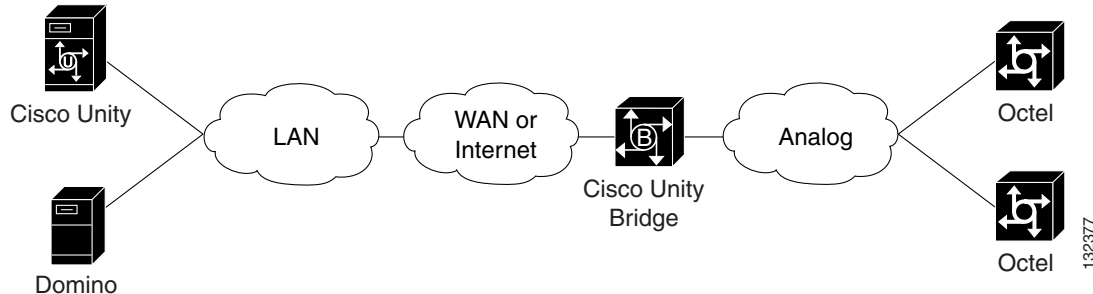

## Messaging Between the Bridge and Octel

Messaging between the Bridge and the Octel servers is done via Octel analog networking. The Bridge masquerades as one or more nodes on the Octel analog network. Voice messages are transmitted between nodes by using ordinary phone connections. When one node calls another by dialing a specified phone number, the originating node transmits a sequence of DTMF tones to identify itself as an Octel node. The destination node then transmits DTMF tones in reply. If the destination node accepts the call, the originating node transmits each voice message by using analog playback, and the destination node records each message and delivers it. To the Octel servers, the Bridge behaves like any other Octel node on the Octel analog network.

## Connecting the Bridge Server to the Phone System

The Bridge server needs to place phone calls to, and receive phone calls from, all Octel servers with which it will communicate. The Bridge server contains voice-fax cards that are connected to a phone system. The Bridge analog ports have no relation to the voice ports on the Cisco Unity system. In fact, the Bridge may or may not use the same phone system as Cisco Unity or the Octel servers. The only requirement for the Bridge ports is that they be provided with an analog dial tone from a source that allows connection to the phone number(s) of the Octel server(s) with which the Bridge will communicate. [Figure 1-4](#) illustrates some of the methods for providing analog connectivity to the Bridge server.

**Figure 1-4** Methods for Providing Analog Connectivity to the Bridge Server

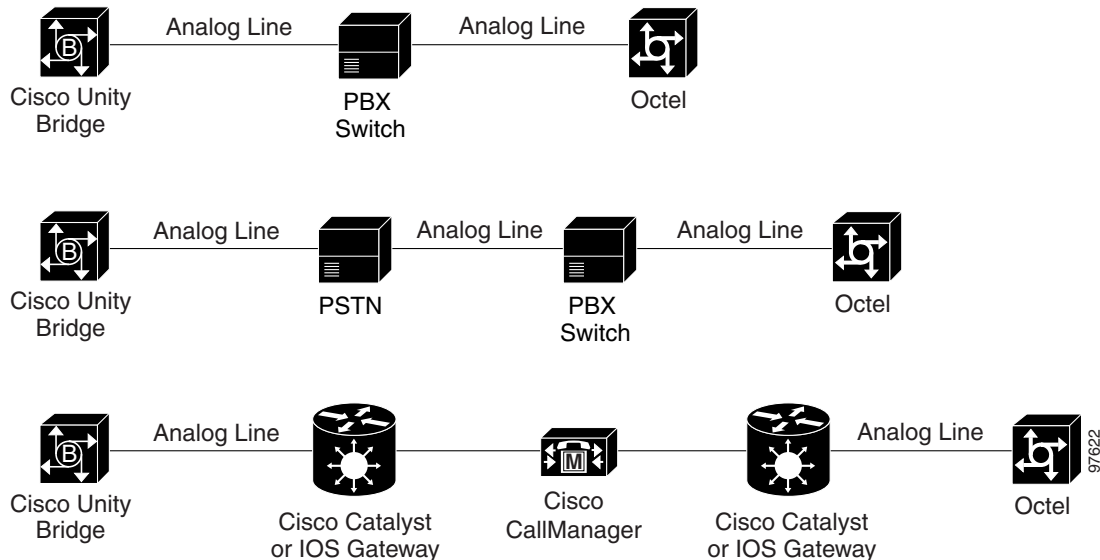

The voice-fax cards in the Bridge server are an FXO interface. If the Bridge will place and receive phone calls via a Cisco CallManager phone system, an FXS card in an IP gateway is required. Supported Cisco IP gateways for use with the Bridge are listed in the “Supported Cisco Gateways” section of the *Cisco Unity Bridge System Requirements, and Supported Hardware and Software*, available at [http://www.cisco.com/en/US/products/sw/voicesw/ps2237/prod\\_installation\\_guides\\_list.html](http://www.cisco.com/en/US/products/sw/voicesw/ps2237/prod_installation_guides_list.html).

The phone system to which the Bridge connects must be configured with a phone number, known as the pilot number, to direct inbound calls to any available line on the Bridge. When more than one Bridge is deployed, each Bridge must have its own pilot number.

## Bridgehead Server

In installations with multiple Cisco Unity servers digitally networked together, only one Cisco Unity server in the network needs to be configured for networking with the Bridge. This server acts as the “bridgehead” server for the other Cisco Unity servers in the network, as [Figure 1-5](#) illustrates. If allowed by the primary location addressing options, all subscribers, no matter which Cisco Unity server they are associated with, can send messages to Octel subscribers.

Figure 1-5 Cisco Unity Bridgehead Server

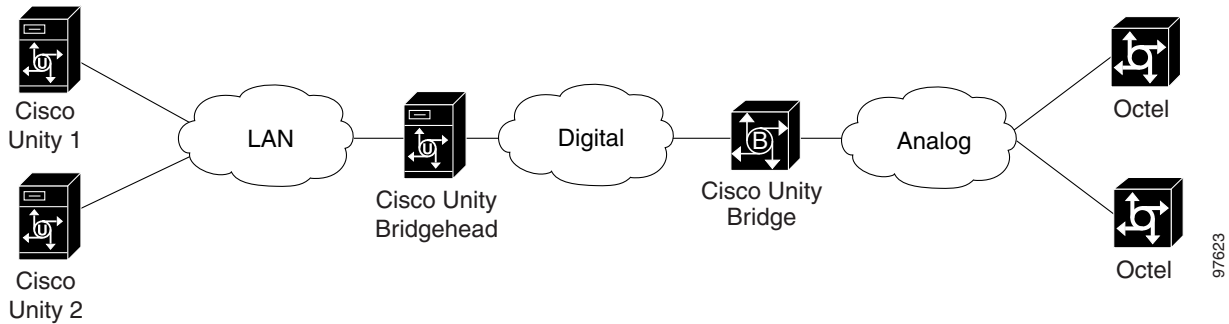

Because the analog transmission of messages to the Octel servers is much slower than digital transmission to Cisco Unity, the bridgehead server can be configured for networking with additional Bridge servers, as needed, to provide sufficient analog ports for messaging with the Octel servers.

For installations with more than one Bridge server, each Bridge server is configured for messaging with a subset of the Octel servers. For example, [Figure 1-6](#) illustrates an installation where Bridge 1 is configured for messaging with Octel 1 and Octel 2, and Bridge 2 is configured for messaging with Octel 3 and Octel 4.

Figure 1-6 One Bridgehead Server Can Communicate with Multiple Bridge Servers

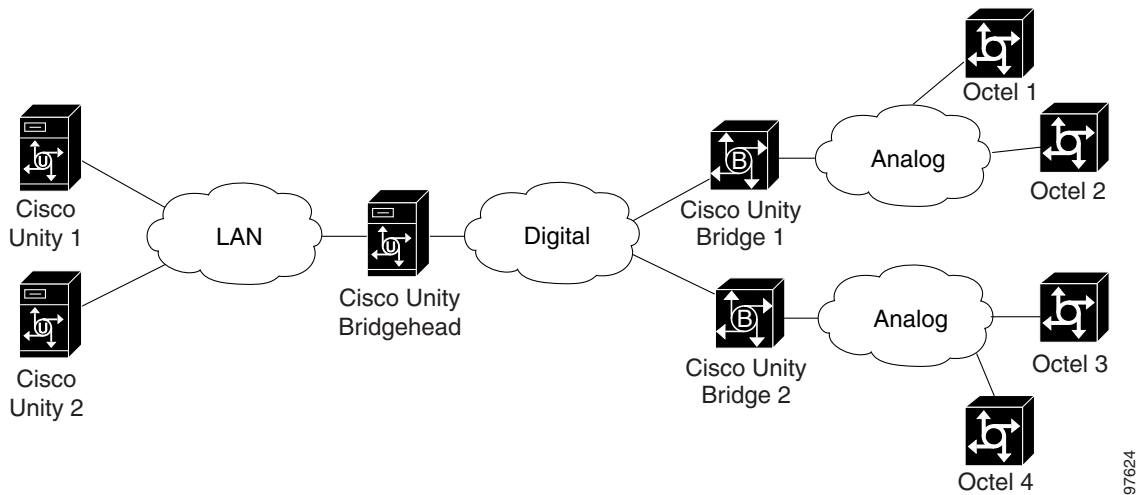

## Nodes on the Octel Analog Network

Each Octel server represents a node in the Octel analog network. In Octel analog networking, each node is assigned a unique serial number, which identifies the node. As [Figure 1-7](#) illustrates, each Octel server is configured with a node profile—which includes the serial number and phone number—for every other node in the network.

Figure 1-7 Octel Nodes in the Network

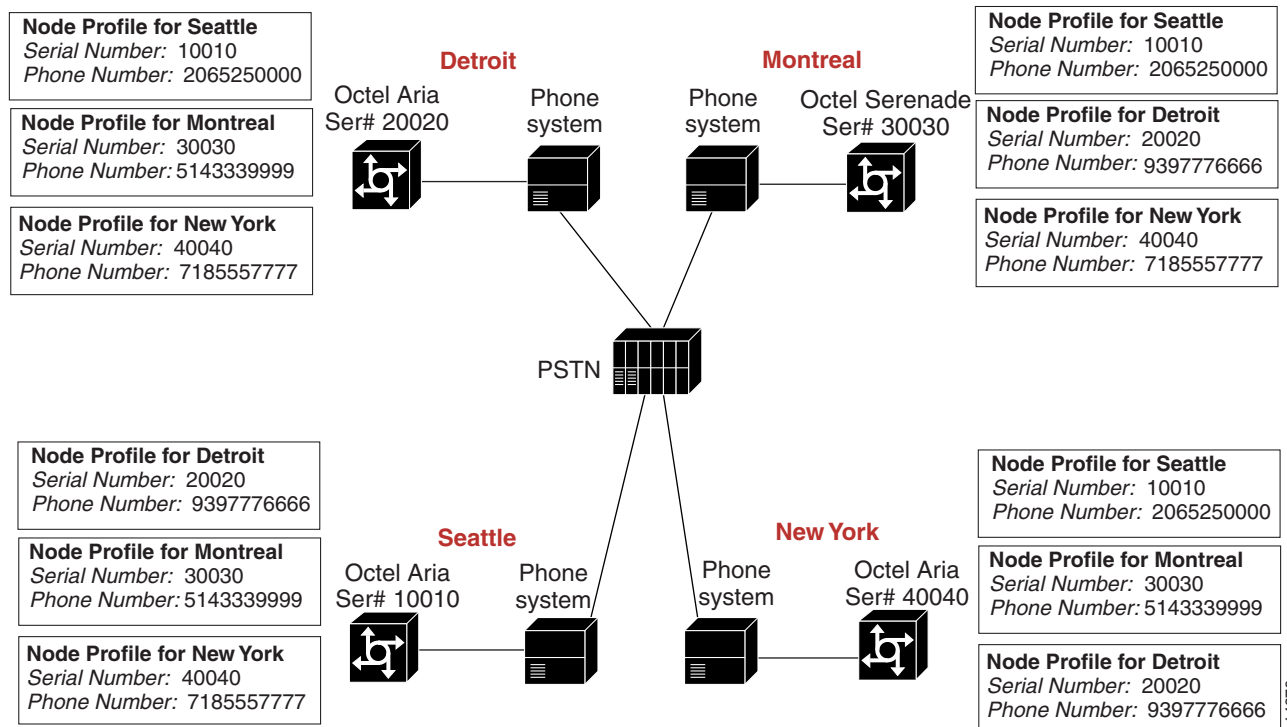

The Bridge and Cisco Unity bridgehead servers can represent one or more nodes in the network. Both the Bridge and Cisco Unity bridgehead servers must be configured with information about the other Octel nodes. The Bridge and Cisco Unity bridgehead servers must also be configured with information that identifies the nodes that they represent.

## How Nodes Are Represented on the Bridge Server

The Bridge server contains a database in which information about every node in the network is stored. On the Bridge server, you add an Octel Node object for each node with which the Bridge communicates. The Octel Node object contains the Octel server name, unique serial number, and phone number. You also define a schedule that controls when messages are sent to the node from the Bridge.

If there are multiple Bridge servers, the Octel nodes are divided among the Bridge servers, as shown in Figure 1-6.

A Cisco Unity bridgehead server combined with a Bridge server (or servers) can represent the serial number of each Octel server whose subscribers have migrated to Cisco Unity. Up to 998 nodes can be represented. On the Bridge server, you add a Unity Node object for each node that the Cisco Unity bridgehead and Bridge servers represent in the network. The Unity Node object contains the serial number and other information needed for routing messages between the Octel and Cisco Unity servers.

By using the information that you supply, the Bridge server can receive a message from an Octel node, look up the routing information from the Unity node table, reformat the message for the destination Unity node, and then send the message to the Unity node. A message coming from a Unity node and going to an Octel node goes through a similar process, but this time the Bridge server uses the Octel node table to find the routing information.

## How Octel Nodes Are Represented on the Cisco Unity Bridgehead Server

Octel nodes correspond to Bridge delivery locations in Cisco Unity. A Bridge delivery location contains a dial ID (which Cisco Unity uses as an identifier), the serial number of the corresponding Octel node, and other information that Cisco Unity needs to send messages to and receive messages from the Octel node via the Bridge. When setting up Bridge Networking, you create a delivery location to correspond to each Octel node with which Cisco Unity will communicate. You create the delivery locations by using the Cisco Unity Administrator.

In organizations with multiple Cisco Unity servers networked together, the delivery locations should be created only on the Cisco Unity bridgehead server.

### Mailbox Lengths and Prefixes

When you create a Bridge delivery location, you must specify a mailbox length. In most cases, the mailbox numbers of subscribers on an Octel server all have the same length. However, an Octel server can be configured to support different mailbox lengths. In this case, you create multiple delivery locations for the same Octel node and specify a different mailbox length on each location. For example, assume that an Octel server is configured such that some subscribers have 4-digit mailboxes and some have 5-digit mailboxes. When configuring Cisco Unity, you create two delivery locations for the same Octel node; on one location you specify a mailbox length of 4, and on the other, you specify a mailbox length of 5. Note, however, that you create only one Octel node on the Bridge server.

When Octel subscribers send messages to subscribers on other nodes in the Octel analog network, they enter a network address as the message destination. A network address consists of a node prefix, which identifies the remote server, and the mailbox number of the recipient. In many cases, the prefix is identical either to the area code where the destination node is located, or the prefix(es) defined in the phone system dialing plan. This allows subscribers to use the same number when addressing a network message that they use when calling directly. As needed to accommodate the Octel numbering plan, you can specify a prefix or prefixes for a Bridge delivery location. This allows Cisco Unity subscribers who have migrated from an Octel node to continue addressing messages to subscribers on other Octel nodes by using the same number that they used before they were migrated.

In Cisco Unity, prefixes are optional, depending on your numbering plan. Prefixes are not needed when Cisco Unity subscribers can send messages to Octel subscribers by entering the dial ID of the location followed by the recipient mailbox number. For example, assume that an Octel node has 4-digit mailboxes, and subscribers on other nodes in the Octel network enter 425xxxx when sending messages to the node. In Cisco Unity, you can create a delivery location with 425 as the dial ID and no prefix is needed.

A prefix may or may not overlap with digits in a remote mailbox number. If you specify a prefix (or prefixes) for the location, the value that you entered for the remote mailbox length is used to determine the recipient mailbox number. For example, assume that a delivery location has been defined with the following values:

Dial ID = 504  
Prefix = 256  
Remote Mailbox Length = 5

Also assume that there is an Octel subscriber with the mailbox 63452 on the Octel node that corresponds to the above delivery location, and that the Octel node has only 5-digit mailboxes.

1. A subscriber logs on to Cisco Unity and sends a message to the Octel subscriber by entering 2563452. Cisco Unity searches the directory and does not find a matching subscriber extension. Cisco Unity parses the number and finds a delivery location with the prefix 256. Because the subscriber entered a prefix, Cisco Unity uses the remote mailbox length to determine the mailbox

number from the entered number: 256**3452**. To determine the mailbox number, Cisco Unity starts at the end of the entered number, and keeps including digits until the number of digits equals the remote mailbox length. In this example, the last digit in the prefix overlaps with the first digit of the mailbox number, but the remote mailbox length allows Cisco Unity to correctly determine the mailbox number of the recipient so that the message will be delivered.

2. A subscriber logs on to Cisco Unity and sends a message to the Octel subscriber by entering 5043452. Cisco Unity searches the directory and does not find a matching subscriber extension. Cisco Unity parses the number and finds a delivery location with a dial ID of 504. In this case the remote mailbox length is ignored because the match was on the dial ID, and not the prefix. Cisco Unity determines that the mailbox number is the remaining digits of the entered number after the dial ID, 504**3452**. Because 4-digit mailboxes are not allowed on the Octel node, the message will be returned to the sender with a non-delivery receipt.

## How Unity Nodes Are Represented in Cisco Unity

The serial numbers of the nodes in the Octel analog network that the Cisco Unity bridgehead and Bridge servers represent are configured for Cisco Unity subscribers (and not for locations). Each Cisco Unity subscriber is configured with the serial number that represents a node in the Octel network together with the legacy mailbox ID of the subscriber, which identifies the subscriber in the Octel network. Combined, these numbers form a unique identifier for each subscriber. For each serial number that you configure for a group of Cisco Unity subscribers, you create a corresponding Unity node on the Bridge server.

For example, assume that Octel servers with the serial numbers 5555 and 8888 have been removed, and that the Cisco Unity Bridge now represents those nodes in the Octel network. On the Bridge, you would create the nodes shown in [Table 1-1](#).

**Table 1-1** Unity Nodes on the Bridge Server

Node Name	Node Serial Number
Paris	5555
London	8888

In this example, you would then configure the subscriber accounts in Cisco Unity with the serial numbers and mailbox IDs shown in [Table 1-2](#).

**Table 1-2** Cisco Unity Subscribers

Cisco Unity Subscriber Name	Node Serial Number	Mailbox ID
Jean	5555	3042
Claude	5555	3043
Francois	5555	3044
William	8888	8295
Elizabeth	8888	8296

The unique identifier created for each subscriber is thus made up of the Node Serial Number and the Mailbox ID. For example, the Cisco Unity subscriber Jean, shown in [Table 1-2](#), would have the unique identifier 55553042.

# Directory Information Sharing

Octel analog networking provides a feature called NameNet, which allows subscribers to:

- Address messages to people at other nodes by spelling the recipient names.
- Hear recorded name confirmation when addressing a message to someone on another node.

To provide these features to subscribers, each node needs access to the text and voice name of subscribers on other nodes. Each Octel node has a permanent directory of the subscribers associated with the node. Each directory entry includes the subscriber name, extension, and recorded voice name. Additionally, each Octel node has another directory, called the NameNet directory, with entries containing the names, mailbox numbers, and voice names of subscribers on other nodes.

There are two types of directory entries in the NameNet directory:

- **Permanent**—Permanent entries remain in the NameNet directory after they have been added, unless explicitly deleted.
- **Usage-Based**—Usage-based entries remain in the NameNet directory temporarily, depending on the network message traffic to the entry.

## Bridge Participation in NameNet

The Bridge participates in NameNet as follows:

- The Bridge maintains a permanent directory of Cisco Unity subscribers for each configured Unity node. In the Bridge Administrator, you can view the directory entries from the Unity Node page.
- The Bridge maintains a NameNet directory of Octel subscribers for each configured Octel node. In the Bridge Administrator, you can view the directory entries of each Octel node.
- The Bridge automatically adds usage-based directory entries to each Octel node directory.
- In the Bridge Administrator, the Name Aging field on the System Settings page allows you to specify how long usage-based directory entries are kept when they are not referenced. You can also disable name aging, so that the directory entries are permanent unless explicitly deleted.
- In the Bridge Administrator, you can add permanent directory entries to the Octel node directory.

### Usage-Based Entries in NameNet

The first time any Cisco Unity subscriber sends a message to an Octel subscriber, the Bridge may not have an entry in its Octel node directory for the recipient. In this case, the Bridge sends the message, and in addition makes an administrative call to the destination Octel node to obtain the name and the recorded voice name of the Octel subscriber. The Bridge then adds a usage-based directory entry to the Octel node directory. If name aging is enabled, each time a message is sent to a usage-based entry, the aging counter for the entry is reset. If the Octel subscriber does not receive any messages within the specified period of time (the default is 30 days), the Bridge deletes the directory entry. If at a later date a Cisco Unity subscriber sends a message to an Octel user whose directory entry has been deleted, the process starts again.

In Cisco Unity Bridge version 3.0(6), the Bridge can also be configured to accept directory information that is sent by the remote Octel node in a 'push' request. If the mailbox information sent by the remote node does not match any existing mailbox in the Bridge directory, a new usage-based entry is added to the directory. If the information pertains to an existing usage-based entry in the Bridge directory, the Bridge modifies the directory entry and resets the aging counter.

### Permanent Entries in NameNet

Permanent entries are not governed by the aging period. You can add new Octel node directory entries manually by using the Bridge Administrator or the Cisco Unity Bridge Mailbox Import tool. When a permanent directory entry is created, the Bridge node places an administrative call to the Octel node to obtain the name and recorded voice name. There are conditions under which a permanent entry will be deleted automatically, such as when the Bridge attempts message delivery to a mailbox and the Octel system indicates that the mailbox does not (or no longer) exist, or when a text name mismatch occurs (in which case the Bridge deletes the entry, makes a subsequent call to request the new name information, and then creates a new usage-based entry based on the information received).

If the Bridge is configured to accept 'push' requests, and new mailbox information that is sent by a remote Octel node in a 'push' pertains to an existing permanent entry, the text name and/or recorded voice name is updated, and the entry remains permanent.

For each Octel node, you define a schedule that controls when administrative calls to the node are made. Additionally, there are system-wide settings that allow you to control how often the Bridge attempts to retrieve spoken names that were not yet available when the text name was retrieved.

## How Octel Node Directory Entries Are Represented in Cisco Unity

In Cisco Unity, Octel node directory entries are represented as Bridge subscribers. A Bridge subscriber is a representation in Cisco Unity of a subscriber on an Octel node. Bridge subscribers are created in Cisco Unity to enable regular Cisco Unity subscribers to find them in the directory and send messages to them as they would to any other subscriber. Each Bridge subscriber is associated with a delivery location and has a Domino Person document. Mailbox greetings and voice names can be individually recorded for each Bridge subscriber. Messages sent to a Bridge subscriber are sent through the Bridge server to the applicable mailbox on the Octel system. Bridge subscribers do not have messages stored locally; their messages are stored on the Octel messaging system.

After a directory entry (either usage-based or permanent) is added to an Octel node directory, the Bridge sends an Add User request to Cisco Unity to create a Bridge subscriber account. The Bridge sends a text name, mailbox number, and recorded voice name for Cisco Unity to use when it creates the Bridge subscriber. If configured to do so, Cisco Unity automatically creates a Bridge subscriber and a corresponding Person Document with the information provided by the Bridge. When the Bridge deletes a directory entry, it sends a Delete User request to Cisco Unity, and if configured to do so, Cisco Unity automatically deletes both the Bridge subscriber account and the Domino Person document.

You can also manually create Bridge subscribers in Cisco Unity by using the Cisco Unity Administrator or the Cisco Unity Bulk Import wizard.

The Cisco Unity Administrator provides settings that allow you to control whether Cisco Unity should automatically create, modify, and delete Bridge subscribers. Additionally, there are settings based on delivery location that you can specify to control how extensions and names are generated for auto-created Bridge subscribers.

## UOmni Account

Directory messages from the Bridge to create, modify, or delete Bridge subscribers are routed by the Interop Gateway to a special Domino mail file called UOmni\_<Servername>. The Bridge Connector (a Cisco Unity component that runs as a Windows 2000 service called CsBridgeConnector) monitors the UOmni mail file. When the CsBridgeConnector detects a message, it parses the data in the message and sends a request to the Cisco Unity database component to make the necessary change (create, modify, or delete) to the Bridge subscriber account.

In organizations with multiple Cisco Unity servers networked together, the UOmni account needs to be created only on the Cisco Unity bridgehead server. The mail file for the UOmni account is located on the Domino server that was selected in the Message Store Configuration wizard during Cisco Unity setup.

The UOmni mail file can be moved and deleted just like any other Domino mail file, by using the Domino Administrator. Be sure to let everyone who administers Domino know about the UOmni account so that it is not moved or deleted by mistake.

For information on moving the UOmni mail file to another Domino server, see the “UOmni Mail File” section in the “Cisco Unity Data and Log Files” chapter in the *Cisco Unity Maintenance Guide*, available at [http://www.cisco.com/en/US/products/sw/voicesw/ps2237/prod\\_maintenance\\_guides\\_list.html](http://www.cisco.com/en/US/products/sw/voicesw/ps2237/prod_maintenance_guides_list.html).

## Directory Synchronization of the Cisco Unity and Bridge Directories

Cisco Unity keeps its subscriber directory synchronized with the subscriber directory on the Bridge. The CsBridgeConnector, running as a Windows 2000 service, watches for changes to Cisco Unity subscriber data by monitoring the SQL database on the Cisco Unity bridgehead server. This database includes Cisco Unity subscriber data of all Cisco Unity servers in the directory. If a change is detected, the CsBridgeConnector sends the updated data to the Bridge. The CsBridgeConnector also monitors the UOmni mailbox for changes from the Bridge so that the necessary changes to the Bridge subscriber accounts are made.

Cisco Unity does not send information about Internet, AMIS, Bridge, or VPIM subscribers to the Bridge; only information about “regular” Cisco Unity subscribers is sent to the Bridge. In the other direction, the Bridge sends information to Cisco Unity about Bridge subscribers.

Directory synchronization does not affect messaging. Subscribers can still send and receive messages when the directories are not synchronized. If Cisco Unity subscriber information is missing from the Bridge directory, the Octel system cannot retrieve the voice name when an Octel subscriber addresses a message to that Cisco Unity subscriber, but the message is still delivered.

When Cisco Unity and the Bridge are initially configured, all Cisco Unity subscriber data is sent to the Bridge automatically if the configuration was done in the exact sequence specified in the “[Task List: Setting Up Cisco Unity and the Bridge for Networking](#)” section on page 2-2. If necessary, you can force a full synchronization after the initial configuration. Subsequently, if there is a change to Cisco Unity subscriber data, only the changed data is sent to the Bridge.

For directory data about newly-created subscribers to be automatically sent to the Bridge, you first create the subscribers in Cisco Unity with Unity node serial numbers and legacy mailbox IDs defined, and then create corresponding Unity Node(s) on the Bridge. If you do the reverse and create a Unity Node on the Bridge before creating any subscribers with the same serial number, you will have to force a synchronization to send directory data to the Bridge, or delete and then add back the Unity Node on the Bridge. Subsequently, if you add more subscribers with the same serial number, Cisco Unity automatically sends the directory information to the Bridge.

## Failover and Directory Synchronization

When a Cisco Unity server is configured for failover, the Cisco Unity subscriber directory is not synchronized with the Bridge directory while the secondary server is active. When the primary server becomes active again, synchronization resumes automatically. Failover provides for replication of subscriber data between the primary and secondary Cisco Unity servers, so existing directory information will be available to subscribers no matter which server is active.

When the secondary server is active, subscribers on Cisco Unity and on the Octel system can still send and receive messages, but changes to Cisco Unity subscriber accounts will not be replicated to the Bridge immediately. For example, if you add subscriber accounts on the active secondary server, this information is not replicated to the Bridge until the primary server becomes active again.

## Time Required for a Full Synchronization

The amount of time necessary for a full synchronization depends on many factors, such as the network connection to the Bridge, the size of the directory, whether subscribers have recorded voice names, and the codec used to record the voice names. (Voice name data is large in comparison with the other subscriber information that is sent to the Bridge.) When the number of Cisco Unity subscribers in the network is 1,000 or fewer, the time required for a full directory synchronization is usually a matter of minutes. When the number of Cisco Unity subscribers in the network is 5,000 to 10,000 or above, and all have recorded voice names, the time required is usually a matter of hours.

# Maintaining the Logical Octel Network Topology Within the Cisco Unity Directory

In Octel analog networking, the serial number assigned to each Octel node is used to identify the node in the network. Just as Cisco Unity has a delivery location for each Octel node in the network, and the Bridge has an Octel Node page for each Octel node in the network, each Octel node is configured with a node profile for all the other Octel nodes in the network. Each node profile contains the serial number of the corresponding Octel node.

The serial numbers of the sending and receiving Octel nodes are exchanged via DTMF tones at the beginning of a communication session. The receiving Octel node uses the serial number it receives to verify the network-node profile of the sending node. Before the sending node transmits a voice message, it sends the mailbox number of the recipient. The receiving Octel node verifies that there is a subscriber with that mailbox number before accepting the message.

In an Octel analog network, the combination of the node serial number and the subscriber mailbox number uniquely identifies the subscriber within the network.

## Retaining the Octel Network Identity

When migrating subscribers from Octel to Cisco Unity in stages, it is important that messages sent from Cisco Unity subscribers who are migrated Octel subscribers appear to come from their former Octel server, so that reconfiguration of the network nodes on the existing Octel servers is minimized. To this end, each Cisco Unity subscriber account must be configured with a serial number and a legacy mailbox number. This also allows the remaining Octel subscribers to address messages by using the same number that they used before the subscriber migrated to Cisco Unity.

When a Cisco Unity subscriber sends a message to an Octel subscriber, the legacy serial number and mailbox number are included in the message header. When the Bridge transmits the message to the Octel node, it transmits the serial number in the message header to identify the sending node, and transmits the mailbox number to identify the sending subscriber. The receiving Octel node recognizes the serial number and accepts the message.

## Independent Numbering Plans

All Cisco Unity subscribers must be assigned a serial number and legacy mailbox number in order to send messages to and receive messages from Octel subscribers. If you will be creating Cisco Unity subscriber accounts for users who previously existed on an Octel system, use the serial number of the Octel server that the subscriber migrated from and the mailbox number that the subscriber had on the Octel system. If you will be creating Cisco Unity subscriber accounts for new users who were never subscribers on an Octel system, choose a serial number and a mailbox number that are not already in use.

The serial numbers and legacy mailbox numbers are stored in the Domino directory along with a subset of other subscriber data. For each serial number, the legacy mailbox number must be unique within the Domino directory. Depending on your Cisco Unity numbering plan, the legacy mailbox number may or may not be the same as the primary extension for the Cisco Unity subscriber.

The serial numbers and legacy mailbox numbers allow you to maintain a logical Octel analog networking topology within the Cisco Unity directory. With this scheme, Cisco Unity subscribers can maintain their previous Octel node serial number and mailbox number identities for messaging with Octel subscribers, while still allowing you to use whatever numbering plan best suits the new Cisco Unity topology.

## Collapsing Multiple Octel Nodes

When migrating to Cisco Unity in stages, you typically will migrate all the Octel subscribers from a particular node to Cisco Unity and then decommission the Octel node. The Cisco Unity bridgehead and Bridge servers represent the serial number of the Octel node whose subscribers migrated to Cisco Unity. The Cisco Unity bridgehead and Bridge servers can emulate multiple nodes in the Octel analog network.

In installations with multiple Cisco Unity servers, it does not matter whether the Cisco Unity subscribers who have migrated from one Octel server are grouped together as subscribers on one Cisco Unity server, or if they are distributed among multiple Cisco Unity servers. Because the Cisco Unity subscribers are configured with the legacy serial and mailbox numbers, their identities are the same as before the migration to the remaining Octel servers.

## Interop Gateway and Bridge Networking

The Interop Gateway for Domino is a Cisco Unity service (called CsDomInteropGty) that enables messaging between Cisco Unity and other voice messaging systems. The Interop Gateway files are copied to the Cisco Unity server during setup; however, the Interop Gateway is not installed as a service until you run the Interop Gateway Configuration wizard when configuring Cisco Unity for Bridge Networking. The Interop Gateway Configuration wizard configures and starts the service. In the Interop Gateway Configuration wizard, you specify a Domino Foreign domain name (for example, “voicemail.domain.com”) and mail file that Bridge messages will be routed through.

When subscribers use the phone to address a message to a Bridge recipient, Cisco Unity constructs a “to” address in the form OMNI:<Location Dial ID>\_<Remote Mailbox>@<ForeignDomain> for the message. Domino routes the message to the mail file that you specified in the Interop Gateway Configuration wizard. The Interop Gateway monitors this mail file. For an outbound message to a Bridge recipient, the Interop Gateway constructs a MIME message, and hands the message back to Domino for delivery to the Bridge via SMTP.

Messages from the Bridge that are received by the Domino server with the SMTP Listener service are routed to the Interop Gateway mail file for processing, after which the Interop Gateway sends the message back to Domino, which routes it to the subscriber mail file.

## Choosing the Interop Gateway Foreign Domain Name

The Foreign domain name to be used by the Interop Gateway can be whatever you would like it to be. As a best practice, however, we recommend that you use a name that follows the format <Name>.<DomainName>, where <Name> is a descriptive term and <DomainName> is the domain name of your organization, for example, UnityBridge.mydomain.com. By following this convention, you will be able to add a mail exchange (MX) record in DNS using the Interop Gateway foreign domain name and the IP address of the Domino server that handles incoming SMTP messages.

The Foreign domain name must be unique, meaning there can be no other Domain documents in Domino that have a domain name that matches what you choose for the Interop Gateway Foreign domain name. Additionally, the Foreign domain must not be used by any other program, such as a fax server. (Typically, fax servers use Foreign domains for processing and routing faxes.)

See the [“Configuring the Interop Gateway” section on page 2-7](#) for information on running the Interop Gateway Configuration wizard.

## Message Addressing Options

Cisco Unity provides the following message addressing options for addressing messages to Octel subscribers:

- Blind addressing
- Entering the extension of a Bridge subscriber
- Spelling the name of a Bridge subscriber

## Messaging Similarities and Limitations

For the most part, messaging between Cisco Unity and Octel subscribers is the same as messaging between Cisco Unity subscribers. For example:

- Messages marked urgent when they are sent are marked urgent when they are retrieved by the recipient.
- Messages marked private when they are sent are marked private when they are retrieved by the recipient.
- The future delivery of messages to Octel recipients is supported.
- Cisco Unity subscribers can send messages to Cisco Unity distribution lists that include Bridge subscribers.
- A message from a Cisco Unity subscriber addressed to multiple Octel recipients who are on the same Octel server is transmitted once to the Bridge. If all of the recipients are on the same Octel node, the Bridge makes only one phone call to the node and transmits only one message, which then is delivered to each recipient. If the recipients are on multiple Octel nodes, the Bridge makes only one phone call to each node and transmits only one message, which then is delivered to each recipient on that node.
- Fax messages can be sent, depending on Octel support.

Note the following exceptions:

- Requests for both read receipt and delivery receipt messages are returned simply as “delivery receipts.” The receipt is delivered to the sender when the message is sent from the Bridge to the Octel node, not when the Octel system places the message in the subscriber mailbox or when the message is actually read.
- E-mail messages cannot be delivered to Octel recipients even though subscribers can address and send messages to them. Instead of being delivered, e-mail messages that are sent to Octel recipients are returned to the sender as non-delivery receipts (NDRs).
- When subscribers send voice messages that are marked as low importance, the messages are treated the same as regular messages.
- If the remote Octel system is configured to send the recorded voice name in messages, Cisco Unity will play it as part of the message. When a Cisco Unity subscriber listens to a message from someone on an Octel node, if there is a matching Bridge subscriber with a recorded voice name, and if the subscriber conversation settings are configured to play the sender’s information, the voice name of the sender will be played twice.

Cisco Unity subscribers who have used the Octel phone menus will notice differences when they hear the standard Cisco Unity conversation. As an alternative to the standard Cisco Unity conversation, you can activate Cisco Unity Optional Conversation 1 so that subscribers hear message-retrieval menus that may more closely resemble the choices that they are familiar with. Note however that other menus—those that unidentified callers and Cisco Unity subscribers use to send and manage messages, as well as the menus that subscribers use to change their Cisco Unity settings—are the same as those in the Cisco Unity standard conversation.

## Blind Addressing and Bridge Networking

Blind addressing is one of the methods that Cisco Unity provides for addressing messages to Octel users. Blind addressing allows Cisco Unity to address messages to a subscriber on an Octel node when there is no corresponding Bridge subscriber in the directory.

To address a message to someone on another node, subscribers enter a blind address, which could be either of the following:

- A Bridge delivery location dial ID and the remote mailbox number of the recipient.
- A prefix defined on a Bridge delivery location and a remote mailbox number. Note that a prefix can overlap with digits in the remote mailbox number. See the [“Mailbox Lengths and Prefixes” section on page 1-7](#) for additional information.

When a subscriber addresses a message by entering a number, Cisco Unity performs a complex search. During the blind addressing phase of the search, Cisco Unity parses the number that the subscriber entered and searches for a matching delivery location prefix or dial ID. If a matching delivery location is found, Cisco Unity addresses the message without verifying that the remote mailbox number exists. Cisco Unity does provide voice name confirmation that the delivery location exists before addressing the message (assuming a voice name was recorded for the delivery location). If Cisco Unity does not find a matching location, it reports the error to the sender and does not address the message.

Because the Bridge supports NameNet, blind addressing is really only “blind”—meaning there is no corresponding Bridge subscriber in the directory and thus, no voice name confirmation—the first time a Cisco Unity subscriber sends a message to an Octel subscriber. Subsequently, if configured to do so, Cisco Unity creates a Bridge subscriber by using the text name, mailbox number, and voice name of the recipient that the Bridge retrieved from the Octel node.

For administrators of Cisco Unity, blind addressing is the option that requires the least amount of work to set up. However, the first time a message is sent to an Octel user, or when the aging period for the usage-based directory entry expires (if name aging is enabled), subscribers encounter the limitations of blind addressing:

- Subscribers can address a message only by using number mode.
- Cisco Unity cannot verify that the number entered is correct, so subscribers may inadvertently address a message to the wrong person or to a non-existent mailbox.

In Cisco Unity 4.0(5) and later, subscribers can use the Cisco Unity conversation to add and delete blind addresses in their private distribution lists. In contrast, subscribers cannot use the Cisco Unity Assistant to add blind addresses to their private lists, though they can use it to view list members and to delete any blind addresses that were added by phone. The Cisco Unity Administrator also does not allow you to add blind addresses to private lists, but you can use it to view and delete list members.

Note that when you delete a delivery location, blind addressees at that location are also removed from all private lists. Consider notifying subscribers of these potential changes to their private lists.

## Bridge Subscribers

Bridge subscribers are a representation in Cisco Unity of subscribers on the Octel system. Bridge subscribers have corresponding Domino Person documents that have “Other Internet Mail” set in the Mail System field, and they are listed in the Notes address book. When you delete Bridge subscribers, the associated Person documents are deleted automatically. Cisco Unity subscribers address messages to Bridge subscribers just as they address messages to regular subscribers, but the messages are sent via the Bridge to the appropriate mailbox on an Octel system. Bridge subscribers can be included in Cisco Unity distribution lists, and outside callers can leave messages for them (if they are listed in the Cisco Unity phone directory).

Bridge subscribers do not require additional Domino client access licenses (CALs), and they do not consume Cisco Unity subscriber licenses. The Cisco Unity subscriber license count does not change when you create Bridge subscribers.

Other than receiving messages, Bridge subscribers do not have access to other Cisco Unity features, and some sections of the Cisco Unity Administrator are disabled for Bridge subscribers. Bridge subscribers:

- Cannot log on to Cisco Unity by phone to check or send messages.
- Cannot log on to Cisco Unity by phone—or use the Cisco Unity Assistant—to adjust personal settings.
- Cannot own private lists.
- Cannot set up or receive message notifications.
- Cannot receive message waiting indications.

See the following sections for detailed information:

- [How Bridge Subscribers Are Created, page 1-17](#)
- [Creating Bridge Subscribers in Cisco Unity, page 1-17](#)
- [Creating Permanent Directory Entries on the Bridge Server, page 1-18](#)
- [Creating Bridge Subscribers and Then Creating Corresponding Permanent Directory Entries, page 1-18](#)
- [Extension Addresses, page 1-19](#)
- [Subscriber Experience with Bridge Subscribers, page 1-19](#)

- [Identified Subscriber Messaging \(Cisco Unity 4.0\(4\) or Later\)](#), page 1-19
- [Live Reply to Bridge Subscribers \(Cisco Unity 4.0\(4\) and Later\)](#), page 1-20
- [Deleting Bridge Subscribers](#), page 1-21
- [Disabling the Automatic Creation, Modification, and Deletion of Bridge Subscribers](#), page 1-21
- [Controlling How Text Names Are Parsed for Auto-Created Bridge Subscribers](#), page 1-22
- [Determining How Bridge Subscribers Appear in the Notes Address Book](#), page 1-22
- [Controlling the Extensions Assigned to Auto-Created Bridge Subscribers](#), page 1-23
- [Preventing Subscribers From Adding Individual Subscribers to Private Lists in the Cisco Unity Assistant](#), page 1-23

## How Bridge Subscribers Are Created

Before Bridge subscribers can be created, you first must create a Bridge delivery location that corresponds to each Octel node with which Cisco Unity communicates.

Bridge subscribers are automatically created when the Bridge creates usage-based directory entries for the Octel users. You can also create Bridge subscribers manually in Cisco Unity, or create permanent directory entries on the Bridge server, which results in the automatic creation of Bridge subscribers.

Note that information for creating, updating, and deleting Bridge subscribers is pushed from the Bridge server to Cisco Unity, never the reverse.

If you decide that you want to control the creation of Bridge subscriber accounts, use one of the following approaches:

- Create Bridge subscribers in Cisco Unity by using the Cisco Unity Administrator or the Cisco Unity Bulk Import wizard.
- Create permanent directory entries on the Bridge server by using the Bridge Administrator or the Cisco Unity Bridge Mailbox Import tool.
- First create the Bridge subscribers in Cisco Unity, and then create corresponding permanent directory entries on the Bridge.

## Creating Bridge Subscribers in Cisco Unity

If you want the extensions that you assign to Bridge subscribers to fit in with your numbering plan, you may need to manually create Bridge subscribers in Cisco Unity. The extension is the number that Cisco Unity subscribers enter when addressing messages to Bridge subscribers.

When creating Bridge subscribers, you specify the remote mailbox number of the user on the Octel node. The remote mailbox number may or may not be the same as the extension. You also select a Bridge delivery location with which to associate the subscriber. In organizations with multiple Cisco Unity servers, Bridge subscribers can be associated only with Bridge delivery locations that were created on the same Cisco Unity bridgehead server.

Note the following about Bridge subscribers that you manually create:

- A corresponding Octel node usage-based directory entry on the Bridge is created only when a Cisco Unity subscriber first sends a message to the Bridge subscriber. At that time, the Bridge obtains the text and recorded voice name from the Octel node, and sends this information to

Cisco Unity. If configured to do so, Cisco Unity updates the Bridge subscriber account with the text and recorded voice name from the Bridge. If you have already recorded a voice name for the Bridge subscriber, it is replaced by the voice name sent by the Bridge.

- These subscribers are subject to name aging deletion. If name aging is enabled, the name aging period starts when a corresponding Octel node directory entry is created on the Bridge.
- A corresponding Domino Person document that has “Other Internet Mail” set in the Mail System field is created at the same time the Bridge subscriber account is created.

## Creating Permanent Directory Entries on the Bridge Server

If you want the Bridge subscribers to always have recorded voice names and not be subject to name aging deletion, you should create permanent directory entries on the Bridge server. When you create a permanent Octel node directory entry, the Bridge places an administrative call to the Octel node to obtain the name and recorded voice name. The directory entry is updated with this data. The Bridge sends the data along with a request to Cisco Unity to create a corresponding Bridge subscriber account (also referred to as auto-created Bridge subscribers).

Note the following:

- The {Bridge Subscriber} Template is the default template used for auto-created Bridge subscribers. You specify the template to be used for auto-created Bridge subscribers in the Cisco Unity Administrator.
- By default, the extension assigned to an auto-created Bridge subscriber is the delivery location dial ID with the remote mailbox number added to the end (for example, if the delivery location dial ID is 111, and the remote mailbox number is 2222, the extension assigned will be 1112222).
- The auto-created Bridge subscriber that corresponds to a permanent directory entry is not subject to name-aging deletion.
- When the Bridge subscriber account is created, a corresponding Domino Person document that has “Other Internet Mail” set in the Mail System field is also created automatically.

## Creating Bridge Subscribers and Then Creating Corresponding Permanent Directory Entries

If you need the flexibility to specify extensions when Bridge subscribers are created—so that they fit with your numbering plan—and if you want the text and recorded voice names to be automatically obtained from the Octel system, you first create Bridge subscribers in Cisco Unity and then create the permanent directory entries on the Bridge server. When you create a permanent Octel node directory entry, the Bridge places an administrative call (according to the schedule defined in the Bridge Administrator for the Octel Node) to the Octel node to obtain the name and recorded voice name. The directory entry is updated with this data. The Bridge sends the data along with a request to Cisco Unity to create a corresponding Bridge subscriber account. Because you first created Bridge subscribers in Cisco Unity, a Bridge subscriber already exists that matches the Octel node and remote mailbox number of the directory entry, so the existing Bridge subscriber account is updated with the text and voice name.

## Extension Addresses

When you create a Bridge subscriber, Cisco Unity adds to the Forwarding Address field of the associated Person document an address in the following format:

OMNI:<Delivery Location Dial ID>\_<Remote Mailbox Number>@<ForeignDomain>

This special e-mail address is called an extension address or a remote address. The extension address is a combination of the delivery location Dial ID with which the Bridge subscriber is associated, the Remote Mailbox Number of the Bridge subscriber, and the Interop Gateway foreign domain name.

When subscribers use the phone to address messages to a Bridge subscriber, they dial an extension. Cisco Unity recognizes the recipient as a Bridge subscriber and retrieves the extension address from the SQL database on the Cisco Unity server.

Extension addresses are generated automatically when you create Bridge subscribers. Extension addresses are updated automatically when you change the remote mailbox number and the Dial ID of a delivery location.

## Subscriber Experience with Bridge Subscribers

Provided that Bridge subscribers have had voice names recorded for them:

- Subscribers can address messages to Bridge subscribers by using the phone, or the DUC-enabled Notes client.
- Bridge subscribers are listed in the Notes address book.
- When using the phone, subscribers can address messages to Bridge subscribers in spelled-name mode (if enabled on the system) or by extension.
- Subscribers get voice name confirmation when addressing a message to a Bridge subscriber.
- When a subscriber uses the phone to listen to a message from someone on the Octel system with a corresponding Bridge subscriber account in Cisco Unity, Cisco Unity announces who the message is from.
- Bridge subscribers can be added to Cisco Unity distribution lists.

## Identified Subscriber Messaging (Cisco Unity 4.0(4) or Later)

Identified subscriber messaging (ISM) affects what subscribers hear when they call other subscribers from their primary or alternate extensions and are forwarded to the greetings of the subscribers they call. If they then leave a message, ISM affects what the called subscriber hears and can do when listening to the message. When ISM is enabled, Cisco Unity recognizes that the calling extension is associated with a subscriber and accordingly plays the internal greeting of the called subscriber. Additionally, when the called subscriber later listens to the message, Cisco Unity plays the recorded voice name of the subscriber who left the message and allows the called subscriber to record a reply.

When a call to a Cisco Unity subscriber is forwarded to the subscriber greeting and ISM is enabled, Cisco Unity compares the calling number (ANI or caller ID) to the primary and alternate extensions of subscribers. If a match is found, Cisco Unity identifies the caller as a subscriber. When Cisco Unity compares the calling number to extensions, by default, only “regular” Cisco Unity subscribers on the local system are included in the comparison. Beginning with Cisco Unity 4.0(3), ISM can be expanded to include all Cisco Unity subscribers throughout a dialing domain.

You can enable ISM for AMIS, Bridge, and VPIM subscribers (collectively referred to as external subscribers), so that Cisco Unity will include them when comparing calling numbers to extensions. Note the following:

- After enabling ISM for external subscribers, Cisco Unity must be restarted.
- If multiple Cisco Unity servers are networked via Digital Networking, ISM functionality can be made available only on the Cisco Unity servers that are in the same dialing domain as the bridgehead server.
- You must enable ISM for external subscribers for each Cisco Unity server on which the functionality is desired.
- If a single Cisco Unity server is in use, the Cisco Unity server must be a member of a dialing domain for this functionality to be used.

Note the difference between leaving a messaging and sending a message. When a person on the remote voice messaging system with a corresponding external subscriber account records and sends a message to a Cisco Unity subscriber (as opposed to calling and leaving a message), all versions of Cisco Unity identify the message as being from the corresponding external subscriber.

The phone system provides the calling number to Cisco Unity. The number of digits included in the calling number is configurable in most phone systems. For Cisco Unity to find a matching subscriber extension, the phone system must be configured to provide the applicable number of digits in the calling number. You may also need to add alternate extensions to the subscriber accounts to match the calling number. Additionally, there may be other phone system-specific issues that prevent Cisco Unity from matching the calling number to a subscriber extension. Refer to your phone system documentation and the applicable Cisco Unity integration guide for details about the call information provided by the phone system.

See the [“Extending Identified Subscriber Messaging to Include Bridge Subscribers”](#) section on page 2-36 for details.

## Live Reply to Bridge Subscribers (Cisco Unity 4.0(4) and Later)

Live reply allows subscribers who listen to their messages by phone to respond to messages from other subscribers by calling them. When live reply is enabled, subscribers listening to messages by phone can reply to a subscriber message by pressing 4-4 to have Cisco Unity call the subscriber directly. (Subscribers using Optional Conversation 1 press 8-8 for live reply.) Note that whether subscribers have access to the live reply feature depends on their class of service settings. (Live reply is enabled on the Subscribers > Class of Service > Messages page in the Cisco Unity Administrator.)

Subscribers can live reply to messages from subscribers on other voice messaging systems who have corresponding Bridge subscriber accounts in Cisco Unity. In order for the live reply call to be successfully transferred, a call transfer number must be configured for the Bridge subscribers.

Note that a live reply to a Bridge subscriber is always done via a release to phone system transfer, even when both the Cisco Unity subscriber who is replying to a message and the Bridge subscriber have accounts on the same Cisco Unity server. On a release to switch transfer, Cisco Unity dials the call transfer number configured for the Bridge subscriber and hangs up, leaving the phone system to handle the call. Note the following limitations with release to switch transfers:

- The Bridge subscriber call screening, call holding, and announce features are ignored.
- The call transfer setting “No (Send Directly to Subscriber's Greeting)” is ignored. Cisco Unity dials the Bridge subscriber extension and hangs up. If the subscriber extension is a valid extension on the phone system that Cisco Unity is integrated with, then the subscriber phone rings. If the subscriber

extension is not a valid phone extension, what happens to the call after that depends on the phone system and how it is configured. If you do not configure the phone system to handle calls to the subscriber extensions, the caller may be disconnected.

Note the following:

- Live reply to Bridge subscribers is enabled automatically, and cannot be disabled.
- Live replies to Bridge subscribers with accounts on other Cisco Unity servers do not use the cross-server live reply functionality that can be used to live reply to Cisco Unity subscribers with accounts on other Cisco Unity servers. However, for live reply to be offered when a Cisco Unity subscriber replies to a message from a Bridge subscriber with a subscriber account on another Cisco Unity server, the servers must be in the same dialing domain.

## Deleting Bridge Subscribers

Each Bridge subscriber is associated with a Domino Person document. When Bridge subscribers are deleted, the associated Person documents are automatically deleted.

You can delete Bridge subscribers one at a time in the Cisco Unity Administrator. As a subscriber is deleted in the Cisco Unity Administrator, the associated Person document is automatically deleted as well. This is true for both auto-created Bridge subscribers and Bridge subscribers that have been manually created.

To delete all of the Bridge subscribers associated with a delivery location, the underlying Person documents associated with the subscribers, and the delivery location itself, use the Global Subscriber Manager, available in Tools Depot.

If you delete the corresponding directory entries on the Bridge server by using the Bridge Administrator or the Cisco Unity Bridge Mailbox Import tool, both the Bridge subscribers in Cisco Unity and the Domino Person documents are deleted automatically. The Person documents are also deleted when the Bridge sends a deletion request to Cisco Unity to delete a Bridge subscriber because the name aging period has expired or because there was an indication on message delivery to an Octel system that the target recipient no longer exists. Note that when a parent Octel Node profile is deleted from the Bridge, deletion requests for any remaining directory entries associated with that Octel Node will not be sent to Cisco Unity. Any remaining Bridge subscribers and Person documents associated with this Octel Node will not be deleted automatically.

## Disabling the Automatic Creation, Modification, and Deletion of Bridge Subscribers

The automatic synchronization of directory information between the Bridge and Cisco Unity is performed by the CsBridgeConnector service on the Cisco Unity bridgehead server. The CsBridgeConnector service:

- Monitors the Cisco Unity subscriber database for changes and sends updates to the Bridge so that the Bridge can update its directory of Cisco Unity subscribers. By doing so, the Bridge can respond to remote Octel node requests for Cisco Unity subscriber voice and text names.
- Handles change requests sent from the Bridge after it retrieves voice and text names of remote Octel node subscribers. The CsBridgeConnector service adds, deletes, and modifies Bridge subscribers and their associated Domino Person documents. This allows Cisco Unity subscribers to address remote Octel node subscribers by spelled name, and provides spoken name confirmation of the addressee when selected. It also allows these remote Octel subscribers to be added to private and public Cisco Unity distribution lists.

The CsBridgeConnector service should never be disabled on a Cisco Unity bridgehead server. Doing so could result in a backlog of directory messages from the Bridge, consuming large amounts of Domino storage, and preventing Cisco Unity subscriber voice and text names from being available to the remote Octel nodes upon request.

However, there may be situations where you want to disable the automatic creation, deletion, and/or modification of Bridge subscribers and Person documents by the CsBridgeConnector. For example, you may want to disable this functionality for one of the following reasons:

- You may want to have control over the text and voice names for Bridge subscribers. Disabling CsBridgeConnector auto-synchronization of these properties ensures that the changes you make to Bridge subscribers will not be overwritten by directory information propagated from remote Octel nodes via the Bridge.
- You may not want to create Bridge subscribers at all; instead, you may want Cisco Unity subscribers to use blind addressing when addressing messages to subscribers on the Octel system.

**Caution**

---

Disabling any CsBridgeConnector auto-synchronization functionality requires manual maintenance of any Bridge subscribers and their associated Person documents. Failure to keep Bridge subscriber information current can result in Cisco Unity subscribers sending voice messages to unintended recipients, or not finding remote Octel subscribers in the directory as expected.

---

You can control the creation, modification, and deletion of auto-created Bridge subscribers in the Cisco Unity Administrator.

## Controlling How Text Names Are Parsed for Auto-Created Bridge Subscribers

In Cisco Unity, the first and last names of subscribers are stored as distinct fields in the directory, which allows directory lookups to be configured by either the last or the first name. However, Octel subscriber names are stored as one single name. To comply with Octel analog networking, when the Bridge and remote Octel systems exchange directory information, only a single field is passed for the text name. The CsBridgeConnector service on the Cisco Unity bridgehead server parses the text name sent from an Octel system via the Bridge into separate first and last name fields when the accounts for auto-created Bridge subscribers are created or updated.

If the text name includes one or more comma characters, the CsBridgeConnector service parses the text name as follows:

- All characters after the first comma in the string are saved as the first name.
- All characters before the first comma in the string are saved as the last name.

For example, if “Bader, Kelly” is the text name, “Kelly” is saved as the first name and “Bader” is saved as the last name.

In some cases, the text names on the Octel systems do not include a comma. In this case, you can control how the CsBridgeConnector service parses the text name on a delivery location basis with the setting “If the Octel Text Name Has No Comma.”

## Determining How Bridge Subscribers Appear in the Notes Address Book

Depending on your installation, the users of the remote voice messaging system may already have Domino user accounts that they use for e-mail. Therefore, when Bridge subscriber accounts are created for them, the Notes address book will contain duplicate listings—the existing user account that is used

for e-mail, and a new one associated with the Bridge subscriber that is used only for voice mail. Both listings are included in the Notes address book. This means that people may inadvertently send e-mail messages to the Bridge subscribers, which should be used only for addressing voice messages.

To discourage people from inadvertently sending e-mail messages to Bridge subscribers, you can append text to either the first or last name so that subscribers can distinguish the Bridge subscriber from a user account. In this way, you can reduce the number of e-mail messages inadvertently sent to Bridge subscribers and simplify addressing for those who send voice messages to them at the same time. For example, you could append “ - Voice mail” to the first name of each Bridge subscriber, and the names would appear in the Notes address book as follows:

Abade, Alex  
Abade, Alex - Voice mail  
Bader, Kelly  
Bader, Kelly - Voice mail  
Campbell, Terry  
Campbell, Terry - Voice mail  
Cho, Li  
Cho, Li - Voice mail

In this way, subscribers can easily determine which address is appropriate to use when they send voice messages to Bridge subscribers. Additionally, when subscribers use the Notes to address a voice message to a Bridge subscriber, they can be confident that the address is formatted correctly.

## Controlling the Extensions Assigned to Auto-Created Bridge Subscribers

By default, the primary extension assigned to an auto-created Bridge subscriber consists of the delivery location dial ID followed by the remote mailbox number. If you prefer that the dial ID not be included in the extensions for auto-created Bridge subscribers, you can change the setting in the Cisco Unity Administrator.

## Preventing Subscribers From Adding Individual Subscribers to Private Lists in the Cisco Unity Assistant

In the transition from a legacy voice messaging system to Cisco Unity, your organization may choose to migrate users to Cisco Unity in phases. As a result, Cisco Unity will likely support both regular subscribers and “external” subscribers—Bridge, AMIS, or VPIM contacts (as applicable)—at the same time. Regular subscribers can send messages to external subscribers, and even add them to their private distribution lists during the transition.

However, once external subscribers are converted into regular Cisco Unity subscribers, they are automatically removed from all private lists without notifying private list owners. When this occurs, subscribers may continue to send messages to their private lists without realizing that some of their intended recipients no longer receive them.

When convenient and practical, Cisco Unity administrators should notify subscribers when external subscribers are converted to regular subscribers, notifying subscribers that they should re-add the newly migrated subscribers to existing private lists, as applicable. During the migration phase, you may also want to consider preventing subscribers from adding subscribers to their private lists in the Cisco Unity Assistant, and asking them not to use the Cisco Unity phone menus to do so—at least until the migration process is complete.

Use the following procedure to prevent all subscribers associated with the Cisco Unity server from adding individual subscribers to their private lists in the Cisco Unity Assistant. The procedure does not prevent subscribers from using the Cisco Unity phone menus to add regular and external subscribers to their private lists, nor does it prevent subscribers from addressing messages to regular and external subscribers.

#### To Prevent Subscribers From Adding Individual Subscribers to Private Lists in the Cisco Unity Assistant

- 
- Step 1** On the Cisco Unity server desktop, double-click the **Cisco Unity Tools Depot** icon.
- Step 2** In the left pane, under Administrative Tools, double-click **Advanced Settings Tool**.
- Step 3** In the Unity Settings pane, click **Unity Assistant—Do Not Allow Subscribers to Add Subscribers to Private Lists**.
- Step 4** In the New Value list, click **1**, and then click **Set** so that when subscribers add members to their lists in the Cisco Unity Assistant, the Find Names dialog box does not display the Subscribers tab. (Subscribers can continue to add distribution lists to their lists from the Distribution Lists tab.)
- Step 5** When prompted, click **OK**.
- Step 6** Click **Exit**.
- You do not need to restart Cisco Unity to enable the change.
- 

## Supported Codecs

On the Unity Node Configuration page in the Bridge Administrator, you can select which codec will be used to encode voice messages when they are sent from the Bridge to Cisco Unity subscribers: either the G.711 or the G.729a codec. The default codec is G.711.

All recorded voice names from the Bridge to the Cisco Unity bridgehead server will be sent by using the codec specified on the first Unity Node listed on the Unity Nodes page. For example, assume that the three Unity Nodes show in [Table 1-3](#) have been created, and that UnityGroup1 is listed first on the Unity Nodes page.

**Table 1-3**      **Codec Example**

Name	Serial Number	Codec
UnityGroup1	9000	G.711
UnityGroup2	90000	G.729a
UnityGroup3	9001	G.729a

In this example, all recorded voice names for all Octel node directory entries will be sent from this Bridge server to the Cisco Unity bridgehead server by using the G.711 codec.

We recommend that the same codec setting be used for all Unity Nodes configured on the Bridge server.

Voice messages that are sent from Cisco Unity to the Bridge can also be recorded with either the G.711 or the G.729a codec. The default is the G.711 codec. Although Cisco Unity supports other codecs, the Bridge supports only G.711 or G.729a.

## Notable Behavior

This section describes notable behavior of Bridge Networking. See the following sections for more information:

- [Call Transfer Settings and Bridge Subscribers](#), page 1-25
- [Directory Lookups of Asian and European Names May Fail](#), page 1-26
- [Distribution Lists](#), page 1-27
- [Inbound Search Scope](#), page 1-27
- [Some Messages to Cisco Unity Are Delayed](#), page 1-27
- [Automatic Gain Control Applied to Messages Sent from the Bridge to Cisco Unity \(Bridge 3.0\(5\) and Later\)](#), page 1-27
- [Cisco Unity Subscribers Receive Extended-Absence Notification from Octel Servers \(Cisco Unity 4.0\(4\) and Later\)](#), page 1-28

## Call Transfer Settings and Bridge Subscribers

In installations with multiple Cisco Unity servers networked via Digital Networking, the number that Cisco Unity uses for call transfers to a subscriber is the only number replicated among the Cisco Unity servers; none of the other settings on the Subscriber > Call Transfer page in the Cisco Unity Administrator are replicated. For example, in [Figure 1-8](#), call transfers are set to ring the subscriber at the number 9,5551212. The only call transfer setting that is replicated to other Cisco Unity servers is the call transfer number 9,5551212. If the setting was “Yes, ring subscriber’s extension” instead, the number 3047 would be replicated.

**Figure 1-8** Only the Call Transfer Number Is Replicated

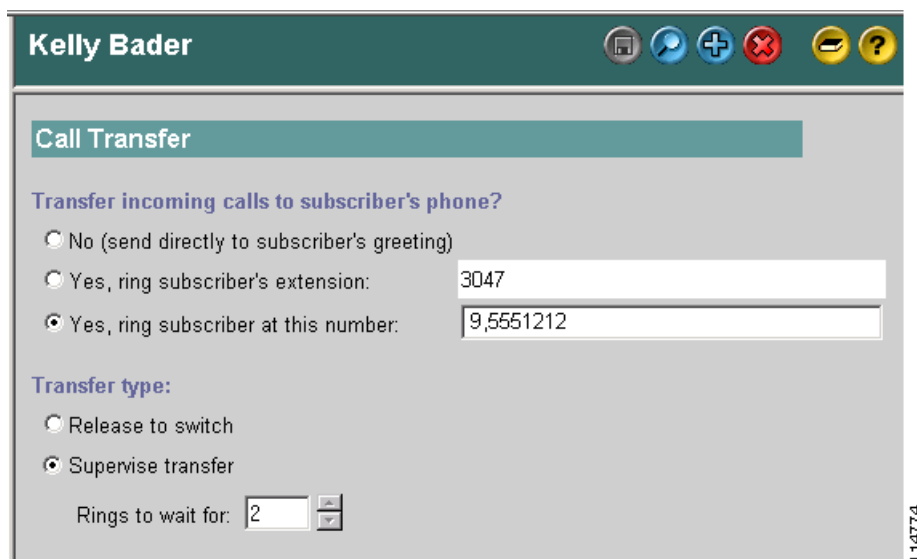

When the call transfer setting is set to “No (send directly to subscriber’s greeting),” the call transfer number is automatically set to the subscriber extension (3047 in the example above), which is replicated to the other networked Cisco Unity servers.

Call transfers to Bridge subscribers created on other Cisco Unity servers are always handled by the phone system (release to switch)—rather than by Cisco Unity (supervised transfer)—even if the subscribers are set up for supervised transfers (as in the above example). The release to switch call transfers happen when:

- A Cisco Unity subscriber chooses to call the sender (live reply) after listening to a message left by a Bridge subscriber. (Live replies to Bridge subscribers are always done release to switch, even when the reply is to a Bridge subscriber on the same Cisco Unity server.)
- A caller enters the extension of a Bridge subscriber from the automated attendant (for example from the opening greeting), and the Bridge subscriber account is on another Cisco Unity server.
- A caller spells the name of a Bridge subscriber from a directory handler, and the Bridge subscriber account is on another Cisco Unity server.

On a release to switch transfer, Cisco Unity dials the call transfer number configured for the Bridge subscriber and hangs up, leaving the phone system to handle the call. Note the following limitations with release to switch transfers:

- The Bridge subscriber call screening, call holding, and announce features are ignored.
- The call transfer setting “No (Send Directly to Subscriber's Greeting)” is ignored. Cisco Unity dials the Bridge subscriber extension and hangs up. If the subscriber extension is a valid extension on the phone system that Cisco Unity is integrated with, then the subscriber phone rings. If the subscriber extension is not a valid phone extension, what happens to the call after that depends on the phone system and how it is configured. If you do not configure the phone system to handle calls to the subscriber extensions, the caller may be disconnected.

## Directory Lookups of Asian and European Names May Fail

Octel voice messaging systems and the Bridge encode subscriber text names in 7-bit ASCII format, which can represent only 128 unique characters. Some European languages need 8 bits to represent certain characters, expanding the character range from 128 to 255. Additionally, languages such as Japanese Kanji include many more characters and require two bytes (16 bits) to represent each character.

Cisco Unity uses the industry-standard Unicode, which employs a 16-bit coding scheme that allows for 65,536 distinct characters—more than enough to represent the characters necessary to any European or Asian language.

The Bridge maintains a permanent directory of Cisco Unity subscribers, including text name, extension, and voice name. Cisco Unity keeps its subscriber directory in synch with the subscriber directory on the Bridge. However, before sending subscriber data to the Bridge, Cisco Unity converts the subscriber text names, which it stores in Unicode, to 7-bit ASCII. Because the first 128 characters in Unicode map exactly to the 128 characters in 7-bit ASCII, English-language names and most European names are converted exactly.

However, European- and Asian-language names that include characters from the extended range cannot be represented in 7-bit ASCII. Therefore, directory lookups by name on Octel systems may fail to find Cisco Unity subscribers whose names include characters that cannot be represented in 7-bit ASCII. This means that Octel subscribers cannot address messages to a Cisco Unity subscriber by spelled-name if the Cisco Unity subscriber name includes characters that cannot be represented in 7-bit ASCII. In this circumstance, Octel subscribers can still address messages by entering the subscriber extension, which finds the subscriber data in the directory, and the Octel subscribers will still get voice name confirmation.

## Distribution Lists

Cisco Unity requires that messages from the Bridge be addressed to subscribers only, and not to distribution lists. Therefore, Octel subscribers cannot address messages to Cisco Unity distribution lists.

This is true in the other direction as well—Octel analog networking does not allow subscribers to address messages to a distribution list that was created on remote Octel nodes. Therefore, Cisco Unity subscribers cannot address messages to Octel distribution lists.

However, you can mitigate this situation as follows:

- Add Bridge subscribers to private or public distribution lists on Cisco Unity.
- Add blind addresses to private lists.
- Add the remote addresses of Cisco Unity subscribers to Octel distribution lists. (Note that these addresses do not have to already exist in the NameNet directory.)

## Inbound Search Scope

In installations with multiple Cisco Unity servers networked together, the search scope for a matching subscriber for inbound messages sent from the Bridge is set to the global directory. It is not possible to limit the inbound search scope to either a dialing domain or to the local Cisco Unity server. Typically, this is not an issue because the serial number and legacy mailbox number are used for routing messages from Octel subscribers to Cisco Unity subscribers.

Although the combination of serial number and legacy mailbox number should be unique within the global directory, it is possible that you could inadvertently create or modify a subscriber account with non-unique numbers due to directory replication lag time. If two (or more) Cisco Unity subscribers have identical serial numbers and legacy mailbox numbers, messages from Octel subscribers will not be delivered by the Interop Gateway to any of the Cisco Unity subscribers with the duplicate numbers.

## Some Messages to Cisco Unity Are Delayed

Messaging between Cisco Unity and the Bridge is done by using SMTP through Domino. If the SMTP connection between the Bridge and Domino goes down, messages arriving at the Bridge from Octel subscribers cannot be delivered. The Bridge stores the messages that cannot be delivered and attempts to send them 20 minutes later. This 20-minute retry interval is not configurable.

When the SMTP connection comes back up, new messages coming from Octel subscribers are delivered immediately. However, the Bridge does not send the messages that previously could not be delivered until the end of the retry interval. Therefore, it is possible that some messages could be stored on the Bridge for up to 20 minutes before they are delivered, even though other messages are delivered immediately.

## Automatic Gain Control Applied to Messages Sent from the Bridge to Cisco Unity (Bridge 3.0(5) and Later)

The Automatic Gain Control (AGC) feature of Cisco Unity adjusts the volume of voice messages as they are recorded, compensating for variations in the level of the incoming audio signal. The AGC provides subscribers with consistent message-playback levels through the normalization of recordings, and it is enabled by default in Cisco Unity versions 3.1(2c) and later.

The AGC feature makes the volume level of messages from Octel and Cisco Unity subscribers consistent. Before the Bridge sends messages from Octel to Cisco Unity, the gain level is set to the same default level that Cisco Unity uses.

## Cisco Unity Subscribers Receive Extended-Absence Notification from Octel Servers (Cisco Unity 4.0(4) and Later)

In Cisco Unity 4.0(4) and later, Cisco Unity subscribers are notified when an Octel recipient has enabled an extended-absence greeting, and are notified whether or not the message was accepted.

An extended-absence greeting can be enabled to override all other greetings. When an Octel subscriber with an enabled extended-absence greeting receives a message from another node on the Octel analog network—including the Cisco Unity Bridge—the receiving Octel server will do one of the following (depending on the Octel subscriber class of service settings):

- Deliver the message to the Octel subscriber mailbox, and send a delivery receipt to the sender explaining that the message was delivered even though the extended-absence greeting of the recipient is enabled.
- Reject the message, and send a nondelivery receipt to the sender explaining that the message was not delivered because the Octel subscriber has an extended-absence greeting enabled.

The Bridge passes along the notification (either the delivery receipt or the nondelivery receipt) to the Interop Gateway, which sets a predetermined reason code in the receipt. The reason code in the receipt is interpreted by the Cisco Unity conversation—also known as the TUI (telephone user interface)—to provide Cisco Unity subscribers with notification of the extended absence. The reason code in the receipt is not interpreted by the DUC-enabled Notes client, so subscribers who use Notes are not provided with notification of the extended absence.

This functionality requires that you enable the Bridge server to send the delivery receipt, as described in the “[Enabling the Bridge Server to Send Extended-Absence Delivery Receipts](#)” section on page 2-38.

## Additional Bridge-Related Documentation

In addition to this guide, see the following documentation for information related to Bridge Networking:

- For information on the initial design using the Bridge and on planning a migration, see the *Cisco Unity Bridge Design Guide*, available at [http://www.cisco.com/en/US/products/sw/voicesw/ps2237/products\\_implementation\\_design\\_guides\\_list.html](http://www.cisco.com/en/US/products/sw/voicesw/ps2237/products_implementation_design_guides_list.html).
- For information on setting up the Bridge server, see the *Cisco Unity Bridge Installation Guide, Release 3.1 (With IBM Lotus Domino)*, available at [http://www.cisco.com/en/US/products/sw/voicesw/ps2237/prod\\_installation\\_guides\\_list.html](http://www.cisco.com/en/US/products/sw/voicesw/ps2237/prod_installation_guides_list.html).
- For a list of Octel voice messaging systems that the Bridge supports, and requirements for the Bridge server, see *Cisco Unity Bridge 3.1 System Requirements, and Supported Hardware and Software*, available at [http://www.cisco.com/en/US/products/sw/voicesw/ps2237/prod\\_installation\\_guides\\_list.html](http://www.cisco.com/en/US/products/sw/voicesw/ps2237/prod_installation_guides_list.html).
- For version requirements and other information, see the “Bridge Networking Requirements” section of *Cisco Unity Networking Options Requirements*, available at [http://www.cisco.com/en/US/products/sw/voicesw/ps2237/products\\_device\\_support\\_tables\\_list.html](http://www.cisco.com/en/US/products/sw/voicesw/ps2237/products_device_support_tables_list.html).

For information on changes in functionality, support, and requirements, see the following release notes:

- *Release Notes for Cisco Unity Bridge*
- *Release Notes for Cisco Unity*

All referenced release notes are available at

[http://www.cisco.com/en/US/products/sw/voicesw/ps2237/prod\\_release\\_notes\\_list.html](http://www.cisco.com/en/US/products/sw/voicesw/ps2237/prod_release_notes_list.html).

