



# Application Server 5.0 Configuration Guide



# Please Read

## Important

Please read this entire guide. If this guide provides installation or operation instructions, give particular attention to all safety statements included in this guide.

# Notices

## Trademark Acknowledgments

Cisco and the Cisco logo are trademarks or registered trademarks of Cisco and/or its affiliates in the U.S. and other countries. A listing of Cisco's trademarks can be found at [www.cisco.com/go/trademarks](http://www.cisco.com/go/trademarks).

Third party trademarks mentioned are the property of their respective owners.

The use of the word partner does not imply a partnership relationship between Cisco and any other company. (1009R)

## Publication Disclaimer

Cisco Systems, Inc. assumes no responsibility for errors or omissions that may appear in this publication. We reserve the right to change this publication at any time without notice. This document is not to be construed as conferring by implication, estoppel, or otherwise any license or right under any copyright or patent, whether or not the use of any information in this document employs an invention claimed in any existing or later issued patent.

## Copyright

© 2012 Cisco and/or its affiliates. All rights reserved. Printed in the United States of America.

Information in this publication is subject to change without notice. No part of this publication may be reproduced or transmitted in any form, by photocopy, microfilm, xerography, or any other means, or incorporated into any information retrieval system, electronic or mechanical, for any purpose, without the express permission of Cisco Systems, Inc.

# Contents

<b>About This Guide</b>	<b>v</b>
<b>Chapter 1 Introducing the Application Server</b>	<b>1</b>
Understand the DBDS Network .....	2
View DNCS Monitor Windows .....	5
Online Help.....	9
<b>Chapter 2 Getting Started</b>	<b>13</b>
Power On the Application Server Workstation.....	14
Start Application Server Processes .....	15
<b>Chapter 3 Setting Up Language Support</b>	<b>19</b>
Set Up Supported Languages.....	20
Configure Screen Language .....	21
One-For-All.....	24
<b>Chapter 4 Setting Up Described Video Services</b>	<b>27</b>
Enable DVS Support.....	29
Configure DVS Support.....	33
<b>Chapter 5 Defining PPV Services and Events</b>	<b>37</b>
Define PPV Services.....	38
Understand Windows and Barkers.....	45
Define PPV Events.....	50
<b>Chapter 6 Setting Up the Interactive Program Guide</b>	<b>59</b>
Before You Begin.....	61
Set Up the IPG .....	64
Add IPG Data Manually .....	74
Edit Existing IPG Data .....	77
Add Your Company's Logo to the Main IPG Screen.....	79
Configurations That Enhance Your Subscribers' Experience .....	83
IPG Memory Usage Settings .....	84
Adjust How DHCTs Use IPG Memory.....	90
Selecting the Number of Days of IPG Data to Produce.....	95

Graying Out Unauthorized Channels in IPG .....	96
Configure the ISDP for EPG Search .....	97
<b>Chapter 7 Setting Up a Virtual Channel Service</b>	<b>103</b>
Configure the VCS Broadcast File System (BFS) .....	104
Build a Virtual Channel Source File .....	108
Set Up a Virtual Channel Service.....	111
<b>Chapter 8 Enabling Power On Features</b>	<b>115</b>
Set Up Power On Keys.....	116
Configure Power On Keys.....	117
Configure Power On Channel Options.....	121
<b>Chapter 9 Enabling the Enhance Purchase PIN Feature</b>	<b>127</b>
Configure Purchase PIN .....	128
<b>Chapter 10 Enabling Tracing on the Application Server</b>	<b>129</b>
Enabling Logging.....	130
View the Log Files.....	131
<b>Chapter 11 Customer Information</b>	<b>133</b>

# About This Guide

## Introduction

The Application Server works with the Digital Network Control System (DNCS) to deliver digital applications to subscribers. Together, the Application Server and the DNCS form the core of the Digital Broadband Delivery System (DBDS). The DBDS delivers broadcast data and digital applications from the headend to the subscribers' homes.

This guide provides procedures for setting up and managing digital applications such as pay-per-view (PPV) and the Interactive Program Guide (IPG) on the Application Server.

This guide contains procedures for defining digital applications as well as deleting and changing the definitions for these applications. You will not complete these procedures in the order they are presented here. In addition, you will not necessarily use all of the procedures in this guide, depending on the applications that you offer to your subscribers.

**Note:** The illustrations and screen captures shown in this guide may not exactly match what displays on your system.

## Purpose

The purpose of this guide is to enable users to manage the applications that reside on Application Server 5.0. You will learn how to set up, or provision, each of the applications that reside on the Application Server.

## Prerequisites

Application Server 5.0 (AS 5.0) requires System Release (SR) 4.4 and later.

## Audience

This guide is intended for system operators who are using Application Server 5.0 with the system release listed earlier.

## Document Version

This is the first formal release of this document.



# 1

---

## Introducing the Application Server

This chapter explains the purpose of the Application Server, how it differs from the Digital Network Control System (DNCS), and how it fits into the Digital Broadband Delivery System (DBDS). In addition, this chapter provides an overview of how to monitor the status of the Application Server and how to use the Online Help system.

### In This Chapter

- Understand the DBDS Network ..... 2
- View DNCS Monitor Windows ..... 5
- Online Help ..... 9

## Understand the DBDS Network

The Application Server is a workstation that transfers data to the DNCS. This may be a stand-alone workstation, or it may be a logical workstation that is integrated with the DNCS hardware.

The Application Server runs the applications that are necessary for providing digital services to subscribers. This User Guide explains how to set up, or provision, the applications so that the DBDS can deliver digital services to subscribers.

**Important:** The features described in some chapters of this User Guide depend on the IPG/EPG navigator that runs on your set-tops. Contact your application provider if you have any questions about feature availability in your implementation.

**Important Note for Multiple-Site (RCS-Enabled) Systems:** When provisioning an application for the Broadcast File System (BFS), manually set up any BFS server or source for the “AllSites” site only, and not for any other individual sites in your system. Otherwise, the server and source will fail. Currently, VCS and DVD are the only applications the Application Server uses that must be set up in this manner. Chapter 7 and Chapter 9 provide more information on setting up applications for RCS-enabled systems.

The DNCS graphical user interface (GUI) allows you to manage and monitor the Application Server. The following two windows are available on the DNCS desktop and provide the means of entry to the Application Server as needed:

- DNCS Administrative Console Status
- DNCS Administrative Console

*View DNCS Monitor Windows* (on page 5) describes these windows and explains how they relate to the Application Server.

## The DBDS

This section briefly describes the relationship between the Application Server and the DBDS and explains how the Application Server works with the DBDS.

The DBDS is a network of hardware and software elements, including the Application Server, that connects content servers to DHCTs in order to deliver MPEG-2 video, audio, digital data, and analog services to subscribers. The following diagrams illustrate how the various hardware elements interconnect to form a DBDS.

The following illustration shows a basic DBDS with a stand-alone Application Server and no optional features.

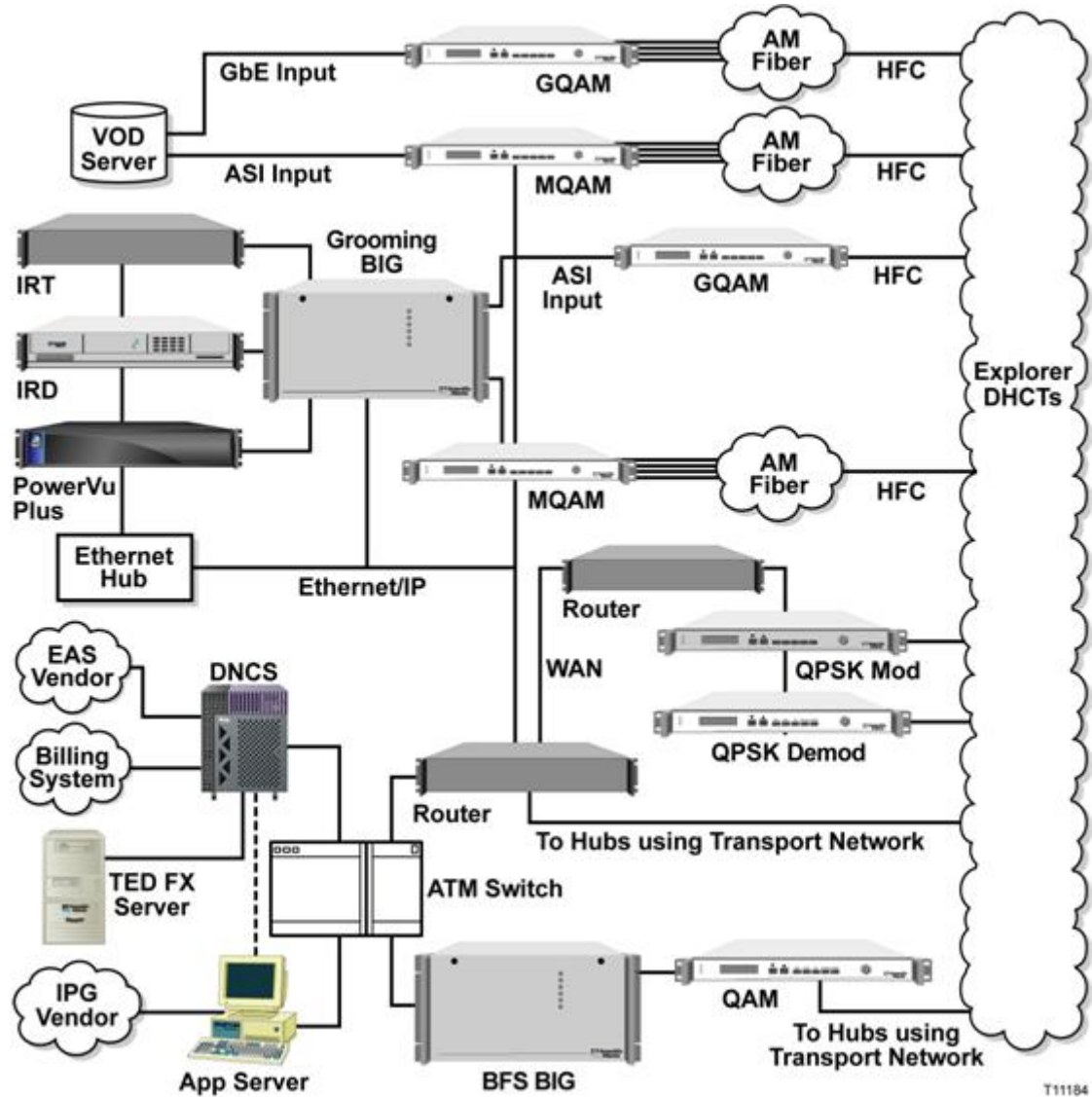

The following illustration shows a basic DBDS with an integrated Application Server and no optional features.

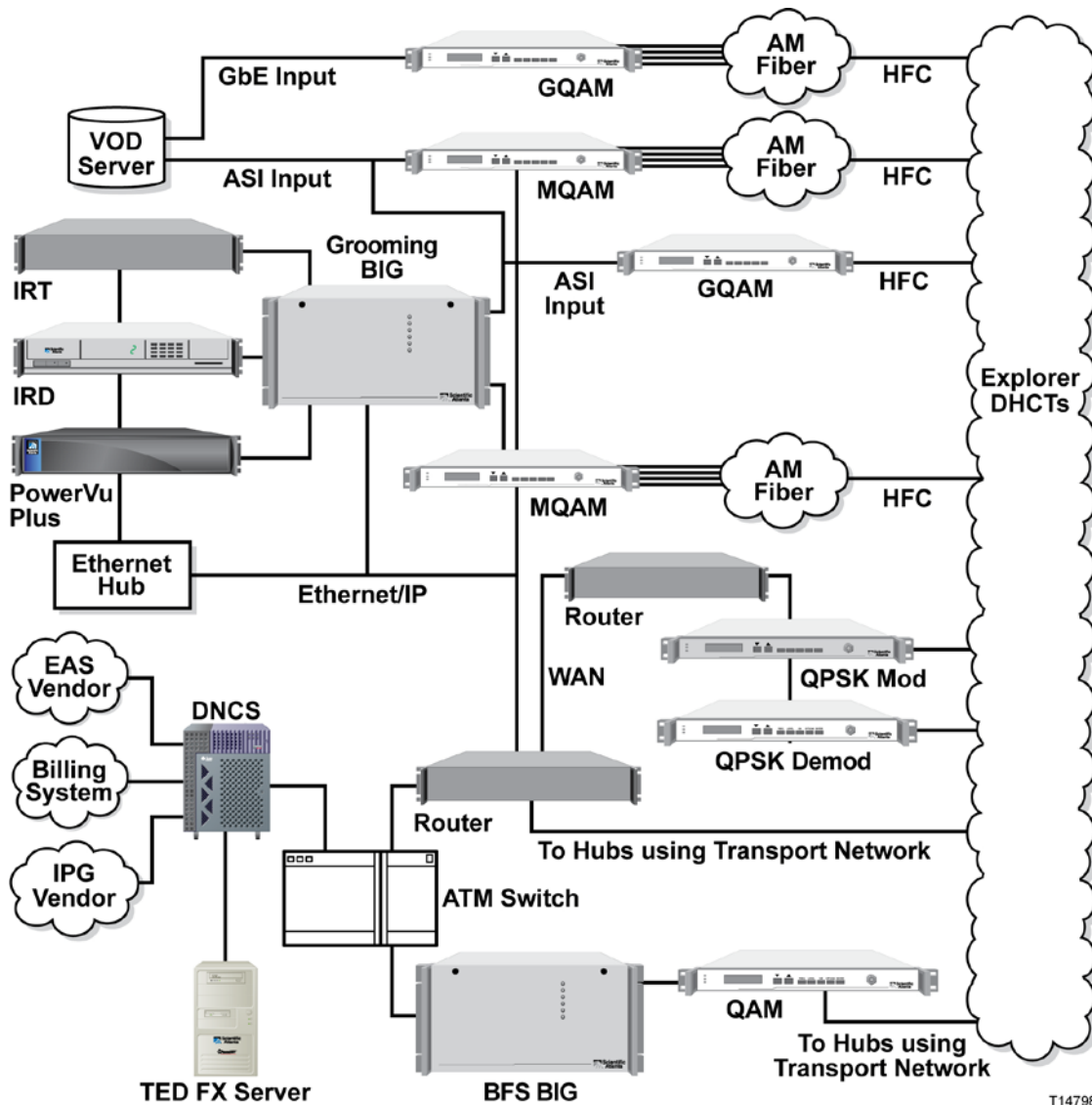

T14798

## View DNCS Monitor Windows

### DNCS Administrative Console Status Window

Use the DNCS Administrative Console Status window to determine the overall status of various processes and network elements. To determine the status of the individual Application Server processes, see AppServer Control Window, next in this section.

The DNCS Administrative Console Status window is divided into the following four areas:

- DNCS
- Spectrum NMS (if used)
- AppServer
- Alarms

**Note:** Instead of Spectrum Network Management System (NMS), we offer a separate product called the DBDS Alarm Management System to help you monitor your network elements. For more information, contact your customer service representative.

The following illustration indicates that the DNCS; Application Server (AppServer); and Spectrum NMS, if used, are all running.

In this case, NMS is not running, which is indicated by the red color of the associated box (instead of green) and the display value of Inactive (instead of Running).

The Alarms area indicates the number of critical (Cr), major (Mj), and minor (Mn) alarm conditions, if any, that are present in the DBDS.

## AppServer Control Window

If you click the Control button in the AppServer area of the DNCS Administrative Console Status window, the AppServer Control window appears. The AppServer Control window provides a list of all the processes on the Application Server workstation, along with the working state of each.



We recommend that you leave the AppServer Control window open and visible at all times to help you monitor the system. The following list describes the different working states that can appear on this window:

- **Green:** The process as a whole is running, although a sub-process may be paused.
- **Yellow:** The process has not finished starting up or shutting down, or the process is waiting for a subprocess to finish starting up or shutting down.
- **Red:** The process has stopped or did not start.

Once the Application Server is up and running, all of these processes should be green. If any of them are red or yellow, there is a problem with that process, and you should contact Cisco Services.

Some processes restart automatically in response to an error. If this happens, the status indicator cycles through red, yellow, and green as the process shuts itself down, restarts itself, and then becomes active.

## Application Server Processes Description

The following table provides a description of the processes on the Application Server that display in the AppServer Control window.

Process	Description
DHCT config server	DHCT Configuration Server. Generates the files containing the global, hub-specific, and staging configuration values for the Application Server; places the files on the BFS.
IPGServer-xxx	Interactive Program Guide Server. Generates the IPG file for a particular language xxx, for example “eng” for English, and places that file on the BFS.  <b>Note:</b> The languages available are English, French, Spanish, and Japanese.
ppvfileserver	Pay-per-view File Server. Generates PPV files for the Application Server and places those files on the BFS.
ppvServer	Pay-per-view Server. Receives PPV event definitions from the billing system and the PPV UI and stores them in the database. The ppvServer also notifies the ppvfileserver process when it is time for the ppvfileserver to generate updated files.
vcServer	Virtual Channel Server. Places the files for all configured virtual channels on the BFS.

## DNCS Administrative Console Window tabs

Each of the four primary tabs on the DNCS Admin Console provides access to specific functions.

You will use the Server Applications tab to provision applications. For more information on using the other tabs in DNCS processes, refer to the Digital Network Control System (DNCS) Online Help for your system release.

The following table describes the specific functions of the primary tabs on the DNCS Admin Console.

**Note:** The options that appear on these tabs vary depending on the optional features you have installed on your system.

Tab	Description
DNCS	Allows you to provision basic digital services and manage DBDS hardware on the DNCS.
Application Interface Modules	Allows you to set parameters for the DNCS to interact with DHCTs and service providers (for example, HBO or Internet services) to permit a smooth transfer of information between the service providers and DHCTs.

## Chapter 1 Introducing the Application Server

---

Server Applications	Provides access to applications that reside on the Application Server so that you can enable DHCTs to offer services associated with those applications to subscribers.  The options that appear on this tab vary depending on the applications available on your system.
Network Management	Provides access to network management windows, including the DHCT Monitor, so that you can monitor and manage activity on your system.

---

## Online Help

The DNCS Online Help provides additional information about a window or a particular procedure. This section describes the different ways you can access the DNCS Online Help.

### List Windows

You can view online help in one of the following ways:

- Click **Help**, then select **About DNCS** to view the main online help screen.
- Click **Help**, then select **This Window** to view help information about this window (if available).

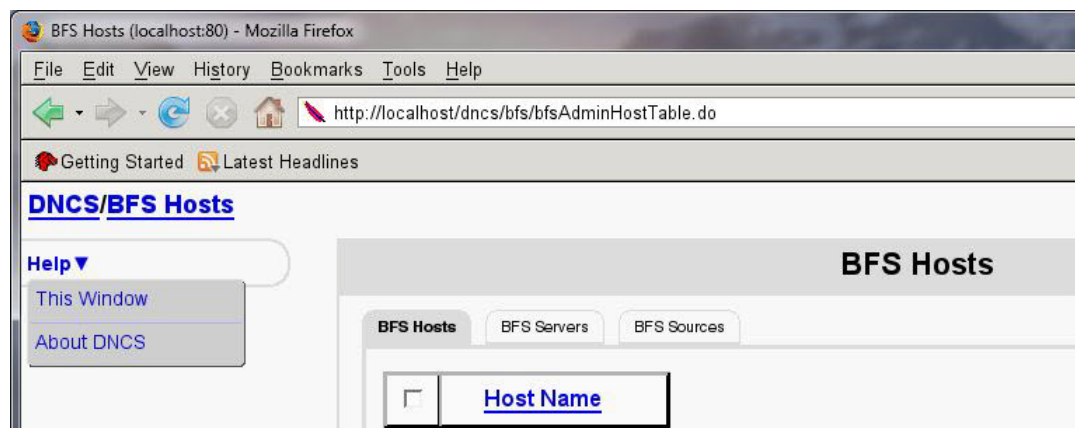

### Finding Information

You can use any of the following methods to find information you need in the DNCS Online Help:

- Click the topic in the **Contents** list
- Click the **Index** tab and type a keyword
- Click the **Search** tab and type a keyword
- Click the **Troubleshooting** topic in the Contents list for help resolving errors you may be experiencing
- Click the **Glossary** topic at the bottom of the Contents list for definitions of terms used throughout the Online Help

## Conventions

At the beginning of most procedures in the DNCS Online Help is a Quick Path for getting to a specific GUI window to perform the procedure. The following example shows the Quick Path for opening the Source Definitions List window.

**Quick Path:**  
DNCS Administrative Console > DNCS tab > System Provisioning tab > Source > [Source Name] > File > Source Definitions

As you become more experienced in using the DNCS, these Quick Paths may be the only reminders you need of how to perform certain tasks. In this example, you would use the Quick Path to perform the following steps.

- 1 On the DNCS Administrative Console, click the **DNCS** tab.
- 2 On the DNCS tab, click the **System Provisioning** tab.
- 3 On the System Provisioning tab, click **Source**. The Source List window opens.
- 4 On the Source List window, click once on the source name ([**Source Name**]) whose definition you need.
- 5 Click on the **File** menu, and then select **Source Definitions**. The Source Definitions List window opens for the source you selected.

## Navigation Tips

The following tips may help you to navigate more efficiently around the DNCS and the Online Help:

- To open a window for an existing item on the DNCS, the procedures in the Online Help advise you to click once on the item name; then, click **File** and select **Open**. In most cases, you can simply double-click on the item name to open the window, if you prefer.
- To return to a Help topic you have previously visited, click **Go** on your browser toolbar, and then choose **Back** from the drop-down menu that appears. You can also click the right mouse button in the Help topic window and select **Back** from the menu that appears.
- Occasionally, a Help page may not display properly. This is especially true if you try to resize the Help window. If this happens, simply close the Online Help and then re-open it.

## Search Tips

Entering a word or phrase in the Search tab and clicking Find explores the content of topics and finds all occurrences of the word or phrase. This method can help you find a topic (if you know its title) or every instance of a concept or feature in the system.

The following tips may help you to find topics more quickly:

- Searches are not case-sensitive. You can type your search in uppercase characters, lowercase characters, or a mix.
- You may search for any combination of letters (a-z) and numbers (0-9).
- To search for an exact phrase, surround the elements of your search with double quotes. For example, to search for information about the window Set Up BFS Host, enter "**Set Up BFS Host**" in the search field. This ensures that the system looks for this exact phrase. On the other hand, entering **Set Up BFS Host**, in the search field causes the system to look for topics that contain any of these four words.

## Printing Help Topics

If your system has print capabilities, you can print any Help topic by completing these steps.

- 1 Click once within the topic to select that area (frame).
- 2 Click **File** on your browser toolbar, and then select **Print Frame** from the menu.



# 2

---

## Getting Started

This chapter provides procedures for starting up the Application Server workstation and its processes. Use the procedures in this chapter if you are starting up the Application Server for the first time or if power to the Application Server has been interrupted.

Typically, the Application Server operates continuously until you stop it manually to upgrade it. If you are upgrading the Application Server, do not use the procedures in this chapter to restart the Application Server after the upgrade. Instead, use the procedures provided in the appropriate upgrade installation instructions for your system release.

### In This Chapter

- Power On the Application Server Workstation..... 14
- Start Application Server Processes..... 15

## Power On the Application Server Workstation

Before you power on the Application Server workstation, the DNCS processes must be running and you must have your login password. If you do not know your login password, consult your system administrator.

Complete these steps to power on the Application Server workstation.

- 1 Go to the Application Server workstation and press the **Power** button. The login window opens with a welcome message after a few minutes.

**Note:** If your system is not set up properly, the Application Server will not finish powering up. If your Application Server does not power on, contact Cisco Services at 1-800-283-2636.

- 2 Type the user name (typically **dncs**), and then press **Enter**. The password prompt appears.
- 3 Type the password, and then press **Enter**. The Application Server desktop appears. The Application Server workstation is now powered up.
- 4 Your next step is to start the Application Server processes. Go to *Start Application Server Processes* (on page 15).

## Start Application Server Processes

After you power on the Application Server workstation, you can start the Application Server processes. These processes are an integral part of the Application Server software. You cannot use the Application Server with the DNCS until you start these processes.

Complete these steps to start the Application Server processes.

- 1 Use the mouse to place the cursor anywhere on the Application Server desktop, and then click the middle mouse button. A drop-down menu appears with a list of options.
- 2 Click **App Serv Start**. The workstation front-panel "busy" light blinks to indicate that the software startup is in process.

## Monitoring Application Server Processes

If you want to monitor each Application Server process as it starts, complete these steps.

- 1 On the DNCS Administrative Console Status window, click the **Process Status** tab to view the Process Status window.

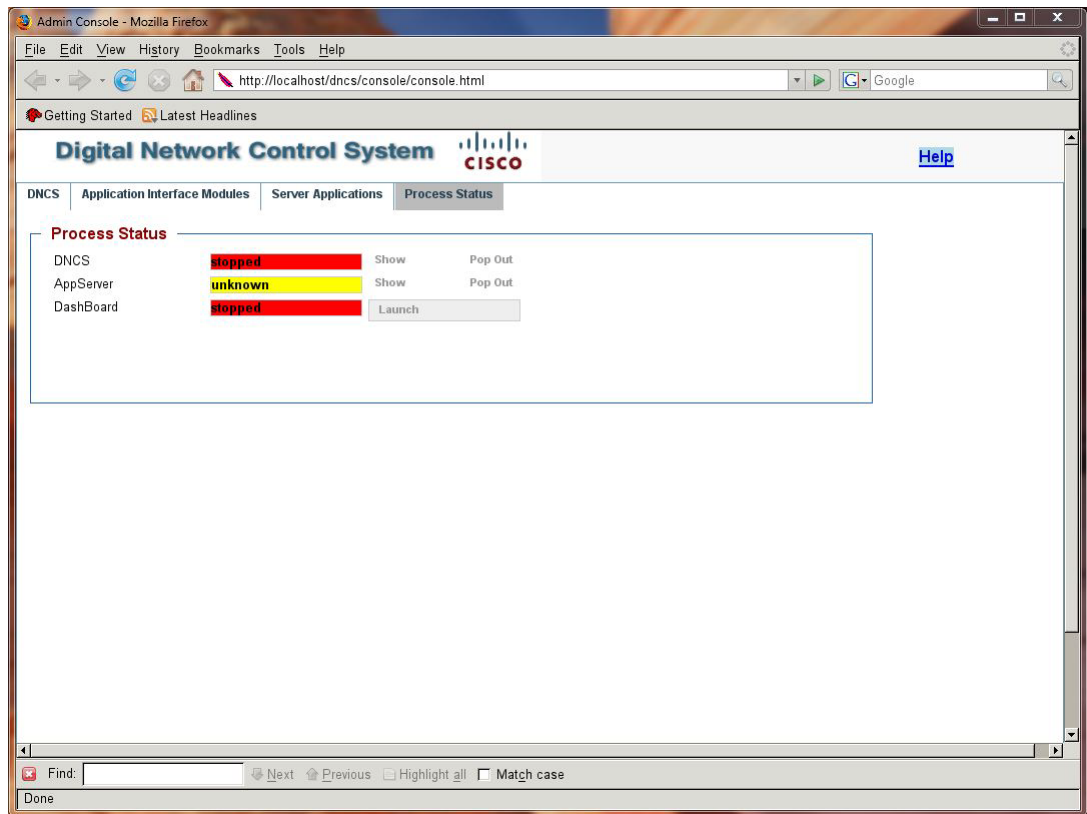

- 2 On the AppServer line, click **Pop Out**. The AppServer Control window opens and shows all Application Server processes and their working states, similar to the following example. A green state indicates that a process is running. A red state indicates that a process is not running.
- 3 Wait until all processes show a status of running (green), similar to the following example.

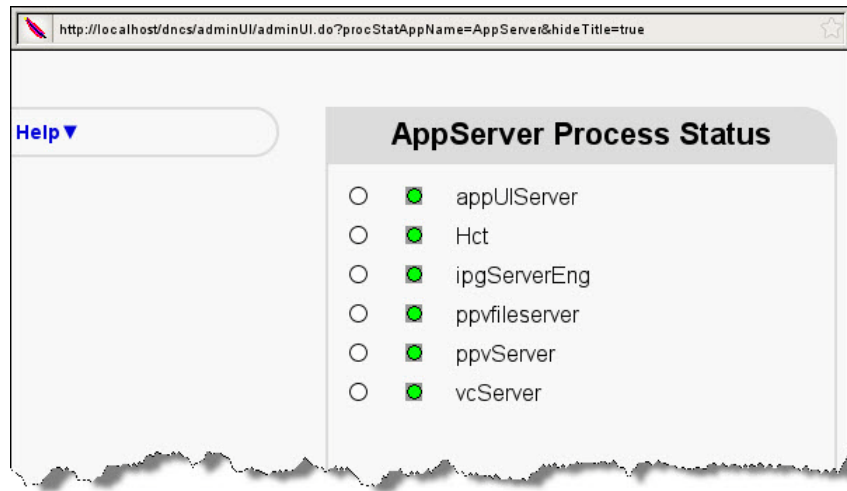

- 4 Leave this window open and visible to help you monitor the system.

## What's Next?

After you have verified that all of the processes are running properly, your next step is to set up the applications that you offer to your subscribers. For assistance, see the following chapters:

- Chapters 3 through 9 contain procedures for defining the applications you offer subscribers and changing the way the applications are configured.
- Chapter 10 contains procedures for enabling and disabling tracing on the Application Server.



# 3

## Setting Up Language Support

This chapter explains how to configure the DNCS to display the Interactive Program Guide (IPG) and PPV/IPPV event information menus in one of several languages.

**Important:** Configuring the DNCS for language support requires the following support from other vendors:

- To provide IPG in a different language, your data provider must provide programming information, such as titles in those languages.
- To provide PPV/IPPV titles in a different language, the billing system must provide this information as a part of the event definition.

### In This Chapter

- Set Up Supported Languages..... 20
- Configure Screen Language ..... 21
- One-For-All..... 24

## Set Up Supported Languages

To set up other languages for your IPG, use the Languages user interface located on the Server Applications tab of the DNCS Administrative Console. For each language that you set up, there must be an IPG server and an IPG collector to support the language. The DNCS allows one IPG server per active language. You must complete the following tasks when setting up supported languages.

- 1 Verify and select the appropriate languages your system supports.
- 2 Create a server and a collector for each language you select.

For procedures to create a server and a collector, see *Setting Up the Interactive Program Guide* (on page 59).

## Verifying and Selecting the Appropriate Languages

Perform the following steps to verify that the DNCS recognizes the languages your DBDS supports.

- 1 On the DNCS Administrative Console, select the **Server Applications** tab.
- 2 Click **Languages**. The Supported Languages window opens.



**Note:** Standard DHCT code supports English, French, and Spanish. Special DHCT code is required to support Japanese and Arabic.

- 3 Be sure that the languages your DBDS supports are selected.

**Note:** In the example in step 2, only English is selected. However, if your system supports other languages, select those options as well, and then click **Save**.

- 4 Click **Save** to save your changes, then click **Cancel** to close the window.

## Configure Screen Language

Language set on the Application Server is shown on the screen and is called the "screen language." Screen Language can be configured as either a global or an addressable feature.

On the General Settings tab in the Global Configuration window, you can use **Language: Screen** to determine whether the Screen Language feature should be an Addressable option (meaning that the subscriber can change it from the set-top menu) or a Global option (meaning that you will set it in the headend for all subscribers).

When checked, the **Language: Screen** option enables **Addressable** configuration. When unchecked, the **Language: Screen** option enables **Global** configuration.

The screenshot shows the Cisco DNCS/DHCT Configure interface. The main window is titled "Set Up Global DHCT Configuration". On the left, there is a navigation menu with links for "Addressable", "Staging Defaults", "Global", "Hub", "Select Hub-Specific Items", and "Help". The main content area has a header "Set Up Global DHCT Configuration" and a sub-header "General Settings". Below the header, there are tabs for "Base Application", "PIN Entry", "General Settings", "Barkers", "Quick Settings", "IPPV", "Misc Settings", and "IPG". The "General Settings" tab is selected. Under "General Settings", there is a section for "VCR Commander Menu Option" with radio buttons for "Addressable" and "Global". The "Global" option is selected. Below this is a section for "User Menu Options" with a grid of checkboxes. The "Language: Screen" checkbox is checked and highlighted with a red box. Other checkboxes include "AC Outlet Control", "Audio: Digital Output", "Audio: Range", "Audio: Volume Control", "Block: Rating", "Block: Time", "VCR Commander", "Bypass When Off", "Display: Power Off", "Language: Audio", "Language: Keyboard", "LED Channel Switch", "Power On Channel", "RF Output Channel", "Set: Color Scheme", "Timer: All", "DVS Support", and "Power On Keys". At the bottom, there is an "Options" section with checkboxes for "Numeric Key Chooses Channel" and "Numeric Key Sets Times". "Save" and "Cancel" buttons are at the bottom of the window.

## Global Configuration

The Global configuration affects all the set-tops in the network.

- Screen Language is set from the Application Server.
- Screen Language is not displayed in General Settings on the set-top box.

If **Screen Language** is a Global Configuration, the **Screen Language** drop-down list appears on the Base Application tab of the Global configuration window, but it does *not* appear on the Base Application tab of the Addressable or Staging configuration windows.

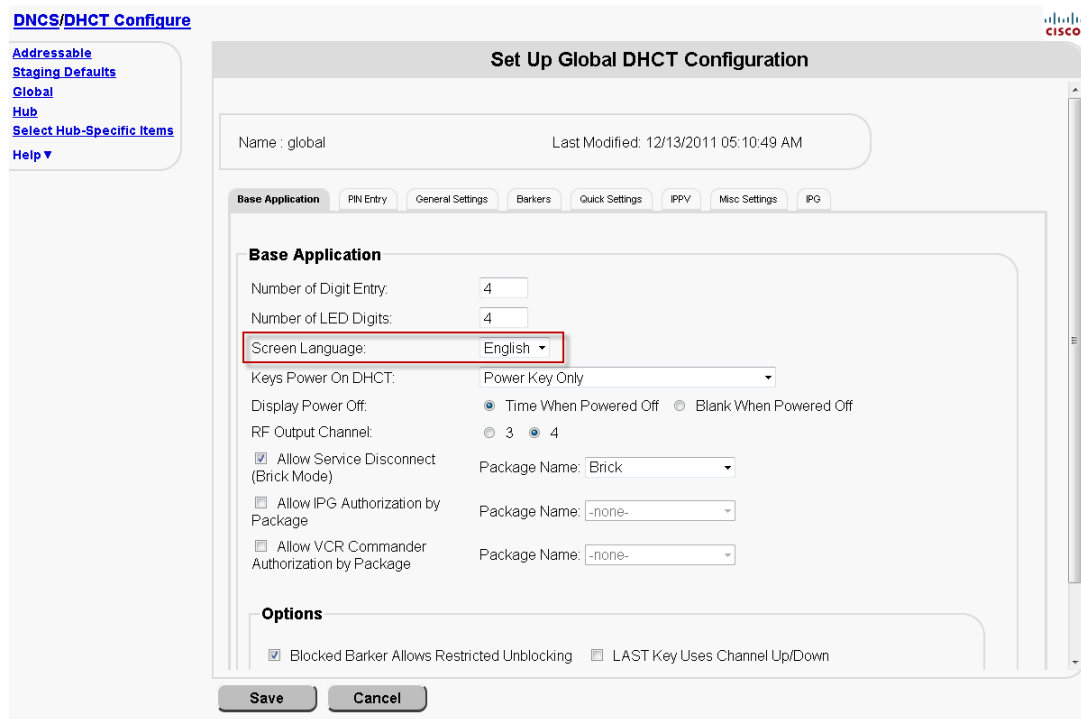

## Changing from Addressable to Global Configuration

You can change **Screen Language** from an Addressable configuration to a Global configuration.

- 1 From Set Up Global DHCT Configuration in the General Settings tab, ensure the Screen Language feature is unchecked. This enables the Global configuration.
- 2 The Screen Language option is no longer displayed in the General Settings menu on each set-top box.

**Note:** Until the Global configuration is reconfigured from the server, the Addressable configuration value will be used. After the server is reconfigured and the Global configuration is set, it will override any Addressable configurations.

## Addressable Configuration

The Addressable configuration affects individual set-tops. Screen Language can be set from the set-top General Setting Menu.

**Note:** If the Global configuration is set, it will override any Addressable configurations.

If **Screen Language** is an **Addressable** and Staging Configuration, the **Screen Language** combo list appears in the Base Application of Addressable and Staging Configuration and does **not** appear in the Base application of Global configuration.

## Changing from Global to Addressable Configuration

If **Screen Language** is configured as **Global**, it can later be changed to an Addressable configuration.

- 1 From the Global/General Settings tab, ensure the Screen Language feature is checked. This enables the Addressable configuration.
- 2 The Screen Language option is now displayed in the General Settings menu on each set-top box.

**Note:** The original, Global configuration value will be used until the Screen Language option in General Settings is reconfigured from each set-top box.

## One-For-All

One-For-All is a feature that checks to see if PPV event descriptions are available in more than one language in an attempt to avoid showing the text "No description available."

### Background

The IPG lists PPV events by title. Subscribers also want to see a PPV event summary called a description but unfortunately, service providers do not supply descriptions in all languages. When a description is not available in the IPG language, subscribers see the text "No description available."

### PPV Event Descriptions Without One-For-All

Without One-For-All, the Application Server populates the IPG with PPV event descriptions available in the screen language.

**Note:** The language set on the Application Server is called the *screen* language. For more details, see *Configure Screen Language*.

The following table shows that if the screen language is English and the PPV event description is English, then subscribers will see the English description. If the screen language is English and the PPV event description is not English, then subscribers will see the text "No description available."

Screen Language Set on the Application Server	Event Description Available in Screen Language?	This Description is Populated in an IPG without One-For-All
English	Yes	Description in English
French	Yes	Description in French
English	No	<b>No description available</b> in English
French	No	<b>No description available</b> in French

### PPV Event Descriptions With One-For-All

One-For-All is a strategy to show PPV event descriptions, even if the description is not offered in the screen language. To enable One-For-All, the operator sets a default language in the .profile file. For directions, see *Configuring One-For-All* (on page 25).

**Note:** The language set in the .profile is the *default* language. Since this is an alternate language to check for a description, the operator must set a language in the .profile that is different from the screen language and which may have a description available.

Every time a description is not available in the screen language, One-For-All triggers the Application Server to look for a description in the default language. If a description is available in the default language, then the Application Server will populate the IPG with a PPV event description in the default language.

For instance, the following table shows that sometimes the PPV event description is *not* available in the screen language but the PPV event description *is* available in the default language. If, for example, English is the screen language and French is the default language, and the PPV event description is *not* available in English but *is* available in French, then subscribers will see the PPV event description in French.

Finally, if the PPV event description is not available in either the screen language or the default language, then subscribers will see the text "No description available."

Screen Language Set on the App Server	Description Available in Screen Language?	Default Language Set in the .profile	Description Available in Default Language?	This Description is Populated in an IPG with One-for-All
English	No	French	Yes	Description in French
French	No	English	Yes	Description in English
English	No	French	No	<b>No description available</b> in English
French	No	English	No	<b>No description available</b> in French

**Note:** French and English have been used in these tables as arbitrary examples. IPG data is available in English, French, Spanish, and in Japanese for SR 4.0, 4.2 and later, and in Arabic for SR 4.3 and later.

## Configuring One-For-All

Complete these steps to configure One-For-All.

- 1 Open an xterm window on the Application Server.
- 2 Type `cd /export/home/dncs` and press **Enter**. The `/export/home/dncs` directory is now the working directory.
- 3 Type `vi .profile` and press **Enter**. The vi editor opens the `.profile` file for editing.  
**Note:** Be sure to type a period (.) before the word "profile."
- 4 Use the arrow keys to move to the bottom of the file.
- 5 Type `o`. A new line appears at the end of the file.
- 6 Type the following lines at the end of the file and press **Enter** after each line.  
`PPV_DEFAULT_LANGCODE="<language>";`  
`export PPV_DEFAULT_LANGCODE;`

Examples (English, French, Spanish, Japanese and Arabic):

```
PPV_DEFAULT_LANGCODE="eng";  
PPV_DEFAULT_LANGCODE="fra";  
PPV_DEFAULT_LANGCODE="spa";  
PPV_DEFAULT_LANGCODE="jpn";  
PPV_DEFAULT_LANGCODE="ara";
```

**Important:** Ensure that the PPV\_DEFAULT\_LANGCODE you set (the "default language") is different from the Application Server language (the "screen language"), and is likely to be used for a PPV event description. For more about the screen language, see *Configure Screen Language*.

**Notes:**

- Currently, five language options are available. In order to set the default language to English, type "eng". For French, type "fra". For Spanish, type "spa".
- Japanese "jpn" is available for SR 4.0, 4.2 and later.
- Arabic "ara" is available for SR 4.3 and later.

- 7 Press **Esc**.
- 8 Type **:wq** and press **Enter**. The vi editor saves and closes the .profile file.
- 9 On the Application Server, you must stop and restart the PPV processes to activate these new values. See *Stopping and Restarting a Server Process* (on page 68) for more information.

# 4

## Setting Up Described Video Services

Described Video Services (DVS) is an audio track feature that describes video to aid the visually-impaired. It provides visually impaired viewers with audio descriptions of key elements in a program, such as what is happening on the screen, during pauses in the dialogue.

This chapter explains how to configure the system to support DVS.

### Important:

- DVS support is not enabled by default.
- The following versions of client software are required to support the features provided with this version of application server software.

Application Server Platform	Client Software
4250SD/HD	PowerKEY® 5.3.1
8300SD/HD DVR	DVR 1.7.0
8500SD/HD DVR	DVR 1.7.0

Follow these guidelines when you enable DVS support:

- Do not enable this option unless you are familiar with DVS and your content is encoded with DVS audio streams.
- Remember that obtaining and providing audio streams is the responsibility of the operator.
- Check that DVS audio streams are encoded within an MPEG program.
- Source definition and session configuration must be set up to carry the DVS PID (Program ID).

## In This Chapter

- Enable DVS Support..... 29
- Configure DVS Support..... 33

# Enable DVS Support

## Overview

Setting up DVS support is a two-step process:

- 1 Enable DVS Support on the System
  - **Global configuration:** Enable DVS support on the system
  - **Hub configuration:** Enable or disable DVS support for specific hubs on the system
- 2 Configure DVS Support on the Set-Top
  - **Staging defaults configuration:** Configure DVS support during the staging process, so that all set-tops receive the same configuration when they are staged
  - **Addressable configuration:** Configure DVS support on a single set-top, identified by MAC address
  - **Subscriber configuration:** The subscriber can configure and enable or disable DVS support

For more information about configuring DNCS settings, refer to *Enhancing Your Subscribers' Experience: SARA Configurable Options* (part number 4002178).

## Enabling Global DVS Support

The parameters that you set in the **Set Up Global DHCT Configuration** window affect the parameters that are available in the Addressable, Hub, and Staging Defaults windows.

When DVS support is globally enabled, the **Audio:Described** option is visible on the Addressable/Staging and on hub configurations. When DVS support is disabled, set-tops do not show the **Audio: Described** option in General Settings on the UI.

### Important:

- Once DVS support has been enabled globally, support must be configured on the set-tops before subscribers can enjoy DVS.
- Global settings for DVS support override individual set-top settings.

Follow these steps to enable DVS support on all the set-tops in your network.

- 1 On the DNCS Administrative Console, select the **Server Applications** tab.

- 2 Click **DHCT Config**. The DHCT Configure window opens.

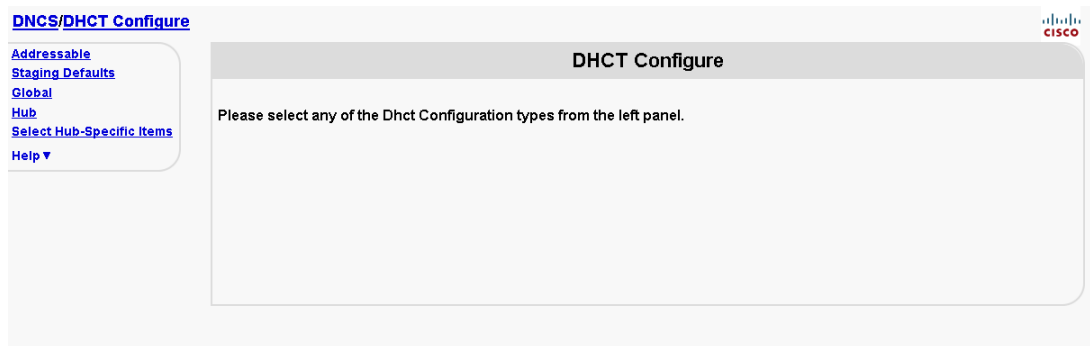

- 3 Click **Global**. The Set Up Global DHCT Configuration window opens.
- 4 Click the **General Settings** tab.
- 5 Be sure that **DVS Support** in the User Menu Options area is checked, as shown in the following example:

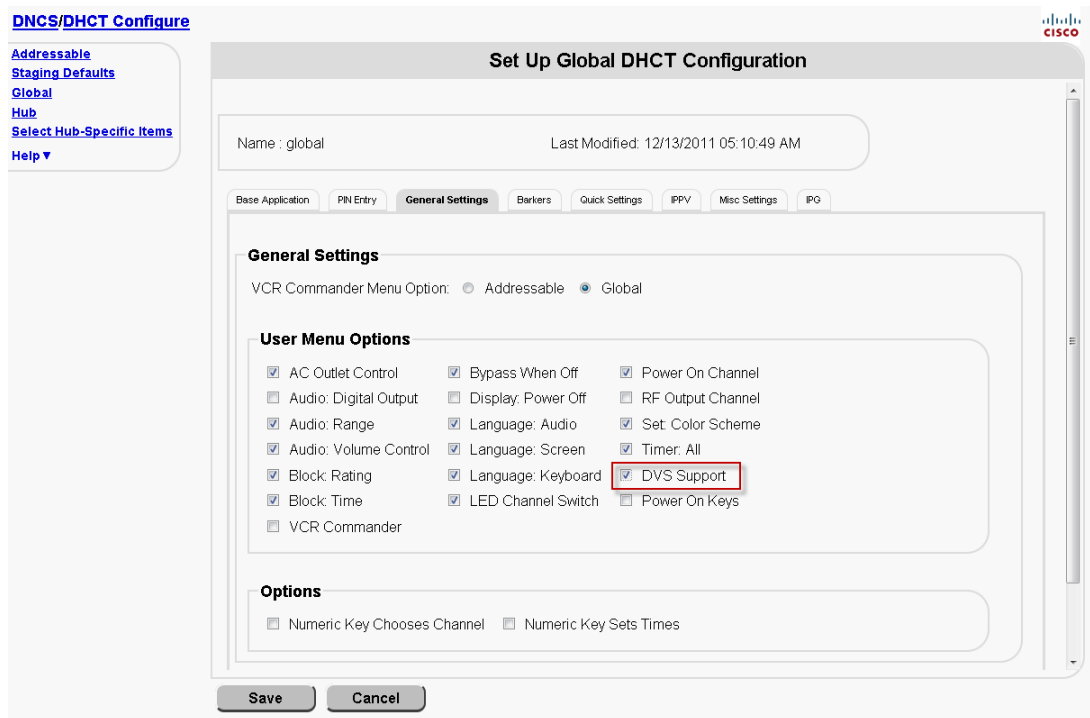

- 6 Click **Save** to save your changes, then click **Cancel** to close the window. Support for DVS has now been activated on your DNCS.

## Enabling and Disabling DVS Support on a Hub

DVS can be selectively enabled or disabled on hubs. DVS support settings at the hub level will override the global configuration.

**Important:** DVS support must be enabled globally before the hub can be configured. If you have not enabled DVS support on the system, return to Enabling Global DVS Support before you attempt the following steps.

When setting Hub-level control of DVS support, you will first enable DVS support in the UI. Then you can choose to enable or disable DVS support on the hub.

#### Enable the DVS Support in the User Interface

- 1 On the DNCS Administrative Console, select the **Server Applications** tab.
- 2 Click **DHCT Config**.
- 3 In the DHCT Configure window, choose **Select Hub-Specific Items**.
- 4 In the Select Hub-Specific Items window, click the **General Settings** tab.
- 5 Click the DVS Support check box in the User Menu Options area to enable DVS support on the hub or ensure the check box is empty to disable DVS support on the hub, as shown in the following example:

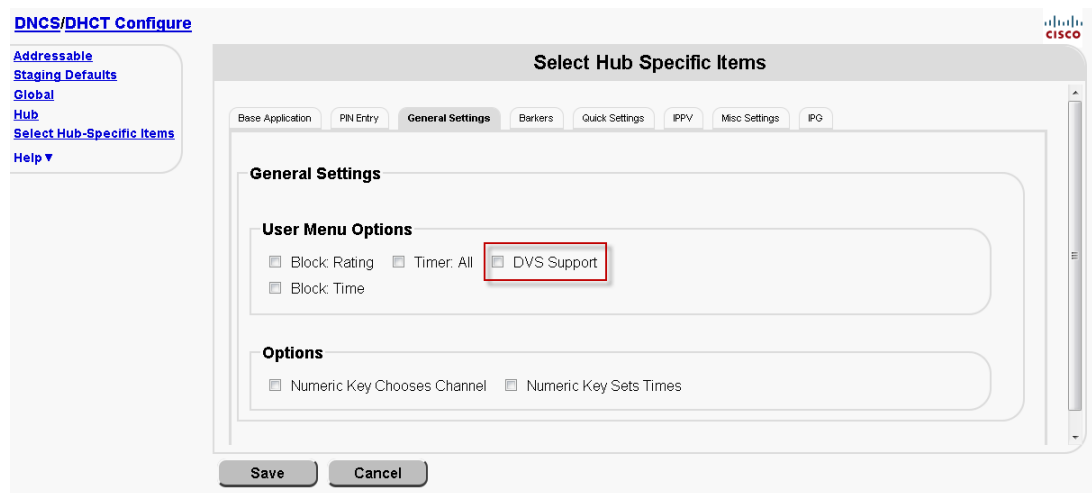

- 6 Click **Save** to save your changes, and then click **Cancel** to close the window.

#### Enable or Disable DVS Support on a Specific Hub

- 1 On the DNCS Administrative Console, select the **Server Applications** tab.
- 2 Click **DHCT Config**.
- 3 In the DHCT configure window, click **Hub**.
- 4 Click **New Hub-Specific**.
- 5 In the New Hub-Specific Items window, click the **General Settings** tab.

- 6 Click the **DVS Support** check box in the User Menu Options area to enable DVS support on the hub or ensure the check box is empty to disable DVR support on the hub, as shown in the following example:

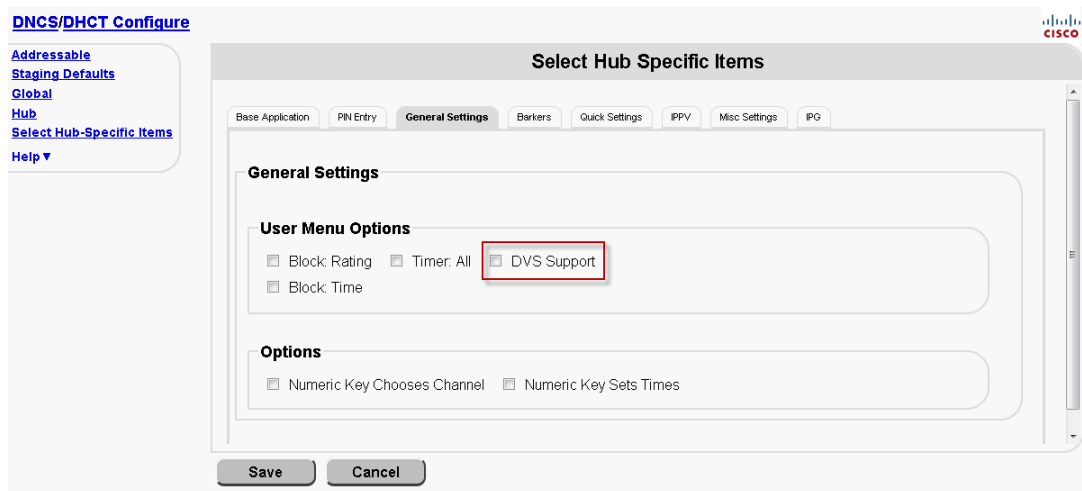

- 7 Click **Save** to save your changes, and then click **Cancel** to close the window. The Application Server sends the configuration to all the set-tops in the hub that you specified. Changes should be available on each set-top in a few minutes.

**Note:** After you send a hub-specific configuration, any changes that you make to the global configuration do not affect the hub-specific settings. From now on, if you need to change an option that affects all of the set-tops in your network, you will need to make this change in the global configuration **and** in the hub-specific configurations for any hubs that require this change.

## Configure DVS Support

After you enable DVS support on the system, you must configure the set-tops.

### Configuring DVS Support During Staging

Set-tops (unless specifically configured) are configured for DVS support during staging.

**Note:** The staging value for DVS support (enabled or disabled) is used by the set-top when it first connects to the network or when `nvm clear` is performed on the set-top.

Follow these steps to configure DVS support on set-tops during the staging process.

- 1 On the DNCS Administrative Console, select the **Server Applications** tab.
- 2 Click **DHCT Config**. The DHCT Configure window opens.
- 3 Click **Staging Defaults**.
- 4 In the Set Up Staging Defaults window select the **Base Application** tab.
- 5 Select the **Audio: Described** checkbox from the Options area:

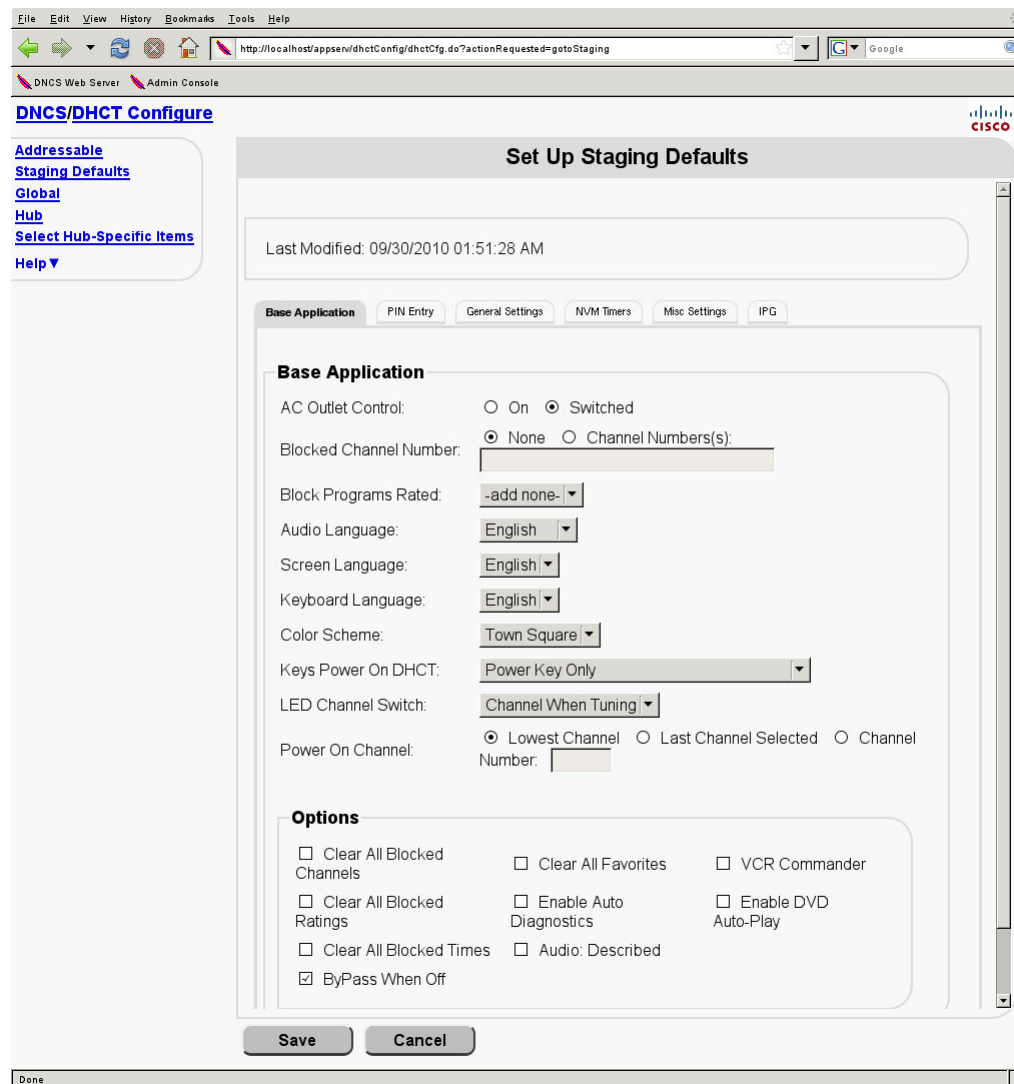

- Click **Save** to save your changes, then click **Cancel** to close the window. DVS support has now been successfully configured on your set-tops.

## Configuring DVS Support on a Single Set-Top

Set-tops can be configured individually for DVS support from the network headend. Once staged, a specific set-top identified by a MAC address can be enabled or disabled.

**Important:** Addressable configuration information is not stored on the Application Server. The set-top must be plugged in and functional to receive the addressable configuration message.

Follow these steps to configure DVS support on a single, addressable set-top.

- On the DNCS Administrative Console, select the **Server Applications** tab.
- Click **DHCT Config**. When the DHCT Configure window opens, click **Addressable**.

- On the Set Up Addressable DHCT Configuration window, select the **Base Application** tab. Type the MAC address of the set-top that needs DVS enabled in the **DHCT MAC Address** field at the top of the page.

**Note:** You must provide the MAC address when configuring a single set-top.

- Click the **Audio: Described** checkbox in the Options area.

The screenshot shows the 'Set Up Addressable DHCT Configuration' window. The 'Base Application' tab is active. The 'DHCT MAC Address' field is empty. The 'Last Modified' timestamp is '09/30/2010 01:51:28 AM'. The 'Base Application' section has the following settings: AC Outlet Control:  On  Switched; Blocked Channel Number:  None  Channel Number(s); Block Programs Rated: -add none-; Audio Language: English; Screen Language: English; Keyboard Language: English; Color Scheme: Town Square; Keys Power On DHCT: Power Key Only; LED Channel Switch: Channel When Tuning; Power On Channel:  Lowest Channel  Last Channel Selected  Channel Number. The 'Options' section has the following checkboxes:  Clear All Blocked Channels,  Clear All Blocked Ratings,  Clear All Blocked Times,  ByPass When Off,  Clear All Favorites,  Enable Auto Diagnostics,  Audio: Described,  VCR Commander,  Enable DVD Auto-Play. At the bottom are 'Send', 'Clear', 'Reset', and 'Cancel' buttons.

- Click **Send**. The status message, "Configuration sent" appears at the bottom of the window to confirm the new setting.
- Click **Cancel** to close the Set Up Staging Defaults window. Support for DVS has now been successfully configured on the set-top.

## Subscribers Configure DVS Support

Set-tops can be configured and enabled or disabled by subscribers from the set-top UI. Subscribers must follow these steps to enable DVS on their set-top.

## Chapter 4 Setting Up Described Video Services

- 1 Navigate to the **General Settings** menu.
- 2 Select **Audio: Described**.
- 3 Use the arrows on the remote control to select **Enabled**.

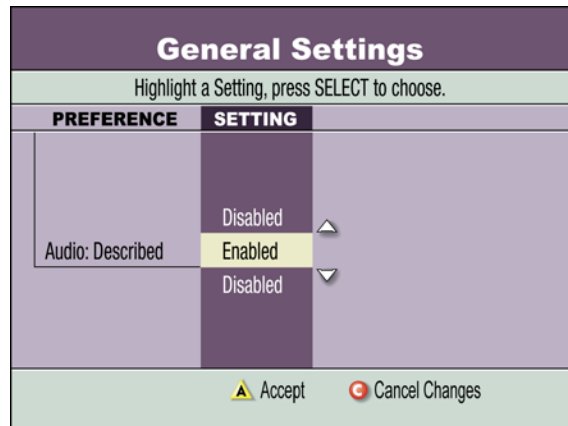

## Subscribers Quick Settings DVS Experience

When DVS support has been activated, subscribers will notice a change in the **Choose Language** option in their Quick Settings menu. Available languages will be identified with a "DVS" precursor (such as **DVS:English** in the following example).

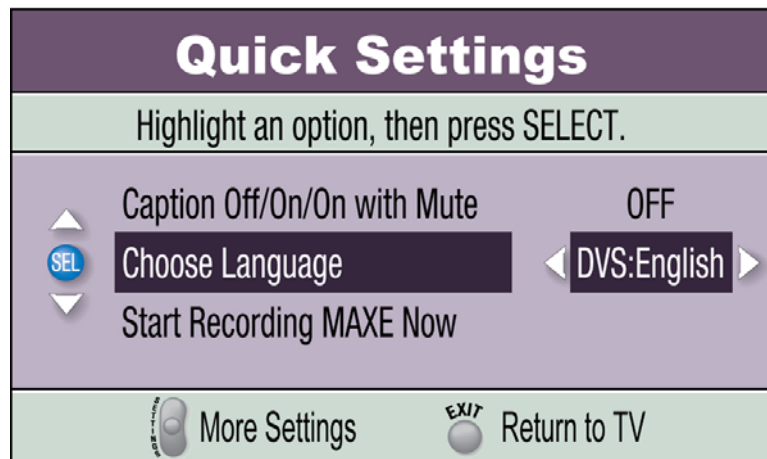

For more information about the user interface, see *Set Up the IPG* (on page 64).

# 5

---

## Defining PPV Services and Events

This chapter explains how to define PPV services and events. It also describes the purpose of windows and barkers.

### In This Chapter

- Define PPV Services ..... 38
- Understand Windows and Barkers ..... 45
- Define PPV Events ..... 50

## Define PPV Services

This section explains how to create, modify, and delete PPV services.

### Before You Begin

Before you can define PPV events for subscribers to purchase, you must define the PPV services that will deliver these events. A *PPV service* is an application that allows subscribers to purchase movies, concerts, or sporting events and view them at a certain time on a certain channel. A *PPV event* is any program (such as movie, concert, or sporting event) that a subscriber can purchase through a PPV service. If a subscriber has purchased the event that is currently playing on the PPV service, then the PPV service displays that event. If not, then the PPV service displays advertising, interstitials, or some other programming.

As with other services, you must complete the following tasks when defining a PPV service:

- **Add the service source to the DNCS.** This task specifies which digital or analog signal the DBDS will use to deliver the service to subscribers.
- **Define parameters for the service source.** This task defines the attributes that establish how the system will process service content. Also, this task includes building a session, which defines and allocates the resources that the source will use to deliver the service content.
- **Encrypt the content coming from the service source.** This task ensures that the content will only be available to authorized subscribers.

Before you can define PPV services, the service on which a PPV service is built must be registered with the Service Application Manager (SAM), Event Use Service, Subscription Service (if used), and Interstitial Service. These are described in more detail later in this section. The SAM is a table that identifies available services and their associated applications. The DNCS automatically registers the service with the SAM when you create the service, so you do not need to register an event's service with the SAM.

## Understanding the Add PPV Service Window

Use the Add PPV Service window to create or modify PPV services.

The screenshot shows the 'Add PPV Service' window with the following fields and values:

- Service ID: (empty)
- Service Name: (highlighted in yellow)
- Short Description: (empty)
- Long Description: (empty)
- Logo Index: (empty)
- Default Order Phone Number: (empty)
- Default Cost: (empty)
- Default Order Start Interval: 0 Hours 0 Minutes
- Event Use Service: DIG2000
- Subscription Service: - none -
- Interstitial Service: - none -

Buttons at the bottom: Save, Cancel

The fields on this window are as follows:

- **Service Name:** A unique name for the service, typically provided by the billing system.
- **Short Description:** A useful descriptive short name, such as IPPV1 and IPPV2 for subscribers when they tune to the channel where this PPV service resides
- **Long Description:** A longer description that provides a more complete definition of the service. This is for your benefit only. Subscribers never see the information entered here
- **Logo Index (Optional):** A number that associates a graphic with the PPV service. You can obtain a list of logo numbers from your account representative
- **Default Order Telephone Number:** Specifies the phone number for subscribers to call to order a reservation pay-per-view (RPPV) event advertised by this service. The number you enter displays for subscribers unless the billing system provides another telephone number. Type this phone number exactly as it should appear on the TV screen (including dashes and parenthesis, if appropriate)
- **Default Cost (Optional):** Sets the default cost for events on the service if no cost is specified for the event. Type this amount exactly as it should appear on the TV screen (including a dollar sign and decimal point, if appropriate)
- **Default Order Start Interval (Optional):** Specifies a default interval during

which subscribers can call to order an event, if the event definition does not specify when subscribers can order the event. For example, suppose the Default Order Start Interval is 12 hours and 0 minutes. If an event does not specify an order start time, then subscribers can begin calling to order the event 12 hours before the event begins. Type this amount in hours and minutes

- **Event Use Service:** The service that will be seen on this PPV service when PPV events are purchased. Click the arrow to display a list of all services available, and then select the appropriate service from the list
- **Subscription Service (Optional):** Specifies whether this service will function as a subscription service in addition to a PPV service
  - If you want the service to function as a PPV service, click the arrow and select **none**
  - If you want the service to function as a subscription service (one that is always available to authorized subscribers), click the arrow and select the same service you selected in the **Event Use Service** field
- **Interstitial Service (Optional):** A specific service that displays between events; this service could be general programming or an advertisement. Click the arrow and select from the list of existing services. If you do not specify an interstitial service, the PPV service channel will display a standard text barker between events

## Creating a PPV Service

After you have built the services, the next step is to create a service that advertises and sells the events: a PPV service.

Complete these steps to create a PPV service.

- 1 On the DNCS Administrative Console, select the **Server Applications** tab.

- 2 Click **PPV Service**. The PPV Service List window opens, similar to the following example.

<input type="checkbox"/>	Service Name	Short Description
<input type="checkbox"/>	jeffservice	jeffs
<input type="checkbox"/>	Test	test

Buttons: Add, Edit, Delete

- 3 Click **Add**. The Add PPV Service window opens, similar to the following example.

Service ID:

Service Name: [highlighted]

Short Description: [text box]

Long Description: [text box]

Logo Index: [text box]

Default Order Phone Number: [text box]

Default Cost: [text box]

Default Order Start Interval: 0 Hours 0 Minutes

Event Use Service: DIG2000

Subscription Service: - none -

Interstitial Service: - none -

Buttons: Save, Cancel

- 4 On the **Add PPV Service** window, complete all of the following required fields. Optional fields are labeled. See *Understanding the Add PPV Service Window* (on page 39) for descriptions of these fields.

**Note:** Be sure to make a note of the values in the Short Description field and the Event Use Service field. You will need these values when you set up this PPV service on the IPG.

- Service Name

- Short Description
  - Long Description
  - Logo Index (Optional)
  - Default Order Telephone Number
  - Default Cost (Optional)
  - Default Order Start Interval (Optional)
  - Event Use Service
  - Subscription Service (Optional)
  - Interstitial Service (Optional)
- 5 Click **Save** to save your changes, and then click **Cancel** to close the window. The Application Server creates a PPV service for the source and automatically does the following:
- Registers the service with the SAM
  - Assigns a URL of ippv to the service
  - Makes the service available to the channel maps
  - Creates an unlimited segment from the service, which you can view in the Segment List
- Note:** For each PPV service there are two SAM services: the PPV service and the Event Use service. You must map both the PPV service and the Event Use service to the IPG Service List to ensure that data about the events appears in the IPG and on the purchase barkers.
- 6 Do you want to add another PPV service?
- If **yes**, go back to step 3 and add the next service.
  - If **no**, add all of the PPV services that you created and all of their Event Use services to the IPG Service List. For assistance, go to *Set Up the IPG* (on page 64) and follow the instructions.
- 7 Add all of the PPV services that you created to the channel map. Refer to the online help for procedures to complete this task.
- 8 Does your system support Explorer® 3100HD DHCTs?
- If **yes**, ensure that the SAM URL of any PPV service that contains high-definition (HD) content includes the HD flag. If this flag is absent in HD content, 3100HD DHCTs cannot display PPV barkers and other graphics over HD content. As a result, full-screen HD content displays over PPV preview graphics and enables subscribers to receive the entire HD event for free. For assistance adding the HD flag to the SAM URL of HD PPV services, refer to *Enhancing Your Subscribers' Experience: SARA Configurable Options* (part number 4002178).

**Note:** The HD flag (;HD) must be attached to the end of the SAM Service URL (on the Set Up SAM Service window) as shown in this example:  
bfs://resapp/watchtv;HD.

- If **no**, you have completed defining PPV services. For a better understanding of how PPV events are offered to subscribers, see *Understand Windows and Barkers* (on page 45).

## Modifying PPV Services

Complete these steps to modify a PPV service.

- 1 On the PPV Service List window, click to select the service you want to modify.
- 2 Click **Edit**. The Edit PPV Service window opens, similar to the following example.

The screenshot shows a web browser window with the address bar displaying 'http://localhost:appserv/ppvservices/PPVServiceList.do'. The page title is 'DNCS/PPV Service List/Edit PPVService'. The main content area is titled 'Edit PPV Service' and contains a form with the following fields:

- Service ID: 266
- Service Name: asd
- Short Description: ppvTe
- Long Description: jhsfdj
- Logo Index: 3
- Default Order Phone Number: #12
- Default Cost: (empty)
- Default Order Start Interval: 0 Hours 0 Minutes
- Event Use Service: HALLMARK
- Subscription Service: - none -
- Interstitial Service: - none -

At the bottom of the form are 'Save' and 'Cancel' buttons. The browser's status bar at the bottom shows 'Done'.

- 3 Make necessary changes in the fields, and click **Save**.

## Deleting a PPV Service

Complete these steps to delete a PPV service.

**Important:** The system will not allow you to delete a service if events also use the service.

- 1 Select the service you want to delete in the PPV Service list window.

## Chapter 5 Defining PPV Services and Events

- 2 Click **Delete**. A message prompts you to confirm that you want to delete the current item.
- 3 Click **Yes** to confirm that you want to delete the PPV service.

## Understand Windows and Barkers

PPV events are available for viewing during a specified period of time. This period of time is called a window. The period of time that a window is present determines when the PPV service displays a specific type of advertisement or purchase option. These advertisements and purchase options are presented by screens called barkers.

This section describes the types of windows and barkers used in offering PPV events to subscribers. You must understand the relationship between windows and barkers in order to define PPV events successfully.

**Note:** Remember, a window is a period of time. A barker is a screen that advertises an event or allows a subscriber to order an event.

### Windows

PPV services use six different types of windows to offer events to subscribers. Some windows are used for both RPPV and impulse pay-per-view (IPPV) events, and some are used for IPPV events only. The following table describes the different windows and the associated PPV event.

Type of Window	Purpose
Event Window	This window defines the period of time that video is shown on the PPV service channel. The event's start time and length determine this time period.
Marketing Window	This window defines the period of time that the PPV service can advertise the event. During the Marketing window, a Purchase Prompt barker appears when the subscriber sets a reminder or VCR timer for the event. This also allows subscribers to purchase an IPPV event from the IPG.  <b>Important:</b> The Marketing Window should be at least as long as the number of days of IPG data you provide (typically seven days).
Advertising Window	This window defines the period of time that the Purchase barker appears when the subscriber is tuned to the PPV service channel. Each PPV service may have only one Advertising window open at a time.
Preview Window	This window defines the period of time that a subscriber may view the IPPV event on the PPV service channel without purchasing the event. During this time, if the subscriber has not purchased the event, the Preview barker appears. When a subscriber purchases the event, the event appears.

Type of Window	Purpose
Buy (GBAM) Window	This window defines the period of time that the PPV service will attempt to verify IPPV event purchases. If the PPV service verifies the purchase, the subscriber will see the event. (The Buy window uses a Global Broadcast Authenticated Message [GBAM] to verify a purchase.)
Cancel Window	This window defines the period of time that a subscriber may cancel an IPPV event purchase.

## Window Relationships

There are some timing requirements that you must follow when setting up PPV windows. If you do not follow these requirements, then subscribers may not be able to purchase PPV events successfully. For example, if you do not define an Advertising window correctly, then the Purchase barker will not appear when subscribers tune to the PPV service channel. In this case, subscribers are unable to purchase the event. Or, if you do not define the event itself correctly, then the event will not appear as expected.

In examining the window relationships in the following illustration, remember that the billing system defines these windows when it sends the event definition to the Application Server. Therefore, in most cases you should not need to define an event (although you can do so manually if necessary.) You can view the Set Up PPV Event window to view the window definitions for an event.

**Note:** For IPPV events, you must define the Marketing, Advertising, Buy (GBAM), and Event windows. For RPPV events, you only need to define three windows: the Marketing, Advertising, and Event windows.

**Default Start = 24 hours before event start**  
**Marketing Window \***  
 Must open before event starts and close before event ends.  
 The event phone number must be active after the marketing window opens.  
 Day 1 (1:00 AM) Day 11 (8:00 PM)

**Default Start = 15 minutes before event start**  
**Advertising Window \***  
 Must be contained within the Marketing Window.  
 The Advertising Window must close before the Buy Window closes.  
 Day 11 (6:45 PM) Default End = 45 minutes after event start Day 11 (7:45 PM)

**Buy (GBAM) Window**  
 Must be open at least 5 minutes before event starts.  
 Day 11 (6:55 PM) Day 11 (7:50 PM)

**Preview Window \***  
 Must be contained within the Advertising Window.  
 Day 11 (7:00 PM) Day 11 (7:30 PM)

**Cancel Window**  
 Must open before event starts.  
 Day 11 (7:00 PM) Day 11 (8:00 PM)

**Event Window \***  
 Event must be set up on billing system 30 minutes before the Advertising Window start time.  
 Day 11 (7:00 PM) Day 11 (8:00 PM)

\* Event, Advertising and Preview Windows of different events on the same service may not overlap. However, the Advertising Window of one event may open while the previous event is still in progress.

T10094

## Barkers

A barker is often associated with a specific window. PPV uses three kinds of barkers. These barker types are as follows:

- **Purchase Prompt barker:** This barker prompts subscribers to buy an event when the subscriber performs one of the following actions:
  - Sets the VCR timer to record an event that has not yet occurred
  - Uses a reminder timer to notify the subscriber of an event to view in the future

Subscribers can dismiss this barker by pressing the C key on the remote control. This barker appears during the Marketing window.

- **Purchase barker:** This barker advertises the next event available for purchase. This barker appears until the subscriber buys the event, selects a different channel, or views the Advertising window.
- **Preview barker:** This barker is similar to the Purchase barker. In addition to

displaying information about the event, the Preview barker also displays a portion of the event as part of the advertisement.

**Note:** The Purchase Prompt barker and the Purchase barker appear for both RPPV and IPPV events. The Preview barker appears only for IPPV events.

## PPV Advertising Window Defaults

By default, the advertising window starts 15 minutes before an event starts and ends 45 minutes after an event starts. These values are called the *start offset* and the *end offset*. We suggest that you adjust these values if you frequently have events that are less than 60 minutes long.

Before you adjust these offsets, you must identify the length of the shortest event that you will advertise. The length of your shortest event is your minimum event interval. Use the minimum event interval and the following guidelines to determine the new default values for your offsets:

- The total offset time (start offset plus end offset) must not exceed your minimum event interval. For example, if your shortest event is 30 minutes long, then the start offset plus the end offset must not exceed 30 minutes.
- For IPPV events, the purchase window cannot start before the advertising window starts.
- The advertising window must end at least 5 minutes before the end of the event.

The following table shows two examples of minimum event intervals and identifies acceptable default values for the start offset and the end offset:

Minimum Event Interval	Advertising Window Start Offset	Advertising Window End Offset
30 minutes	10 minutes	15 minutes
59 minutes	15 minutes	35 minutes

## Modifying Default Values for PPV Advertising Windows

After you determine the default offset values for the Advertising Window, follow these steps to adjust those values:

- 1 Open an xterm window on the Application Server.
- 2 Type `cd /export/home/dnccs` and press **Enter**. The `/export/home/dnccs` directory is now the working directory.
- 3 Type `vi .profile` and press **Enter**. The vi editor opens the `.profile` file for editing.
 

**Note:** Be sure to type a period (.) before the word "profile."
- 4 Use the arrow keys to move to the bottom of the file.
- 5 Type `o`. A new line appears at the end of the file.

- 6 Type the following lines at the end of the file and press **Enter** after each line.

```
export PPV_ADV_WIND_START_INTVL=[number of seconds for new  
default start offset]
```

```
export PPV_ADV_WIND_END_INTVL=[number of seconds for new default  
end offset]
```

Examples:

```
PPV_ADV_WIND_START_INTVL=600
```

```
PPV_ADV_WIND_END_INTVL=900
```

- 7 Press **Esc**.
- 8 Type **:wq** and press **Enter**. The vi editor saves and closes the .profile file.
- 9 On the Application Server, you must stop and restart the PPV processes to activate these new values. See *Stopping and Restarting a Server Process* (on page 68) for more information.

## Define PPV Events

This section describes how to define the following types of events as defined by the billing system:

- **RPPV event:** Subscribers can purchase an RPPV event by placing a telephone call. A cable service representative (or an automated service) may order the event for the subscriber.
- **IPPV event:** Subscribers can purchase an IPPV event by using the remote control keys to purchase the event.

**Note:** After you define an event, you should use a DHCT in the headend to confirm that the event is available for ordering. By doing so, you can verify that the PPV service and the PPV event were defined correctly.

## Generating PPV Events Automatically

Typically, the billing system defines PPV events automatically. However, a solid understanding of how the billing system defines PPV events makes it easier for you to correct any errors that may occur.

Whether the billing system defines an event automatically, or you define one manually using the Application Server, either action generates an ECM (Entitlement Control Message). An ECM associates a package with the event and assigns an EID (Event ID) to the package. (Packages collect program segments into offerings that are meaningful to the subscriber and hold potential profitability for the MSO.)

**Note:** If you are generating IPPV events for a test lab, you can use the `genPpvFromIpg` utility to create PPV events using existing IPG data. The utility works by reformatting existing IPG data in the database into PPV data. For details, refer to *Application Server Utilities* (part number 749639).

**Important:** This utility is designed for use in test labs only. Do not run this utility on a live system.

The billing system automatically generates PPV events as follows:

- 1 The billing system sends the event definition to the Application Server.
- 2 The Application Server processes the definition and sends it to the DNCS for packaging.
- 3 Using the definition, the DNCS issues an ECM for the event. As part of issuing the ECM, the DNCS creates a package for the event and assigns the package an EID.
- 4 The DNCS transmits the ECM to a router, and the router forwards the ECM to the appropriate program QAM modulator.

## Generating IPPV Events Manually

Setting up an IPPV event is similar to setting up an RPPV event. However, to set up an IPPV event you must present a method for subscribers to purchase the event on their own. The following procedure provides instructions to set up an IPPV event manually.

**Note:** If you are generating IPPV events for a test lab, you can use the `genPpvFromIpg` utility to create PPV events using existing IPG data. The utility works by reformatting existing IPG data in the database into PPV data. For details, refer to *Application Server Utilities* (part number 749639). However, this utility is designed for use in test labs only. Do not run this utility on a live system.

Perform the following steps to create an IPPV event.

- 1 On the DNCS Administrative Console, select the **Server Applications** tab.
- 2 Click **PPV Event**. The PPV Event List window opens.

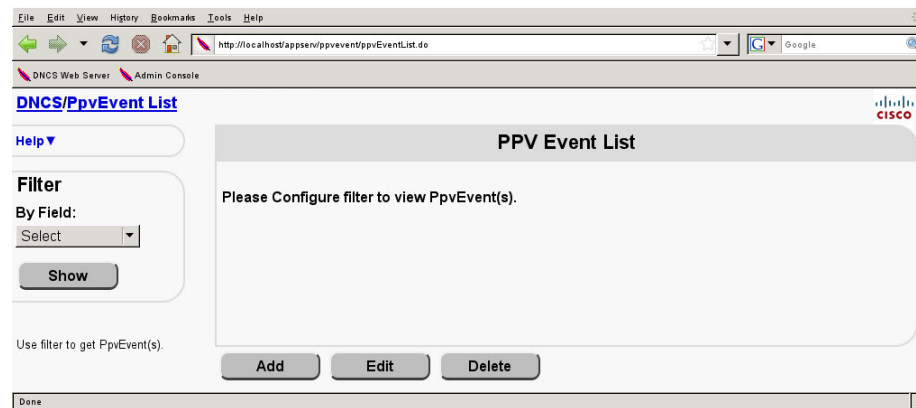

- 3 Click **Add** to view the Add PPV Event window. The window has two tabs that allow the user to access different data entry fields: the Package Info and Event Info tabs. Start by entering information into the Package Info tab to define the package that contains the event.

- 4 Select the **Package Info** tab.
- 5 In the top section of the tab, type the following information into their respective fields:
  - **Package Name:** A name for the package
  - **Start Date:** The date when the package starts in MM/DD/YY format
  - **Start Time:** The time when the package starts in HH:MM:SS format. Select AM or PM
  - **Length:** The length of the package in days, hours, and minutes
- 6 Select the **Impulse Pay Per View** option. The Preview, Buy Window, and Purchase Mode tabs become active.
- 7 Complete the fields on these tabs with data that defines how the windows function. Follow the rules of window relationships as outlined in *Understand Windows and Barkers* (on page 45). Otherwise, the Application Server applies the defaults to the data in these fields when you save it.

**Notes:**

- You can also set up a dual RPPV/IPPV event by selecting both Reservation Pay Per View and Impulse Pay Per View options. Then, complete the fields in the Set Up PPV Event window for both types of events.
- When you set up a dual RPPV/IPPV event, DHCTs that can purchase IPPV events will display IPPV advertisements for the event, and subscribers will be able to use their remote controls to purchase the event. DHCTs that can purchase RPPV events will display a telephone number that prompts subscribers to phone in an order for an event.

**8 Select the Event Info tab.**

The screenshot shows a web browser window displaying the 'Add PPV Event' form. The form is divided into several sections:

- Event Info:** Contains a 'Service Name' dropdown menu with 'asd' selected, a 'Retail Price' text input field, and an 'English Event Title' text input field.
- Reservation PPV Event Order Phone Info:** Contains a 'Phone Number' text input field, a 'Start Date' dropdown menu with '09/16/2010' selected, and a 'Start Time' dropdown menu with 'HH:MM:SS' and 'AM' selected.
- Advertising and Marketing Windows:** Includes checkboxes for 'Specify Advertising Window' and 'Specify Marketing Window'. Below these is a sub-section for 'Advertising Window' (selected) with 'Start Date' (09/16/2010), 'Start Time' (HH:MM:SS AM), and 'Duration' (0 hours, 0 minutes) fields.

At the bottom of the form are 'Save' and 'Cancel' buttons.

**9 At the top type the following information in the fields:**

- **Service Name:** Select the appropriate PPV service that advertises this event
- **Retail Price:** The price of the event. If entered, the price appears on the subscribers IPG
- **English Event Title:** The title of the event. The title appears during the Advertising, Purchase, and Preview windows. Event titles are available in multiple languages if you have set up the languages on the DNCS

- 10 If you choose the **Specify Advertising Window** and **Specify Marketing Window** options, enter the data (Start Date, Start Time and Duration) defining how these windows function in their fields on the respective tabs. Otherwise, the Application Server applies the defaults to the data in these fields when save it.
- 11 When you finish entering all the data, click **Save** to save your changes, then click **Cancel** to close the window.
- 12 Check the PPV Service List to ensure verify that source you created is on the list and that the source information is correct.

## Generating RPPV Events Manually

Perform the following steps to create an RPPV event.

- 1 On the DNCS Administrative Console, select the **Server Applications** tab.
- 2 Click **PPV Event**. The PPV Event List window opens.

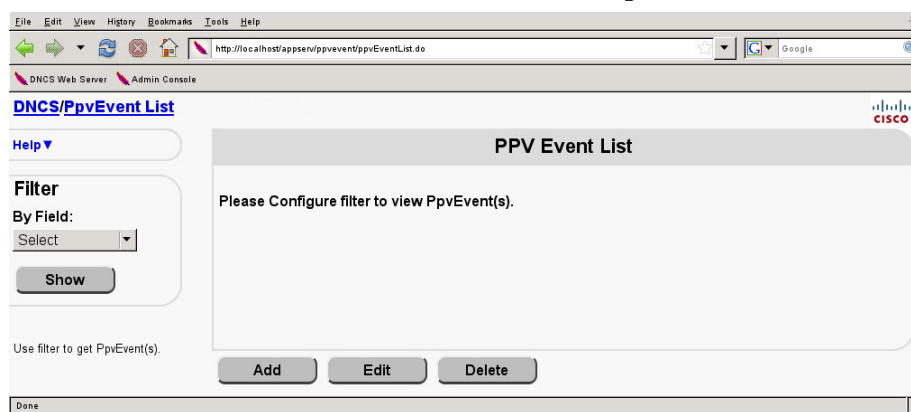

- Click **Add** to view the Add PPV Event window. The window has two tabs that allow the user to access different data entry fields: the Package Info and Event Info tabs. Start by entering information into the Package Info tab to define the package that contains the event.

- Select the **Package Info** tab.
- In the top section of the tab, type the following information into their respective fields:
  - **Package Name:** A name for the package
  - **Start Date:** The date when the package starts in MM/DD/YY format
  - **Start Time:** The time when the package starts in HH:MM:SS format. Select AM or PM
  - **Length:** The length of the package in days, hours, and minutes
- Select the **Reservation Pay Per View** option.
- If you want subscribers to have the right to copy the event, select the **Allowed** option.

8 Select the **Event Info** tab.

9 In the top section of the tab, type the following information into their respective fields:

- **Service Name:** Click the down arrow and select the appropriate PPV service that advertises this event
- **Retail Price:** The price of the event. If entered, the price appears on the subscriber's IPG. Type this price exactly as it should appear on the IPG, including dollar sign and decimal, if appropriate
- **English Event Title:** The title of the event. The title appears during the Advertising, Purchase, and Preview windows
- **Phone Number:** The telephone number subscribers can call to order the event. Type this number exactly as it should appear on the IPG, including parentheses and dashes, if appropriate
- **Start Date:** The date on which the event is to begin. Type this date in the format MMDDYY. Do not type slashes in this date. This date must be in the future
- **Start Time:** The time at which the event is to begin. Type this time in the format HHMM. Do not type colons in this time. Must be at least 15 minutes in the future. Select AM or PM

- 10 If you choose the **Specify Advertising Window** and **Specify Marketing Window** options, then enter the data defining how these windows function in their fields on the respective tabs. Otherwise, the Application Server applies the defaults to the data in these fields when you save the changes.  
**Note:** These windows let you specify the start date, start time, and duration for the advertising window or marketing window.
- 11 Click **Save** when you finish entering all the data.  
**Note:** The Set Up PPV Event window disappears and the Application Server saves your changes.
- 12 Verify that the source you created now appears in the **PPV Service List** window and that the source information is correct.
- 13 From the DNCS Administrative Console, click **Package** on the DNCS System Provisioning tab to access the Package List window.

The screenshot shows the 'Package List' window in the DNCS Administrative Console. The window title is 'DNCS/Package List' and it features the Cisco logo in the top right corner. On the left side, there is a 'Filter' section with a 'By Field:' dropdown set to 'Package Name' and a 'By Value:' text input containing 'tst'. A 'Show' button is located below the filter. The main area displays a table with the following data:

<input type="checkbox"/>	<a href="#">Package Name</a>	<a href="#">Package Description</a>
<input type="checkbox"/>	tstmay12again	Testing May 12 afternoon
<input type="checkbox"/>	tstMotifStage1	
<input type="checkbox"/>	tstMotifStage2	
<input type="checkbox"/>	tstStage1	
<input type="checkbox"/>	tstStaging1	Testing if can save a staging package
<input type="checkbox"/>	tstStaging2	tsting saving Default Staging again
<input type="checkbox"/>	tstStaging3	Testing to see if get to rpcUIServer
<input type="checkbox"/>	tstStaging4	tstlog
<input type="checkbox"/>	UtilityPackageTest1	

Below the table are three buttons: 'Add', 'Edit', and 'Delete'. The top of the window shows navigation controls: 'Total Row(s): 389', 'Rows per page: 10', 'Page 39 of 39', and a search box.

- 14 Use the **Filter** fields to view a list of packages, either by Package Name or by Package Type.
- 15 Verify that a segment exists for the package that contains the RPPV segment.

- 16 In the Package List window, highlight the package and click **Provision**. The Package Provisioning window opens and displays the segment for the RPPV event you just created.



## Modifying a PPV Event

Use the following steps to modify a PPV service.

- 1 On the PPV Event List window, select the event you want to modify.
- 2 Click **Edit** to view the Modify PPV Event window with completed fields.
- 3 Make necessary changes in the fields, and then click **Save**.

## Deleting a PPV Event

Use the following steps to delete a PPV event.

- 1 Select the event you want to delete in the PPV Event list window.
- 2 Click **Delete**. A Question window opens, prompting you to confirm that you want to delete the current item.
- 3 Click **Yes** to confirm.

# 6

## Setting Up the Interactive Program Guide

The IPG is an application that DHCTs use to display program information, such as the program name, start and end times, description, and rating. When you set up the IPG, the DNCS populates the IPG with data such as program listings and program descriptions. The Application Server provides other information on the IPG such as instructional text (for example, the words Browse By and Choose Date) and other General Settings menus. If you do not set up the IPG correctly, the IPG appears with no program information, even when a subscriber selects the Guide button.

IPG data is linked to a specific program service using the IPG service provider's designation and the SAM service ID number. This link ensures that information and program descriptions are matched to the correct services.

This chapter provides procedures for setting up the IPG.

**Important:** Enabling DVS support on the Application Server allows you to offer your subscribers audio streams designed for the visually impaired. Once enabled, DVS will cause new IPG options to be displayed in Quick Settings and General Settings. For details about enabling DVS, see *Enable DVS Support* (on page 29).

### Notes:

- Obtaining and providing audio streams is the responsibility of the operator.
- Audio streams must be encoded within an MPEG program.
- It is recommended that this option not be enabled unless you are familiar with DVS and your content is encoded with DVS audio streams.

## In This Chapter

- Before You Begin..... 61
- Set Up the IPG ..... 64
- Add IPG Data Manually ..... 74
- Edit Existing IPG Data ..... 77
- Add Your Company's Logo to the Main IPG Screen..... 79
- Configurations That Enhance Your Subscribers' Experience ..... 83
- IPG Memory Usage Settings ..... 84
- Adjust How DHCTs Use IPG Memory..... 90
- Selecting the Number of Days of IPG Data to Produce..... 95
- Graying Out Unauthorized Channels in IPG ..... 96
- Configure the ISDP for EPG Search ..... 97

## Before You Begin

The IPG is an application that DHCTs use to present program information, including the program name, start and end times, description, and rating.

- Subscribers can use the IPG to view and purchase programs.
- Subscribers can access the IPG by pressing the Guide button on the DHCT remote control, and then scrolling through the list. When you press the Guide button, the picture on the current channel reduces to fit one-quarter of the television screen and appears on the upper right corner of the screen, as shown in the following example.





### Areas of the IPG

The IPG can be divided into three areas:

- **Top Left Quarter:** The top left corner includes the channel number (304), SAM short description (FLIX), and the channel logo of the highlighted program. This section contains detailed information about the current channel, including the full channel name, the start and end time of the current program, and a description of the program. The description may appear truncated due to screen limitations, but you can always access the full program description by pressing the **Info** button on the remote control.

**Note:** Space in this section is also available for an optional Multiple System Operator (MSO) logo. For instructions on positioning your logo, see Positioning Your Logo on the Main Screen of the IPG.

- **Top Right Quarter:** The top right corner shows the quarter-screen picture, channel number, date, and time.
- **Bottom Half:** The bottom half of the screen shows the listings for several channels arranged in chronological order. The strip along the bottom of the screen identifies the date for these listings and indicates the way these listings

are arranged ("by time" in this example). Pressing the  button lets you browse these listings alphabetically by title or by theme, and pressing the  button lets you view listings for a different date. In addition, if you press the Info button, this section of the screen displays more detailed information about the highlighted program.

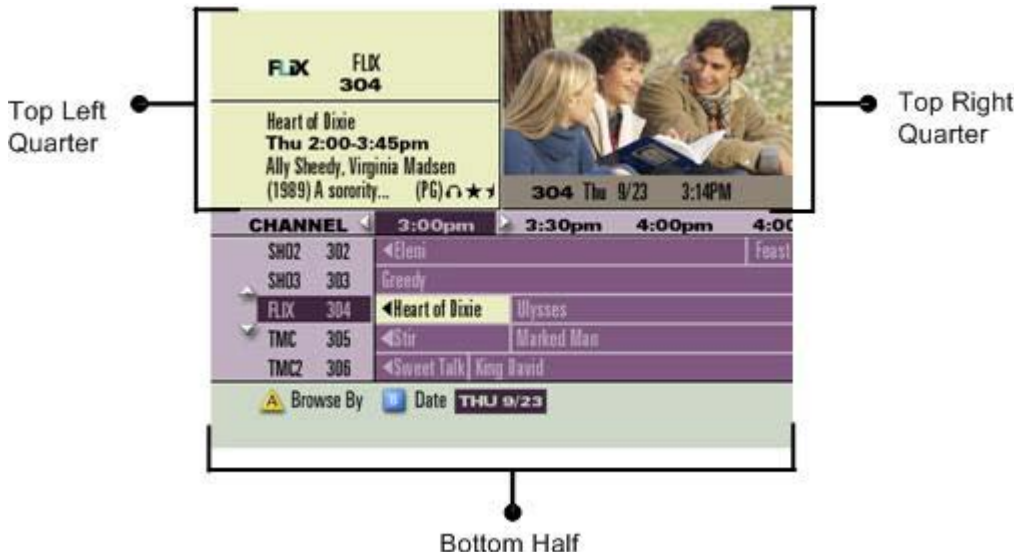

## Collecting the IPG Data

In order to provide IPG data you must set up IPG collectors and IPG servers, and you must map IPG data to SAM services. The IPG collectors receive IPG data through the data provider's File Transfer Protocol (FTP) website. This data is stored in a provider-neutral format in the Application Server database.

For each IPG collector, there must be an IPG server. The IPG servers pull data from the DNCS database and create files on the Broadcast File System (BFS). The DHCTs can then download data as needed.

The following table lists and describes the information you must have in order to set up each IPG collector.

IPG Data Required	Description
The IPG service provider	Specifies the format in which to provide data to the subscriber. We support three formats: TV Data, On TV, and SA COMP (SA-Compatible) formats
Host Name	Specifies the FTP site from which to retrieve the data. The host name can be a standard Web name, such as ftp.tvdata.com if the Application Server uses Domain Name Service (DNS), or a raw IP address such as 204.97.140.250
User Name	Specifies your user name. The IPG data provider will give you this name.

<b>IPG Data Required</b>	<b>Description</b>
Password	Specifies your password. The IPG data provider will give you this password
Pickup Directory or Data file location	Specifies the directory from which to retrieve data files. The IPG data provider will give you this directory.
File Template	Specifies the naming convention of the file to be retrieved
Collection Time	Specifies the time the IPG collector will collect new data from the data provider
Service Names	Specifies the service names used by the content provider.
Logo File	If using a logo, the logo file must be present on the DNCS. For more information, see <i>Adding a File Containing Your Company's Logo to the BFS</i> (on page 80).

## Set Up the IPG

The process for setting up IPG services includes the following tasks:

- Selecting languages that subscribers can choose to display IPG data
- Setting up the IPG servers for each language
- Setting up IPG collectors for each language
- Setting up the IPG services

This section also includes procedures to modify and delete IPG Service names.

If you provide IPG data in foreign languages, you must set up the languages for the IPG data before you set up the IPG. When you first install your system, the IPG is available in at least one language. For the DNCS to allow you to create additional IPG servers and collectors, you must first select the languages that you offer.

SR 2.5 and later, SR 5.0 and later, and SR 4.0 and later provide support for IPG data in English, French, Spanish, and Japanese. For detailed instructions on setting up support for foreign languages, see *Set Up Supported Languages* (on page 20).

## Setting Up An IPG Server

The IPG server is not a physical server. Instead, it is a process named ipgServer that resides on the Application Server. The IPG server uses the IPG information in the database to create IPG data files. The DBDS uses these IPG data files to display program information in the IPG.

Use the following steps to set up IPG servers.

- 1 On the Server Applications tab, click **IPG**. The IPG Server List window opens, similar to the following example.



- 2 Click **Add Server**. If you have enabled any language that does not yet have an IPG server, the Add IPG Server window opens, similar to the following example.

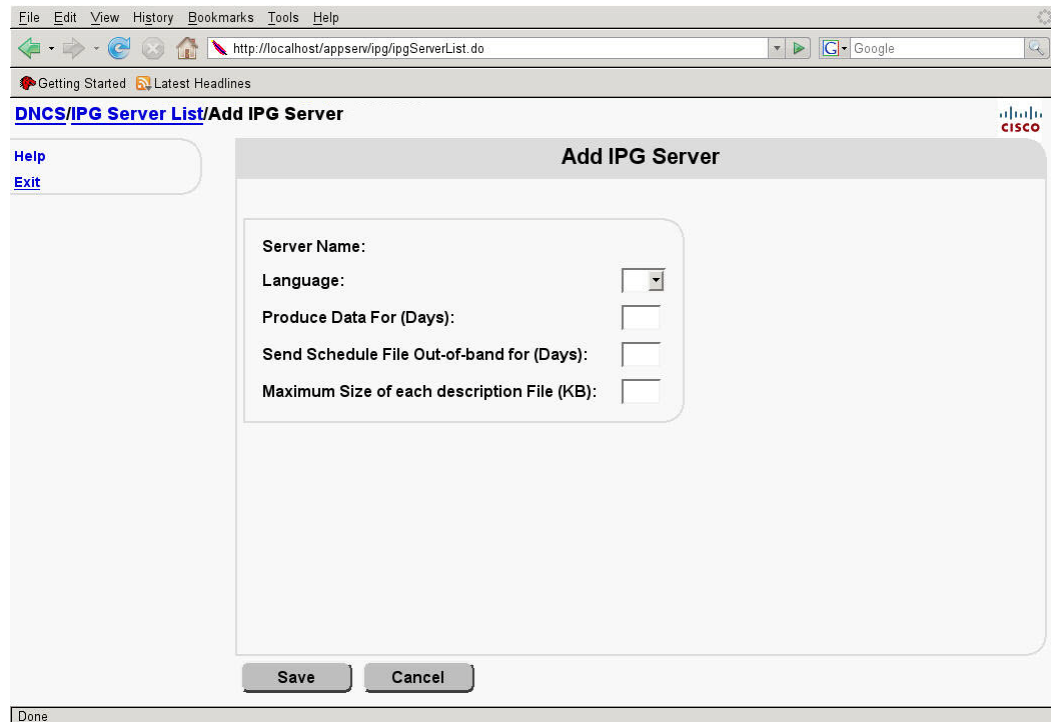

**Note:** If all languages already have IPG servers, the following message appears in the bottom pane of the IPG Server List window: No Languages found.

- 3 Click the **Language** arrow and select the language from the list.

**Note:** The Supported Languages that you selected earlier appear in the list.

- 4 Type the appropriate information for the following fields:

- Type **7** in the *Produce Data for* field.
- Type **2** in the *Send Schedule File Out-of-band for* field.



**CAUTION:**

The BFS requires a lot of bandwidth to send IPG data out of band. If you schedule out-of-band data for more than 2 days, you may cause the BFS Server to function incorrectly and disrupt service to subscribers.

- 5 Click **Save** to save your changes, then click **Cancel** to close the window.

## Editing IPG Servers

Use the following steps to edit an existing IPG server.

- 1 On the Server Applications tab, click **IPG**. The IPG Server List window opens.



- 2 Select the IPG server whose settings you want to edit, and then click **Edit**. A message reminds you to stop and restart the ipgServer process before your changes will take effect.
- 3 Click **OK**. The Information message closes and the Edit IPG Server window opens for the server that you selected.

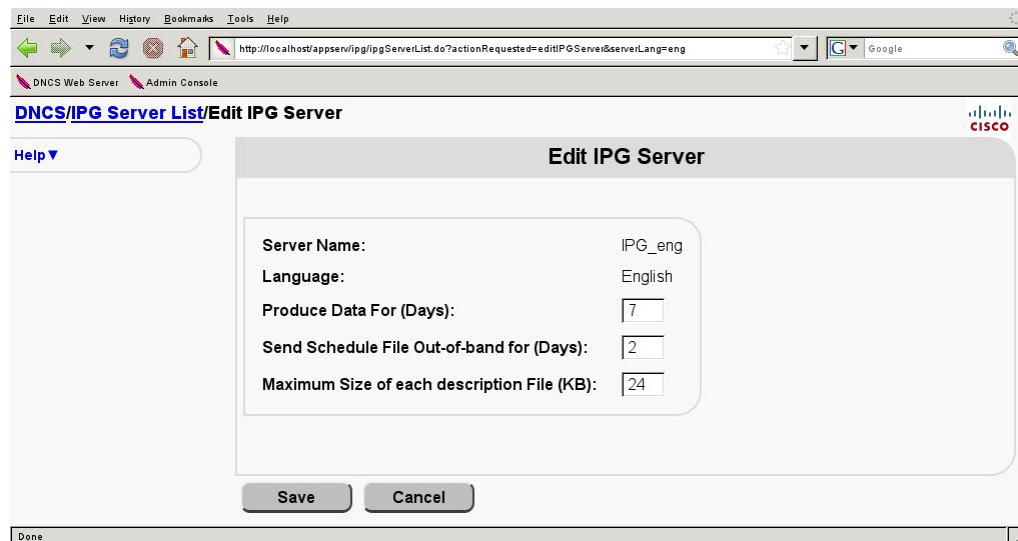

- 4 Edit either of the following settings by typing the appropriate information for the following fields:
  - Produce Data for(Days). A typical choice is 7.
  - Send Schedule File Out-of-band for (Days). A typical choice is 2.

 **CAUTION:**  
 The BFS requires a lot of bandwidth to send IPG data out of band. If you schedule out-of-band data for more than 2 days, you may cause the BFS Server to function incorrectly and disrupt service to subscribers.

- 5 Click **Save** to save your changes, then click **Cancel** to close the window.

- 6 Now that you have edited the settings for this server, stop and restart the ipgServer process in order for the changes to take effect. For assistance, go to *Stopping and Restarting a Server Process* (on page 68).

## Stopping and Restarting a Server Process

If you changed the settings of an existing server process, you must stop and restart the server process in order for your changes to take effect.

Use the following steps to stop and restart the server process.

- 1 Open an xterm window on the Application Server and log in as dncs user.
- 2 Type **appControl**, and press **Enter**. The Applications Control window opens, similar to the following example.

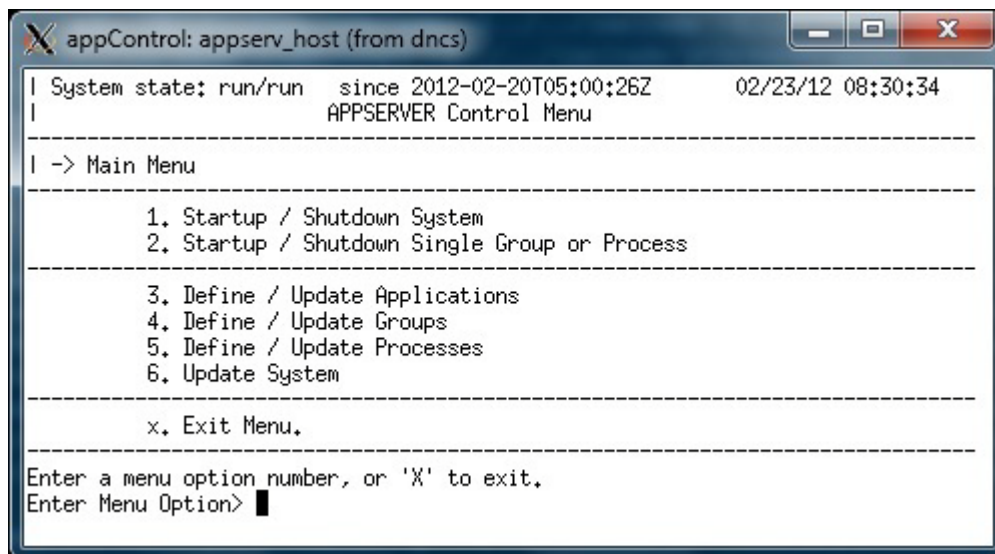

```

X appControl: appserv_host (from dncs)
| System state: run/run   since 2012-02-20T05:00:26Z   02/23/12 08:30:34
|
| APPSERVER Control Menu
|-----
| -> Main Menu
|-----
|
| 1. Startup / Shutdown System
| 2. Startup / Shutdown Single Group or Process
|-----
|
| 3. Define / Update Applications
| 4. Define / Update Groups
| 5. Define / Update Processes
| 6. Update System
|-----
|
| x. Exit Menu.
|-----
|
| Enter a menu option number, or 'X' to exit.
| Enter Menu Option> █

```

- 3 Type **2** (for Startup/Shutdown Single Group or Process), and press **Enter**. The Applications Control window displays a numbered list of servers and processes, similar to the following example.

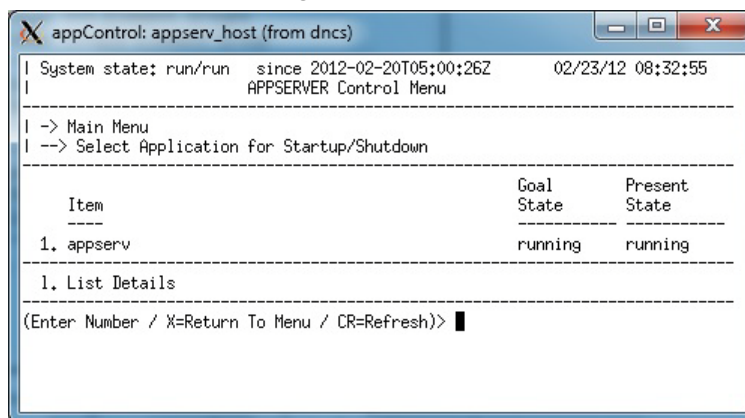

```

X appControl: appserv_host (from dncs)
| System state: run/run   since 2012-02-20T05:00:26Z   02/23/12 08:32:55
|
| APPSERVER Control Menu
|-----
| -> Main Menu
| --> Select Application for Startup/Shutdown
|-----
|
| Item                               Goal State   Present State
|-----
| 1. appserv                          running     running
|-----
|
| 1. List Details
|-----
|
| (Enter Number / X=Return To Menu / CR=Refresh)> █

```

- 4 Type the number associated with the server process, and press **Enter**. The Applications Control window prompts you to enter a target status for the selected element group, similar to the following example.

```

appControl: appserv_host (from dnscs)
-----
| -> Main Menu
| --> Select Application for Startup/Shutdown
| ----> Startup/Shutdown Application
-----
Enter new goal state for Application appserv(1), in the range 1-4.

    1. stopped
    2. running
    3. enabled
    4. disabled

-----
    e. Display Groups
    1. List Details
-----
goalState: running presentState: running
(#{e/l/x}) goalState-----?> █

```

- 5 Type **e** (to display groups) and press **Enter**.

```

appControl: appserv_host (from dnscs)
-----
| --> Select Application for Startup/Shutdown
| ----> Startup/Shutdown Application
| ----> Select Group from Application
-----

```

Item	Goal State	Present State
1. DHCT Config Server	running	running
2. IPG Server	running	running
3. Virtual Channel Serv	running	running
4. PPV Processes	running	running
5. applogMgr	running	running
6. appUIServer	running	running

```

-----
    1. List Details
-----
(Enter Number / X=Return To Menu / CR=Refresh)> █

```

- 6 Type **4** to select the PPV processes and press **Enter**.

```

appControl: appserv_host (from dnscs)
-----
| --> Select Application for Startup/Shutdown
| ----> Startup/Shutdown Application
| ----> Select Group from Application
| ----> Set Status for Group
-----
Enter new goal state for group PPV Processes(4), in the range 1-4.

    1. stopped
    2. running
    3. enabled
    4. disabled

-----
    e. Display Process Entries
    1. List Details
-----
goalState: running presentState: running
(#{e/l/x}) goalState-----?> █

```

- 7 Type **1** (for stopped) and press **Enter**. The Applications Control window refreshes.

**Note:** The Applications Control window refreshes in real time, or you can press Enter to force a refresh.

- 8 Wait until Present State of the server process indicates stopped.

- 9 To restart the group, type **4** to select the PPV processes and press **Enter**.

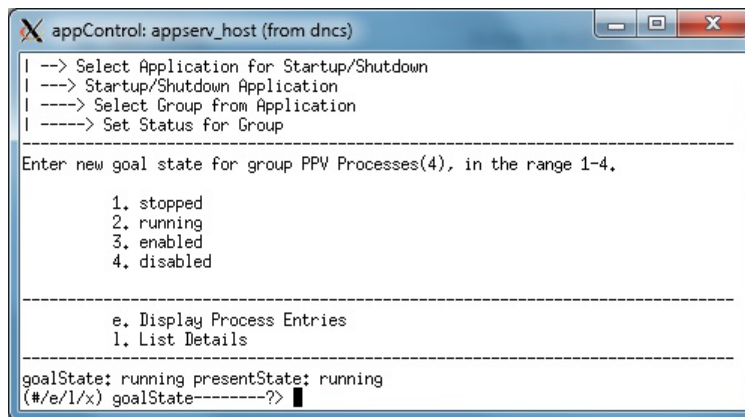

- 10 Type **2** (for running) and press **Enter**. The Applications Control window refreshes.

**Note:** The Applications Control window refreshes in real time, or you can press Enter to force an immediate refresh.

- 11 Wait until Present State of the server process indicates running.
- 12 Follow the on-screen instructions to return to the main menu and exit from the appControl utility.

## Setting Up the IPG Collector

The IPG collector is a process that resides on the Application Server. The IPG collector automatically runs once a day to retrieve IPG data from the IPG data provider.

Use the following steps to set up IPG collectors.

- 1 On the IPG Server List window, highlight the desired language server and click **Add IPG Collector**. The IPG Collector window opens, similar to the following example.

- 2 Complete all the fields by typing the required information, and click **Save**.  
**Important:** Leave the Max Long Description Length set to its default value of 240.

**Notes:**

- The video service provider and the IPG data provider supply all the information for these fields, for example, the user name and password, file template, and retrieval directory. The server updates data sent to DHCTs at midnight. Therefore, the collection time should be set as late as possible, but early enough for collection to finish before midnight.
  - When you set up the IPG collector, it is a good idea to ping the IPG provider's site to make sure that you can connect to the provider's site.
  - Occasionally, a ping may not work. In this instance, use the command **ftp <site IP address or site name>** to verify that the site can communicate with the IPG data provider.
- 3 On the Password Prompt window that opens, retype the password, and then click **Continue**. The system confirms the password, and then the IPG Server List window opens again.

## Setting Up IPG Services

After setting up the languages, IPG server, and IPG collector, you are ready to set up the IPG Service. Perform the following steps to set up IPG Services.

**Note:** To set up IPG Services, you will use the service name list from your content provider and map the service names to SAM Service IDs.

- 1 On the IPG Server List window, click **IPG Services**. The IPG Services List window opens.
- 2 In the **Filter By Field** area, select **All** and click **Show** to view the list of IPG services.

The screenshot shows the 'IPG Services List' interface. The table contains the following data:

<input type="checkbox"/>	Service Name	Service ID
<input type="checkbox"/>	TBS	187
<input type="checkbox"/>	WUPA	113
<input type="checkbox"/>	WSB	108
<input type="checkbox"/>	HBOE	233
<input type="checkbox"/>	SHOE	241
<input type="checkbox"/>	STZWE	230
<input type="checkbox"/>	TVLAN	224

- 3 Click **Add** to view the Create IPG Service window.

The screenshot shows the 'Create IPG Service' interface with the following form fields:

- IPG Provider Service Name:
- SAM Service ID:

- 4 Type the IPG Provider Service Name and the SAM Service ID.

**Notes:**

- The SAM Service ID is the ID number assigned by the DNCS when the service was registered with the SAM. For more information on registering services with the SAM, refer to the *Digital Network Control System Online Help* for your system release.
  - Service IDs for all services are shown in the SAM Services List window.
  - For each PPV service that you set up, you must enter both the PPV service and the Event Use service in the IPG service list. If you do not enter both services, event information will be missing from the IPG grid (which requires the PPV service ID) or the PPV purchase barker (which requires the Event Use service ID).
- 5 Click **Save** to save your changes, then click **Cancel** to close the window.

## Modifying an IPG Service Name

Perform the following steps to modify an IPG service name.

**Important:** The IPG service names should match the names that your data provider uses in the IPG collector file.

- 1 Highlight the desired IPG server in the IPG Server List window.
- 2 Click **IPG Services** to view the IPG Service List window.
- 3 On the IPG Service List window, highlight the row of the desired IPG service.
- 4 Make changes to the IPG Provider Service Name, and click **Save**.

**Note:** You can only change the IPG Provider service name. You cannot change the SAM service ID.

## Deleting an IPG Service Name

Perform the following steps to delete an IPG service name.

- 1 Select the IPG server you want to delete in the IPG Server List window.
- 2 Click **IPG Services**.
- 3 On the IPG Service List window, highlight the row of the desired IPG service.
- 4 Click **Delete**. A Question window opens, prompting you to confirm that you want to delete the current item.
- 5 Click **Yes** to confirm that you want to delete the IPG service name.

## Add IPG Data Manually

Usually, your site receives program information from an IPG data provider and passes that data to the IPG without altering the information at all. However, in some cases, no data is provided. This is typically the case for local access channels. To provide subscribers with IPG data in these instances, add the IPG data manually by following the directions explained in this section.

### Overview of Adding IPG Data Manually

To provide subscribers with IPG data when no data has been provided by the IPG data provider, perform the following steps to manually add IPG data to the service.

- 1 Create an IPG service for the missing data.  
**Note:** For assistance, see *Creating an IPG Service from an Existing SAM Service* (on page 74).
- 2 Map the service to an appropriate SAM service.  
**Note:** For assistance, see *Creating an IPG Service from an Existing SAM Service* (on page 74).
- 3 Add IPG data for the service you created.  
**Note:** For assistance, see *Manually Adding Data to an IPG Service* (on page 75).

### Creating an IPG Service from an Existing SAM Service

Complete these steps to create an IPG service so that you can manually add data to the service.

- 1 From the DNCS Administrative Console, click the **Server Applications** tab.
- 2 Click **IPG**. The IPG Server List window opens.
- 3 Click **IPG Services**. The IPG Services List window opens.

- Click **Add**. The Create IPG Service window opens, similar to the following example.

The screenshot shows a web browser window with the following details:

- Address bar: `http://localhost:appserv/ipg/ipgServerList.do`
- Page Title: **DNCS/IPG Server List/IPG Services List/Create IPG Service**
- Page Content:
  - Header: **Create IPG Service**
  - Form Fields:
    - IPG Provider Service Name:
    - SAM Service ID:
  - Buttons: **Save** and **Cancel**

- Complete these steps to enter data in the Create IPG Service window:
  - In the IPG Provider Service Name field, enter a name for the new service that is unique and does not match any of the names provided by your IPG service provider. For example, you might use "localdata1" to indicate that this is data for a local access channel.
 

**Note:** You can enter up to 12 characters in this field.
  - In the SAM Service ID field, enter the number of the SAM service that you want to map to this IPG data.
- Click **Save** to save your change. The IPG Services List window indicates "Save Complete" and adds the service you created to the window.
- Go to *Manually Adding Data to an IPG Service* (on page 75).

## Manually Adding Data to an IPG Service

Complete these steps to manually add new IPG data to the IPG service you have just created.

- From the IPG Server List window, select the server to which you want to add IPG data.
- Click **File** and select **Program Data**. The Program Data List window opens.
- Click the box for **Show only mapped services** and then click **Get Data from Database**. A message appears at the bottom of the Program Data List window letting you know that the DNCS is loading the data you selected.
 

**Note:** It may take a few minutes for the program data to load.
- When a message appears at the bottom of the window to let you know that all of the data has loaded, click **File** and select **New**. The Set Up Program Data window opens.

- 5 Enter data for the service by completing the fields of the Descriptions and Features tabs.  
**Note:** When selecting the Service Name, make certain to select the service that you created earlier in Creating an IPG Service.
- 6 Click **Save**. A Question window opens to let you know that overlapping program data will be overwritten.
- 7 Click **Yes**. A message appears at the bottom of the Set Up Program Data window letting you know that the program data has been saved.
- 8 Click **Cancel** to close the Set Up Program Data window. The Program Data List window is now visible.
- 9 On the Program Data List window, click **View** and select **Refresh**. A message appears at the bottom of the Program Data List window letting you know that the program data is being loaded.
- 10 When the program data has loaded, the IPG data that you added appears in the Program Data List window.
- 11 Click **File** and Select **Close**. A Question window opens and prompts you to select whether or not you want to send an update to the server.
- 12 Click **Yes**. The Question window and the Program Data List window both close.
- 13 To close the the IPG Server List window, click **File** and select **Close**.

## Edit Existing IPG Data

Complete these steps to edit existing IPG data.

- 1 On the Server Applications tab, click **IPG**. The IPG Server List window opens.
- 2 Select the IPG server that contains the data you want to modify.
- 3 Click the **File** menu and select **Program Data**. The Program Data List window opens.
- 4 Follow these instructions to select the data you want to display.
  - To select program data in a specific language, click the **Language** arrow (▲) and select the language you want to display from the list that opens.
  - To select program data for a particular date, click the **Reverse** (▲) or **Advance** (▼) arrow until the date you want appears.
- 5 Click **Get Data From Database**. A message appears at the bottom of the Program Data List window letting you know that the DNCS is loading the data you selected. It may take a few minutes for the program data to load.
 

**Note:** To display only the services that have been placed on a channel map, click to enable **Show only mapped services**.
- 6 Use the scroll bars along the bottom and right sides of the window to locate the program whose data you want to edit. Then, select the program.
- 7 Click the **File** menu and select **Open**. The Set Up Program Data window opens and displays existing data for the program you selected.
- 8 Change the existing data in the Descriptions tab.
 

**Note:** Only the following fields can be changed:

  - Title
  - Short title
  - Description
  - Primary Theme
  - Secondary Theme
- 9 Click the **Features** tab. The Features tab moves to the forefront.
- 10 To change existing program data, select features that apply to the program or clear features that no longer apply.
 

**Important:** Not all feature tags listed can be displayed by all versions of the Application Server. For example, the High Definition feature only displays in Application Server 1.52 and later.
- 11 Click **Save**. The Set Up Program Data window closes.
- 12 To edit other program data, repeat steps 4 to 11.

- 13 After you have completed editing program data, click the **File** menu in the IPG Server List window, and select **Send**. The IPG Server sends the updated information to the IPG collector.

## Add Your Company's Logo to the Main IPG Screen

Each time subscribers tune to the IPG, remind them who provides this service by placing your company's logo on the main screen of the IPG. Adding a file containing your company's logo to the BFS causes the logo to appear on the main screen of the IPG. You can also use the MSO Logo Position option to position the logo to either the left or right of the channel number.

This section describes how to add a file containing your company's logo to the BFS and how to position the logo on the main screen of the IPG.

### Logo Positions

The following screens show an example of the logo positions.

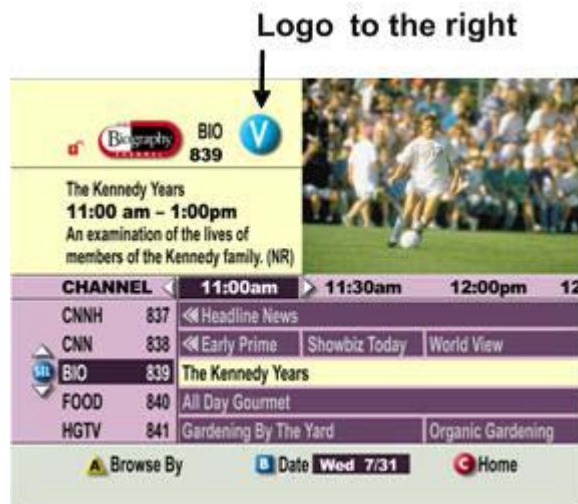
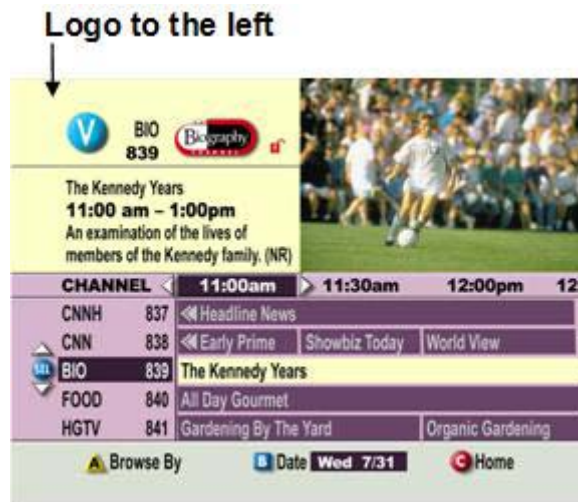

## Adding a File Containing Your Company's Logo to the BFS

To add a file containing your company's logo to the BFS, perform the following steps.

- 1 Has the video service provider's logo been placed on the OSM data carousel?
  - If **yes**, go to step 5.
  - If **no**, open an xterm window on the DNCS.
- 2 Type **cd /dvs/resapp/logos** and press **Enter**. The system makes /dvs/resapp/logos the working directory.
- 3 Copy the file containing the logo from the directory where it is currently stored to /dvs/resapp/logos.
- 4 Type **exit** and press **Enter**. The xterm window closes.
- 5 Click the **DNCS** tab on the DNCS Administrative Console window.
- 6 Click the **Home Element Provisioning** tab.
- 7 Select **OS** in the **DHCT Provisioning** area. The DHCT OS List window opens.
- 8 Is there an entry in the DHCT OS list named **msologo.rle**?
  - If **yes**, select **msologo.rle** and click **Delete** to delete it. Then go to step 9.
  - If **no**, go to step 9.
- 9 Click **Add**. The Add DHCT OS window opens.

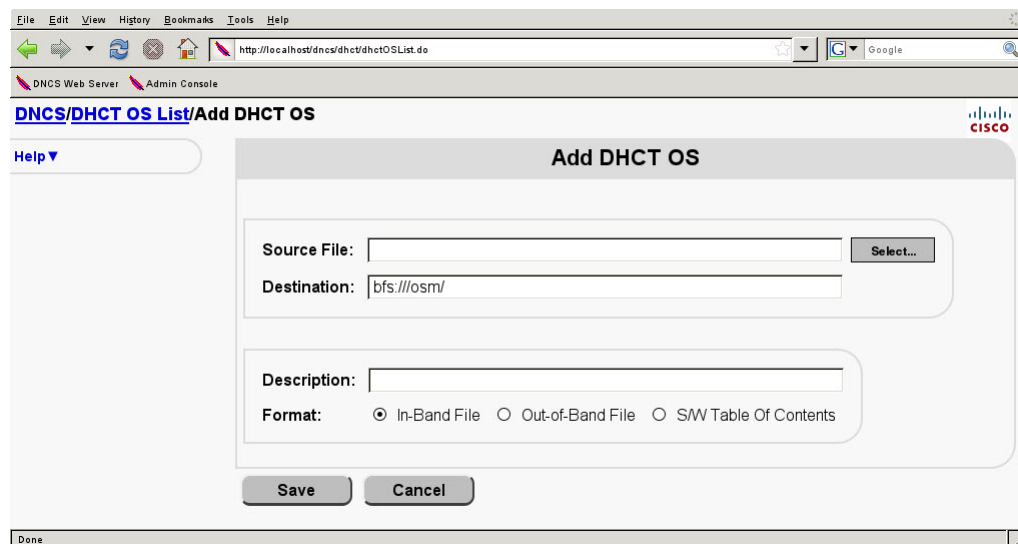

- 10 Click **Select** in the **Source File** field. A window opens to let you select your OS file.
- 11 In the Directories list on the left, click twice to select the **/dvs/resapp/logos** directory. The files contained in the /dvs/resapp/logos directory appear in the Files list on the right.
- 12 In the Files list, select the RLE file containing the logo that you want to appear in the Recorded List. The full path of the RLE file that you selected appears in the Selection field.

- 13 Click **OK**. The window closes, and the file that you selected appears in the Source File field on the Add DHCT OS window.
- 14 In the Destination field, type **bfs:///osm/msologo.rle**.
- 15 In the Description field, type **IPG Logo**.
- 16 For Format, select **Out-of-Band File**.
- 17 Click **Save** to save the logo file to the OSM data carousel. After the DVR cable box reboots, the Application Server client displays the logo in the Recorded List.

## Positioning Your Logo on the Main Screen of the IPG

To position your logo on the main screen of the Interactive Program Guide, perform the following steps.

- 1 On the DNCS Administrative Console, select the **Server Applications** tab.
- 2 Click **DHCT Config**. The DHCT Configure window opens.
- 3 Select **Global**. The Set Up Global DHCT Configuration window opens.
- 4 Select the **IPG** tab. The IPG tab appears in the forefront.

The screenshot shows the 'Set Up Global DHCT Configuration' window with the 'IPG' tab selected. The 'MSO Logo Position' option is highlighted with a red box. The window includes sections for 'Initial View', 'Options', 'Behaviour', and 'Memory Usage'.

**Initial View**  
Browse by: Time

**Options**  
 Display 'Browse by' menu  
 Highlight current program  
 Show Tuned Channel Banner  
 Show visual cue for unauthorized channels

**Behaviour**  
 IPG Scrolls: 10 minutes before the half hour  
**MSO Logo Position:**  Left  Right  
 Numeric Key Response: Exit IPG, tune to channel  
 Show button: Yes  No Icon or Label  Icon  Label Base

**Memory Usage**  
 Leave Largest Contiguous Free KB: 512  
 Additional Total Free In Excess of Largest Contiguous KB: 256  
 Use Fixed Size Grid File Data Allocations KB(0=variable): 0 (disabled)

Buttons: Save, Cancel

- 5 For the MSO Logo Position option, select either Left or Right to place your logo either to the left or to the right of the channel number on the Interactive Program Guide.

## Chapter 6 Setting Up the Interactive Program Guide

- 6 Click **Save**. The logo appears either to the left or right of the channel number in the IPG.

# Configurations That Enhance Your Subscribers' Experience

## Overview

Explorer DHCTs use a standard set of default parameters that define the way they operate and affect subscribers' experience with the Application Server.

## Creating DHCT Configurations

Explorer DHCTs use a standard set of default parameters that define the way they operate and affect subscribers' experience with the Application Server. You can create customized sets of these parameters (called DHCT configurations) and apply different DHCT configurations to all DHCTs in your network, to all DHCTs in a hub, or to a single DHCT.

For assistance configuring the Application Server, refer to *Enhancing Your Subscribers' Experience: SARA Configurable Options* (part number 4002178).

For assistance configuring DVR or DVD features, refer to *DVR Configuration Guide* (part number 4011411).

## IPG Memory Usage Settings

### Overview

This section describes IPG Memory Usage settings, which allow you to fine tune how the IPG utilizes memory. These adjustments can be made on a site basis or (for testing purposes) on a hub basis. Adjusting these settings may enable you to maximize memory usage, especially on lower-memory DHCTs such as Explorer 2000s.

Usually, your site will receive program information from an IPG data provider and pass that data to the IPG without altering the information at all. However, you may occasionally need to change the program information. This section explains how to edit existing IPG data.

**Important:**

- The editor is ideally only used to provide data on channels where the provider does not provide data.
- Editing programs for services where the content provider sends information will only be effective until the collector runs again. You must work with the data provider to avoid having outdated or incorrect data they send overwrite the edits you make.

## IPG Memory Usage Settings

You'll find the settings for IPG Memory Usage on the bottom portion of the IPG tab, similar to the following example.

The screenshot shows the 'Set Up Global DHCT Configuration' window in the Cisco DNCS/DHCT Configure interface. The window title is 'Set Up Global DHCT Configuration' and it includes a Cisco logo in the top right corner. The interface is divided into several sections:

- Name:** global
- Last Modified:** 12/13/2011 05:10:49 AM
- Navigation Tabs:** Base Application, PIN Entry, General Settings, Barkers, Quick Settings, IPV, Misc Settings, **IPG**
- Initial View:** Browse by: Time
- Options:**
  - Display 'Browse by' menu
  - Highlight current program
  - Show Tuned Channel Banner
  - Show visual cue for unauthorized channels
- Behaviour:**
  - IPG Scrolls: 10 minutes before the half hour
  - MSO Logo Position:  Left  Right
  - Numeric Key Response: Exit IPG, tune to channel
  - Show button:  Yes  No Icon or Label  Icon  Label Base
- Memory Usage:**
  - Leave Largest Contiguous Free KB: 512
  - Additional Total Free In Excess of Largest Contiguous KB: 256
  - Use Fixed Size Grid File Data Allocations KB(0=variable): 0 (disabled)

At the bottom of the window are 'Save' and 'Cancel' buttons.

The Memory Usage section at the bottom of the window allows you to adjust how the IPG utilizes memory. These settings are also available on the hub-specific IPG tab. You can use hub-specific settings to test the settings on a hub in the headend before applying the settings to the entire site.

A message appears to the right of Use Fixed Sized Grid File Data Allocations KB (0=variable). This message provides information about the value currently entered. When this setting is enabled, the message provides the minimum value required, based on the size of the largest grid data file on the SARA server's disk.

The IPG Memory Usage fields display the following information about how the IPG utilizes memory.

Field Name	Description and Possible Values
<b>Leave Largest Contiguous Free KB</b>	<p>The value in this field indicates, in kilobytes, the minimum amount of contiguous free memory ("largest contiguous free block") that the IPG daemon in the set-tops must see available in order to download IPG files in the background.</p> <p><b>Note:</b> This field requires a minimum value of 50 KB.</p> <p><b>Default setting:</b> 512 KB</p>
<b>Additional Total Free in Excess of Largest Contiguous KB</b>	<p>The value in this field indicates, in kilobytes, the minimum amount of additional free memory above and beyond the largest contiguous block that the IPG daemon in the set-tops must see available in order to download IPG files in the background. For example, if <b>Leave Largest Contiguous Free KB</b> is set to 512 and <b>Additional Total Free in Excess of Largest Contiguous KB</b> is set to 256, then there must be at least 768 KB of total free memory.</p> <p><b>Default setting:</b> 256 KB</p>

**Notes:**

- These two settings are used in combination by the DHCT's IPG Daemon. If either the "largest contiguous free" block of memory or "total free" memory have fallen below the thresholds, additional files will not be downloaded in the background unless the available memory grows back above the threshold.
- These two thresholds do not restrict background loading of the grid nor description data files for the current or next day unless they are configured as "Automatic Priority-Based Purging".
- The above two thresholds do not restrict loading of files when requested by the IPG UI (user-initiated).
- The above thresholds are examined before downloading files, therefore if the desire is to ensure that the IPG always leaves a certain amount of memory free, then the thresholds need to be adjusted to accommodate the typical largest size of the site's IPG grid data files. In other words, if the desire is to ensure there is at least 512 KB contiguous free after loading data, and the site's grid data files are at most 300 KB (for example), then the value needs to be set to 512+300, or 812 KB.

Field Name	Description and Possible Values
Use Fixed Size Grid File Data Allocations KB (0-variable)	<p>This setting affects only the grid data, not the long descriptions. The value entered in this field determines whether this setting is enabled or disabled.</p> <ul style="list-style-type: none"> <li>■ <b>Disabled</b> - A zero in this field indicates that this setting is disabled.</li> </ul> <p><b>Note:</b> Disabled is the default setting.</p> <ul style="list-style-type: none"> <li>■ <b>Enabled</b> - When enabled, this field requires a value that is a minimum of 10% larger than the largest grid data file on the Application Server's disk.</li> </ul> <p><b>Important:</b> When using this setting, we recommend that each week you verify the allocated size against the actual file sizes and, if needed, increase the allocated file size.</p> <p><b>Notes:</b></p> <ul style="list-style-type: none"> <li>- When using this setting, the Information bar indicates the range of values allowed based on the size of the largest grid data file, or displays that no grid data files have been found when this is the case.</li> <li>- Entering a value in this field also causes a message to appear to the right of the field that provides the minimum required value.</li> <li>- This fixed size allocation applies only to the grid data for days configured as "Never Purge."</li> <li>- When this value is changed, the Application Server will attempt to resize the memory allocations for "Never Purge" days when the new configuration data is received. However, under tight memory conditions, the resizing may not occur until much later (resizing is attempted periodically) and, if it has not been able to resize the allocated memory to the newly configured fixed size by midnight, when the days get changed, the existing allocations might be deleted, and then a new allocation to the proper size will be attempted.</li> </ul>

The following IPG Memory Usage settings define when grid data for the current day and next day will be purged.

- Never Purge
- Automatic Priority-Based Purging
- Purge Only When Asked By Another App

Field Name	Default Setting
<b>Current Day</b>	
Data Grid	Never Purge  <b>Important:</b> This setting must not be more purgeable than the setting for the Current Day Descriptions, the setting for Next Day Data Grid, or the setting for Next Day Descriptions.
Descriptions	Purge Only When Asked By Another App  <b>Important:</b> This setting must not be more purgeable than the setting for the Next Day Data Descriptions.
<b>Next Day</b>	
Data Grid	Never Purge  <b>Important:</b> This setting must not be more purgeable than the setting for the Next Day Descriptions.
Descriptions	Automatic Priority-Based Purging  <b>Important:</b> This setting must not be more purgeable than the setting for the Current Day Data Grid.

## Automatic Purging of IPG Data

From time to time, the operating system may purge IPG descriptions or future grid data in order to fulfill a more urgent memory allocation request. Each IPG memory cache is marked with a purge priority, which determines which information should be purged first. Important data is marked with a higher number, so the operating system purges data with lower numbers first. The memory usage scheme is as follows:

- Data for the current day is always locked in memory, so it is never purged.\*
- Data for the next day is always locked in memory, so the OS cannot purge it.\*  
*However, SARA will purge this data as a last resort before unloading apps to get memory.*
- Descriptions for the current day can be purged at priority 3 when idle or priority 8 when the IPG is active.
- Descriptions for the next day can be purged at priority 1 when idle or priority 6 when the IPG is active.
- All grid data for future days can be purged at priority 0 when idle or priority 5 if the IPG is active. This data is locked and cannot be purged while the IPG is displaying data for that day.
- All descriptions for future days can be purged at priority 0 when idle or priority 5 when the IPG is active. (When idle, all future days descriptions should already

be automatically purged by the IPG daemon.)

\*This is true for older Application Servers; however, newer Application Servers give you additional flexibility. In the DNCS IPG GUI, you can now set Current and Next Day to allow purging.

## Adjust How DHCTs Use IPG Memory

This section provides instructions for sending IPG Memory Usage settings to DHCTs. Sending these settings to DHCTs allows you to fine tune how DHCTs use IPG memory. You can use either of the following methods to send these settings to DHCTs:

- **Global:** Sends the settings to all DHCTs in your network.
- **Hub-Specific:** Sends the settings to DHCTs in a specific hub. This method allows you to test the settings on DHCTs in the headend before applying the settings to all DHCTs in your network.

This section also provides instructions for modifying settings for a hub and for changing hub settings to global settings.

### Sending IPG Memory Usage Settings to All DHCTs in a Specific Hub

Sending settings to all DHCTs in a hub requires that you first enable the settings for use on a hub-specific basis. Once hub-specific settings are enabled, you can configure each setting for any hub in your network. Until you enable these settings, they will be unavailable for you to configure and send to DHCTs in a specific hub.

#### To Enable Hub-Specific Memory Usage Settings

Follow these instructions to enable hub-specific IPG Memory Usage settings.

- 1 On the DNCS Administrative Console, select the **Server Applications** tab.
- 2 Click **DHCT Config**. The DHCT Configure window opens.
- 3 Click **Hub**. The Hub List window displays all of the hubs in your network along with their IDs and configurations.

**Note:** The Configuration field indicates whether the hub uses the standard global configuration or a hub-specific configuration.

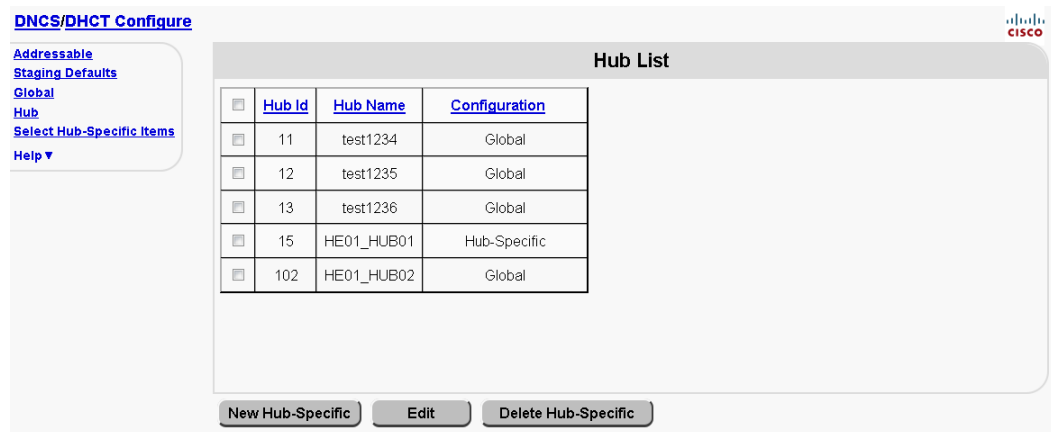

The screenshot shows the 'DNCS/DHCT Configure' window with a sidebar on the left containing links for 'Addressable', 'Staging Defaults', 'Global', 'Hub', 'Select Hub-Specific Items', and 'Help'. The main area is titled 'Hub List' and contains a table with the following data:

<input type="checkbox"/>	Hub Id	Hub Name	Configuration
<input type="checkbox"/>	11	test1234	Global
<input type="checkbox"/>	12	test1235	Global
<input type="checkbox"/>	13	test1236	Global
<input type="checkbox"/>	15	HE01_HUB01	Hub-Specific
<input type="checkbox"/>	102	HE01_HUB02	Global

At the bottom of the window are three buttons: 'New Hub-Specific', 'Edit', and 'Delete Hub-Specific'.

- 4 Click **Select Hub Specific-Items**. The Select Hub-Specific Items window opens.

- 5 Click the **IPG** tab. The IPG tab moves to the forefront and displays the settings that are available for selection.
- 6 In the Memory Usage area of the tab, select each setting that you want to be able to configure at the hub level.

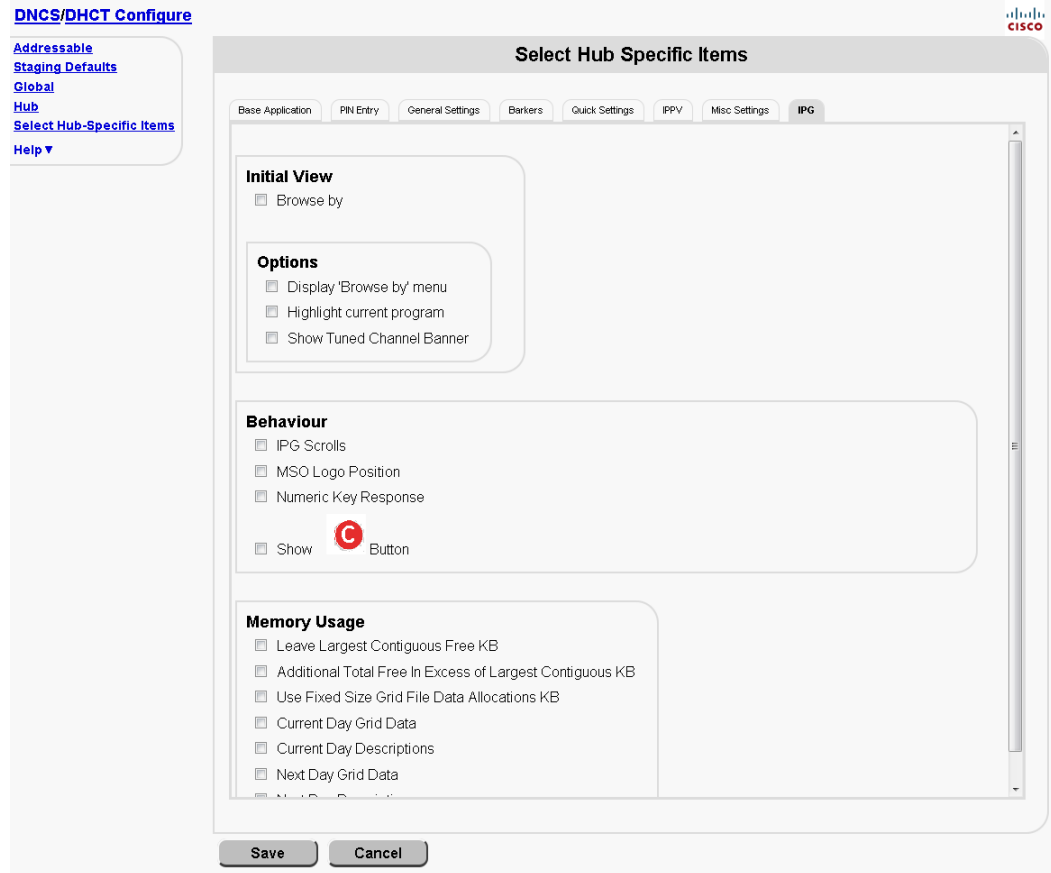

- 7 Click **Save**. These selections are made available to all hubs and the Select Hub-Specific Items window closes. You can now configure and send IPG Memory Usage settings to DHCTs in a hub. Go to *To Send IPG Memory Usage Settings to All DHCTs in a Hub* (on page 91).

### To Send IPG Memory Usage Settings to All DHCTs in a Hub

After you have enabled hub-specific IPG Memory Usage settings, follow these instructions to configure and send them to all DHCTs in a hub.

- 1 On the DNCS Administrative Console, select the Server Applications tab.
- 2 Click **DHCT Config**. The DHCT Configure window opens.
- 3 Click **Hub**. The DHCT Configure window displays all of the hubs in your network along with their IDs and configurations.

**Note:** The Configuration field indicates whether the hub is set to the standard, Global configuration or whether it uses a Hub-Specific configuration.

- 4 Select the hub whose IPG Memory Usage settings you want to configure. The hub you selected is highlighted.
- 5 Click **New Hub-Specific**. The Set Up Hub DHCT Configuration window appears.
- 6 Click the **IPG** tab. The IPG tab moves to the forefront and displays the default Memory Usage settings.
- 7 Are the Memory Usage settings available?
  - If **yes**, continue with the next step in this procedure.
  - If **no**, the settings are dimmed because they have not been enabled for hub-specific configurations. see *To Enable Hub-Specific Memory Usage Settings* (on page 90).
- 8 Enter the settings appropriate for this hub.

**Note:** For an explanation of Memory Usage settings, see *IPG Memory Usage Settings* (on page 84).
- 9 When finished, click **Save**. The Application Server sends the configuration to all of the DHCTs in the hub you specified. Changes should be made to DHCTs within a few minutes.
- 10 Do you want to send this configuration to another hub in your network?
  - If **yes**, repeat steps 4 to 9 for each hub that you want to change.
  - If **no**, you are finished with this procedure.

## Modifying IPG Memory Usage Settings for DHCTs in a Specific Hub

If for any reason you need to change memory usage settings for DHCTs in a specific hub, follow these instructions.

- 1 On the DNCS Administrative Console, select the **Server Applications** tab.
- 2 Click **DHCT Config**. The DHCT Configure window opens.
- 3 Click **Hub**. The Hub List window displays all of the hubs in your network along with their IDs and configurations.
- 4 Select the hub whose IPG Memory Usage settings you want to change. The hub you selected is highlighted.
- 5 Click **Edit**. The Set Up DHCT Configuration window for the hub you selected opens.
- 6 Click the **IPG** tab. The IPG tab moves to the forefront.
- 7 Change the Memory Usage settings you desire.
- 8 When finished, click **Save**. The Application Server sends the configuration to all of the DHCTs in the hub you specified. Changes should be made to DHCTs within a few minutes.

## Sending IPG Memory Usage Settings to All DHCTs in Your Network

Once you have completed testing the Memory Usage settings on the DHCTs in your headend, follow these instructions to send these settings globally to all DHCTs in your network that do not receive hub-specific settings. After these settings are applied globally, you will be able to change any hub-specific settings to those of the global settings if you wish.

- 1 On the DNCS Administrative Console, select the **Server Applications** tab.
- 2 Click **DHCT Config**. The DHCT Configure window opens.
- 3 Select **Global**. The Set Up Global DHCT Configuration window opens.
- 4 Click the **IPG** tab. The IPG tab moves to the forefront and displays the default Memory Usage settings.

The screenshot shows the 'Set Up Global DHCT Configuration' window in the DNCS/DHCT Configure interface. The window title is 'Set Up Global DHCT Configuration' and it shows the 'IPG' tab selected. The 'Name' field is set to 'global' and the 'Last Modified' date is '12/13/2011 05:10:49 AM'. The 'Initial View' section has a 'Browse by' dropdown set to 'Time'. The 'Options' section has four checkboxes: 'Display 'Browse by' menu' (unchecked), 'Highlight current program' (unchecked), 'Show Tuned Channel Banner' (checked), and 'Show visual cue for unauthorized channels' (unchecked). The 'Behaviour' section has 'IPG Scrolls' set to '10 minutes before the half hour', 'MSO Logo Position' set to 'Right', 'Numeric Key Response' set to 'Exit IPG, tune to channel', and 'Show button' set to 'Yes' with a red 'C' icon. The 'Memory Usage' section has 'Leave Largest Contiguous Free KB' set to '512', 'Additional Total Free In Excess of Largest Contiguous KB' set to '256', and 'Use Fixed Size Grid File Data Allocations KB(0=variable)' set to '0 (disabled)'. There are 'Save' and 'Cancel' buttons at the bottom.

- 5 Enter the settings appropriate to your network.  
**Note:** For an explanation of Memory Usage settings, see IPG Memory Usage Settings.
- 6 When finished, click **Save**. The Application Server sends these settings to all DHCTs in your network that do not receive hub-specific settings. Changes should be made within a few minutes.

**Note:** These changes do not affect DHCTs that receive hub-specific configurations.

## Changing a Hub-Specific Configuration to a Global Configuration

Once you have completed testing the Memory Usage settings on the DHCTs in your headend, follow these instructions to send these settings globally to all DHCTs in your network that do not receive hub-specific settings. After these settings are applied globally, you will be able to change any hub-specific settings to those of the global settings if you wish.

- 1 On the DNCS Administrative Console, select the **Server Applications** tab.
- 2 Click **DHCT Config**. The DHCT Configure Prompt window opens.
- 3 Click **Hub**. The DHCT Configure Prompt window displays all of the hubs in your network along with their IDs and configurations.
- 4 Select the hub that you need to change from Hub-Specific to Global configuration.
- 5 Click the **File** menu and select **Delete Hub-Specific**. A message asks if you are sure you want to delete the hub-specific configuration.
- 6 Click **Yes** to delete the hub-specific configuration.

## Selecting the Number of Days of IPG Data to Produce

You can set the IPG to produce up to 28 days of data. Follow these steps to specify how many days of data the IPG should produce.

- 1 From the DNCS Administrative Console, click the **Server Applications** tab.
- 2 Click **IPG**. The IPG Server List window opens.

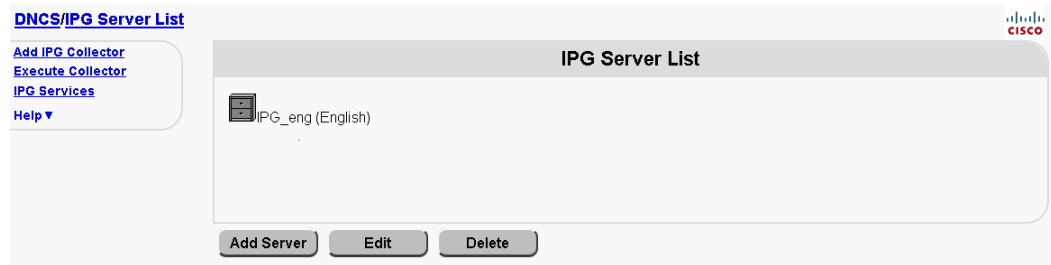

- 3 Select the server that you want to modify, then click **Edit**. An information message appears.
- 4 Click **OK** to acknowledge the information message. The Edit IPG Server window opens, similar to the following example.

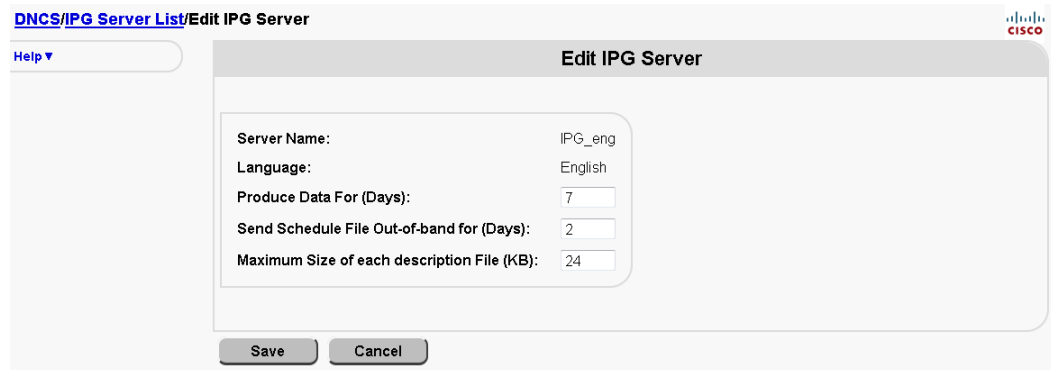

- 5 In the **Produce data For** field, type the number of days of IPG data that you want to download.
- 6 Click **Save** to save the changes, then click **Cancel** to close the window.

## Graying Out Unauthorized Channels in IPG

You can choose to gray out, or "shade" unauthorized channels in the IPG, so that subscribers can tell which channels are not authorized. Follow these steps to gray out unauthorized channels:

- 1 On the DNCS Administrative Console, select the **Server Applications** tab.
- 2 Click **DHCT Config**. The DHCT Configure window opens.
- 3 Click **Global**. The Set Up Global DHCT Configuration window opens.
- 4 Click the **IPG** tab.
- 5 Select the checkbox beside **Show visual cue for unauthorized channels**.

The screenshot shows the 'Set Up Global DHCT Configuration' window with the 'IPG' tab selected. The 'Options' section contains the following settings:

- Display 'Browse by' menu
- Highlight current program
- Show Tuned Channel Banner
- Show visual cue for unauthorized channels

The 'Behaviour' section contains the following settings:

- IPG Scrolls: 10 minutes before the half hour
- MSO Logo Position:  Left  Right
- Numeric Key Response: Exit IPG, tune to channel
- Show button:  Yes  No Icon or Label  Icon  Label Base

At the bottom of the window are 'Save' and 'Cancel' buttons.

- 6 Click **Save** to apply the changes, then click **Cancel** to close the window.

## Configure the ISDP for EPG Search

### Before You Begin

Before you begin configuring EPG search capabilities for your site, you must make sure that the CDS Navigation Server has been installed with a network connection to your ISDS. Be sure that you can ping the CDS Navigation Server before you continue.

In addition, you will need the IP address of your CDS Navigation Server to configure EPG search capabilities. Write the IP address of your CDS Navigation Server in the following space: \_\_\_\_\_

#### Notes:

- Refer to *Cisco TV CDS 2.2 Installation, Upgrade, and Maintenance Guide* (OL-22246-01) for information about setting up the CDS Navigation Server.
- Depending on the way your network is set up, you may need to set persistent routes to the CDS Navigation Server. Check with your IT department to see if this is the case. See *Setting Persistent Routes (Optional)* (on page 101) for more information.

### Configure the ISDP

Follow these steps to set up the ISDP for EPG search.

- 1 On the ISDS Administrative Console, select the **System Provisioning** tab and then select the **VOD params tabs**. The VOD Applications screen appears.

- 2 Add a new entry for the VOD Navigator, as shown in the following example.

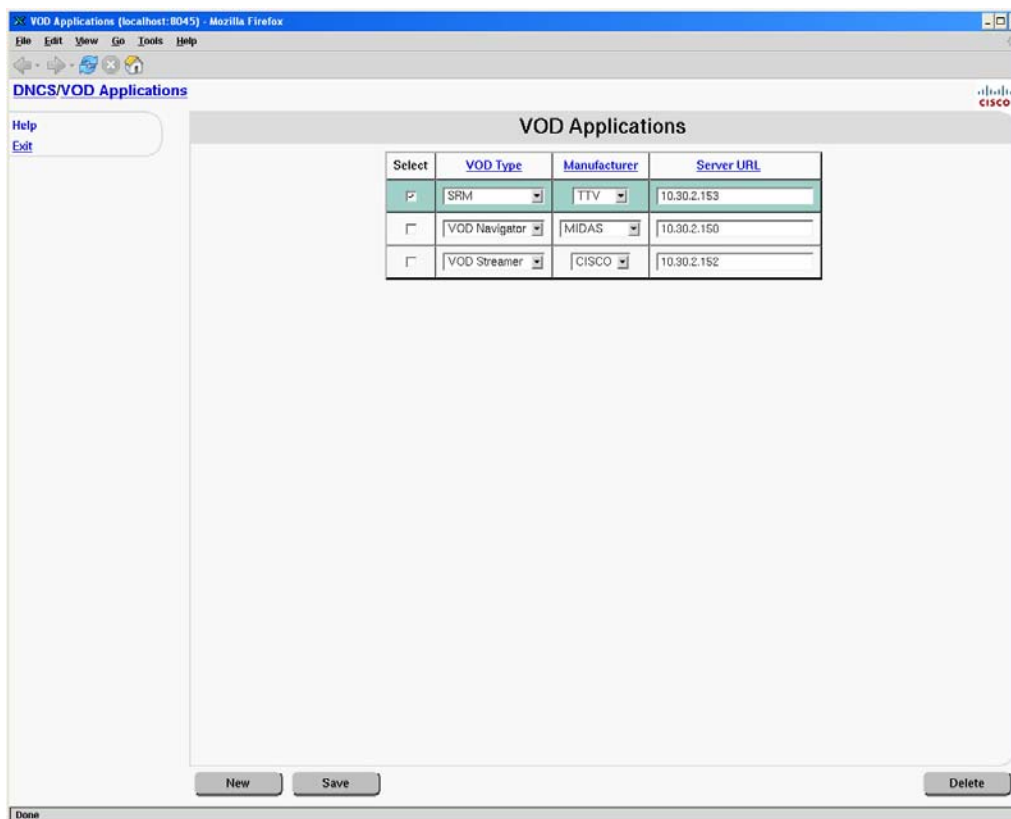

**Note:** If you are running ISDS version 2.2.0.1 or earlier, you may need to bounce all of the hctm\* processes to update the unconfig params.

- 3 Add the following information to the dncls .profile file. Replace the IP address in the example with the IP that is set on the MIDAS server.

```
export MIDAS_SEARCH_SERVER_IP=xxx.xxx.xxx.xxx
export MIDAS_SEARCH_URLBASE=/MIDAS/EPGHttpServer/
```

- 4 Re-source the shell env to take effect and check with >echo \$env variable.
- 5 Type `cd /dvs/appserv/etc` and press **Enter**.
- 6 Does your site already support VOD?
  - If **yes**, add the following information to the application server configuration file (midas.env). Replace the IP address in the example with the IP that is set on the MIDAS server.
  - If **no**, create a new application server configuration file (midas.env) with the following information. Replace the IP address with the IP that is set on the MIDAS server.

```
MIDAS_SEARCH_SERVER_IP=xxx.xxx.xxx.xxx
MIDAS_SEARCH_URLBASE=/MIDAS/EPGHttpServer
MIDAS_SEARCH_UPLOAD_TYPE=epg
```

- 7 Enter the following commands to stop and restart the application server process:

```
cd /dvs/appserv/bin
appStop
appStart
```

## Create a Package to Enable EPG Search

Depending on how you plan to offer EPG search, you must either create a new package or assign EPG search to an existing package:

- If EPG search will be a premium feature (only available to subscribers who pay extra for the service), then you must create a new package to enable the service. Go to *Create a Package* (on page 99).
- If you plan to offer EPG search to all subscribers, then you can assign the feature to the basic package. Go to *Determine the EID Value* (on page 100).

### Create a Package

If your site will offer EPG search as a premium feature, follow these steps to create a new package.

- 1 On the ISDS Administrative Console, click **Package** from the System Provisioning tab. The Package List window opens.
- 2 Select **Add** to open the Add Package window.

The screenshot shows the 'Add Package' window with the following details:

- Package Name:** [Yellow highlighted text box]
- Package Description:** [Empty text box]
- Default Staging Package:**
- Utility Package:**
- Non-PowerKEY Package:**
- Duration:**  Unlimited  Limited
- Start Date:** MM/DD/YYYY 02/21/2012 [Select]
- Start Time:** HH:MM:SS [AM]
- Length:** 0 days 0 hours 0 minutes
- Pay Per View:**
- Right To Copy:**  Allowed
- Allow Event Extension:**
- Impulse Pay Per View:** 
  - Preview:**  Buy Window Purchase Modes
  - Start Date:** MM/DD/YYYY 02/21/2012 [Select]
  - Start Time:** HH:MM:SS [AM]
  - Duration:** [ ] hours [ ] minutes
- Buttons:** Save, Cancel

- 3 Type a name for the package in the Package Name field. This name should be descriptive so that you can identify the package later (for example, "EPG Search").

#### Notes:

- Be sure that this package name is compatible with your billing system requirements.

- Leave all other fields in this window set to their default values.
- 4 Click **Save**. The package is created.

#### Determine the EID Value

Follow these steps to determine the EID value of the service you want to authorize.

- 1 Open the package that you will use to authorize EPG search and record the EID value here: \_\_\_\_\_.  
**Note:** If your site will offer EPG search as a premium service, then this is the package that you just created.
- 2 Click **Cancel** to close the Set Up Package window.
- 3 In the Package List window, select **File > Close** to close the window.

## Create a SAM Service

Complete the following steps to create a SAM service for EPG Search.

- 1 From the ISDS Administrative Console, select the **Application Interface Modules** tab.
- 2 Click the **SAM Service** button. The SAM Service List window opens.
- 3 Click **Add**. The Add SAM Service window opens.
- 4 Enter the SAM Service information as follows:
  - **Service Name** (required) - This name is only available and shown to users of the ISDS who have access to the SAM Services List. Make this descriptive enough to understand which service is being offered. End users will not see this field.
  - **Short Description** (required) - Enter **\_EPGS**. The set-top UI will use this short description to determine if this service is being provisioned.
  - **Long Description** - The long description will be used for meaningful display to the user. The Long Description will appear in the Menu and/or in the grid cell of the electronic programming guide (EPG), as indicated by the options in the "Application URL", described below.
  - **Application URL** - Enter **eid=<EID value>**; using the the EID information you recorded in *Determine the EID Value* (on page 100). The application URL provides additional information for how the service can be accessed.
  - **Logo** - Enter **0**. A default logo will be displayed.
  - **Parameter** - Select the bullet next to **Number** and type **0** in the field.

### Example: Add SAM Service Window

The screenshot shows the 'Add SAM Service' window. It includes the following fields and controls:

- Service ID:** A text input field.
- Service Name:** A text input field.
- Short Description:** A text input field with a yellow highlight.
- Long Description:** A text input field.
- Application URL:** A text input field containing 'bfs://resapp/watchtv' and a 'Select...' button.
- Logo:** A text input field.
- Parameter:** Radio buttons for 'Number' (selected) and 'String'.
- Buttons:** 'Save' and 'Cancel' buttons at the bottom.

- 5 Click **Save**.

## Verify that EPG Search Works

Before you can verify that EPG search works as expected, the IPG collector must be run. Normally, this occurs overnight, but you can check the EPG search functionality immediately by completing the following steps:

- 1 Run the IPG collector.
- 2 Authorize the set-top for the package.
- 3 Reboot the set-top box.
- 4 Press **Guide** and then select **Search** to see if EPG search works as expected. Then verify that EPG search is available from the main TV menu.

## Setting Persistent Routes (Optional)

Depending on your configuration, you may need to change the routes in your routing table and make them persistent. Follow these steps if you need to set persistent routes.

- 1 On the ISDS as root user, type **cd sysconfig/** and press **Enter**.
- 2 Type **cd network-scripts/** and press **Enter**.
- 3 Type **vi route-eth0** and press **Enter** to edit the route-eth0 file.

### Example:

```
GATEWAY0=10.90.160.1
NETMASK0=255.0.0.0
ADDRESS0=64.0.0.0
GATEWAY1=10.90.160.1
NETMASK1=255.255.255.0
```

```
ADDRESS1=10.90.161.0
```

- 4 Change the GATEWAY IP addresses as needed, then save and close the file.
- 5 Type **vi route-eth1** and press **Enter** to edit the route-eth1 file.

**Example:**

```
GATEWAY0=192.168.100.254  
NETMASK0=0.0.0.0  
ADDRESS0=0.0.0.0
```

- 6 Change the GATEWAY0 IP address as needed, then save and close the file.
- 7 Restart the network for the changes to take effect.
- 8 When you finish, you can type **netstat -rn** and press **Enter** to verify that the correct routes are listed.

**Example:**

Kernel IP routing table

Destination Iface	Gateway	Genmask	Flags	MSS Window	irrt
192.168.100.0	0.0.0.0	255.255.255.0	U	0 0	0 eth1
10.90.161.0	0.0.0.0	255.255.255.0	U	0 0	0 eth0
10.90.160.0	0.0.0.0	255.255.255.0	U	0 0	0 eth0
169.254.0.0	0.0.0.0	255.255.0.0	U	0 0	0 eth1
64.0.0.0	10.90.160.1	255.0.0.0	UG	0 0	0 eth0
0.0.0.0	192.168.100.254	0.0.0.0	UG	0 0	0 eth1

# 7

## Setting Up a Virtual Channel Service

Virtual channels are channels that display text (using a special limited HTML command set) when a subscriber tunes to them. The file that contains the information must be on the Application Server. This information may include announcements of civic organizations, community organizations, or local businesses.

Video service providers use this service to provide a variety of information to subscribers. Virtual channels are typically available to all subscribers. These are not "real" RF channels. They allow the cable operators to create text channels (usually information channels) without using RF spectrum.

The Virtual Channel Server (VCS) interacts with the BFS, SAM, and Channel Map to provide services to the DHCTs that display text information. This section describes how to configure the VCS BFS, how to build or edit a virtual channel source file, and how to set up virtual channels and register them with the SAM and BFS to make the service available to subscribers.

**Important:** Building and editing a virtual channel source file requires a thorough knowledge of HTML. The instructions provided in this chapter are no substitute for a thorough knowledge of HTML.

### In This Chapter

- Configure the VCS Broadcast File System (BFS) ..... 104
- Build a Virtual Channel Source File ..... 108
- Set Up a Virtual Channel Service ..... 111

## Configure the VCS Broadcast File System (BFS)

Typically during a system upgrade, the installer configures the BFS by adding a virtual channel server to the BFS. However, if this procedure was not performed at the time of upgrade, use the following procedures to check or configure a BFS server for the virtual channel service.

In earlier releases of the Application Server, virtual channel files could only exist on BFS Source ID 2 (inband) with other OSM files such as PowerTV® and the Application Server ROM. With recent modifications to the arrangement of alternating BFS files, small virtual channel server files now circulate very slowly, and leave the virtual channels practically useless. To resolve this issue, you must move the virtual channel files to a new source. Doing so allows the BFS to update the information it sends to the DHCTs and the virtual channels can then appear faster.

**Important Note for Multiple-Site (RCS-Enabled) Systems:** Manually setting up any BFS server or source for the Application Server's use must be done for the "AllSites" site only, and not for any other individual sites in your system. Otherwise, the server and source will fail.

### Procedure at a Glance

To configure the BFS for the virtual channel server, complete the following steps.

**Note:** For detailed instructions on adding a VCS application to the BFS, refer to *Adding and Removing Applications on the BFS For System Release 2.5/3.5 and 4.0* (part number 4011048).

- 1 Create a new digital source with the following characteristics in the Source List window:

- **Source Name:** You can enter any name that helps you to remember the service this source provides. For example, you might use "VCS BFS Source."
- **Source ID:** An unused even number that is greater than 200.

**Note:** To define these characteristics, display the Set Up Source window by following this quick path: DNCS Administrative Console > DNCS tab > System Provisioning tab > Source > File > New.

- 2 Create a new source definition with the following characteristics in the Source Definition List window:

- **Session ID:** 00:00:00:00:00:00 plus the number used for the Source ID
- **Session Definition:** BFS

**Note:** To define these characteristics, display the Set Up Digital Source Definition window, by following this quick path: DNCS Administrative Console > DNCS tab > System Provisioning tab > Source > [Select Source] > File > Source Definitions > File > New Digital.

- 3 Add a source with the following characteristics to the Sources tab of the BFS Administration window:

**Important:** Multi-site (RCS-enabled) systems should use the All Sites tool to add a source to the Sources tab on the Site AllSites BFS Administration window.

- **Source Name:** Use the same name that you used for the Source Name in step 1
- **Source ID:** Use the same number that you used for the Source ID in step 1
- **Source Type:** BFS
- **Transport Type:** ASI In-band or In-band
- **Data Rate:** 0.5 Mbps or less

**Note:** You may also use a value as low as 0.1 Mbps. The maximum rate you can enter for inband data is 2.00 Mbps. For assistance, refer to *Recommendations for Data Carousel Rate Management Technical Bulletin* (part number 716377).

- **Block Size and Indication Interval:** Use the default values
- **Selected Hosts:** Select the host according to your system configuration:

- For single-site systems, select **dnccsatm**
- For multiple-site (RCS-enabled) systems, select **AllSitesHost**

**Note:** To define these characteristics, display the Set Up BFS Source window by following the quick path for your system configuration:

- **Single-Site System:** DNCS Administrative Console > Application Interface Modules tab > BFS Admin > Sources tab > File > New
- **Multi-Site System:** DNCS Administrative Console > Application Interface Modules tab > BFS Admin > File > All Sites > Sources tab > File > New

- 4 Add a server with the following characteristics to the Servers tab in the BFS Administration window:

**Important:** Multi-site (RCS-enabled) systems should use the All Sites tool to add the server with the following characteristics to the Servers tab in the Site AllSites BFS Administration window.

- **Server Name:** VCS
- **Selected Sources List:** VCS Source

**Note:** To define these characteristics, display the Authorize BFS Server window by following the quick path for your system configuration:

- **Single-Site System:** DNCS Administrative Console > Application Interface Modules tab > BFS Admin > Servers tab > File > New
- **Multi-Site System:** DNCS Administrative Console > Application Interface Modules tab > BFS Admin > File > All Sites > Servers tab > File > New

- 5 Register the server with the BFS Client by adding a server with the following characteristics to the Broadcast File Server List window:

- **Server Name:** VCS
- **Mode:** One-way
- **Selected Sources:** VCS

**Note:** To define these characteristics, display the Set Up Server window by following the quick path for your system configuration:

- **Single-Site Systems:** DNCS Administrative Console > Application Interface Modules tab > BFS Client > File > New Server
- **Multi-Site Systems:** DNCS Administrative Console > Application Interface Modules tab > BFS Client > File > All Sites > File > New Server

- 6 Configure the new BFS server source ID on the virtual channel server. For assistance, go to *Configuring the New BFS Server Source ID* (on page 106).

## Configuring the New BFS Server Source ID

The final step in configuring the BFS source ID is to configure the new BFS server source ID on the server. Perform the following steps to configure the BFS server source ID.

- 1 On the DNCS Administrative Console, select the **Server Applications** tab.
- 2 Click **VCS**. The VCS List window opens.

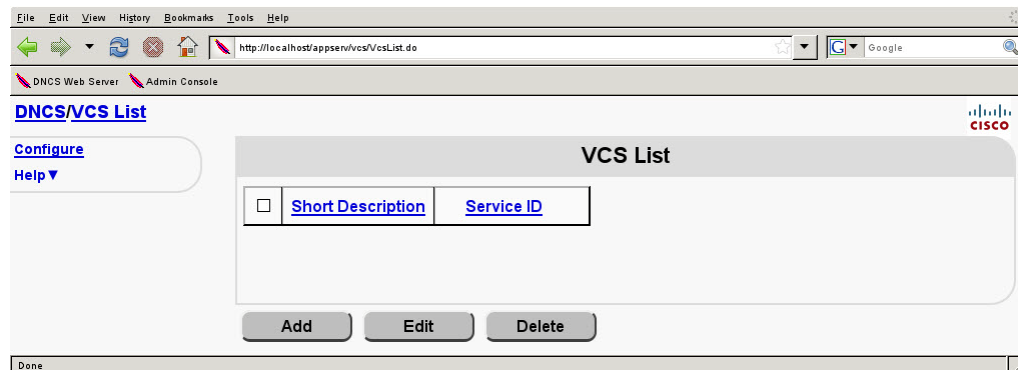

- 3 Click **Configure**. The Configure VCS window opens.

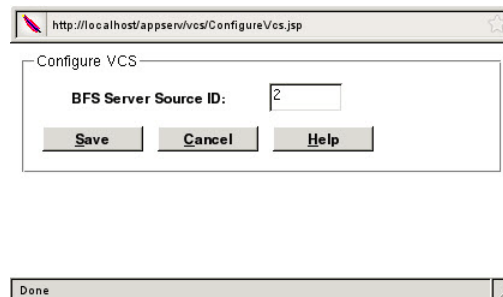

## Configure the VCS Broadcast File System (BFS)

- 4 Verify that the number that appears in the BFS Server Source ID field matches the BFS server source ID you created earlier, then click **Save** to return to the VCS List window.
- 5 On the Application Server, run appControl.
- 6 In the appControl window, stop and restart the VC server group. Approximately 1 minute after the server restarts, the BFS sends the updated information to the DHCTs. This update means that the virtual channels take less time to display when a subscriber tunes to the channel.
- 7 Verify that the virtual channels operate correctly.

## Build a Virtual Channel Source File

When building a virtual channel source file, you must first complete the following tasks.

- 1 Create the source HTML files for the virtual channel client to use.
- 2 Save the source HTML files to the appropriate directory on the Application Server.

Although this section provides procedures for building a source file for a virtual channel, a thorough knowledge of HTML is required to perform these procedures successfully. The instructions provided in this section are no substitute for a thorough knowledge of HTML.

### Creating the Source HTML Files

These files provide the content for a virtual channel in the same way that a local studio or satellite feed provides content for a clear broadcast. Therefore, by creating the HTML file, you create a source for the virtual channel service.

You can use any HTML editor to create a document that contains the information you want the subscriber to see. However, when formatting the text you can only use the tags in the following table.

**Important:** The behavior of the Virtual Channel client is unpredictable if you use any tags that do not appear in the following table to create an HTML document. Only these tags are supported because the Application Server client uses the Virtual Channel application (not a standard, full-featured browser) to read the source file.

Tag	Meaning
<code>&lt;b&gt;&lt;/b&gt;</code>	Display text between tags as bold text
<code>&lt;big&gt;&lt;/big&gt;</code>	Display text between tags as large text
<code>&lt;br&gt;</code>	Insert blank rule (line break)
<code>&lt;br1.5&gt;</code>	Insert 1.5 blank rules (1.5 line break)
<code>&lt;center&gt;&lt;/center&gt;</code>	Display text and images between tags as horizontally centered on the line
<code>&lt;img scr="ok.img"&gt;</code>	Display the SELECT button
<code>&lt;img scr="a.img"&gt;</code>	Display the A button
<code>&lt;img scr="b.img"&gt;</code>	Display the B button
<code>&lt;img scr="c.img"&gt;</code>	Display the C button
<code>&lt;img scr="settings.img"&gt;</code>	Display the SETTINGS button
<code>&lt;font color="white"&gt;</code>	Change the font color to white
<code>&lt;font color="black"&gt;</code>	Change the font color to black

Tag	Meaning
<font color="yellow">	Change the font color to yellow
<table bgcolor="alert"></table>	Applies a standard 3-row alert-banner background to the table
<table bgcolor="swirl"></table>	Applies a purple swirl graphic to the background of the table
<table bgcolor="none"></table>	Applies a transparent background to the table
<tr>	Define a table row. (For alert banner background, there must be at least three rows per table)

**Example:** The following is a sample HTML document with the recommended tags for a Virtual Channel client.

```

<table bgcolor="alert">
<tr>
<font color="yellow">
<center><big><b>ACME CABLE TV</b></big></center><br>
<center><big><b>Job Line</b></big></center><br>
<font color="white"><center><b>Professional, Technical and Managerial</b></center>
<tr>
<font color="black">
JOB:           Sales Engineer III<br>
LOCATION:       Suwanee<br>
SALARY:       $20.82 / HR Full-time<br>
EDUCATION:    4 YR Degree<br>
TELEPHONE:    (404) 555-5555
<tr>
<font color="black">
<center><b>JOBS PRESENTED FROM THE ACME INC. WORK LINE.</b></center><br>
<center>Call (404) 555-5555 for more information or to post a job
opening.</center>

```

## Saving the Source HTML Files

After creating the source HTML files using the appropriate tags, you must save the files in the /dvs/appFiles/html directory on the DNCS. Use the parse utility in the /dvs/appserv/bin directory to verify that the Virtual Channel client can display your files.

Perform the following steps to run the parse utility.

- 1 Create two directories.
- 2 Name one **good** and the other **bad**.
- 3 Save them in the /dvs/appFiles/html directory. The following three directories appear for HTML files:
  - /dvs/appFiles/html
  - /dvs/appFiles/html/good

- /dvs/appFiles/html/bad
- 4 In an xterm window, type **parse goqam** to run the parse utility. One of the following results occurs:
- If the Virtual Channel can use your HTML file, the parse utility displays the following:  
**Parsed file <file.html>, no errors found.**  
**Moved the file to <good/file.html>.**
  - If the Virtual Channel cannot use your HTML file, the parse utility displays the following:  
**Parsed file <file.html>, errors found.**  
**Moved the file to <bad/file.html>.**  
**Please look at <bad/file.err> for details**  
**Note:** File.err lists line numbers of any lines of text that use HTML tags not recognized by the Virtual Channel client.

# Set Up a Virtual Channel Service

## Overview

When setting up a virtual channel service, you must first complete the following tasks.

- 1 Set up the virtual channel service.
- 2 Place the virtual channel service on the Channel Map.

This section provides procedures for completing these tasks, as well as for modifying a virtual channel configuration, editing a source file, and deleting a virtual channel.

## Setting Up the Virtual Channel Service

Now that you have created your source HTML file and saved it on your DNCS for your virtual channels, you are ready to set up your virtual channel service.

Use the following steps to set up virtual channels.

- 1 On the DNCS Administrative Console, click the **Server Applications** tab.
- 2 Click **VCS**. The VCS List window opens.

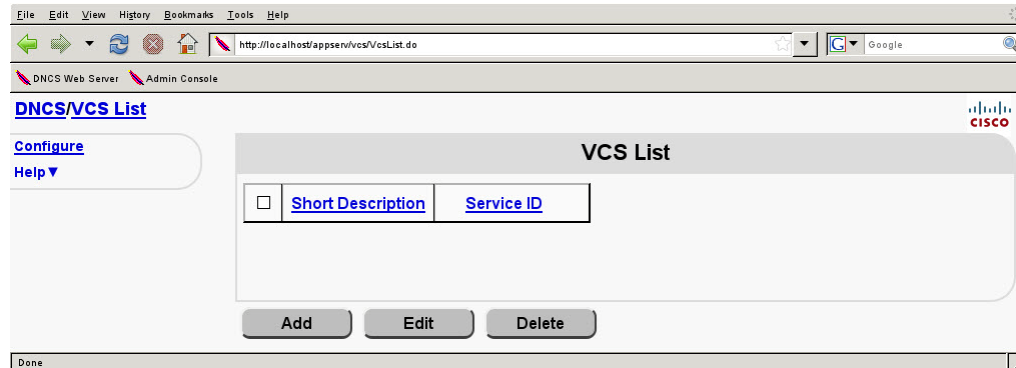

- 3 Click **Add**. The VCS window opens.

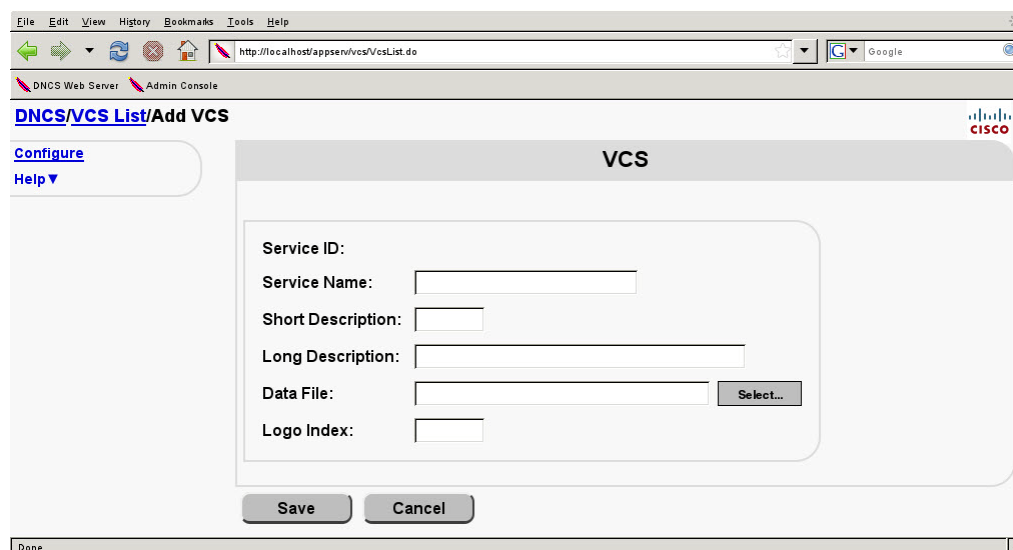

- 4 Type the service name, short description, and long description in their respective fields.
- 5 In the Data File field, click **Select**. A file selection window opens.  
**Note:** As part of setting up the virtual channel service, you must define the source that the service uses by linking the new service with an HTML file that you created earlier.
- 6 Browse to the directory and select the HTML file to display on the virtual channel.  
**Note:** The recommended place to save the html files is in /dvs/appFiles/html/good or in one of its subdirectories.
- 7 Click **OK** to return to the Set Up VCS window.
- 8 Type the logo index in the Logo Index field.
- 9 Click **Save**.

## Placing the Virtual Channel on the Channel Map

After you set up a virtual channel service, you must place the virtual channel on a channel map. Refer to the version of *Digital Network Control System Online Help (UNIX)* document that is written for your system release.

## Modifying a Virtual Channel Configuration

Use the following steps to modify a virtual channel configuration.

- 1 On the VCS List window, select the row of the desired service.
- 2 Click **Edit**.
- 3 Make desired changes on the Set Up VCS window, and click **Save**.

## Editing a Source File

The source files for virtual channels are links. As a result of editing, the source automatically forces the channel to update on the DHCTs.

Use the following steps to edit a source file.

- 1 Open the source file in the editor and make the changes you require.
- 2 Use the parse utility to verify your changes.
- 3 Check for updated information.

## Deleting a Virtual Channel

Use the following steps to delete a virtual channel.

- 1 Select the virtual channel you want to delete in the VCS List window.
- 2 Click **Delete**. A question prompts you to confirm that you want to delete the current item.
- 3 Click **Yes** to confirm that you want to delete the virtual channel.



# 8

## Enabling Power On Features

This chapter details the procedures used to manage the *Power On Keys*, *Numeric Keys Power On DHCT*, and *Power On Channel Selective Override* options.

**Note:** If the *Power On Keys* option is not selected, then the *Power On Keys* option is not displayed on the set-top box.

These options let you:

- Configure keys on the set-top remote control device to power-on the set-top from standby
- Change the power-on channel that is set for most subscribers without affecting subscribers who have chosen a different power-on channel for themselves

**Important:** The set-top remote control must be in "cable" mode for subscribers to use this feature to power-on the set-top from standby.

### In This Chapter

- Set Up Power On Keys..... 116
- Configure Power On Keys..... 117
- Configure Power On Channel Options ..... 121

## Set Up Power On Keys

Before AS 3.6, the *Numeric Keys Power On DHCT* option was an addressable staging configuration with two states:

- 1 The remote control Power Key must be pressed for the set-top to power on
- 2 The remote control Power Key or any Numeric Key must be pressed for the set-top to power on

Using AS 3.6 and later, the *Numeric Keys Power On DHCT* option is modified:

- *Numeric Keys Power On DHCT* can be configured as either a Global variable or as an Addressable variable
- Instead of a toggle button, the administrator selects power-on keys from the following combo list:
  - a Power Key Only
  - b Power and Numeric Keys
  - c Power, Numeric, Channel, and Volume Keys

**Note:** Channel keys include Channel +/-, LAST, and FAV. Volume keys include Vol +/- and Mute.

The screenshot shows a web browser window displaying the 'DNCS/DHCT Configure' interface. The main content area is titled 'Set Up Addressable DHCT Configuration'. At the top, there is a 'DHCT MAC Address' field and a 'Last Modified' timestamp of '09/15/2010 10:40:52 AM'. Below this, there are several tabs: 'Base Application', 'PIN Entry', 'General Settings', 'N/M Timers', 'Misc Settings', and 'IPG'. The 'Base Application' tab is selected, showing various configuration options. The 'Keys Power On DHCT' dropdown menu is set to 'Power Key Only'. Other options include 'AC Outlet Control' (Switched), 'Blocked Channel Number' (None), 'Block Programs Rated' (-add none-), 'Audio Language' (English), 'Screen Language' (English), 'Keyboard Language' (English), 'Color Scheme' (Town Square), 'LED Channel Switch' (Channel When Tuning), and 'Power On Channel' (Lowest Channel). There is also an 'Options' section with checkboxes for 'Clear All Blocked Channels', 'Clear All Favorites', 'VCR Commander', 'Clear All Blocked Ratings', 'Enable Auto Diagnostics', 'Enable DVD Auto-Play', 'Clear All Blocked Times', and 'ByPass When Off'. At the bottom, there are buttons for 'Send', 'Clear', 'Reset', and 'Cancel'.

## Configure Power On Keys

The Power On Keys feature can be configured globally (for all set-tops) or addressably (for certain set-tops).

In Global Configuration, the **Power On Keys** checkbox on the General Settings tab determines whether the Power On Keys feature is set for Addressable or for Global configuration.

- When checked, the **Power On Keys** checkbox enables **Addressable** configuration
- When unchecked, the **Power On Keys** checkbox enables **Global** configuration

The screenshot shows the Cisco DNCS/DHCT Configure interface. The main window is titled "Set Up Global DHCT Configuration". The "Name" field is set to "global" and the "Last Modified" timestamp is "12/13/2011 05:10:49 AM". The "General Settings" tab is selected, and the "VCR Commander Menu Option" is set to "Global". Under "User Menu Options", the "Power On Keys" checkbox is highlighted with a red box. Other options include "AC Outlet Control", "Audio: Digital Output", "Audio: Range", "Audio: Volume Control", "Block: Rating", "Block: Time", "VCR Commander", "Bypass When Off", "Display: Power Off", "Language: Audio", "Language: Screen", "Language: Keyboard", "LED Channel Switch", "Power On Channel", "RF Output Channel", "Set: Color Scheme", "Timer: All", "DVS Support", "Numeric Key Chooses Channel", and "Numeric Key Sets Times".

## Global Configuration

The Global configuration affects all the set-tops in the network.

- Keys that can power-on the set-top from standby are set from the Application Server.
- The Power On Keys option is not displayed in General Settings on the set-top box.

If **Power On Keys** is a Global Configuration, the **Keys Power On DHCT** combo list appears in the Base Application section of the Global configuration (see illustration below) and does **not** appear in the Base Application of Addressable and Staging Configuration.

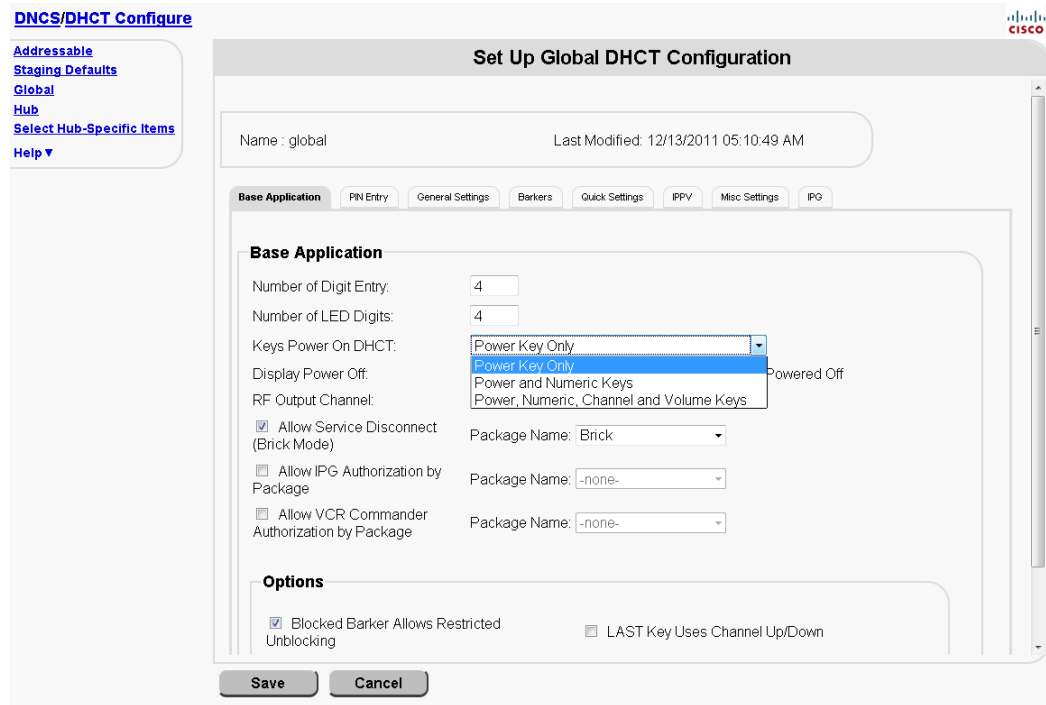

## Changing from Addressable to Global Configuration

If **Power On Keys** is configured as **Addressable**, it can later be changed to a Global configuration.

- 1 From Set Up Global DHCT Configuration in the General Settings tab, ensure the Power On Keys feature is unchecked. This enables the Global configuration.
- 2 The Power On Keys option is no longer displayed in the General Settings menu on each set-top box.

**Note:** Until the Global configuration is reconfigured from the server, the Addressable configuration value will be used. After the server is reconfigured and the Global configuration is set, it will override any Addressable configurations.

## Addressable Configuration

The Addressable configuration affects individual set-tops. Keys that will power on the set-top from standby can be set from the set-top General Setting menu.

**Note:** If the Global configuration is set, it will override any Addressable configurations.

If **Power On Keys** is an **Addressable** and Staging Configuration, the **Keys Power On DHCT** combo list appears in the Base Application of Addressable and Staging Configuration (see illustration below) and does **not** appear in the Base application of Global configuration.

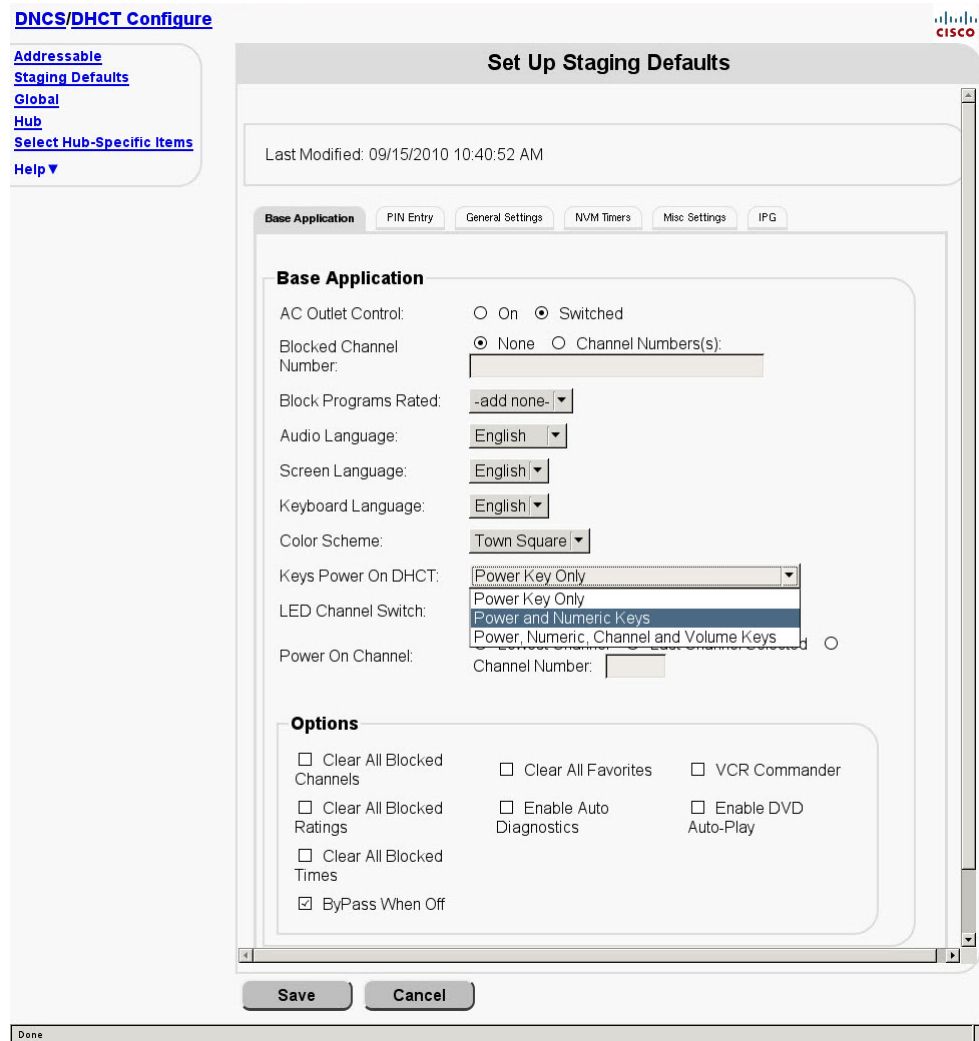

## Changing from Global to Addressable Configuration

If **Power On Keys** is configured as **Global**, it can later be changed to an Addressable configuration.

- 1 From the Global/General Settings tab, ensure the Power On Keys feature is checked. This enables the Addressable configuration.
- 2 The Power On Keys option is now displayed in the General Settings menu on each set-top box.

**Note:** The original, Global configuration value will be used until the Power On Keys option in General Settings is reconfigured from each set-top box.

## Upgrade to AS 3.6

**Important:** If you are upgrading from a version earlier than AS 3.6, be aware of the following:

- The existing value of **Numeric Keys Power On DHCT** (this includes Power Key Only, Power and Numeric Keys) is retained as the staging parameter value.
- The existing Addressable/Staging->Base Application->**Numeric Keys Power On DHCT** toggle button has been changed to a **Keys Power On DHCT** Combo List.
- The **Power On Keys** option is enabled and set to Addressable (**not** Global) by default.

## Configure Power On Channel Options

Some service providers set all of their set-tops to tune to a specific channel (often channel 2) whenever the set-top box is powered on. Other service providers allow their subscribers to choose the channel that they want to see when the set-top box is powered on. These settings are controlled through the Set Up DHCT Configuration window, on the Base Application tab and the General Settings tab.

In SR 4.4.1, you can change the power-on channel that is set for most of your subscribers *without* affecting the subscribers who have chosen a different power-on channel for themselves.

### Configuring Power On Channel Options Globally

Follow these steps to configure the power-on channel feature globally:

- 1 On the DNCS Administrative Console, select the **Server Applications** tab.
- 2 Click **DHCT Config**. The DHCT Configure window opens.
- 3 Click **Global**. The Set Up Global DHCT Configuration window opens.
- 4 Click the **General Settings** tab.
- 5 Clear the checkbox beside **Power On Channel**.

**Important:** Do *not* click Save yet. Once you click Save, your subscribers can no longer specify a power-on channel from the set-top menu. To minimize this disruption, follow these steps as written.

The screenshot shows the 'Set Up Global DHCT Configuration' window with the 'General Settings' tab selected. The 'VCR Commander Menu Option' is set to 'Global'. Under 'User Menu Options', the 'Power On Channel' checkbox is checked and highlighted with a red box. Other options include 'AC Outlet Control', 'Audio: Digital Output', 'Audio: Range', 'Audio: Volume Control', 'Block: Rating', 'Block: Time', 'Bypass When Off', 'Display: Power Off', 'Language: Audio', 'Language: Screen', 'Language: Keyboard', 'LED Channel Switch', 'RF Output Channel', 'Set: Color Scheme', 'Timer: All', 'DVS Support', and 'Power On Keys'. The 'Options' section includes 'Numeric Key Chooses Channel' and 'Numeric Key Sets Times'. The 'Save' and 'Cancel' buttons are at the bottom.

6 Click the **Base Application** tab.

The screenshot shows the 'Set Up Global DHCT Configuration' window with the following settings:

- Number of Digit Entry: 4
- Number of LED Digits: 4
- Keys Power On DHCT: Power Key Only
- Display Power Off:  Time When Powered Off  Blank When Powered Off
- Power On Channel:  Lowest Channel  Last Channel Selected  Channel Number:
- RF Output Channel:  3  4
- Allow Service Disconnect (Brick Mode) Package Name: Brick
- Allow IPG Authorization by Package Package Name: -none-
- Allow VCR Commander Authorization by Package Package Name: -none-

**Options**

- Blocked Barker Allows Restricted Unblocking
- Skip Unauthorized Channels
- LAST Key Uses Channel Up/Down
- Invalid Numeric Entry Chooses Next Highest Channel
- Power On Channel Selective Override

- 7 Select the checkbox beside **Power On Channel Selective Override**. This setting allows you to send power-on channel updates to most of your subscribers without affecting subscribers who have chosen their own power-on channel.
- 8 Use the Power On Channel fields on the Base Applications tab to set the default power-on channel.
- 9 Click **Save**. At the bottom of the screen, "DHCT Configuration successfully saved" will confirm the new setting.
- 10 Click the **General Settings** tab again, and re-select the checkbox beside **Power On Channel**.
- 11 Click **Save**. At the bottom of the screen, "DHCT Configuration successfully saved" will confirm the new setting.
- 12 Click **Cancel** to close the Set Up Global DHCT Configuration window.

## Configuring Power On Channel Selective By Hub

If necessary, you can also configure the power-on channel and the power-on channel selective override features differently for individual hubs.

In order to configure the power-on channel options by hub, you must first be sure that the global configuration is cleared. Otherwise, the power-on channel options will not appear on the Hub configuration window.

Follow these steps to configure the power-on channel selective override feature for a specific hub.

- 1 On the DNCS Administrative Console, select the **Server Applications** tab.

- 2 Click **DHCT Config**. The DHCT Configure window opens.
- 3 Click **Global**. The Set Up Global DHCT Configuration window opens.
- 4 Click the **General Settings** tab.
- 5 Clear the checkbox beside **Power On Channel**.

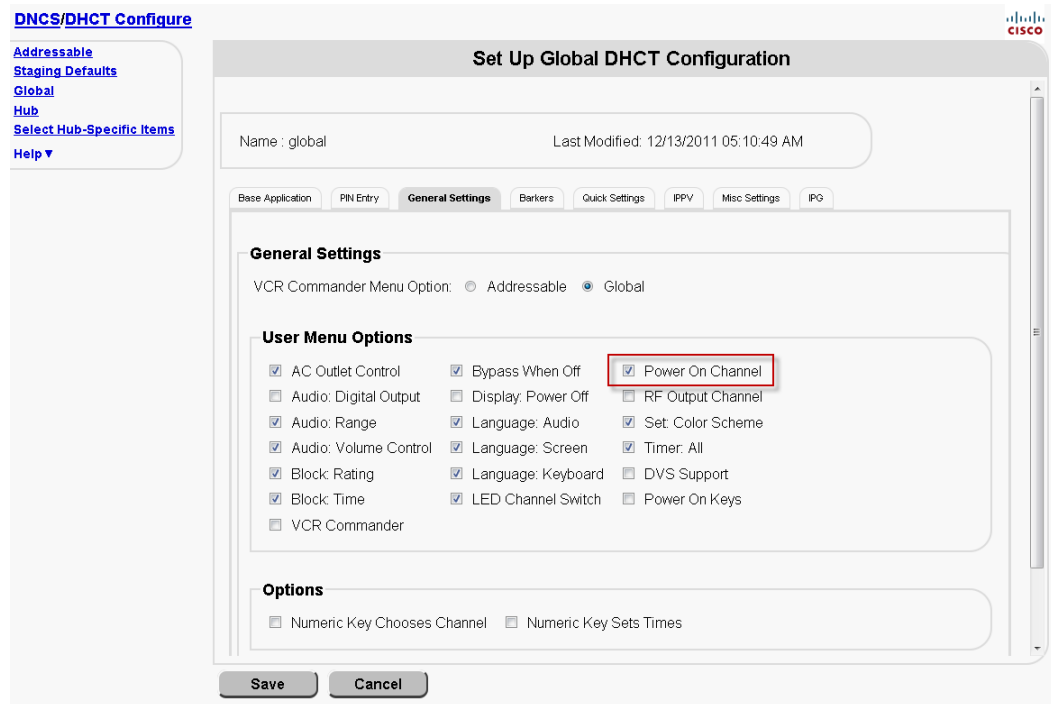

- 6 Click **Save** to apply the changes, then click **Cancel** to close the window.
- 7 In the DHCT Configure window, click **Hub**. The Hub List window expands to show a list of your hubs.

- 8 Click **Select Hub-Specific Items**. The Select Hub-Specific Items window opens.

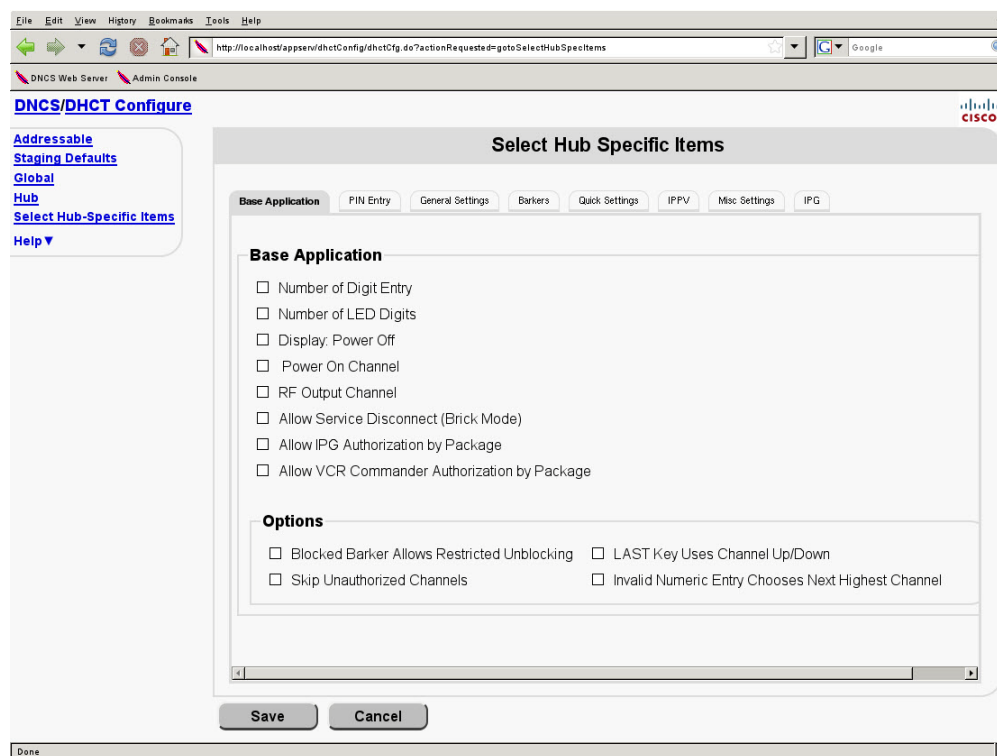

- 9 Click the **Base Application** tab.
- 10 Select the checkbox beside **Power On Channel**. This setting allows you to configure the power-on channel options for a specific hub.
- 11 Click **Save** to apply the changes and close the window.
- 12 In the DHCT Configure window, click to select the hub that you want to configure.
- 13 Does the table indicate that the configuration for that hub is hub-specific?
  - If **yes**, click the **File** menu and select **New Hub-Specific**. The Set Up Hub DHCT Configuration window opens.

- If **no**, click the **File** menu and select **Open**. The Set Up Hub DHCT Configuration window opens.

- 14 Click the **Base Application** tab.
- 15 Select the checkbox beside **Power On Channel Selective Override**.
- 16 Use the Power On Channel fields to set the default power-on channel.
- 17 Click **Save** to apply your changes, and click **Cancel** to close the window.
- 18 Do you want to allow subscribers to change their power-on channel options from the set-top box?
  - If **yes**, go to step 19.
  - If **no**, then you are finished with this procedure.
- 19 From the DHCT Configure window, click **Global**. The Set Up Global DHCT Configuration window opens.
- 20 Click the **General Settings** tab.
- 21 Clear the checkbox beside **Power On Channel**.
- 22 Click **Save** to apply the changes, then click **Cancel** to close the window.



# 9

---

## Enabling the Enhance Purchase PIN Feature

This chapter provides procedures such that an operator can enable or disable the Purchase PIN feature from the headend.

### In This Chapter

- Configure Purchase PIN ..... 128

## Configure Purchase PIN

The Purchase PIN feature on the set-top is set to **enabled** by default; for this reason, the Purchase PIN screen displays by default. Some customers prefer that an operator be able to enable or disable this feature from the headend, so these new procedures facilitate remote access and control of the Purchase PIN.

The operator can enable or disable the set-top resident Purchase PIN feature globally from the Set Up Global DHCT Configuration screen. The **Enable Enhance Purchase PIN** checkbox on the Global/PIN Entry tab determines the state of the Purchase PIN feature.

- When checked, the Purchase PIN feature is enabled
- When unchecked, the Purchase PIN feature is disabled

The screenshot displays the 'Set Up Global DHCT Configuration' web interface. On the left, a navigation menu includes 'DNCS/DHCT Configure', 'Addressable', 'Staging Defaults', 'Global', 'Hub', 'Select Hub-Specific Items', and 'Help'. The main content area is titled 'Set Up Global DHCT Configuration' and shows the 'PIN Entry' tab selected. The 'Name' field is set to 'global' and the 'Last Modified' timestamp is '12/13/2011 05:10:49 AM'. Below this, there are tabs for 'Base Application', 'PIN Entry', 'General Settings', 'Barkers', 'Quick Settings', 'IPV', 'Misc Settings', and 'IPG'. The 'PIN Call Number' is entered as '(800)555-1212'. The 'Blocking PIN' section includes 'Lockout Time' (5 minutes), 'Trial Timer' (3 minutes), 'Invalid Tries' (5), and an unchecked checkbox for 'Enable Blocking PIN Lockout'. The 'Purchase PIN' section includes 'Lockout Time' (5 minutes), 'Trial Timer' (3 minutes), 'Invalid Tries' (5), and two checkboxes: 'Enable Purchase PIN Lockout' (unchecked) and 'Enable Enhance Purchase PIN' (checked). At the bottom, there are 'Save' and 'Cancel' buttons.

# 10

---

## Enabling Tracing on the Application Server

The Application Server can track the flow of data messages between the Application Server and other network elements and store those messages in a log file. The process of tracking those data messages is called tracing.

This chapter provides procedures to enable and disable the tracing function and to specify the level of detail that you want to include in the log file.

### In This Chapter

- Enabling Logging..... 130
- View the Log Files ..... 131

## Enabling Logging

**Important:** If you set your logging levels too high, you could raise your Application Server load levels to unacceptable levels. You should only adjust these logging levels if you are troubleshooting a specific problem.

### Using the applogLvl Utility

You can use the applogLvl utility to view and change logging levels from a command line on the Application Server as dnscs user in order to support troubleshooting activities. Execute these commands from the /dvs/appserv/bin directory.

The following commands are available:

Command	Result
<b>applogLvl</b>	Displays the current logging level for all processes.
<pre>/export/home/dnscs&gt;applogLvl appUIServer    +EM +AL +CR +ER +WA -NO -IN -DE -PE -PI -ZIP HCT            +EM +AL +CR +ER +WA -NO -IN -DE -PE -PI -ZIP ipgServerEng   +EM +AL +CR +ER +WA -NO -IN -DE -PE -PI -ZIP . . .</pre>	
<b>applogLvl &lt;processname&gt;</b>	Displays the current logging level for the specified process.
<pre>/export/home/dnscs&gt;applogLvl ppvServer ppvServer      +EM +AL +CR +ER +WA -NO -IN -DE -PE -PI -ZIP</pre>	
<b>applogLvl &lt;processname&gt; +&lt;level&gt;</b>	Turns on a logging level for the specified process.
<pre>/export/home/dnscs&gt;applogLvl ppvServer +NO ppvServer      +EM +AL +CR +ER +WA +NO -IN -DE -PE -PI -ZIP</pre>	
<b>applogLvl &lt;processname&gt; -&lt;level&gt;</b>	Turns off a logging level for the specified process.
<pre>/export/home/dnscs&gt;applogLvl ppvServer -NO ppvServer      +EM +AL +CR +ER +WA -NO -IN -DE -PE -PI -ZIP</pre>	
<b>applogLvl -h</b>	Provides a help output for the applogLvl utility.

## View the Log Files

The Application Server captures various kinds of trace information to various log files. Those log files are stored in two directories: `/var/log/dnclsLog` and `/dvs/appserv/tmp`.

- The files in `/var/log/dnclsLog` only contain error messages and process start/stop messages. The Application Server automatically deletes these log files after three days.
- The files in `/dvs/appserv/tmp` contain all of the process output that is captured. The Application Server automatically deletes these log files after seven days.

## The Logger Utility

The Application Server includes a utility called Logger that manages the size, name, and placement of the log files in the `/dvs/appserv/tmp` directory.

Logger creates a new log file for each traced process every day or when the previous log file reaches a pre-determined size; these log files are stored for seven days.

When Logger creates a new log file, it closes and compresses the old file using the gzip utility, which renames the compressed file to include a `.gz` extension.

## Viewing the Log File

To view the data in a zipped log file, type **gunzip goqam.gz** and press **Enter**. In this command, `goqam` is the name of the file you want to view. When you enter this command, the Application Server creates an unzipped file without the `.gz` extension.

For example, to view the data in `vcServer.101.gz`, type **gunzip vcServer.101.gz** and press **Enter**. The Application Server creates an unzipped file called `vcServer.101`.

## Log File Naming Conventions

Log files for individual processes are stored in the `/dvs/appserv/tmp` directory. The file name of the log for an individual process is the name of the process followed by a 3-digit counter. For example, the file name for the `ppvServer` log might be `ppvServer.000`. After this log file reaches the maximum size, a new file called `ppvServer.001` will be created.



# 11

---

## Customer Information

### If You Have Questions

If you have technical questions, call Cisco Services for assistance. Follow the menu options to speak with a service engineer.

Access your company's extranet site to view or order additional technical publications. For accessing instructions, contact the representative who handles your account. Check your extranet site often as the information is updated frequently.



Cisco Systems, Inc.  
5030 Sugarloaf Parkway, Box 465447  
Lawrenceville, GA 30042

678 277-1120  
800 722-2009  
[www.cisco.com](http://www.cisco.com)

This document includes various trademarks of Cisco Systems, Inc. Please see the Notices section of this document for a list of the Cisco Systems, Inc. trademarks used in this document.

Product and service availability are subject to change without notice.

© 2012 Cisco Systems, Inc. All rights reserved.

February 2012 Printed in United States of America

Part Number 4038960 Rev A