



Installation Instructions

Compact Amplifier Type 93212

Application

The Compact amplifier 93212 has one active output and is used in trunk and distribution applications. The amplifier can be monitored via the Compact Transponder and Element Management System.

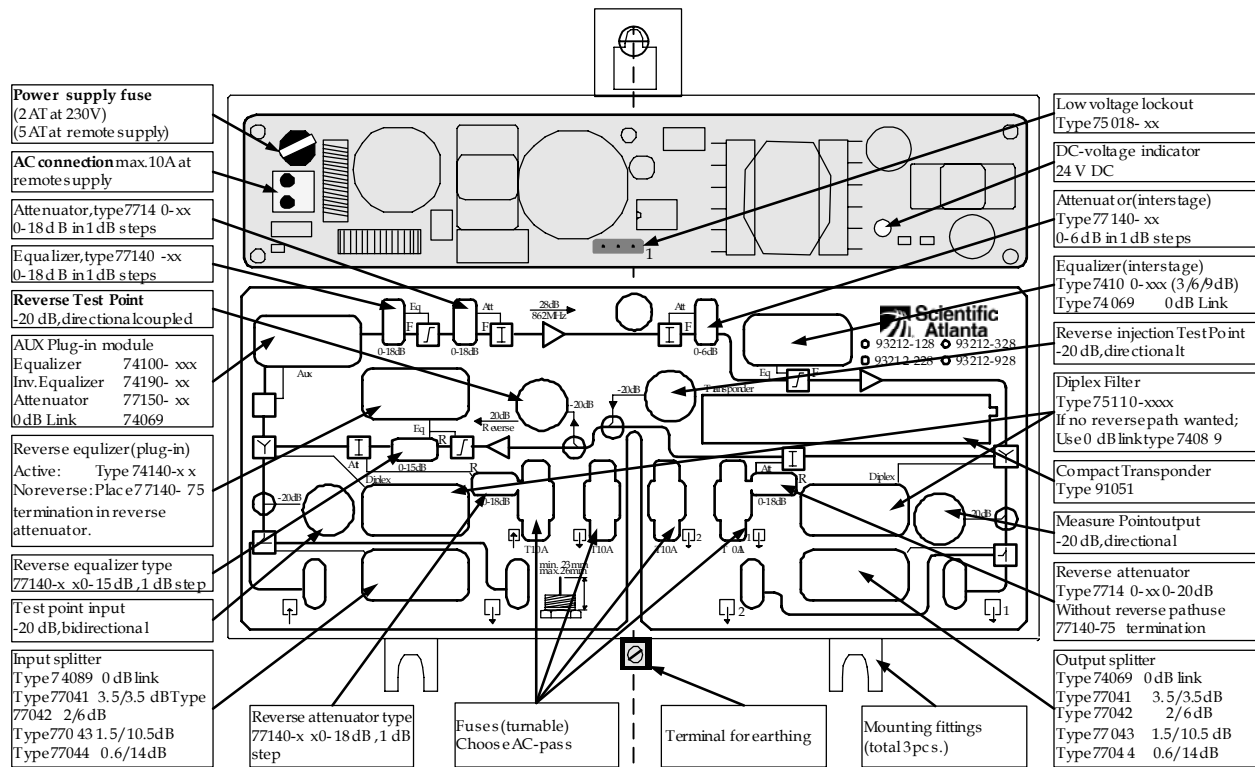

Instructions

Mounting

The amplifier is mounted perpendicularly with the cable inlet at the bottom in order to secure natural ventilation during operation. Use a 5 mm Allen key for screw in lid and fasten with 5 Nm. The distance between the mounting flanges is illustrated above and marked with three circles (⊕).

Plug-in units

Input splitter

Link type 74089 is applied if the loop port is not used. Splitters with bridger provide the largest attenuation at the amplifier input.

Output splitter

If an asymmetric splitter (bridger) is used, the largest attenuation at the output 2 (OUT 2) is obtained. If only a signal at output 1 (OUT 1) is requested, link type 74069 is used.

Diplex reverse filters

Two diplex reverse filters type 75110 with the requested filter frequency are used. If the reverse path is not used, two links 74089 are mounted.

AUX plug-in field (equalizer, attenuator)

In order to adjust the amplifiers to the cable, it may be necessary to insert an equalizer type 74100-xxx at the input. If no equalization/attenuation is requested, insert 0 dB link type 74069.

Input Equalizer and Attenuator 3-pin

Use 77140-xx (0-18dB in 1 dB step) to select attenuation and equalizing at the input.

Interstage

Interstage equalizer

The amplifier can be adjusted without an equalizer because of the automatic 0 dB link. The equalizer is mounted and the output level has now been pre-equalized.

Interstage attenuator

The gain can be adjusted with an interstage attenuator (1 to 6 dB) in order to minimize the influence on the system values.

Instructions

Reverse path

With active reverse path, an equalizer type 74140-xx is placed in the plug-in field for reverse path equalizer. Please note the test point and signal injection point of the reverse path are referring to the input of the reverse path.

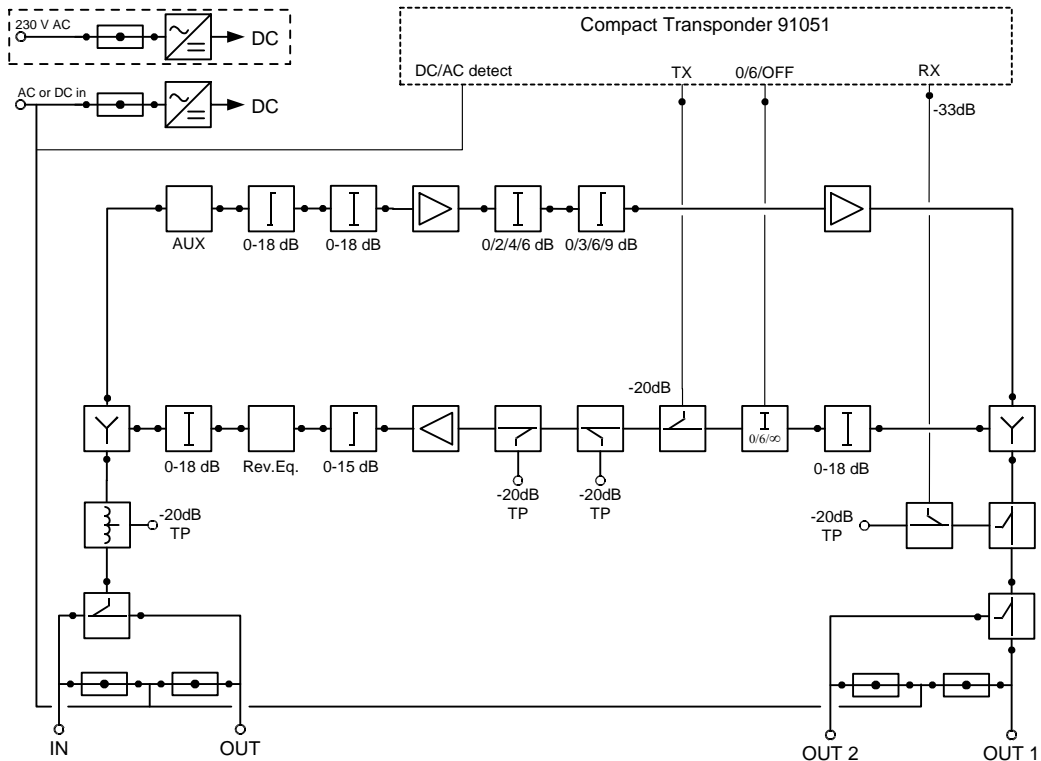

Output Equalizer and Attenuator 3-pin

Use 77140-xx (0-18dB in 1 dB step) to select attenuation and use 77140-xx (0-15dB in 1 dB step) to select equalizing at the output.

If the reverse path transmission is not used, a termination type 77140-75 is mounted in the reverse path output attenuation plug-in field.

Input Attenuator 3-pin

In order to add further attenuation in the reverse path, an attenuator type 77140-xx (0-20 dB in 1 dB step) is mounted in the plug-in field. If no attenuation is requested, 77140-00 is mounted and if a termination of the reverse path is requested, 77140-75 is mounted (only necessary if diplex filters have been mounted).

Instructions

Compact Transponder type 91051

With this transponder it is possible to monitor the amplifier output level, temperature and power supply. Furthermore the built-in reverse path switch can be controlled.

Power supply

Power supply 115 V AC or 230 V AC

The amplifier is delivered with mounted network cable and network plug. It is not legitimate to make alterations. The power supply is double isolated and supplies only this amplifier. When the DC voltage indicator in the switch mode power supply lights, the amplifier is supplied with the correct DC voltage from the power supply.

Remote supply 24-65 V AC (or 35-90 V AC)

The amplifier is supplied with 24-65 V AC either via a coaxial cable (max. 7 A) or directly at the AC input (max. 10A). On delivery, the ports are equipped with isolation fuses.

Permanent exceeding of the maximum remote supply current implies risk of damage.

Undervoltage lock out

For all remote supplied power supplies an undervoltage lock out type 75018 can be obtained that switches off the power supply if the voltage drops below the rated value, thus damages in the network due to the increased power consumption can be avoided.

Accessories

Fuse 5 AT	A38011	F-test adapter	A71004
Fuse 10 AT	A38016	Fuse 2 AT	A38008

For Information

If You Have Questions

Region	Centers	Customer Service Numbers
North America	USA	■ Toll-free: 1-800-722-2009
Europe, Middle East, Africa	Belgium	■ Telephone: 32-56-445-133 or 32-56-445-118
Japan	Japan	■ Telephone: 81-3-5908-2153 or +81-3-5908-2154
Korea	Korea	■ Telephone: 82-2-6205-6004
China (mainland)	China	■ Telephone: 86-21-6237-5233
Other Asia-Pacific countries, Australia	Hong Kong	■ Telephone: 852-2522-5059
Brazil	Brazil	■ Telephone: 55-11-3845-9154, ext 109
Mexico, Central America, Caribbean	Mexico	■ Telephone: 52-55-50-81-8425
All other Latin America countries	Argentina	■ Telephone: 770-236-5662



5030 Sugarloaf Parkway, Box 465447
Lawrenceville, GA 30042

678.277.1000

Cisco, Cisco Systems, the Cisco logo, the Cisco Systems logo, Scientific Atlanta, and SciCare are registered trademarks or trademarks of Cisco Systems, Inc. and/or its affiliates in the U.S. and certain other countries.

All other trademarks mentioned in this document are the property of their respective owners.
Product and service availability are subject to change without notice.

© 2008 Cisco Systems, Inc. All rights reserved.
December 2008

Printed in United States of America
Part Number 4006041 Rev C