



## Configuring UDLD

---

This chapter describes how to configure the UniDirectional Link Detection (UDLD) protocol in Release 12.1(2)E and later releases on the Catalyst 6500 series switches.



**Note**

---

For complete syntax and usage information for the commands used in this chapter, refer to the *Catalyst 6500 Series Switch Cisco IOS Command Reference* publication.

---

This chapter consists of these sections:

- [Understanding How UDLD Works, page 32-1](#)
- [Default UDLD Configuration, page 32-3](#)
- [Configuring UDLD, page 32-3](#)

## Understanding How UDLD Works

These sections describe how UDLD works:

- [UDLD Overview, page 32-1](#)
- [UDLD Aggressive Mode, page 32-2](#)

### UDLD Overview

The UDLD protocol allows devices connected through fiber-optic or copper (for example, Category 5 cabling) Ethernet cables connected to LAN ports to monitor the physical configuration of the cables and detect when a unidirectional link exists. When a unidirectional link is detected, UDLD shuts down the affected LAN port and alerts the user. Unidirectional links can cause a variety of problems, including spanning tree topology loops.

UDLD is a Layer 2 protocol that works with the Layer 1 protocols to determine the physical status of a link. At Layer 1, autonegotiation takes care of physical signaling and fault detection. UDLD performs tasks that autonegotiation cannot perform, such as detecting the identities of neighbors and shutting down misconnected LAN ports. When you enable both autonegotiation and UDLD, Layer 1 and Layer 2 detections work together to prevent physical and logical unidirectional connections and the malfunctioning of other protocols.

A unidirectional link occurs whenever traffic transmitted by the local device over a link is received by the neighbor but traffic transmitted from the neighbor is not received by the local device. If one of the fiber strands in a pair is disconnected, as long as autonegotiation is active, the link does not stay up. In this case, the logical link is undetermined, and UDLD does not take any action. If both fibers are working normally at Layer 1, then UDLD at Layer 2 determines whether those fibers are connected correctly and whether traffic is flowing bidirectionally between the correct neighbors. This check cannot be performed by autonegotiation, because autonegotiation operates at Layer 1.

The Catalyst 6500 series switch periodically transmits UDLD packets to neighbor devices on LAN ports with UDLD enabled. If the packets are echoed back within a specific time frame and they are lacking a specific acknowledgment (echo), the link is flagged as unidirectional and the LAN port is shut down. Devices on both ends of the link must support UDLD in order for the protocol to successfully identify and disable unidirectional links.

**Note**

By default, UDLD is locally disabled on copper LAN ports to avoid sending unnecessary control traffic on this type of media since it is often used for access ports.

Figure 32-1 shows an example of a unidirectional link condition. Switch B successfully receives traffic from Switch A on the port. However, Switch A does not receive traffic from Switch B on the same port. UDLD detects the problem and disables the port.

**Figure 32-1 Unidirectional Link**

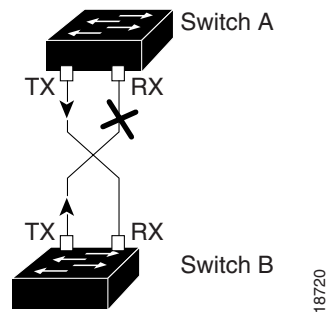

## UDLD Aggressive Mode

Release 12.1(3a)E and later releases support UDLD aggressive mode. UDLD aggressive mode is disabled by default. Configure UDLD aggressive mode only on point-to-point links between network devices that support UDLD aggressive mode. With UDLD aggressive mode enabled, when a port on a bidirectional link that has a UDLD neighbor relationship established stops receiving UDLD packets, UDLD tries to reestablish the connection with the neighbor. After eight failed retries, the port is disabled.

To prevent spanning tree loops, nonaggressive UDLD with the default interval of 15 seconds is fast enough to shut down a unidirectional link before a blocking port transitions to the forwarding state (with default spanning tree parameters).

When you enable UDLD aggressive mode, you receive additional benefits in the following situations:

- One side of a link has a port stuck (both Tx and Rx)
- One side of a link remains up while the other side of the link has gone down

In these cases, UDLD aggressive mode disables one of the ports on the link, which prevents traffic from being discarded.

**Note**

In UDLD normal mode, when a unidirectional error is detected, the port is not disabled. In UDLD aggressive mode, when a unidirectional error is detected, the port is disabled.

## Default UDLD Configuration

Table 32-1 shows the default UDLD configuration.

**Table 32-1 UDLD Default Configuration**

Feature	Default Value
UDLD global enable state	Globally disabled
UDLD aggressive mode	Disabled
UDLD per-port enable state for fiber-optic media	Enabled on all Ethernet fiber-optic LAN ports
UDLD per-port enable state for twisted-pair (copper) media	Disabled on all Ethernet 10/100 and 1000BASE-TX LAN ports

## Configuring UDLD

These sections describe how to configure UDLD:

- [Enabling UDLD Globally, page 32-3](#)
- [Enabling UDLD on Individual LAN Interfaces, page 32-4](#)
- [Disabling UDLD on Fiber-Optic LAN Interfaces, page 32-5](#)
- [Configuring the UDLD Probe Message Interval, page 32-5](#)
- [Resetting Disabled LAN Interfaces, page 32-6](#)

**Note**

With Release 12.1(11b)E and later releases, when you are in configuration mode you can enter EXEC mode-level commands by entering the **do** keyword before the EXEC mode-level command.

## Enabling UDLD Globally

To enable UDLD globally on all fiber-optic LAN ports, perform this task:

Command	Purpose
Router(config)# <b>udld</b> { <b>enable</b>   <b>aggressive</b> }	Enables UDLD globally on fiber-optic LAN ports.  <b>Note</b> This command only configures fiber-optic LAN ports. Individual LAN port configuration overrides the setting of this command.
Router(config)# <b>no udld</b> { <b>enable</b>   <b>aggressive</b> }	Disables UDLD globally on fiber-optic LAN ports.

## Enabling UDLD on Individual LAN Interfaces

With Release 12.1(13)E and later releases, to enable UDLD on individual LAN ports, perform this task:

	Command	Purpose
<b>Step 1</b>	Router(config)# <b>interface</b> <i>type</i> <sup>1</sup> <i>slot/port</i>	Selects the LAN port to configure.
<b>Step 2</b>	Router(config-if)# <b>udld port</b> [ <b>aggressive</b> ]  Router(config-if)# <b>no udld port</b> [ <b>aggressive</b> ]	Enables UDLD on a specific LAN port. Enter the <b>aggressive</b> keyword to enable aggressive mode. On a fiber-optic LAN port, this command overrides the <b>udld enable</b> global configuration command setting.  Disables UDLD on a nonfiber-optic LAN port.  <b>Note</b> On fiber-optic LAN ports, the <b>no udld port</b> command reverts the LAN port configuration to the <b>udld enable</b> global configuration command setting.
<b>Step 3</b>	Router# <b>show udld</b> <i>type</i> <sup>1</sup> <i>slot/number</i>	Verifies the configuration.

1. *type* = ethernet, fastethernet, gigabitethernet, or tengigabitethernet

With earlier releases, to enable UDLD on individual LAN ports, perform this task:

	Command	Purpose
<b>Step 1</b>	Router(config)# <b>interface</b> <i>type</i> <sup>1</sup> <i>slot/port</i>	Selects the LAN port to configure.
<b>Step 2</b>	Router(config-if)# <b>udld enable</b> [ <b>aggressive</b> ]  Router(config-if)# <b>no udld enable</b> [ <b>aggressive</b> ]	Enables UDLD on a specific LAN port. Enter the <b>aggressive</b> keyword to enable aggressive mode. On a fiber-optic LAN port, this command overrides the <b>udld enable</b> global configuration command setting.  Disables UDLD on a nonfiber-optic LAN port.  <b>Note</b> On fiber-optic LAN ports, the <b>no udld enable</b> command reverts the LAN port configuration to the <b>udld enable</b> global configuration command setting.
<b>Step 3</b>	Router# <b>show udld</b> <i>type</i> <sup>1</sup> <i>slot/number</i>	Verifies the configuration.

1. *type* = ethernet, fastethernet, gigabitethernet, or tengigabitethernet

## Disabling UDLD on Fiber-Optic LAN Interfaces

With Release 12.1(13)E and later releases, to disable UDLD on individual fiber-optic LAN ports, perform this task:

	Command	Purpose
<b>Step 1</b>	Router(config)# <b>interface</b> <i>type</i> <sup>1</sup> <i>slot/port</i>	Selects the LAN port to configure.
<b>Step 2</b>	Router(config-if)# <b>udld port disable</b> Router(config-if)# <b>no udld port disable</b>	Disables UDLD on a fiber-optic LAN port. Reverts to the <b>udld enable</b> global configuration command setting. <b>Note</b> This command is only supported on fiber-optic LAN ports.
<b>Step 3</b>	Router# <b>show udld</b> <i>type</i> <sup>1</sup> <i>slot/number</i>	Verifies the configuration.

1. *type* = ethernet, fastethernet, gigabitethernet, or tengigabitethernet

With earlier releases, to disable UDLD on individual fiber-optic LAN ports, perform this task:

	Command	Purpose
<b>Step 1</b>	Router(config)# <b>interface</b> <i>type</i> <sup>1</sup> <i>slot/port</i>	Selects the LAN port to configure.
<b>Step 2</b>	Router(config-if)# <b>udld disable</b> Router(config-if)# <b>no udld disable</b>	Disables UDLD on a fiber-optic LAN port. Reverts to the <b>udld enable</b> global configuration command setting. <b>Note</b> This command is only supported on fiber-optic LAN ports.
<b>Step 3</b>	Router# <b>show udld</b> <i>type</i> <sup>1</sup> <i>slot/number</i>	Verifies the configuration.

1. *type* = ethernet, fastethernet, gigabitethernet, or tengigabitethernet

## Configuring the UDLD Probe Message Interval

To configure the time between UDLD probe messages on ports that are in advertisement mode and are currently determined to be bidirectional, perform this task:

	Command	Purpose
<b>Step 1</b>	Router(config)# <b>udld message time</b> <i>interval</i>  Router(config)# <b>no udld message</b>	Configures the time between UDLD probe messages on ports that are in advertisement mode and are currently determined to be bidirectional; valid values are from 7 to 90 seconds. Returns to the default value (60 seconds).
<b>Step 2</b>	Router# <b>show udld</b> <i>type</i> <sup>1</sup> <i>slot/number</i>	Verifies the configuration.

## Resetting Disabled LAN Interfaces

To reset all LAN ports that have been shut down by UDLD, perform this task:

Command	Purpose
Router# <code>udld reset</code>	Resets all LAN ports that have been shut down by UDLD.