



Configuring ATM LAN Emulation

This chapter describes how to configure ATM LAN Emulation (LANE) on the ATM modules for the Catalyst 5000 and 6000 family switches.



Note

For information on installing Catalyst 5000 family ATM modules, refer to the *Catalyst 5000 Family Module Installation Guide*. For information on installing Catalyst 6000 family ATM modules, refer to the *Catalyst 6000 Family Module Installation Guide*.



Note

For syntax and usage information for the commands used in this chapter, see the Chapter 7, “Command Reference.”

This chapter consists of these sections:

- Understanding How ATM LANE Works, page 3-1
- Default ATM LANE Configuration, page 3-9
- ATM LANE Configuration Guidelines, page 3-9
- Configuring ATM LANE, page 3-11
- Configuring Fast SSRP for Redundant LANE Services, page 3-24
- Creating LECs Automatically Using VTP, page 3-29
- ATM LANE Configuration Examples, page 3-31
- Understanding LANE QoS, page 3-43
- Configuring LANE QoS, page 3-44

Understanding How ATM LANE Works

These sections describe how ATM LANE works on the Catalyst 5000 family switches:

- ATM LANE Overview, page 3-2
- ATM LANE Components, page 3-3
- Comparing VLANs and ELANs, page 3-4
- LANE Operation and Communication Connections, page 3-4
- Joining a LEC to an ELAN, page 3-5

- ELAN Address Resolution, page 3-6
- Sending Multicast Traffic, page 3-6
- LANE ATM Addressing Structure, page 3-7
- Assigning ATM Addresses Automatically, page 3-7
- Registering ILMI Addresses, page 3-8
- Using VTP to Create LECs Automatically, page 3-8
- Drafting an ATM LANE Implementation Plan, page 3-8

ATM LANE Overview

ATM LANE uses a client server architecture to emulate LANs over ATM. But unlike a physical LAN server/host architecture, emulated LANs are logical. You use LANE to provide connectivity among hubs, bridges, routers, and switches to an ATM high-speed backbone. In addition, LANE allows end stations to communicate with an ATM-attached device, such as a file server, through a LAN-to-ATM switch without requiring the traffic to pass through a router.

Configuring LANE on a Catalyst 5000 or 6000 family LANE module requires connectivity to an ATM switch that supports User-Network Interface (UNI) 3.0 or 3.1 and point-to-multipoint signaling (for example, the Cisco LightStream 1010 ATM switch).



Note

Cisco supports only IEEE 802.3, Ethernet emulated LANs (ELANs).

LANE provides the following features:

- Connectivity between ATM-attached stations and LAN-attached stations
- Connectivity between LAN-attached stations across an ATM network

Because LANE connectivity is defined at the Media Access Control (MAC) layer, upper-layer protocol functions of LAN applications can operate unchanged when the devices join ELANs. This feature protects corporate investments in legacy LAN applications.

An ATM network can support multiple independent ELANs. End-system membership in any of the ELANs is independent of the physical location of the end system, simplifying hardware adds, moves, and changes. In addition, the end systems can move easily from one ELAN to another, whether or not the hardware moves. Figure 3-1 shows a typical ATM LANE configuration. End stations in switched LANs are interconnected through an ATM network with ELANs that have been mapped to existing VLANs on the switched LANs. VLANs can be extended across the ATM backbone by mapping them to configured ELANs.



Note

Figure 3-1 shows VLANs connected through ELANs configured on a router. You do not need to route traffic between hosts on the same VLANs or ELANs. To enable traffic between hosts on different VLANs or ELANs, the router needs to be configured for LANE.

Figure 3-1 Extending VLANs Using ATM LANE

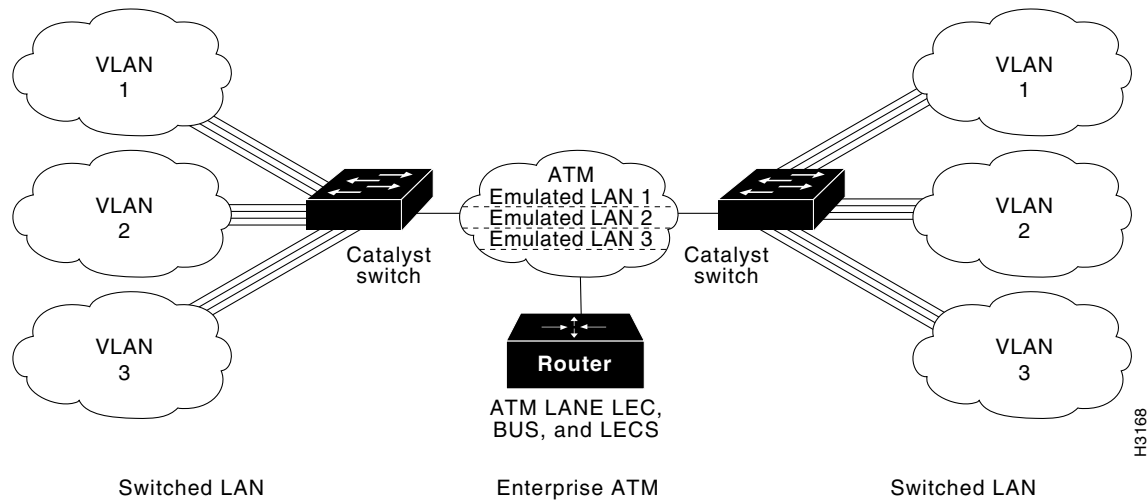

ATM LANE Components

You can set up an unlimited number of ELANs in an ATM cloud. A Catalyst 5000 or 6000 family switch ATM module can host multiple ELANs. If you use the Fast Simple Server Redundancy Protocol (FSSRP), each ELAN can contain multiple LES/BUS pairs for fault tolerance.

LANE is defined on a client-server LAN model and consists of these components:

- **LANE Client (LEC)**—A LEC emulates a LAN interface to higher-layer protocols and applications. LECs forward data to other LANE components and perform LANE address-resolution functions. Each LEC is a member of only one ELAN. Traffic must be routed between LECs that belong to different ELANs.
- **LANE Server (LES)**—The LES for an ELAN is the control center. It provides joining, address resolution, and address registration services to the LECs in that ELAN. LECs can register destination unicast and multicast MAC addresses with the LES. In addition, the LES handles LANE Address Resolution Protocol (LE ARP) requests and responses.
- **LANE broadcast-and-unknown server (BUS)**—The LANE BUS sequences and distributes multicast and broadcast packets and handles unicast flooding. At least one combined LES and BUS is required per ELAN.
- **LANE Configuration Server (LECS)**—The LECS contains a database of ATM addresses of LES/BUS pairs for configured ELANs. A LEC consults the LECS to determine the LES's ATM address when it first joins an ELAN. The LECS returns the ATM address of the LES for that ELAN.

At least one LECS is required per ATM LANE switch cloud.

The LECS database can have the following four types of entries:

- ELAN_name, ATM_address_of_LES/BUS pairs
- LEC_MAC_address, ELAN_name pairs
- LEC_ATM_template, ELAN_name pairs
- Default_ELAN_name

ELAN names must be unique on an interface. If two interfaces participate in LANE, the second interface might be in a different switch cloud.

**Note**

Multiple LESs, BUSs, and LECSs can exist for the same ELAN, which provides redundancy. See the “Configuring Fast SSRP for Redundant LANE Services” section on page 3-24 for information on how to configure server redundancy.

Comparing VLANs and ELANs

Catalyst 5000 and 6000 family switches support port-based VLAN configuration. An end station connected to a port belongs to the VLAN assigned to that port. The VLAN number identifies the VLAN.

On an ATM network, ELANs are designated by a name. You can configure some ELANs from a router and some from a Catalyst 5000 or 6000 family switch. You can configure some ELANs with unrestricted membership and some with restricted membership. You can also configure a default ELAN, which must have unrestricted membership.

To create a VLAN that spans multiple Catalyst LAN switches across an ATM network, you must map a given ATM ELAN to the same VLAN configured on each switch. For example, if you have VLAN 10 configured on two different switches, you must map VLAN 10 to the same ATM ELAN. To communicate between two or more ELANs, you must use a router, whether the ELANs are on the same or different Catalyst switches.

LANE Operation and Communication Connections

Establishing LANE operation and communication requires the following connections:

- **Configure-Direct Connection**—Bidirectional point-to-point virtual circuit connection (VCC) established by the LEC to the LECS.
- **Control-Direct Connection**—Bidirectional point-to-point VCC set up by the LEC to register with the LES. This connection is used later by the LEC to transmit LE-ARP requests for ATM addresses of the BUS and other LECs.
- **Control-Distribute Connection**—Unidirectional point-to-point VCC established by the LES to the LEC to verify registration.
- **Multicast-Send Connection**—Bidirectional point-to-point VCC set up by the LEC to the BUS.
- **Multicast-Forward Connection**—Bidirectional or unidirectional connection VCC set up by the BUS to distribute data to the LEC.
- **Data-Direct Connection**—Bidirectional point-to-point VCC set up between LECs for unicast traffic.

Figure 3-2 illustrates the various types of VCCs.

Figure 3-2 LANE Virtual Channel Circuit Types

Joining a LEC to an ELAN

The following process (illustrated in Figure 3-2) occurs after you enable a LEC on the ATM module in a Catalyst 5000 or 6000 family switch:

1. Initialization
 - a. Using a locally configured ATM address, ILMI, or the ATM Forum's well-known address, the LEC discovers its own ATM address and that of the LECS and sets up a Configure-Direct Connection (a bidirectional point-to-point VCC) to the LECS.
 - b. The LECS responds by providing the LES ATM address.
 - c. The LEC tears down the Configure-Direct VCC.
2. Registration
 - a. The LEC sets up a Control-Direct Connection to the LES and requests to join the ELAN.
 - b. The LES verifies that the LEC is allowed to join the ELAN.
 - c. The LES for the ELAN sets up a connection to the LECS to verify that the LEC is allowed to join the ELAN (bidirectional, point-to-point Server Configure VCC, link 11–12 in Figure 3-2). The LES configuration request contains the LEC MAC address, its ATM address, and the name of the ELAN. The LECS checks its database to determine whether the LEC can join that ELAN and uses the same VCC to inform the LES whether or not the LEC is allowed to join.
 - d. The LES allows or does not allow the LEC to join the ELAN.
 - e. If allowed, the LES adds the LEC to the unidirectional, point-to-multipoint Control Distribute VCC (link 2–8 in Figure 3-2) and confirms the LEC's membership over the bidirectional, point-to-point Control Direct VCC (link 1–7 in Figure 3-2). If not allowed, the LES rejects the LEC's request to join using the bidirectional, point-to-point Control Direct VCC (link 1–7 in Figure 3-2).
 - f. The LEC sends LE ARP packets for the broadcast address (all ones).

- g. Sending LE ARP packets for the broadcast address returns the ATM address of the BUS. The LEC sets up the Multicast Send VCC (link 4–9 in Figure 3-2), and the BUS adds the LEC to the Multicast Forward VCC (link 5–10 in Figure 3-2) to and from the BUS.

ELAN Address Resolution

As communication occurs on the ELAN, each LEC dynamically builds a local LE ARP table. A LEC LE ARP table can also have static, preconfigured entries. The LE ARP table maps MAC addresses to ATM addresses.

LE ARP is not the same as IP ARP. IP ARP maps IP addresses (Layer 3) to Ethernet MAC addresses (Layer 2); LE ARP maps ELAN MAC addresses (Layer 2) to ATM addresses (also Layer 2).

When a LEC first joins an ELAN, its LE ARP table has no dynamic entries, and the LEC has no information about destinations on or behind its ELAN. To learn about a destination when a packet is to be sent, the LEC follows this process to find the ATM address corresponding to the known MAC address:

1. The LEC sends an LE ARP request to the LES for its ELAN (point-to-point Control Direct VCC, link 1–7 in Figure 3-2).
2. If the MAC address is registered with the LES, the LES returns the corresponding ATM address. If not, the LES forwards the LE ARP request to all LECs on the ELAN (point-to-multipoint Control Distribute VCC, link 2–8 in Figure 3-2).
3. Any LEC that recognizes the MAC address responds with its ATM address (point-to-point Control Direct VCC, link 1–7 in Figure 3-2).
4. The LES forwards the response (point-to-multipoint Control Distribute VCC, link 2–8 in Figure 3-2).
5. The LEC adds the MAC address-ATM address pair to its LE ARP cache.
6. The LEC establishes a VCC to the desired destination and transmits packets to that ATM address (bidirectional, point-to-point Data Direct VCC, link 6–6 in Figure 3-2).

For unknown destinations, the LEC sends a packet to the BUS, which forwards the packet to all LECs. The BUS floods the packet because the destination might be behind a bridge that has not yet learned this particular address.

Sending Multicast Traffic

When a LEC sends broadcast, multicast, or unicast traffic with an unknown address, the following process occurs:

- The LEC sends the packet to the BUS (unidirectional, point-to-point Multicast Send VCC, link 4–9 in Figure 3-2).
- The BUS floods the packet to all LECs (unidirectional, point-to-multipoint Multicast Forward VCC, link 5–10 in Figure 3-2). This VCC branches at each switch. The switch forwards such packets to multiple outputs. (The switch does not examine the MAC addresses; it only forwards all packets it receives.)

LANE ATM Addressing Structure

On a LAN, packets are addressed using the MAC-layer addresses of the destination and source stations. To provide similar functionality for LANE, MAC-layer addressing must be supported. Every LEC must have a MAC address. In addition, every LANE component (LECS, LES, BUS, and LEC) must have a unique ATM address.

All LECs on the same interface have the same automatically assigned MAC address. That MAC address is also used as the end-system identifier (ESI) part of the ATM address. Although LEC MAC addresses are not unique, all ATM addresses are unique.

An ATM address has the same syntax as a network service access point (NSAP), but it is not a network-level address. The ATM address consists of the following:

- A 13-byte prefix that includes the following fields defined by the ATM Forum:
 - Authority and Format Identifier (AFI) field (1 byte)
 - Data Country Code (DCC) or International Code Designator (ICD) field (2 bytes)
 - Domain Specific Part Format Identifier (DFI) field (1 byte)
 - Administrative Authority field (3 bytes)
 - Reserved field (2 bytes)
 - Routing Domain field (2 bytes)
 - Area field (2 bytes)
- A 6-byte end-system
- A 1-byte selector field

Assigning ATM Addresses Automatically

Cisco provides the following method of constructing and assigning ATM and MAC addresses in an LECS database. A pool of 16 MAC addresses is assigned to each ATM module. For constructing ATM addresses, the following assignments are made to the LANE components:

- The prefix fields are the same for all LANE components in routers and in ATM modules for the Catalyst 5000 family and 6000 family switches; the prefix indicates the identity of the ATM switch. You might need to configure the prefix value on the ATM switch.
- The ESI field value assigned to every LEC on the interface is the first pool of MAC addresses assigned to the interface.
- The ESI field value assigned to every LES on the interface is the second pool of MAC addresses.
- The ESI field value assigned to the BUS on the interface is the third pool of MAC addresses.
- The ESI field value assigned to the LECS is the fourth pool of MAC addresses.
- The selector field value is set to the subinterface number (in hexadecimal notation) of the LANE component—except for the LECS, which has a selector field value of 00.

Because LANE components are defined on different subinterfaces of an ATM interface, the value of the selector field in an ATM address is different for each component. The result is a unique ATM address for each LANE component, even within the same Catalyst 5000 family switch. For more information about assigning components to subinterfaces, see the “ATM LANE Configuration Guidelines” section on page 3-9.

For example, if the MAC addresses assigned to an interface are 0800.200C.1000 through 0800.200C.100F, the ESI portion of the ATM addresses is assigned to LANE components as follows:

- Any LECS gets the ESI 0800.200c.1000.
- Any LEC gets the ESI 0800.200c.1001.
- The LES gets the ESI 0800.200c.1002.
- The BUS gets the ESI 0800.200c.1003.

Registering ILMI Addresses

Catalyst 5000 family and 6000 family switches build their ATM addresses by obtaining the ATM address prefix from the ATM switch. The switch combines the ATM address prefix with its own MAC address and the LEC subinterface number. After the ATM module determines its ATM address, it uses Interim Local Management Interface (ILMI) registration to register this address with the ATM switch. ILMI and signaling PVCs are set up by default.

Using the **atm vc-per-vp** command, you can configure the maximum number of virtual channel identifiers (VCIs) per virtual path identifier (VPI). If this value is configured when the ATM module registers with the ATM switch, the maximum number of VCIs per VPI is passed to the ATM switch. In this way, the ATM switch assigns to the Catalyst 5000 or 6000 family switch a VCI value for a switched virtual circuit (SVC) that is within the ATM switch range. The default is 10 VCI bits and 2 VPI bits on the ATM module. Any change from the default requires an ATM module reset.

Using VTP to Create LECs Automatically

You can configure Catalyst 5000 and 6000 family switches and the ATM modules to use VTP to create LECs automatically when VLANs are created on the Catalyst 5000 and 6000 family switches.

You must enable VTP on the ATM module and configure the LES/BUS and the LECS database for each VLAN/ELAN. LECs are created automatically based on the VTP mode of the switch in which the ATM module is installed:

- If the Catalyst switch is in VTP transparent mode, when you create a VLAN on the switch, a LEC is created automatically on all ATM modules installed in that switch.
- If the switch belongs to a VTP domain, when you create a VLAN on the switch, a LEC is created automatically on all ATM modules installed in all switches belonging to the same VTP domain.

For information about creating LECs automatically using VTP, see the “Creating LECs Automatically Using VTP” section on page 3-29.

Drafting an ATM LANE Implementation Plan

Before implementing LANE, create a LANE plan for your own LANE scenario. Determine the LANE components you want to use, their locations, their associated VLANs, and the necessary redundancy features. Note the ATM address of each LANE component on each subinterface of each participating device.

Your plan should include the following information:

- How many ELANs you will create, and whether they will be unrestricted or restricted membership ELANs
- The VLAN to which each ELAN maps
- The ELAN that will function as the default ELAN in the LECS database (optional)
- The device and interface where the LECS will be located
- The device, interface, and subinterface where the LES/BUS for each ELAN will be located
- The devices and subinterfaces where the LECs for each ELAN will be located

Default ATM LANE Configuration

Table 3-1 shows the ATM LANE default configuration.

Table 3-1 ATM LANE Default Configuration

Feature	Default Value
LANE components	No LECS database is configured No LES/BUS is configured No LECs are configured
PVCs	LMI and signaling PVCs are set up
Preferred PHY (dual PHY modules only)	PHY A
Output throttling	Disabled
ILMI keepalives	Disabled
UNI version	Autonegotiate (reverts to UNI 3.0 if autonegotiation fails)
VTP	Disabled

ATM LANE Configuration Guidelines

These guidelines apply when configuring LANE:

- The LECS is always assigned to the major interface. Assigning any other component to the major interface is identical to assigning that component to the 0 subinterface.
- The LES/BUS and the LEC of the *same* ELAN can be configured on the same subinterface.
- LECs of two *different* ELANs cannot be configured on the same subinterface.
- The LES/BUS for *different* ELANs cannot be configured on the same subinterface.
- All ATM switches have identical lists of the global LECS addresses with the identical priorities.
- The operating LECSs must use exactly the same configuration database. Create and maintain a configuration file containing the LECS database and load it onto devices using the **config net** command. This method minimizes errors and allows you to maintain the database centrally.
- The LANE subsystem supports up to 16 LECS addresses.

- The number of LES/BUSs that can be defined per ELAN is unlimited.
- When a LECS switchover occurs, no previously joined clients are affected.
- In a LES/BUS switchover, there is a momentary loss of clients until all clients are transferred to the new LES/BUS.
- LECSs come up as masters automatically until a higher level LECS takes priority.
- Using Fast Simple Server Redundancy Protocol (FSSRP), you can configure redundant LES/BUSs and LECSs to reduce the possibility of a server failure resulting in loss of communication on the LANE network. With redundant LES/BUSs and LECSs, LANE components can switch to the backup LES/BUS or LECS automatically if the primary server fails. For specific information on how to configure FSSRP, see the section “Configuring Fast SSRP for Redundant LANE Services” section on page 3-24.

**Note**

FSSRP works only with LECS and LES/BUS combinations on Cisco devices. Third-party LANE components interoperate with the LECS and LES/BUS functions of Cisco devices but cannot take advantage of the redundancy features. Additionally, FSSRP-unaware LECs on Cisco equipment will not be able to take advantage of FSSRP LES/BUS redundancy.

- With multiple LES/BUS pairs configured for a single ELAN, the priority of a given LES/BUS pair is established by the order in which it was entered in the LECS database. When a higher priority LES/BUS pair comes online, it takes over the functions of the current LES/BUS on the ELAN. For a short time after a power on, some LECs might change from one LES/BUS to another, depending upon the order in which the LES/BUSs come online.
- If no specified LES/BUS pair is up or connected to the master LECS, and more than one LES/BUS is defined for an ELAN, the LECS rejects any configuration request for that specific ELAN.
- Changes made to the list of LECS addresses on ATM switches can take up to one minute to propagate through the network. Changes made to the configuration database regarding LES/BUS addresses take effect almost immediately.
- If no designated LECS is operational or reachable, the ATM Forum-defined “well-known” LECS address is used.
- The LECS can be overridden on any subinterface by entering these commands:
 - **lane auto-config-atm-address**
 - **lane fixed-config-atm-address**
 - **lane config-atm-address** *atm-address-template*

**Note**

To avoid affecting LES/BUS/LEC redundancy, do not override any LECS, LES, or BUS addresses.

- In the event of an ATM network failure, there can be multiple master LECs and multiple active LES/BUSs for the same ELAN, resulting in a partitioned network. Clients continue to operate normally, but transmission between different partitions of the network is not possible. The system recovers when the network break is repaired.

Configuring ATM LANE

These sections describe how to configure ATM LANE on the ATM modules:

- Opening a Session from the Switch to the ATM Module, page 3-11
- Displaying Default ATM Addresses, page 3-11
- Configuring LECS ATM Addresses on a LightStream 1010 ATM Switch, page 3-13
- Setting Up the LES/BUS for an ELAN, page 3-14
- Setting Up a LEC for an ELAN, page 3-15
- Configuring the LECS Database, page 3-17
- Binding the LECS to the ATM Interface, page 3-23

Opening a Session from the Switch to the ATM Module

Enter the `session mod_num` command to open a session to the ATM module from the Catalyst 5000 or 6000 family switch in which the module is installed.

This example shows how to session to an ATM module installed in slot 5 of the Catalyst 5000 switch:

```
Console> (enable) session 5
Trying ATM-5...
Connected to ATM-5.
Escape character is '^]'.

ATM>
```

After opening the session, you see the ATM> prompt. You then have direct access only to the ATM module with which you have established a session.

The ATM module uses a subset of Cisco IOS software. Generally, Cisco IOS software works the same on the ATM module as it does on routers.

To configure the ATM module, you must use configuration mode. To enter configuration mode, enter the EXEC command **configure** at the privileged EXEC prompt (ATM#). You will see the following message, which asks you to specify the terminal, the nonvolatile RAM (NVRAM), or a file stored on a network server as the source of configuration commands:

```
Configuring from terminal, memory, or network [terminal]?
```

**Note**

You cannot configure from the network on the ATM modules.

Terminal configuration means changing the running configuration. You can save the running configuration into the NVRAM using the **copy running-config startup-config** command. When you configure from memory, the running configuration is updated from the NVRAM.

Displaying Default ATM Addresses

To help you configure the LECS database and the LECS addresses on the ATM switch, default ATM addresses for the LECS, LES, BUS, and LECs are automatically generated on the ATM module based on the ATM address prefix learned from the switch and the MAC address of the ATM module. (For more

information about the LANE default ATM addresses, see the “Assigning ATM Addresses Automatically” section on page 3-7.) Use one of these procedures to display the default ATM addresses on the ATM module.

If the ATM module (single PHY or dual PHY) is connected to a single ATM switch, you can display the default ATM addresses by performing this task:

Task	Command
Display default ATM addresses. (Record the addresses for later use.)	show lane default-atm-addresses

This example shows how to display the default ATM addresses on an ATM LANE module:

```
ATM#show lane default-atm-addresses
interface ATM0:
LANE Client:      47.00918100000000E04FACB401.00E04FACB070.**
LANE Server:      47.00918100000000E04FACB401.00E04FACB071.**
LANE Bus:         47.00918100000000E04FACB401.00E04FACB072.**
LANE Config Server: 47.00918100000000E04FACB401.00E04FACB073.00
note: ** is the subinterface number byte in hex

ATM#
```

If the ATM LANE module does not learn the ATM address prefix, ensure that the module is connected to the switch properly, that the interfaces on both the ATM module and the ATM switch are up, and that the ILMI PVC is established (enter the **show atm vc** command to see configured PVCs). If the interface is administratively down, you will need to issue a **no shutdown** command to bring the interface up.

This example shows that the ATM module could not learn the ATM address prefix from the ATM switch through ILMI:

```
ATM#show lane default-atm-addresses
interface ATM0:
LANE Client:      ...00E04FACB070.**
LANE Server:      ...00E04FACB071.**
LANE Bus:         ...00E04FACB072.**
LANE Config Server: ...00E04FACB073.00
note: ** is the subinterface number byte in hex

ATM#
```

If the ATM module (dual PHY) is connected to two different ATM switches, you must determine the default ATM addresses to use for both PHYs.

To display the default ATM addresses on a dual PHY module connected to two different ATM switches, perform this task:

	Task	Command
Step 1	Display the default ATM addresses for the first PHY.	show lane default-atm-addresses
Step 2	Enter configuration mode.	configure terminal
Step 3	Enter interface configuration mode.	interface atm0
Step 4	Change the preferred PHY to the one not currently in use.	atm preferred phy {A B}

	Task	Command
Step 5	Exit configuration mode.	Ctrl-Z
Step 6	Display the default ATM addresses for the second PHY.	show lane default-atm-addresses

This example shows how to display the default ATM address for both PHYs:

```
ATM#configure terminal
Enter configuration commands, one per line. End with Ctrl-Z.
ATM(config)#interface atm0
ATM(config-subif)#atm preferred phy A
ATM(config-subif)#end
ATM#show lane default-atm-addresses
interface ATM0:
LANE Client:      47.00918100000000E04FACB401.00E04FACB070.**
LANE Server:      47.00918100000000E04FACB401.00E04FACB071.**
LANE Bus:         47.00918100000000E04FACB401.00E04FACB072.**
LANE Config Server: 47.00918100000000E04FACB401.00E04FACB073.00
note: ** is the subinterface number byte in hex
ATM#configure terminal
Enter configuration commands, one per line. End with Ctrl-Z.
ATM(config)#interface atm0
ATM(config-subif)#atm preferred phy B
ATM(config-subif)#end
ATM#show lane default-atm-addresses
interface ATM0:
LANE Client:      47.00918100000000603E7B2001.00000C407575.**
LANE Server:      47.00918100000000603E7B2001.00000C407576.**
LANE Bus:         47.00918100000000603E7B2001.00000C407577.**
LANE Config Server: 47.00918100000000603E7B2001.00000C407578.00
note: ** is the subinterface number byte in hex
ATM#
```

Configuring LECS ATM Addresses on a LightStream 1010 ATM Switch

You must program all LECS addresses into each ATM switch (such as a LightStream 1010 switch) connected to an ATM module in your LANE network. Programming the LECS addresses allows the LECs and LECs to determine the LECs addresses dynamically through ILMI.

To configure a LECS ATM address on a LightStream 1010 ATM switch, perform this task in privileged mode for each connected LightStream 1010 ATM switch:

	Task	Command
Step 1	Enter configuration mode.	configure terminal
Step 2	Enter the address of the LECS.	atm lecs-address-default <i>lecs_atm_address</i>
Step 3	Exit configuration mode.	Ctrl-Z
Step 4	Verify the configured LECS addresses.	show atm ilmi-configuration

This example shows how to configure a LECS address on the LightStream 1010 ATM switch and verify the configuration:

```
Switch#configure terminal
Enter configuration commands, one per line. End with CNTL/Z.
Switch(config)#atm lecs-address-default 47.0091.8100.0000.00e0.4fac.b401.0010.0daa.cc43.00
Switch(config)#^Z
Switch#show atm ilmi-configuration

LECS Address(es):
 47.0091.8100.0000.00e0.4fac.b401.0010.0daa.cc43.00
Switch#
```

Setting Up the LES/BUS for an ELAN

You must configure at least one LES/BUS for each ELAN in the ATM LANE network. The LES/BUS for each ELAN should be configured on a separate subinterface of the major ATM interface on the ATM module. The LES/BUS and the LEC of the same ELAN can be configured on the same subinterface. The LES/BUSs for different ELANs cannot be configured on the same subinterface.



Caution

If you plan to configure the ELAN in Step 3 for restricted membership, make sure the ELAN name you specify is exactly the same as the ELAN name specified in the LECS database. If the ELAN name specified in the **lane server-bus** command does not match the LECS database entry linking the LEC to an ELAN, the LEC is not allowed to join the ELAN.

To specify the LES/BUS for an ELAN, perform this task:

Task	Command
Step 1 Enter configuration mode.	configure terminal
Step 2 Specify the subinterface for the first ELAN and the link type.	interface atm 0. subinterface-number <i>point-to-point multipoint</i>
Step 3 Enable the LES/BUS for an ELAN on the subinterface (you cannot configure more than one LES/BUS per subinterface).	lane server-bus ethernet elan-name
Step 4 Repeat Steps 2 and 3 for all LES/BUSs you want to configure on this ATM module.	
Step 5 Exit configuration mode.	Ctrl-Z
Step 6 Verify the LES/BUS configuration.	show lane server



Note

The LES/BUSs are not fully operational until one or more LECs are configured and the LECS database is configured and bound to the ATM module interface.

This example shows how to specify the LES/BUS for an ELAN and verify the configuration:

```
ATM#configure terminal
Enter configuration commands, one per line. End with CNTL/Z.
ATM(config)#interface atm0.1
ATM(config-subif)#lane server-bus ethernet default
ATM(config-subif)#interface atm0.2
ATM(config-subif)#lane server-bus ethernet Eng_ELAN
ATM(config-subif)#^Z
ATM#show lane server
LE Server ATM0.1 ELAN name: default Admin: up State: operational
type: ethernet Max Frame Size: 1516
ATM address: 47.00918100000000E04FACB401.00100DAACC41.01
LECS used: 47.007900000000000000000000.00A03E000001.00 NOT yet connected

LE Server ATM0.2 ELAN name: Eng_ELAN Admin: up State: operational
type: ethernet Max Frame Size: 1516
ATM address: 47.00918100000000E04FACB401.00100DAACC41.02
LECS used: 47.007900000000000000000000.00A03E000001.00 NOT yet connected

ATM#
```

Setting Up a LEC for an ELAN

LECs serve to pass traffic between VLANs on the Catalyst switches and ELANs in the ATM network. You can configure one or more LECs for one or more ELANs on the ATM modules.

Before you set up a LEC on the ATM module, you must configure a VLAN on the switch and the LES/BUS for an ELAN on an ATM module subinterface. When you configure a LEC on the ATM module, you map a VLAN on the Catalyst 5000 or 6000 family switch to an ATM ELAN. For information on configuring VLANs on the Catalyst 5000 or 6000 family supervisor engine, refer to the *Software Configuration Guide* for your switch. For information on configuring the LES/BUS for an ELAN, refer to the “Setting Up the LES/BUS for an ELAN” section on page 3-14.



Note

Using the VLAN Trunk Protocol (VTP), you can cause LECs to be created automatically when you configure VLANs on the Catalyst 5000 family supervisor engine. For more information on using VTP to create LECs automatically, see the “Creating LECs Automatically Using VTP” section on page 3-29.



Note

If you later want to associate a LEC with a different ELAN, change the LECS database configuration before you change the LEC configuration on the subinterface. For information on configuring the LECS database, see the “Configuring the LECS Database” section on page 3-17.

To set up a LEC for an ELAN, perform this task:

	Task	Command
Step 1	Enter configuration mode.	configure terminal
Step 2	Specify a subinterface for the LEC.	interface atm 0.subinterface

Task	Command
Step 3 Create the LEC, specifying the VLAN number and the ELAN name to which to bind the LEC.	lane client ethernet <i>vlan_id elan-name</i>
Step 4 Repeat Steps 2 and 3 for each LEC you want to configure.	
Step 5 Exit configuration mode.	Ctrl-Z
Step 6 Verify the LEC configuration.	show lane client

**Note**

The LECs do not come up until the LES/BUSs are configured and the LECS database is configured and bound to the ATM module interface.

This example shows how to configure LECs and verify the configuration:

```

ATM#configure terminal
Enter configuration commands, one per line. End with CNTL/Z.
ATM(config)#interface atm0.1
ATM(config-subif)#lane client ethernet 1 default
ATM(config-subif)#interface atm0.2
ATM(config-subif)#lane client ethernet 2 Eng_ELAN
ATM(config-subif)#^Z
ATM#show lane client
LE Client ATM0.1 ELAN name: default Admin: up State: initialState
Client ID: unassigned Next join attempt in 0 seconds
Join Attempt: 4
Last Fail Reason: Config VC being released
HW Address: 0010.0daa.cc40 Type: ethernet Max Frame Size: 1516
VLANID: 1
ATM Address: 47.00918100000000E04FACB401.00100DAACC40.01

VCD rxFrames txFrames Type ATM Address
0 0 0 configure 47.0079000000000000000000000000.00A03E000001.00
0 0 0 direct 00.0000000000000000000000000000.000000000000.00
0 0 0 distribute 00.0000000000000000000000000000.000000000000.00
0 0 0 send 00.0000000000000000000000000000.000000000000.00
0 0 0 forward 00.0000000000000000000000000000.000000000000.00

LE Client ATM0.2 ELAN name: Eng_ELAN Admin: up State: initialState
Client ID: unassigned Next join attempt in 1 seconds
Join Attempt: 2
Last Fail Reason: Config VC being released
HW Address: 0010.0daa.cc40 Type: ethernet Max Frame Size: 1516
VLANID: 2
ATM Address: 47.00918100000000E04FACB401.00100DAACC40.02

VCD rxFrames txFrames Type ATM Address
0 0 0 configure 47.0079000000000000000000000000.00A03E000001.00
VCD rxFrames txFrames Type ATM Address
0 0 0 direct 00.0000000000000000000000000000.000000000000.00
0 0 0 distribute 00.0000000000000000000000000000.000000000000.00
0 0 0 send 00.0000000000000000000000000000.000000000000.00
0 0 0 forward 00.0000000000000000000000000000.000000000000.00

ATM#

```

Configuring the LECS Database

The LECS database contains LANE configuration information, including ELAN name-to-LES/BUS ATM address mappings, LEC address-to-ELAN name mappings, and the name of the default ELAN, if specified. You must configure at least one LECS database in the ATM LANE network.

You can configure redundant LECSs. Redundant LECSs should be configured on different devices in the LANE network. If you configure more than one LECS, make sure that all databases with the same name are identical.

These sections describe how to set up the LECS database on the ATM module:

- Setting Up One (Default) ELAN in the LECS Database, page 3-17
- Setting Up Unrestricted-Membership ELANs in the LECS Database, page 3-18
- Setting Up Restricted-Membership ELANs in the LECS Database, page 3-20

Setting Up One (Default) ELAN in the LECS Database

When you configure a Catalyst 5000 family ATM module as the LECS for one default ELAN, you provide a name for the database, the ATM address of the LES/BUS for the ELAN, and the name of the default ELAN.

The default ELAN cannot be a restricted-membership ELAN. You do not need to specify the ATM or MAC addresses of the LECs for the default ELAN.

On the dual PHY ATM modules, you must configure redundant LES/BUS/LECS, one for each PHY.



Note

Before beginning the LECS database configuration, make sure you have configured the LES/BUS and LEC for the default ELAN (see the “Setting Up the LES/BUS for an ELAN” section on page 3-14 and the “Setting Up a LEC for an ELAN” section on page 3-15).

To set up the LECS for one default ELAN, perform this task:

	Task	Command
Step 1	Display the ATM address of the LES/BUS for the default ELAN.	show lane server
Step 2	Enter configuration mode.	configure terminal
Step 3	Enter database configuration mode, specifying a LANE database name.	lane database <i>database-name</i>
Step 4	Bind the name of the ELAN to the ATM address of the LES/BUS.	name <i>elan-name</i> server-atm-address <i>atm-address</i>
Step 5	In the configuration database, provide a default name of the ELAN.	default-name <i>elan-name</i>
Step 6	Exit from configuration mode.	Ctrl-Z
Step 7	Verify the LECS database configuration.	show lane database

**Note**

After you configure the LECS database, you must bind the LECS database to the major ATM interface (ATM0) on the ATM module. For information on how to bind the database to the interface, see the “Binding the LECS to the ATM Interface” section on page 3-23.

This example shows how to display the ATM address of the LES/BUS of the default ELAN, how to configure the LECS database for the default ELAN, and how to verify the configuration:

```
ATM#show lane server
LE Server ATM0.1 ELAN name: default Admin: up State: operational
type: ethernet Max Frame Size: 1516
ATM address: 47.00918100000000E04FACB401.00100DAACC41.01
LECS used: 47.00790000000000000000000000.00A03E000001.00 NOT yet connected

ATM#configure terminal
Enter configuration commands, one per line. End with CNTL/Z.
ATM(config)#lane database LANE_Backbone
ATM(lane-config-database)#name default server-atm-address 47.00918100000000E04FACB401.00100DAACC41.01
ATM(lane-config-database)#default-name default
ATM(lane-config-database)#^Z
ATM#show lane database

LANE Config Server database table 'LANE_Backbone'
default elan: default
elan 'default': un-restricted
server 47.00918100000000E04FACB401.00100DAACC41.01 (prio 0)

ATM#
```

Setting Up Unrestricted-Membership ELANs in the LECS Database

When you configure unrestricted-membership ELANs in the LECS database, you create database entries that link the name of each ELAN to the ATM address of its LES/BUS. With unrestricted-membership ELANs, you do not need to specify the ATM or MAC addresses of the LECs for each ELAN. If desired, you can specify a default ELAN for LECs not bound to an ELAN explicitly.

**Note**

Before beginning the LECS database configuration, make sure you have configured a LES/BUS and LEC for each ELAN (see the “Setting Up the LES/BUS for an ELAN” section on page 3-14 and the “Setting Up a LEC for an ELAN” section on page 3-15).

To configure unrestricted-membership ELANs in the LECS database, perform this task:

	Task	Command
Step 1	Display the ATM addresses of the configured LES/BUSs.	show lane server [interface atm0]. <i>subinterface</i>] name elan-name] [brief]
Step 2	Enter configuration mode.	configure terminal
Step 3	Enter database configuration mode, specifying a LANE database name.	lane database <i>database-name</i>

	Task	Command
Step 4	Bind the ELAN name to the ATM address of the LES/BUS for that ELAN (use the ATM address displayed in the show lane server command output). Repeat this step for each ELAN in the LANE network.	name <i>elan-name</i> server-atm-address <i>atm-address</i>
Step 5	(Optional) Specify an ELAN as the default ELAN for LECs not bound to an ELAN explicitly.	default-name <i>elan-name</i>
Step 6	Exit from configuration mode.	Ctrl-Z
Step 7	Verify the LECS database configuration.	show lane database

**Note**

After you configure the LECS database, you must bind the LECS database to the major ATM interface (ATM0) on the ATM module. For information on how to bind the database to the interface, see the “Binding the LECS to the ATM Interface” section on page 3-23.

This example shows how to display the ATM address of the LES/BUSs for all ELANs, how to configure the LECS database for each ELAN, how to specify a default ELAN, and how to verify the configuration:

ATM#show lane server

```
LE Server ATM0.1  ELAN name: default  Admin: up  State: operational
type: ethernet      Max Frame Size: 1516
ATM address: 47.00918100000000E04FACB401.00100DAACC41.01
LECS used: 47.007900000000000000000000.00A03E000001.00 NOT yet connected

LE Server ATM0.2  ELAN name: Eng_ELAN  Admin: up  State: operational
type: ethernet      Max Frame Size: 1516
ATM address: 47.00918100000000E04FACB401.00100DAACC41.02
LECS used: 47.007900000000000000000000.00A03E000001.00 NOT yet connected

LE Server ATM0.3  ELAN name: Mktg_ELAN  Admin: up  State: operational
type: ethernet      Max Frame Size: 1516
ATM address: 47.00918100000000E04FACB401.00100DAACC41.03
LECS used: 47.007900000000000000000000.00A03E000001.00 NOT yet connected
```

ATM#configure terminal

```
Enter configuration commands, one per line.  End with CNTL/Z.
ATM(config)#lane database LANE_Backbone
ATM(lane-config-database)#name default server-atm-address 47.00918100000000E04FACB401.00100DAACC41.01
ATM(lane-config-database)#name Eng_ELAN server-atm-address 47.00918100000000E04FACB401.00100DAACC41.02
ATM(lane-config-database)#name Mktg_ELAN server-atm-address 47.00918100000000E04FACB401.00100DAACC41.03
ATM(lane-config-database)#default-name default
ATM(lane-config-database)#^Z
```

The **show lane database** command displays the database configuration:

```
ATM#show lane database

LANE Config Server database table 'LANE_Backbone'
default elan: default
elan 'default': un-restricted
  server 47.00918100000000E04FACB401.00100DAACC41.01 (prio 0)
elan 'Eng_ELAN': un-restricted
  server 47.00918100000000E04FACB401.00100DAACC41.02 (prio 0)
elan 'Mktg_ELAN': un-restricted
  server 47.00918100000000E04FACB401.00100DAACC41.03 (prio 0)

ATM#
```

Setting Up Restricted-Membership ELANs in the LECS Database

When you configure restricted-membership ELANs in the LECS database, you create database entries that link the name of each ELAN to the ATM address of its LES/BUS. In addition, you must specify the ATM or MAC addresses of the LECs belonging to each ELAN. If desired, you can specify a default ELAN for LECs not bound to an ELAN explicitly. The default ELAN must be an unrestricted-membership ELAN.

If there are LECs for a given restricted-membership ELAN configured on multiple Catalyst 5000 family ATM modules, you must bind the ATM or MAC address of each LEC explicitly with the name of that ELAN using the **client-atm-address** database configuration command. For example, if you configure three LECs for a particular restricted-membership ELAN on three different ATM modules, you must configure three LECS database entries, one entry for each LEC. Each entry binds the ATM or MAC address of each LEC to the restricted-membership ELAN.



Note

Before beginning the LECS database configuration, make sure you have configured a LES/BUS and LEC for each ELAN (see the “Setting Up the LES/BUS for an ELAN” section on page 3-14 and the “Setting Up a LEC for an ELAN” section on page 3-15).

To configure restricted-membership ELANs in the LECS database, perform this task:

	Task	Command
Step 1	Display the ATM addresses of the configured LES/BUSs.	show lane server [interface atm0 [.subinterface] name elan-name] [brief]
Step 2	Display the ATM addresses of the configured LECs.	show lane client [interface atm0 [.subinterface] name elan-name] [brief]
Step 3	Enter configuration mode.	configure terminal
Step 4	Enter database configuration mode, specifying a LANE database name.	lane database <i>database-name</i>
Step 5	Bind the restricted-membership ELAN name to the ATM address of the LES/BUS for that ELAN. Repeat this step for every restricted-membership ELAN in the LANE network.	name elan-name server-atm-address atm-address restricted

Task	Command
Step 6 Bind a specific LEC ATM address with a specific restricted-membership ELAN. Repeat this step for every LEC belonging to the restricted-membership ELAN in the LANE network (including LECs configured on other ATM modules).	client-atm-address <i>atm-address</i> name <i>elan-name</i>
Step 7 (Optional) Configure a default ELAN for LECs not bound to an ELAN explicitly by binding the default ELAN name to the ATM address of the LES/BUS for the default ELAN. The default ELAN must be an unrestricted-membership ELAN.	name <i>default-elan-name</i> server-atm-address <i>atm-address</i>
Step 8 (Optional) Specify the default ELAN.	default-name <i>default-elan-name</i>
Step 9 Exit from configuration mode.	Ctrl-Z
Step 10 Verify the LECS database configuration.	show lane database



Note After you configure the LECS database, you must bind the LECS database to the major ATM interface (ATM0) on the ATM module. For information on how to bind the database to the interface, see the “Binding the LECS to the ATM Interface” section on page 3-23.

This example shows how to display the ATM address of the LES/BUSs and LECs, how to configure the LECS database for restricted-membership ELANs, how to specify a default ELAN, and how to verify the configuration:

ATM#show lane server

```
LE Server ATM0.1 ELAN name: default Admin: up State: operational
type: ethernet Max Frame Size: 1516
ATM address: 47.00918100000000E04FACB401.00100DAACC41.01
LECS used: 47.007900000000000000000000.00A03E000001.00 NOT yet connected
```

```
LE Server ATM0.2 ELAN name: Eng_ELAN Admin: up State: operational
type: ethernet Max Frame Size: 1516
ATM address: 47.00918100000000E04FACB401.00100DAACC41.02
LECS used: 47.007900000000000000000000.00A03E000001.00 NOT yet connected
```

```
LE Server ATM0.3 ELAN name: Mktg_ELAN Admin: up State: operational
type: ethernet Max Frame Size: 1516
ATM address: 47.00918100000000E04FACB401.00100DAACC41.03
LECS used: 47.007900000000000000000000.00A03E000001.00 NOT yet connected
```

ATM#show lane client brief

```
LE Client ATM0.1 ELAN name: default Admin: up State: initialState
Client ID: unassigned Next join attempt in 38 seconds
Join Attempt: 121
Last Fail Reason: Config VC being released
HW Address: 0010.0daa.cc40 Type: ethernet Max Frame Size: 1516
VLANID: 1
ATM Address: 47.00918100000000E04FACB401.00100DAACC40.01
```

```
LE Client ATM0.2 ELAN name: Eng_ELAN Admin: up State: initialState
Client ID: unassigned Next join attempt in 60 seconds
Join Attempt: 90
Last Fail Reason: Config VC being released
HW Address: 0010.0daa.cc40 Type: ethernet Max Frame Size: 1516
VLANID: 2
ATM Address: 47.00918100000000E04FACB401.00100DAACC40.02
```

```
LE Client ATM0.3 ELAN name: Mktg_ELAN Admin: up State: initialState
Client ID: unassigned Next join attempt in 39 seconds
Join Attempt: 89
Last Fail Reason: Config VC being released
HW Address: 0010.0daa.cc40 Type: ethernet Max Frame Size: 1516
VLANID: 3
ATM Address: 47.00918100000000E04FACB401.00100DAACC40.03
```

ATM#configure terminal

Enter configuration commands, one per line. End with CNTL/Z.

ATM(config)#**lane database LANE_Backbone**

ATM(lane-config-database)#**name Eng_ELAN server-atm-address 47.00918100000000E04FACB401.00100DAACC41.02 restricted**

ATM(lane-config-database)#**name Mktg_ELAN server-atm-address 47.00918100000000E04FACB401.00100DAACC41.03 restricted**

ATM(lane-config-database)#**client-atm-address 47.00918100000000E04FACB401.00100DAACC40.02 name Eng_ELAN**

ATM(lane-config-database)#**client-atm-address 47.00918100000000E04FACB401.00100DAACC40.03 name Mktg_ELAN**

ATM(lane-config-database)#**name default server-atm-address 47.00918100000000E04FACB401.00100DAACC41.01**

ATM(lane-config-database)#**default-name default**

ATM(lane-config-database)#**^Z**

The **show lane database** command displays the database configuration:

```
ATM#show lane database

LANE Config Server database table 'LANE_Backbone'
default elan: default
elan 'Eng_ELAN': restricted
  server 47.00918100000000E04FACB401.00100DAACC41.02 (prio 0)
  atm client 47.00918100000000E04FACB401.00100DAACC40.02
elan 'Mktg_ELAN': restricted
  server 47.00918100000000E04FACB401.00100DAACC41.03 (prio 0)
  atm client 47.00918100000000E04FACB401.00100DAACC40.03
elan 'default': un-restricted
  server 47.00918100000000E04FACB401.00100DAACC41.01 (prio 0)

ATM#
```

Binding the LECS to the ATM Interface

Before LANE communication can occur, you must bind the LECS database to the major interface on the ATM module.

To bind the LECS database to the ATM module interface, perform this task:

	Task	Command
Step 1	Enter configuration mode.	configure terminal
Step 2	Select the ATM interface.	interface atm0
Step 3	Specify the address of the LECS (enter the auto-config-atm-address keyword to use the autogenerated LECS ATM address).	lane config { auto-config-atm-address config-atm-address lecs_atm_address }
Step 4	Bind the LECS database to the interface.	lane config database <i>database-name</i>
Step 5	Exit configuration mode.	Ctrl-Z
Step 6	Verify that the LECS is up and running.	show lane configuration

This example shows how to bind the autogenerated LECS ATM address and the LECS database to the major ATM interface and how to verify the configuration:

```

ATM#configure terminal
Enter configuration commands, one per line. End with CNTL/Z.
ATM(config)#interface atm0
ATM(config-if)#lane config auto-config-atm-address
ATM(config-if)#lane config database LANE_Backbone
ATM(config-if)#^Z
ATM#show lane configuration
LE Config Server ATM0 config table: LANE_Backbone
Admin: up State: operational
LECS Mastership State: active master
list of global LECS addresses (58 seconds to update):
47.00918100000000E04FACB401.00100DAACC43.00 <----- me
ATM Address of this LECS: 47.00918100000000E04FACB401.00100DAACC43.00 (auto)
 vcd rxCnt txCnt callingParty
     5     0     0 47.00918100000000E04FACB401.00100DAACC41.03 LES Mktg_ELAN 0
active
     6     0     0 47.00918100000000E04FACB401.00100DAACC41.02 LES Eng_ELAN 0
active
    11     1     1 47.00918100000000E04FACB401.00100DAACC41.01 LES default 0
active
cumulative total number of unrecognized packets received so far: 0
cumulative total number of config requests received so far: 3
cumulative total number of config failures so far: 1
    cause of last failure: no configuration
    culprit for the last failure: 47.00918100000000E04FACB401.00E04FACB070.04

ATM#

```

Configuring Fast SSRP for Redundant LANE Services

With Fast Simple Server Redundancy Protocol (FSSRP), you can configure redundant LES/BUS pairs for each ELAN. FSSRP differs from the previously implemented Simple Server Redundancy Protocol (SSRP) in that all configured LESs of an ELAN are active. This means FSSRP-aware redundant LES/BUS pairs can accept join requests from any FSSRP-aware client.

LECs that are FSSRP aware have virtual circuits established to every single LES/BUS in the ELAN. Because virtual circuit connections already exist between all LECs and LES/BUS pairs in the ELAN, the LECs can switch over to another LES/BUS pair without any noticeable delay should a failure occur.

When you configure more than one LES/BUS pair for an ELAN, one LES/BUS takes precedence over others based on the order in which they are entered into the LECS database.



Note

Redundant LES/BUS pairs for a single ELAN should be configured on different ATM LANE modules in the LANE network for maximum fault tolerance.

Configuring redundant LES/BUS pairs for an ELAN is a two-part process:

- You must first configure the redundant LES/BUS pairs on subinterfaces for that ELAN.
- You must then enter the ATM addresses of the redundant LES/BUS pairs into the LECS database for the ELAN.

To configure the LES/BUS pairs, perform the following task:

	Task	Command
Step 1	Enter configuration mode.	configure terminal
Step 2	Specify the major interface.	interface atm0
Step 3	Enable FSSRP on the major interface.	lane fssrp
Step 4	Specify the subinterface for the first ELAN.	interface atm 0. subinterface-number
Step 5	Enable the LES/BUS for an ELAN on the subinterface (you cannot configure more than one LES/BUS per subinterface).	lane server-bus ethernet elan-name
Step 6	Repeat Steps 2 and 3 for all LES/BUSs you want to configure on this ATM module.	
Step 7	Exit configuration mode.	Ctrl-Z
Step 8	Verify the LES/BUS configuration.	show lane server



Note

The LES/BUSs are not fully operational until one or more LECs are configured and the LECS database is configured and bound to the ATM module interface.

This example shows how to specify the LES/BUS for an ELAN and verify the configuration:

```
ATM#configure terminal
Enter configuration commands, one per line. End with CNTL/Z.
ATM(config)#interface atm0.1
ATM(config-subif)#lane server-bus ethernet default
ATM(config-subif)#interface atm0.2
ATM(config-subif)#lane server-bus ethernet Eng_ELAN
ATM(config-subif)#^Z
ATM#show lane server
LE Server ATM0.1 ELAN name: default Admin: up State: operational
type: ethernet Max Frame Size: 1516
ATM address: 47.00918100000000E04FACB401.00100DAACC41.01
LECS used: 47.00790000000000000000000000.00A03E000001.00 NOT yet connected

LE Server ATM0.2 ELAN name: Eng_ELAN Admin: up State: operational
type: ethernet Max Frame Size: 1516
ATM address: 47.00918100000000E04FACB401.00100DAACC41.02
LECS used: 47.00790000000000000000000000.00A03E000001.00 NOT yet connected

ATM#
```

To add the redundant LES/BUS pairs to the LECS, perform this task:

	Task	Command
Step 1	Display the ATM address of the LES/BUS for the ELAN.	show lane server
Step 2	Enter configuration mode	configure terminal
Step 3	Enter database configuration mode, specifying a LANE database name.	lane database <i>database-name</i>
Step 4	Bind the name of the ELAN to the ATM addresses of the LES/BUS pairs in the order you want the services to fail over.	name <i>elan-name</i> server-atm-address <i>atm-address</i>
Step 5	In the configuration database, provide a default name of the ELAN.	default-name <i>elan-name</i>
Step 6	Exit from configuration mode.	Ctrl-Z
Step 7	Verify the LECS database configuration.	show lane database

This example shows how to display the ATM address of the LES/BUS of the default ELAN, how to configure the LECS database for the default ELAN, and how to verify the configuration:

```
ATM#show lane server
LE Server ATM0.1 ELAN name: default Admin: up State: operational
type: ethernet Max Frame Size: 1516
ATM address: 47.00918100000000E04FACB401.00100DAACC41.01
LECS used: 47.007900000000000000000000.00A03E000001.00 NOT yet connected
```

```
ATM#configure terminal
Enter configuration commands, one per line. End with CNTL/Z.
ATM(config)#lane database LANE_Backbone
ATM(lane-config-database)#name default server-atm-address 47.00918100000000E04FACB401.00100DAACC41.01
ATM(lane-config-database)#default-name default
ATM(lane-config-database)#^Z
ATM#show lane database
```

```
LANE Config Server database table 'LANE_Backbone'
default elan: default
elan 'default': un-restricted
server 47.00918100000000E04FACB401.00100DAACC41.01 (prio 0)
```

Monitoring and Maintaining LANE

After configuring LANE components on the LANE module, you can display a variety of information on their status. To show LANE information, perform any of these tasks in user EXEC or privileged EXEC mode:

Task	Command
<ul style="list-style-type: none"> Display complete LANE configuration and status information for LES/BUSs, LECs, and LECSs. 	show lane
<ul style="list-style-type: none"> Display the global and per-VCC LANE information for all the LANE components and ELANs configured on an interface or any of its subinterfaces. 	show lane [interface atm0 [.subinterface-number] name elan-name] [brief]
<ul style="list-style-type: none"> Display the global and per-VC LANE information for the LES configured on a specified subinterface or ELAN. 	show lane server [interface atm0 [.subinterface-number] name elan-name] [brief]
<ul style="list-style-type: none"> Display the global and per-VC LANE information for the BUS configured on any subinterface or ELAN. 	show lane bus [interface atm0 [.subinterface-number] name elan-name] [brief]
<ul style="list-style-type: none"> Display the global and per-VC LANE information for all LECs configured on any subinterface or ELAN. 	show lane client [interface atm0 [.subinterface-number] name elan-name] [brief]
<ul style="list-style-type: none"> Display the global and per-VC LANE information for the LECS configured on any interface. 	show lane config
<ul style="list-style-type: none"> Display the LECS database. 	show lane database [database-name]
<ul style="list-style-type: none"> Display the LE ARP table of the LECs configured on the specified subinterface or ELAN. 	show lane le-arp [interface atm0 [.subinterface-number] name elan-name]
<ul style="list-style-type: none"> Display ATM VC information. 	show atm vc [vcd_number]

This example shows how to display brief information on all configured LANE components:

```

ATM#show lane brief
LE Server ATM0.1 ELAN name: default Admin: up State: operational
type: ethernet Max Frame Size: 1516
ATM address: 47.00918100000000E04FACB401.00100DAACC41.01
LECS used: 47.00918100000000E04FACB401.00100DAACC43.00 connected, vcd 12
control distribute: vcd 19, 3 members, 27723 packets

LE BUS ATM0.1 ELAN name: default Admin: up State: operational
type: ethernet Max Frame Size: 1516
ATM address: 47.00918100000000E04FACB401.00100DAACC42.01
data forward: vcd 23, 3 members, 174529 packets, 0 unicasts

LE Client ATM0.1 ELAN name: default Admin: up State: operational
Client ID: 1 LEC up for 15 hours 9 minutes 47 seconds
Join Attempt: 140
HW Address: 0010.0daa.cc40 Type: ethernet Max Frame Size: 1516
VLANID: 1
ATM Address: 47.00918100000000E04FACB401.00100DAACC40.01

LE Config Server ATM0 config table: LANE_Backbone
Admin: up State: operational
LECS Mastership State: active master
list of global LECS addresses:
47.00918100000000E04FACB401.00100DAACC43.00
ATM Address of this LECS: 47.00918100000000E04FACB401.00100DAACC43.00 (auto)

LE Server ATM0.2 ELAN name: Eng_ELAN Admin: up State: operational
type: ethernet Max Frame Size: 1516
ATM address: 47.00918100000000E04FACB401.00100DAACC41.02
LECS used: 47.00918100000000E04FACB401.00100DAACC43.00 connected, vcd 8
control distribute: vcd 31, 1 members, 27287 packets

LE BUS ATM0.2 ELAN name: Eng_ELAN Admin: up State: operational
type: ethernet Max Frame Size: 1516
ATM address: 47.00918100000000E04FACB401.00100DAACC42.02
data forward: vcd 35, 1 members, 28190 packets, 0 unicasts

```

```

LE Client ATM0.2 ELAN name: Eng_ELAN Admin: up State: operational
Client ID: 1 LEC up for 15 hours 9 minutes 34 seconds
Join Attempt: 109
HW Address: 0010.0daa.cc40 Type: ethernet Max Frame Size: 1516
VLANID: 2
ATM Address: 47.00918100000000E04FACB401.00100DAACC40.02

LE Server ATM0.3 ELAN name: Mktg_ELAN Admin: up State: operational
type: ethernet Max Frame Size: 1516
ATM address: 47.00918100000000E04FACB401.00100DAACC41.03
LECS used: 47.00918100000000E04FACB401.00100DAACC43.00 connected, vcd 7
control distribute: vcd 54, 1 members, 27250 packets

LE BUS ATM0.3 ELAN name: Mktg_ELAN Admin: up State: operational
type: ethernet Max Frame Size: 1516
ATM address: 47.00918100000000E04FACB401.00100DAACC42.03
data forward: vcd 58, 1 members, 28152 packets, 0 unicasts

LE Client ATM0.3 ELAN name: Mktg_ELAN Admin: up State: operational
Client ID: 1 LEC up for 15 hours 8 minutes 20 seconds
Join Attempt: 109
HW Address: 0010.0daa.cc40 Type: ethernet Max Frame Size: 1516
VLANID: 3
ATM Address: 47.00918100000000E04FACB401.00100DAACC40.03

```

Creating LECs Automatically Using VTP

When you create and modify VLANs on a Catalyst 5000 or 6000 family switch that belongs to a VTP domain, VTP automatically distributes VLAN configuration information over trunk links to all devices in the VTP domain. VTP is transmitted on all trunk connections, including ATM LANE.

By default, VTP is disabled on the ATM modules. When you enable VTP on an ATM module, you can have ATM modules automatically create LECs for VLANs created on the Catalyst 5000 or 6000 family switch.

You can use VTP to set up LECs in both VTP transparent and nontransparent (server or client) mode. If the Catalyst 5000 or 6000 family switch is in VTP transparent mode, configuring a VLAN creates LECs on ATM modules installed only in the switch on which you configured the VLAN.

If the Catalyst 5000 or 6000 family switch is in VTP server mode, configuring a VLAN creates LECs on all ATM modules on all Catalyst 5000 or 6000 family switches in the same VTP domain (both clients and servers).



Note

You might need to reload the ATM module after you configure VTP for the VTP creation of LECs to take effect.

Automatic creation of LECs using VTP is supported in Catalyst 5000 family software release 2.1 or later with ATM module software release 3.1 or later.

This procedure describes how to configure the Catalyst 5000 family and 6000 family switches and the ATM module so that when you create a VLAN on the switch, LECs are created on all ATM modules in all switches in the VTP domain (in VTP transparent mode, only ATM modules on the local switch are affected):

-
- Step 1** Configure a VTP domain on the Catalyst 5000 or 6000 family switches.
- Every switch with an ATM module on which you want LECs created automatically must belong to the same VTP domain. For information on configuring VTP, refer to the *Software Configuration Guide* for your switch.
- Step 2** Enable VTP on the ATM module.
- You must enable VTP on every ATM module on which you want LECs created automatically. For information on enabling VTP on the ATM module, see the “Using VTP to Create LECs Automatically” section on page 3-8.
- Step 3** Configure at least one LES/BUS for each VLAN/ELAN you will configure.
- VTP cannot create the LECs automatically unless one or more LES/BUSs are configured for each VLAN/ELAN. The ELAN name for VLAN 1 *must* be “default.” For information on configuring the LES/BUS, see the “Setting Up the LES/BUS for an ELAN” section on page 3-14.
-
-  **Note** VTP does *not* create or configure the LES/BUS for VLANs/ELANs.
-
- Step 4** Configure the LECS database with ELAN name-to-LES/BUS mappings for all VLANs/ELANs you will configure.
- VTP does *not* create or configure the LECS database. Use the name of the VTP domain configured on the Catalyst 5000 or 6000 family switch as the LECS database name. VTP cannot create the LECs automatically unless the LECS database is configured properly. LECs can be created automatically by VTP *only* in unrestricted-membership ELANs. In addition, the ELAN name for VLAN 1 *must* be “default.” For information on configuring the LECS database, see the “Configuring the LECS Database” section on page 3-17.
- Step 5** Bind the LECS database to the ATM interface on the ATM module.
- For information on binding the LECS database to the ATM interface, see the “Binding the LECS to the ATM Interface” section on page 3-23.
- Step 6** At the Catalyst 5000 or 6000 family switch CLI, create the desired VLANs.
- Ensure that the VLAN name matches the ELAN name configured in the LECS database on the ATM module. The name for VLAN 1 is “default” and cannot be changed. The corresponding ELAN name on the ATM module must be “default” also.
- For VTP to successfully set up LECs on all ATM modules in the ATM LANE network, the default VLAN/ELAN must be operational on the ATM modules and Catalyst 5000 or 6000 family switches and must be named “default.” If you currently have a different ELAN name mapped to VLAN 1, you must change the ELAN name to “default” in the LECS database.
- When you enter the **set vlan** command without specifying the VLAN name, the VLAN names listed in Table 3-2 are used by default.

Table 3-2 Default ELAN Names

VLAN Number	ELAN Name
1	default
2	VLAN0002
3	VLAN0003
4	VLAN0004
5	VLAN0005
...1005	...VLAN1005

ATM LANE Configuration Examples

These sections show examples of how to configure ATM LANE on a Catalyst 5000 or 6000 family ATM module:

- Example Configuration 1, page 3-31
- Example Configuration 2, page 3-35
- Example Configuration 3, page 3-39

Example Configuration 1

Figure 3-3 shows two Catalyst 5000 family switches and a LightStream 1010 ATM switch.

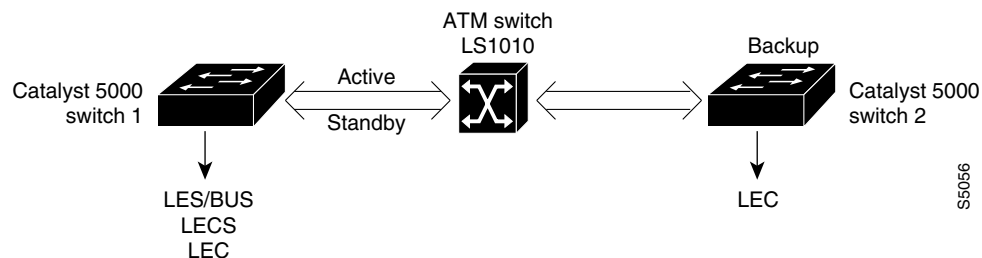
Figure 3-3 LES/BUS/LECS Configuration

Example Configuration 1 Assumptions

In example Configuration 1, these assumptions apply:

- The LightStream 1010 ATM switch is used.
- Catalyst 5000 family switches with the ATM modules installed are running ATM software release 3.1 or later.
- Catalyst 5000 family Switch 1 runs the LES/BUS and LECS on interface atm0 and the LEC on interface atm0.1.

- Catalyst 5000 family Switch 2 runs LEC on interface atm0.1.
- The ATM module is installed in slot 4 of both Catalyst 5000 family switches.
- You can change the ELAN name by entering the **set vlan *vlan_num* [name *elan_name*]** command.
- The ELAN names shown in Table 3-3 are used.

Table 3-3 ELAN Names

VLAN Number	ELAN Name
1	default
2	VLAN0002
3	VLAN0003
4	VLAN0004

Example Configuration 1 Procedure

To set up LANE on the configuration in Table 3-3, perform these steps:

Step 1 Set up the prefix of the ATM Network Service Access Point (NSAP) address for the switch. The LightStream 1010 ATM switch provides a default prefix.

Step 2 Start a session to the ATM module by entering the **session 4** command.

```
Console> session 4
Trying ATM-4...
Connected to ATM-4.
Escape character is '^]'.
ATM>
```

Step 3 Obtain the LES and LES/BUS addresses for later use by entering the **enable** command (to enable configuration mode) and the **show lane default** command at the ATM prompt.

```
ATM>enable
ATM#
ATM#show lane default
interface ATM0:
LANE Client:      47.0091810000000061705b7701.00400BFF0010.**
LANE Server:     47.0091810000000061705b7701.00400BFF0011.**
LANE Bus:        47.0091810000000061705b7701.00400BFF0012.**
LANE Config Server: 47.0091810000000061705b7701.00400BFF0013.00
ATM#
```

**Note**

The two asterisks (**) represent the subinterface number byte in hexadecimal.

- Step 4** Using the LECS address obtained in Step 3, set the address of the default LECS in the LightStream 1010 switch by entering the **configure terminal** and **atm lecs-address atm_address** commands on the console of the LightStream 1010 switch.

```
Switch> enable
Switch#
Switch#configure terminal
Enter configuration commands, one per line. End with CNTL/Z.
Switch(config)#atm lecs-address 47.0091810000000061705b7701.00400BFF0013.00 1
Switch(config)#end
Switch#
```

The commands shown in this step configure the LECS address in the switch. The LECS ATM NSAP address is 47.0091810000000061705b7701.00400BFF0013.00. The sequence number of this LECS address, which is 1, indicates that it is the first LECS in this switch.

- Step 5** Save the configuration as follows:

```
ATM#write memory
```

- Step 6** Start up a LES/BUS pair on Catalyst 5000 family Switch 1 by entering the **interface atm0** and the **lane server-bus ethernet default** commands in configuration mode.

On the console of Switch 1, enter these commands:

```
ATM#configure terminal
Enter configuration commands, one per line. End with CNTL/Z.
ATM(config)#interface atm0
ATM(config-subif)#lane server-bus ethernet default
ATM(config-subif)#end
ATM#
```

The commands shown in this step start a LES/BUS pair. The ELAN name is “default,” and the interface on which this LES/BUS pair is configured is atm0.

- Step 7** Save the configuration as follows:

```
ATM#write memory
```

- Step 8** Set up the LECS database on Switch 1.

Enter the LANE server address obtained in Step 3 and replace the ** with the subinterface number of the interface in which the LES/BUS is to be configured. In this example, that number is 00. Enter the **lane database database_name** command, the **name elan_name server-atm-address atm_address** command, and the **default-name elan_name** commands at the ATM prompt.

```
ATM#configure terminal
Enter configuration commands, one per line. End with CNTL/Z.
ATM(config)#lane database test
ATM(lane-config-database)#name default server-atm-address 47.0091810000000061705b7701.00400BFF0011.00
ATM(lane-config-database)#default-name default
ATM(lane-config-database)#end
ATM#
```

The commands shown in this step create the LECS database. The database name is “test.” The ELAN name is “default.” The LES ATM NSAP address is 47.0091810000000061705b7701.00400BFF0011.00.

- Step 9** Save the configuration as follows:

```
ATM#write memory
```

- Step 10** Start and bind the LECS on Switch 1 by entering the **interface atm0** command, the **lane config database database_name** command, and the **lane config auto-config-atm-address** command at the ATM prompt.

```
ATM#configure terminal
Enter configuration commands, one per line. End with CNTL/Z.
ATM(config)#interface atm0
ATM(config-if)#lane config database test
ATM(config-if)#lane config auto-config-atm-address
ATM(config-if)#end
ATM#
```

The commands shown in this step start the LECS. The database name to use is “test.” The interface on which the LECS is configured is atm0.

- Step 11** Save the configuration as follows:

```
ATM#write memory
```

- Step 12** Start the LEC on Switches 1 and 2 by entering the **interface atm0.1** command and the **lane client ethernet 1 default** command in configuration mode on the consoles of the switches. The interface on which the LEC is configured is atm0.1. The ELAN name is “default,” and it is configured to emulate Ethernet.

```
ATM#configure terminal
Enter configuration commands, one per line. End with CNTL/Z.
ATM(config)#interface atm0.1
ATM(config-subif)#lane client ethernet 1 default
ATM(config-subif)#end
ATM#
```

- Step 13** Save the configuration as follows:

```
ATM#write memory
```

- Step 14** Create a LES/BUS pair on Switch 1 for VLAN 2 by entering the **interface atm0.2** command and the **lane server-bus ethernet VLAN0002** command in configuration mode.

```
ATM#configure terminal
Enter configuration commands, one per line. End with CNTL/Z.
ATM(config-subif)#interface atm0.2
ATM(config-subif)#lane server-bus ethernet VLAN0002
ATM(config-subif)#end
ATM#
```

- Step 15** Save the configuration as follows:

```
ATM#write memory
```

- Step 16** Configure the address of the new LES/BUS pair in the LECS database on Switch 1 by entering the **lane database test** command and the **name VLAN0002 server-atm-address atm_address** command in configuration mode.

```
ATM#configure terminal
ATM(config)#lane database test
ATM(lane-config-database)#name VLAN0002 server-atm-address 47.0091810000000061705b7701.00400BFF0011.02
ATM(lane-config-database)#end
ATM#
```

- Step 17** Save the configuration as follows:

```
ATM#write memory
```

- Step 18** Start the new LEC on Switch 2 by entering the **interface atm0.2** command and the **lane client ethernet 2 VLAN0002** command in configuration mode.

```
ATM#configure terminal
Enter configuration commands, one per line. End with CNTL/Z.
ATM(config)#interface atm0.2
ATM(config-subif)#lane client ethernet 2 VLAN0002
ATM(config-subif)#end
ATM#
```

- Step 19** Save the configuration as follows:

```
ATM#write memory
```

Example Configuration 2

Figure 3-4 shows three Catalyst 5000 family switches (Catalyst 5000 family Switch 1, Switch 2, and Switch 3) and a LightStream 1010 ATM switch. LES/BUS/LECS redundancy is configured. Switches 1 and 2 both have one LES/BUS/LECS for every ELAN. Switch 1 is the master server, and Switch 2 is the backup server. If Switch 1 fails, Switch 2 provides the LES/BUS/LECS components of the ELAN. When switch 1 recovers, it becomes the master server again.

Figure 3-4 LES/BUS/LECS Redundancy

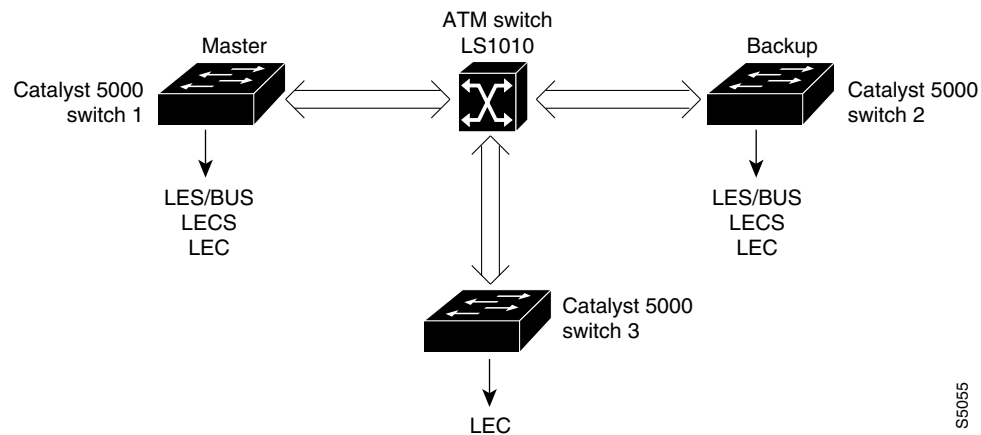

S5055

Example Configuration 2 Assumptions

In Figure 3-4, these assumptions apply:

- Catalyst 5000 family Switch 1 is the master. It runs the LES/BUS and LECS on interface atm0 and runs the LEC on interface atm0.1.
- Catalyst 5000 family Switch 2 is the backup server. It runs LES/BUS and LECS on interface atm0 and runs the LEC on interface atm0.1.

- Catalyst 5000 family Switch 3 runs the LEC on interface atm0.1.
- The ATM module is installed in slot 4 of each Catalyst 5000 family switch.

Example Configuration 2 Procedure

To set up the configuration in Figure 3-4, perform these steps:

Step 1 Set up the prefix of the ATM NSAP address for the switch.

The LightStream 1010 ATM switch provides a default prefix.

Step 2 Establish a connection with the ATM module from Switch 1 by entering the **session** command.

```
Console> session 4
Trying ATM-4...
Connected to ATM-4.
Escape character is '^]'.
```

Step 3 Obtain the LES and LES/BUS addresses for later use by entering the **show lane default** command.

```
ATM>show lane default
interface ATM0:
LANE Client:      47.0091810000000061705b7701.00400BFF0010.**
LANE Server:     47.0091810000000061705b7701.00400BFF0011.**
LANE Bus:        47.0091810000000061705b7701.00400BFF0012.**
LANE Config Server: 47.0091810000000061705b7701.00400BFF0013.00
ATM>
```



Note The two asterisks (**) represent the subinterface number byte displayed in hexadecimal.

Step 4 Establish a connection to the ATM module from Switch 2 by entering the **session** command.

```
Console> session 4
Trying ATM-4...
Connected to ATM-4.
Escape character is '^]'.
```

Step 5 Obtain the LES and LES/BUS addresses for later use by entering the **show lane default** command from privileged mode.

```
ATM>
ATM>enable
ATM#
ATM#show lane default
interface ATM0:
LANE Client:      47.0091810000000061705b7701.00400B583040.**
LANE Server:     47.0091810000000061705b7701.00400B583041.**
LANE Bus:        47.0091810000000061705b7701.00400B583042.**
LANE Config Server: 47.0091810000000061705b7701.00400B583043.00
ATM#
```



Note The two asterisks (**) represent the subinterface number byte displayed in hexadecimal.

Step 6 Set up the LECS database on Switches 1 and 2. Enter the LES addresses obtained in Steps 3 and 5 and replace the two asterisks (**) with the subinterface numbers of the interfaces in which the LES/BUS is to be configured. In this example, that number is 00. Enter the **lane database database-name** command, the **name elan_name server-atm-address atm_address** command, and the **default-name elan_name** commands in configuration mode on both Switch 1 and Switch 2.

**Note**

The order of the entries is critical and should be the same on both the primary and secondary Catalyst 5000 family switches for this configuration to work effectively.

Enter the following commands:

```
ATM#configure terminal
Enter configuration commands, one per line. End with CNTL/Z.
ATM(config)#lane database test
ATM(lane-config-database)#name default server-atm-address
47.0091810000000061705b7701.00400BFF0011.00
ATM(lane-config-database)#name default server-atm-address
47.0091810000000061705b7701.00400B583041.00
ATM(lane-config-database)#default-name default
ATM(lane-config-database)#end
ATM#
```

In this example, the name of the database is “test.” The name of the ELAN is “default.” The first entry is the primary LES. The second entry is the backup LES. The primary LES ATM NSAP address is 47.0091810000000061705b7701.00400BFF0011.00. The backup LES ATM NSAP address is 47.0091810000000061705b7701.00400B583041.00.

Step 7 Save the configuration as follows:

```
ATM#write memory
```

Step 8 Start and bind the LECS on both Switches 1 and 2 by entering the **interface atm0** command, the **lane config database database_name** command, and the **lane config auto-config-atm-address** command in configuration mode on both Switch 1 and Switch 2.

```
ATM#configure terminal
Enter configuration commands, one per line. End with CNTL/Z.
ATM(config)#interface atm0
ATM(config-if)#lane config test
ATM(config-if)#lane config auto-config-atm-address
ATM(config-if)#end
ATM#
```

In this example, the database name is “test” and the interface on which the LECS is configured is atm0.

Step 9 Save the configuration as follows:

```
ATM#write memory
```

Step 10 Start up a LES/BUS pair on Switch 1 and Switch 2 by entering the **interface atm0** command and the **lane server-bus ethernet default** command on the console of both switches.

```
ATM#configure terminal
Enter configuration commands, one per line. End with CNTL/Z.
ATM(config)#interface atm0
ATM(config-subif)#lane server-bus ethernet default
ATM(config-subif)#end
ATM#
```

In this example, the ELAN name is “default” and the interface on which this LES/BUS pair is configured is atm0.

Step 11 Save the configuration as follows:

```
ATM#write memory
```

- Step 12** Set the LECS addresses on Switches 1 and 2 in the ATM switch by entering the **atm lecs-address atm_address** command in configuration mode on the console of the LightStream 1010 switch for each Catalyst 5000 family switch.

These commands configure the address of the primary and the backup LECSs in the ATM switch, in the order presented on the screen. Enter the LANE configuration server address obtained in Steps 3 and 5.

```
ATM>enable
ATM#configure terminal
Enter configuration commands, one per line. End with CNTL/Z.
ATM(config)#atm lecs-address 47.0091810000000061705b7701.00400BFF0013.00 1
ATM(config)#atm lecs-address 47.0091810000000061705b7701.00400B583043.00 2
ATM(config)#end
ATM#
```

- Step 13** Save the configuration as follows:

```
ATM#write memory
```

- Step 14** Start the LEC on Switches 1, 2, and 3 by entering the **interface atm0.1** command and the **lane client ethernet 1 default** command in configuration mode on the consoles of Switches 1, 2, and 3.

```
ATM#configure terminal
Enter configuration commands, one per line. End with CNTL/Z.
ATM(config)#interface atm0.1
ATM(config-subif)#lane client ethernet 1 default
ATM(config-subif)#end
ATM#
```

The interface on which the LEC is configured is atm0.1. The ELAN name is default, and it is configured to emulate Ethernet.

- Step 15** Save the configuration as follows:

```
ATM#write memory
```



Note

To use VTP to create the LEC, see the “Creating LECs Automatically Using VTP” section on page 3-29.

- Step 16** Create a LES/BUS pair on switches 1 and 2 for VLAN 2. Enter the **interface atm0.2** command and the **lane server-bus ethernet VLAN 0002** command in configuration mode on the consoles of Switches 1 and 2.

```
ATM#configure terminal
Enter configuration commands, one per line. End with CNTL/Z.
ATM(config-subif)#interface atm0.2
ATM(config-subif)#lane server-bus ethernet VLAN0002
ATM(config-subif)#end
ATM#
```

- Step 17** Save the configuration as follows:

```
ATM#write memory
```

Step 18 Configure the address of the new LES/BUS pair in the LECS database on Switch 1:

```
ATM#configure terminal
ATM(config)#lane database test
ATM(lane-config-database)#name VLAN0002 server-atm-address
47.009181000000061705b7701.00400BFF0011.02
ATM(lane-config-database)#name VLAN0002 server-atm-address
47.009181000000061705b7701.00400B583041.02
ATM(lane-config-database)#end
ATM#
```

Step 19 Save the configuration as follows:

```
ATM#write memory
```

Step 20 Start the new LEC on Switch 3 by entering the **interface atm0.2** command and the **lane client ethernet 2 VLAN0002** command on the console of Switch 3.

```
ATM#configure terminal
Enter configuration commands, one per line. End with CNTL/Z.
ATM(config)#interface atm0.2
ATM(config-subif)#lane client ethernet 2 VLAN0002
ATM(config-subif)#end
ATM#
```

Step 21 Save the configuration as follows:

```
ATM#write memory
```

Example Configuration 3

Figure 3-5 shows two ATM switches in an ATM cloud. ATM Switch 1 is connected to two Catalyst 5000 family switches (Catalyst 5000 family Switch 1 and Catalyst 5000 family Switch 2), which have ATM dual PHY modules. ATM Switch 2 is also connected to Catalyst 5000 family Switch 1 and Catalyst 5000 family Switch 2. If PHY A on Catalyst 5000 family Switch 1 is lost, data continues to flow to Catalyst 5000 family Switch 2 on PHY B, showing dual PHY redundancy.

Figure 3-5 LES/BUS/LECS Redundancy with Dual PHYs

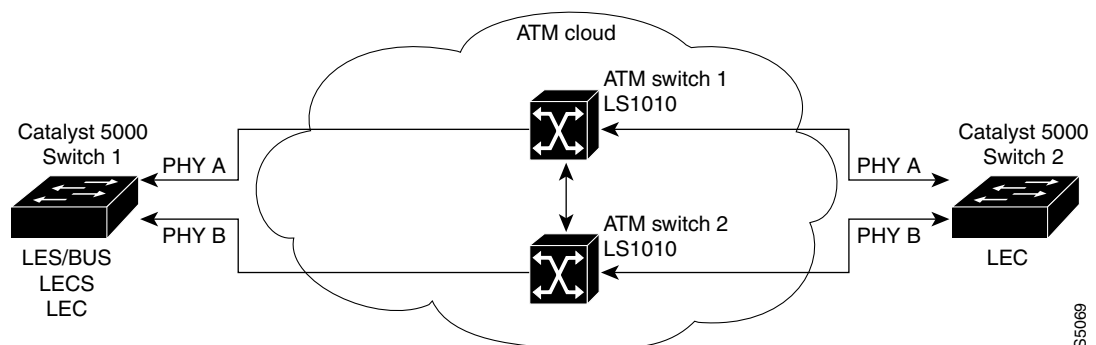

55069

Example Configuration 3 Assumptions

In Figure 3-5, these assumptions apply:

- The LightStream 1010 switch is used.
- Catalyst 5000 family switches with the ATM modules installed are running ATM software release 3.1 or later.
- Catalyst 5000 family Switch 1 runs the LECS on interface atm0.
- Catalyst 5000 family Switch 1 runs the LES/BUS and LEC for VLAN/ELAN1 on interface atm0.1.
- Catalyst 5000 family Switch 1 runs the LES/BUS and LEC for VLAN/ELAN 2 on subinterface atm0.2.
- Catalyst 5000 family Switch 2 runs the LEC for ELAN/VLAN 1 on interface atm0.1.
- Catalyst 5000 family Switch 2 runs the LEC for ELAN/VLAN 2 on interface atm0.2.
- The ATM module is installed in slot 4 of the Catalyst 5000 family switches.
- You can change the ELAN name by entering the **set vlan** *vlan_num* [*name*] command.

Example Configuration 3 Procedure

To set up LANE on the configuration in Figure 3-5, perform these steps:

-
- Step 1** Set up the prefix of the ATM NSAP address for the switch.
- The LightStream 1010 ATM switch provides a default prefix.
- Step 2** Establish a connection to the ATM module by entering the **session** command at the Catalyst 5000 family switch console prompt.
- ```
Console> session 4
Trying ATM-4...
Connected to ATM-4.
Escape character is '^]'.

```
- Step 3** Obtain the LECS and LES/BUS addresses for later use by entering the **show lane default** command in privileged mode at the ATM prompt.
- ```
ATM>enable
ATM#
ATM#show lane default
interface ATM0:
LANE Client:      47.0091810000000061705b7701.00400BFF0010.**
LANE Server:     47.0091810000000061705b7701.00400BFF0011.**
LANE Bus:        47.0091810000000061705b7701.00400BFF0012.**
LANE Config Server: 47.0091810000000061705b7701.00400BFF0013.00
ATM#

```



Note

The two asterisks (**) represent the subinterface number byte displayed in hexadecimal.

- Step 4** Access path B by entering the **interface atm0** and the **atm preferred phy B** commands in configuration mode.

```
ATM#configure terminal
Enter configuration commands, one per line. End with CNTL/Z.
ATM(config)#interface atm0
ATM(config-subif)#atm preferred phy B
ATM(config-subif)#end
ATM#
```

Wait for approximately one minute while the PHY B comes up.

- Step 5** Enter the **show lane default** command. The two asterisks (**) represent the subinterface number byte displayed in hexadecimal.

```
ATM#show lane default
interface ATM0:
LANE Client:      47.0091810000000061705b8301.00400BFF0010.**
LANE Server:     47.0091810000000061705b8301.00400BFF0011.**
LANE Bus:        47.0091810000000061705b8301.00400BFF0012.**
LANE Config Server: 47.0091810000000061705b8301.00400BFF0013.00
ATM#
```

- Step 6** Return to PHY A by entering the **interface atm0** and the **atm preferred phy A** commands in configuration mode.

```
ATM#configure terminal
Enter configuration commands, one per line. End with CNTL/Z.
ATM(config)#interface atm0
ATM(config-subif)#atm preferred phy A
ATM(config-subif)#end
ATM#
```

- Step 7** Set the address of the default LECS in the ATM switches by entering the addresses from Steps 3 and 5. Enter the **atm lecs-address atm_address** command on the console of the LightStream 1010 Switch 1. These commands configure the address of the primary and the backup LECSs in the ATM switches in the specific order entered. Only one LECS runs on the Catalyst 5000 family Switch 1, but the address (the first 13 bytes) changes if PHY B is used instead of PHY A.

```
ATM>enable
ATM#configure terminal
Enter configuration commands, one per line. End with CNTL/Z.
ATM(config)#atm lecs-address 47.0091810000000061705b7701.00400BFF0013.00 1
ATM(config)#atm lecs-address 47.0091810000000061705b8301.00400BFF0013.00 2
ATM(config)#end
ATM#
```

- Step 8** Save the configuration as follows:

```
ATM#write memory
```

- Step 9** Enter the **interface atm0** and **lane server-bus ethernet default** commands in configuration mode on the console of Catalyst 5000 family Switch 1. These commands start a LES/BUS pair. The ELAN name is “default.” The interface on which this LES/BUS pair is configured is atm0.

```
ATM#configure terminal
Enter configuration commands, one per line. End with CNTL/Z.
ATM(config)#interface atm0
ATM(config-subif)#lane server-bus ethernet default
ATM(config-subif)#end
ATM#
```

Step 10 Save the configuration as follows:

```
ATM#write memory
```

Step 11 Configure the LECS database of the Catalyst 5000 family Switch 1 by entering the **lane database database_name** command, the **name elan_name server-atm-address atm address** command, and the **default-name elan_name** command.

```
ATM#configure terminal
Enter configuration commands, one per line. End with CNTL/Z.
ATM(config)#lane database test
ATM(lane-config-database)#name default server-atm-address
47.0091810000000061705b7701.00400BFF0011.00
ATM(lane-config-database)#name default server-atm-address
47.0091810000000061705b8301.00400BFF0011.00
ATM(lane-config-database)#default-name default
ATM(lane-config-database)#end
ATM#
```

Enter the LANE server addresses from Steps 3 and 5. Replace the two asterisks (**) with the subinterface number of the interface in which the LES/BUS is to be configured. In this example, the number is 00. These commands create the LECS database. The name of the database is test. The name of the ELAN is “default.”

The ATM NSAP address of the LES is 47.0091810000000061705b7701.00400BFF0011.00. The display in Step 3 shows this LANE BUS address.

The ATM NSAP address of the LES is 47.0091810000000061705b8301.00400BFF0011.00. The display in Step 5 shows this LANE BUS address.

Step 12 Save the configuration as follows:

```
ATM#write memory
```

Step 13 Start and bind the LECS on the Catalyst 5000 family Switch 1 by entering the **interface atm0** command, the **lane config database database_name** command, and the **lane config auto-config-atm-address** command in configuration mode at the ATM prompt. The database name is “test.” The interface on which the LECS is configured is atm0.

```
ATM#configure terminal
Enter configuration commands, one per line. End with CNTL/Z.
ATM(config)#interface atm0
ATM(config-if)#lane config test
ATM(config-if)#lane config auto-config-atm-address
ATM(config-if)#end
ATM#
```

Step 14 Save the configuration as follows:

```
ATM#write memory
```

Step 15 Start a LEC on Catalyst 5000 family Switches 1 and 2 by entering the **interface atm0.1** and **lane client ethernet 1 default** commands in configuration mode on the consoles of each Catalyst 5000 family switch. The interface on which the LEC is configured is atm0.1. The ELAN name is default, and it is configured to emulate Ethernet.

```
ATM#configure terminal
Enter configuration commands, one per line. End with CNTL/Z.
ATM(config)#interface atm0.1
ATM(config-subif)#lane client ethernet 1 default
ATM(config-subif)#end
ATM#
```

Step 16 Save the configuration as follows:

```
ATM#write memory
```

Step 17 Create a LES/BUS pair on the Catalyst family Switch 1 for VLAN 2 by entering the **interface atm0.2** and **lane server-bus ethernet VLAN0002** commands in configuration mode.

```
ATM#configure terminal
Enter configuration commands, one per line. End with CNTL/Z.
ATM(config)#interface atm0.2
ATM(config-subif)#lane server-bus ethernet VLAN0002
ATM(config-subif)#end
ATM#
```

Step 18 Save the configuration as follows:

```
ATM#write memory
```

Step 19 Configure the address of the new LES/BUS pair in the LECS database on the Catalyst 5000 family Switch 1 by entering the **lane database database_name** and **name elan_name server-atm-address atm_address** commands in configuration mode.

```
ATM#configure terminal
ATM(config)#lane database test
ATM(lane-config-database)#name VLAN0002 server-atm-address 47.0091810000000061705b7701.00400BFF0011.02
ATM(lane-config-database)#name VLAN0002 server-atm-address 47.0091810000000061705b8301.00400BFF0011.02
ATM(lane-config-database)#end
ATM#
```

Step 20 Save the configuration as follows:

```
ATM#write memory
```

Step 21 Start the new LEC on the Catalyst 5000 family Switch 2 by entering the **interface atm0.2** and **lane client ethernet 2 VLAN0002** commands in configuration mode on the console of Catalyst 5000 family Switch 2.

```
ATM#configure terminal
Enter configuration commands, one per line. End with CNTL/Z.
ATM(config)#interface atm0.2
ATM(config-subif)#lane client ethernet 2 VLAN0002
ATM(config-subif)#end
ATM#
```

Step 22 Save the configuration as follows:

```
ATM#write memory
```

Understanding LANE QoS

LANE quality of service (QoS) is supported on the following platforms:

- Catalyst 6000 family ATM OC-12 modules (WS-X6101-OC12-SMF, WS-X6101-OC12-MMF)
- Catalyst 5000 family dual-PHY OC-12 ATM LANE/Multiprotocol over ATM (MPOA) modules (WS-X5161, WS-X-5162)

**Note**

The Catalyst 5000 family ATM modules currently do not support LANE QoS. Support for the LANE QoS feature will be added in a future release.

LANE QoS provides the capability to differentiate multiple classes of traffic. This is achieved by creating (multiple) VCCs with the desired QoS parameters. When the prioritized traffic is received, the LEC forwards it on a VCC with matching QoS parameters.

Currently, LANE QoS supports the creation of unspecified bit rate+ (UBR+) VCCs. A UBR+ VCC is a UBR VCC for which minimum cell rate (MCR) is guaranteed by the switch. If the switch cannot guarantee the rate you have specified for the UBR+ VCC, the LANE client will revert to UBR with no MCR guarantee.

You can enable or disable the LANE QoS feature on a per LEC basis by entering the **qos** option in the **lane client** command. The same ELAN can contain both QoS-capable and non-QoS capable LECs.

**Note**

If a QoS VCC setup is rejected due to insufficient resources at the switch, the VCC setup falls back to UBR VCC.

Packet Classification

On the Catalyst 6000 ATM platform, the routed packet is classified by the class of service (CoS) value before it is handed over to the LANE. The LEC determines the VCC based on the packets CoS. CoS to VCC mapping is determined by the user configuration. Non-IP traffic and bridged traffic streams are always sent over the UBR+ VCC.

In the Catalyst 5000 family ATM modules, the LEC creates either a UBR+ VCC or UBR VCC, but not both. A UBR+ VCC is created by specifying the QoS parameters for the ATM address of the remote LEC.

Restrictions

These restrictions apply to the LANE QoS feature on the Catalyst 5000 and 6000 ATM modules:

- LANE QoS is supported on devices with matching UBR+ VCC parameters. If the remote NSAP is not configured for QoS, the VCC setup falls back to UBR VCC.
- If a QoS VCC setup is rejected because of insufficient resources at the switch, the VCC setup reverts to UBR VCC.
- On Catalyst 5000 ATM modules, creation of multiple VCCs is not supported.
- LANE QoS is supported only with version 2-compliant LANE client software.

Configuring LANE QoS

Before you can configuring LANE QoS, you must define a LANE QoS database using the **lane qos database name** command.

To configure LANE QoS, perform the following task:

Task	Command
Step 1	Enter the UBR+ VCC parameters for the destination NSAP address.
Step 2	Map the CoS value or range of values to a UBR+ VCC.
Step 3	Apply the LANE QoS database to an interface.
Step 4	Verify the configuration.

Configuring LANE QoS on a Catalyst 5000 Family ATM Module

In this example, a UBR+ VCC is established with the network services access point (NSAP) address of 47.0091810000000061705B0C01.00E0B0951A40.0A. All traffic destined for this address is sent on the created UBR+ VCC.

```

ATM# configure terminal
Enter configuration commands, one per line. End with CNTL/Z.
ATM(config)# lane qos database fred
ATM(lane-qos)# atm-address 47.0091810000000061705B0C01.00E0B0951A40.0A cos 7 pcr 500000
mcr 100000
ATM(lane-qos)# exit
ATM(config)# interface atm0.2
ATM(config-subif)# lane client qos fred
ATM(config-subif)# end
ATM# show lane qos database fred
QoS: fred
    configured cos values: 4-7, usage: 1
    dst nsap: 47.0091810000000061705B0C01.00E0B0951A40.0A
    cos: 7, pcr: 500000, mcr: 100000
ATM#

```

Configuring LANE QoS Modes on a Catalyst 5000 Family ATM Module

On Catalyst 5000 family switches, incoming packets can be classified based on such Layer 2 QoS information as the MAC address, VLAN port, or the input port, but this classification information cannot be transmitted to the UBR or UBR+ VCC on the Catalyst 5000 ATM module.

However, the LANE QoS-capable Catalyst 5000 ATM modules can forward traffic based on the IP Precedence setting. To enable the ATM modules to forward traffic based on IP Precedence, you must configure LANE QoS for trusted mode.



Note

The trusted mode only works for traffic that enters the Catalyst 5000 family switch with the IP Precedence bits already set by an external device. The Catalyst 5000 family switch itself is not able to assign IP Precedence.

The Catalyst 5000 ATM LANE QoS feature supports the following two modes:

- **Untrusted Mode**—In this mode, packets are sent to a UBR+ VC based on the configured NSAP address. This mode is used for all incoming traffic, except for traffic that has the IP Precedence field set.

- **Trusted Mode**—In this mode, packets are forwarded to the UBR or UBR+ VC based on the IP Precedence field in the packet's IP header.

The default mode is untrusted mode. To change the command mode to trusted mode, enter the **lane qos iptos trust** command in global configuration mode.

To revert to untrusted mode, enter the **no lane qos iptos trust** command in global configuration mode.

This example shows that the command mode is changed to trusted:

```
ATM(config)# lane qos iptos trust
```

This example shows that the command mode is changed to untrusted:

```
ATM(config)# no lane qos iptos trust
```

Enter the **show running configuration** command to view the command mode setting.

Configuring LANE QoS on a Catalyst 6000 ATM Module

This example shows how to configure LANE QoS on a Catalyst 6000 ATM module. A UBR+ VCC is established with the NSAP address 47.0091810000000061705B0C01.00E0B0962B50.0A in addition to the already created UBR VCC with the same NSAP. All traffic destined to the configured NSAP and matching CoS range 5 to 7 is sent over the UBR+ VCC. The remainder of the traffic is sent over the default UBR VCC.

```
ATM# configure terminal
Enter configuration commands, one per line. End with CNTL/Z.
ATM(config)# lane qos database bob
ATM(lane-qos)# atm-address 47.0091810000000061705B0C01.00E0B0962B50.0A ubr+ pcr 500000
mcr 100000
ATM(lane-qos)# ubr+ cos 5-7
ATM(lane-qos)# exit
ATM(config)# interface atm0.2
ATM(config-subif)# lane client qos bob
ATM(config-subif)# end
```

Monitoring and Maintaining LANE QoS

To monitor the LANE QoS configurations and settings, perform one of these tasks:

Task	Command
<ul style="list-style-type: none"> • Display the contents of a specific LANE QoS database. 	show lane qos database <i>[name]</i>
<ul style="list-style-type: none"> • Display the contents of the le-arp table, including the type of VCC. 	show lane le-arp
<ul style="list-style-type: none"> • Display the contents of the le-arp table, including the VCD value of each CoS. 	show lane le-arp qos