



Catalyst 6500 Series Supervisor Engine 1A DRAM Upgrade Installation Note

Part Number: MEM-S1-128MB=

The MEM-S1-128MB= memory upgrade kit consists of 2 64-MB dynamic random-access memory (DRAM) dual inline memory modules (DIMMs). The memory upgrade kit upgrades the total supervisor engine memory from 64 MB (2 32-MB DIMMs) to 128 MB (2 64-MB DIMMs).

This publication describes how to remove and install the DRAM DIMMs on the following Catalyst 6500 series supervisor engines:

- WS-X6K-S1A-MSFC2
- WS-X6K-SUP1A-PFC
- WS-X6K-SUP1A-2GE



Note The WS-X6K-SUP1A-2GE shipped since June 2004 has 128 MB installed as default. Enter the **show version mod** command to display the total DRAM installed on the supervisor engine.

- WS-X6K-SUP1A-MSFC—See the following Note statements for information about the MEM-S1-128MB-UPG= upgrade kit for the WS-X6K-SUP1A-MSFC.



Note

With the exception of WS-X6K-SUP1A-MSFC, all other Supervisor Engine 1A modules can upgrade to 128-MB DRAM using the MEM-S1-128MB= upgrade kit. To upgrade to 128-MB DRAM on the WS-X6K-SUP1A-MSFC, use the MEM-S1-128MB-UPG= upgrade kit *which also includes* an MSFC2 upgrade.



Note

The DRAM DIMMs on the Supervisor Engine 1A with an MSFC (WS-X6K-SUP1A-MSFC) are located beneath the MSFC. The MSFC is not field replaceable. Re-installing the MSFC could damage your supervisor engine. To upgrade the DRAM, you must also upgrade the MSFC to an MSFC2. Both upgrades are available in the MEM-S1-128MB-UPG= upgrade kit.

For information on removing the MSFC, refer to the *Catalyst 6500 Series Multilayer Switch Feature Card 2 Installation Note* at this URL:

http://www.cisco.com/en/US/docs/switches/lan/catalyst6500/hardware/Config_Notes/78_10605.html

Contents

This publication consists of these sections:

- [Memory Recommendations and Requirements, page 2](#)
- [Safety Overview, page 3](#)
- [Required Tools, page 3](#)
- [Removing the MSFC2, page 4](#)
- [Upgrading the DRAM DIMM, page 8](#)
- [Installing the MSFC2, page 10](#)
- [Related Documentation, page 15](#)
- [Obtaining Documentation and Submitting a Service Request, page 15](#)

Memory Recommendations and Requirements

See [Table 1](#) for memory recommendations and requirements.

Table 1 *Memory Recommendations and Requirements*

Catalyst Software Release	Memory Recommendation/Requirement
6.x	With Catalyst software releases 6.x, your Supervisor Engine 1A configuration is fully supported with 64-MB DRAM.
7.x	With software releases 7.5(1) and later, 64-MB DRAM may not provide adequate free memory for all configurations. With large, existing configurations using many features, or when enabling new features available in release 7.5 and later, 64-MB DRAM might not be enough memory. We recommend upgrading to 128-MB DRAM to ensure that adequate free memory is available to the system at all times.
	Software release 7.6(4) and later 7.6(x) releases are too large to fit in the 64-MB DRAM that originally shipped on some Supervisor Engine 1A modules. You must upgrade to 128-MB DRAM.
8.x	With Catalyst software releases 8.1(1) and later, your Supervisor Engine 1A configuration requires 128-MB DRAM.

**Caution**

The supervisor engine is a required system component. If only one supervisor engine is present, removing it while the system is operating causes the system to halt.

Safety Overview

Safety warnings appear throughout this publication in procedures that may harm you if performed incorrectly. A warning symbol precedes each warning statement.

**Warning****IMPORTANT SAFETY INSTRUCTIONS**

This warning symbol means danger. You are in a situation that could cause bodily injury. Before you work on any equipment, be aware of the hazards involved with electrical circuitry and be familiar with standard practices for preventing accidents. Use the statement number provided at the end of each warning to locate its translation in the translated safety warnings that accompanied this device. Statement 1071

SAVE THESE INSTRUCTIONS**Warning**

Only trained and qualified personnel should be allowed to install, replace, or service this equipment. Statement 1030

**Warning**

Hazardous voltage or energy is present on the backplane when the system is operating. Use caution when servicing. Statement 1034

**Warning**

Blank faceplates and cover panels serve three important functions: they prevent exposure to hazardous voltages and currents inside the chassis; they contain electromagnetic interference (EMI) that might disrupt other equipment; and they direct the flow of cooling air through the chassis. Do not operate the system unless all cards, faceplates, front covers, and rear covers are in place. Statement 1029

Required Tools

These tools are required to upgrade the supervisor engine DRAM:

- Antistatic mat or foam pad to support the removed supervisor engine
- 3/16-inch flat-blade screwdriver for the captive installation screws on the supervisor engine
- Number 1 Phillips-head screwdriver for the screws and cap nut that fasten the MSFC2 to the supervisor engine (if an MSFC2 is installed on the supervisor engine)
- Your own ESD-prevention equipment or the disposable grounding wrist strap included with all upgrade kits, field-replaceable units (FRUs), and spares

Refer to the *Catalyst 6500 Series Switch Installation Guide* for the locations of the ESD connectors on the Catalyst 6500 series switches.

Removing the MSFC2



Note

If upgrading a supervisor engine without an MSFC2 (WS-X6K-SUP1A-PFC or WS-X6K-SUP1A-2GE), proceed to the [“Upgrading the DRAM DIMM”](#) section on [page 8](#) to install the DRAM.

**Note**

The DRAM DIMMs on the Supervisor Engine 1A with an MSFC (WS-X6K-SUP1A-MSFC) are located beneath the MSFC. The MSFC is not field replaceable. Re-installing the MSFC could damage your supervisor engine. To upgrade the DRAM, you must also upgrade the MSFC to an MSFC2. Both upgrades are available in the MEM-S1-128MB-UPG= upgrade kit.

For information on removing the MSFC, refer to the *Catalyst 6500 Series Multilayer Switch Feature Card 2 Installation Note* at this URL:

http://www.cisco.com/en/US/docs/switches/lan/catalyst6500/hardware/Config_Notes/78_10605.html

**Caution**

Always use an ESD wrist strap when handling modules or coming into contact with internal components.

Before you remove the supervisor engine, you should first upload the current configuration to a server. You can recover the configuration by downloading it from the server to the nonvolatile memory of the supervisor engine. For more information, refer to Chapter 26, “Working with Configuration Files,” in the *Catalyst 6500 Series Software Configuration Guide*.

The DRAM is located beneath the MSFC2. To upgrade the supervisor engine, you must remove the MSFC2 from the supervisor engine.

To remove the MSFC2 from the supervisor engine, follow these steps:

- Step 1** Upload the current configuration to a server. On any modules running Cisco IOS software, save the running configuration.
- Step 2** Remove the supervisor engine from the Catalyst 6500 series switch. (Refer to the *Catalyst 6500 Series Module Installation Guide* for removal instructions.)
- Step 3** Place the supervisor engine on an antistatic mat or foam.
- Step 4** Remove the securing screws and cap nut that secure the MSFC2 to the supervisor engine. (See [Figure 1](#) for an MSFC2 shipped before November 2001, or see [Figure 2](#) for an MSFC2 shipped after November 2001.)

**Note**

The MSFC2 shipped after November 2001 is physically smaller than the previous MSFC2 and is not secured with a cap nut. (See [Figure 2](#).)

Figure 1 MSFC2 Shipped Before November 2001—Removing Securing Screws and Cap Nut

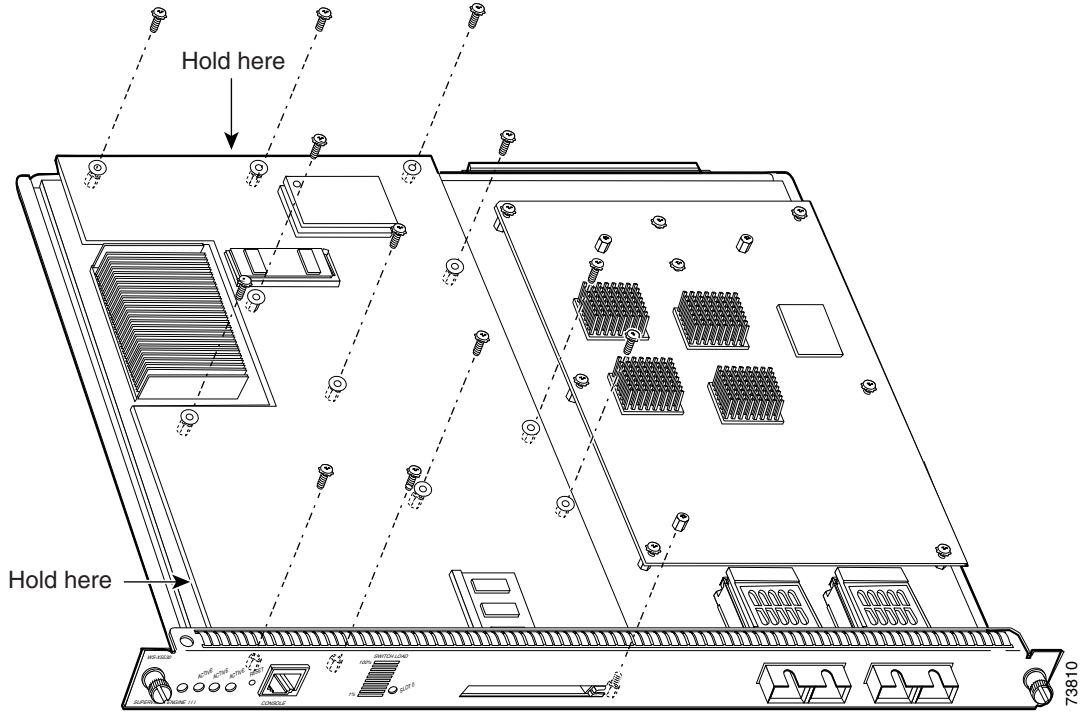
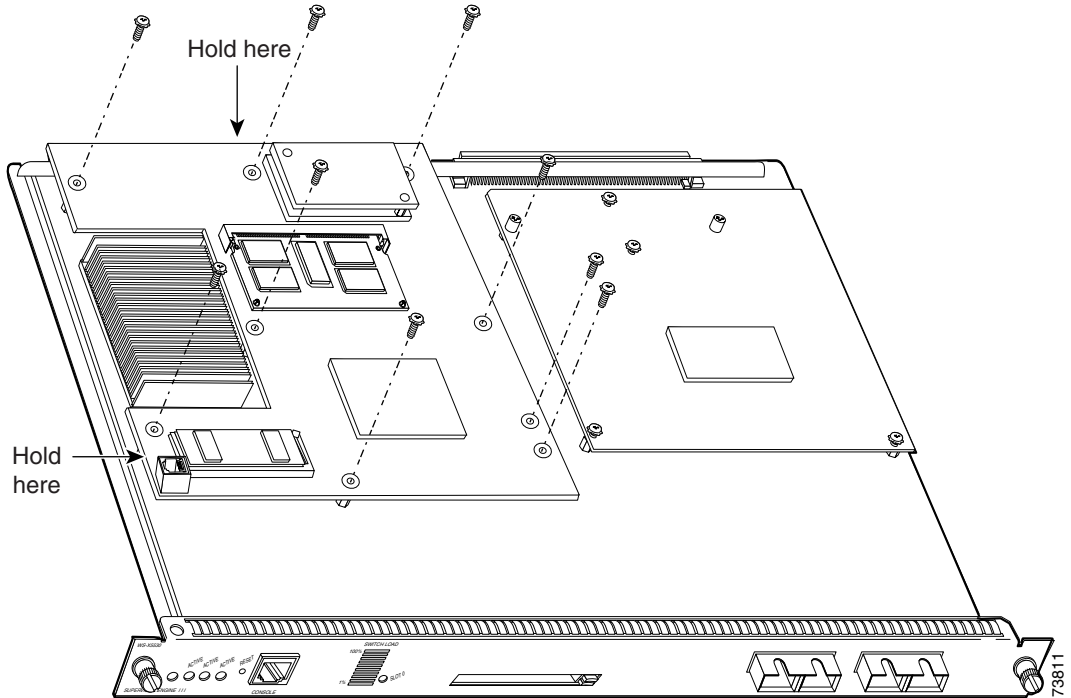

Figure 2 MSFC2 Shipped After November 2001—Removing Securing Screws



- Step 5** Hold the top edge of the MSFC2 with your right hand and the bottom-left edge with your left hand. (See [Figure 1](#) for an MSFC2 shipped before November 2001 or [Figure 2](#) for an MSFC2 shipped after November 2001.) Gently lift the MSFC2 with both hands simultaneously, and remove the MSFC2 from the supervisor engine.



Caution Use care not to damage the connectors on the supervisor engine. If you damage a connector, you will have to return the supervisor engine to Cisco for repair.

- Step 6** Place the MSFC2 on an antistatic mat or antistatic foam pad.

Proceed to the [“Upgrading the DRAM DIMM”](#) section on page 8 to install the DRAM.

Upgrading the DRAM DIMM



Warning

During this procedure, wear grounding wrist straps to avoid ESD damage to the card. Do not directly touch the backplane with your hand or any metal tool, or you could shock yourself.

This section describes how to remove the existing DIMMs and replace them with the upgrade DIMMs. The DRAM DIMM location is shown in [Figure 3](#).



Note

The Supervisor Engine 1A DRAM uses two DIMMs, one stacked on top of the other.

Figure 3 DRAM Location

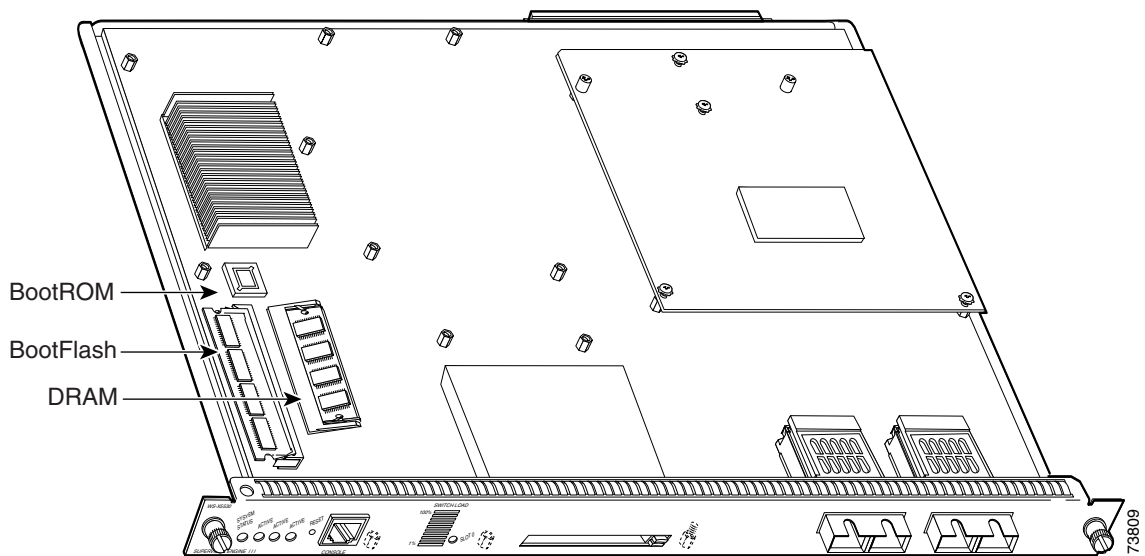

Caution

Always use an ESD wrist strap when handling modules or coming into contact with internal components.

To install the DRAM upgrade, follow these steps:

Step 1

Remove the DRAM DIMMs from the socket by pulling the locking spring clips on both sides of the DIMM holder outward, and tilt the DIMM free of the clips. (See [Figure 4](#).) Be careful not to break the clips on the DIMM connector.



Note

The Supervisor Engine 1A DRAM uses two DIMMs, one stacked on top of the other. Remove the upper DIMM first, and then remove the lower DIMM.

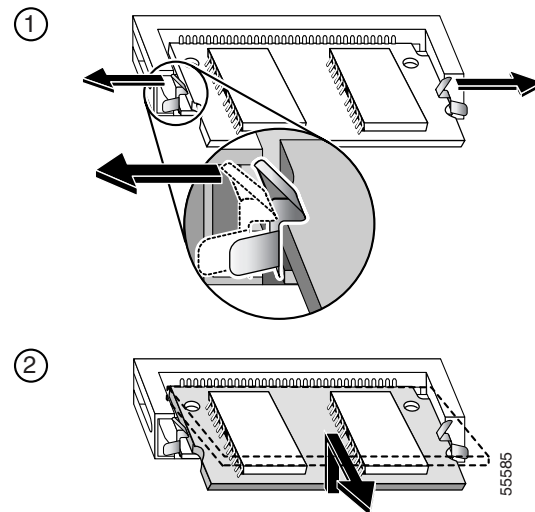
Figure 4 Removing the DRAM DIMM

- Step 2** Hold the DIMM by its edges, gently lift and remove it, and place it on an antistatic mat or foam. (See [Figure 5](#).)

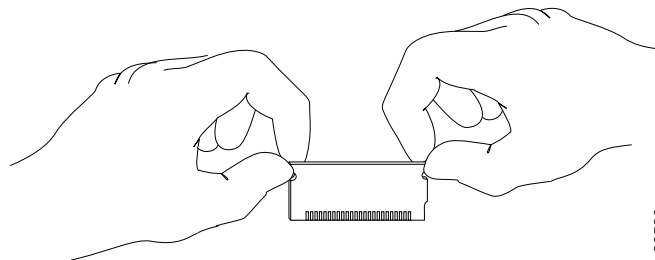
Figure 5 Handling a DIMM**Caution**

DIMMs are sensitive components that are susceptible to ESD damage. To prevent ESD damage, handle DIMMs by the edges only; avoid touching the memory modules, pins, or traces (the metal *fingers* along the connector edge of the DIMM). (See [Figure 5](#).)

- Step 3** Remove one upgrade DIMM from the antistatic container.

- Step 4** Hold the DIMM by its edges. (See [Figure 5](#).)

- Step 5** Tilt the DIMM to approximately the same angle as the socket, and insert the connector edge into the socket. Note the notch (key) on the right connector edge of the DIMM. (See [Figure 5](#).) This key assures correct orientation of the DIMM in the socket.

**Note**

The Supervisor Engine 1A DRAM uses two DIMMs, one stacked on top of the other. Install the lower DIMM first.

**Caution**

When inserting the DIMM, use firm but not excessive pressure. If you damage a socket, you will have to return the supervisor engine to Cisco for repair.

- Step 6** Press the DIMM down until it is secured by the spring clips. (See [Figure 6](#).)

Figure 6 *Installing the DIMM*

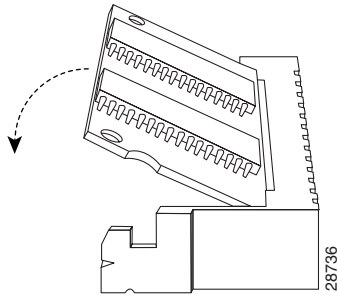

- Step 7** When the DIMM is installed, check the two alignment holes and ensure that the spring retainer is visible. If it is not, the DIMM is not seated properly. If the DIMM appears misaligned, carefully remove it and reseat it in the socket. Push the DIMM firmly back into the socket until the retainer springs snap into place.
- Step 8** Repeat [Step 3](#) through [Step 7](#) for the second (upper) DIMM.

Installing the MSFC2



Note The MSFC2 that shipped after November 2001 is physically smaller than the previous MSFC2.

To install the MSFC2 on the supervisor engine, follow these steps:

- Step 1** Align the MSFC2 with the standoffs on the supervisor engine. The MSFC2 shipped before November 2001 will also align with the male standoff. (See [Figure 7](#).) Make sure that the remaining mounting holes on the MSFC2 are aligned with the remaining standoffs.

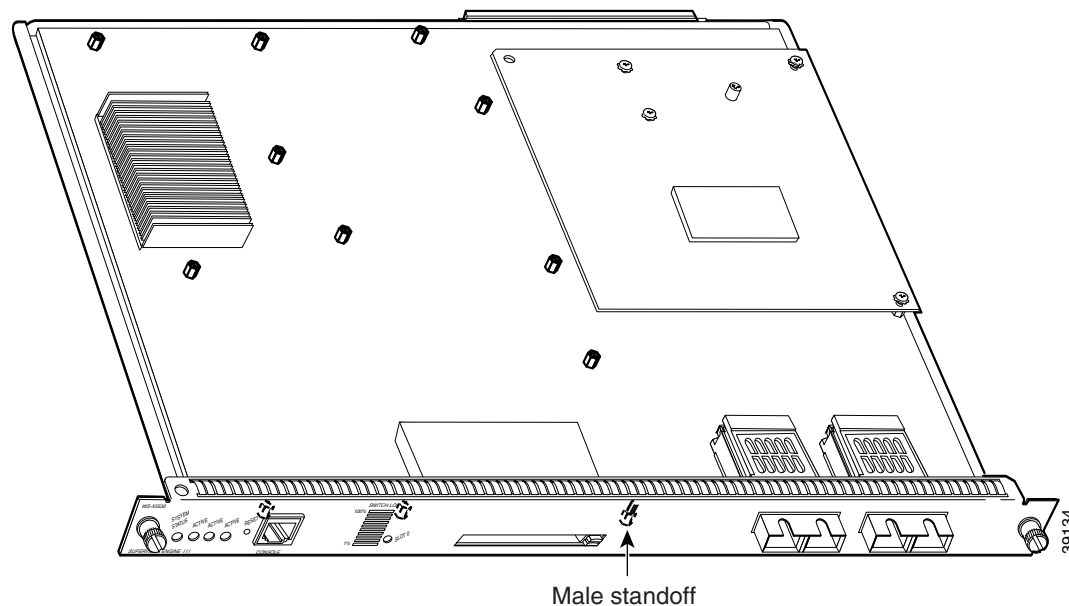
Figure 7 Male Standoff Location on the Supervisor Engine

- Step 2** Ensure that the connectors on the MSFC2 (see [Figure 8](#)) are aligned with the connectors on the supervisor engine.

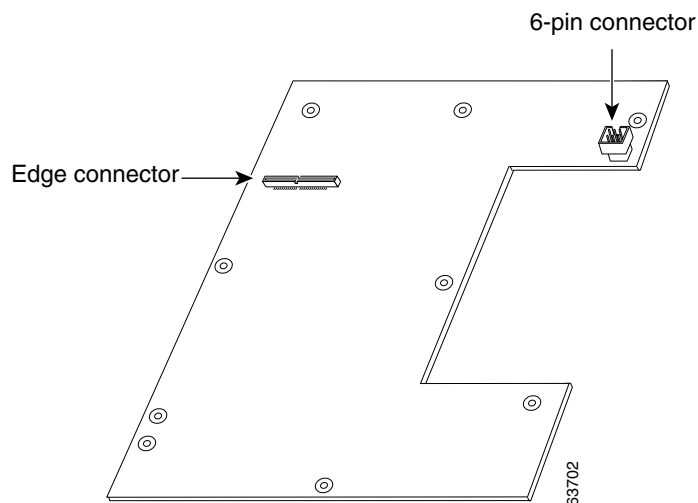
Figure 8 MSFC2 Connectors

- Step 3** Carefully seat the MSFC2 onto the supervisor engine. (See [Figure 9](#) for an MSFC2 shipped before November 2001 or [Figure 10](#) for an MSFC2 shipped after November 2001.)
- Step 4** Using your thumbs, apply pressure at the connector locations (shown in [Figure 9](#) for an MSFC2 shipped before November 2001 or [Figure 10](#) for an MSFC2 shipped after November 2001) to ensure that the MSFC2 is securely seated on the supervisor engine.

Caution

Use care not to damage the connectors on the supervisor engine. If you damage a connector, you will have to return the supervisor engine to Cisco for repair.

Figure 9 MSFC2 Shipped Before November 2001—Seating on the Supervisor Engine 1A

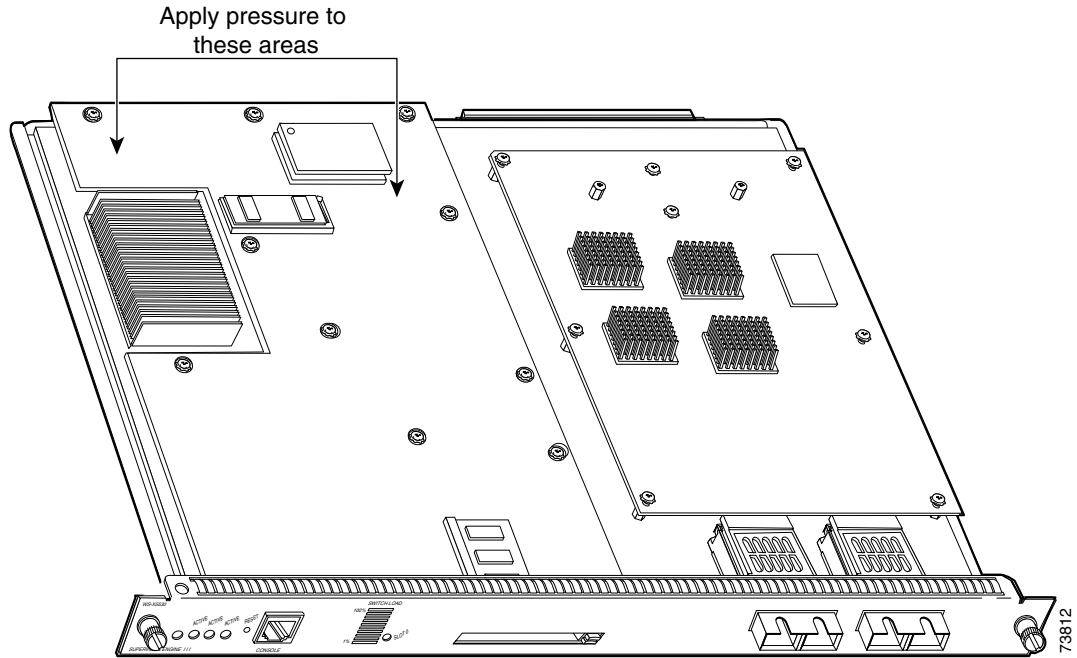
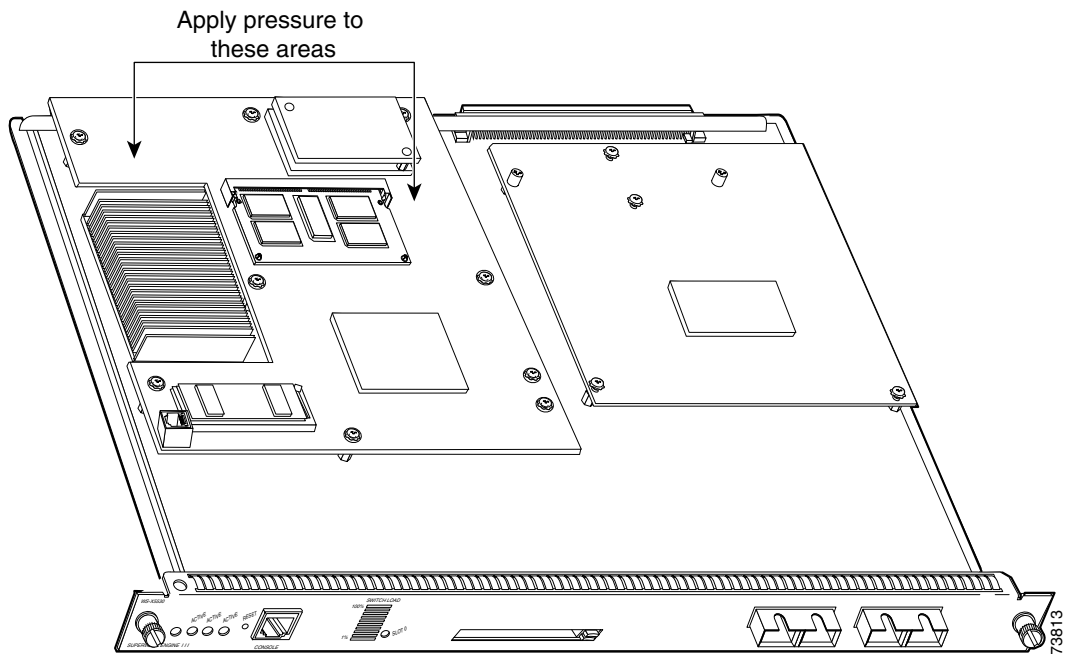

Figure 10 MSFC2 Shipped After November 2001—Seating on the Supervisor Engine 1A



**Caution**

Ensure that the MSFC2 is securely seated before you install and tighten the securing screws. Using the screws to seat the MSFC2 could warp the card.

Step 5

Use a Phillips-head screwdriver to install the screws and cap nut (if applicable) that secure the MSFC2 to the supervisor engine. (See [Figure 11](#) for an MSFC2 that shipped before November 2001, or [Figure 12](#) for an MSFC2 shipped after November 2001.)

**Caution**

You *must* install the cap nut (if applicable) and all screws. The screws provide grounding between the MSFC2 and the supervisor engine. Failure to install the cap nut and all screws will invalidate the safety approvals and can cause fire and electrical hazards.

Figure 11 MSFC2 Shipped Before November 2001—Installing the Securing Screws and Cap Nut

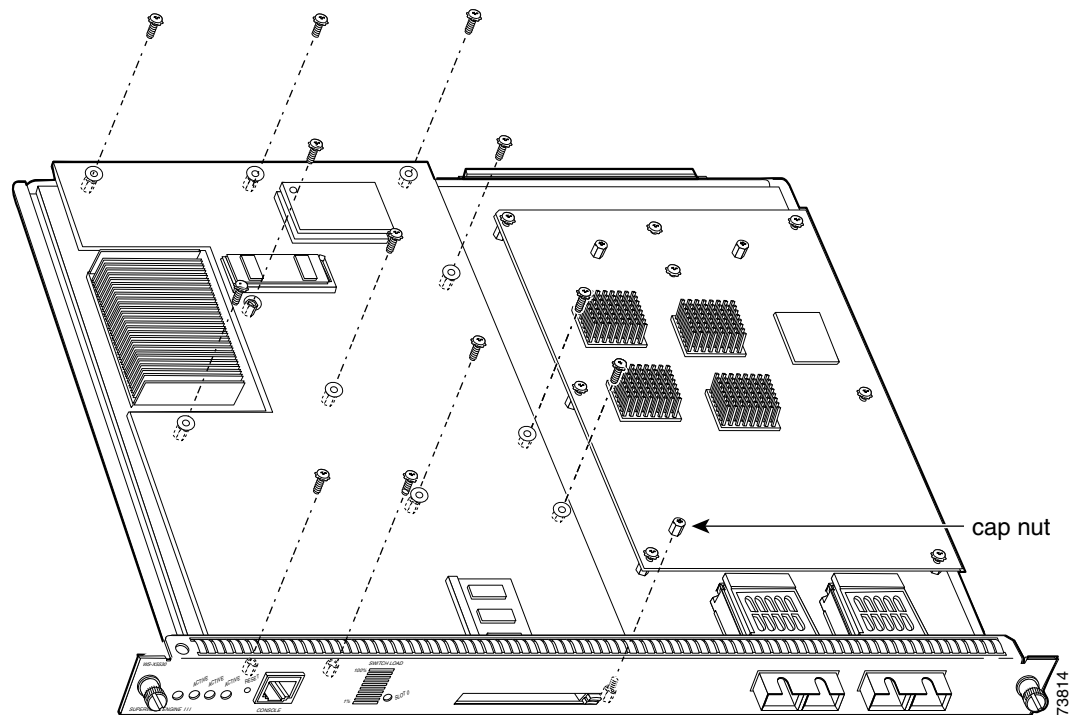
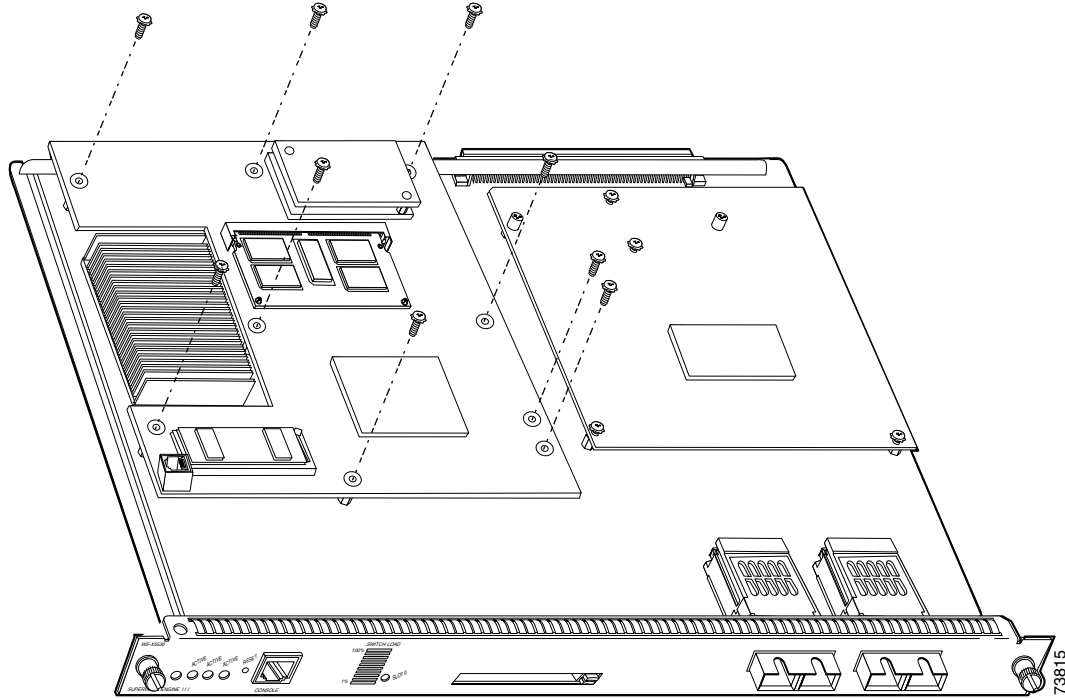

Figure 12 MSFC2 Shipped After November 2001—Installing the Securing Screws



Step 6 Install the supervisor engine in the Catalyst 6500 series switch. (Refer to the *Catalyst 6500 Series Module Installation Guide* for installation instructions.)



Note Verify that the supervisor engine STATUS LED is lit. If the STATUS LED changes from orange to green, the supervisor engine has successfully completed the boot process and is now online. If the STATUS LED remains orange or turns red, the supervisor engine has not successfully completed the boot process and may have encountered an error.



Note If the LEDs on the supervisor engine front panel are red, remove the supervisor engine, carefully remove the DIMMs, and reseal the DIMMs in the socket. Push the DIMMs firmly back into the socket until the retainer springs snap into place.

If you have redundant supervisor engines, return to [Step 2](#) in the “[Removing the MSFC2](#)” section on [page 4](#), and follow the directions to upgrade the redundant supervisor engine.

Step 7 Enter the **show version** command to verify the amount of memory on the supervisor engine.

This example shows that the total memory is 128 MB on the supervisor engine:

```
Console> show version
...<output truncated>
```

Module	DRAM			FLASH			NVRAM		
	Total	Used	Free	Total	Used	Free	Total	Used	Free
2	130944K	57916K	73028K	16384K	12003K	4381K	512K	257K	255K

```
Console>
```

Related Documentation

For additional information on Catalyst 6500 series switches and command-line interface (CLI) commands, refer to the following publications:

- *Regulatory Compliance and Safety Information for the Catalyst 6500 Series Switches*
- *Catalyst 6500 Series Switch Installation Guide*
- *Catalyst 6500 Series Switch Module Installation Guide*
- *Catalyst 6500 Series Switch Software Configuration Guide*
- *Catalyst 6500 Series Switch Command Reference*
- *Catalyst 6500 Series Switch IOS Software Configuration Guide*
- *Catalyst 6500 Series Switch IOS Command Reference*

Obtaining Documentation and Submitting a Service Request

For information on obtaining documentation, submitting a service request, and gathering additional information, see the monthly *What's New in Cisco Product Documentation*, which also lists all new and revised Cisco technical documentation, at:

<http://www.cisco.com/en/US/docs/general/whatsnew/whatsnew.html>

Subscribe to the *What's New in Cisco Product Documentation* as a Really Simple Syndication (RSS) feed and set content to be delivered directly to your desktop using a reader application. The RSS feeds are a free service and Cisco currently supports RSS Version 2.0.

This document is to be used in conjunction with the documents listed in the “[Related Documentation](#)” section.

CCVP, the Cisco logo, and Welcome to the Human Network are trademarks of Cisco Systems, Inc.; Changing the Way We Work, Live, Play, and Learn is a service mark of Cisco Systems, Inc.; and Access Registrar, Aironet, Catalyst, CCDA, CCDP, CCIE, CCIP, CCNA, CCNP, CCSP, Cisco, the Cisco Certified Internetwork Expert logo, Cisco IOS, Cisco Press, Cisco Systems, Cisco Systems Capital, the Cisco Systems logo, Cisco Unity, Enterprise/Solver, EtherChannel, EtherFast, EtherSwitch, Fast Step, Follow Me Browsing, FormShare, GigaDrive, HomeLink, Internet Quotient, IOS, iPhone, IP/TV, iQ Expertise, the iQ logo, iQ Net Readiness Scorecard, iQuick Study, LightStream, Linksys, MeetingPlace, MGX, Networkers, Networking Academy, Network Registrar, PIX, ProConnect, ScriptShare, SMARTnet, StackWise, The Fastest Way to Increase Your Internet Quotient, and TransPath are registered trademarks of Cisco Systems, Inc. and/or its affiliates in the United States and certain other countries.

All other trademarks mentioned in this document or Website are the property of their respective owners. The use of the word partner does not imply a partnership relationship between Cisco and any other company. (0711R)

Copyright © 2002–2003 Cisco Systems, Inc. All rights reserved.