



Catalyst Family Inline-Power Patch Panel Installation and Verification Note

Part Number: WS-PWR-PANEL

This document describes the Catalyst family inline-power patch panel and includes rack-mounting and cabling procedures.

The inline-power patch panel will work with any Cisco 10/100 Mbps switching product capable of supporting IP telephones.

Contents

This document consists of these sections:

- Overview, page 2
- Front Panel Description, page 2
- Safety Overview, page 3
- Installing the Inline-Power Patch Panel, page 5
- Cabling, page 7
- Verifying the Installation, page 8
- Specifications and Agency Approvals, page 8
- Translated Safety Warnings, page 10
- Related Documentation, page 12
- Obtaining Documentation, page 12
- Obtaining Technical Assistance, page 13



Overview

Typically, LAN-based IP telephones use external power converters located at or near the desktop. The inline-power patch panel eliminates the need for external power sources; it is a standalone chassis that can be co-located with the Catalyst switch to provide -48 VDC power directly to the telephone through *existing* Catalyst family 10/100BaseTX switching modules. When used with an uninterruptible power supply (UPS), the inline-power patch panel can provide power to the telephone even in a power failure.

The inline-power patch panel has 48 RJ-45 input ports and 48 RJ-45 output ports (see Figure 1). There are two RJ-45 connectors per port for a total of 48 ports. Each input connector is internally connected to a corresponding output connector (input connector 1 is connected to output connector 1, and so on).

The RJ-45 ports serve as the physical network interfaces to the inline-power patch panel. The lower bank of ports provide 10/100-Mbps connection to the switch through RJ-45 connector pins 1, 2, 3, and 6. The top bank of ports provide -48 VDC power to the IP telephones through RJ-45 connector pins 4, 5, 7, and 8, in addition to transparently passing 10/100 Mbps data traffic on pins 1, 2, 3, and 6.

Front Panel Description

This section describes the front-panel features of the inline-power patch panel:

- 48 RJ-45 *client* ports for connecting to IP telephones
- 48 RJ-45 *switch* ports for connecting to 10/100BaseTX switch ports
- Unit status LED (see Table 1)
- Port status LED (see Table 2)
- AC-input connector
- ESD receptacle

Figure 1 *Inline Power Patch Panel Front Panel*

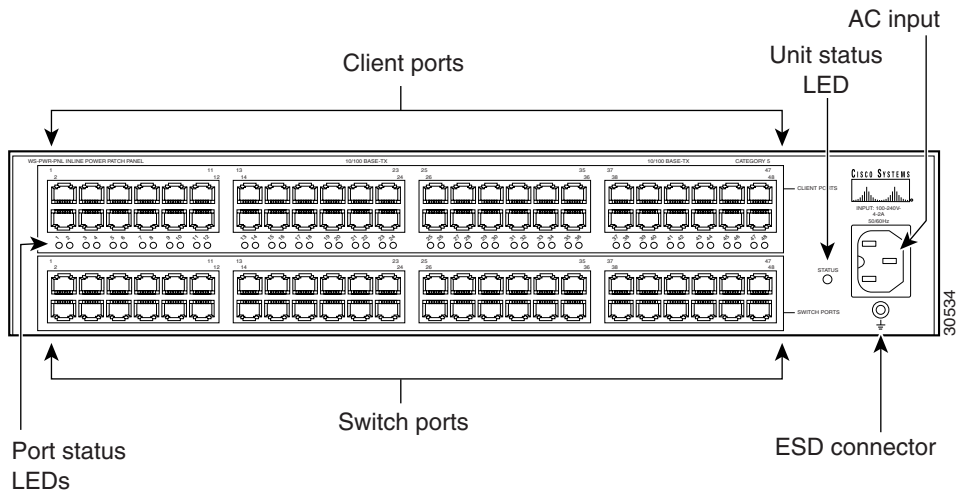

Table 1 Unit Status LED Description

Color	Description
Green	Power successfully applied to all ports.
Red	Power problem on one or more ports.
Off	No AC-input power to inline-power patch panel.

Table 2 Port Status LED Description

Color	Description
Green	Power successfully applied to port.
Flashing Green and Amber	Power problem on the port.
Amber	Power not applied to the port.
Off	No AC-input power to inline-power patch panel.

Safety Overview

Safety warnings appear throughout this note in procedures that, if performed incorrectly, might harm you. A warning symbol precedes each warning statement. This section describes the warning symbol used in this note.



Warning

This warning symbol means danger. You are in a situation that could cause bodily injury. Before you work on any equipment, be aware of the hazards involved with electrical circuitry and be familiar with standard practices for preventing accidents. (To see translations of the warnings that appear in this publication, refer to the appendix, "Translated Safety Warnings.")

Waarschuwing

Dit waarschuwingssymbool betekent gevaar. U verkeert in een situatie die lichamelijk letsel kan veroorzaken. Voordat u aan enige apparatuur gaat werken, dient u zich bewust te zijn van de bij elektrische schakelingen betrokken risico's en dient u op de hoogte te zijn van standaard maatregelen om ongelukken te voorkomen. (Voor vertalingen van de waarschuwingen die in deze publicatie verschijnen, kunt u het aanhangsel "Translated Safety Warnings" (Vertalingen van veiligheidsvoorschriften) raadplegen.)

Varoitus

Tämä varoitusmerkki merkitsee vaaraa. Olet tilanteessa, joka voi johtaa ruumiinvammaan. Ennen kuin työskentelet minkään laitteiston parissa, ota selvää sähkökytkentöihin liittyvistä vaaroista ja tavanomaisista onnettomuuksien ehkäisykeinoista. (Tässä julkaisussa esiintyvien varoitusten käännökset löydät liitteestä "Translated Safety Warnings" (käännetyt turvallisuutta koskevat varoitukset).)

Attention	Ce symbole d'avertissement indique un danger. Vous vous trouvez dans une situation pouvant entraîner des blessures. Avant d'accéder à cet équipement, soyez conscient des dangers posés par les circuits électriques et familiarisez-vous avec les procédures courantes de prévention des accidents. Pour obtenir les traductions des mises en garde figurant dans cette publication, veuillez consulter l'annexe intitulée « Translated Safety Warnings » (Traduction des avis de sécurité).
Warnung	Dieses Warnsymbol bedeutet Gefahr. Sie befinden sich in einer Situation, die zu einer Körperverletzung führen könnte. Bevor Sie mit der Arbeit an irgendeinem Gerät beginnen, seien Sie sich der mit elektrischen Stromkreisen verbundenen Gefahren und der Standardpraktiken zur Vermeidung von Unfällen bewusst. (Übersetzungen der in dieser Veröffentlichung enthaltenen Warnhinweise finden Sie im Anhang mit dem Titel "Translated Safety Warnings" (Übersetzung der Warnhinweise).)
Avvertenza	Questo simbolo di avvertenza indica un pericolo. Si è in una situazione che può causare infortuni. Prima di lavorare su qualsiasi apparecchiatura, occorre conoscere i pericoli relativi ai circuiti elettrici ed essere al corrente delle pratiche standard per la prevenzione di incidenti. La traduzione delle avvertenze riportate in questa pubblicazione si trova nell'appendice, "Translated Safety Warnings" (Traduzione delle avvertenze di sicurezza).
Advarsel	Dette varselsymboler betyr fare. Du befinner deg i en situasjon som kan føre til personskade. Før du utfører arbeid på utstyr, må du være oppmerksom på de faremomentene som elektriske kretser innebærer, samt gjøre deg kjent med vanlig praksis når det gjelder å unngå ulykker. (Hvis du vil se oversettelser av de advarslene som finnes i denne publikasjonen, kan du se i vedlegget "Translated Safety Warnings" [Oversatte sikkerhetsadvarsler].)
Aviso	Este símbolo de aviso indica perigo. Encontra-se numa situação que lhe poderá causar danos físicos. Antes de começar a trabalhar com qualquer equipamento, familiarize-se com os perigos relacionados com circuitos eléctricos, e com quaisquer práticas comuns que possam prevenir possíveis acidentes. (Para ver as traduções dos avisos que constam desta publicação, consulte o apêndice "Translated Safety Warnings" - "Traduções dos Avisos de Segurança").
Advertencia	Este símbolo de aviso significa peligro. Existe riesgo para su integridad física. Antes de manipular cualquier equipo, considerar los riesgos que entraña la corriente eléctrica y familiarizarse con los procedimientos estándar de prevención de accidentes. (Para ver traducciones de las advertencias que aparecen en esta publicación, consultar el apéndice titulado "Translated Safety Warnings.")
Varning!	Denna varningssymbol signalerar fara. Du befinner dig i en situation som kan leda till personskada. Innan du utför arbete på någon utrustning måste du vara medveten om farorna med elkretsar och känna till vanligt förfarande för att förebygga skador. (Se förklaringar av de varningar som förekommer i denna publikation i appendix "Translated Safety Warnings" [Översatta säkerhetsvarningar].)

Installing the Inline-Power Patch Panel

This section provides rack-mounting instructions for the inline-power patch panel.



Note

This unit requires 3.5 inches (8.9 cm) of rack-mounting space.

A rack-mount kit is included for mounting the inline-power patch panel in a standard 19-inch (48.3 cm) equipment rack with two unobstructed outer posts, with a minimum depth (between the front and rear mounting posts) of 19.25 inches (48.9 cm) and a maximum depth of 32 inches (81.3 cm). This kit is not suitable for racks with obstructions (such as a power strip) that could impair access to the inline-power patch panel.



Warning

Before you install, operate, or service the system, read the *Site Preparation and Safety Guide*. This guide contains important safety information you should know before working with the system.

Required Tools

The following tools and equipment are required to install the chassis:

- Number 1, number 2 Phillips, or 3/16-inch flat-blade screwdriver
- Antistatic mat or antistatic foam
- Your own electrostatic discharge (ESD) grounding strap or the disposable ESD strap included with the system



Note

For more information about ESD, refer to the *Site Preparation and Safety Guide*.

The following tools and equipment are required to install the chassis in a rack:

- Rack-mount kit
- Tape measure and level

Rack-Mounting Procedure

Use this procedure to install the inline-power patch panel in a rack.



Caution

During this procedure, wear grounding wrist straps to avoid ESD damage to the unit.

Step 1

Prepare for installation as follows:

- a. Place the inline-power patch panel on the floor or on a sturdy table as close as possible to the rack. Leave enough clearance to allow you to move around the chassis.
- b. Use a tape measure to measure the depth of the rack. Measure from the outside of the front mounting posts to the outside of the rear mounting strip. The depth must be at least 19.25 inches (48.9 cm) but not greater than 32 inches (81.3 cm).

- c. Measure the space between the inner edges of the left front and right front mounting posts to ensure that it is 17.75 inches (45.09 cm) wide. (The chassis is 17.5 inches [44 cm] wide and must fit between the mounting posts.)
- d. Open the rack-mount kit and see the component checklist in Table 3 to verify that all parts are included.

Table 3 Rack-Mount Kit Checklist

Quantity	Part Description
2	L brackets
4	M4 Phillips pan-head screws
4	12-24 x 3/4-inch Phillips binder-head screws



Note Figure 2 illustrates how to attach the front of the inline-power patch panel to the rack. You can also attach the rear of the inline-power patch panel to the rack, depending on the configuration of your rack.

Step 2 Note that the L brackets connect the chassis to the rack. You can mount the L brackets to the front or rear mounting holes of the chassis, depending on which end is in the front of the rack.



Note Some equipment racks provide a power strip along the length of one of the rear posts. If the rack has this feature, consider the position of the strip when planning fastener points. Before installing the L brackets on the chassis, determine whether to install the chassis from the front or the rear of the rack.

Attach the left and right L brackets using the four M4 Phillips pan-head screws provided in the rack-mount kit (see Figure 2).

Figure 2 Attaching the L Brackets

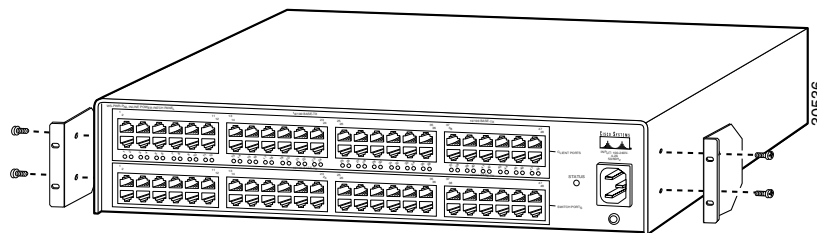

- Step 3** Install the chassis in the rack as follows:
- a. Position the chassis in the rack as follows (see Figure 3):
 - If the chassis front panel is in the front of the rack, insert the rear of the chassis between the mounting posts
 - If the rear of the chassis is in the front of the rack, insert the front of the chassis between the mounting posts
 - b. Align the mounting holes in the L bracket with the mounting holes in the equipment rack.

- c. Secure the chassis using six (three per side) 12-24 x 3/4-inch screws through the elongated holes in the L bracket and into the threaded holes in the mounting post.
- d. Use a tape measure and level to ensure that the chassis is installed straight and level.

Figure 3 Installing the Inline-Power Patch Panel in the Rack

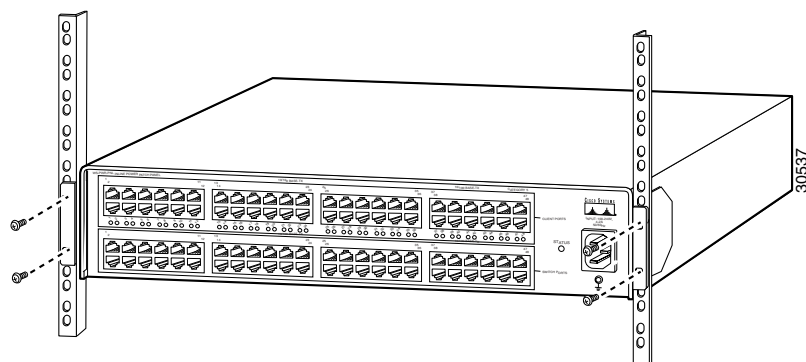

The inline-power patch panel powers up when you connect the chassis power cord.

Cabling

This section provides cabling guidelines for connecting the inline-power patch panel to the Catalyst switch and IP telephones.



Warning

To avoid electric shock, do not connect safety extra-low voltage (SELV) circuits to telephone-network voltage (TNV) circuits. LAN ports contain SELV circuits, and WAN ports contain TNV circuits. Some LAN and WAN ports both use RJ-45 connectors. Use caution when connecting cables.



Note

The inline-power patch panel should only be used to provide power to IP telephones, not 10/100 adapters. If the IP telephone has a power source, you can attach the telephone directly to the 10/100BaseTX port on the Catalyst switch. However, if the IP telephone has a local power source, the inline-power patch panel provides backup power when the local power fails or is removed.

Use these guidelines for your cabling connections (see Figure 4):

- Use standard Category 3 or Category 5 UTP cable.
- Connect a cable from the IP telephone to an RJ-45 port in the top bank of ports.
- Connect a second cable to the corresponding RJ-45 port in the lower bank of ports, and then connect the other end of this cable to a 10/100BaseTX port on the Catalyst switch.

Figure 4 Connecting an IP Telephone to the Inline-Power Patch Panel

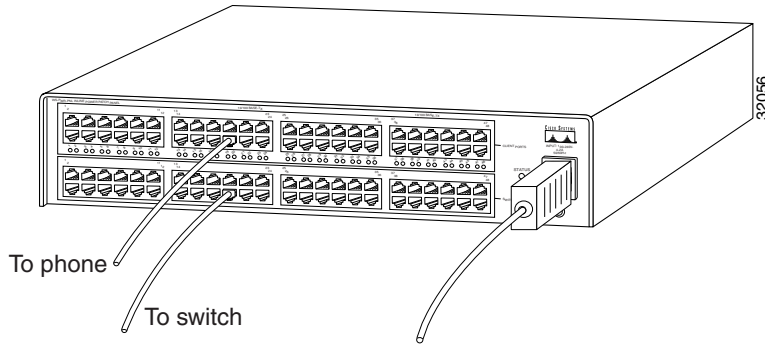

Verifying the Installation

- Before connecting the cables, verify that all the port LEDs are amber and the status LED is green.
- After connecting the cables from the inline-power patch panel to the Catalyst switch and IP telephone, verify that the port LED and status LED are both green.
- Verify the link on the switch through the inline-power patch panel to the telephone.
- Verify that the IP telephone powers up and the screen displays “Cisco Systems.”

Specifications and Agency Approvals

See Table 4 for the technical specifications and agency approvals for the inline-power patch panel.

Table 4 Specifications and Agency Approvals

Item	Specification
Environmental	
Temperature, ambient operating	32°F (0°C) to 104°F (40°C)
Temperature, ambient nonoperating and storage	–40°F (–40°C) to 185°F (85°C)
Humidity (RH), ambient (noncondensing) operating	10% to 90%
Humidity (RH), ambient (noncondensing) nonoperating and storage	5% to 95%
Altitude, operating and nonoperating	Operating: –500 ft. (–152 m) to 10,000 ft. (3050 m) Nonoperating: –1000 ft. (–304 m) to 50,000 ft. (15,240 m)
Physical Characteristics	
Dimensions (H x W x D)	3.4 in. x 17.2 in. x 12 in.
Weight	12 lb (5.4 kg)
Power	
AC-input voltage	85 to 264 VAC

Table 4 Specifications and Agency Approvals (continued)

Item	Specification
AC frequency	47 to 63 Hz
AC current	4A at 100 VAC 2A at 240 VAC
Airflow	200 linear ft per minute, right to left
System Power Dissipation	330W
System KVA Rating	0.34 KVA
System Heat Dissipation	1125 BTU/hr (chassis and phones) 400 BTU/hr (chassis only)
Agency Approvals Compliance	CE ² Marking
Safety	UL ³ 1950, CSA ⁴ -C22.2 No. 950, EN ⁵ 60950, IEC ⁶ 60950, AS/NZS ⁷ 3260
EMC¹	FCC ⁸ Part 15 (CFR ⁹ 47) Class A, ICES ¹⁰ -003 Class A, EN55022 Class A, CISPR22 Class A, AS/NZS 3548 Class A, and VCCI Class A with UTP ¹¹ cables EN55022 Class B, CISPR22 Class B, AS/NZS 3548 Class B, and VCCI ¹² Class B with FTP ¹³ cables

1. EMC = electromagnetic compatibility.
2. CE = European Compliance.
3. UL = Underwriters Laboratory.
4. CSA = Canadian Standards Association.
5. EN = European Norm.
6. IEC = International Electrotechnical Commission.
7. AS/NZS = Standards Australia/Standards New Zealand.
8. FCC = Federal Communications Commission.
9. CFR = Code of Federal Regulations.
10. ICES = Interference-Causing Equipment Standard.
11. UTP = unshielded twisted-pair.
12. VCCI = Voluntary Control Council for Information Technology Equipment.
13. FTP = foil twisted-pair.

Translated Safety Warnings

Warning

Before you install, operate, or service the system, read the Site Preparation and Safety Guide. This guide contains important safety information you should know before working with the system.

Waarschuwing

Lees de handleiding *Vorbereiding en veiligheid van de locatie Handleiding* voordat u het systeem installeert of gebruikt of voordat u onderhoud aan het systeem uitvoert. Deze handleiding bevat belangrijke beveiligingsvoorschriften waarvan u op de hoogte moet zijn voordat u met het systeem gaat werken.

Varoitus

Ennen kuin asennat järjestelmän tai käytät tai huollat sitä, lue *Asennuspaikan valmistelu-jaturvaopas* -opasta. Tässä oppaassa on tärkeitä turvallisuustietoja, jotka tulisi tietää ennen järjestelmän käyttämistä.

Attention

Avant d'installer le système, de l'utiliser ou d'assurer son entretien, veuillez lire le *Guide de sécurité et de préparation du site*. Celui-ci présente des informations importantes relatives à la sécurité, dont vous devriez prendre connaissance.

Warnung

Warnhinweis Bevor Sie das System installieren, in Betrieb setzen oder warten, lesen Sie die *Anleitung zur Standortvorbereitung und Sicherheitshinweise*. Dieses Handbuch enthält wichtige Informationen zur Sicherheit, mit denen Sie sich vor dem Verwenden des Systems vertraut machen sollten.

Avvertenza

Prima di installare, mettere in funzione o effettuare interventi di manutenzione sul sistema, leggere le informazioni contenute nella documentazione sulla *Guida alla sicurezza*. Tale guida contiene importanti informazioni che è necessario acquisire prima di iniziare qualsiasi intervento sul sistema.

Advarsel

Før du installerer, tar i bruk eller utfører vedlikehold på systemet, må du lese *Veiledning for stedsklargjøring og sikkerhet*. Denne håndboken inneholder viktig informasjon om sikkerhet som du bør være kjent med før du begynner å arbeide med systemet.

Aviso

Antes de instalar, funcionar com, ou prestar assistência ao sistema, leia o *Guia de Preparação e Segurança do Local*. Este guia contém informações de segurança importantes que deve conhecer antes de trabalhar com o sistema.

¡Advertencia!

Antes de instalar, manejar o arreglar el sistema, le aconsejamos que consulte la *Guía de prevención y preparación de una instalación*. Esta guía contiene importante información para su seguridad que debe saber antes de comenzar a trabajar con el sistema.

Varning!

Innan du installerar, använder eller utför service på systemet ska du läsa *Förberedelser och säkerhet Handbok*. Denna handbok innehåller viktig säkerhetsinformation som du bör känna till innan du arbetar med systemet.

**Warning**

To avoid electric shock, do not connect safety extra-low voltage (SELV) circuits to telephone-network voltage (TNV) circuits. LAN ports contain SELV circuits, and WAN ports contain TNV circuits. Some LAN and WAN ports both use RJ-45 connectors. Use caution when connecting cables.

Waarschuwing

Om elektrische schokken te vermijden, mogen veiligheidscircuits met extra lage spanning (genaamd SELV = Safety Extra-Low Voltage) niet met telefoonnetwerkspanning (TNV) circuits verbonden worden. LAN (Lokaal netwerk) poorten bevatten SELV circuits en WAN (Regionaal netwerk) poorten bevatten TNV circuits. Sommige LAN en WAN poorten gebruiken allebei RJ-45 connectors. Ga voorzichtig te werk wanneer u kabels verbindt.

Varoitus

Jotta välttyt sähköiskulta, älä kytke pienjännitteisiä SELV-suojapiirejä puhelinverkkojännitettä (TNV) käyttöviin virtapiireihin. LAN-portit sisältävät SELV-piirejä ja WAN-portit puhelinverkkojännitettä käyttäviä piirejä. Osa sekä LAN-että WAN-porteista käyttää RJ-45-liittimiä. Ole varovainen kytkiessäsi kaapeleita.

Attention

Pour éviter une électrocution, ne raccordez pas les circuits de sécurité basse tension (Safety Extra-Low Voltage ou SELV) à des circuits de tension de réseau téléphonique (Telephone Network Voltage ou TNV). Les ports du réseau local (LAN) contiennent des circuits SELV et les ports du réseau longue distance (WAN) sont munis de circuits TNV. Certains ports LAN et WAN utilisent des connecteurs RJ-45. Raccordez les câbles en prenant toutes les précautions nécessaires.

Warnung

Zur Vermeidung von Elektroschock die Sicherheits-Kleinspannungs-Stromkreise (SELV-Kreise) nicht an Fernsprechnetzspannungs-Stromkreise (TNV-Kreise) anschließen. LAN-Ports enthalten SELV-Kreise, und WAN-Ports enthalten TNV-Kreise. Einige LAN- und WAN-Ports verwenden auch RJ-45-Steckverbinder. Vorsicht beim Anschließen von Kabeln.

Avvertenza

Per evitare scosse elettriche, non collegare circuiti di sicurezza a tensione molto bassa (SELV) ai circuiti a tensione di rete telefonica (TNV). Le porte LAN contengono circuiti SELV e le porte WAN contengono circuiti TNV. Alcune porte LAN e WAN fanno uso di connettori RJ-45. Fare attenzione quando si collegano cavi.

Advarsel

Unngå å koble lavspenningskretser (SELV) til kretser for telenettspenning (TNV), slik at du unngår elektrisk støt. LAN-utganger inneholder SELV-kretser og WAN-utganger inneholder TNV-kretser. Det finnes både LAN-utganger og WAN-utganger som bruker RJ-45-kontakter. Vær forsiktig når du kobler kabler.

Aviso

Para evitar choques eléctricos, não conecte os circuitos de segurança de baixa tensão (SELV) aos circuitos de tensão de rede telefónica (TNV). As portas LAN contêm circuitos SELV e as portas WAN contêm circuitos TNV. Algumas portas LAN e WAN usam conectores RJ-45. Tenha o devido cuidado ao conectar os cabos.

¡Advertencia! Para evitar la sacudida eléctrica, no conectar circuitos de seguridad de voltaje muy bajo (safety extra-low voltage = SELV) con circuitos de voltaje de red telefónica (telephone network voltage = TNV). Los puertos de redes de área local (local area network = LAN) contienen circuitos SELV, y los puertos de redes de área extendida (wide area network = WAN) contienen circuitos TNV. En algunos casos, tanto los puertos LAN como los WAN usan conectores RJ-45. Proceda con precaución al conectar los cables.

Varning! För att undvika elektriska stötar, koppla inte säkerhetskretsar med extra låg spänning (SELV-kretsar) till kretsar med telefonnätspänning (TNV-kretsar). LAN-portar innehåller SELV-kretsar och WAN-portar innehåller TNV-kretsar. Vissa LAN- och WAN-portar är försedda med RJ-45-kontakter. Iaktta försiktighet vid anslutning av kablar.

Related Documentation

For information on the switch hardware configuration and maintenance procedures, refer to the switch *Installation Guide* and the *Site Preparation and Safety Guide*.

For information on your switch features and command-line interface (CLI) commands, refer to the *Configuration Guide* and *Command Reference* for your switch.

Obtaining Documentation

World Wide Web

You can access **the most current** Cisco documentation on the World Wide Web at <http://www.cisco.com>, <http://www-china.cisco.com>, or <http://www-europe.cisco.com>.

Documentation CD-ROM

Cisco documentation and additional literature are available in a CD-ROM package, which ships with your product. The Documentation CD-ROM is updated monthly. Therefore, it is **probably more current** than printed documentation. The CD-ROM package is available as a single unit or as an annual subscription.

Ordering Documentation

Registered CCO users can order the Documentation CD-ROM and other Cisco Product documentation through our online Subscription Services at <http://www.cisco.com/cgi-bin/subcat/kaojump.cgi>.

Nonregistered CCO users can order documentation through a local account representative by calling Cisco's corporate headquarters (California, USA) at 408 526-4000 or, in North America, call 800 553-NETS (6387).

Obtaining Technical Assistance

Cisco provides Cisco Connection Online (CCO) as a starting point for all technical assistance. Warranty or maintenance contract customers can use the Technical Assistance Center. All customers can submit technical feedback on Cisco documentation using the web, e-mail, a self-addressed stamped response card included in many printed docs, or by sending mail to Cisco.

Cisco Connection Online

Cisco continues to revolutionize how business is done on the Internet. Cisco Connection Online is the foundation of a suite of interactive, networked services that provides immediate, open access to Cisco information and resources at anytime, from anywhere in the world. This highly integrated Internet application is a powerful, easy-to-use tool for doing business with Cisco.

CCO's broad range of features and services helps customers and partners to streamline business processes and improve productivity. Through CCO, you will find information about Cisco and our networking solutions, services, and programs. In addition, you can resolve technical issues with online support services, download and test software packages, and order Cisco learning materials and merchandise. Valuable online skill assessment, training, and certification programs are also available.

Customers and partners can self-register on CCO to obtain additional personalized information and services. Registered users may order products, check on the status of an order and view benefits specific to their relationships with Cisco.

You can access CCO in the following ways:

- WWW: www.cisco.com
- Telnet: cco.cisco.com
- Modem **using standard connection rates** and the following terminal settings: VT100 emulation; 8 data bits; no parity; and 1 stop bit.
 - From North America, call 408 526-8070
 - From Europe, call 33 1 64 46 40 82

You can e-mail questions about using CCO to cco-team@cisco.com.

Technical Assistance Center

The Cisco Technical Assistance Center (TAC) is available to warranty or maintenance contract customers who need technical assistance with a Cisco product that is under warranty or covered by a maintenance contract.

To display the TAC web site that includes links to technical support information and software upgrades and for requesting TAC support, use www.cisco.com/techsupport.

To contact by e-mail, use one of the following:

Language	E-mail Address
English	tac@cisco.com
Hanzi (Chinese)	chinese-tac@cisco.com
Kanji (Japanese)	japan-tac@cisco.com

Language	E-mail Address
Hangul (Korean)	korea-tac@cisco.com
Spanish	tac@cisco.com
Thai	thai-tac@cisco.com

In North America, TAC can be reached at 800 553-2447 or 408 526-7209. For other telephone numbers and TAC e-mail addresses worldwide, consult the following web site:
<http://www.cisco.com/warp/public/687/Directory/DirTAC.shtml>.

Documentation Feedback

If you are reading Cisco product documentation on the World Wide Web, you can submit technical comments electronically. Click **Feedback** in the toolbar and select **Documentation**. After you complete the form, click **Submit** to send it to Cisco.

You can e-mail your comments to bug-doc@cisco.com.

To submit your comments by mail, for your convenience many documents contain a response card behind the front cover. Otherwise, you can mail your comments to the following address:

Cisco Systems, Inc.
 Document Resource Connection
 170 West Tasman Drive
 San Jose, CA 95134-9883

We appreciate and value your comments.

This document is to be used in conjunction with the documents listed in the “Related Documentation” section.

Access Registrar, AccessPath, Any to Any, AtmDirector, Browse with Me, CCDA, CCDE, CDDP, CCIE, CCNA, CCNP, CCSI, CD-PAC, the Cisco logo, Cisco Certified Internetwork Expert logo, CiscoLink, the Cisco Management Connection logo, the Cisco NetWorks logo, the Cisco Powered Network logo, Cisco Systems Capital, the Cisco Systems Capital logo, Cisco Systems Networking Academy, the Cisco Systems Networking Academy logo, the Cisco Technologies logo, ConnectWay, Fast Step, FireRunner, Follow Me Browsing, FormShare, GigaStack, IGX, Intelligence in the Optical Core, Internet Quotient, IP/VC, Kernel Proxy, MGX, Natural Network Viewer, NetSonar, Network Registrar, the Networkers logo, Packet, PIX, Point and Click Internetworking, Policy Builder, Precept, RateMUX, ScriptShare, Secure Script, ServiceWay, Shop with Me, SlideCast, SMARTnet, SVX, The Cell, TrafficDirector, TransPath, ViewRunner, Virtual Loop Carrier System, Virtual Voice Line, VlanDirector, Voice LAN, Wavelength Router, Workgroup Director, and Workgroup Stack are trademarks; Changing the Way We Work, Live, Play, and Learn, Empowering the Internet Generation, The Internet Economy, and The New Internet Economy are service marks; and Aironet, ASIST, BPX, Catalyst, Cisco, Cisco IOS, the Cisco IOS logo, Cisco Systems, the Cisco Systems logo, the Cisco Systems Cisco Press logo, Enterprise/Solver, EtherChannel, EtherSwitch, FastHub, FastLink, FastPAD, FastSwitch, GeoTel, IOS, IP/TV, IPX, LightStream, LightSwitch, MICA, NetRanger, Post-Routing, Pre-Routing, Registrar, StrataView Plus, Stratm, TeleRouter, and VCO are registered trademarks of Cisco Systems, Inc. or its affiliates in the U.S. and certain other countries. All other trademarks mentioned in this document are the property of their respective owners. The use of the word partner does not imply a partnership relationship between Cisco and any of its resellers. (0004R)

Copyright © 2000, Cisco Systems, Inc.
 All rights reserved. Printed in USA.