



CHAPTER 32

Configuring UDLD

This chapter describes how to configure the UniDirectional Link Detection (UDLD) protocol on the Catalyst 6500 series switches.



Note

For complete syntax and usage information for the commands that are used in this chapter, refer to the *Catalyst 6500 Series Switch Command Reference* publication.

This chapter consists of these sections:

- [Understanding How UDLD Works, page 32-1](#)
- [Default UDLD Configuration, page 32-2](#)
- [Configuring UDLD on the Switch, page 32-3](#)

Understanding How UDLD Works

The UDLD protocol allows devices that are connected through the fiber-optic or copper (for example, Category 5 cabling) Ethernet cables to monitor the physical configuration of the cables and detect when a unidirectional link exists. When a unidirectional link is detected, UDLD shuts down the affected port and alerts the user. The unidirectional links can cause a variety of problems, including spanning-tree topology loops.

UDLD is a Layer 2 protocol that works with the Layer 1 mechanisms to determine the physical status of a link. At Layer 1, autonegotiation takes care of physical signaling and fault detection. UDLD performs the tasks that autonegotiation cannot perform such as detecting the identities of neighbors and shutting down the misconnected ports. When you enable both autonegotiation and UDLD, the Layer 1 and Layer 2 detections work together to prevent the physical and logical unidirectional connections and the malfunctioning of other protocols.

A unidirectional link occurs whenever the traffic that is transmitted by the local device over a link is received by the neighbor but the traffic that is transmitted from the neighbor is not received by the local device. If one of the fiber strands in a pair is disconnected, as long as autonegotiation is active, the link does not stay up. In this case, the logical link is undetermined, and UDLD does not take any action. If both fibers are working normally from a Layer 1 perspective, then UDLD at Layer 2 determines whether those fibers are connected correctly and whether the traffic is flowing bidirectionally between the right neighbors. This check cannot be performed by autonegotiation, because autonegotiation is a Layer 1 mechanism.

The switch periodically transmits the UDLD messages (packets) to the neighbor devices on the ports that have UDLD enabled. If the messages are echoed back to the sender within a specific time frame and they are lacking a specific acknowledgment (echo), the link is flagged as unidirectional and the port is shut down. The devices on both ends of the link must support UDLD in order for the protocol to successfully identify and disable the unidirectional links.



Note

With supervisor engine software release 5.4(3) and later releases, you can specify the message interval between UDLD messages. Previously, the message interval was fixed at 60 seconds. With a configurable message interval, UDLD reacts much faster to link failures.



Note

By default, UDLD is locally disabled on the copper ports to avoid sending unnecessary control traffic on this type of media since it is often used for the access ports.

Figure 32-1 shows an example of a unidirectional link condition. Each switch can send packets to a neighbor switch but is not able to receive packets from the same switch that it is sending packets to. UDLD detects and disables these one-way connections.

Figure 32-1 Unidirectional Link

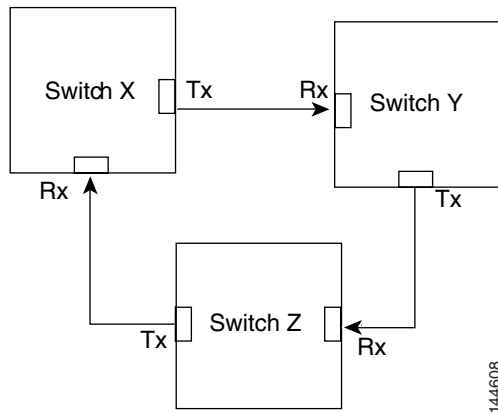

144608

Default UDLD Configuration

Table 32-1 shows the default UDLD configuration.

Table 32-1 UDLD Default Configuration

Feature	Default Value
UDLD global enable state	Globally disabled
UDLD per-port enable state for fiber-optic media	Enabled on all Ethernet fiber-optic ports
UDLD per-port enable state for twisted-pair (copper) media	Disabled on all Ethernet 10/100 and 1000BASE-TX ports
UDLD message interval	15 seconds
UDLD aggressive mode	Disabled

Configuring UDLD on the Switch

These sections describe how to configure UDLD:

- [Enabling UDLD Globally, page 32-3](#)
- [Enabling UDLD on Individual Ports, page 32-3](#)
- [Disabling UDLD on Individual Ports, page 32-4](#)
- [Disabling UDLD Globally, page 32-4](#)
- [Specifying the UDLD Message Interval, page 32-4](#)
- [Enabling UDLD Aggressive Mode, page 32-5](#)
- [Displaying the UDLD Configuration, page 32-5](#)

Enabling UDLD Globally

To enable UDLD globally on the switch, perform this task in privileged mode:

	Task	Command
Step 1	Enable UDLD globally on the switch.	set udld enable
Step 2	Verify the configuration.	show udld

This example shows how to enable UDLD globally and verify the configuration:

```

Console> (enable) set udld enable
UDLD enabled globally
Console> (enable) show udld
UDLD      : enabled
Console> (enable)

```

Enabling UDLD on Individual Ports

To enable UDLD on the individual ports, perform this task in privileged mode:

	Task	Command
Step 1	Enable UDLD on a specific port.	set udld enable <i>mod/port</i>
Step 2	Verify the configuration.	show udld port [<i>mod[/port]</i>]

This example shows how to enable UDLD on port 4/1 and verify the configuration:

```

Console> (enable) set udld enable 4/1
UDLD enabled on port 4/1
Console> (enable) show udld port 4/1
UDLD      : enabled
Message Interval: 15 seconds
Port      Admin Status  Aggressive Mode  Link State
-----
4/1      enabled           disabled         bidirectional
Console> (enable)

```

Disabling UDLD on Individual Ports

To disable UDLD on the individual ports, perform this task in privileged mode:

	Task	Command
Step 1	Disable UDLD on a specific port.	set udld disable <i>mod/port</i>
Step 2	Verify the configuration.	show udld port [<i>mod[/port]</i>]

This example shows how to disable UDLD on port 4/1:

```
Console> (enable) set udld disable 4/1
UDLD disabled on port 4/1.
Console> (enable)
```

Disabling UDLD Globally

To disable UDLD globally on the switch, perform this task in privileged mode:

	Task	Command
Step 1	Disable UDLD globally on the switch.	set udld disable
Step 2	Verify the configuration.	show udld

This example shows how to disable UDLD globally on the switch:

```
Console> (enable) set udld disable
UDLD disabled globally
Console> (enable)
```

Specifying the UDLD Message Interval

To specify the UDLD message interval, perform this task in privileged mode:

	Task	Command
Step 1	Specify the UDLD message interval.	set udld interval <i>interval</i>
Step 2	Verify the configuration.	show udld

This example shows how to specify the UDLD message interval on the switch:

```
Console> (enable) set udld interval 20
UDLD message interval set to 20 seconds
Console> (enable)
```

This example shows how to verify the message interval on the switch:

```
Console> (enable) show udld
UDLD : enabled
Message Interval : 20 seconds
Console> (enable)
```

Enabling UDLD Aggressive Mode

Software release 5.4(3) and later releases have UDLD aggressive mode. UDLD aggressive mode is disabled by default and its use is recommended only for point-to-point links between the Cisco switches running software release 5.4(3) or later releases. With UDLD aggressive mode enabled, when a port on a bidirectional link that has a UDLD neighbor relationship established stops receiving the UDLD packets, UDLD tries to reestablish the connection with the neighbor. After eight failed retries, the port is put into errdisable state.

To prevent the spanning-tree loops, normal UDLD with the default interval of 15 seconds is fast enough to shut down a unidirectional link before a blocking port transitions to the forwarding state (when the default spanning-tree parameters are used).

Enabling UDLD aggressive mode provides additional benefits in the following cases:

- One side of a link has a port stuck (both Tx and Rx)
- One side of a link remains up while the other side of the link has gone down

In these cases, UDLD aggressive mode errdisables one of the ports on the link and stops discarding the traffic. Even with aggressive mode disabled, there would be no risk for a broadcast storm due to a spanning-tree loop, because one port is unable to pass the traffic in both directions.

To enable UDLD aggressive mode, perform this task in privileged mode:

	Task	Command
Step 1	Enable UDLD aggressive mode.	set udld aggressive-mode enable <i>mod/port</i>
Step 2	Verify the configuration.	show udld

This example shows how to enable UDLD aggressive mode on the switch:

```
Console> (enable) set udld aggressive-mode enable 4/1
Aggressive UDLD enabled on port 4/1.
Console> (enable)
```

This example shows how to verify that UDLD aggressive mode is enabled on the switch:

```
Console> (enable) show udld port 4/1
UDLD      : enabled
Message Interval: 30 seconds
Port      Admin Status  Aggressive Mode  Link State
-----  -
4/1      enabled           Enabled          bidirectional
Console> (enable)
```

Displaying the UDLD Configuration

To display the UDLD enable state, perform this task in privileged mode:

Task	Command
Display the UDLD enable state.	show udld

This example shows how to display the UDLD enable state:

```
Console> (enable) show udld
UDLD                : enabled
Message Interval    : 15 seconds
Console> (enable)
```

To display UDLD configuration for a module or port, perform this task in privileged mode:

Task	Command
Display the UDLD configuration for a module or port.	show udld port [<i>mod</i>] [<i>mod/port</i>]

This example shows how to display the UDLD configuration for ports on module 4:

```
Console> (enable) show udld port 4
UDLD                : enabled
Message Interval: 15 seconds
Port      Admin Status  Aggressive Mode  Link State
-----  -
4/1      enabled         disabled         bidirectional
4/2      enabled         disabled         bidirectional
4/3      enabled         disabled         undetermined
4/4      enabled         disabled         bidirectional
.
.
```

Console> (enable)

Table 32-2 describes the fields in the **show udld** command output.

Table 32-2 *show udld Command Output Fields*

Field	Description
UDLD	Status of whether UDLD is enabled or disabled.
Message Interval	Message interval in seconds.
Port	Module and port number(s).
Admin Status	Status of whether administration status is enabled or disabled.
Aggressive Mode	Status of whether aggressive mode is enabled or disabled.
Link State	Status of the link: undetermined (detection in progress or UDLD on the neighbors has been disabled), not applicable (UDLD and/or the local port has been manually disabled), shutdown (unidirectional link has been detected and the port errdisabled), or bidirectional (a bidirectional link has been detected since the port is functioning properly in both directions).