



Configuring ASLB

This chapter describes how to configure accelerated server load balancing (ASLB) on the Catalyst 6500 series switches.



Note

For complete syntax and usage information for the commands used in this chapter, refer to the *Catalyst 6500 Series Switch Command Reference* publication.



Note

The information and procedures in this chapter apply only to the Supervisor Engine 1 with Layer 3 switching engine (Policy Feature Card or PFC). ASLB is not supported on Supervisor Engine 2 with Layer 3 Switching Engine II (PFC2).

This chapter consists of these sections:

- [Hardware and Software Requirements, page 45-1](#)
- [Understanding How ASLB Works, page 45-2](#)
- [Cabling Guidelines, page 45-7](#)
- [Configuring ASLB on the Switch, page 45-7](#)
- [ASLB Configuration Example, page 45-19](#)
- [ASLB Redundant Configuration Example, page 45-21](#)
- [Troubleshooting the ASLB Configuration, page 45-25](#)

Hardware and Software Requirements

The hardware and software requirements for your ASLB configuration are as follows:

- The LocalDirector requirements are as follows:
 - Hardware platforms—LocalDirector models 410, 415, 416, 420, or 430
 - Interface Modules—ASLB configuration requires two 10/100BASE-X Ethernet interfaces or two 1000BASE-X Gigabit Ethernet interfaces



Note 1000BASE-X interfaces are supported only on the LocalDirector 420 and 430. They are not supported on the LocalDirector 410, 415, or 416.

- Software—Cisco configuration version 3.2.x
- The Catalyst 6500 series switch requirements are as follows:
 - Supervisor engine with the Policy Feature Card (PFC)
 - Supervisor engine software release 5.3(1)CSX or later releases
- The participating routers are as follows:
 - Multilayer Switch Feature Card (MSFC)—With supervisor engine software release 5.4(1)CSX or later releases, an MSFC in the Catalyst 6500 series switch can be used as a participating router for ASLB. With earlier supervisor engine software releases, an internal MSFC *cannot* be a participating router.
 - External MSFC—An MSFC in an externally attached Catalyst 6500 series switch can be used as a participating router.
 - Multilayer Switch Module (MSM)—If the Catalyst 6500 series switch that you are using for ASLB has an MSM, it can be used as a participating router for ASLB. The MSM in an externally attached Catalyst 6500 series switch can also be used as a participating router.
 - Other Cisco routers can also be used as participating routers for ASLB.

Understanding How ASLB Works



Note Refer to the *Cisco LocalDirector Installation and Configuration Guide*, Version 3.2, for an overview on load balancing TCP/IP traffic.

These sections describe ASLB:

- [Layer 3 Operations for ASLB, page 45-3](#)
- [Layer 2 Operations for ASLB, page 45-3](#)
- [Client-to-Server Data Forwarding, page 45-4](#)
- [Server-to-Client Data Forwarding, page 45-6](#)

The LocalDirector is a secure, real-time, embedded operating system that intelligently load balances TCP/IP traffic across multiple servers. ASLB enables Catalyst 6500 series switches to cache Cisco LocalDirector load-balancing flows, which accelerates the performance of the LocalDirector.



Note The accelerated performance of the LocalDirector is achieved through the Catalyst 6500 series Layer 3 switching technology.

[Figure 45-1](#) shows a network that uses the ASLB feature. You must connect the LocalDirector to the switch with two links; one link connects to the same VLAN that the router is on and the other link connects to the VLAN that the servers are on. In [Figure 45-1](#), one LocalDirector link is connected to VLAN 10, the router VLAN; the other link is connected to VLAN 20, the server VLAN.

The LocalDirector supports directed mode and dispatched mode. Only the dispatched mode can be supported for ASLB feature implementation on Catalyst 6500 series switches.

Figure 45-1 ASLB Functional Description

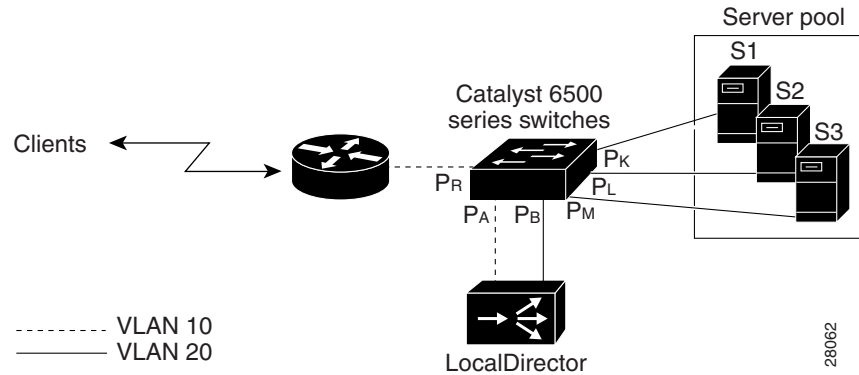

Layer 3 Operations for ASLB

You can specify up to 1024 server virtual-IP addresses and TCP port pairs for acceleration by the switch. All traffic for the virtual-IP/port pairs specified is accelerated except for the SYN, FIN, RST, and fragment packets with a nonzero offset. These packets are redirected to both the active and standby LocalDirectors (if a backup LocalDirector is configured).

Layer 2 Operations for ASLB

The Catalyst 6500 series switch content-addressable memory (CAM) table contains entries for the router VLAN and the server VLAN. In the CAM table, the router VLAN has an entry for the MAC address of the LocalDirector that is associated with a port index, and the server VLAN has entries for the router MAC addresses that are associated with port indexes. In these port indexes, the ports appear as 0/0. Display system CAM entries by entering the **show cam system** command.

Table 45-1 shows the entries in the CAM table (the ASLB configuration is shown in Figure 45-1). The first entry identifies the MAC address of the LocalDirector on VLAN 10. The CAM table shows that the MAC address has an Xtag value of 14. This value indicates that the MAC address requires a Layer 3 lookup. The second entry identifies the MAC address of the router and also requires a Layer 3 lookup.

Table 45-1 Layer 2 Table Entries

VLAN	MAC Address	Index	Xtag ¹
10	LocalDirector MAC	0/0	14
20	Router MAC ²	0/0	14

1. Xtag = The identifier field in the Layer 2 table that identifies the router to which the MAC address belongs.
2. Note that the router MAC address is added on the server VLAN (VLAN 20), not on the router VLAN (VLAN 10).

Client-to-Server Data Forwarding

Figure 45-2 shows how data is forwarded from the router to the servers. Table 45-2 lists the sequence of events, and Table 45-3 lists the Layer 3 table entries.

These sections describe the client-to-server data-forwarding paths:

- Path 1, page 45-4
- Path 2, page 45-4
- Path 3—N, page 45-4
- Path N + 1, N + 2..., page 45-4

Path 1

The first packet from the router has a destination MAC address of the LocalDirector and is on VLAN 10. The MAC address has an Xtag value of 14 in the Layer 2 table. This value indicates that it requires a Layer 3 lookup, and the SYN flag is set so the frame goes to port P_A.

In addition to forwarding the frame to port P_A, the switch hardware creates a “candidate” entry in the Layer 3 forwarding table. This entry is updated later by an “enabler” frame to become a full ASLB Multilayer Switching (MLS) entry.

Path 2

After receiving the frame from port P_A, the LocalDirector makes its standard load-balancing decision and forwards the frame to port P_B. The LocalDirector changes the destination MAC address to that of the appropriate server. When this frame enters the switch, it is considered an “enabler” frame. The switch hardware does a lookup in the Layer 3 table and searches for the entry created by the previous candidate packet (the packet forwarded through the LocalDirector). If the search was successful, a “hit” occurs in the Layer 3 table.

Path 3—N

The ASLB MLS entry has been created and the next and subsequent frames from the router with a destination MAC address of the LocalDirector MAC will be Layer 3 switched unless the packet has SYN, FIN, or RST flags set or the packet is fragmented.

Path N + 1, N + 2...

On the last frame of a connection, either the FIN or RST flags will be set in the TCP header causing the packet to go to the LocalDirector. The LocalDirector must then forward the frame back to the switch after modifying the destination MAC address to be that of the appropriate server. This redirected frame takes the same path as the first frame of the flow. The FIN packet is used by the LocalDirector as an indication that the connection with the server has been terminated, and by the ASLB to purge the affected ASLB MLS entry.

Figure 45-2 Client-to-Server ASLB Packet Flow

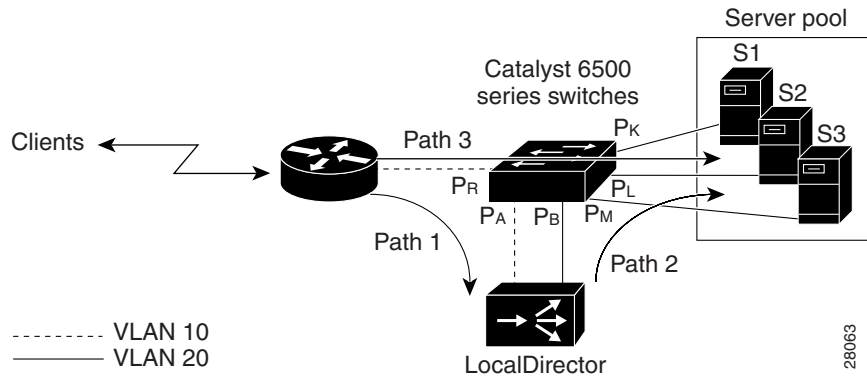

Table 45-2 Client-to-Server ASLB Packet Flow

Path Number	VLAN	MAC Destination Address	MAC Source Address	IP Destination Address	IP Source Address	Flags	Action
1	10	LocalDirector MAC ¹	Router MAC	VIP ²	CIP ³	SYN	Candidate entry in Layer 3 table
2	20	Server MAC ⁴	Router MAC ¹	VIP	CIP	-	Enabler frame
3—N	10	LocalDirector MAC ¹	Router MAC	VIP	CIP	-	Full ASLB MLS entry created
N + 1	10	LocalDirector MAC ¹	Router MAC	VIP	CIP	FIN/RST	Path 1 redirect
N + 2...	20	Server MAC	Router MAC ¹	VIP	CIP	FIN/RST	Path 2

1. This MAC address has an Xtag value of 14 in the Layer 2 table for this packet’s VLAN.
2. VIP = virtual-IP address.
3. CIP = client’s IP address.
4. MAC address of the server that the LocalDirector selected.

Table 45-3 Client-to-Server ASLB Layer 3 Table Entries

IP Destination Address	IP Source Address	Protocol	Ports	VLAN	MAC Destination Address	MAC Source Address
VIP ¹	CIP ²	TCP	80/YZ	20	Server MAC ³	Router MAC

1. VIP = virtual-IP address.
2. CIP = client’s IP address.
3. MAC address of the server that the LocalDirector selected.

Server-to-Client Data Forwarding

Figure 45-3 shows how data is forwarded from the servers to the clients. Table 45-4 lists the sequence of events, and Table 45-5 lists the Layer 3 table entries.

The traffic from the servers to the router or client devices works in the same manner, but in the reverse direction, as described in the “Client-to-Server Data Forwarding” section on page 45-4. The exception is that the LocalDirector put its own MAC address as the source of the packet for all packets that are going to the router. For the traffic in the client-to-server direction, the source MAC address of the packet was unmodified.

Figure 45-3 Server-to-Client ASLB Packet Flow

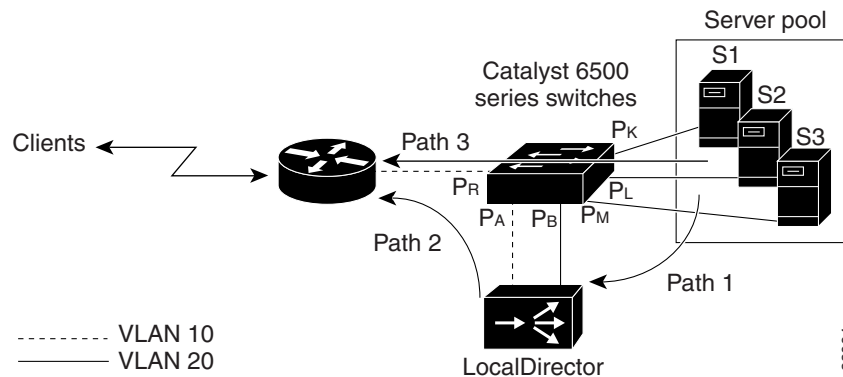

Table 45-4 Server-to-Client ASLB Packet Flow

Path Number	VLAN	MAC Destination Address	MAC Source Address	IP Destination Address	IP Source Address	Flags	Action
1	20	Router MAC ¹	Server MAC ²	CIP ³	VIP ⁴	SYN	Candidate entry in Layer 3 table
2	10	Router MAC	LocalDirector MAC ¹	CIP	VIP	-	Enabler packet
3—N	20	Router MAC ¹	Server MAC	CIP	VIP	-	Full ASLB MLS entry created
N + 1	20	Router MAC ¹	Server MAC	CIP	VIP	FIN/RST	Path 1 redirect
N + 2...	10	Router MAC	LocalDirector MAC ¹	CIP	VIP	FIN/RST	Path 2

1. This MAC address has an Xtag value of 14 in the Layer 2 table for this packet's VLAN.
2. MAC address of the server that the LocalDirector selected.
3. CIP = client's IP address.
4. VIP = virtual-IP address.

Table 45-5 Server-to-Client ASLB Layer 3 Table Entries

IP Destination Address	IP Source Address	Protocol	Ports	VLAN	MAC Destination Address	MAC Source Address
VIP ¹	CIP ²	TCP	80/YZ	20	Server MAC ³	Router MAC
CIP	VIP	TCP	YZ/80	10	Router MAC	LocalDirector MAC

1. VIP = virtual-IP address.
2. CIP = client's IP address.
3. MAC address of the server that the LocalDirector selected.

Cabling Guidelines

This section describes the cabling guidelines for your ASLB configuration:

- Check your connections to the servers that are attached to the switch. The servers must be either directly attached to the switch or within the same bridging domain as the LocalDirector port in the server VLAN.
- Use two Category 5 unshielded twisted-pair cables to connect two 10/100 or two 1000BASE-X switch ports to two comparable LocalDirector interfaces.



Caution

Connect the LocalDirector directly to the Catalyst 6500 series switch.

See the “[Configuring the LocalDirector Interfaces](#)” section on page 45-7 to configure the LocalDirector interfaces. See the “[Configuring ASLB from the CLI](#)” section on page 45-11 to configure the switch.

Configuring ASLB on the Switch

This section lists the tasks to configure ASLB:

- [Configuring the LocalDirector Interfaces, page 45-7](#)
- [ASLB Configuration Guidelines, page 45-8](#)
- [Configuring ASLB from the CLI, page 45-11](#)

Configuring the LocalDirector Interfaces

Refer to the *Cisco LocalDirector Installation and Configuration Guide*, Version 3.2, for detailed information on configuring the LocalDirector interfaces for ASLB.

ASLB Configuration Guidelines

This section lists the usage guidelines and restrictions for configuring ASLB:

- [Routers, page 45-8](#)
- [Servers, page 45-8](#)
- [IP Addresses, page 45-9](#)
- [Supervisor Engine, page 45-9](#)
- [Backup LocalDirector Configuration \(Optional\), page 45-9](#)
- [MSFC and Multilayer Switching, page 45-10](#)
- [NetFlow Data Export, page 45-10](#)
- [VLANs, page 45-10](#)
- [Switch Port Configuration, page 45-10](#)

For configuration examples, see the “[ASLB Configuration Example](#)” section on [page 45-19](#). If you run into problems during your configuration, see the “[Troubleshooting the ASLB Configuration](#)” section on [page 45-25](#).

Routers

The router configuration guidelines are as follows:

- The router must be the default gateway for the servers that are being load balanced, and its MAC address must be known.
- Multiple routers must be on the same router VLAN. Specify all the participating router MAC addresses using the **set lda mac router** command.
- When ASLB is configured, a VLAN access control list (VACL) is created to redirect TCP traffic on the two VLANs to which the LocalDirector is connected; no security Cisco IOS access control lists (ACLs) or VACLs can be configured on these VLANs.

Servers

The server configuration guidelines are as follows:

- The servers must be either directly attached to the switch or within the same bridging domain as the LocalDirector port in the server VLAN.
- Configure the server default route as the aliased address of the router that is on the same subnet as the real IP address of the server.
- Configure the servers to ignore the ARP requests for the virtual-IP address. On some server operating systems, you cannot disable the responses to the ARP requests on the alias (secondary) IP addresses. Use the static ARP entries at the routers as a workaround for the servers that respond to the ARP requests for the virtual-IP address.



Caution

To accelerate the client-to-server traffic, you must configure the servers to ignore the ARP requests for the virtual-IP address. If you fail to do this step, traffic acceleration will not start, and fully redundant topologies in your network will take a long time to recover from a LocalDirector failure.

IP Addresses

The IP address configuration guidelines are as follows:



Note

You can specify an IP address for the virtual-IP address other than server IP network addresses.

- Ensure that the LocalDirectors and servers are on the same subnet to allow the LocalDirector to ARP the real IP address of each server.
- Ensure that the routers are on the same subnet as the virtual-IP address to allow the router to ARP the virtual-IP address.

Configure the network for ASLB as follows (the virtual-IP address in this example is 171.1.1.200):

Router	LocalDirector	Servers ¹
171.1.1.1	171.1.1.2	171.1.1.x

1. The default router on each server is 171.1.1.1.

If the servers in your ASLB configuration need to follow RFC 1918 for privacy, use the following as a guideline (the virtual-IP address in this example is 171.1.1.200):

Routers	LocalDirector	Servers ¹
171.1.1.1	171.1.1.2	10.1.1.x (real IP address)
Alias 10.1.1.1	Alias 10.1.1.2	Loopback alias to 171.1.1.200

1. The default router on each server is 10.1.1.1.

Supervisor Engine

The supervisor engine configuration guidelines are as follows:

- Up to 32 router MAC addresses are supported.
- Up to 1024 virtual-IP/TCP port pairs are supported.

Backup LocalDirector Configuration (Optional)

Connect the ports on the backup LocalDirector to the switch and specify the server and router configuration using the **set lda server** and **set lda router** commands. Connect the active and backup LocalDirectors to their specified ports or the ASLB feature will not work.

MSFC and Multilayer Switching

The MSFC and Multilayer Switching (MLS) configuration guidelines are as follows:

- With supervisor engine software release 5.4(1)CSX or later releases, an MSFC can be the participating router for ASLB.



Note Traffic is Layer 3 switched when an MSFC routes traffic from clients. This process creates MLS entries that exist separately from the ASLB MLS entries for the same traffic.

- The aging task that removes terminated ASLB flows also purges MLS terminated flows. ASLB MLS entries share the Layer 3 MLS cache with the MLS shortcut entries.

The MLS commands (**set mls**, **clear mls**, and **show mls**) do not interoperate with ASLB (**set lda**, **clear lda**, **show lda**, and **commit lda**) commands. ASLB uses separate commands to view the LocalDirector MLS entries.

- When you enable ASLB, ASLB MLS entries are established using one flow mask, full-flow mode (ip-flow).

NetFlow Data Export

You cannot use NetFlow Data Export (NDE) if you enable ASLB, and you cannot use ASLB if you enable NDE.

VLANs

The VLAN configuration guidelines are as follows:

- When you configure ASLB, a VACL is created to redirect TCP traffic on the two VLANs to which the LocalDirector is connected (router VLAN and server VLAN). You cannot configure any security Cisco IOS ACLs or VACLs on these VLANs.
- Dedicate the router VLAN and server VLAN for ASLB use only. Do not connect other network devices (such as end stations and clients) to these two VLANs.
- The VLANs that are created for ASLB propagate to other switches through VLAN Trunking Protocol (VTP) when VTP is in the server mode. Spanning Tree Protocol runs over these ASLB VLANs on all VTP switches in the network, introducing additional overhead over the entire network. To avoid spanning tree propagation delays, do the following:
 - Configure the switch as VTP transparent so it does not populate the VLANs.
 - Remove the ASLB VLANs from all trunks on all switches (enter the **clear trunk** command).

Switch Port Configuration

The switch port configuration guidelines are as follows:

- Disable CDP on ports that are connected to the LocalDirectors (both active and standby LocalDirectors if a backup is configured).
- If you specify a port that is part of an EtherChannel, traffic is automatically redirected among all ports in the EtherChannel.

Configuring ASLB from the CLI

This section describes how to configure ASLB using the Catalyst 6500 series switch **lda** command set and includes the following descriptions:

- [Configuring the Switch Ports Connected to the LocalDirector, page 45-11](#)
- [Enabling and Disabling ASLB, page 45-11](#)
- [Specifying Server Virtual-IP Addresses and TCP Ports for Acceleration, page 45-12](#)
- [Specifying MAC Addresses for Participating Routers, page 45-12](#)
- [Specifying a MAC Address for the LocalDirector, page 45-13](#)
- [Specifying the Router VLAN and the LocalDirector Port on the VLAN, page 45-13](#)
- [Specifying the Server VLAN and the LocalDirector Port on the VLAN, page 45-14](#)
- [Configuring UDP Aging, page 45-14](#)
- [Committing the ASLB Configuration, page 45-14](#)
- [Displaying the ASLB Configuration, page 45-15](#)
- [Displaying the ASLB MLS Entries, page 45-16](#)
- [Displaying the ASLB MLS Statistics, page 45-17](#)
- [Clearing the ASLB Configuration, page 45-18](#)

Configuring the Switch Ports Connected to the LocalDirector

To configure the 10/100-Ethernet switch ports that are connected to the LocalDirector, perform these steps:

- Step 1** Enter the **set vlan *vlan_num mod_ports*** command to add the switch ports to the correct VLANs (router VLAN and server VLAN).
- Step 2** Note that the port speed and duplex type for the switch ports do not need to be set as all 10/100-switch ports are set to autonegotiate as the default. If you have a problem with autonegotiation, configure the port speed and duplex type as follows:
- Enter the **set port speed *mod/port* {10 | 100 | auto}** command to set the port speed.
- Enter the **set port duplex *mod/port* {full | half | auto}** command to set the type of duplex.

Enabling and Disabling ASLB



Note

ASLB is disabled by default. When ASLB is disabled, you cannot enter the **set lda** commands to perform configuration tasks; to enter the **set lda** commands, you must enable ASLB.

To enable or disable ASLB, perform this task in privileged mode:

Task	Command
Enable or disable ASLB.	set lda enable disable

This example shows how to enable ASLB on the switch:

```
Console> (enable) set lda enable
Successfully enabled Local Director Accelerator.
Console> (enable)
```

This example shows how to disable ASLB on the switch:

```
Console> (enable) set lda disable
Successfully disabled Local Director Accelerator.
Console> (enable)
```

Specifying Server Virtual-IP Addresses and TCP Ports for Acceleration



Note

You can specify up to 1024 virtual-IP addresses and TCP port pairs for acceleration by the Catalyst 6500 series switch. Newly specified pairs do not replace previously specified pairs. To cancel a previously entered pair, enter the **clear lda vip** command.



Note

You can use a zero (0) as a wildcard (don't care) digit for the *destination_tcp_port*.

To specify server virtual-IP addresses and TCP ports for acceleration, perform this task in privileged mode:

Task	Command
Specify server virtual-IP addresses and TCP ports for acceleration.	set lda vip { <i>server_virtual_ip</i> } { <i>destination_tcp_port</i> } [{ <i>server_virtual_ip</i> } { <i>destination_tcp_port</i> }...]

This example shows how to specify a server virtual-IP address and TCP port for acceleration:

```
Console> (enable) set lda vip 10.0.0.8 8
Successfully set server virtual ip and port information.
Use commit lda command to save settings to hardware.
Console> (enable)
```

Specifying MAC Addresses for Participating Routers



Note

You can specify up to 32 router MAC addresses.

To specify MAC addresses for participating routers, perform this task in privileged mode:

Task	Command
Specify MAC addresses for participating routers.	set lda mac router { <i>mac-address</i> }...

This example shows how to specify MAC addresses for participating routers:

```
Console> (enable) set lda mac router 00-23-45-67-ee-7f
Successfully set mac address.
Use commit lda command to save settings to hardware.
Console> (enable)
```

Specifying a MAC Address for the LocalDirector

To specify a MAC address for the LocalDirector, perform this task in privileged mode:

Task	Command
Specify a MAC address for the LocalDirector.	set lda mac ld {ld_mac-address}

This example shows how to specify a MAC address for the LocalDirector:

```
Console> (enable) set lda mac ld 00-11-22-33-55-66
Successfully set mac address.
Use commit lda command to save settings to hardware.
Console> (enable)
```

Specifying the Router VLAN and the LocalDirector Port on the VLAN



Note

After entering the **set lda router** command, if you change the switch port(s) to which the LocalDirector is connected, you must enter the **set lda router** command again to specify the new configuration.



Note

Specifying a backup LocalDirector port is optional unless you are setting up a failover configuration of LocalDirectors. If you are setting up a failover configuration, you must specify the ports for the backup LocalDirector. If this is not done, failover will not work because the supervisor engine will not send any traffic to the intended backup LocalDirector.

To specify the router VLAN and the LocalDirector port on the VLAN, perform this task in privileged mode:

Task	Command
Specify the router VLAN and the LocalDirector port on the VLAN.	set lda router {router_vlan} {ld_mod/port} <i>[backup_ld_mod/port]</i>

This example shows how to specify the router VLAN and the LocalDirector port on the VLAN:

```
Console> (enable) set lda router 110 4/26
Successfully set router vlan and LD port.
Use commit lda command to save settings to hardware.
Console> (enable)
```

Specifying the Server VLAN and the LocalDirector Port on the VLAN



Note

After entering the **set lda server** command, if you change the switch port(s) to which the LocalDirector is connected, you must enter the **set lda server** command again to specify the new configuration.



Note

Specifying a backup LocalDirector port is optional unless you are setting up a failover configuration of LocalDirectors. If you are setting up a failover configuration, you must specify the ports for the backup LocalDirector. If this is not done, failover will not work because the supervisor engine will not send any traffic to the intended backup LocalDirector.

To specify the server VLAN and the LocalDirector port on the VLAN, perform this task in privileged mode:

Task	Command
Specify the server VLAN and the LocalDirector port on the VLAN.	set lda server {server_vlan} {ld_mod/port} [backup_ld_mod/port]

This example shows how to specify the server VLAN and the LocalDirector port on the VLAN:

```
Console> (enable) set lda server 105 4/40
Successfully set server vlan and LD port.
Use commit lda command to save settings to hardware.
Console> (enable)
```

Configuring UDP Aging

To configure User Datagram Protocol (UDP) aging, perform this task in privileged mode:

Task	Command
Configure UDP aging.	set lda udpage time_in_ms

You can set aging from 1–2024000 milliseconds (ms). Enter a value of zero to disable UDP aging.

This example shows how to configure UDP aging to 500 ms:

```
Console> (enable) set lda udpage 500
Successfully set LDA UDP aging time to 500ms.
Console> (enable)
```

Committing the ASLB Configuration



Note

ASLB configuration settings are temporarily stored in an edit buffer. The settings are saved in NVRAM, but for the settings to take effect, you must enter the **commit lda** command. This command verifies your configuration settings. If the information is entered correctly and passes a consistency check, the settings are programmed into hardware. Once the ASLB configuration is successfully committed, the mapping is saved in NVRAM and restored at system bootup.

To commit your ASLB configuration settings, perform this task in privileged mode:

Task	Command
Commit your ASLB configuration settings.	commit lda

This example shows how to commit the ASLB configuration settings:

```
Console> (enable) commit lda
Commit operation in progress...
Successfully committed Local Director Accelerator.
Console> (enable)
```

Displaying the ASLB Configuration



Note

Entering **show lda** without a keyword (**committed** | **uncommitted**) displays committed configuration settings.

To display committed or uncommitted ASLB configuration settings, perform this task in privileged mode:

Task	Command
Display committed or uncommitted ASLB configuration settings.	show lda [committed uncommitted]

This example shows how to display committed ASLB configuration settings:

```
Console> (enable) show lda committed
Status:Committed

Virtual IP addresses:
Local Director Flow:10.0.0.8/ (TCP port 8)

Router MAC:
00-23-45-67-ee-7f

LD MAC:00-11-22-33-55-66

LD Router Side:
-----
Router and LD are on VLAN 110
LD is connected to switch port 4/26 on VLAN 110

LD Server Side:
-----
Server(s) and LD are on VLAN 105
LD is connected to switch port 4/40 on VLAN 105
Console> (enable)
```

If the configuration is then modified and the changes are not committed, entering the **show lda** command again gives an indication that the configuration has been modified since the last commit but the new modifications are not shown, only the committed modifications are displayed. To view the new modifications, enter the **show lda uncommitted** command.

Displaying the ASLB MLS Entries



Note

The **short | long** options give the flexibility to display the output in regular (80 characters in width) or wide-screen format.

To display the ASLB MLS entries, perform this task in privileged mode:

Task	Command
Display the ASLB MLS entries.	<pre>show lda mls entry show lda mls entry [destination ip_addr_spec] [source ip_addr_spec] [protocol protocol] [src-port port] [dst-port port] [short long]</pre>

This example shows how to display all ASLB MLS entries in short format:

```
Console> (enable) show lda mls entry short
Destination-IP Source-IP Prot DstPrt SrcPrt Destination-Mac Vlan
-----
EDst ESrc DPort SPort Stat-Pkts Stat-Bytes Uptime Age
-----
10.0.0.8 172.20.20.10 TCP 8 64 00-33-66-99-22-44 105
ARPA ARPA - 4/25 0 0 00:00:02 00:00:05
10.0.0.8 172.20.20.11 TCP 8 64 00-33-66-99-22-44 105
ARPA ARPA - 4/25 0 0 00:00:05 00:00:08
Console> (enable)
```

This example shows how to display ASLB information for the source IP address in short format:

```
Console> (enable) show lda mls entry source 172.20.20.11 short
Destination-IP Source-IP Prot DstPrt SrcPrt Destination-Mac Vlan
-----
EDst ESrc DPort SPort Stat-Pkts Stat-Bytes Uptime Age
-----
10.0.0.8 172.20.20.11 TCP 8 64 00-33-66-99-22-44 105
ARPA ARPA - 4/25 0 0 00:00:05 00:00:08
Console> (enable)
```

Displaying the ASLB MLS Statistics

To display the ASLB MLS statistics, perform this task in privileged mode:

Task	Command
Display ASLB MLS entry statistics.	<pre>show lda mls statistics entry show lda mls statistics count show lda mls statistics entry [destination ip_addr_spec] [source ip_addr_spec] [protocol protocol] [src-port port] [dst-port port]</pre>

This example shows how to display all ASLB MLS entry statistics:

```
Console> (enable) show lda mls statistics entry
                               Last   Used
Destination IP  Source IP      Prot DstPrt SrcPrt Stat-Pkts Stat-Bytes
-----
10.0.0.8        172.20.20.10  TCP  WWW    64    636    29256
10.0.0.8        172.20.22.10  TCP  WWW    64     0      0
Console> (enable)
```

This example shows how to display the number of ASLB active MLS entries:

```
Console> (enable) show lda mls statistics count
LDA active shortcuts: 20
Console> (enable)
```

This example shows how to display the statistics for a specific destination IP address:

```
Console> (enable) show lda mls statistics entry destination 172.20.22.14
                               Last   Used
Destination IP  Source IP      Prot DstPrt SrcPrt Stat-Pkts Stat-Bytes
-----
172.20.22.14   172.20.25.10  6    50648  80    3152   347854
Console> (enable)
```

Clearing the ASLB Configuration



Caution

If you do not enter any keywords with the **clear lda** command, the *entire* ASLB configuration (including the MLS entries) is removed from the hardware and NVRAM. If you do not enter any keywords with the **clear lda mls** command, all MLS entries are cleared.

To clear ASLB entries or router MAC addresses, perform this task in privileged mode:

Task	Command
Clear ASLB configuration settings.	<pre>clear lda mls clear lda mls [destination <i>ip_addr_spec</i>] [source <i>ip_addr_spec</i>] [protocol <i>protocol</i> src-port <i>src_port</i> dst-port <i>dst_port</i>] clear lda vip {all <i>vip</i> <i>vip tcp_port</i>} clear lda mac {all <i>router_mac_address</i>}</pre>

This example shows how to clear the MLS entry at a specific destination address:

```
Console> (enable) clear lda mls destination 172.20.26.22
MLS IP entry cleared.
Console> (enable)
```

This example shows how to delete a virtual-IP address and port pair (10.0.0.8, port 8):

```
Console> (enable) clear lda vip 10.0.0.8 8
Successfully deleted vip/port pairs.
Console> (enable)
```

This example shows how to clear all ASLB router MAC addresses:

```
Console> (enable) clear lda mac all
Successfully cleared Router MAC address.
Console> (enable)
```

This example shows how to clear a specific ASLB router MAC address:

```
Console> (enable) clear lda mac 1-2-3-4-5-6
Successfully cleared Router MAC address.
Console> (enable)
```

ASLB Configuration Example

This section provides an example of a typical ASLB network configuration. [Figure 45-4](#) shows the example network. The configuration specifications are as follows:

- The virtual-IP address is 192.255.201.55.
- The router interface MAC address is 00-d0-bc-e9-fb-47 and its IP address is 192.255.201.1.
- The LocalDirector IP address is 192.255.201.2.
- The LocalDirector MAC address is 00-e0-b6-00-4b-04.
- The server farm IP addresses are 192.255.201.3 through 192.255.201.11.
- The servers have been configured to ignore ARP requests for the virtual-IP address 192.255.201.55.

The example in [Figure 45-4](#) shows how to do the following:

- Load balance HTTP connections in a round-robin sequence among servers 192.255.201.3 through 192.255.201.10.
- Forward connections to port 8001 to server 192.255.201.11.
- Load balance FTP connections to servers 192.255.201.3 through 192.255.201.8 in a “leastconns” sequence (which is the default for the LocalDirector).

Figure 45-4 ASLB Configuration Example

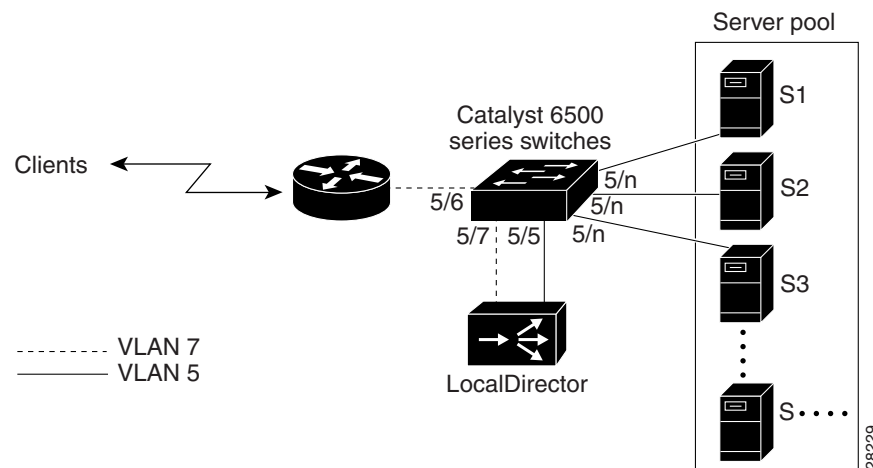

The router configuration is as follows (MSM is used in this example):

```
!
interface Port-channel1.7
encapsulation isl 7
ip address 192.255.201.1 255.255.255.0
no ip redirects
no ip directed-broadcast
!
```

The Catalyst 6500 series switch configuration is as follows:

```
Console (enable) show lda
Status:Committed

Virtual IP addresses:
Local Director Flow:192.255.201.55/www (TCP port 80)
Local Director Flow:192.255.201.55/ (TCP port 8001)
Local Director Flow:192.255.201.55/ftp (TCP port 21)

Router MAC:
00-d0-bc-e9-fb-47

LD MAC: 00-e0-b6-00-4b-04

LD Router Side:
-----
Router and LD are on VLAN 7
LD is connected to switch port 5/7 on VLAN 7

LD Server Side:
-----
Server(s) and LD are on VLAN 5
LD is connected to switch port 5/5 on VLAN 5
Console (enable)
```

The LocalDirector configuration is as follows:

```
LD430# show configuration
:Saved
:LocalDirector 430 Version 3.1.3.105
syslog output 20.3
no syslog console
hostname LD430
no shutdown ethernet 0
no shutdown ethernet 1
shutdown ethernet 2
shutdown ethernet 3
interface ethernet 0 100full
interface ethernet 1 100full
interface ethernet 2 auto
interface ethernet 3 auto
mtu 0 1500
mtu 1 1500
mtu 2 1500
mtu 3 1500
no multiring all
no secure 0
no secure 1
no secure 2
no secure 3
ping-allow 0
```

```

ping-allow 1
no ping-allow 2
no ping-allow 3

ip address 192.255.201.2 255.255.255.0
route 0.0.0.0 0.0.0.0 192.255.201.1 1
no rip passive
rip version 1
failover ip address 0.0.0.0
no failover
snmp-server enable traps
no snmp-server contact
no snmp-server location
virtual 192.255.201.55:80:0:tcp is
virtual 192.255.201.55:8001:0:tcp is
virtual 192.255.201.55:21:0:tcp is
predictor 192.255.201.55:80:0:tcp roundrobin
redirection 192.255.201.55:80:0:tcp dispatched assisted wildcard-ttl 60
fixed-ttl 60 igmp 224.0.1.2 port 1637
redirection 192.255.201.55:8001:0:tcp dispatched assisted wildcard-ttl 60
fixed-ttl 60 igmp 224.0.1.2 port 1637
redirection 192.255.201.55:21:0:tcp dispatched assisted wildcard-ttl 60
fixed-ttl 60 igmp 224.0.1.2 port 1637
real 192.255.201.5:80:0:tcp is
real 192.255.201.3:80:0:tcp is
real 192.255.201.4:80:0:tcp is
real 192.255.201.6:80:0:tcp is
real 192.255.201.7:80:0:tcp is
real 192.255.201.8:80:0:tcp is
real 192.255.201.9:80:0:tcp oos
real 192.255.201.10:80:0:tcp oos
real 192.255.201.11:8001:0:tcp oos
real 192.255.201.3:21:0:tcp is
real 192.255.201.4:21:0:tcp is
real 192.255.201.5:21:0:tcp is
real 192.255.201.6:21:0:tcp is
real 192.255.201.7:21:0:tcp is
real 192.255.201.8:21:0:tcp is
bind 192.255.201.55:80:0:tcp 192.255.201.3:80:0:tcp
bind 192.255.201.55:80:0:tcp 192.255.201.4:80:0:tcp
bind 192.255.201.55:80:0:tcp 192.255.201.5:80:0:tcp
bind 192.255.201.55:80:0:tcp 192.255.201.6:80:0:tcp
bind 192.255.201.55:80:0:tcp 192.255.201.7:80:0:tcp
bind 192.255.201.55:80:0:tcp 192.255.201.8:80:0:tcp
bind 192.255.201.55:80:0:tcp 192.255.201.9:80:0:tcp
bind 192.255.201.55:80:0:tcp 192.255.201.10:80:0:tcp
bind 192.255.201.55:8001:0:tcp 192.255.201.11:8001:0:tcp
bind 192.255.201.55:21:0:tcp 192.255.201.3:21:0:tcp
bind 192.255.201.55:21:0:tcp 192.255.201.4:21:0:tcp
bind 192.255.201.55:21:0:tcp 192.255.201.5:21:0:tcp
bind 192.255.201.55:21:0:tcp 192.255.201.6:21:0:tcp
bind 192.255.201.55:21:0:tcp 192.255.201.7:21:0:tcp
bind 192.255.201.55:21:0:tcp 192.255.201.8:21:0:tcp

```

ASLB Redundant Configuration Example

This section provides an example of a typical ASLB redundant network configuration. [Figure 45-5](#) shows the example redundant network. The LocalDirectors and Catalyst 6500 series switches are configured to accelerate HTTP and Telnet for server VIP address 13.13.13.13.

**Caution**

Router 1 and router 2 are running Hot Standby Router Protocol (HSRP) on both interfaces, f1 and f2 in Figure 45-5. Interface f1 must be active on the same router where f2 is active; otherwise, traffic will reach interface f1 on one router and will not be forwarded to interface f2 which is active on the other router. Use the HSRP **track** command to track the opposite side interface of each router.

Figure 45-5 ASLB Redundant Configuration Example

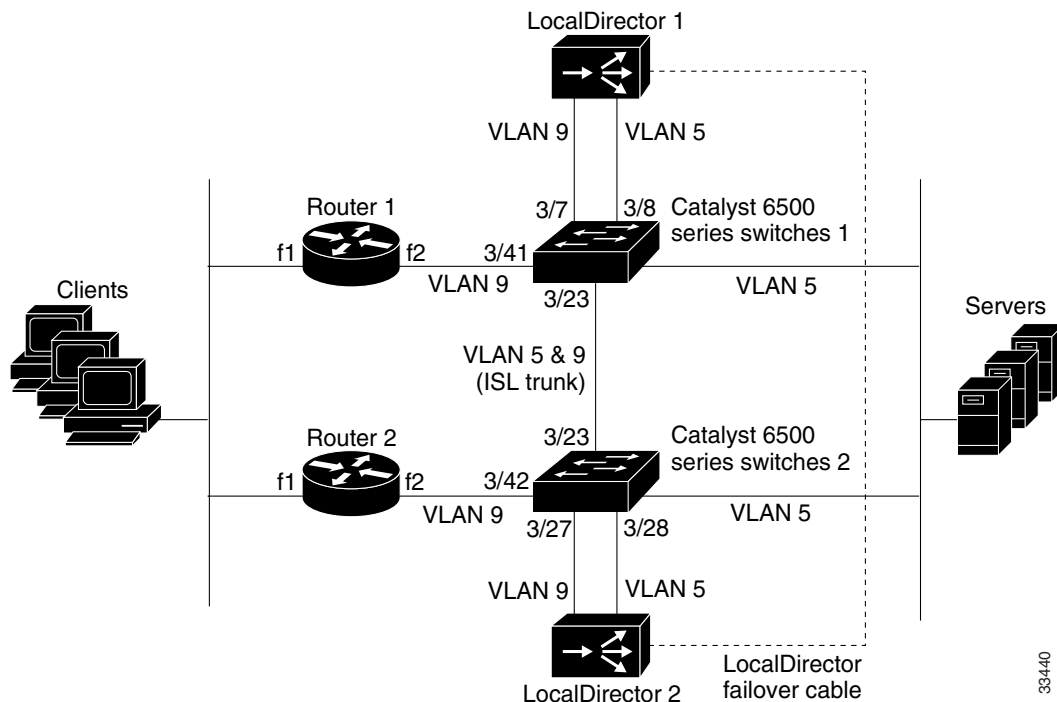

33440

IP Addresses

The IP addresses are as follows:

- Router 1, f1 IP address: 7.0.0.100 (network 7)
- Router 2, f1 IP address: 7.0.0.101 (network 7)
- HSRP IP address: 7.0.0.1 for network 7
- Router 1, f2 IP address: 5.0.0.100 (network 5)
- Router 2, f2 IP address: 5.0.0.101 (network 5)
- HSRP IP address: 5.0.0.2 for network 5
- LocalDirector IP address: 5.0.0.1
- Server IP address: 5.100.100.100
- VIP address for servers: 13.13.13.13

MAC Addresses

The MAC addresses are as follows:

- HSRP MAC address for network 7: 00-00-0c-07-ac-00
- HSRP MAC address for network 5: 00-00-0c-07-ac-01
- Router 1, f2 MAC address: 00-d0-79-7b-20-88
- Router 2, f2 MAC address: 00-d0-79-7b-18-88
- LocalDirector MAC address: 00-e0-b6-00-47-ec

Catalyst 6500 Series Switch 1 Configuration

The switch 1 configuration is as follows:

```
set trunk 3/23 on isl 1,5,9
set lda enable
clear lda vip all
set lda vip 13.13.13.13 80 13.13.13.13 23
clear lda mac all
set lda mac router 00-00-0c-07-ac-01
set lda mac router 00-d0-79-7b-20-88
set lda mac router 00-d0-79-7b-18-88
set lda mac ld 00-e0-b6-00-47-ec
set lda router 9 3/7 3/23
set lda server 5 3/8 3/23
commit lda
```

Catalyst 6500 Series Switch 2 Configuration

The switch 2 configuration is as follows:

```
set trunk 3/23 on isl 1,5,9
set lda enable
clear lda vip all
set lda vip 13.13.13.13 80 13.13.13.13 23
clear lda mac all
set lda mac router 00-00-0c-07-ac-01
set lda mac router 00-d0-79-7b-20-88
set lda mac router 00-d0-79-7b-18-88
set lda mac ld 00-e0-b6-00-47-ec
set lda router 9 3/27 3/23
set lda server 5 3/28 3/23
commit lda
```

Router 1 Configuration

The router 1 configuration is as follows:

```
interface FastEthernet1
 ip address 7.0.0.100 255.0.0.0
 no ip redirects
 no ip directed-broadcast
 no ip route-cache distributed
 load-interval 30
 no keepalive
```

```

full-duplex
standby 1 ip 7.0.0.1
standby 1 track FastEthernet2
!
interface FastEthernet2
ip address 5.0.0.100 255.0.0.0
no ip redirects
no ip directed-broadcast
no ip route-cache distributed
no keepalive
full-duplex
standby priority 250
standby 2 ip 5.0.0.2
standby 2 track FastEthernet1
!
ip route 13.13.13.13 255.255.255.255 5.0.0.1

```

Router 2 Configuration

The router 2 configuration is as follows:

```

interface FastEthernet1
ip address 7.0.0.101 255.0.0.0
no ip redirects
no ip directed-broadcast
no ip route-cache distributed
load-interval 30
no keepalive
full-duplex
standby 1 ip 7.0.0.1
standby 1 track FastEthernet2
!
interface FastEthernet2
ip address 5.0.0.101 255.0.0.0
no ip redirects
no ip directed-broadcast
no ip route-cache distributed
no keepalive
full-duplex
standby priority 250
standby 2 ip 5.0.0.2
standby 2 track FastEthernet1
!
ip route 13.13.13.13 255.255.255.255 5.0.0.1

```

LocalDirector Configuration

The LocalDirector 1 and LocalDirector 2 configuration is as follows (the configuration is the same for both LocalDirectors):

```

no shutdown ethernet 0
no shutdown ethernet 4
interface ethernet 0 100full
interface ethernet 4 100full
ip address 5.0.0.1 255.0.0.0
failover ip address 5.0.0.5
virtual 13.13.13.13:80:0:tcp is
virtual 13.13.13.13:23:0:tcp is
predictor 13.13.13.13:80:0:tcp roundrobin
predictor 13.13.13.13:23:0:tcp roundrobin

```

```
redirection 13.13.13.13:80:0:tcp dispatched assisted
redirection 13.13.13.13:23:0:tcp dispatched assisted
real 5.100.100.100:80:0:tcp is
real 5.100.100.100:23:0:tcp is
bind 13.13.13.13:80:0:tcp 5.100.100.100:80:0:tcp
bind 13.13.13.13:23:0:tcp 5.100.100.100:23:0:tcp
```

Troubleshooting the ASLB Configuration

Table 45-6 lists the possible problem symptoms and recommended actions to troubleshoot the ASLB configuration.

Table 45-6 Troubleshooting the ASLB Configuration

Symptom	Recommended Action
LocalDirector does not receive any traffic.	Ensure that the LocalDirector is connected to the ports that you specified by entering the set lda server and set lda router commands.
LocalDirector connection entries are not purged.	Ensure that you configured all the virtual-IP/port pairs by entering the set lda vip command.
ASLB MLS entries are created in only one direction.	<p>Ensure that you configured all the virtual-IP/port pairs on both the supervisor engine (set lda vip command) and the LocalDirector.</p> <p>Ensure that the LocalDirector is in the “dispatched assisted” mode.</p> <p>Ensure that you configured the IP addresses of the routers, LocalDirector, and servers following the guidelines in the “IP Addresses” section on page 45-9.</p> <p>Ensure that the router knows how to reach the LocalDirector when traffic goes to the virtual-IP address (if the virtual-IP address is on a different subnet than the router interface).</p> <p>Ensure that the router MAC address is the same as specified by entering the set lda mac router command.</p> <p>Ensure that the LocalDirector MAC address is the same as specified by entering the set lda mac ld command.</p>
Backup LocalDirector does not receive any traffic.	Ensure that you configured the backup LocalDirector ports by entering the set lda router and set lda server commands; for example, enter set lda router {router_vlan} 3/7 3/9 and set lda server {server_vlan} 3/8 3/10 .
You can ping servers from the router, but ASLB MLS entries are not created when you send data traffic.	Ensure that the servers were configured to ignore ARP requests for the virtual-IP address.
You see the message: %CDP-4-NVLANMISMATCH: Native vlan mismatch detected on port ...	Disable CDP ¹ on ports that are connected to the LocalDirector (enter the set cdp disable command).

Table 45-6 *Troubleshooting the ASLB Configuration (continued)*

Symptom	Recommended Action
LocalDirector set commands did not take effect.	<p>The set lda commands will not take effect until you enter the commit lda command.</p> <p>You can verify which set lda commands are in effect by entering the show lda commit command.</p> <p>You can determine which set lda commands are set but not committed or what changes will occur if the current set lda commands are committed by entering the show lda uncommitted command.</p>
You see “collisions” or “port disabled” on the Catalyst 6500 series switch port.	Ensure that the port speed and duplex settings are compatible on both ends of the link between the LocalDirector and the switch. For example, if port 3/7 on the switch is connected to interface ethernet 0 on the LocalDirector, make sure that port 3/7 is set to 100full and that interface ethernet 0 on the LocalDirector is also set to 100full.

1. CDP = Cisco Discovery Protocol