



Configuring Spanning Tree PortFast, UplinkFast, BackboneFast, and Loop Guard

This chapter describes how to configure the spanning tree PortFast, UplinkFast, BackboneFast, and loop guard features on the Catalyst 6000 family switches.



Note

For information on configuring the Spanning Tree Protocol (STP), see [Chapter 8, “Configuring Spanning Tree.”](#)



Note

For complete syntax and usage information for the commands used in this chapter, refer to the *Catalyst 6000 Family Command Reference* publication.

This chapter consists of these sections:

- [Understanding How PortFast Works, page 9-2](#)
- [Understanding How PortFast BPDU Guard Works, page 9-2](#)
- [Understanding How PortFast BPDU Filter Works, page 9-2](#)
- [Understanding How UplinkFast Works, page 9-3](#)
- [Understanding How BackboneFast Works, page 9-4](#)
- [Understanding How Loop Guard Works, page 9-5](#)
- [Configuring PortFast, page 9-7](#)
- [Configuring PortFast BPDU Guard, page 9-9](#)
- [Configuring PortFast BPDU Filter, page 9-11](#)
- [Configuring UplinkFast, page 9-13](#)
- [Configuring BackboneFast, page 9-15](#)
- [Configuring Loop Guard, page 9-17](#)

Understanding How PortFast Works

PortFast causes a spanning tree port to immediately enter the forwarding state, bypassing the listening and learning states. You can use PortFast on switch ports connected to a single workstation or server to allow those devices to connect to the network immediately, rather than waiting for spanning tree to converge.

**Caution**

Use PortFast only when connecting a single end station to a switch port. Otherwise, you might create a network loop.

To prevent loops in a network, you can enable PortFast on nontrunking access ports only because these ports typically do not transmit or receive bridge protocol data units (BPDUs). If you enable PortFast on nontrunking ports that connect two switches, spanning tree loops can occur if BPDUs are being transmitted and received on those ports. The most secure implementation of PortFast occurs when you enable it on ports that connect end stations to switches.

Understanding How PortFast BPDU Guard Works

PortFast BPDU guard prevents spanning tree loops by moving a nontrunking port into the errdisable state when a BPDU is received on that port. When you enable BPDU guard on the switch, spanning tree shuts down PortFast-configured interfaces that receive BPDUs, rather than putting them into the spanning tree blocking state. In a valid configuration, PortFast-configured interfaces do not receive BPDUs. In an invalid configuration, a BPDU is received by a PortFast-configured interface, such as a connection of an unauthorized device. BPDU guard can prevent invalid configurations, because you must manually put the interface back in service.

**Note**

When enabled on the switch, spanning tree applies the PortFast BPDU guard feature to all PortFast-configured interfaces.

Understanding How PortFast BPDU Filter Works

BPDU filtering allows you to avoid transmitting BPDUs on a PortFast-enabled port connected to an end system. This feature is available on a per-port basis.

The PortFast BPDU filter allows access ports to move directly to the forwarding state as soon as end hosts are connected. Spanning tree sends BPDUs from all ports regardless of whether PortFast is enabled or not. A port does not need to be PortFast enabled to actively filter BPDUs.

BPDU filtering operates in both the transmit and receive directions; BPDUs are dropped when received and they are not transmitted.

Understanding How UplinkFast Works

UplinkFast provides fast convergence after a spanning tree topology change and achieves load balancing between redundant links using uplink groups. An uplink group is a set of ports (per VLAN), only one of which is forwarding at any given time. Specifically, an uplink group consists of the root port (which is forwarding) and a set of blocked ports. The blocked ports do not include self-looping ports. The uplink group provides an alternate path in case the currently forwarding link fails.



Note

UplinkFast is most useful in wiring-closet switches. This feature may not be useful for other types of applications.

Figure 9-1 shows an example topology with no link failures. Switch A, the root switch, is connected directly to Switch B over link L1 and to Switch C over link L2. The port on Switch C that is connected directly to Switch B is in blocking state.

Figure 9-1 UplinkFast Example Before Direct Link Failure

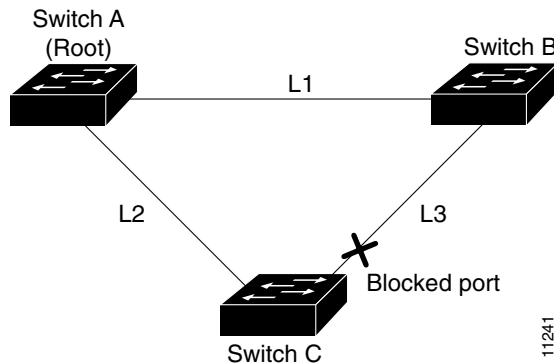

If Switch C detects a link failure on the currently active link L2 (a direct link failure), UplinkFast unblocks the blocked port on Switch C and transitions it to the forwarding state without going through the listening and learning states, as shown in Figure 9-2. This switchover takes approximately 1 to 5 seconds.

Figure 9-2 UplinkFast Example After Direct Link Failure

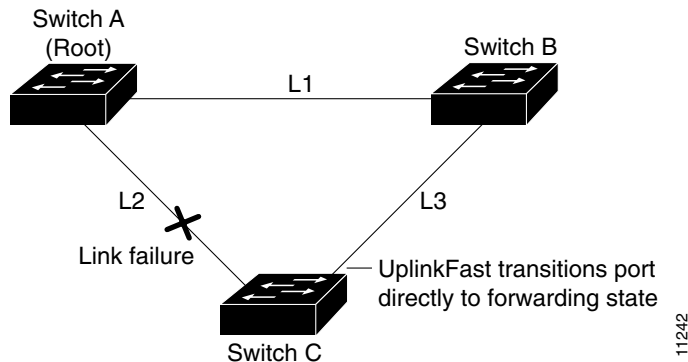

Understanding How BackboneFast Works

BackboneFast is initiated when a root port or blocked port on a switch receives inferior BPDUs from its designated bridge. An inferior BPDU identifies one switch as both the root bridge and the designated bridge. When a switch receives an inferior BPDU, it indicates that a link to which the switch is not directly connected (an indirect link) has failed (that is, the designated bridge has lost its connection to the root bridge). Under normal spanning tree rules, the switch ignores inferior BPDUs for the configured maximum aging time, as specified by the *agingtime* variable of the **set spantree maxage** command.

The switch tries to determine if it has an alternate path to the root bridge. If the inferior BPDU arrives on a blocked port, the root port and other blocked ports on the switch become alternate paths to the root bridge. (Self-looped ports are not considered alternate paths to the root bridge.) If the inferior BPDU arrives on the root port, all blocked ports become alternate paths to the root bridge. If the inferior BPDU arrives on the root port and there are no blocked ports, the switch assumes that it has lost connectivity to the root bridge, causes the maximum aging time on the root to expire, and becomes the root switch according to normal spanning tree rules.

If the switch has alternate paths to the root bridge, it uses these alternate paths to transmit a new kind of PDU called the Root Link Query PDU out all alternate paths to the root bridge. If the switch determines that it still has an alternate path to the root, it causes the maximum aging time on the ports on which it received the inferior BPDU to expire. If all the alternate paths to the root bridge indicate that the switch has lost connectivity to the root bridge, the switch causes the maximum aging times on the ports on which it received an inferior BPDU to expire. If one or more alternate paths can still connect to the root bridge, the switch makes all ports on which it received an inferior BPDU its designated ports and moves them out of the blocking state (if they were in the blocking state), through the listening and learning states, and into the forwarding state.

Figure 9-3 shows an example topology with no link failures. Switch A, the root switch, connects directly to Switch B over link L1 and to Switch C over link L2. The port on Switch C that connects directly to Switch B is in the blocking state.

Figure 9-3 BackboneFast Example Before Indirect Link Failure

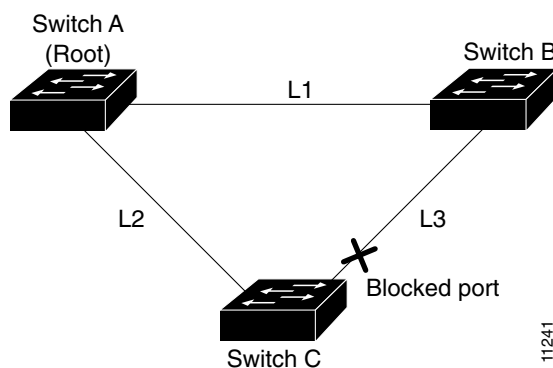

If link L1 fails, Switch C detects this failure as an indirect failure, since it is not connected directly to link L1. Switch B no longer has a path to the root switch. BackboneFast allows the blocked port on Switch C to move immediately to the listening state without waiting for the maximum aging time for the port to expire. BackboneFast then transitions the port on Switch C to the forwarding state, providing a path from Switch B to Switch A. This switchover takes approximately 30 seconds. Figure 9-4 shows how BackboneFast reconfigures the topology to account for the failure of link L1.

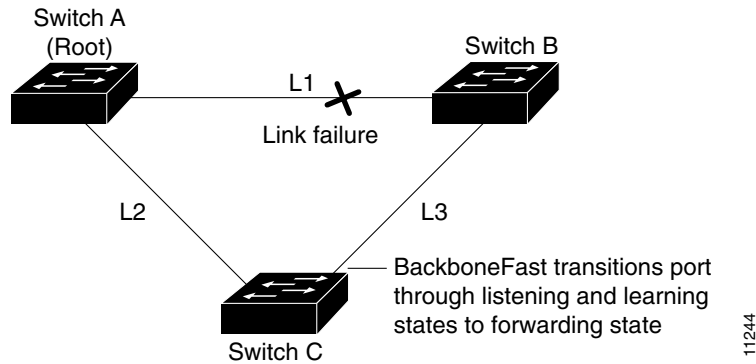
Figure 9-4 BackboneFast Example After Indirect Link Failure

If a new switch is introduced into a shared-medium topology, BackboneFast is not activated. [Figure 9-5](#) shows a shared-medium topology in which a new switch is added. The new switch begins sending inferior BPDUs that say it is the root switch. However, the other switches ignore these inferior BPDUs and the new switch learns that Switch B is the designated bridge to Switch A, the root switch.

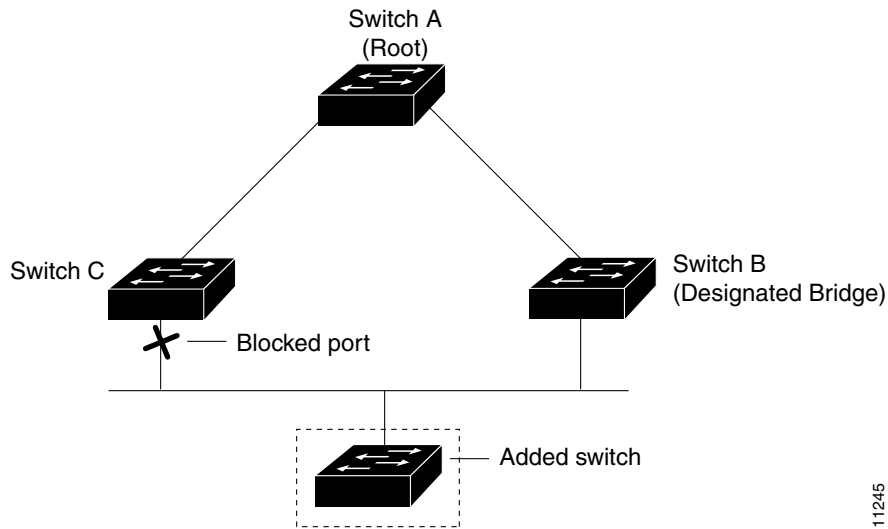
Figure 9-5 Adding a Switch in a Shared-Medium Topology

Understanding How Loop Guard Works

Unidirectional link failures may cause a root port or alternate port to become designated as root if BPDUs are absent. Some software failures may introduce temporary loops in the network. The loop guard feature checks if a root port or an alternate root port receives BPDUs. If the port is not receiving BPDUs, the loop guard feature puts the port into an inconsistent state until it starts receiving BPDUs again. Loop guard isolates the failure and lets spanning tree converge to a stable topology without the failed link or bridge.

You can enable loop guard on a per-port basis. When you enable loop guard, it is automatically applied to all of the active instances or VLANs to which that port belongs. When you disable loop guard, it is disabled for the specified ports. Disabling loop guard moves all loop-inconsistent ports to the listening state.

If you enable loop guard on a channel and the first link becomes unidirectional, loop guard blocks the entire channel until the affected port is removed from the channel. [Figure 9-6](#) shows loop guard in a triangle switch configuration.

Figure 9-6 Triangle Switch Configuration with Loop Guard

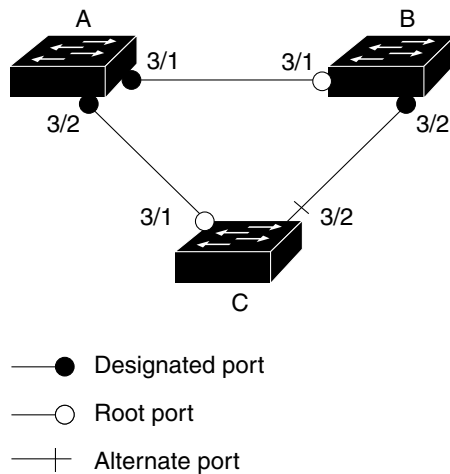

[Figure 9-6](#) illustrates the following configuration:

- Switches A and B are distribution switches.
- Switch C is an access switch.
- Loop guard is enabled on ports 3/1 and 3/2 on Switches A, B, and C.

Use loop guard only in topologies where there are blocked ports. Topologies that have no blocked ports, which are loop free, do not need to enable this feature. Enabling loop guard on a root switch has no effect but provides protection when a root switch becomes a nonroot switch.

Follow these guidelines when using loop guard:

- You cannot enable loop guard on PortFast-enabled or dynamic VLAN ports.
- You cannot enable PortFast on loop guard-enabled ports.
- You cannot enable loop guard if root guard is enabled.

Loop guard interacts with other features as follows:

- Loop guard does not affect the functionality of UplinkFast or BackboneFast.
- Do not enable loop guard on ports that are connected to a shared link.



Note We recommend that you enable loop guard on root ports and alternate root ports on access switches.

- Root guard forces a port to be always designated as the root port. Loop guard is effective only if the port is a root port or an alternate port. You cannot enable loop guard and root guard on a port at the same time.
- PortFast transitions a port into a forwarding state immediately when a link is established. Because a PortFast-enabled port will not be a root port or alternate port, loop guard and PortFast cannot be configured on the same port. Assigning dynamic VLAN membership for the port requires that the port is PortFast enabled. You cannot configure a loop guard-enabled port with dynamic VLAN membership.
- If your network has a type-inconsistent port or a PVID-inconsistent port, all BPDUs are dropped until the misconfiguration is corrected. The port transitions out of the inconsistent state after the message age expires. Loop guard ignores the message age expiration on type-inconsistent ports and PVID-inconsistent ports. If the port is already blocked by loop guard, misconfigured BPDUs received on the port make loop guard recover, but the port is moved into the type-inconsistent state or PVID-inconsistent state.
- In high-availability switch configurations, if a port is put into the blocked state by loop guard, it remains blocked even after switchover to the redundant supervisor engine. The newly activated supervisor engine recovers the port only after receiving a BPDU on that port.
- Loop guard uses the ports known to spanning tree. Loop guard can take advantage of logical ports provided by the Port Aggregation Protocol (PAgP). However, to form a channel, all the physical ports grouped in the channel must have compatible configurations. PAgP enforces uniform configurations of root guard or loop guard on all the physical ports to form a channel.

These caveats apply to loop guard:

- Spanning tree always chooses the first operational port in the channel to send the BPDUs. If that link becomes unidirectional, loop guard blocks the channel, even if other links in the channel are functioning properly.
- If a set of ports that are already blocked by loop guard are grouped together to form a channel, spanning tree loses all the state information for those ports and the new channel port may obtain the forwarding state with a designated role.
- If a channel is blocked by loop guard and the channel breaks, spanning tree loses all the state information. The individual physical ports may obtain the forwarding state with the designated role, even if one or more of the links that formed the channel are unidirectional.

**Note**

You can enable UniDirectional Link Detection (UDLD) to help isolate the link failure. A loop may occur until UDLD detects the failure, but loop guard will not be able to detect it.

- Loop guard has no effect on a disabled spanning tree instance or a VLAN.

Configuring PortFast

These sections describe how to configure PortFast on the switch:

- [Enabling PortFast, page 9-8](#)
- [Disabling PortFast, page 9-8](#)

Enabling PortFast



Caution

Use PortFast only when you connect a single end station to a switch port; otherwise, you might create a network loop.

To enable PortFast on a switch port, perform this task in privileged mode:

	Task	Command
Step 1	Enable PortFast on a switch port connected to a single workstation or server.	set spantree portfast <i>mod/port</i> enable
Step 2	Verify the PortFast setting.	show spantree <i>mod/port</i>

This example shows how to enable PortFast on a port and verify the configuration (the PortFast status is shown in the “Fast-Start” column):

```
Console> (enable) set spantree portfast 4/1 enable
Warning: Spantree port fast start should only be enabled on ports connected
to a single host. Connecting hubs, concentrators, switches, bridges, etc. to
a fast start port can cause temporary spanning tree loops. Use with caution.
Spantree port 4/1 fast start enabled.
```

```
Console> (enable) show spantree 4/1
Port      Vlan  Port-State  Cost  Priority  Fast-Start  Group-method
-----
4/1       1     blocking    19    20       enabled
4/1       100   forwarding  10    20       enabled
4/1       521   blocking    19    20       enabled
4/1       522   blocking    19    20       enabled
4/1       523   blocking    19    20       enabled
4/1       524   blocking    19    20       enabled
4/1       1003  not-connected 19    20       enabled
4/1       1005  not-connected 19    4        enabled
Console> (enable)
```

Disabling PortFast

To disable PortFast on a switch port, perform this task in privileged mode:

	Task	Command
Step 1	Disable PortFast on a switch port.	set spantree portfast <i>mod/port</i> disable
Step 2	Verify the PortFast setting.	show spantree <i>mod/port</i>

This example shows how to disable PortFast on a port:

```
Console> (enable) set spantree portfast 4/1 disable
Spantree port 4/1 fast start disabled.
Console> (enable)
```

Configuring PortFast BPDU Guard

These sections describe how to configure PortFast BPDU guard on the switch:

- [Enabling PortFast BPDU Guard, page 9-9](#)
- [Disabling PortFast BPDU Guard, page 9-10](#)

Enabling PortFast BPDU Guard



Note

Although the PortFast feature is configured on an individual port, the PortFast BPDU guard option is configured globally. When you disable PortFast on a port, PortFast BPDU guard becomes inactive.

To enable PortFast BPDU guard on a nontrunking switch port, perform this task in privileged mode:

	Task	Command
Step 1	Enable PortFast BPDU guard on the switch.	set spantree portfast bpdu-guard enable
Step 2	Verify the PortFast BPDU guard setting.	show spantree summary

This example shows how to enable PortFast BPDU guard on the switch and verify the configuration in the Per VLAN Spanning Tree + (PVST+) mode:



Note

For additional PVST+ information, see [Chapter 8, “Configuring Spanning Tree.”](#)

```
Console> (enable) set spantree portfast bpdu-guard enable
Spantree portfast bpdu-guard enabled on this switch.
Console> (enable) show spantree summary
Root switch for vlans: none.
Portfast bpdu-guard enabled for bridge.
Uplinkfast disabled for bridge.
Backbonefast disabled for bridge.
```

```
Vlan  Blocking  Listening  Learning  Forwarding  STP Active
-----  -
      1         0         0         0           4           4
      2         0         0         0           4           4
      3         0         0         0           4           4
      4         0         0         0           4           4
      5         0         0         0           4           4
      6         0         0         0           4           4
     10         0         0         0           4           4
     20         0         0         0           4           4
     50         0         0         0           4           4
    100         0         0         0           4           4
    152         0         0         0           4           4
    200         0         0         0           5           5
    300         0         0         0           4           4
    400         0         0         0           4           4
    500         0         0         0           4           4
    521         0         0         0           4           4
    524         0         0         0           4           4
    570         0         0         0           4           4
    801         0         0         0           0           0
```

```

802      0      0      0      0      0
850      0      0      0      4      4
917      0      0      0      4      4
999      0      0      0      4      4
1003     0      0      0      0      0
1005     0      0      0      0      0

      Blocking Listening Learning Forwarding STP Active
-----
Total      0      0      0      85      85
Console> (enable)

```

Disabling PortFast BPDU Guard

To disable PortFast BPDU guard on the switch, perform this task in privileged mode:

	Task	Command
Step 1	Disable PortFast BPDU guard on the switch.	set spantree portfast bpdu-guard disable
Step 2	Verify the PortFast BPDU guard setting.	show spantree

This example shows how to disable PortFast BPDU guard on the switch and verify the configuration:

```

Console> (enable) set spantree portfast bpdu-guard disable
Spantree portfast bpdu-guard disabled on this switch.
Console> (enable) show spantree summary
Summary of connected spanning tree ports by vlan

```

```

Portfast bpdu-guard disabled for bridge.
Uplinkfast disabled for bridge.
Backbonefast disabled for bridge.

```

```

Vlan  Blocking Listening Learning Forwarding STP Active
-----
1      0      0      0      4      4
2      0      0      0      4      4
3      0      0      0      4      4
4      0      0      0      4      4
5      0      0      0      4      4
6      0      0      0      4      4
10     0      0      0      4      4
20     0      0      0      4      4
50     0      0      0      4      4
100    0      0      0      4      4
152    0      0      0      4      4
200    0      0      0      5      5
300    0      0      0      4      4
400    0      0      0      4      4
500    0      0      0      4      4
521    0      0      0      4      4
524    0      0      0      4      4
570    0      0      0      4      4
801    0      0      0      0      0
802    0      0      0      0      0
850    0      0      0      4      4
917    0      0      0      4      4
999    0      0      0      4      4

```

```

1003          0          0          0          0          0
1005          0          0          0          0          0

          Blocking Listening Learning Forwarding STP Active
-----
Total          0          0          0          85          85
Console> (enable)

```

Configuring PortFast BPDU Filter

These sections describe how to configure PortFast BPDU filter on the switch:

- [Enabling PortFast BPDU Filter, page 9-11](#)
- [Disabling PortFast BPDU Filter, page 9-12](#)

Enabling PortFast BPDU Filter

To enable PortFast BPDU filtering on a nontrunking port, perform this task in privileged mode:

	Task	Command
Step 1	Enable PortFast BPDU filtering on the port.	set spantree portfast bpdu-filter enable
Step 2	Verify the PortFast BPDU filter setting.	show spantree summary show spantree portfast

This example shows how to enable PortFast BPDU filtering on the port and verify the configuration in PVST+ mode:



Note For PVST+ information, see [Chapter 8, “Configuring Spanning Tree.”](#)

```

Console> (enable) set spantree portfast bpdu-filter enable
Usage: set spantree portfast <mod/port> <enable|disable>
       set spantree portfast bpdu-guard <enable|disable>
       set spantree portfast bpdu-filter <enable|disable>
Spantree portfast bpdu-filter enabled on this switch.

```

```

Console> (enable) show spantree portfast
Portfast BPDU guard is disabled.
Portfast BPDU filter is disabled.

```

```

Console> (enable) show spantree summary
Root switch for vlans: none.
Portfast bpdu-filter enabled for bridge.
Uplinkfast disabled for bridge.
Backbonefast disabled for bridge.

```

```

Vlan  Blocking  Listening  Learning  Forwarding  STP Active
-----
    1         0         0         0           4           4
    2         0         0         0           4           4
    3         0         0         0           4           4
    4         0         0         0           4           4
    5         0         0         0           4           4
    6         0         0         0           4           4
    .
    .
    .
   850         0         0         0           4           4
   917         0         0         0           4           4
   999         0         0         0           4           4
  1003         0         0         0           0           0
  1005         0         0         0           0           0

          Blocking  Listening  Learning  Forwarding  STP Active
          -----
Total          0         0         0           85          85
Console> (enable)

```

Disabling PortFast BPDU Filter

To disable PortFast BPDU filtering on the switch, perform this task in privileged mode:

	Task	Command
Step 1	Disable PortFast BPDU filtering on the switch.	set spantree portfast bpdu-filter disable
Step 2	Verify the PortFast BPDU filter setting.	show spantree show portfast

This example shows how to disable PortFast BPDU filtering on the switch and verify the configuration:

```

Console> (enable) set spantree portfast bpdu-filter disable
Spantree portfast bpdu-filter disabled on this switch.
Console> (enable) show spantree summary
Summary of connected spanning tree ports by vlan

Portfast bpdu-filter disabled for bridge.
Uplinkfast disabled for bridge.
Backbonefast disabled for bridge.

```

```

Vlan  Blocking  Listening  Learning  Forwarding  STP Active
-----
    1         0         0         0           4           4
    2         0         0         0           4           4
    3         0         0         0           4           4
    4         0         0         0           4           4
    5         0         0         0           4           4
    6         0         0         0           4           4
   10         0         0         0           4           4
    .
    .
    .
   802         0         0         0           0           0
   850         0         0         0           4           4
   917         0         0         0           4           4
   999         0         0         0           4           4

```

```

1003      0      0      0      0      0
1005      0      0      0      0      0

      Blocking Listening Learning Forwarding STP Active
-----
Total      0      0      0      85      85
Console> (enable)

```

Configuring UplinkFast

You can configure UplinkFast for PVST+ or for Multi-Instance Spanning Tree Protocol (MISTP). The command is the same but the output may be slightly different.



Note

For additional MISTP information, see [Chapter 8, “Configuring Spanning Tree.”](#)

These sections describe how to configure UplinkFast on the switch:

- [Enabling UplinkFast, page 9-13](#)
- [Disabling UplinkFast, page 9-14](#)

Enabling UplinkFast

The **set spantree uplinkfast enable** command increases the path cost of all ports on the switch, making it unlikely that the switch will become the root switch. The *station_update_rate* value represents the number of multicast packets transmitted per 100 milliseconds (the default is 15 packets per millisecond).



Note

When you enable the **set spantree uplinkfast** command, it affects all VLANs on the switch. You cannot configure UplinkFast on an individual VLAN.

To enable UplinkFast on the switch, perform this task in privileged mode:

	Task	Command
Step 1	Enable UplinkFast on the switch.	set spantree uplinkfast enable [<i>rate station_update_rate</i>] [all-protocols off on]
Step 2	Verify that UplinkFast is enabled.	show spantree uplinkfast [{ mistp-instance <i>instances</i> }] <i>vlan</i> s]

With PVST+ mode enabled, this example shows how to enable UplinkFast with a station-update rate of 40 packets per 100 milliseconds and how to verify that UplinkFast is enabled:

```

Console> (enable) set spantree uplinkfast enable
VLANs 1-4094 bridge priority set to 49152.
The port cost and portvlancost of all ports set to above 3000.
Station update rate set to 15 packets/100ms.
uplinkfast all-protocols field set to off.
uplinkfast enabled for bridge.

```

```

Console> (enable) show spantree uplinkfast 1 100 521-524
Station update rate set to 15 packets/100ms.
uplinkfast all-protocols field set to off.
VLAN          port list
-----
1             1/1(fwd),1/2
100          1/2(fwd)
521          1/1(fwd),1/2
522          1/1(fwd),1/2
523          1/1(fwd),1/2
524          1/1(fwd),1/2
Console> (enable)

```

This example shows how to display the UplinkFast feature settings for all VLANs:

```

Console> show spantree uplinkfast
Station update rate set to 15 packets/100ms.
uplinkfast all-protocols field set to off.
VLAN port list
-----
1-20  1/1(fwd),1/2-1/5
21-50 1/9(fwd), 1/6-1/8, 1/10-1/12
51-100 2/1(fwd), 2/12
Console>

```

With MISTP mode enabled, this example shows the output when you enable UplinkFast:

```

Console> (enable) set spantree uplinkfast enable
Instances 1-16 bridge priority set to 49152.
The port cost and portinstancecost of all ports set to above 10000000.
Station update rate set to 15 packets/100ms.
uplinkfast all-protocols field set to off.
uplinkfast enabled for bridge.
Console> (enable)

```

This example shows how to display the UplinkFast feature settings for a specific instance:

```

Console> show spantree uplinkfast mistp-instance 1
Station update rate set to 15 packets/100ms.
uplinkfast all-protocols field set to off.
Inst  port list
-----
1      4/1(fwd)
Console>

```

Disabling UplinkFast

The **set spantree uplinkfast disable** command disables UplinkFast on the switch, but the switch priority and port cost values are not reset to the factory defaults.



Note

When you enter the **set spantree uplinkfast disable** command, it affects all VLANs on the switch. You cannot disable UplinkFast on an individual VLAN.

To disable UplinkFast on the switch, perform this task in privileged mode:

	Task	Command
Step 1	Disable UplinkFast on the switch.	set spantree uplinkfast disable
Step 2	Verify that UplinkFast is disabled.	show spantree uplinkfast

With PVST+ mode enabled, this example shows how to disable UplinkFast on the switch and verify the configuration:

```

Console> (enable) set spantree uplinkfast disable
Uplinkfast disabled for switch.
Use clear spantree uplinkfast to return stp parameters to default.
Console> (enable) show spantree uplinkfast
Station update rate set to 15 packets/100ms.
uplinkfast all-protocols field set to off.
VLAN          port list
-----
1              1/1 (fwd) ,1/2
100           1/2 (fwd)
521           1/1 (fwd) ,1/2
522           1/1 (fwd) ,1/2
523           1/1 (fwd) ,1/2
524           1/1 (fwd) ,1/2
Console> (enable)

```

Configuring BackboneFast

These sections describe how to configure BackboneFast:

- [Enabling BackboneFast, page 9-15](#)
- [Displaying BackboneFast Statistics, page 9-16](#)
- [Disabling BackboneFast, page 9-16](#)

Enabling BackboneFast



Note

For BackboneFast to work, you must enable it on all switches in the network. BackboneFast is not supported on Token Ring VLANs. This feature is supported for use with third-party switches.

To enable BackboneFast on the switch, perform this task in privileged mode:

	Task	Command
Step 1	Enable BackboneFast on the switch.	set spantree backbonefast enable
Step 2	Verify that BackboneFast is enabled.	show spantree backbonefast

This example shows how to enable BackboneFast on the switch and how to verify the configuration:

```
Console> (enable) set spantree backbonefast enable
Backbonefast enabled for all VLANs
Console> (enable) show spantree backbonefast
Backbonefast is enabled.
Console> (enable)
```

Displaying BackboneFast Statistics

To display BackboneFast statistics, perform this task in privileged mode:

Task	Command
Display BackboneFast statistics.	show spantree summary

This example shows how to display BackboneFast statistics:

```
Console> (enable) show spantree summary
Summary of connected spanning tree ports by vlan

Uplinkfast disabled for bridge.
Backbonefast enabled for bridge.

Vlan  Blocking  Listening  Learning  Forwarding  STP Active
-----
   1      0         0         0           1           1

          Blocking  Listening  Learning  Forwarding  STP Active
          -----
Total      0         0         0           1           1

BackboneFast statistics
-----
Number of inferior BPDUs received (all VLANs) : 0
Number of RLQ req PDUs received (all VLANs)  : 0
Number of RLQ res PDUs received (all VLANs)   : 0
Number of RLQ req PDUs transmitted (all VLANs): 0
Number of RLQ res PDUs transmitted (all VLANs): 0
Console> (enable)
```

Disabling BackboneFast

To disable BackboneFast on the switch, perform this task in privileged mode:

	Task	Command
Step 1	Disable BackboneFast on the switch.	set spantree backbonefast disable
Step 2	Verify that BackboneFast is disabled.	show spantree backbonefast

This example shows how to disable BackboneFast on the switch and how to verify the configuration:

```
Console> (enable) set spantree backbonefast disable
Backbonefast enabled for all VLANs
Console> (enable) show spantree backbonefast
Backbonefast is disable.
Console> (enable)
```

Configuring Loop Guard

These sections describe how to configure BackboneFast:

- [Enabling Loop Guard, page 9-17](#)
- [Disabling Loop Guard, page 9-17](#)

Enabling Loop Guard

Use the **set spantree guard** command to enable or disable the spanning tree loop guard feature on a per-port basis.

To enable loop guard on the switch, perform this task in privileged mode:

	Task	Command
Step 1	Enable loop guard on a port.	set spantree guard loop <i>mod/port</i>
Step 2	Verify that loop guard is enabled.	show spantree guard { <i>mod/port</i> <i>vlan</i> } mistp-instance <i>instance</i>

This example shows how to enable loop guard:

```
Console> (enable) set spantree guard loop 5/1
Rootguard is enabled on port 5/1, enabling loopguard will disable rootguard on
this port.
Do you want to continue (y/n) [n]? y
Loopguard on port 5/1 is enabled.
Console> (enable)
```

Disabling Loop Guard

To disable loop guard on the switch, perform this task in privileged mode:

	Task	Command
Step 1	Disable loop guard on a port.	set spantree guard none <i>mod/port</i>
Step 2	Verify that loop guard is disabled.	show spantree guard { <i>mod/port</i> <i>vlan</i> } mistp-instance <i>instance</i>

This example shows how to disable loop guard:

```
Console> (enable) set spantree guard none 5/1
Rootguard is disabled on port 5/1, disabling loopguard will disable rootguard on
this port.
Do you want to continue (y/n) [n]? y
Loopguard on port 5/1 is disabled.
Console> (enable)
```

